

General Disclaimer

One or more of the Following Statements may affect this Document

- This document has been reproduced from the best copy furnished by the organizational source. It is being released in the interest of making available as much information as possible.
- This document may contain data, which exceeds the sheet parameters. It was furnished in this condition by the organizational source and is the best copy available.
- This document may contain tone-on-tone or color graphs, charts and/or pictures, which have been reproduced in black and white.
- This document is paginated as submitted by the original source.
- Portions of this document are not fully legible due to the historical nature of some of the material. However, it is the best reproduction available from the original submission.

NASA TECHNICAL MEMORANDUM

NASA TM-82513

EDDY CURRENT X-Y SCANNER SYSTEM

By George W. Kurtz
Materials and Processes Laboratory



February 1983

(NASA-TM-82513) EDDY CURRENT X-Y SCANNER
SYSTEM (NASA) 48 p HC A03/HP A01 CSCL 14B

N83-22571

Unclas
63/35 03275

NASA

*George C. Marshall Space Flight Center
Marshall Space Flight Center, Alabama*

1. REPORT NO. NASA TM-82513		2. GOVERNMENT ACCESSION NO.		3. RECIPIENT'S CATALOG NO.	
4. TITLE AND SUBTITLE Eddy Current X-Y Scanner System				5. REPORT DATE February 1983	
				6. PERFORMING ORGANIZATION CODE	
7. AUTHOR(S) George W. Kurtz				8. PERFORMING ORGANIZATION REPORT #	
9. PERFORMING ORGANIZATION NAME AND ADDRESS George C. Marshall Space Flight Center Marshall Space Flight Center, Alabama 35812				10. WORK UNIT NO.	
				11. CONTRACT OR GRANT NO.	
				12. TYPE OF REPORT & PERIOD COVERED Technical Memorandum	
12. SPONSORING AGENCY NAME AND ADDRESS National Aeronautics and Space Administration Washington, D.C. 20546				14. SPONSORING AGENCY CODE	
15. SUPPLEMENTARY NOTES Prepared by Materials and Processes Laboratory, Science and Engineering.					
16. ABSTRACT <p>The Nondestructive Evaluation Branch of the Materials and Processes Laboratory became aware of a need for a miniature, portable X-Y scanner capable of performing eddy current or other non-destructive testing scanning operations such as ultrasonic, or small areas of flat plate. This report covers the technical description and operational theory of the X-Y scanner system designed and built to fulfill this need. The scanner has been given limited testing and performs according to its design intent, which is to scan flat plate areas of approximately 412 cm² (64 in.²) during each complete cycle of scanning.</p> <p style="text-align: center;">ORIGINAL PAGE IS OF POOR QUALITY</p>					
17. KEY WORDS Nondestructive Evaluation Nondestructive Testing Scanners			18. DISTRIBUTION STATEMENT Unclassified - Unlimited		
19. SECURITY CLASSIF. (of this report) Unclassified		20. SECURITY CLASSIF. (of this page) Unclassified		21. NO. OF PAGES 45	22. PRICE NTIS

TABLE OF CONTENTS

	Page
I. INTRODUCTION	1
II. DESCRIPTION AND THEORY OF OPERATION	1
A. Description	1
III. OPERATING INSTRUCTIONS	3
A. Operation for Horizontal Plate Testing	3
B. Operation for Inclined Plate Testing	4

PRECEDING PAGE BLANK NOT FILMED

LIST OF ILLUSTRATIONS

Figure	Title	Page
1.	X-Y scanner.....	5
2.	X-Y scanner.....	6
3.	Main slide support.....	7
4.	Main slide support modification.....	8
5.	Slide support.....	9
6.	Slide support modification.....	10
7.	Saddle.....	11
8.	Support shaft.....	12
9.	Corner block.....	13
10.	Ratchet.....	14
11.	Retainer.....	15
12.	Spring, ratchet.....	16
13.	BRG. pin.....	17
14.	Angle, side.....	18
15.	Corner block.....	19
16.	Angle, rear.....	20
17.	Scan shaft.....	21
18.	Scan pin.....	22
19.	Gear, index.....	23
20.	Angle, front.....	24
21.	Sleeve.....	25

LIST OF ILLUSTRATIONS (Concluded)

Figure	Title	Page
22.	Positioner	26
23.	Shim	27
24.	Spring	28
25.	Spacer	29
26.	Bracket	30
27.	Bracket	31
28.	Plate	32
29.	Shim	33
30.	Rack	34
31.	Pawl	35
32.	Stanchion	36
33.	Spacer	37
34.	Stiffener	38
35.	X-Y scanner assembly (Sheet 1)	39
36.	X-Y scanner assembly (Sheet 2)	40

TECHNICAL MEMORANDUM

EDDY CURRENT X-Y SCANNER SYSTEM

I. INTRODUCTION

The Materials and Processes Laboratory at the Marshall Space Flight Center (MSFC) developed a need for an additional test device to aid in the nondestructive testing of flat plate type structures. This need arose after manual testing of a section of SRB flight hardware proved difficult and time consuming. To fulfill this need the Nondestructive Evaluation Branch within this Laboratory designed and had built a small portable X-Y scanner capable of testing flat plate, primarily utilizing eddy current test probes but adaptable to other type test probes such as ultrasonic. This report presents the technical description and operational details of the scanner.

II. DESCRIPTION AND THEORY OF OPERATION

A. Description

1. General. The X-Y scanner system was developed to enable use of standard eddy current probe-coil detection units of shaft diameters ranging from 1.27 cm (0.5 in.) to 1.91 cm (0.75 in.) for detection of surface or near-surface defects in flat plate. However, any other probe or test device such as ultrasonic, within the diameters given above, could also be employed, if an X-Y scan over a flat surface is desired.

Design of the scanner was based on the concept of a light weight assembly, having great portability, ease of operation, and employing as simple a drive mechanism as could be conceived, for purposes of low cost, ease of fabrication and maintenance, and durability. To achieve the light weight, most of the structure was made of aircraft grade aluminum, with some use of standard angle sections for the frame. A parallelogram-type slide structure was chosen for the slides, using precision ground steel shafting. All sliding parts contained prelubricated sleeve bearings for compactness, low friction, and ease of maintenance.

The system (Fig. 1 and 2) measures 35.56 cm (14 in.) by 38.74 cm (15.25 in.) length by width, and weighs 3.17 kg (7 lb) in its operating condition and 7.93 kg (17.5 lb) with its storage container. The assembly is completely portable and is easily handled by one person. It employs a miniature 12 V motor to drive a continuous or closed loop helix shaft, which in turn guides a follower attached to the eddy current detector support saddle over an "X" scan path. As the follower reaches the end of the Helix travel and is reversed in direction, the ratchet strikes a cam gear mounted on a shaft carrying a gear engaged to a rod used to index the saddle in the "Y" direction. In this manner of movement, "X" scan is accomplished over a travel of 20.32 cm (8 in.) in approximately 3 sec, while a "Y" index of approximately 1.58 mm (0.0625 in.) is accomplished every two scans in the "X" direction. Travel in the "Y" direction is approximately 20.32 cm (8 in.). Combined X-Y scanning enables a coverage of 412 cm² (64 in.²). Once a scan is completed, the cam gear must be disengaged at the end of the "Y" travel, and the saddle and its support mechanism returned to the start position of "Y" index. A plate area of 412 cm² (64 in.²) can be scanned in less than 2 min.

2. Function of Major Components. The functions of the major components are as follows:

a) 12 Vdc Motor – This is geared down from its 450 rpm rotation by a 10:1 ratio gear box to drive the eddy current probe support saddle over an "X" direction travel at a velocity of approximately 7.62 cm (3 in.)/sec.

b) Saddle – This component provides the support for the eddy current probes and enables their traverse in the "X" direction. A second purpose is to contain the ratchet that strikes the index cam gear, creating the "Y" direction index. Thirdly, it houses the scan pin which engages the helix machined shaft geared to the dc motor. Lastly, this component supports and positions the potentiometer which is used to record the "X" position of the saddle and eddy current probe.

c) Helix Shaft – This shaft has a continuous helix groove machined in it to a pitch of 2.86 cm (1.125 in.) so that full spirals are created with a closed loop radius at both ends. As this shaft is continuously rotated at 45 rpm by the dc motor it forces the saddle to traverse back and forth in the "X" direction through engagement of the scan pin housed in the saddle body.

d) Main Slide Support – A housing which slides in the "Y" direction, supporting the tubes which guide the saddle and containing the cam gear, rack mating gear, pawl, and related parts comprising the "Y" direction index mechanism. In addition, it is the housing for one end of the helix shaft.

e) Slide Support – At the opposite end of the saddle support tubes from the main slide support, this item also houses the saddle support tubes, and slides over the large "Y" direction support tubes, maintaining the parallelogram of the X-Y scanner design. The potentiometer for recording the "Y" position is supported by this component.

f) Ratchet – This is the part that causes the "Y" direction index by striking the cam gear at the end of the travel of the saddle. It rotates the cam gear a fraction of a complete revolution, leading to an index of approximately 1.58 mm (0.0625 in.) every reciprocation of the saddle. The ratchet is repositioned to its striking position by a flat spring. Shims are used to set the contact area between cam gear and ratchet.

g) Pawl – This small part engages the cam gear and prevents back-lash when "Y" index occurs. It is held in contact with the cam gear by a miniature coil spring.

h) Cam Gear – A specially designed and machined gear that receives the force of the ratchet when contacted, causing it to rotate, and in turn rotating a gear meshed with a rack, on the same shaft. The turning action of the rack gear against the rack causes the main slide support and slide support assembly to index in the "Y" direction.

3. Operating Range, Mechanical. This scanner is designed for operation over flat plate and will scan an area of approximately 412 cm² (64 in.²), equal to 20.32 cm (8 in.) in both X and Y travel, each complete cycle of operation. With limitations, it will operate over plate inclined from the horizontal, even to the 90 deg position. This will be limited by weight and configuration of the eddy current probes and attached wiring. Coverage of a 412 cm² (64 in.²) area can be accomplished in approximately 2 min.

4. Operating Parameters, Eddy Current. The saddle, in which the eddy current probe is retained, can readily accommodate probes measuring 1.27 cm (0.5 in.) to 1.91 cm (0.75 in.) diameter. Small probes also can be accommodated if additional spacers are provided. Typical eddy current instrumentation having a light weight, highly flexible probe cable should be employed.

5. Power Requirements. The drive motor operates at 12 Vdc, drawing no load current of 100 mA and full-load current of 500 mA. The 12 V power must be supplied by a separate power supply. Two standard 1.5 V "D" size batteries, mounted on the scanner frame, supply voltage outputs via two position-indicator potentiometers, allowing scan position display on a separate oscilloscope.

6. System Drawings. A complete set of mechanical drawings is enclosed herein. These are reflected by dwg numbers EH13-16 through -23 and EH13-26 through -48.

III. OPERATING INSTRUCTIONS

ORIGINAL PAGE IS
OF POOR QUALITY

A. Operation for Horizontal Plate Testing

For horizontal plate testing, the operator should proceed as follows:

- 1) Remove the scanner from its carrying case and place it over the flat plate area to be scanned.
- 2) Check the plate area for obstructions to scan travel, assuring their absence.
- 3) Check the general levelness of the scanner, in relation to the plate surface being scanned, adjusting the four stem glides as necessary to assure level, stable positioning.
- 4) Install the eddy current probe in the saddle and adjust probe to desired height (lift-off) above plate.
- 5) Assure ON/OFF switch is in OFF position, and connect external 12 Vdc power supply. Adjust to 12 V, if necessary.
- 6) Conduct normal hookup and adjustment of eddy current testing instrumentation.
- 7) Slide the saddle and main slide support assembly to the extreme "Y" index position opposite the battery side of the frame. Disengagement of the brass index pawl from the index gear will be necessary to enable this movement; hold the pawl away from the cam gear as the assembly is moved to its start position.
- 8) Position the saddle to the mid-scan position on its support shafts, by manually turning either the Helix shaft or the gear coupling the scan shaft to the dc motor.
- 9) Assure the Helix shaft grove and both pairs of support tubes are liberally lubricated. Apply a light machine oil or grease, if necessary.
- 10) Place the ON/OFF switch in ON position and observe scanning motions.
- 11) Continuously monitor scanning and indexing motions for occurrence of mechanism binding. **WARNING** - Excessive binding can cause overloading of the motor and result in motor damage!
- 12) If excessive binding occurs, immediately place ON/OFF switch in OFF position and check for foreign material or insufficient lubricant on the slide mechanisms, scanner/probe to plate interference, or other cause. To restart scanning, repeat step 8) above, and remove the cause of binding before placing the ON/OFF switch back in the ON position.

13) When the end of "Y" travel is reached, the limit switch should shut-off the scanner, however, monitor the operation so as not to allow the scanner to drive to the extreme "Y" position where jamming with the frame may occur. Place the ON/OFF switch in the OFF position once the limit of "Y" travel is reached. Repositioning the scanner to the desired start position per step 8 can then be accomplished and scanning started by placing ON/OFF switch to "ON" position.

B. Operation for Inclined Plate Testing

For inclined plate testing, the operator should proceed as follows:

- 1) Provide means for fixed positioning of the scanner over the plate area to be tested.
- 2) Assure that the scanner is oriented such that the "Y" axis travel (index) is in the up direction and the "X" axis (saddle) travel is approximately horizontal.
- 3) Check the parallelism of the scanner relative to the plate to be scanned.
- 4) Follow steps 4) through 13) listed previously.

**ORIGINAL PAGE IS
OF POOR QUALITY**

ORIGINAL PAGE IS
OF POOR QUALITY

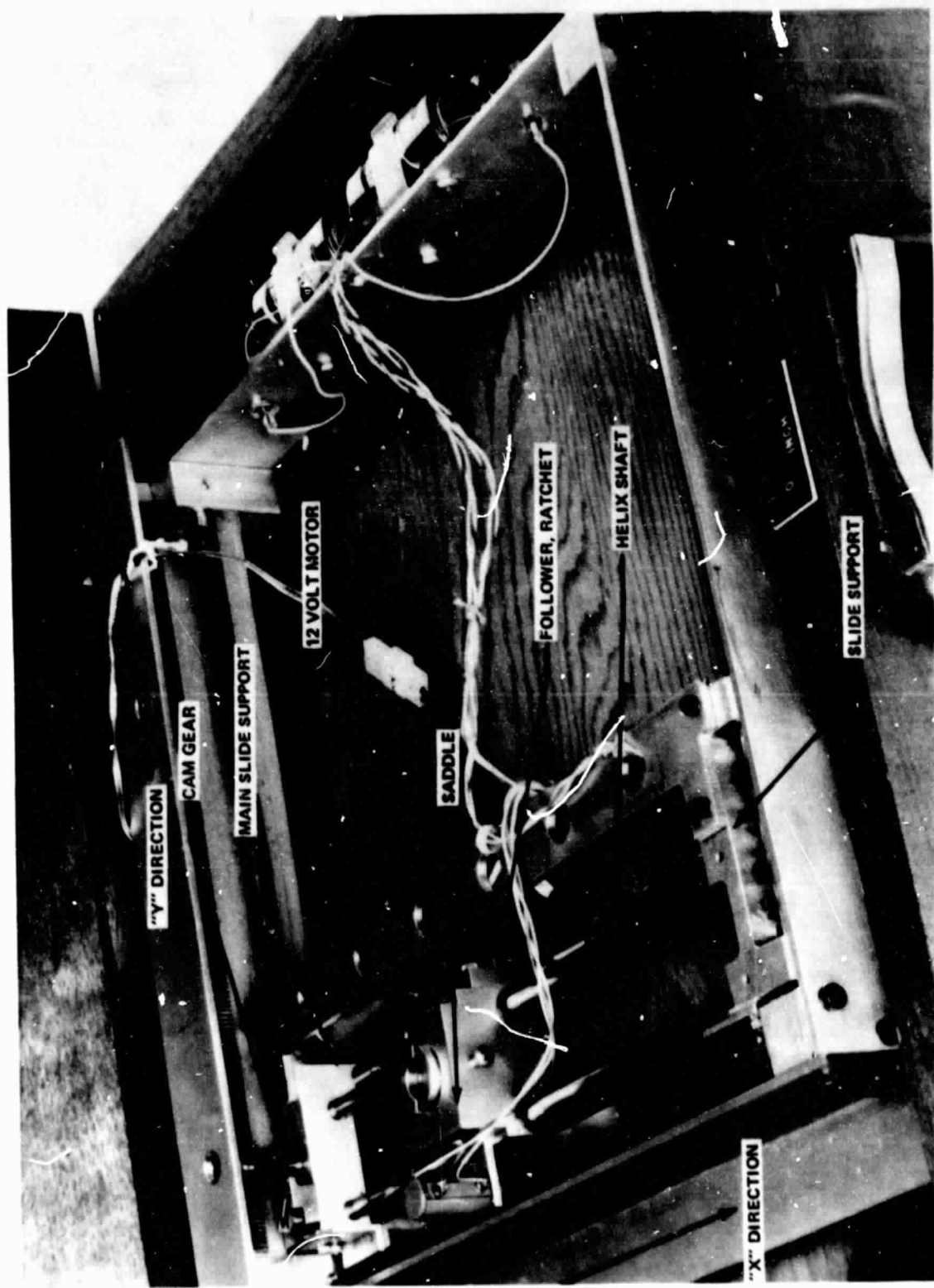

Figure 1. X-Y scanner.

ORIGINAL PAGE IS
OF POOR QUALITY.

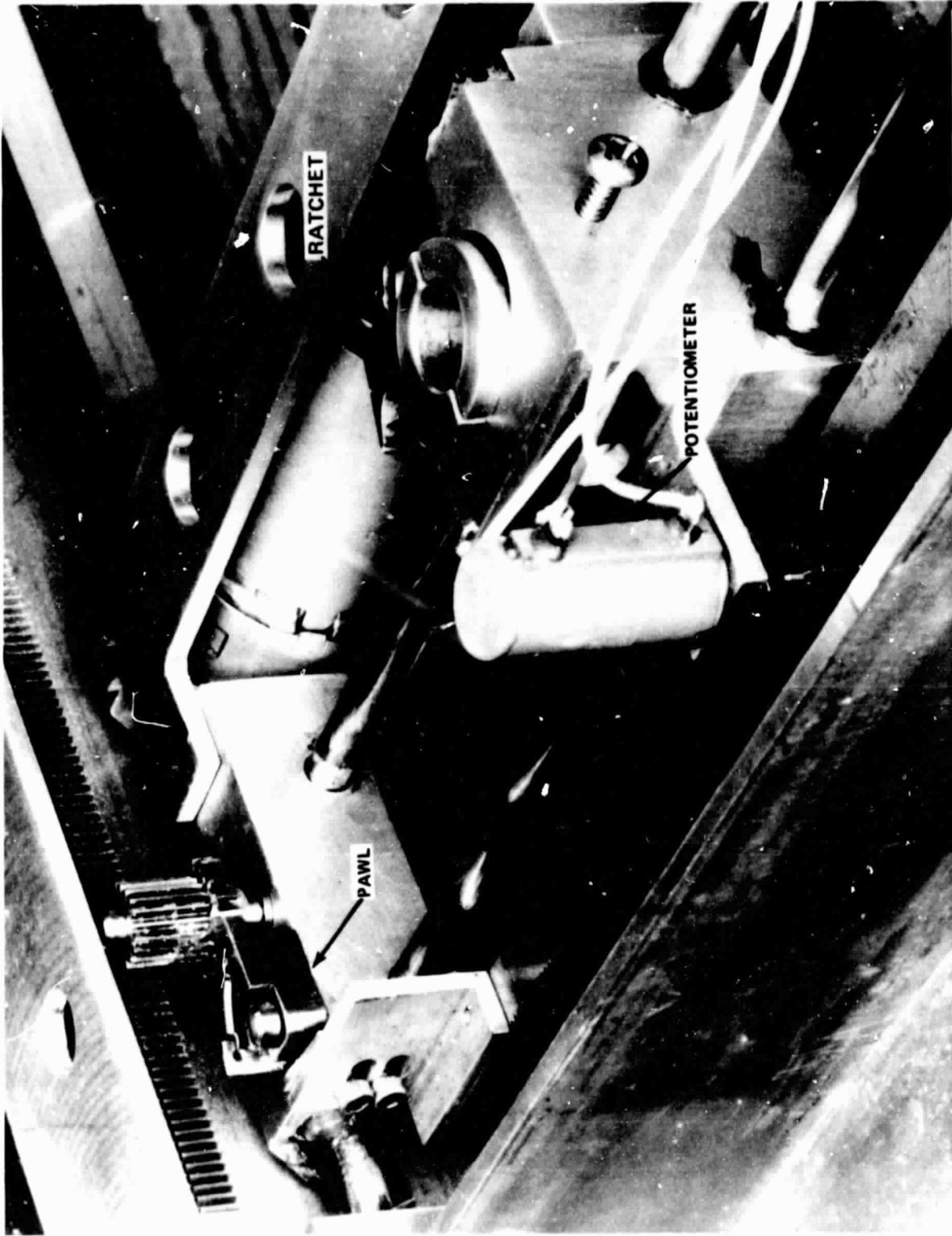
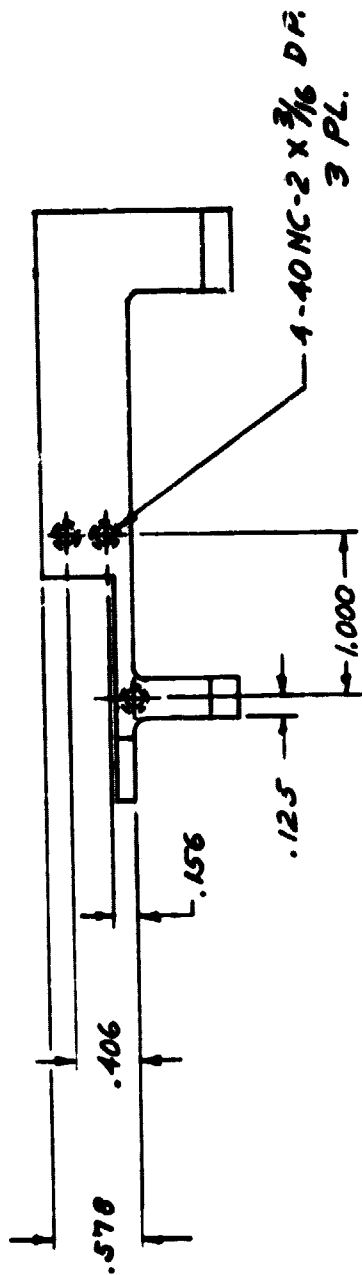
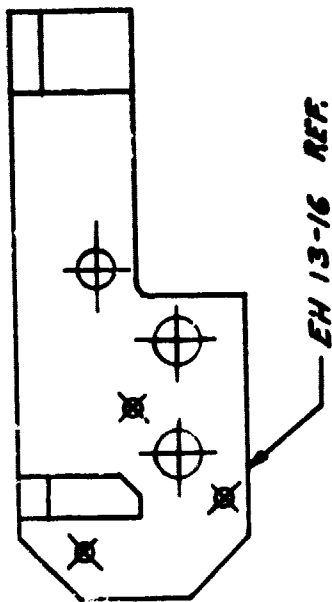

Figure 2. X-Y scanner.



ORIGINAL PAGE IS
OF POOR QUALITY



SCALE: FULL
TOL: $\pm \frac{1}{64}$, $\pm .010$

EH 13-16 -1

GME - 10/31/80

Figure 4. Main slide support modification.

4-40 NC-2 x 3/16 DP, 3 PL.

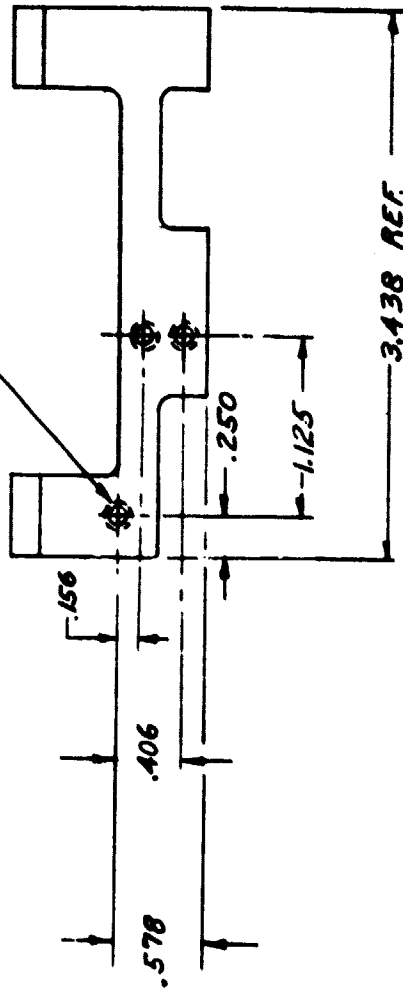

ORIGINAL PAGE IS OF POOR QUALITY

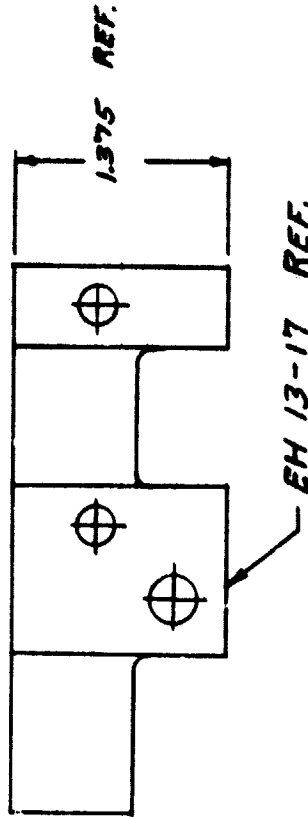

SCALE : FULL
TOL. : ± .010 , ± 1/64

GMX - 10/31/80

EH 13-17 -1

Figure 6. Slide support modification.

ORIGINAL PAGE IS
OF POOR QUALITY

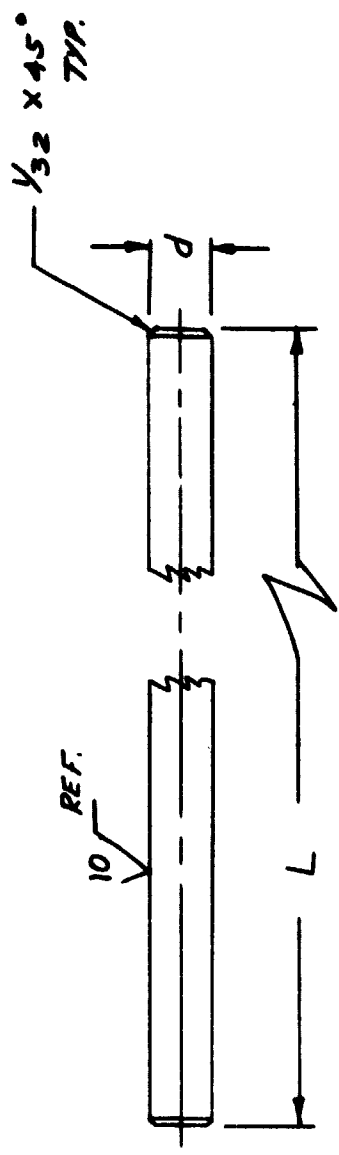

PART	QTY	d	L	VENDOR P/N
-1	2	.3747 ^{+0.0000} _{-.0002}	12 19/32	* A7-140
-2	2	.2497 ^{+0.0000} _{-.0002}	10 7/8	A3-108

* CLOSEST LENGTH TO DMS REQUIREMENT
FINISH MACHINE AS REQUIRED.

SCALE: NONE
MATERIAL: 303 SS, PRECISION GROUND SHAFING
TOL. ± 1/64
VENDOR = PIC CORP.

FINISH: 32√, UNLESS SPECIFIED.

EN13-19

GWK - 9/25/80

Figure 8. Support shaft.

ORIGINAL PAGE
OF POOR QUALITY

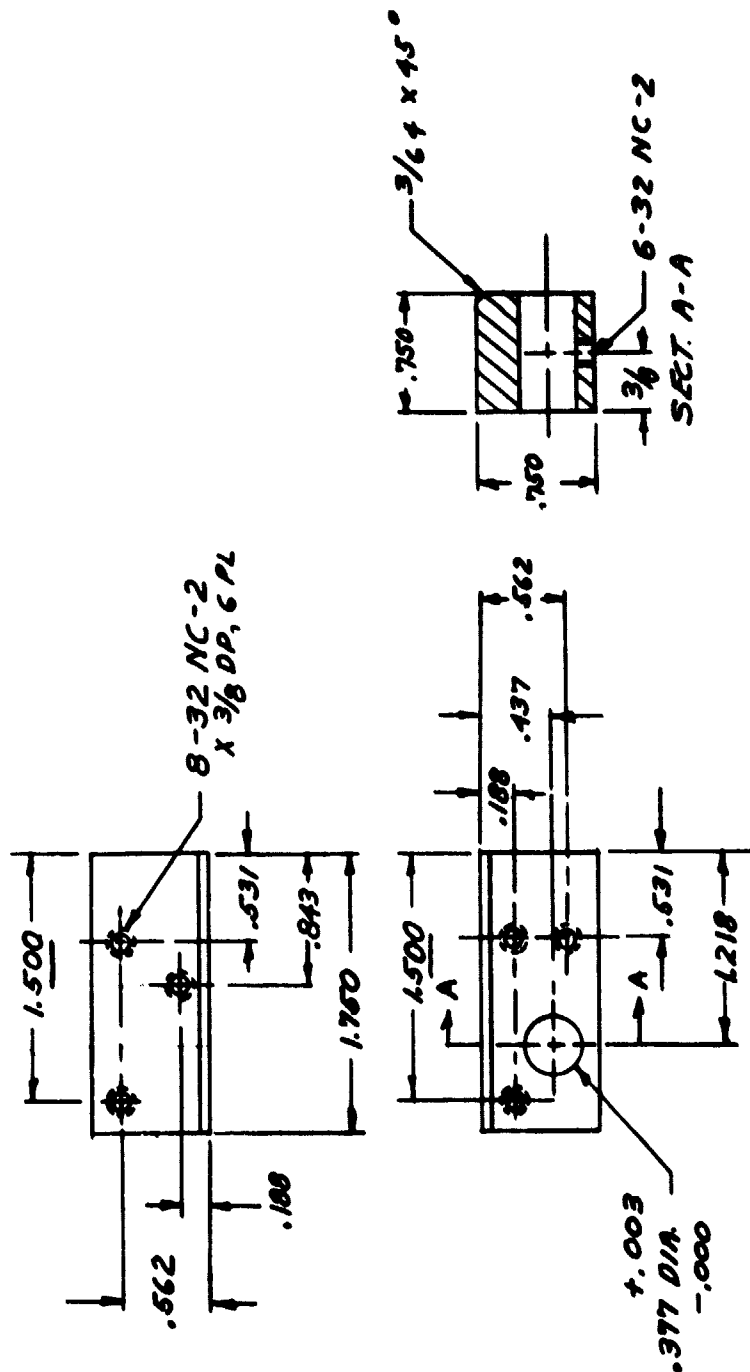

SCALE: FULL
 MATERIAL: 6061 T6 AL.
 TOL.: ± 1/64, ± .010, ± 1/2°
 FINISH: 125

EN 13-20

CVK - 5/20/79

Figure 9. Corner block.

ORIGINAL PAGE IS
OF POOR QUALITY

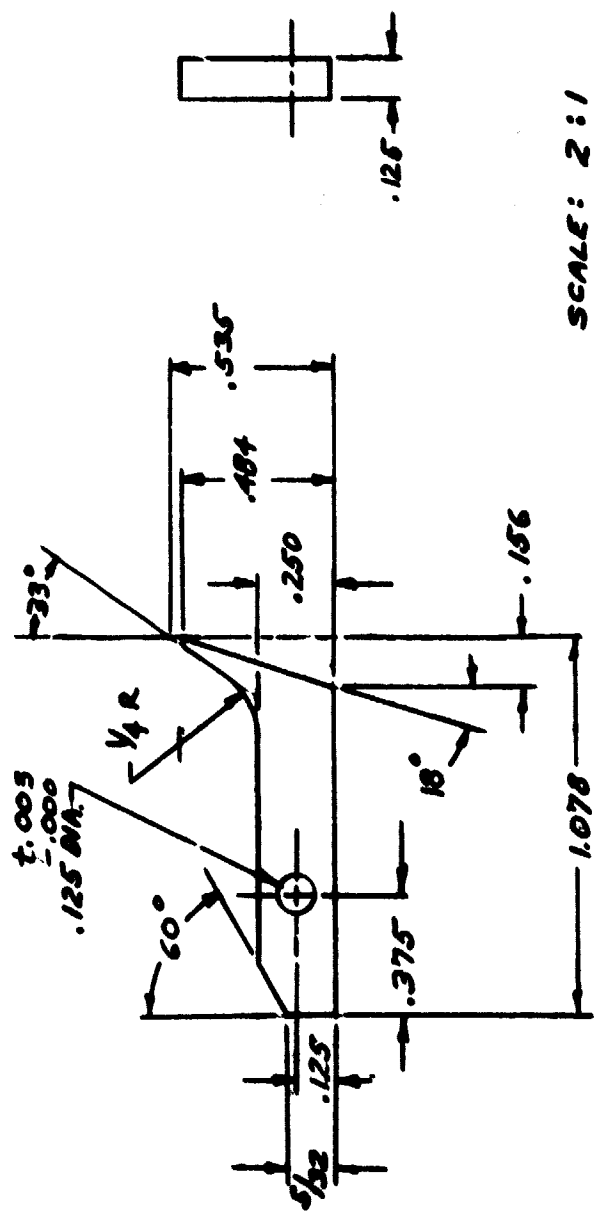

SCALE: 2:1
 MATERIAL: 4130 STL.
 TOL.: 1/64, ±.010, ± 1/2°
 FINISH: 63

NOTE: BORE SNAP EDGES
 MAX 1/64 R.

602-5/20/77

FN 13-21

Figure 10. Ratchet.

ORIGINAL PAGE IS
OF POOR QUALITY

EN 13-22

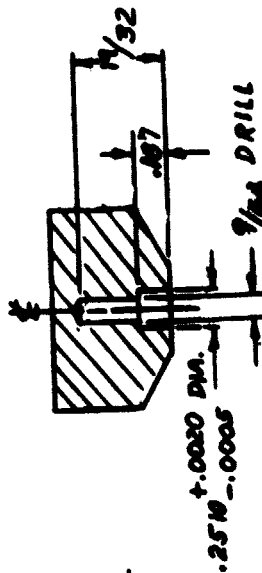
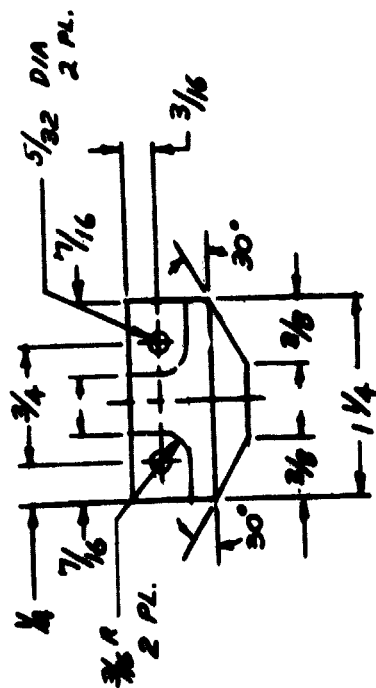
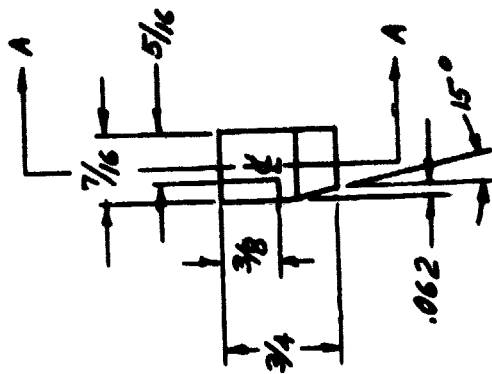

SECT. A-A

SCALE: FULL
 MATERIAL: 6061 T6 AL
 TOL: $\pm 1/64$, $\pm .010$, $\pm 1/2^\circ$
 FINISH: 63

GWX-5/31/77

Figure 11. Retainer.

ORIGINAL PAGE IS
OF POOR QUALITY

FN13-23

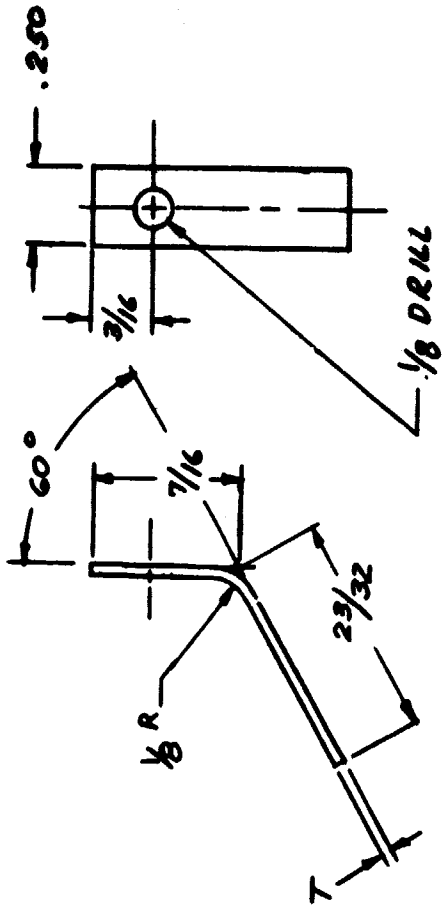

SCALE: 2 : 1
 MATERIAL: FLAT SPRING STEEL, SAE-1050, TEMPERED
 TOL: ± 1/64
 FINISH: 63

PART	T ±.001
1	.012
2	.015
3	.018

602-5/31/77

Figure 12. Spring, ratchet.

ORIGINAL PAGE IS
OF POOR QUALITY

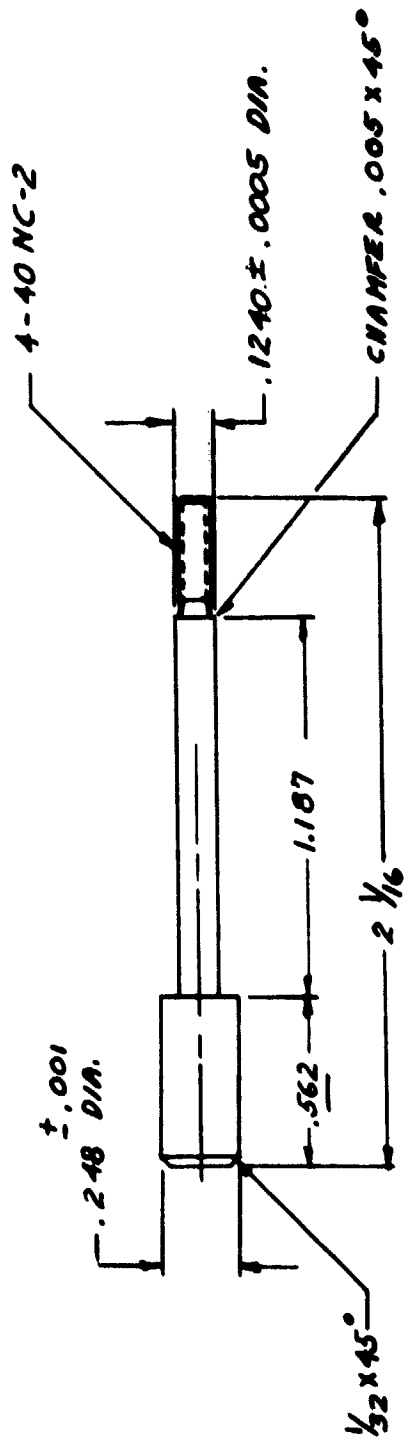

SCALE: 2:1
MATERIAL: 303 SS
TOL: $\pm \frac{1}{64}$, $\pm .010$, $\pm \frac{1}{2}^\circ$
FINISH: $32\sqrt{\quad}$

EN13-26

GWL - 6/31/77

Figure 13. BRG. pin.

ORIGINAL PAGE IS
OF POOR QUALITY

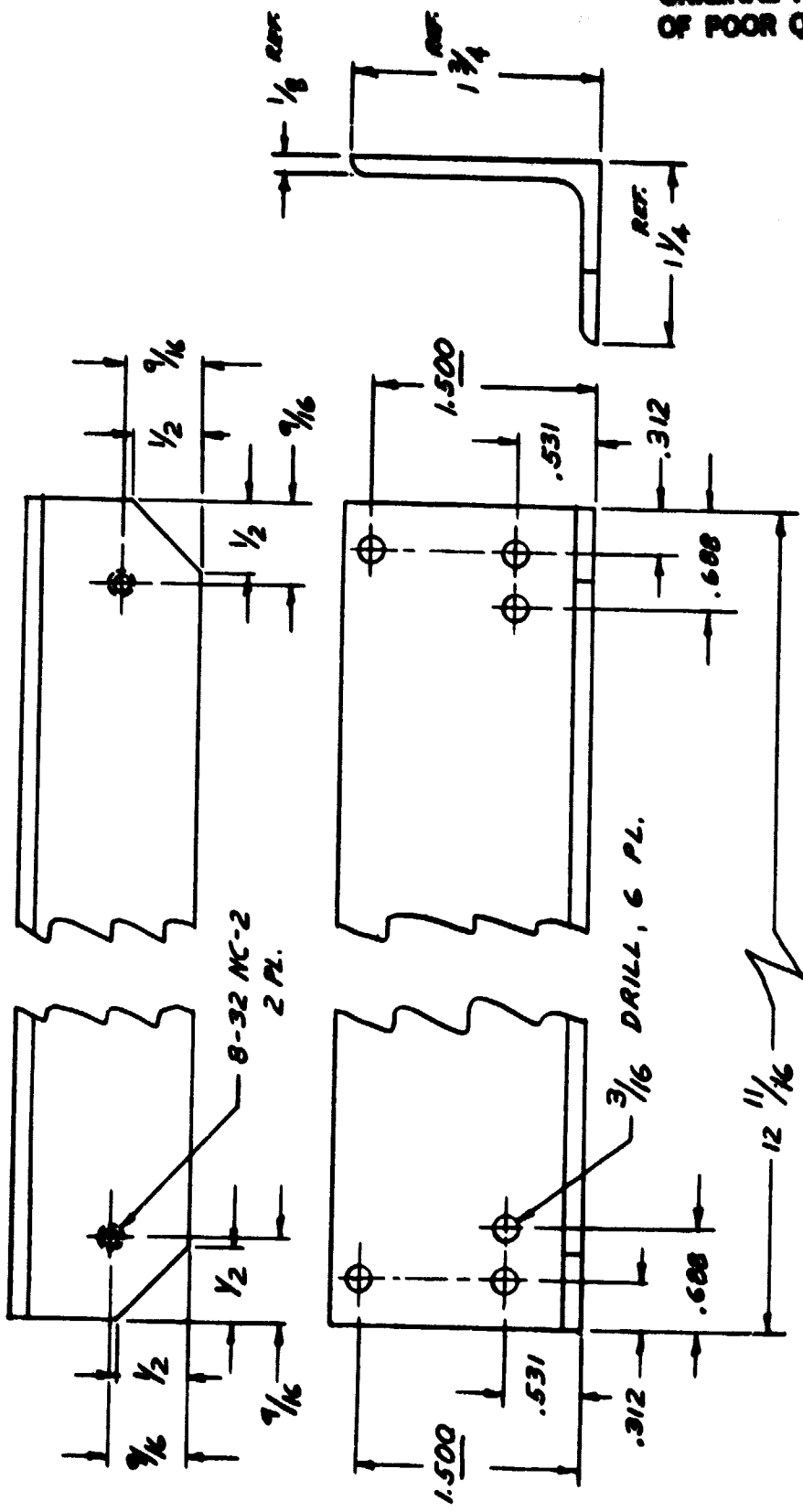

SCALE: FULL
 MATERIAL: 6061 TC AL. ANGLE, $1 \frac{3}{4} \times 1 \frac{1}{4} \times \frac{1}{8}$
 TOL: $\pm \frac{1}{64}$, $\pm .010$, $\pm \frac{1}{2}^\circ$
 FINISH: 125

EH13-27

6WE-6/1/79

Figure 14. Angle, side.

ORIGINAL PAGE IS
OF POOR QUALITY

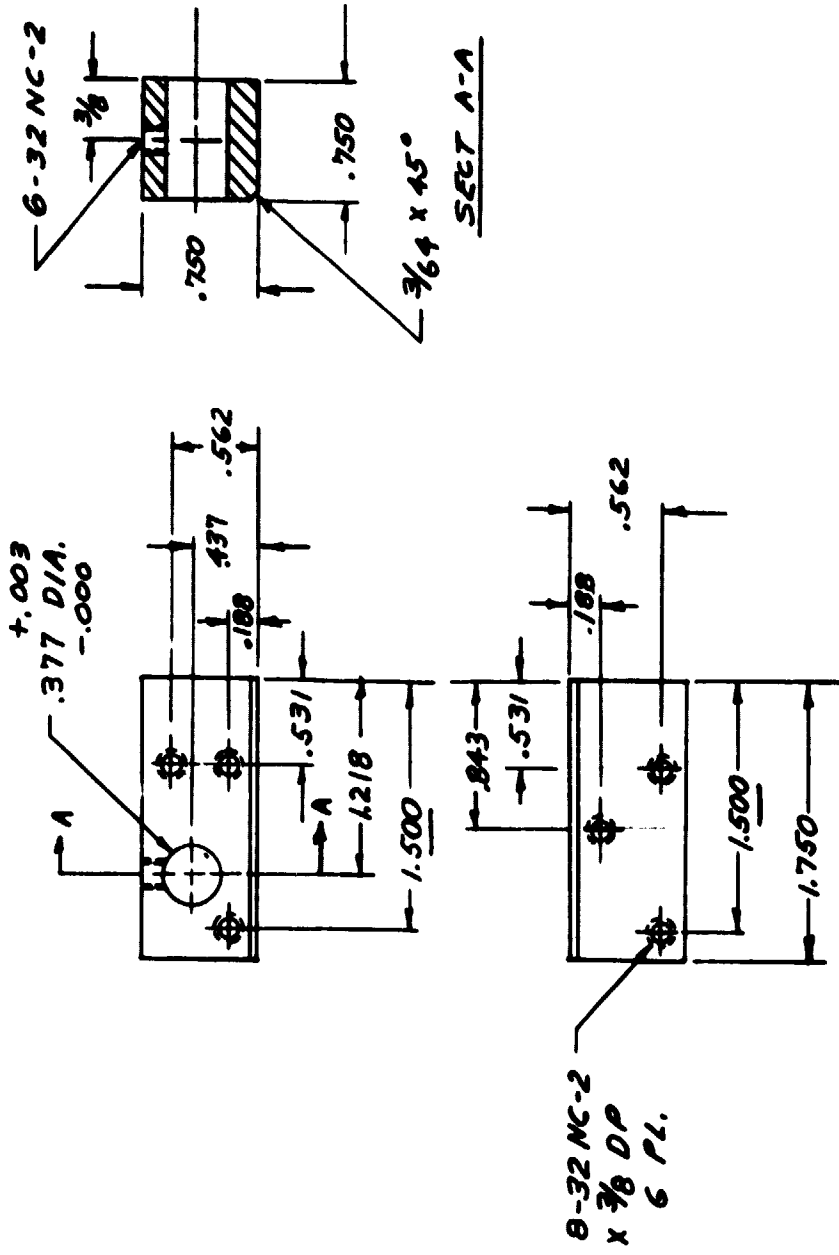

SCALE: FULL
MATERIAL: 6061 T6 AL
TOL: $\pm 1/64$, ± 0.010 , $\pm 1/2^\circ$
FINISH: 125 ✓

EN13-28

GWK-6/1/79

Figure 15. Corner block.

ORIGINAL PAGE IS
OF POOR QUALITY

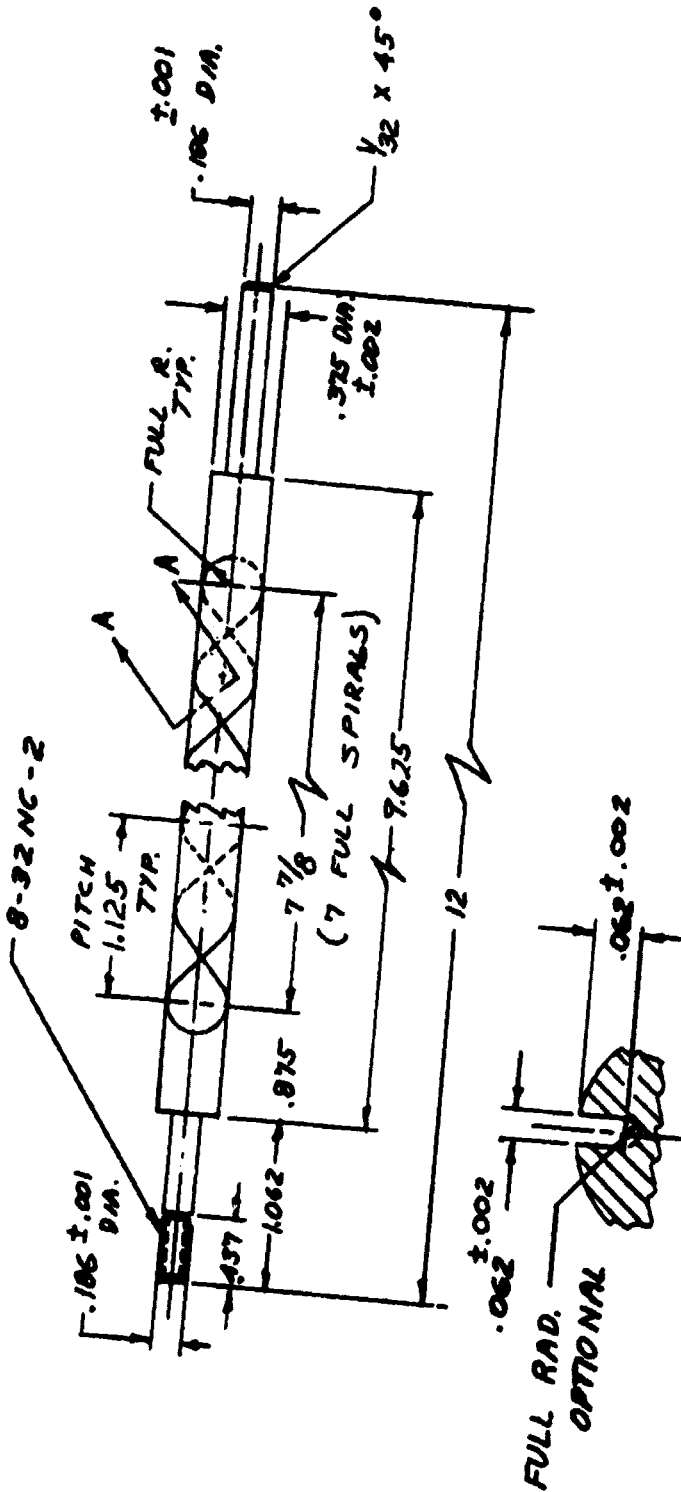

SCALE: FULL
MATERIAL: 4130 ST
TOL: $\pm \frac{1}{64}$, $\pm .010$, $\pm \frac{1}{2}^\circ$
FINISH: $63\sqrt{\text{ }}$

FN13-30

SECT. A-A
SCALE: 4:1

GWK - 6/4/79

Figure 17. Scan shaft.

ORIGINAL PAGE IS
OF POOR QUALITY

EN13-31

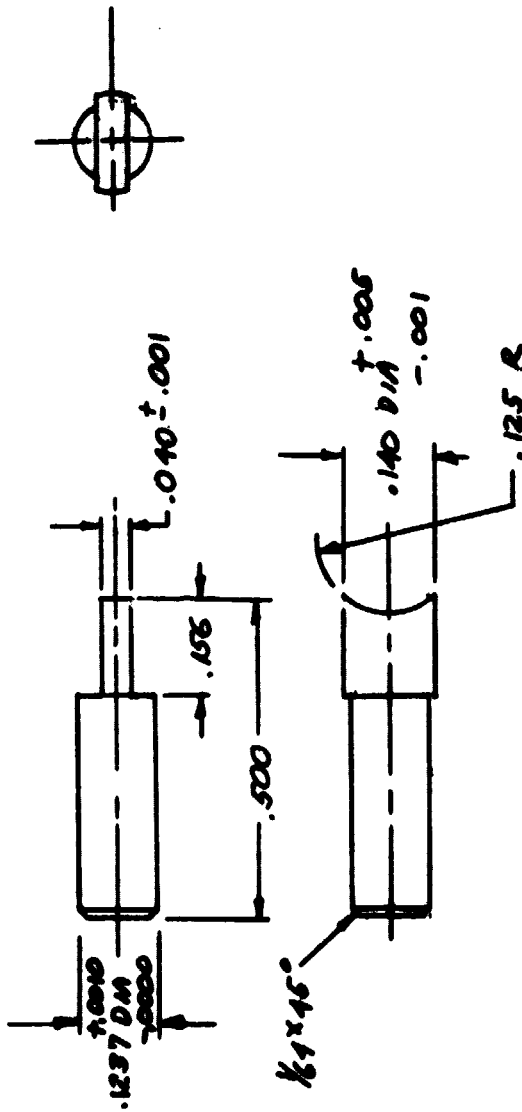

SCALE: 1:1
MATERIAL: 4130 STL.
TOL: $\pm \frac{1}{64}$, $\pm .010$, $\pm \frac{1}{2}$
FINISH: $32\sqrt{\text{---}}$

002-6/6/77

Figure 18. Screw pin.

ORIGINAL PAGE IS
OF POOR QUALITY

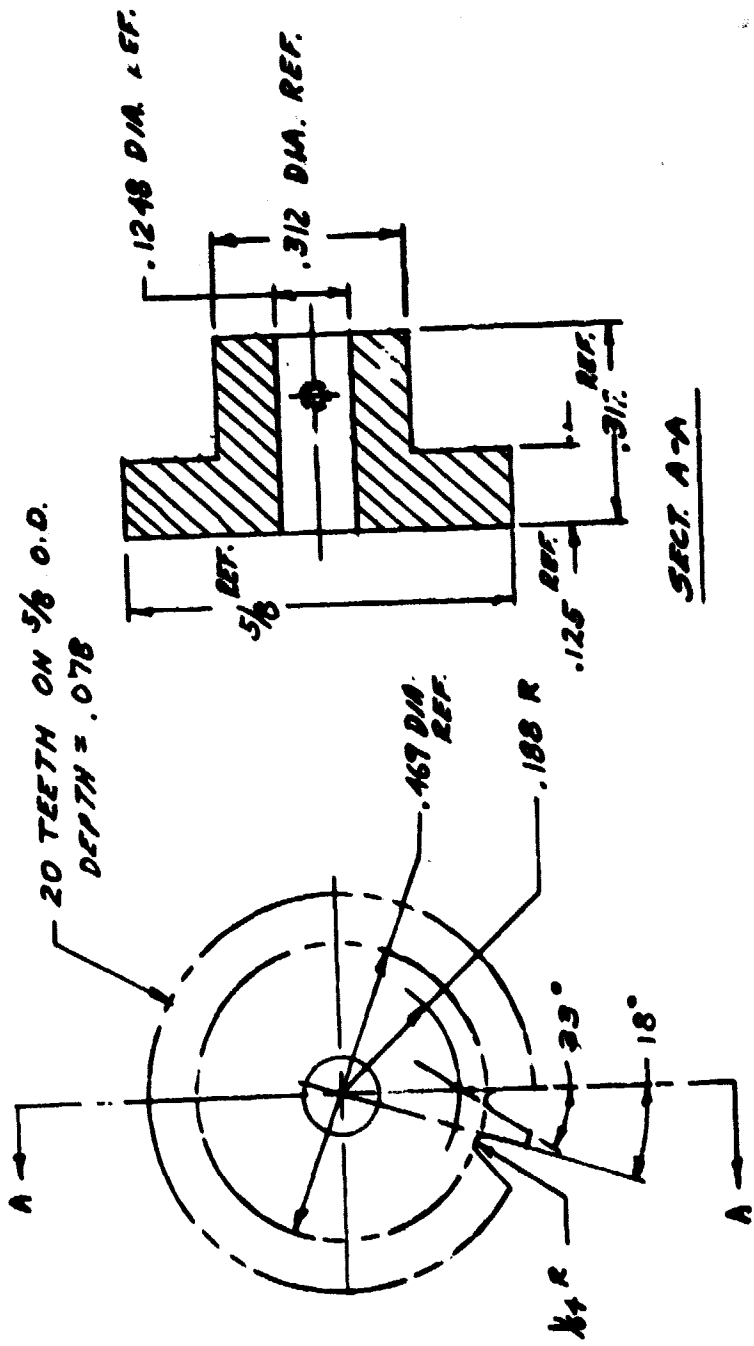

SECT. A-A

SCALE: 4:1
 MATERIAL: NOTED (PIC CORP., RIDGEFIELD, CONN.)
 TOL.: $\pm 1/64$, $\pm .005$, $\pm 1/4$
 FINISH: 32

GEAR BLANK NO.	MATERIAL
BL 1 - 5	303 SS
BL 2 - 5	2024 AL
BL 4 - 5	PHENOLIC
BL 5 - 5	NYLON

6W2-6/4/79

EH13-81

Figure 19. Gear, index.

ORIGINAL PAGE IS
OF POOR QUALITY

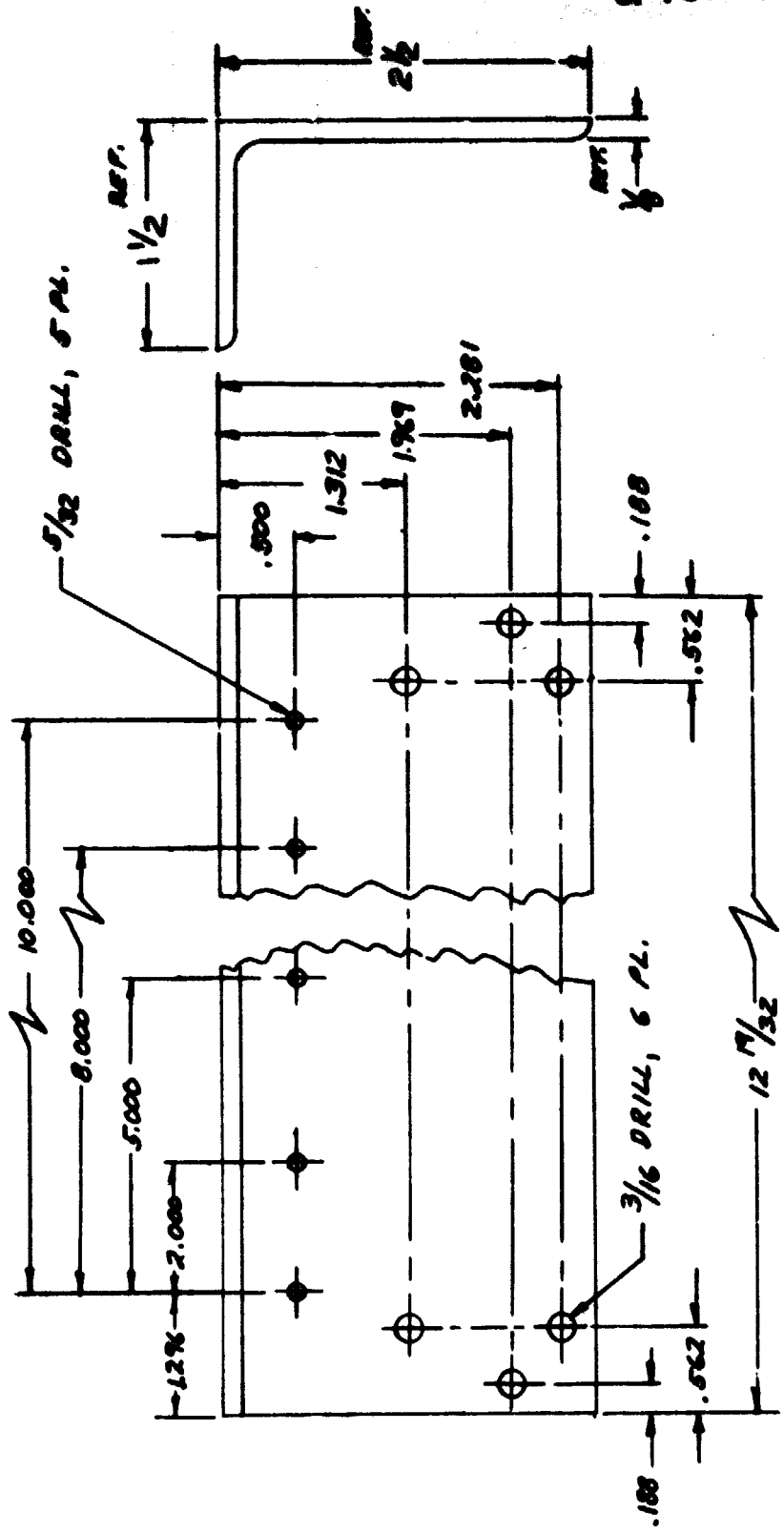

SCALE: NONE
 MATERIAL: 6061 T6 AL ANGLE, 2 1/2 x 1 1/2 x 1/8
 TOL: ± 1/4, ± 0.010
 FINISH: 125

FN13 - 33

600x - 6/6/79

Figure 20. Angle, front.

ORIGINAL PAGE IS
OF POOR QUALITY

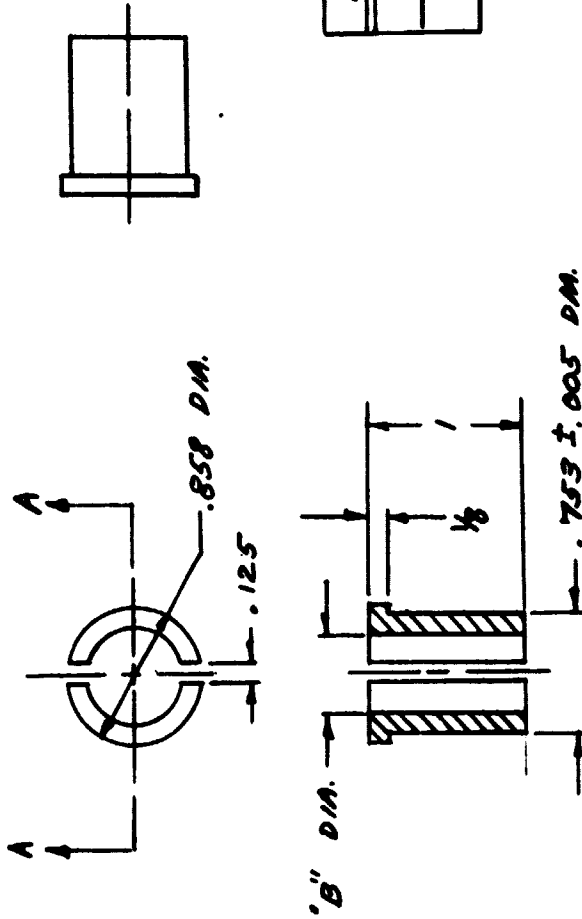

PART	"B" DIA. ±.005
-1	.516
-2	.686

SCALE: FULL
MATERIAL: 6061 T6 AL.
TOL.: ± 1/64, ±.010
FINISH: 63

SECT. A-A

EH13 - 34

GWK - 6/6/79

Figure 21. Sleeve.

ORIGINAL PAGE IS
OF POOR QUALITY

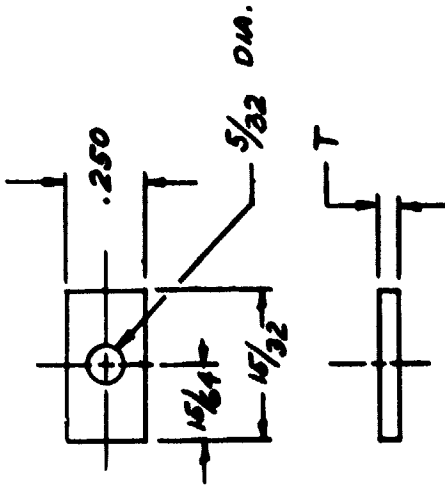

PART	T I. 006
1	.031
2	.062
3	.093

SCALE: 2:1
MATERIAL: 6061-T6 AL.
TOL. $\pm 1/64$, $\pm .010$
FINISH: 63

EN 13-36

GME 12/8/79
RVT - 1/80

Figure 23. Shim.

ORIGINAL PAGE IS
OF POOR QUALITY

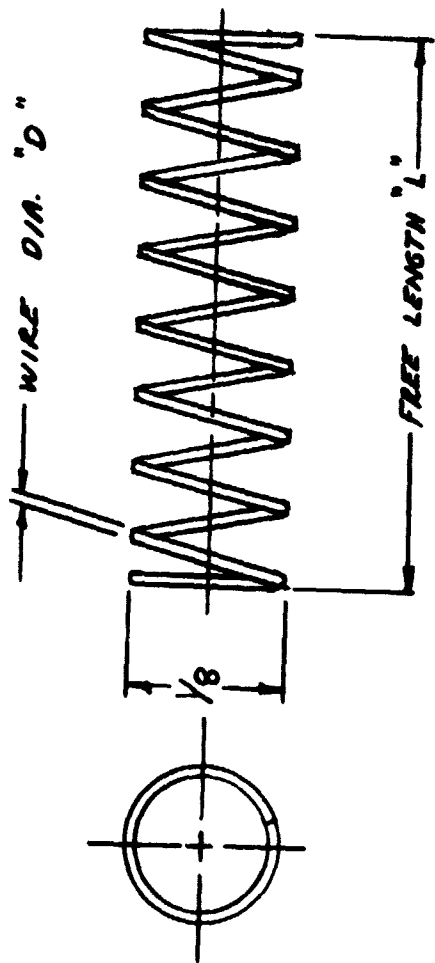

P/N	D	L
AY-32	.016	1/4
AY-36	.018	3/8
AY-40	.020	3/8
AY-34	.016	1/2

SCALE: NONE
 MATERIAL: 302 SS (PIC CORP., RIDGEFIELD,
 CONN.)
 TDL: PER VENDOR
 FINISH: PER VENDOR

GWK - 12/10/71

EH13-37

Figure 24. Spring

ORIGINAL PAGE IS
OF POOR QUALITY

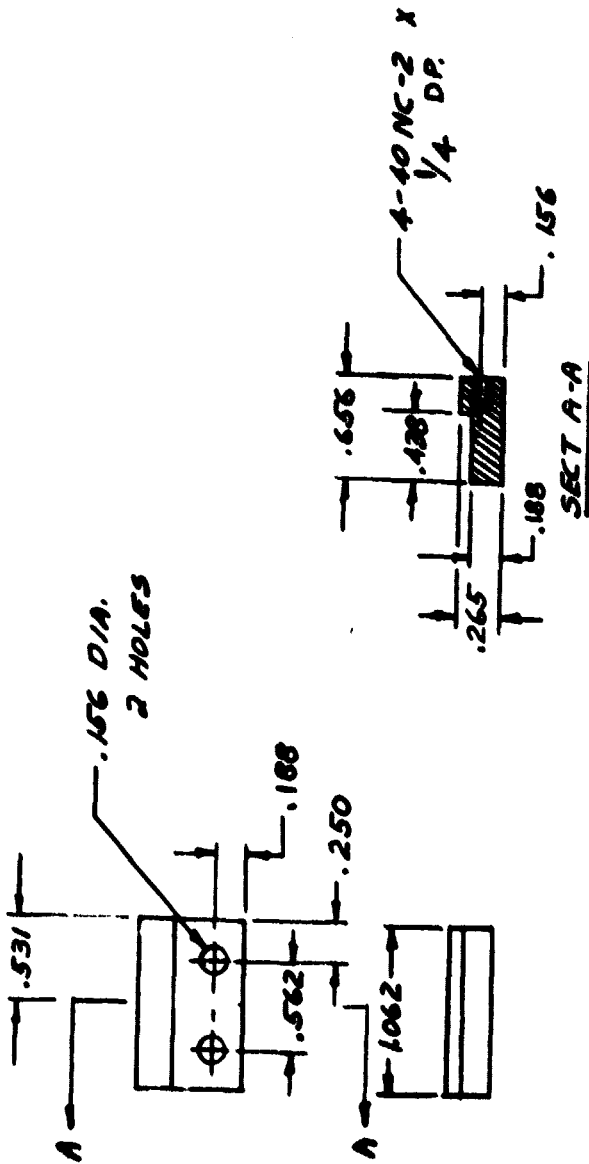

SCALE: FULL
MATERIAL: 6061 T6 AL
TOL.: ± .010 ± 1/64
FINISH: 63

6WK 1/22/80

ENAS - 37

Figure 25. Specer.

ORIGINAL PAGE IS
OF POOR QUALITY

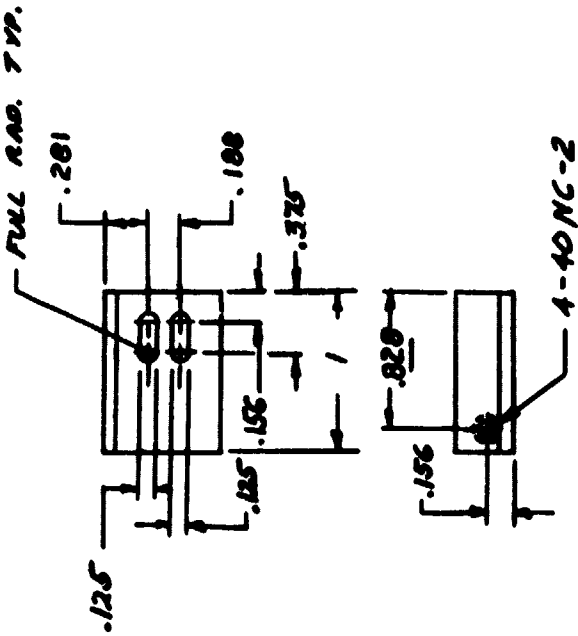

SCALE: FULL
MATERIAL: 6061 T6 AL STD. ANGLE - 3/4 x 3/8 x 3/32
TOL.: ± .010, ± 1/64
FINISH: 125

END - N

6061 - V23/80

Figure 27. Bracket

ORIGINAL PAGE IS
OF POOR QUALITY

EN 13 - 42

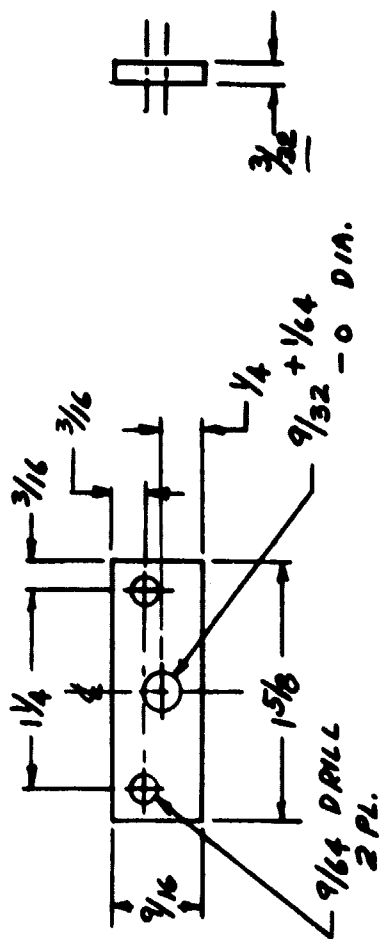

SCALE: FULL
MATERIAL: 6061 T6 AL
TOL. : $\pm \frac{1}{64}$
FINISH: 125

GWK 1/23/80

Figure 28. Plate.

ORIGINAL PAGE IS
OF POOR QUALITY

EN 13 - 13

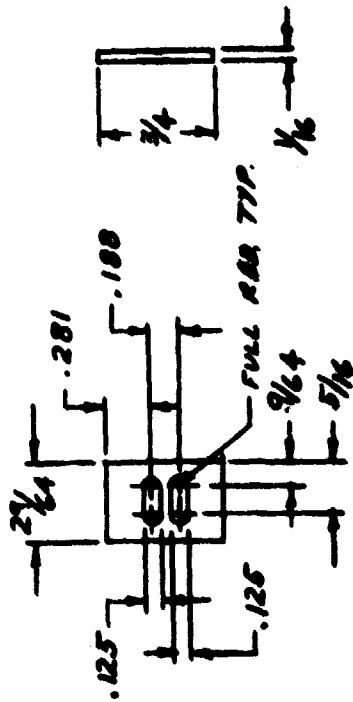

SCALE : FULL
MATERIAL : 6061 T6 AL
TOL. : ± .010 , ± $\frac{1}{16}$
FINISH : 125

6061 - 1/24/00

Figure 29. Shim.

ORIGINAL PAGE IS
OF POOR QUALITY

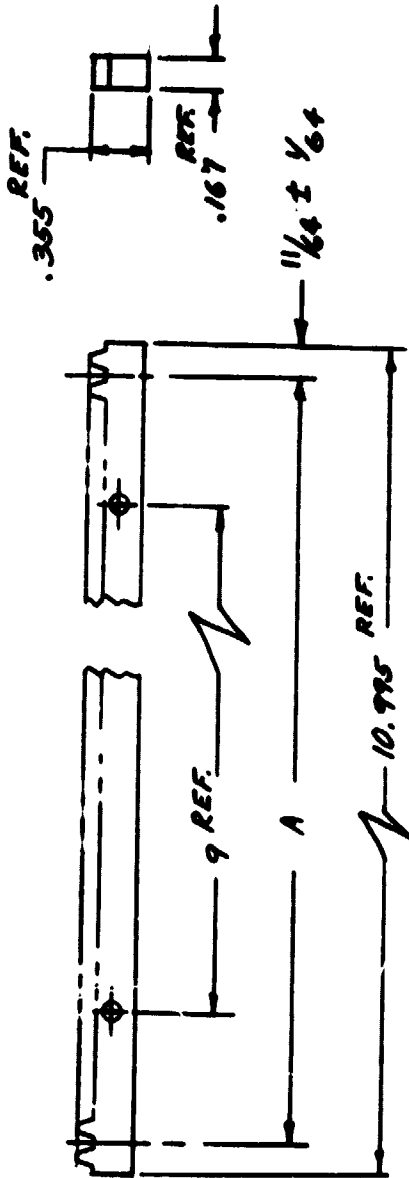

NOTE: MACHINE RACK TO "A" LENGTH OF 10.656 ± .010
MAKE FROM RACK # AG-36 PI (PIC CORP.)

SCALE: FULL
MATERIAL: PER #AG-36 PI (416 S.S.)
TOL.: AS SPECIFIED
FINISH: 125

600 - 1/24/80

EH13-44

Figure 30. Rack.

ORIGINAL PAGE IS
OF POOR QUALITY

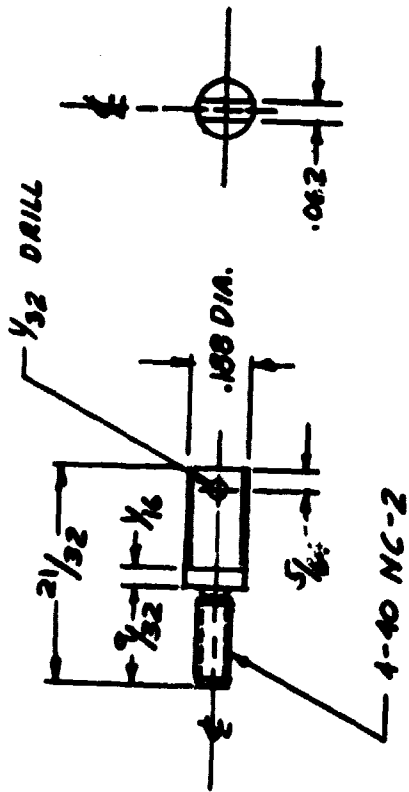

SCALE: 2:1
MATERIAL: 303 STAINLESS STE.
TOLERANCE: $\pm \frac{1}{16}$, $\pm .010$
FINISH: 63

NOTE: BREAK SHARP EDGES

GWK-12/17/00

EN13-46

Figure 32. Stanchion.

ORIGINAL PAGE #
OF POOR QUALITY

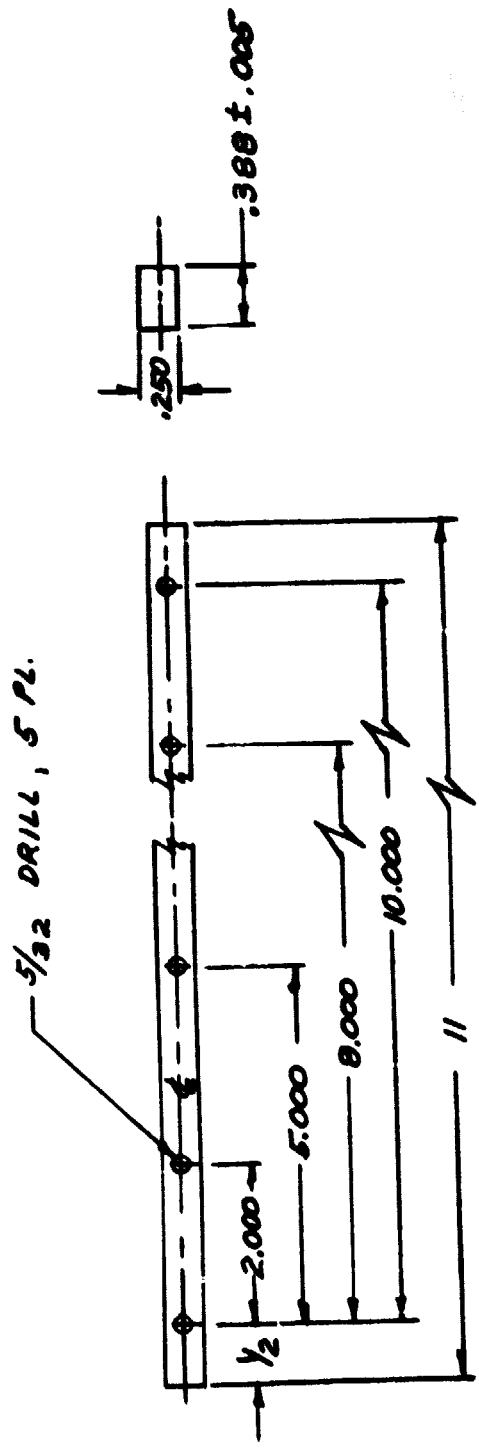

SCALE: FULL
MATERIAL: 6061 T6 AL
TOLERANCE: $\pm \frac{1}{64}$, $\pm .010$
FINISH: 125

EN13-47

602-12/17/00

Figure 33. Spacer.

ORIGINAL PAGE IS
OF POOR QUALITY

EN 15-98

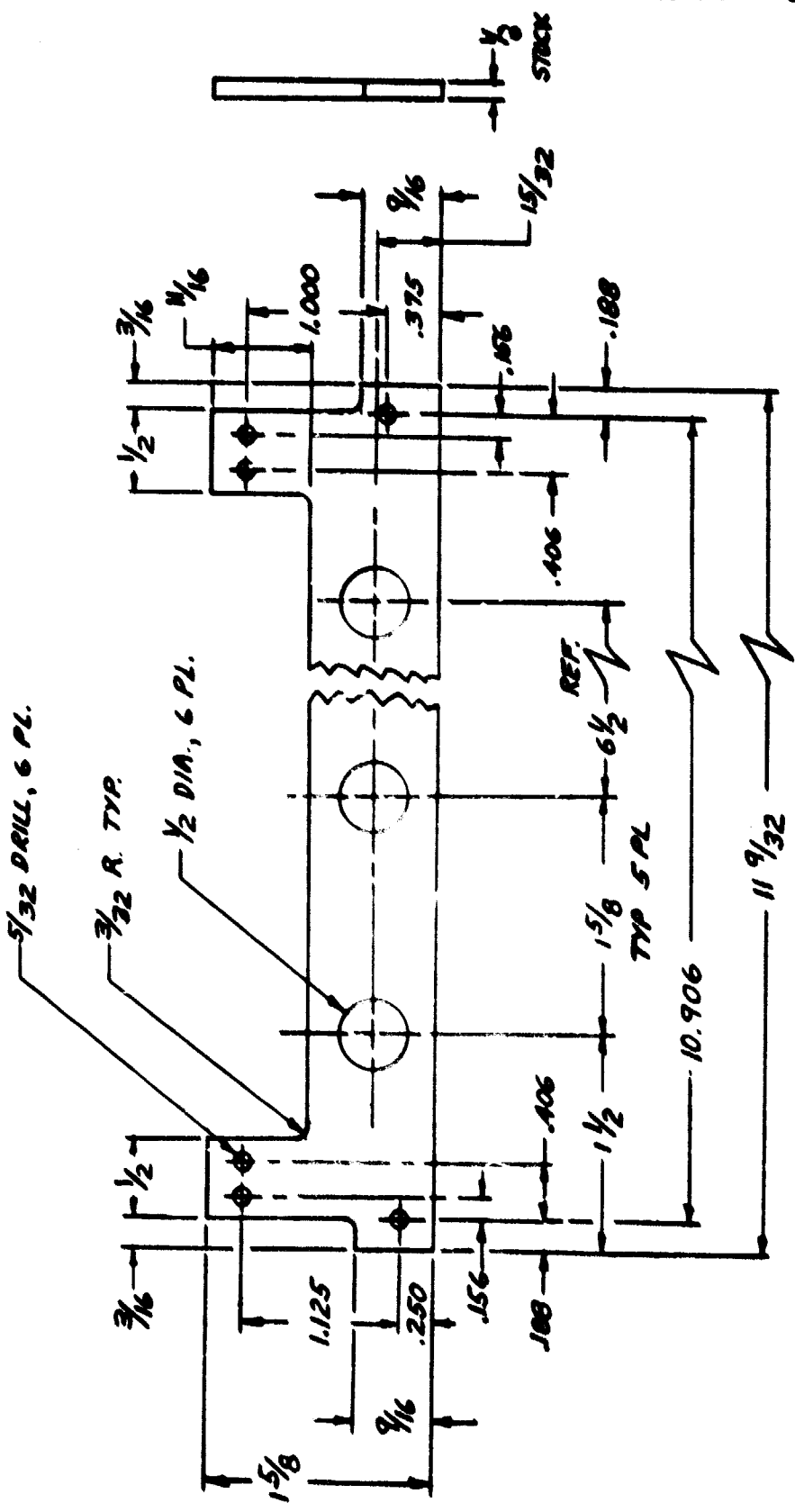

SCALE: FULL
MATERIAL: 6061-T6 AL
TOL: ± 1/64, ± .010
FINISH: 6.3

6WE-10/31/80

Figure 34. Stiffener.

REPRODUCTION

**ORIGINAL PAGE IS
OF POOR QUALITY**

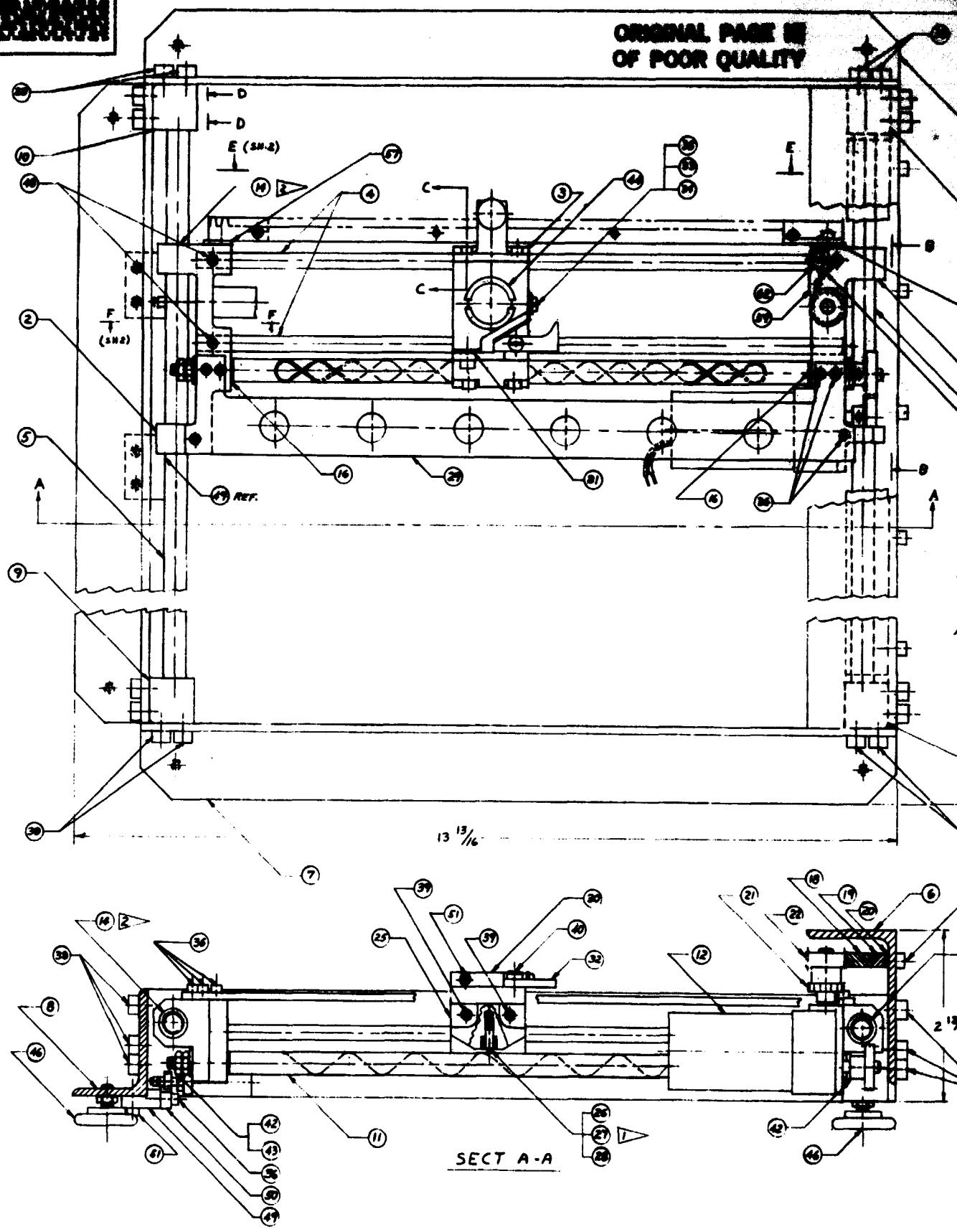

MOLDOUT FRAME

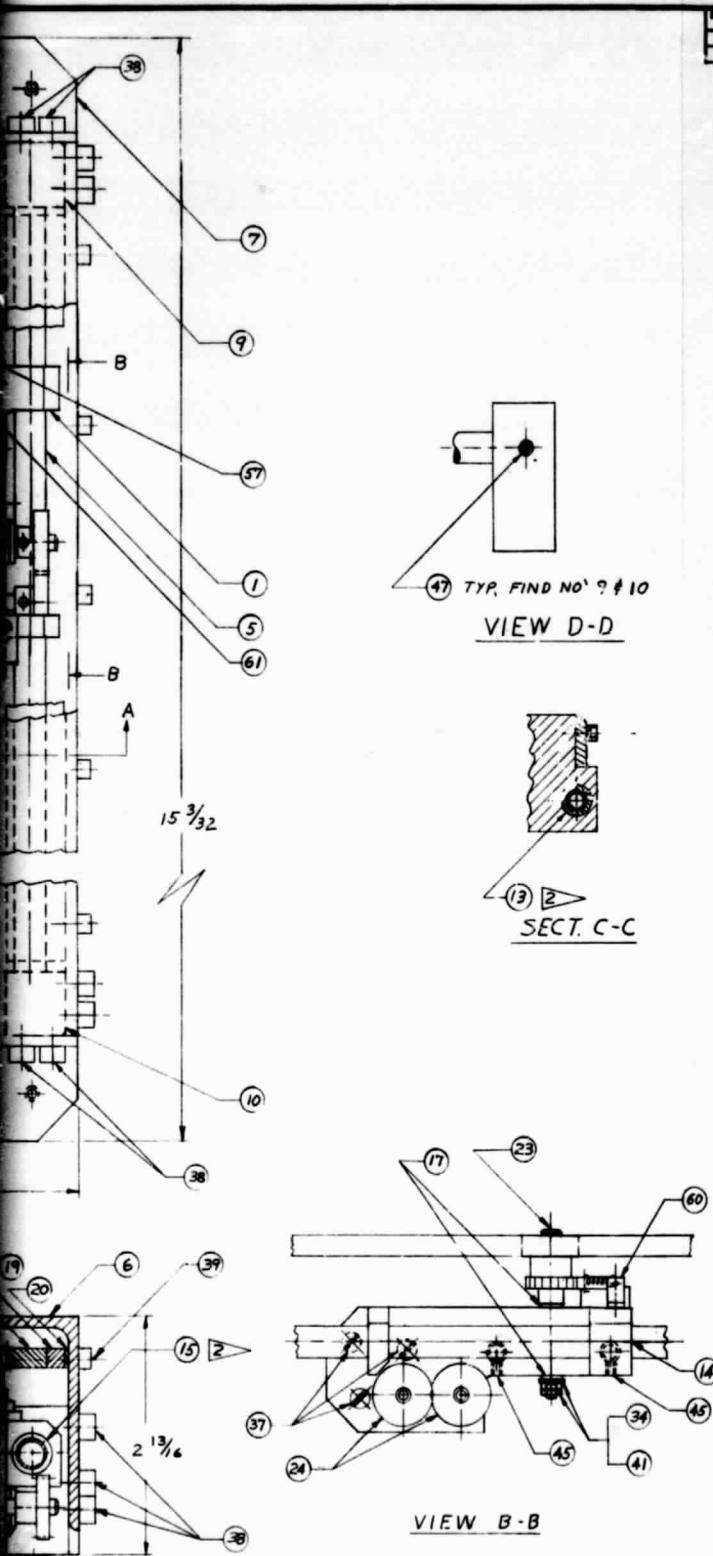

REV	DATE	DESCRIPTION	BY	APP

FIND NO.	PART NO.	PART NAME/NOMENCLATURE	QUAN.	VENDOR
1	EH13-16-1	MAIN SLIDE SUPPORT	1	
2	EH13-17-4	SLIDE SUPPORT	1	
3	EH13-18	SADDLE	1	
4	EH13-19-2	SUPPORT TUBE	2	
5	EH13-19-1	SUPPORT TUBE	2	
6	EH13-33	ANGLE, FRONT	1	
7	EH13-27	ANGLE, SIDE	2	
8	EH13-29	ANGLE, REAR	1	
9	EH13-28	CORNER BLOCK	2	
10	EH13-20	CORNER BLOCK	2	
11	EH13-30	SCAN SHAFT	1	
12		D.C. MOTOR #FYOH-63310-20 (12 VOLT, 450 RPM) WITH GEARHEAD #FYOH (9.90:1 RATIO)	1	BARBER COLMAN CO.
13	B10-12	BEARING, BRONZE, OIL-IMPREGNATED, PLAIN, 1/4 I.D. x 3/8 LG.	4	PIC CORP.
14	B10-19	BEARING, BRONZE, OIL-IMPREGNATED, PLAIN, 5/8 I.D. x 1/2 LG.	3	PIC CORP.
15	B10-17	BEARING, BRONZE, OIL-IMPREGNATED, PLAIN, 1/8 I.D. x 1/4 LG.	1	PIC CORP.
16	B11-8	BEARING, BRONZE, OIL-IMPREGNATED, FLANGED, 3/16 I.D. x 5/8 LG.	2	PIC CORP.
17	B11-3	BEARING, BRONZE, OIL-IMPREGNATED, FLANGED, 1/8 I.D. x 3/8 LG.	2	PIC CORP.
18	AG34PI	RACK, 48 PITCH, 10.99 LG	1	PIC CORP.
19	EH13-47	SPACER	1	
20		SHIM, BRASS Y6+-V32 THICK	AR	
21	EH13-32	GEAR, INDEX, 1/8 BORE x 5/8 O.D.	1	PIC CORP.
22	383-20	GEAR, SPUR, 0.6166 P.DIA., 20 TEETH	1	PIC CORP.
23	EH13-26	BEARING PIN	1	
24	65-34010	SPUR GEAR, .7083 P.DIA., 34 TEETH	2	PIC CORP.
25	EH13-22	RETAINER	1	
26	EH13-37	SPRING	1	PIC CORP.
27	EH13-31	SCAN PIN	1	
28	E3-5	PRECISION BALL BEARING, 1/4 O.D.	2	PIC CORP.
29	EH13-48	STIFFENER	1	
30	EH13-35	POSITIONER	1	
31	EH13-36	SHIM	1	
32	EH13-21	RATCHET	1	
33	EH13-23	SPRING, RATCHET	1	
34	Y7-4	WASHER, PLAIN, STL #4	2	PIC CORP.
35	Y4-4-T	SCREW, BINDING, HD - #4-40 x 1/4 LG.	1	PIC CORP.
36	Y5-4-U	SCREW, SOC. HD - #4-40 x 5/16 LG.	18	PIC CORP.
37	Y3-4-U	SCREW, FLAT HD - #4-40 x 7/16 LG.	3	PIC CORP.
38	Y5-8-V1	SCREW, SOC. HD - #8-32 x 1/16 LG.	28	PIC CORP.
39	Y5-6-Y	SCREW, SOC. HD - #6-32 x 3/8 LG.	7	PIC CORP.
40	4310	SCREW, SHOULDER, 1/8" - #4-40 THD	1	PIC CORP.
41	Y8-4	NUT, HEX - #4-40	2	PIC CORP.
42	Y7-8	WASHER, PLAIN, STL, #8	3	PIC CORP.
43	Y8-8	NUT, HEX - #8-32	2	PIC CORP.
44	EH13-34	SLEEVE	1	
45	CS-9	SET SCREW - #4-40 x 5/32 LG	2	PIC CORP.
46	2500 T1	STEM GLIDE - #8-32 THD.	1	Mc MASTER CARR SUPPLY CO.
47	CS-10	SET SCREW - #6-32 x 5/32 LG	4	PIC CORP.
48	CS-26	SET SCREW - #4-40 x 13/32 LG	5	PIC CORP.
49	EH13-39	SPACER	3	
50	AG36PI	RACK, 72 PITCH, 10.99 LG.	1	PIC CORP.
51	COMM4L	SCREW, SOC. HD - #5-40 x 5/16 LG, 32	11	
52	EH13-40	BRACKET	1	
53	EH13-44	RACK	1	
54	EH13-41	BRACKET	2	
55	EH13-42	PLATE	1	
56	61420010	SPUR GEAR, 72 PITCH, 20 TEETH	2	PIC CORP.
57	EH13-43	SHIM	2	
58		POTENTIOMETER - MOD. 3700 S-1, 1000 OHM	2	BOURNS INC INSTR. DIV.
59	EH13-45	PAWL	1	
60	EH13-46	STANCHION	1	
61	A2-22	SPRING, 1/16 O.D. x .008 WIRE x 1/2 LG	1	PIC CORP.
62	4312	SCREW, SHOULDER, 1/4" - 4-40 THD	1	PIC CORP.

NOTES:
 1. APPLY LUBRIPLATE TO FIND NO'S 11 & 27 AT HELIX AREA
 2. STAKE BEARING IN PLACE

UNLESS OTHERWISE SPECIFIED		ORIGINAL DATE OF DRAWING 11 DEC 79	GEORGE C. MARSHALL SPACE FLIGHT CENTER NATIONAL AERONAUTICS AND SPACE ADMINISTRATION HUNTSVILLE, ALABAMA
SEE ENGINEERING RECORDS	DESIGNER AND IN CHARGE	DESIGNED BY: G.W.K.	
NEXT ASSY USED ON	MATERIAL	APPROVED	DRAWING NO. EH 13-38 SHEET 1 OF 2
APPLICATION	FINAL PROTECTIVE FINISH	ISSUED	NAME FULL DATE TIME

Figure 35. X-Y scanner assembly. 39

FOLDOUT FRAME 2

Notice - When Government drawings, specifications, or other data are used for any purpose other than in connection with a definitely related Government procurement operation, the United States Government thereby incurs no responsibility nor any obligation whatsoever; and the fact that the Government may have furnished, furnished, or in any way modified the said drawings, specifications or other data is not to be construed by implication or otherwise as in any manner releasing the holder or any other person or corporation, or conveying any rights or permission to manufacture, use, or sell any patented invention that may in any way be related thereto.

PART No. _____

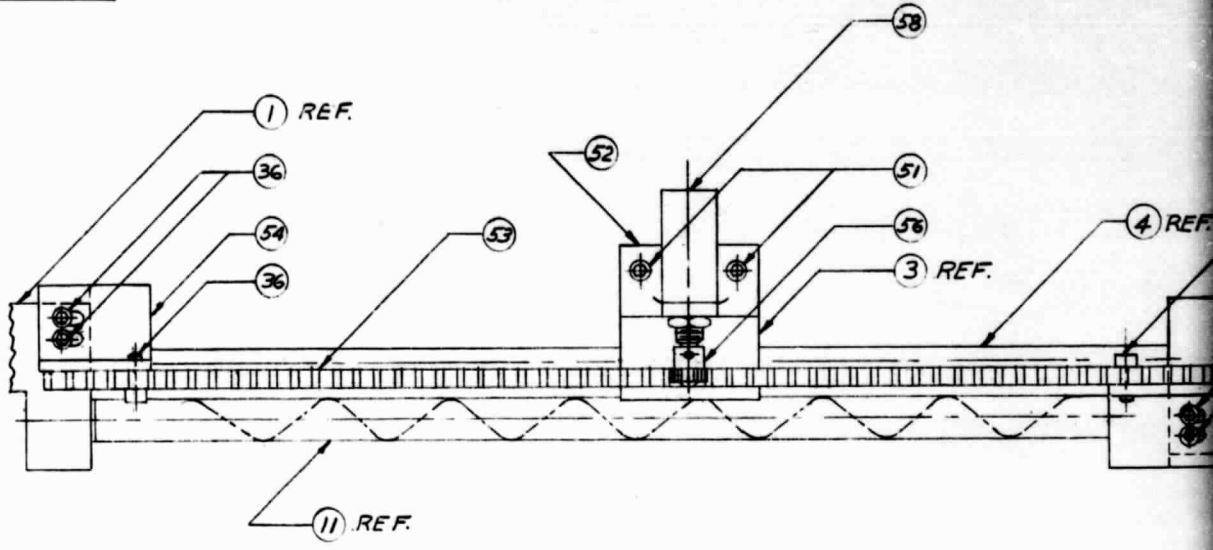

VIEW E-E (PARTIAL)

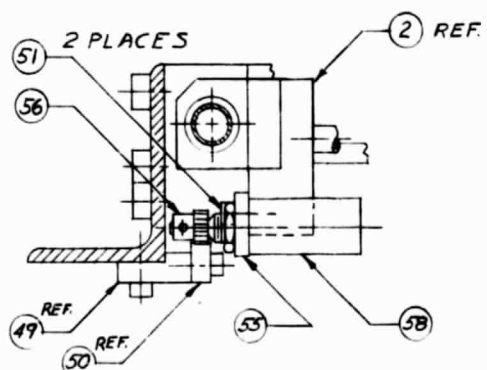

VIEW F-F (PARTIAL)

ORIGINAL PAGE IS
OF POOR QUALITY

EOLDOUT FRAME

		UNLESS OTHERWISE SPECIFIED			ORIGINAL DATE OF DRAWING 7 FEB	
		DIMENSIONS ARE IN INCHES			DRAFTSMAN GWK CHECKED	
		TOLERANCES ON FRACTIONS DECIMALS ANGLES			CHECKER BYESS	
SEE ENGINEERING RECORDS					ENGINEER GWK ENGINEER	
		MATERIAL			SUBMITTED	
		HEAT TREATMENT			APPROVED	
NEXT ASSY	USED ON	FINAL PROTECTIVE FINISH				
APPLICATION						

BRUNING 40-105 26638

PART No.		REV. #		REVISIONS			
ZONE	SYM	DESCRIPTION		DATE	APPROVAL		

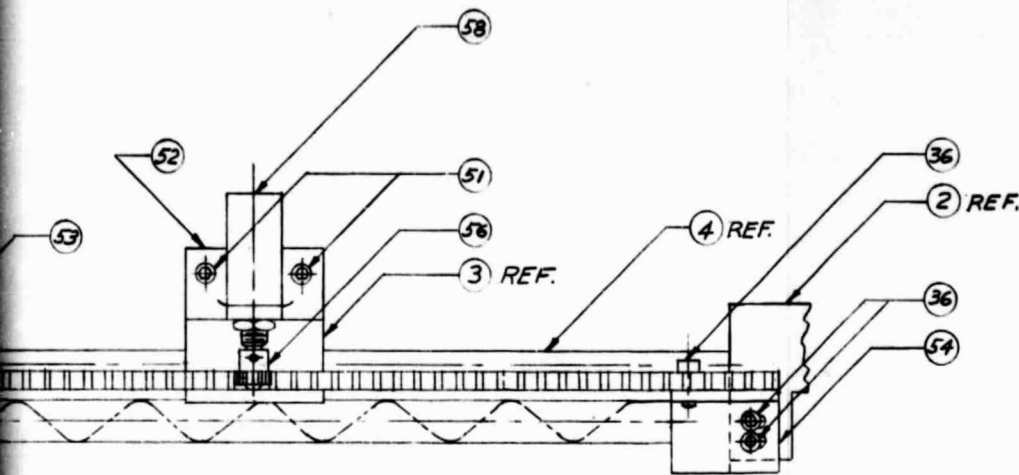

VIEW E-E (PARTIAL)

ORIGINAL PAGE IS
OF POOR QUALITY

2 FOLDOUT FRAME

UNLESS OTHERWISE SPECIFIED		ORIGINAL DATE OF DRAWING 7 FEB 80		X-Y SCANNER ASSY		GEORGE C. MARSHALL SPACE FLIGHT CENTER NATIONAL AERONAUTICS AND SPACE ADMINISTRATION HUNTSVILLE, ALABAMA		
DIMENSIONS ARE IN INCHES		DRAFTSMAN GWK						DWG SIZE C
TOLERANCES ON FRACTIONS DECIMALS ANGLES		CHECKER STRESS						EH13-38
MATERIAL		ENGINEER GWK						
HEAT TREATMENT		SUBMITTED		WEIGHT CHECKER	DATE	CODE	SHEET 2 OF 2	
FINAL PROTECTIVE FINISH		APPROVED		SCALE FULL	UNIT WEIGH.			
ENGINEERING ORDS	ASSY USED ON APPLICATION	DIRECTOR						

Figure X-Y scanner assembly.