

NASA-TM-83054

NASA Technical Memorandum 83054

NASA-TM-83054 19830014841

Noise of the 10 Bladed, 60° Swept SR-5 Propeller in a Wind Tunnel

James H. Dittmar, George L. Stefko, and Robert J. Jeracki
*Lewis Research Center
Cleveland, Ohio*

February 1983

LIBRARY COPY

APR 20 1983

LANGLEY RESEARCH CENTER
LIBRARY, NASA
HAMPTON, VIRGINIA

NASA



NF00358

87

1

1 RM/NASA-TM-83054

DISPLAY 87/2/1

83N23112**# ISSUE 12 PAGE 1964 CATEGORY 71 RPT#: NASA-TM-83054
E-1508 NAS 1.15:83054 83/02/00 12 PAGES UNCLASSIFIED DOCUMENT

UTTL: Noise of the 10-bladed 60 deg swept SR-5 propeller in a wind tunnel

AUTH: A/DITTMAR, J. H.; B/STEFKO, G. L.; C/JERACKI, R. J.

CORP: National Aeronautics and Space Administration, Lewis Research Center,
Cleveland, Ohio. AVAIL:NTIS SAP: HC A02/MF A01

MAJS: /*AERODYNAMIC NOISE/*NOISE MEASUREMENT/*PROPELLERS/*WIND TUNNEL TESTS

MINS: / DIRECTIVITY/ MACH NUMBER/ PROPELLER BLADES/ TURBOPROP AIRCRAFT

ABA: M. G.

ABS: Noise generated by supersonic helical tip speed propellers is a possible cabin environment problem for future airplanes powered by these propellers. Noise characteristics of one of these propellers, designated SR-5, are presented. A matrix of tests was conducted to provide as much acoustic information as possible. During aerodynamic testing it was discovered that the propeller had an aeroelastic instability which prevented testing the propeller at its design advance ratio of 4.08 at axial Mach numbers over 0.7. Plots of the variation of the maximum blade passage tone with helical tip Mach number indicate that, at higher helical tip Mach numbers, the propeller operated on sharply increasing portion of the noise curve; therefore, extrapolations to the design condition would not be accurate. A possible extrapolation indicated that SR-5 at its design point should be quieter than SR-3 at its design point. Directivity

ENTER: PAGE

DISPLAY 87/2/1

plots at the higher helical tip Mach numbers indicate a lobed directivity pattern as was observed previously on the SR-3 propeller.

≡

NOISE OF THE 10-BLADED, 60° SWEPT SR-5 PROPELLER IN A WIND TUNNEL

James H. Dittmar, George L. Stefko, and Robert J. Jeracki

National Aeronautics and Space Administration
Lewis Research Center
Cleveland, Ohio 44135

SUMMARY

Noise generated by supersonic helical-tip speed propellers is a possible cabin environment problem for future airplanes powered by these propellers. Five models of these propellers have been designed and tested. Test results for four of these propellers were reported previously. Test results for the fifth propeller, designated SR-5, are presented in this report.

During aerodynamic testing it was discovered that the propeller had an aeroelastic instability which prevented testing the propeller at its design advance ratio of 4.08 at axial Mach numbers over 0.7. A matrix of tests was conducted to provide as much acoustic information as possible. Plots of the variation of the maximum blade passage tone with helical tip Mach number indicated that, at the higher helical tip Mach numbers, the propeller operated on a sharply increasing portion of the noise curve; therefore, extrapolations to the design condition would not be accurate. Nevertheless, based on past experience, an extrapolation indicated that SR-5 at its design point might be quieter than SR-3 at its design point. Directivity plots at the higher helical tip Mach numbers indicate a lobed directivity pattern as was observed previously for the SR-3 propeller.

INTRODUCTION

One of the candidate engines for a future energy conservative airplane is a high tip speed turboprop. When the turboprop airplane is at cruise, the combination of the airplane forward speed and the propeller rotational speed results in supersonic helical velocities over the outer portions of the propeller blades. During flight these supersonic blade sections and associated shock waves generate significant noise that might present a cabin environment problem.

In the initial investigation of the noise of this type of propeller, three propeller models designed for 244 m/sec (800 ft/sec) tip speed were tested in the NASA Lewis 8- by 6-Foot Wind Tunnel (refs. 1 to 3). Design conditions for these propellers (SR-1M, SR-2, SR-3) are shown in table I. To investigate other design point conditions two additional propellers were designed for lower tip speeds. The design conditions for SR-6 and SR-5 are also found in table I. The measured noise of the SR-6 propeller with 213 m/sec (700 ft/sec) tip speed was reported in Reference 4. The SR-5 propeller, 183 m/sec (600 ft/sec) tip speed, was tested for acoustics in the NASA Lewis 8- by 6-Foot Wind Tunnel. This report presents the data obtained during these acoustic experiments.

N93-23112#

SYMBOLS

D	propeller diameter
J	advance ratio, $J = V/ND$
M	axial Mach number
M_{ht}	helical tip Mach number (vector sum of tip rotational and axial Mach numbers)
N	propeller rotational speed, (rev/time)
V	axial velocity
θ	angle with respect to propeller axis (fig. 2)

APPARATUS AND PROCEDURE

Propeller

The 10-bladed propeller used in this test was designated the SR-5 propeller and was swept approximately 60° at the tip (see table I). The sweep distribution, hub-to-tip, was tailored to achieve some cancellation of the noise from the various blade sections. This tailored sweep concept was used previously on the SR-3 propeller but not on the other blades. The design blade setting angle was nominally 69.3° . The performance data were taken at 70.6° , near design, so the noise data were taken here also. A picture of the SR-5 propeller in the 8- by 6-Foot Wind Tunnel is shown in figure 1(a) while a plan view of this tunnel is shown in figure 1(b).

Installation and Tests

The propeller was installed in the 8- by 6- Foot Wind Tunnel and five pressure transducers were installed in the tunnel bleed holes visible in figure 1. The five transducer positions in the tunnel ceiling are shown in figure 2.

The purpose of these tests was to evaluate the noise of the propeller at the blade setting angle of 70.6° and design advance ratio of 4.08 at axial Mach numbers ranging from 0.5 to 0.85 in steps of 0.05. However, during aerodynamic testing it was discovered that the propeller had an aeroelastic instability which prevented testing at its design advance ratio at axial Mach numbers above 0.7. It was decided that the lowest advance ratio, J, that could be safely tested over the entire Mach number range was 5.1. During the actual testing the propeller was operated at its design J of nominally 4.08 up to an axial Mach number of 0.7, at a nominal J of 5.1 and 5.9 for the entire Mach number range, and at the lowest safe J of 4.80 at a Mach number of 0.8. It was hoped that some extrapolation of the curves would yield an estimate of the propeller noise at the design condition ($J = 4.08$, $M = 0.8$). In

addition, the propeller was operated at windmill for all of the Mach numbers tested. The propeller was operated at 70.6° near its design setting angle for all of these tests. A matrix of the nominal test points is shown in figure 3.

RESULTS AND DISCUSSION

The signals from the five pressure transducers were recorded on magnetic tape, and narrowband spectra from 0 to 10 000 Hz with a bandwidth of 26 Hz were taken at representative test conditions. It was determined from these spectra that the blade passage tones of this propeller were very close in frequency to the noise created by the tunnel drive compressor (see fig. 1(b)). In addition, because of the low noise level of the propeller, the harmonics of the tone were not visible even at higher Mach number conditions. Therefore spectra were taken from 0 to 1 000 Hz with a bandwidth of 2.6 Hz to determine the blade passage tone levels. The blade passage tones, read from the 0- to 1 000-Hz narrowband spectra, are compiled in table II.

As can be seen in table II, no data were available at an advance ratio of 4.08 at the tunnel Mach number of 0.55. This lack of data at Mach 0.55 occurred because the tone of the propeller was at the same frequency as one of the tunnel compressor stages and was overpowered by it. The tone was measurable at $J = 4.05$, $M = 0.50$ because, in frequency, it fell between two of the compressor tones. The combination of the low noise level and low blade passing frequency of this propeller with the broadband noise and compressor tone levels of the tunnel has resulted in this propeller being near the limit of what can be tested for acoustics in the wind tunnel. Quieter propellers with this same low rotational speed probably would not produce tones that could be separated from the tunnel background noise by conventional spectral analysis.

Variation With Helical Tip Mach Number

The maximum measured blade passing tone levels for the SR-5 propeller are plotted as a function of helical tip Mach number, M_{ht} , (vectored sum of axial and rotational Mach numbers) in figure 4. Data taken at nominal J 's of 4.08, 4.80, 5.1, where data were measured, are plotted in this figure. Curves were drawn through the data at nominal J 's of 4.08 and 5.1; both of these curves started slowly but rose rapidly at increasing helical tip Mach number. Only a single point exists for $J = 4.80$. The loading at an advance ratio of 5.1 is less than that at 4.08 which results in less noise at the same helical tip Mach number. This loading effect was previously observed on other propellers (ref. 4). The other propellers showed a rapid noise-rise portion followed by a leveling off at higher helical tip Mach numbers. The curve for one of these propellers, SR-3, which was operated at a higher power loading (table I), is also plotted in figure 4. It was not possible to test the SR-5 propeller at the higher helical tip Mach numbers, and it appears that the available data are still on the noise-rise portion of the curve. Since the data are in the sharply increasing noise-rise portion and have not yet levelled off, extrapolations of the data to the SR-5 design condition ($J = 4.08$, $M_{ht} = 1.01$) would not be very accurate. However, assuming the SR-5 will follow the same

trends as the other propellers a possible extrapolation of the 4.08 advance ratio curve in figure 4 might be to continue it slightly above the single data point at the 4.80 advance ratio, and then on above the data point at the 5.1 advance ratio (1.0 helical tip Mach number). From there the curve would level off somewhere below the SR-3 curve. This extrapolated curve shape would be consistent with the shape of the curves for the other propellers (see refs. 1-4), and might appear as the dashed line in figure 4. From this possible extrapolation it would appear that the SR-5 propeller at its design condition ($J = 4.08$, $M_{ht} = 1.01$) would be quieter than the SR-3 propeller at its design condition ($J = 3.06$, $M_{ht} = 1.14$). Evaluation of the difference does not appear possible from the data, however.

Directivity

The directivity plots for the measured noise are shown in figure 5. At a number of helical tip Mach numbers only one or two of the transducer positions showed measureable noise levels, and, consequently, directivities were not plotted at these conditions. At conditions where sufficient data were available, the directivities are included in figure 5. In figures 5(b), (c), and (e) the directivities show a lobed pattern with what appears to be one lobe ahead of the propeller and one behind.

The lobed pattern was observed previously on the SR-3 propeller (ref. 3) and the SR-6 propeller (ref. 4). The existence of a lobed pattern in the noise field of these propellers could have a significant effect on the design of an airplane using these propellers. A minimum noise area in the directivity pattern might affect the passenger placement inside the airplane and the type and placement of cabin wall acoustic treatment.

CONCLUDING REMARKS

The SR-5 propeller was tested for acoustics in the NASA Lewis 8- by 6-Foot Wind Tunnel. During aerodynamic testing it was discovered that the propeller had an aeroelastic instability which prevented testing the propeller at its design advance ratio of 4.08 at axial Mach numbers above 0.7. A matrix of tests was conducted to provide as much information as possible. This matrix included testing over the entire range of axial Mach numbers (0.5 to 0.85) at a safe advance ratio of nominally 5.1, testing at the nominal design advance ratio 4.08 up to a Mach number of 0.7, and a test point at an axial Mach number of 0.8 with an advance ratio of nominally 4.8. Plots of the variation of the maximum blade passage noise with helical tip Mach number indicate that at the higher helical tip Mach numbers the propeller still operated on the sharply increasing portion of the noise curve. Therefore extrapolations of the design advance ratio noise curve to the actual design condition at a higher helical tip Mach number would not be very accurate. Nevertheless, based on past experience, an extrapolation of the design advance ratio noise curve, $J = 4.08$, indicates that the SR-5 propeller at its design point might be quieter than the SR-3 propeller at its design point. Directivity plots at the higher helical tip Mach number conditions indicated a lobed directivity pattern as was observed previously on the SR-3 propeller.

REFERENCES

1. Dittmar, J. H., Blaha, B. J., and Jeracki, R. J.: Tone Noise of Three Supersonic Helical Tip Speed Propellers in a Wind Tunnel at 0.8 Mach Number. NASA TM-79046, Dec. 1978.
2. Dittmar, J. H., Jeracki, R. J., and Blaha, B. J.: Tone Noise of Three Supersonic Helical Tip Speed Propellers in a Wind Tunnel. NASA TM-79167, June 1979.
3. Dittmar, J. H. and Jeracki, R. J.: Additional Noise Data on the SR-3 Propeller. NASA TM-81736, May 1981.
4. Dittmar, J. H., Stefko, G. L., and Jeracki, R. J.: "Noise of the 10 Bladed 40° Swept SR-6 Propeller in a Wind Tunnel." NASA TM-82950, 1982.

TABLE I. - DESIGN CHARACTERISTICS OF HIGH SPEED PROPELLER MODELS

	SR-2	SR-1M	SR-3	SR-6	SR-5
Tip sweep angle, deg	0	30	45	40	60
Propeller diameter, cm (in.)	62.2(24.5)	62.2(24.5)	62.2(24.5)	69.6(27.4)	62.2(24.5)
Tip speed, m/sec (ft/sec)	244(800)	244(800)	244(800)	213(700)	183(600)
Power loading, P/d^2 , kW/m^2 (hp/ft^2)	301(37,5)	301(37,5)	301(37,5)	241(30,0)	209(26.0)
Number of blades	8	8	8	10	10
Advance ratio, J	3.06	3.06	3.06	3.5	4.08
Helical tip Mach number	1.15	1.15	1.15	1.07	1.01

TABLE II. - BLADE PASSAGE TONE NOISE

Tunnel Mach number, M	Propeller advance ratio, J	Helical tip Mach number, M_{ht}	Power coefficient, C_p	Propeller speed, rpm	Blade passage tone SPL, dB ref 2×10^{-5} N/m ²				
					Transducer				
					1	2	3	4	5
a 0.5	4.049	0.635	3.54	4158	(h)	110.5	(h)	111.0	(h)
b .6	4.041	.758	3.40	4956	(h)	115.5	(h)	115.0	(h)
c .65	4.110	.820	3.32	5272	(h)	117.0	116.5	115.0	115.5
d .70	4.110	.887	3.22	5677	123.5	129.5	123.5	127.0	122.0
e .75	5.048	.876	2.41	4852	(h)	122.0	118.0	(h)	(h)
f .80	5.080	.943	2.35	5144	121.0	122.0	124.0	(h)	121.5
.80	4.780	.958	2.63	5462	123.0	128.5	127.5	134.5	122.0
g .85	5.120	.997	2.27	5365	119.0	135.5	132.0	136.0	120.5

^aNo tones visible at M = 0.5 for J's of 5.9, 5.1 and windmill. No tones visible at M = 0.55 for J's of 5.9, 5.1, 4.08 and windmill.

^bNo tones visible at M = 0.6 for J's of 5.9, 5.1 and windmill.

^cNo tones visible at M = 0.65 for J's of 5.9, 5.1 and windmill.

^dNo tones visible at M = 0.70 for J's of 5.9, 5.1 and windmill.

^eNo tones visible at M = 0.75 for J's of 5.9 and windmill.

^fNo tones visible at M = 0.80 for J's of 5.9 and windmill.

^gNo tones visible at M = 0.85 for J's of 5.9 and windmill.

ⁿNo tones visible above tunnel background.

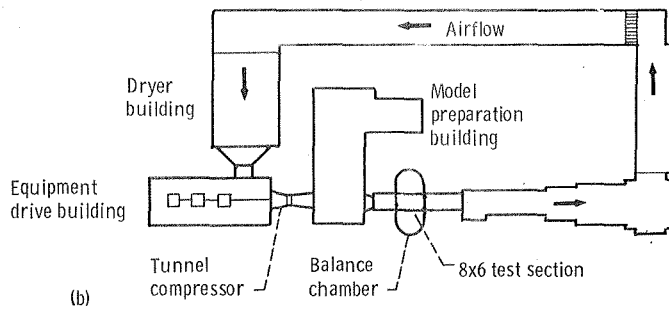
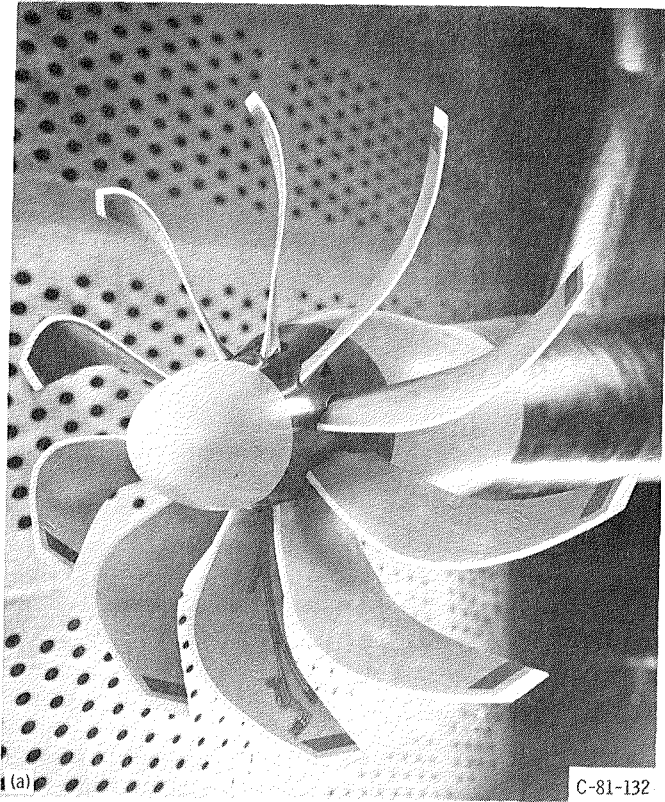

(a) SR-5 propeller in test section.

(b) Plan view of 8- by 6-foot wind tunnel.

Figure 1. - Wind tunnel and propeller installation.

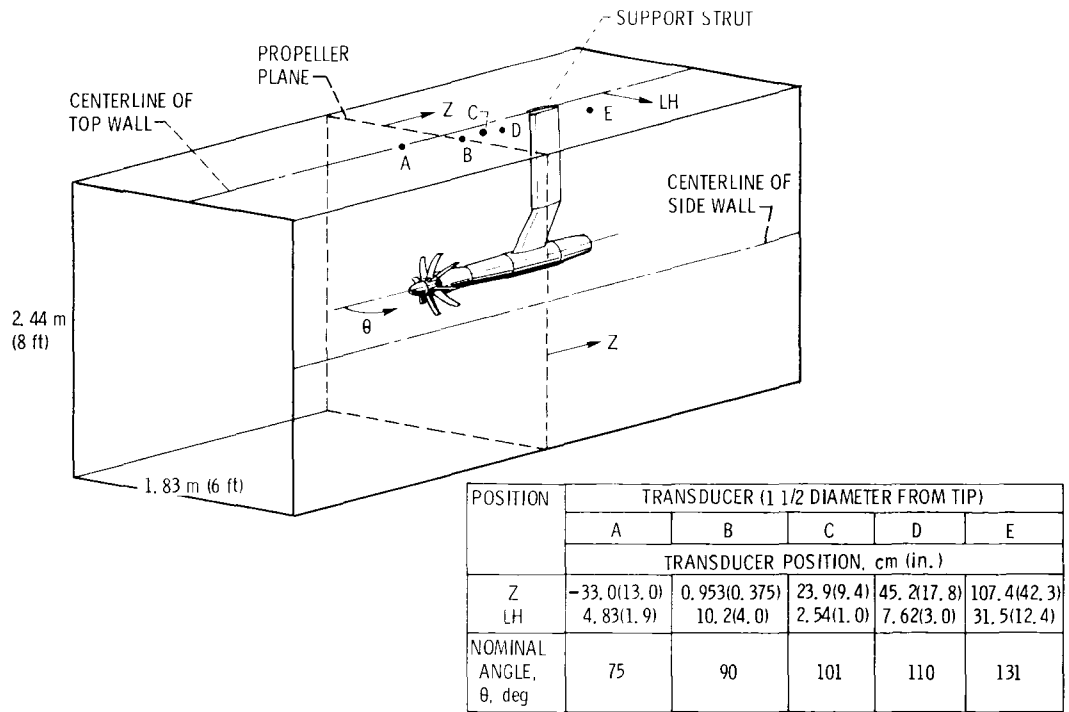

Figure 2. - Pressure transducer positions.

Nominal test point

		Advance ratio				
		4.08	4.80	5.10	5.90	Wind-mill
A x i a l M a c h n u m b e r	0.50	<input checked="" type="checkbox"/>		<input checked="" type="checkbox"/>	<input checked="" type="checkbox"/>	<input checked="" type="checkbox"/>
	0.55	<input checked="" type="checkbox"/>		<input checked="" type="checkbox"/>	<input checked="" type="checkbox"/>	<input checked="" type="checkbox"/>
	0.60	<input checked="" type="checkbox"/>		<input checked="" type="checkbox"/>	<input checked="" type="checkbox"/>	<input checked="" type="checkbox"/>
	0.65	<input checked="" type="checkbox"/>		<input checked="" type="checkbox"/>	<input checked="" type="checkbox"/>	<input checked="" type="checkbox"/>
	0.70	<input checked="" type="checkbox"/>		<input checked="" type="checkbox"/>	<input checked="" type="checkbox"/>	<input checked="" type="checkbox"/>
	0.75			<input checked="" type="checkbox"/>	<input checked="" type="checkbox"/>	<input checked="" type="checkbox"/>
	0.80		<input checked="" type="checkbox"/>	<input checked="" type="checkbox"/>	<input checked="" type="checkbox"/>	<input checked="" type="checkbox"/>
	0.85			<input checked="" type="checkbox"/>	<input checked="" type="checkbox"/>	<input checked="" type="checkbox"/>

Figure 3. - Propeller test matrix.

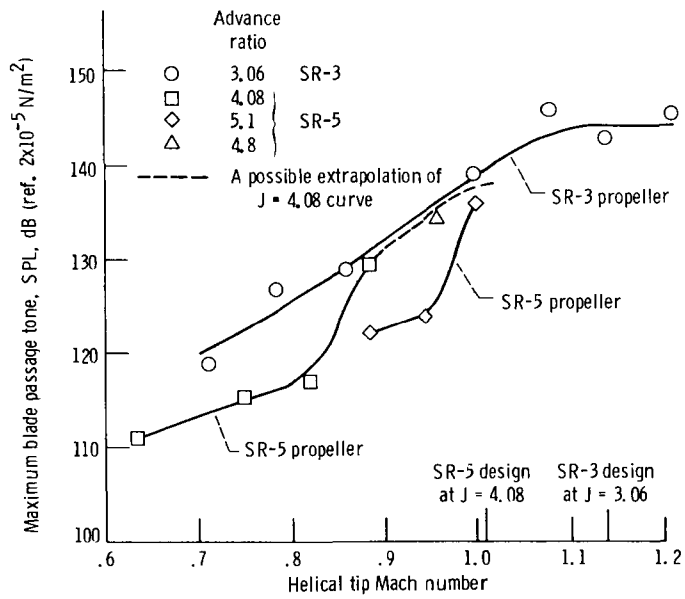

Figure 4. - Maximum blade passage tone variation with helical tip Mach number.

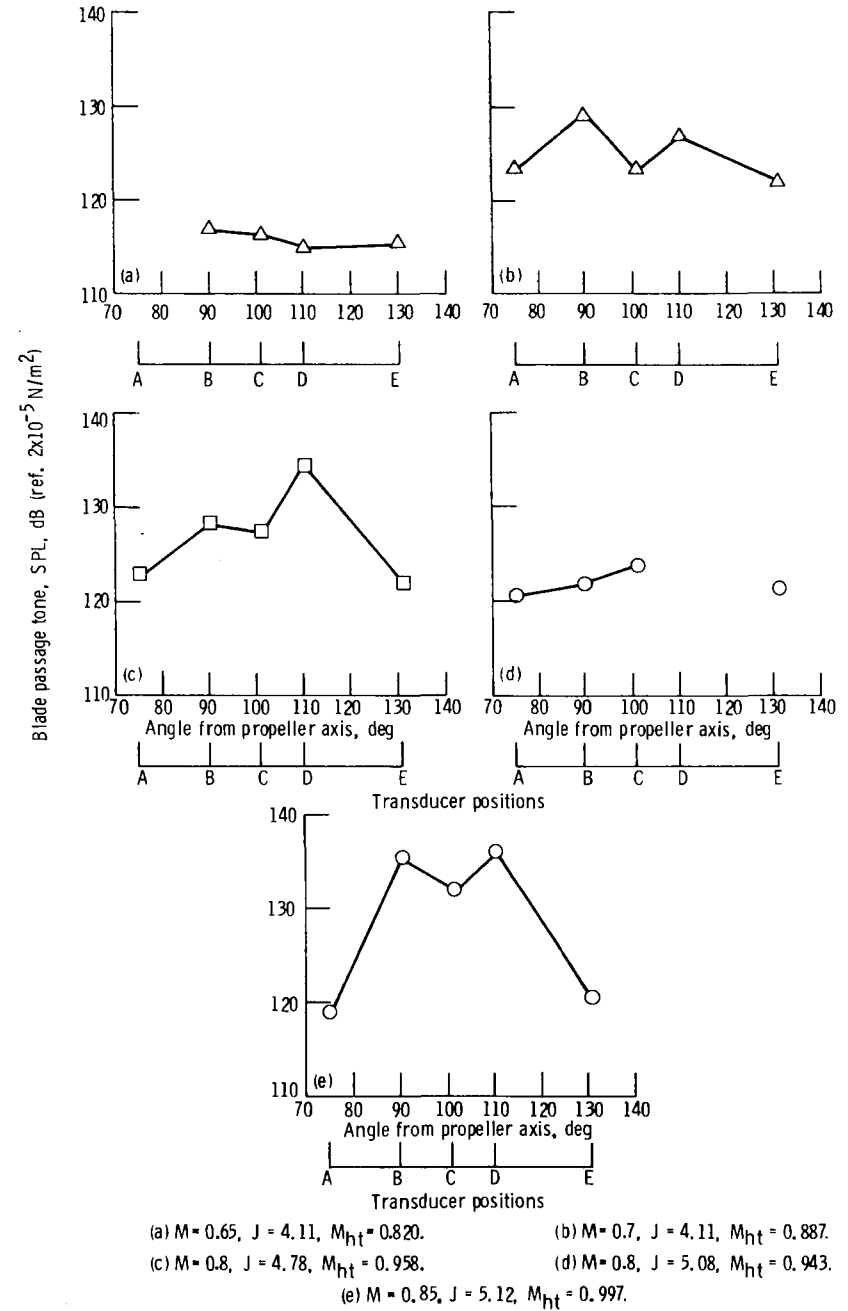

Figure 5. - Turboprop SR-5 noise directivity.

1. Report No. NASA TM-83054	2. Government Accession No.	3. Recipient's Catalog No.	
4. Title and Subtitle NOISE OF THE 10-BLADED, 60° SWEPT SR-5 PROPELLER IN A WIND TUNNEL		5. Report Date February 1983	
		6. Performing Organization Code 535-03-12	
7. Author(s) James H. Dittmar, George L. Stefko, and Robert J. Jeracki		8. Performing Organization Report No. E-1508	
		10. Work Unit No.	
9. Performing Organization Name and Address National Aeronautics and Space Administration Lewis Research Center Cleveland, Ohio 44135		11. Contract or Grant No.	
		13. Type of Report and Period Covered Technical Memorandum	
12. Sponsoring Agency Name and Address National Aeronautics and Space Administration Washington, D. C. 20546		14. Sponsoring Agency Code	
		15. Supplementary Notes	
16. Abstract <p>Noise generated by supersonic helical-tip speed propellers is a possible cabin environment problem for future airplanes powered by these propellers. Noise characteristics of one of these propellers, designated SR-5, are presented in this paper. A matrix of tests was conducted to provide as much acoustic information as possible. During aerodynamic testing it was discovered that the propeller had an aeroelastic instability which prevented testing the propeller at its design advance ratio of 4.08 at axial Mach numbers over 0.7. Plots of the variation of the maximum blade passage tone with helical tip Mach number indicate that, at higher helical tip Mach numbers, the propeller operated on sharply increasing portion of the noise curve; therefore, extrapolations to the design condition would not be accurate. A possible extrapolation indicated that Sr-5 at its design point should be quieter than SR-3 at its design point. Directivity plots at the higher helical tip Mach numbers indicate a lobed directivity pattern as was observed previously on the SR-3 propeller.</p>			
17. Key Words (Suggested by Author(s)) Propeller noise Noise Supersonic tip speed		18. Distribution Statement Unclassified - unlimited STAR Category 71	
19. Security Classif. (of this report) Unclassified	20. Security Classif. (of this page) Unclassified	21. No. of Pages	22. Price*

End of Document