

NASA Contractor Report 166118

U
Y

(NASA-CR-166118) RIDE QUALITY SYSTEMS FOR
COMMUTER AIRCRAFT Final Report (Kansas
Univ. Center for Research, Inc.) 92 P
RC A05/MF A01 CSCL 01C

NEE-24512

Unclas
G3/08 03619

RIDE QUALITY SYSTEMS FOR COMMUTER AIRCRAFT

David R. Downing, Terry A. Hammond, and
Shailesh P. Amin



THE UNIVERSITY OF KANSAS CENTER FOR RESEARCH, INC.
Flight Research Laboratory
Lawrence, Kansas 66045

Grant NAG1-282
May 1983



National Aeronautics and
Space Administration

Langley Research Center
Hampton, Virginia 23665

TABLE OF CONTENTS

1.0	INTRODUCTION	1
2.0	BASIC DEFINITIONS AND CONCEPTS	3
3.0	REVIEW OF RIDE QUALITY AUGMENTATION RESEARCH AND RELATED TECHNOLOGIES	9
4.0	DISCUSSION AND RECOMMENDATIONS	21
5.0	CONCLUSIONS	27
	APPENDIX A: RIDE TECHNOLOGY	29
	APPENDIX B: BIBLIOGRAPHY OF LITERATURE SEARCH	43
	REFERENCES	49

LIST OF FIGURES

1. Basic Analytical System
2. Influence of W/S and Lift Curve Slope (α) on Ride Bumpiness
3. Comparison of Comfort Rating for Various Airplane Types
4. RQAS Subsystems
5. Block Diagrams of Open and Closed RQAS
6. NACA RQAS Test Aircraft
7. Passenger Ride Quality During Cruise
8. Passenger Ride Quality During Descent
9. Passenger Ride Quality During Approach
10. Longitudinal Handling Qualities
11. Contrast Between Effects of W/S/ α , and an Active RQAS
12. Effect of Crew Sensitivity Index on Ride Quality
13. RQAS Control Surfaces on the DHC-6 Study
- 14a. Block Diagram of DHC-6 RQAS - Longitudinal Mode
- 14b. Block Diagram of DHC-6 RQAS - Lateral Mode
15. Block Diagram of Longitudinal CAS with Baseline and Filtered RIMS (F-5)
16. PSD Response of Basic Aircraft and Baseline RIMS (F-5)
17. PSD Response of Baseline and Filtered RIMS (F-5)
18. Block Diagram of RIMS with CMI (F-5)
19. C^* Response for Basic F-5, with RIMS, and with RIMS/CMI
20. SSSAS Test Aircraft
21. Basic Longitudinal RQAS (GPAS)
22. PSD Response for RQAS I
23. PSD Response for RQAS II
- 24a. Lateral RQAS Block Diagram
- 24b. PSD Response for Lateral RQAS
25. RQAS Design and Evaluation Procedure
26. The Ride Quality System

PRECEDING PAGE BLANK NOT FILMED

27. Schematic for Determining Passenger Satisfaction with Ride
28. Turbulence Exceedence Probability
29. Example of a 1-Cos Gust
30. Magnitude of Discrete Gusts
31. Intensity for Clear Air Turbulence
32. Family of Equiprobable Ramp Gusts
33. Relationship Between PSD and Reference Intensity
34. Percentage of Passengers Satisfied as a Function of RQI

LIST OF ABBREVIATIONS AND SYMBOLS

ABBREVIATIONS

AR	Aspect Ratio
CAS	Control Augmentation System
CMI	Command Mode Interconnect
CPU	Central Processor Unit
CSMP	Continuous Systems Modeling Program
FPS	Feet Per Second
FRL-KU	Flight Research Laboratory - University of Kansas
GLA	Gust Load alleviation
IG	Isolated Gust
GPAS	General Purpose Airborne Simulator
LAFS	Large Amplitude Flight Simulator
MLC	Maneuvering Load Control
NACA	National Advisory Committee for Aeronautics
NASA	National Aeronautics and Space Administration
PAX	Passengers
PSD	Power Spectral Density
RAE	Royal Aircraft Establishment
RIMS	Ride Improvement Mode System
RMS	Root Mean Square
RQ	Ride Quality
RQAS	Ride Quality Augmentation System
RQI	Ride Quality Index
RSS	Reduced Static Stability
SDG	Statistical Discrete Gust
SSSAS	Separate Surface Stability Augmentation System

SST Supersonic Transport
STOL Short Take-Off and Landing
TE Trailing Edge
TIFS USAF Total In-flight Simulator
T/O Take-Off
USAF United States Air Force

SYMBOLS

a_y Acceleration in Lateral Direction
 a_z Acceleration in Vertical Direction
 \bar{a}_x RMS Linear Accelerations in the Longitudinal Direction
 \bar{a}_y RMS Linear Accelerations in the Transverse Direction
 \bar{a}_z RMS Linear Accelerations in the Vertical Direction
C Ride Comfort Index
C(5) Comfort Rating on a 5-point Scale
C(7) Comfort Rating on a 7-point Scale
 C_E Comfort Rating on a 7-point Scale for a Given Ride Situation
 C_h Comfort Rating on a 7-point Scale for Rate of Change in Altitude, m/min
 $C_{L\alpha}$ Aircraft Lift Curve Slope, rad^{-1}
 C_{mot} Comfort Rating on a 7-point Scale for Motion
 C_{no} Comfort Rating on a 7-point Scale for Noise
 C_T Comfort Rating on a 7-point Scale for Temperature, °C
 $C_{Y\beta}$ Aircraft Side Force Curve Slope, rad^{-1}
dB(A) A-weighted Noise Level, dB
E Event (given ride situation)
g Acceleration of gravity, ft/sec^2
h Altitude (in meters where indicated, otherwise in feet)

\dot{h}	Rate of Change in Altitude, m/min
H	Gradient Distance, ft.
K	Gain Constant
K_1	Motion Sensitivity Coefficient
L	Scale Length, ft.
L_v	Scale of Turbulence for Y Gust, ft.
L_w	Scale of Turbulence for Z Gust, ft.
M	Mach Number
n_α	Load-factor Slope for Angle of Attack
n_β	Load-factor Slope for Sideslip Angle
n	Number of Events
n	Number of Passengers
n_z	Load Factor in the Z Direction
\bar{p}	RMS Roll Rate
$\dot{\bar{p}}$	RMS Roll Accelerations
q	Aircraft Angular Velocity in Pitch, rad/sec
\bar{q}	RMS Pitch Rate
\bar{q}	Dynamic pressure, lbs/ft ²
$\dot{\bar{q}}$	RMS Pitch Acceleration
r	Aircraft Angular Velocity in Yaw, rad/sec
r	Pearson Correlation Coefficient
\bar{r}	RMS Yaw Rate
$\dot{\bar{r}}$	RMS Yaw Acceleration
s	Laplace variable, sec ⁻¹
S	Wing Area, ft ²
S_1	RMS Linear Accelerations or RMS Angular Accelerations
\bar{S}_1	The Effective Stimulus

\bar{S}_{\max}	Maximum Value of \bar{S}_i
S_{T_i}	Threshold to Random Linear Accelerations or Random Angular Velocities
T	Temperature, °C
u_1	Forward Velocity (along X), FPS
v	True Air Speed, FPS
v_g	Gust Velocity in the Y Direction, FPS
W	Aircraft Weight, lbs.
w_g	Gust Velocity in the Z Direction, FPS
W/S	Wing Loading
x	Distance, ft.

GREEK SYMBOLS

α	Angle of Attack
α_g	Gust Perturbation
β	Sideslip Angle
β_g	Gust Perturbation
δ_A	Aileron Angle, deg, rad
δ_e	Elevator Angle, deg, rad
δ_f	Flap Angle, deg, rad
δ_r	Rudder Angle, deg, rad
δ_{sfg}	Side Force Generator Angle, deg, rad
δ_T	Kroneker Delta for Temperature
$\delta_{\dot{h}}$	Kroneker Delta for Rate of Change in Altitude
Σ	Summation Operator
$\bar{\sigma}$	Reference Intensity
σ_1	True RMS Intensity

σ_{g_v}, σ_v	Gust Intensity - Lateral Direction
σ_{g_w}, σ_w	Gust Intensity - Vertical Direction
ϕ_{v_g}	PSD of Y Gust as a Function of the Spatial Frequency
ϕ_{w_g}	PSD of Z Gust as a Function of the Spatial Frequency
ϕ_v	PSD of Y Gust as a Function of the Temporal Frequency
ϕ_w	PSD of Z Gust as a Function of the Temporal Frequency
ρ	Air Density, slug/ft ³
Ω	Spatial Frequency
ω	Temporal Frequency
$\bar{\omega}_1$	RMS Angular Velocity
θ	Pitch attitude angle, rad

1.0 INTRODUCTION

The commuter airline industry has expanded rapidly in both numbers of carriers and numbers of flights over the past several years, due principally to the federal government deregulation of the major carriers in 1978. Following deregulation, the major airlines showed an understandable preference for continuing the longer, more profitable routes, while divesting themselves of the shorter, less populated routes previously forced on them by the Civil Aeronautics Board. The commuter airlines have been picking up most of the routes dropped. For example, in 1980 the number of commuter passengers increased by 6% while the number of major airline passengers decreased. The number of commuter passengers increased by 13% in 1981 and by an estimated 18% for the current year. The end result has been that more and more of the general public are now exposed to rides on the smaller and generally less sophisticated commuter aircraft.

To accommodate this increased market there has been an increased interest in small (15-50 passenger), short-haul, propeller driven aircraft. This has led to a resurgence in research and development aimed at producing improved commuter aircraft [1]. Technological advances in aerodynamic and powerplant efficiencies, propeller design, and noise abatement are being examined specifically for application to commuter aircraft. New designs incorporating advances in structures, aerodynamics, engines, and propellers are currently being created by the major domestic and foreign airframe and engine manufacturers and leading educational institutions. In addition, human factors engineering has been done to improve the seating comfort, reduce the internal noise levels, and increase the carry-on luggage space - three commonly voiced criticisms of the commuter aircraft. In summary, effort is being expended toward making the commuter aircraft as efficient and as comfortable as the major airliners. However, one important area that has received little recent attention is ride quality or ride smoothness. Ride quality is a function of the aircraft aerodynamics, control system, and mission profile. The commuter aircraft, because of its characteristic aerodynamic design and typical mission profile, is a good candidate for an active Ride Quality Augmentation System (RQAS). This is particularly true because more and more new commuter passengers have had flight experience only on large aircraft, and are thus uncomfortable with the significantly rougher ride of the commuter. Ride

smoothing systems are not new, with research having been done over the past 30 years. However, applications to date have been limited to high speed, low-flying military aircraft such as the B-52, B-1, F-5 and the F-111.

To investigate the potential use of RQAS on commuter aircraft, the Flight Research Laboratory of the University of Kansas Center for Research, Inc. (FRL-KU) under NASA sponsorship undertook a study to examine the state-of-the-art of RQAS, and to determine the applicability and technical feasibility of applying existing technology to the design of a RQAS for current and future commuter class aircraft.

The remainder of this report will include:

1. A brief discussion of the basic concepts and descriptions of RQAS.
2. A review of past work including generic analytical studies, aircraft specific designs, and flight tested systems.
3. A review of advancements in related technical areas.
4. And finally a recommended program for the continuation of RQAS research for commuter aircraft.

This section lays the foundation for the review of the ride quality systems and includes problem definition, a description of the basic RQAS approaches, and a brief discussion of the evaluation procedure. The basic system is shown in block diagram form in Figure 1. In terms of the basic system block diagram, the problem definition is associated with the turbulence and aircraft models, the various RQAS approaches are included in the RQAS model, and the evaluation procedure includes the whole system.

2.1 PROBLEM DEFINITION

The fundamental objective of this study was to determine the technical feasibility of improving the ride of commuter class aircraft by use of active controls. A poor ride is characterized as one with enough motion perturbations of significant magnitude to be unacceptable to the passengers. These motion perturbations, or bumps, are related primarily to the vertical and lateral accelerations of the aircraft. For an unaugmented aircraft these accelerations are a function of wing loading (W/S), lift due to angle of attack ($C_{L\alpha}$) for vertical and side force due to sideslip angle ($C_{Y\beta}$) for lateral motions, and altitude. To a first level approximation this relationship is shown by the equations below:

$$a_y = \frac{\rho u_1}{2} [C_{Y\beta}] \left[\frac{1}{W/S}\right] [\sigma_{g_V}] \quad (1)$$

$$a_z = \frac{\rho u_1}{2} [C_{L\alpha}] \left[\frac{1}{W/S}\right] [\sigma_{g_W}]$$

For a given level of gust (σ_g - basically a function of altitude), a lower wing loading or higher lift or sideforce slope will result in a rougher ride. As shown in Figure 2, a reduction in the $[C_{L\alpha}/W/S]$ ratio by a factor of 2.1 has caused a full order of magnitude reduction in the number of 1/2 "g" bumps experienced. From the earliest studies dating back to the 1930's, up through the most current work in the mid 1970's, low wing loading has been considered the primary design characteristic contributing to poor ride quality.

Commuter aircraft normally have low wing loading, and high lift curve slopes due to their minimum field length T/O requirements. They also are exposed to high intensity gusts due to their low cruise altitudes. Table 1, Current and Future Commuter Characteristics, shows the major differences in wing loading and cruise altitudes typical between the commuter and the Boeing 700 series of commercial airliners. The cruise altitude is a major factor because gust intensity increases as altitude decreases. A third characteristic difference occurs in the lift curve slope. The normally higher aspect ratio and unswept wing of the commuter generally leads to a higher lift curve slope. The swept wings of the larger airliners, although not designed for this reason, improve ride quality by decreasing the lift curve slope, while the straight wings of the typical commuter do nothing to alleviate this problem. Finally, the commuter ride is even further impacted by the fact that the commuters are basically rigid aircraft. Very little of the turbulence is absorbed by the flexing of the structure, thus transmitting the full effect to the passengers. In summation, the commuter's low wing loading, high lift curve slope, low cruise altitude, and rigidity all contribute to a ride quality for the commuter which is inferior to the large airliners. A comparison of an M99 (a modified Beech 99) and a Boeing 737 is shown in Figure 3. The 737 satisfies 85% of the passengers up to a high gust level (low probability of exceedance) while the M99 satisfies a smaller percentage even at relatively low gust levels (high probability of exceedance).

Based on the characteristics cited above, commuter aircraft are excellent candidates for a RQAS. The larger airliners have not required RQAS because their high wing loading, swept wings, and high cruise altitudes provide an already smooth ride. Private aircraft, although very definite candidates for ride smoothing, simply can not justify the cost. Three factors make it important to reexamine the feasibility of using RQAS now. First, prior to deregulation, only limited numbers of passengers with typically high levels of flying experience rode the commuters regularly. This type of passenger didn't expect the commuter to provide a very smooth ride. Deregulation changed this so that now more of the general public are flying on commuters, and they are more apt to expect an airliner type of ride quality. To make their service attractive to this larger class of passengers, the commuter aircraft can now

ORIGINAL PAGE IS
OF POOR QUALITY

Table 1. Current and Future Commuter Characteristics

Aircraft	Cruise		Number of Pass.	Max T/O Weight (lb)	W/S	AR
	Vel (mph)	Alt (ft)				
Aerospatiale (Nord)						
262	233		26-29	23369	39.5	8.7
ATR-42	319	20000	49	32450	58.5	12.4
Ahrens AR404	195	5000	30	17500	41.5	10.3
Antonov An-26	266	19700	39 (Mil)	52950	65.6	11.4
Beech Aircraft Co.						
C-99	288	10000	15	11300	40.4	7.6
1900	304	10000	19	15245	50.3	9.8
British Aerospace						
Jetstream 31	304	15000	18-19	14100	52.3	12.0
CASA C-212-200	240	10000	26	16093	37.4	9.0
DeHavilland						
DHC-6 (Twin Otter)	210	10000	13-18	12500	29.8	10.1
DHC-7 (Dash 7)	266	10000	50	44000	51.2	10.1
DHC-8 (Dash 8)	300		32			
Dornier Commuter LTA	250	9850	24	15102	41.4	9.4
Embraer EMB-120	291	20000	30	21164	51.7	10.3
Fokker F.27-200	298	20000	52	44996	59.7	12.0
F.27-500	300	20000	60	45000	59.7	12.0
F.27-600	300	20000	44	45000	59.7	12.0
Gulfstream American G1-C	291	25000	37	36000	59.0	10.1
Saab-Fairchild SF-340	313	15000	34	25000	55.5	11.0
Shorts						
330	220	10000	30	22600	49.9	12.3
360	243	10000	36	25700	56.7	12.3
Swearingen Metro II	294	10000	20	12500	45.0	7.7
Cessna 402B	240		6	6300	32.2	
Boeing						
727-200	614	25000	189	209500	127.0	7.1
737-200	568	25000	130	117000	119.4	8.8
757-200	494	29000	196	230000	115.3	7.8

justify the added cost of an economical RQAS. The second factor is the recent advances in technology particularly optimal control and digital hardware. These advances offer the possibility of a RQAS for commuters that is both technically and economically feasible. This is, therefore, an opportune time to reexamine RQAS. Finally, the next generation commuter is still in the design stage, and a design could now be easily modified to include a RQAS.

2.2 RIDE QUALITY AUGMENTATION SYSTEM CONCEPTS

Fundamental to any discussion or research of RQAS is a basic understanding of what a RQAS is and what it does. The RQAS, as the acronym implies, smoothes the aircraft ride by using active controls to remove the perturbation motions introduced into the aircraft by the natural turbulence or gusts. The RQAS consists of three subsystems: (1) some type of sensor(s); (2) a control algorithm/law; and (3) some surface actuation system to apply the desired corrective forces to the aircraft (Figure 4).

The design of a RQAS is dictated by the variable used to define the disturbance and the mechanism used to apply corrective forces and moments to the aircraft. Two basic approaches have been utilized for sensing the disturbance (Figure 5). The first method, referred to as an open loop system, uses a vane mounted on a boom on the forward part of the fuselage. This vane senses the gust induced change in angle of attack before the gust hits the wing. The second method to quantify the disturbance, referred to as a closed loop system, senses a vehicle motion variable, e.g., acceleration, rather than an external variable such as the gust itself.

No matter how the perturbation is sensed, the RQAS will then use corrective forces and moments to attempt to control the ride. This is done through either attitude control (elevator for vertical and rudder for lateral), through direct force control (direct lift/sideforce generators), or a combination of both. Finally, whether attitude or direct force control is used, the control surfaces can be either existing surfaces (elevator, aileron, flap, rudder), or separate dedicated surfaces (split elevator/aileron/flap/rudder, separate side force generator).

The control algorithm operates as an interface between the sensing system and the actuation system. It is of course a function of the sensing and implementation decisions, and it provides the desired dynamic response of the

total system. The control algorithm can be designed for an analog or digital implementation, or for a pure mechanical system.

In summary, the decisions on the type of sensor, the control algorithm development, and the attitude/direct force control executed by either existing primary surfaces or separate dedicated surfaces are all interrelated. Thus, the selection of the components of a RQAS must be made on the basis of an entire system. The variety of possibilities are illustrated later when past designs are reviewed.

2.3 ANALYTICAL SYSTEM EVALUATION APPROACH

A standard evaluation method must be applied to all RQAS considered in order to insure a fair comparison of all systems. This standard method must include standard inputs, and a standard quantitative way of evaluating the effect of the RQAS. Therefore, the first step in this project was to examine the inputs and output performance measures for use in RQAS design. Appendix A contains the detailed discussion of ride technology, including the various types of inputs and output performance measures. The following provides a summary of that information.

The forcing function generating the requirement for a RQAS is the atmospheric turbulence. Various mathematical models have been used in the analytical design of RQAS, each having specific advantages and disadvantages. The various turbulence models considered for analytical use were: the single discrete 1-cos gust; the Von Karman power spectral density (PSD) model; the Dyrden PSD model; and the statistical discrete gust (SDG) model. The 1-cos gust is most applicable for analysis of extreme cases, while the PSD models are more appropriate for an analysis over a significant range of inputs. The SDG method has been used by the British in preliminary work, but has yet not been used in actual design efforts.

In addition to defining a forcing function, a performance measure to compare RQAS is required. This measure has typically been some measurement of the attenuation of the unwanted perturbation motion at specific flight conditions and frequencies. In the early work, prior to the 1970's, there was no quantitative measure of "ride comfort," and in fact this term had different meanings to the different researchers. In the 1970's a great deal of research was directed toward generating a quantitative Ride Quality Index (RQI) which would correlate well with the qualitative passenger ratings. This research

was directed at identifying the key motion variables and their relative importance. A detailed review is included in Appendix A. This resulting RQI would be used to compare unaugmented aircraft to augmented aircraft, and various RQAS designs to each other.

3.0 REVIEW OF RIDE QUALITY AUGMENTATION RESEARCH AND RELATED TECHNOLOGIES

To determine the current state-of-the-art of ride improvement systems, a computerized and manual literature search, from 1951 to the present, was done using the following topics/key words: ride quality for general aviation aircraft, ride quality, gust alleviators for general aviation aircraft, gust alleviators, ride comfort, ride quality, active controls, electric airplanes, and turbulence models. The total list of all documents reviewed during this literature search is included as Appendix B. Other sources of information were discussions with prominent researchers in the fields of ride comfort quantification, RQAS, and other related areas. Based upon this body of information, the research review was divided into three parts: RQAS research prior to 1970; RQAS design subsequent to 1970; and related technologies. The RQAS after 1970 were further subdivided into generic studies, specific aircraft designs, and flight tested systems.

3.1 RQAS PRIOR TO 1970

Efforts to perform ride smoothing on aircraft began as early as the 1930's [2, 3]. Some innovative and complex systems were tried during the early years. One of the earliest and most unusual efforts consisted of an aircraft with wings mounted to the fuselage by skewed hinges and pneumatic struts. The pneumatic struts acted much the same as the shock absorber on an automobile, that is, when unbalanced forces were encountered the pneumatic struts would permit the wing to skew, thus changing the angle of attack. The problem with this concept was that the basic lateral maneuvering was limited to very gradual movements in order to prevent the wings from skewing in opposition to the desired rolling moment. Another of the early efforts was a very complex system designed in about 1938, but not test flown until the late 1950's and early 1960's. This system used a very complicated system of separate surfaces controlled by cables and other mechanical means to relieve the unbalanced forces caused by the turbulent gusts. This particular system controlled both the vertical and lateral modes, and even with modern technology would require a multitude of sensors and servomechanisms to implement. Its severe complexity caused this system to be discounted for any possible operational use after a few research/demonstration flights.

The British designed and conducted test flights of a RQAS on the Lancaster bomber in the early 1950's. This system consisted of an open loop angle of attack vane sensor that drove symmetric aileron deflections for vertical ride smoothing only. The system exhibited amplified, rather than attenuated, vertical motion in early test flights and so was abandoned. After a later detailed analytical review, the failure of this system was blamed on incomplete analysis of the system's pitching moment due to aileron deflection. In their early efforts, and to a certain extent in their current efforts, the British and other Europeans tend to favor the vane sensor open loop systems.

Numerous efforts by the NACA/NASA and private companies were carried out in the U.S. between 1950-1961. The most significant of these was for a vertical ride smoothing system initiated in 1951 [4]. This RQAS consisted of a vane sensor on a boom with direct lift control through flap deflection and pitch control through the elevator. This preliminary analytical study was followed by a flight test on a C-45. The C-45 was modified to provide separate dedicated RQAS control surfaces (Figure 6). The flight test was performed at a single flight condition and resulted in a 40-50% attenuation of vertical acceleration at specific frequencies. Pilot opinion of the handling qualities remained favorable. Further flight tests added slaved ailerons to the direct lift flaps and a negative feedback in the flap command loop to permit trim changes. An attenuation of 60% in the short period frequency range was attained. A closed loop system with a C-G mounted accelerometer was also tested, but with much less spectacular results.

From 1961 to the early 1970's, very little work on RQAS was done in the U.S. The work that was done by other countries was generally analytic [3]. This relative lack of activity by NASA and U.S. companies during that period is accounted for by the lack of a valid requirement for the application of a RQAS.

3.2 RESEARCH FROM 1970 TO THE PRESENT

RQAS research has been active during this period for two applications: STOL aircraft and military aircraft. The potential use of STOL aircraft for intracity transportation caused an active interest in the early 1970's. STOL aircraft had an even more dramatic need for RQAS's than modern commuter class aircraft due to their very low wing loading. When the STOL aircraft did not

capture the large share of the intracity market as expected in the 70's, the RQAS research was again deemphasized.

Throughout this period the research into RQAS or gust alleviation system has been of active interest to the military both in the U.S. and abroad. The high speed low level penetration mission often flown by the military requires an active augmentation system to alleviate pilot fatigue and to improve the weapon platform capability. However, the primary focus of this subsection will be a review of RQAS research efforts with results applicable to commuter type aircraft.

3.2.1 Analytic Studies-Parametric

Three parametric designs have been selected for discussion in this subsection because they represent three different approaches to the design and implementation of a RQAS. The first study was done by Boeing-Wichita and was generated for an advanced STOL configuration [5]. The second was done by the Royal Aircraft Establishment and is concerned with a fighter-type aircraft [6, 7]. The third study was done by Lockheed-CA and was one of a family of studies done for NASA [8].

The Boeing study dealt with a jet-powered STOL transport larger than the normal commuter. The aircraft was configured for a wing loading of 46 psf, 130 passengers, 750 N.M. range, a 2000 ft. field length, and a cruise mach of 0.8. This configuration used double slotted trailing edge (TE) flaps. The RQAS used the aft portion of the TE flap for longitudinal ride smoothing and the rudder for lateral ride smoothing. Linear, small perturbation, six degree-of-freedom rigid body equations of motion were used for the aircraft model in the analysis. Random turbulence using the von Karman spectrum and discrete 1-cos gusts were used as inputs to the aircraft model. The turbulence probability of exceedance of .001 was used, corresponding to gust intensities ranging from 9.8 fps during approach to 5.7 fps during cruise. Acceptable levels of vertical and lateral accelerations were set at .11g's and .055g's respectively. The control signals were based on the feedback of only vertical and lateral accelerations sensed in the passenger compartment. The plots of vertical and lateral acceleration for cruise, descent, and landing are shown in Figures 7, 8 and 9. The RQAS was shown not to degrade the handling qualities of the aircraft (Fig. 10) during cruise and descent. The RQAS reduced the accelerations to within acceptable limits for the cruise and

descent modes. However, the RQAS could not be used during landing because of a degradation in the handling qualities. Some of the areas for future research specified were the need for gain scheduling, the accuracy of the rigid aircraft assumption, and non-linearities introduced in severe turbulence. The overall conclusion was that a STOL transport with the stated characteristics and a RQAS could provide satisfactory ride quality and competitive high-speed performance, although degradation of the handling qualities required further examination.

The recent British efforts in the ride smoothing area have been parametric studies directed toward fighter-type aircraft [6, 7]. Their application differs from a commuter RQAS in that they are more concerned in smoothing the ride in terms of a weapons platform. This requires that pitching motion in addition to accelerations be reduced. Reference 6 deals with only the vertical motion and proposed the use of direct lift flaps or ganged ailerons for implementation. This work examined the use of a closed loop acceleration feedback, an open loop angle of attack signal, and a combination of both. Both the Dryden and von Karman PSD and a statistical discrete gust method were used. The initial work concluded that active ride smoothing could not be done very well, because when the magnitude of the accelerations was reduced, the number of acceleration peaks (bumps) increased (at lower magnitude levels). This was in contrast to the decrease in both magnitude and number of peaks caused by an increase in wing loading or a decrease in lift curve slope (Fig. 11).

In their later work [7], the British examined the importance of the frequency content of the gust response by including a crew sensitivity factor consisting of the human frequency response and a crew station load factor to better evaluate the gust effect on the crew (Fig. 12). This design used both an unspecified device for direct lift control and the elevator for pitch control. A combination of gust vane and accelerometers were used as sensors. The British again pointed out the increase in sign reversal in the acceleration response, a phenomenon that they refer to as a "cobblestone ride." It was also hypothesized that in a flexible aircraft, this characteristic may indeed be enhanced. Finally, a concern was presented regarding the conflict between handling qualities and ride smoothing systems. In summation, the British have found that although the magnitudes of the gusts can be reduced using active control, an increase in the number of "bumps"

occurs and that care must be used in implementing a RQAS which may prove a detriment to handling qualities.

The third parametric study was done by Lockheed-CA under NASA sponsorship [8]. The configuration used was for 30-50 passengers, a cruise of mach .5, and reversible flight controls. The RQAS design for this study was based on a three-degree-of-freedom longitudinal model and utilized the Dryden spectrum for the system input. The control signal was implemented through trailing edge flaps, spoilers, and elevators. Predictions were made that this system could give this advanced short haul transport ride characteristics similar to the larger commercial aircraft. However, no quantitative results were documented.

3.2.2 Analytic Studies - Specific Aircraft

Five aircraft specific RQAS designs have been selected for review and comparison. This broad range of systems was selected in order to get a representative cross section of all possible sensing and implementation schemes in order to better evaluate their relative strengths and weaknesses. These designs vary in application from a light personal aircraft (Cessna 172) to an SST design. These RQAS's represent applications to linear and non-linear systems at flight speeds from very slow to supersonic, with control systems ranging from simple reversible to complex active irreversible, and applied to both small rigid and large elastic aircraft. These five designs will be reviewed in chronological order of their application.

The first design in this area was applied to the SST [9] and is the most technologically advanced. This design was for a digital implementation on a flexible aircraft that must compromise between handling qualities, stability augmentation, ride quality, and modal suppression. The RQAS was limited to the vertical mode and used two body mounted accelerometers. A digital stochastic, model following control law was implemented through only elevator control. Through appropriate choices of the quadratic weighting matrices for the controls and the state variables, the aircraft responses were tailored to reflect emphasis on the desired goal (i.e. ride smoothing, modal suppression, etc.). The conclusion was that digital modern control techniques can design a combined stability, control, and ride smoothing system for a relatively complex aircraft model.

8
Y

From the most complex design, the next to be reviewed is the simplest. This design was made for the Cessna 172 [10] and was a purely mechanical system that required no electromechanical or hydraulic sensors, actuators, or control system. This RQAS was for the vertical mode only and was designed to use direct lift control through mechanical linkage to an auxiliary sensor wing/vane. The basic concept was very similar to the pivoting wing concept of the 1930's, except in this case the main wing did not move but rather the auxiliary wing moved under nonsteady loads. The auxiliary wing was connected to the flaps on the main wing through mechanical linkage. When a gust load hit the sensor wing, it deflected the flaps on the main wing so as to keep the non-equilibrium load due to the gust from causing unacceptable accelerations. The system was designed but never implemented due to the large weight penalty incurred. This system had the advantage that it was purely mechanical. However, this system would have been very limited in application because of the inherent inflexibility of a mechanical system.

The next design was created by Boeing-Wichita under NASA contract for the DeHavilland DHC-6 Twin Otter [11, 12]. This design controlled both vertical and lateral ride smoothing through the use of direct lift generators and the rudder, respectively (Fig. 13, 14). This system applied separate surfaces to implement the RQAS commands. The separate surfaces included the use of irreversible flight controls and electromechanical servos for the dedicated separate surfaces, and the reduced requirement for redundancy and reliability in the RQAS. This system was designed to use acceleration feedback to dedicated control surfaces and was based on linear, rigid, six degree-of-freedom equations of motion. The original program called for a joint U.S.-Canadian aircraft modification and flight test program. However, due to decreased emphasis on STOL aircraft, this program was not continued past the analysis stage.

The fourth design was made by the Northrop Corporation for the F-5 [13], a small highly maneuverable fighter used in a ground attack mode. This mission requires low level high speed flight, and thus the interest in a ride smoothing system. The Ride Improvement Mode System (RIMS), as Northrop called their RQAS, was designed to use the existing TE flap and actuator system for direct lift control to provide only vertical ride smoothing. A non-linear, longitudinal, three degree-of-freedom Continuous System Modeling Program (CSMP) was used to model the system. The worst possible flight condition,

M=.9 at 500 ft, was chosen for the design. The Dyrden spectrum was used as the turbulence model, and a probability of exceedence of .01 defined the gust intensity. Although the F-5 is very different from a commuter aircraft, its wing loading is 57.5 psf. This similarity in wing loading makes the results of this study applicable to commuter aircraft.

A baseline RIMS was designed and implemented on the Northrop Corporation's Large Amplitude Flight Simulator (LAFS). A block diagram for the baseline and a lag/lead RIMS is shown in Figure 15. RMS accelerations were attenuated by 40-50% when using the baseline RIMS (Fig. 16). The baseline RIMS left a large peak between 1-2 Hz, and a structural peak between 10-15 Hz, both of which caused concerns. A lag/lead compensator was then added to tailor the response to reduce these peaks, the result of which is shown in Figure 17. However, both RIMS versions caused drastic degradation in handling. Therefore, a Command Model Interconnect (CMI) (Fig. 18) had to be added to correct the handling qualities problem. The CMI fed the pilot's stick command forward through a lead/lag filter to the stabilator to compensate for the resistance encountered from the RIMS. This modification had virtually no impact on the performance of the RIMS but improved the handling qualities over the standard F-5 CAS (Fig. 19). The conclusions of this study were that improved ride qualities were possible with relatively simple control law implementations, and that the degradation of handling qualities could be avoided with judicious selection of control loops and interconnects.

The last design to be reviewed in this section was made by Dornier for application on a Do 28-TNT, a commuter class aircraft [14]. The design was for vertical smoothing only and was based on linear two degree-of-freedom equations of motion. This design commanded direct lift controls based upon a perturbation signal from a combination of vane angle of attack and acceleration feedback. This open and closed loop combination was used because the open loop method was too sensitive to error in the aircraft parameters, and the closed loop method caused problems with the frequencies near the structural modes. Pitch rate control was not used in order to retain adequate handling qualities. The comfort criteria chosen was based upon a linear combination of all the linear and angular motion variables. Although flight tests were programmed for the early 1980's nothing has been found that contains any information on whether or not flight tests were ever done.

3.2.3 Flight Tested Systems

Three systems either designed specifically for ride smoothing or very closely related to ride smoothing have been flight tested. The first of these was done by the FRL-KU under NASA sponsorship. This program was directed specifically at the use of separate control surfaces for stability augmentation. The second program was by the University of Virginia under NASA sponsorship, and was a RQAS demonstration program on the General Purpose Airborne Simulator (GPAS). The third program to be discussed is presently in commercial service on the L-1011. It also did not deal specifically with a RQAS, but rather with the very closely related topics of Gust Load Alleviation (GLA) and Maneuvering Load Control (MLC).

The FRL-KU Separate Surfaces Stability Augmentation System (SSSAS) program involved the design, implementation, and flight test of a SAS using small separate surfaces on the Beech 99 [15, 16, 17]. The basic program goal was to demonstrate the use of these separate non-primary control surfaces for the SAS functions. A SAS of this type would greatly reduce the requirements for reliability and/or redundancy. The separate surfaces for this program were generated by splitting the existing control surfaces of the Beech 99 (Fig. 20). This was feasible on this particular aircraft because it had an excess of control power available. Standard techniques were used for control surfaces sizing, control derivative calculation, surface balancing, and flutter analysis. Classical control techniques were used to develop the analog control laws for the test conditions. The system was tested on both a ground based hardware simulator and flight simulator prior to flight test. The flight test proved the feasibility of the separate control surfaces concept. Although this program specifically demonstrated a separate surface SAS, these same separate surfaces could easily be used for the RQAS function by the proper adaptation of the control algorithm.

The second RQAS design was test flown on a research aircraft, the NASA GPAS (a modified Lockheed Jetstar C-140 light utility transport). This aircraft already had the necessary direct force generators with existing actuators with adequate responses. The design of the RQAS was done by the University of Virginia under NASA sponsorship [3]. This Ride Smoothing System (RSS) design controlled both the vertical and lateral motions through a closed loop system. This RSS used a combination of acceleration feedback and pitch attitude feedback in a pitch damper loop. The analytical calculations were

based on a rigid, linear, small perturbation, six degree-of-freedom model with negligible engine gyroscopics. The Dryden spectrum was used for the turbulence input PSD, because of its factorability, and the gust intensity level was defined by a probability of exceedence of .01. The study utilized classical root locus and bode design techniques. The principal design problem was selecting the correct combinations of gains and filters for each of the feedback loops (Fig. 21). Two longitudinal RSS designs were selected for use in simulation and flight test. Two separate lateral RSS's were designed, one using the direct sideforce generator and one using only the rudder. The rudder implemented lateral RSS was found to be deficient and only the direct sideforce PSS was used for simulation and flight test. The PSD response plots for the two longitudinal designs are shown in Figures 22 and 23, and the lateral RSS and the resulting PSD plot are shown in Figure 24. The ride comfort index shown below, using only vertical and lateral RMS accelerations, was used to evaluate performance.

$$C = 2 + 11.9 \bar{a}_z + 7.6 \bar{a}_y$$

An analytical evaluation of the index showed about 1.0 point reduction from the basic aircraft value of 3.6. This is equivalent to increasing the percentage of satisfied passengers from 67% to 85%.

This system was also modeled on a fixed base simulator to attempt to get some pilot opinion of the modified handling qualities. The results of the ground based simulation indicated a slight improvement of the handling qualities with the RSS turned on. The next step was then to flight test the system on the GPAS. The RSS was implemented on the onboard analog computer and the existing sensors and control surfaces were connected appropriately. Due to a non-RSS failure on the GPAS, only two flight tests were conducted. Based on the limited amount of data available, the preliminary conclusion was drawn that the theoretical and experimental data agreed reasonably well. No qualitative data from passengers was taken, so the predicted increase of satisfied passengers from 67% to 85% could not be substantiated by actual passenger experience. Three suggestions for follow-on work were (1) to try optimal control, (2) to investigate more thoroughly the requirement for gain scheduling, and (3) to perform more flight tests.

The final system implemented in an existing aircraft was done by Lockheed to the L-1011 [18]. This system is currently certified and in commercial service aboard some L-1011's. Although not designed as a RQAS (because the ride of the L-1011 does not require one), the Maneuver Load Control (MLC) and Gust Load Alleviation (GLA) systems have the same functional components as a RQAS, but perform a slightly different task. The objective of these systems is to keep the aircraft wings from bending either due to gusts (GLA) or during maneuvers (MLC). These systems were implemented on the L-1011 in order to extend the span without adding excessive structural weight. The extension of the span increases the aerodynamic efficiency and therefore the range. Both these systems used acceleration feedback and separate surface controls and operate under much the same principle as a RQAS. The experience gained from these systems relative to reliability and acceptance should prove beneficial to an attempt to certify a commuter RQAS.

3.3 RELATED TECHNOLOGIES

All but one of the RQAS research and designs reviewed in this study were designed utilizing classical control design techniques (Root Locus and Bode analysis) and analog implementation. These were the current state-of-the-art at that time. The fact that these RQAS were test flown demonstrated the technical feasibility of these systems. However RQAS were never used operationally principally due to the difficulty of providing adequate RQAS performance over the entire mission profile, and to problems in the degradation of handling qualities. The total mission performance problem could have been solved using gain scheduling, but gain scheduling is difficult to implement with analog systems. Similarly, the handling degradation problem was solvable using classical analog control design techniques, but as a separate problem for each different flight condition.

Just as the airline deregulation of 1978 provided an increased need for RQAS for commuter aircraft, the advancement in related technology has improved the overall feasibility of the RQAS in terms of performance, reliability and costs. In particular, advances in modern control theory, aircraft parameter identification, and digital hardware now provide improved technical and economic feasibility of RQAS for commuter aircraft.

Although modern control design techniques have existed since the early 1960's, only recently have these techniques been demonstrated in flight

tests. The advances in modern control theory are most evident in the application to spacecraft and military aircraft, but these techniques have also been applied to lighter aircraft. Flight test programs have demonstrated an optimally designed, full state feedback-gain scheduled autopilot on the CH-47 tandem rotor helicopter [19, 20], and a full state feedback fixed gain autopilot on the NAVION general aviation aircraft [21]. More recent research [22] has projected that the optimal control design procedure can be modified for controllers using less than full state feedback. The use of limited state feedback combines the advantages of the multi-input/multi-output structure of optimal control with the reduced sensor and/or observer requirements desirable for commuter implementation. The utility of the optimum design procedure is that by adjusting the state or control weighting matrices, the response can be tuned in any manner desirable. For example, a trade-off can be made between ride quality and handling qualities by appropriately weighting the acceleration and pitch attitude states. A trade-off can also be made between the state response and the control activity by appropriately weighting the state and the control variables.

Along with the increased use of modern control techniques, and partially motivated by the requirements associated with optimal control, the capability to more easily, quickly, and cheaply derive accurate aircraft models has been greatly improved. The FRL-KU has developed, under NASA sponsorship, a portable self-contained parameter identification package [23]. This package, with the associated computer programs, can provide accurate stability derivatives in a short time and for relatively low cost. The existence of tools such as this, which provide the accurate aircraft model necessary for optimal designs, has greatly enhanced the capability to apply optimal full or limited state feedback to designs of systems (such as RQAS) for commuter aircraft.

Accompanying the advances in optimal design technology are the advances in the digital hardware needed to implement these advanced designs. Knowledge of the rapid advances in microprocessor capabilities is wide spread. The exponential increase in the use of microcomputers in the laboratory, the office, and the home has given the development of new and more powerful microprocessors the impetus needed to really push the state-of-the-art. Capabilities have increased while costs have come down. For example, the Z-80 Central Processor Unit (CPU), since only 1980, has doubled the operating speed from 2 MHz to 4MHz, while reducing the cost by almost two-thirds. The reduction in

cost of memory and peripheral chips is just as dramatic. Accompanying the increased capability and decrease in cost is a marked improvement in the reliability and maintainability of digital equipment. The Collins Avionics Group of Rockwell International has turned toward digital radios and avionics because these components are easier to make, faster and easier to maintain, and are now better supported by ground crews properly trained in digital systems [24]. Digital subsystems in avionics and displays have already been integrated into commercial and commuter aircraft designs. Digital primary flight control systems are currently being developed by the USAF. The increased capabilities and reliability, along with reduced cost, offer increased potential for application on commuter aircraft systems such as the RQAS.

The advances in sensors and actuators, although not nearly as dramatic as the advances in digital technology, have produced lighter, more powerful, and more reliable components [25]. The emphasis on electromechanical servos has been due primarily to the desire to utilize the Reduced Static Stability (RSS) on fighter aircraft, such as used on the USAF F-16, to realize reduced drag penalties. However, the advances made could provide benefits to the design of a RQAS in terms of lower weight, increased power, and increased reliability and reduced cost.

4.0 DISCUSSION AND RECOMMENDATIONS

The most basic question in the area of RQAS is "Are RQAS needed for commuter aircraft today?" We submit that the answer to this question is very definitely yes. Prominent researchers felt that the answer to this question was yes as early as 1976, even prior to the deregulation of the major carriers. As stated in Ref [26], passenger ride comfort can have a significant influence in determining acceptance and use of various modes of air transportation. Therefore, as more and more of the general public fly on commuter class aircraft, making the ride feel as smooth and comfortable as the larger commercial aircraft must assume a higher and higher priority. As shown in Ref [27], even the advanced designs do not exhibit nearly as good a ride as the existing commercial airliners (Fig. 3). The same ride deficiency exists in the current commuters, but to even a greater degree.

The commuter has low wing loading, a high aspect ratio unswept wing. It also has more landings and take-Offs, and a lower cruise altitude, the total result of which is a relatively bumpy ride. The commuter is definitely a good candidate for a RQAS, and the technical feasibility has been demonstrated by the research already done. The problem then is to design and demonstrate not only the technical aspects of a RQAS, but also to demonstrate the economic feasibility. The remainder of this section discusses the research development required to accomplish these objectives, and proposes a preliminary RQAS for detailed design and development.

4.1 RIDE QUALITY RESEARCH AND DEVELOPMENT

Having established both the need for a RQAS for commuter aircraft and the high probability of the technical feasibility of such a system, the question remains as to what else must be done before RQAS will be incorporated in future commuter designs. There are three ride quality research areas which warrant further investigation either prior to, or concurrent with, the detailed design of the preliminary RQAS. These three areas are (1) fundamental research, (2) applied research, and (3) research toward development of an analysis, design and evaluation procedure.

4.1.1 Fundamental Research

Two basic research areas which require additional investigation are separate surface controls and the RQI. Basic questions regarding the use of separate surfaces include: (1) what effect will the unsteady aerodynamics caused by the constant motion of the controls have, (2) what design procedure should be used for separate surface location and sizing, and (3) what type of actuator power reliability and redundancy requirements should separate surface have. In terms of the RQI, an extensive amount of literature has concluded that, if RMS variables are used in the model only, vertical and lateral acceleration are needed to provide good correlation between the qualitative and quantitative subjective transfer function. However, a basic question still exists as to whether a straight RMS variable should be used in the RQI equation, or rather should some frequency weighting be applied to the RMS variable as the British did with Human Frequency Response plot shown in Figure 12. If some frequency weighting is applied to the RMS variables, then the correlation between the qualitative and quantitative subjective transfer function must also be reexamined to determine if attitudes and rates must be included in the RQI expression. One further aspect of the RQI that needs to be examined further is the different effects that up-and-down motion have on the passengers. Perhaps some type of "average" acceleration biased in either the up-or-down direction would provide better correlation than an RMS value. These basic research questions are independent of any RQAS design efforts.

4.1.2 Applied Research

Two concerns associated with RQAS in general are the requirement for gain scheduling and the amount of RQAS and structural interaction. The need for gain scheduling was mentioned in several of the efforts reviewed, but no quantitative evidence supporting or denying this concern has been found. The fact that stability control derivatives and gust intensities vary significantly over a typical commuter profile suggests the need for gain scheduling, but this requirement is thus far unsubstantiated. Another research area applicable to RQAS in general is the effect, both in the areas of strength and fatigue, which the RQAS will have on the structure. More information on component and structural fatigue and the tradeoff between RQAS performance and structural design is needed.

4.1.3 Development of Design Analysis and Evaluation Tools

This is the third area of research required, and it must be done prior to the detailed development of a specific RQAS. Although separate pieces of a design, analysis, and evaluation procedure exist, they have not been integrated into a single comprehensive package. The basic elements of such a package are shown in Figure 25. The actual control algorithm design, whether it be classical or optimal, is well understood and can readily be applied to a RQAS design. Two of the pieces of the analysis and evaluation procedure, that is the turbulence model and the RQI transfer functions (with the exception cited above), are also well understood. The weak link prior to the present time has been the lack of an accurate aircraft model for most of the existing commuter aircraft. This deficiency can now be easily and economically overcome by the use of the portable, inexpensive flight parametric package developed by the FRL-KU under NASA sponsorship. All the pieces exist and must now be integrated into a comprehensive design, analysis and evaluation procedure. The creation of this procedure should be the next step in the RQAS research process.

4.2 RECOMMENDED RIDE QUALITY AUGMENTATION SYSTEM PRELIMINARY DESIGN

Based upon the review of past research it is recommended that the RQAS shown in Table 2 be designed to verify the design and evaluation procedure. The detailed selection criteria are discussed below.

Table 2. Preliminary RQAS Design Configuration

- Longitudinal Axis to Smooth Vertical Accelerations
- Closed Loop Feedback Accelerometer Based System
- Rigid Body Dynamics
- Separate Surface Controls
- Optimal Digital Control with Gain Scheduling

The selection between smoothing only the vertical motion or both the vertical and lateral motion is a tradeoff between need and complexity. As shown in Figures 7, 8 and 9, the lateral accelerations experienced are generally 50% or smaller than the vertical accelerations, so the need for lateral smoothing is not as great. However, the smaller acceleration magnitudes are somewhat counterbalanced by the increased sensitivity of passengers to the lateral accelerations. To further complicate matters,

convenient direct force control surfaces do not exist for the lateral mode as they do for the vertical mode. Of the designs that attempted to control the lateral mode, only one used the rudder for control and that was the L-1011. That particular effort was aimed more at reducing the fuselage bending rather than to attenuate accelerations. Both the University of Virginia design, for implementation on the GPAS [3], and Boeing design for the DHC-6 [11, 12] recommended that lateral ride smoothing be done using dedicated side force control surfaces. The University of Virginia examined the use of the rudder for lateral smoothing, but found it unacceptable. Overall, due to the difficulty involved and the questionable payoff, it is recommended that the normal commuter RQAS be designed to control only the vertical acceleration.

The decision between open and closed loop control laws has been based on several considerations. The open loop is simpler and has been done more often, but it has some rather significant disadvantages. Although some of the early RQAS efforts, most notably the NACA C-45 [4], used a vane sensor successfully, and the Dornier design plans to use a combination of vane and accelerometer system [14], the control algorithm for the vane system still has open loop characteristics. That causes it to be very sensitive to errors in the stability derivatives, the area which is currently the weak link in the analysis procedure. The open loop system could prove difficult to implement over the entire range of flight conditions (gain scheduling). On the other hand, most of the more recent work has been based on the closed loop approach. A closed loop system, implemented through a digital controller using optimal control techniques, would provide the most flexibility and the best means of the gain scheduling. Therefore, the recommendation of this study is to design commuter RQAS using a closed loop accelerometer based system.

Even though a few of the designs reviewed used elastic aircraft equations of motion, it is the recommendation of this study to utilize the simpler rigid aircraft models in the analysis and design. The designs that used the elastic aircraft were for the SST, the L-1011, and the F5 [9, 18 and 13 respectively]. The need for the elastic aircraft equations for the SST and the L-1011 is obvious, and the need for the more complicated analysis of the F-5 was caused by the extremely high dynamic pressures encountered at $M=0.9$ at 500 ft. All of the other designs studied used the rigid aircraft models, and it is felt that for the normal commuter this is a valid approximation.

RQAS designs have been made using either the existing control surfaces or additional separate control surfaces. The use of separate surfaces on a commuter aircraft was demonstrated by the University of Kansas in the Beech 99 SSSAS, and the concept of using separate surfaces for a RQAS was proven by the University of Virginia on the GPAS. This method of mechanization for the RQAS has several advantages. One of the primary ones would be the lack of feedback to the control column of RQAS commands, as is inherent in the reversible control system autopilots used on commuters. Also, because this would not be a flight critical mode, the use of separate surfaces would permit electro-mechanical servos coupled to a digital controller, a reduction in reliability and redundancy requirements, and the later possible addition of advanced SAS and autopilot functions. As shown in the SSSAS program, when the augmentation system is properly designed, the primary controls can override the separate surfaces even in the case of a hard over failure. These characteristics would enhance the acceptance and certification of a RQAS.

The final selection, the one between a classical analog or the more advanced digital controller implementation, is one of the keys to the feasibility of an advanced RQAS. As shown by the review of past work, RQAS have been designed and even flight tested prior to this project. Many of these efforts have demonstrated that the RQAS is technically feasible, and yet it has not been implemented. Many of these efforts have recommended that additional work be done in the area of optimal designs and in gain scheduling, both of which are tasks that are difficult if not impossible to do with analog systems. The dramatic advances in microprocessors, in general, and in their use in digital aircraft systems, in particular, has opened the door to the possibility of digitizing commuter class aircraft. The accompanying advances in digital control systems design make the introduction of a digital system in a commuter in a non-flight critical area an attractive prospect at this time. The inclusion of a low cost microprocessor for the RQAS function might induce the use of digital systems for other functions such as autopilots, navigation, SAS, etc., in addition to the microprocessor's recent introduction in the area of digital displays. It is because of the attractiveness of these possible expansion areas, as well as the direct benefits to the RQAS that the selection of a digital controller is recommended for the commuter RQAS.

Following detailed design, this RQAS should be implemented on a moving base simulator to provide validation of the design, analysis, and evaluation

procedure. The optimal program would also include modification of an existing commuter and an extensive flight test program. This total program should be accomplished in a timely manner to permit inclusion of a RQAS on future commuter aircraft while still in the design stage.

5.0 CONCLUSIONS

5.1 OBJECTIVES

The objectives of this study were to:

1. Review the state-of-the-art of ride quality augmentation systems.
2. Assess the requirement for and the feasibility of implementing a RQAS on a commuter aircraft.
3. Identify further required research.

5.2 CONCLUSIONS

Based on a comprehensive literature search and review of past ride technology, ride quality, and other related research the conclusions of this study are:

1. RQAS can enhance the ride of current and future commuter designs.
2. RQAS are technically feasible and the incorporation of modern control and current hardware technology offer the possibility of an economically feasible system.
3. Fundamental research is required in the areas of separate surface controls, the RQI, gain scheduling, and RQAS-structural interaction.
4. The development of a comprehensive design, analysis and evaluation procedure should be initiated immediately.
5. A program to perform a detailed design, ground based simulation, and flight test of a RQAS for an existing aircraft should be undertaken.

APPENDIX A
RIDE TECHNOLOGY

INTRODUCTION

As discussed in the body of the report, the quality of the ride experienced on a commuter aircraft is of an inferior nature when compared to the larger commercial airliners. In order to boost passenger acceptance of commuters, active RQAS can and should be implemented to reduce the levels of accelerations, or bumps, encountered by these aircraft. However, before designing such a system, both an analytical input (turbulence model), and an analytical performance measure (quantitative ride quality index) must be selected to insure comparability of the various RQAS designs. This appendix examines the current state-of-the-art in basic ride quality technology and recommends an appropriate input and performance measure for use in the design phase.

METHOD OF ANALYSIS

A schematic of the analysis method [26 or 28] to assess ride quality is illustrated in Figure 26. In this section, the analysis method illustrated in Figure 27 will be used, since:

- a. other inputs to the subjective transfer function such as noise, temperature, seating, others will not enter our analysis; and
- b. the effects of cost, time, schedule, others on the subjective value function is really outside the scope of this study.

It should also be noted that the aircraft forcing function would normally be of 3 types:

- a. internal (e.g., engines),
- b. external (e.g., atmospheric turbulence), and
- c. human (e.g., steering).

In this report only atmospheric turbulence will be considered since we are interested in the design of Ride Quality Control Systems.

THE AIRCRAFT FORCING FUNCTION, TRANSFER FUNCTION AND MOTION

The aircraft input forcing function is atmospheric turbulence, which can be characterized as gusts in all six-degrees-of-freedom. However, since

comfort models will require only vertical and lateral linear accelerations (see Eq. A.26), only these components of the turbulence field will be considered.

Statistically defined atmospheric properties show that the gust intensity can be plotted as a function of altitude and probability of exceedance (Figure 28, data from [29]). This clearly shows that turbulence, regardless of the probability, greatly increases at altitudes generally below 15,000 ft. Thus, no matter which methods we pick to input the turbulence, the gust intensity will be much higher for the commuter than for the commercial aircraft flying at 30,000 ft. or higher. The three distinct methods commonly used to model the turbulence are the isolated gust, power spectral density, and the statistical discrete gust concepts and are discussed in detail below.

a. The Isolated Gust (IG) Concept: 1-cosine state

This concept tends to represent rather better the conditions of the extreme event, but the amplitude duration effects are completely lost. The method of analyzing the IG concept [30, 31] is as follows:

The discrete gust has the "1-cosine" shape defined as:

$$v = 0, x < 0$$

$$v = \frac{v_m}{2} \left(1 - \cos \frac{\pi x}{d_m} \right), 0 < x < 2d_m \quad (\text{A.1})$$

$$v = 0, x > 2d_m$$

This equation has a graphical representation as illustrated in Figure 29. The magnitude v_m can be found from Figure 30. The parameters L and σ used in this figure are the Dryden scales and intensities for the velocity component under consideration and are as given in the next section. The effects of several values of d_m should be investigated, each chosen so that the gust is tuned to each of the natural frequencies of the aircraft and its flight control system.

The response of the aircraft to a 1-cosine gust can be found following the methods suggested in Ref. 30. It is not presented here because the other two concepts which follow are more widely used in ride quality studies.

b. The Power Spectral Density (PSD) Concept: Von Karman and Dryden Description

This concept tends to better represent the conditions in which the extreme events are embedded rather than the events themselves. There are two descriptions to the PSD concept:

1. The Von Karman Spectral Form:

This form is usually preferred since it matches closely actual measured spectra but has a disadvantage in that the analyses and computations associated with it are usually more difficult. The method of analysis [30, 31] is as follows:

The Von Karman spectra are given as:

$$\phi_{v_g}(\Omega) = \sigma_v^2 \frac{L_v}{\pi} \frac{1 + \frac{8}{3} (1.339 L_v \Omega)^2}{[1 + (1.339 L_v \Omega)^2]^{11/6}} \quad (\text{A.2})$$

and

$$\phi_{w_g}(\Omega) = \sigma_w^2 \frac{L_w}{\pi} \frac{1 + \frac{8}{3} (1.339 L_w \Omega)^2}{[1 + (1.339 L_w \Omega)^2]^{11/6}} \quad (\text{A.3})$$

where:

v_g, w_g = gust velocities in the Y and Z directions

σ_v, σ_w = gust intensities

Ω = the wave number or spatial frequency

L_v, L_w = scales of turbulence

Equations A.2 and A.3 are defined such that the mean square turbulence velocity is given by integrating the power spectrum over all positive spatial frequencies (Ω) or the temporal frequency ω (rad/sec) sensed by the aircraft. The temporal frequency is related to the spatial frequency by the true airspeed v :

$$\omega = \Omega v \quad (\text{A.4})$$

Therefore, the spectral densities are transformed to functions of ω as follows:

$$\phi_v(\omega) = \frac{1}{v} \phi_{v_g}(\Omega = \frac{\omega}{v}) \quad (\text{A.5})$$

and

$$\phi_w(\omega) = \frac{1}{v} \phi_{w_g} \quad (\Omega = \frac{\omega}{v}) \quad (A.6)$$

The root-mean-square intensity σ_w for clear air turbulence is defined in Figure 31 as a function of altitude. Using the relationship:

$$\frac{\sigma_v^2}{L_v^{2/3}} = \frac{\sigma_w^2}{L_w^{2/3}} \quad (A.7)$$

gives σ_v .

The scales for clear air turbulence using the Von Karman form are:

Above $h = 2500$ ft: $L_v = L_w = 2500$ ft.

Below $h = 2500$ ft: $L_v = 184h^{1/3}$ ft. (A.8)

$L_w = h$ ft.

For thunder storm turbulence, i.e., for severe turbulence, the RMS intensities σ_v and σ_w are both equal to 21 FPS. The scales for thunderstorm turbulence (for altitudes below 40,000 ft.) are:

$$L_v = L_w = 2500 \text{ ft.} \quad (A.9)$$

Since the outputs of interest for the comfort model to be used will be the RMS accelerations in the vertical and lateral directions, these can be obtained by integrating their power spectral densities over frequency space which are given by:

$$\phi_{a_y}(\omega) = \left| \frac{a_y}{v g} \right|^2 \phi_v(\omega) \quad (A.10)$$

and

$$\phi_{a_z}(\omega) = \left| \frac{a_z}{w g} \right|^2 \phi_w(\omega) \quad (A.11)$$

Here, $\left| \frac{a_y}{v g} \right|$ and $\left| \frac{a_z}{w g} \right|$ are the transfer functions for these accelerations relating them to the turbulence field and can be obtained using any standard text on aircraft stability and control (see for e.g. [30]). The RMS accelerations are simply the square root of the integral.

2. The Dryden Spectral Form:

This form when used gives results which do not closely match actual measured spectra but it has the advantage of being spectrally factorable thereby greatly simplifying the analyses and computations. Ref. 32 (synopsis in [33]) shows that results using this form does not give too good a prediction of comfort rating when compared to comfort rating obtained using actual measured motion (but note that deficiencies in the knowledge of the aircraft transfer function may have played a part). The method of analysis [30, 31] is as follows:

The Dryden Spectra are given as:

$$\phi_{v_g}(\Omega) = \sigma_v^2 \frac{L_v}{\pi} \frac{1 + 3(L_v \Omega)^2}{[1 + (L_v \Omega)^2]^2} \quad (\text{A.12})$$

and

$$\phi_{w_g}(\Omega) = \sigma_w^2 \frac{L_w}{\pi} \frac{1 + 3(L_w \Omega)^2}{[1 + (L_w \Omega)^2]^2} \quad (\text{A.13})$$

The RMS intensity σ_w for clear air turbulence is again obtained from Figure 31. Using the relationship:

$$\frac{\sigma_v^2}{L_v} = \frac{\sigma_w^2}{L_w} \quad (\text{A.14})$$

gives σ_v .

The scales for clear air turbulence using the Dryden form are:

$$\begin{aligned} \text{Above } h = 1750 \text{ ft.: } L_v = L_w = 1750 \text{ ft.} \\ \text{Below } h = 1750 \text{ ft.: } L_w = h \text{ ft.} \\ L_v = 145h^{1/3} \text{ ft.} \end{aligned} \quad (\text{A.15})$$

For thunderstorm turbulence, the rms intensities σ_v and σ_w are both equal to 21 FPS. The scales for thunderstorm turbulence (for altitudes below 40,000 ft.) are:

$$L_v = L_w = 1750 \text{ ft.} \quad (\text{A.16})$$

On following the analysis given in the Von Karman Spectral form, we finally get:

$$\phi_{a_y}(\omega) = \left| \frac{a_y}{v_g} \right|^2 \phi_v(\omega) \quad (\text{A.17})$$

and

$$\phi_{a_z}(\omega) = \left| \frac{a_z}{w/g} \right|^2 \phi_w(\omega) \quad (\text{A.18})$$

c. The Statistical Discrete Gust (SDG) Concept

This concept has been developed by Jones [34]. The idea behind this concept is that a system designed to the isolated gust concept would not be satisfactory if subjected to the power spectral density concept and vice versa. Therefore, a unifying theory (i.e., the SDG concept) would resolve such matters. The SDG concept comprises a turbulence model in which families of discrete gusts are used to represent patches of continuous turbulence. Here, the turbulence model takes the form of an aggregate of discrete ramp gust and the families of "equiprobable" ramp gusts follow a law $v_m \sim H^{1/3}$ as illustrated in Figure 32. These statistical characteristics are consistent with the energy distribution defined in the Von Karman spectrum. Thus, it is possible to employ coordinated discrete-gust and power spectral turbulence models both related to a common turbulence reference intensity $\bar{\sigma}$ which acts as an overall measure of atmospheric disturbances and for which probabilities of exceedance are available based on overall global statistics [34]. The relationship between the reference intensity $\bar{\sigma}$ and the true RMS intensity σ_i of a component of turbulence with scale length L is illustrated in terms of power spectra in Figure 33. From this figure:

$$\begin{aligned} \sigma_i^2 &= \text{area under solid curve} \\ \bar{\sigma}^2 &= \text{area under dashed curve.} \end{aligned}$$

Since turbulence intensity is often described qualitatively as light, moderate and severe, such terms may be approximately related to specific values of the reference intensity according to:

- Light: Value of reference intensity = 3 FPS
- Moderate: Value of reference intensity = 6 FPS
- Severe: Value of reference intensity = 12 FPS.

Three concepts which can be used in modelling the turbulence have been presented. A suitable choice must now be found. Although the SDG concept may seem a good choice, the Von Karman description of the PSD concept is suggested. The main reasons for doing this are that:

1. The Von Karman spectra most closely matches actual measured motion.
2. Ref. 32 (synopsis in [33]) shows that results using the Dryden form do not correlate well with the comfort rating obtained using actual measured motion. Taking (1) into consideration, it can be seen that the results would have agreed better if the Von Karman spectra had been used.
3. The SDG concept has not been used to a significant extent yet (such as the one described in (2)) and thus, it cannot be used with much confidence.

If it is not feasible to use the Von Karman form, the Dryden description may then be used as the next best possible choice.

THE SUBJECTIVE TRANSFER FUNCTION

Using the method of analysis presented in the previous section, it is possible to deduce the RMS accelerations of interest to us. These RMS accelerations, when inserted into the equations given below (commonly referred to as Ride Comfort Models), give values of the Ride Comfort Index C which can then be used to compare all the different designs. These Ride Comfort Indices are always given in terms of a rating scale employing descriptors ranging from "very comfortable" to "very uncomfortable" (see Table A.I) and are derived by trying to relate in the best possible manner (e.g., by regression analysis) the actual measured motion experienced on the aircraft/simulator to the test subjects/passengers estimate of their own total comfort at the end of each evaluation period.

Table A.I. Ride Comfort Rating Scales

(a) 7-point Rating Scale

Very Comfortable	1
Comfortable	2
Somewhat Comfortable	3
Neutral	4
Somewhat Uncomfortable	5
Uncomfortable	6
Very Uncomfortable	7

(b) 5-point Rating Scale

Very Comfortable	1
Comfortable	2
Neutral	3
Uncomfortable	4
Very Uncomfortable	5

For ride comfort models, many options are generally available and therefore the best one has to be selected. The various models together with their drawbacks and advantages are:

Model (a)

$$C(5) = 1 + \log_{10} \bar{S}_{\max} + 0.000176(\log_{10} \bar{S}_{\max})^4 [(\log_{10} \bar{S}_1)^4 - (\log_{10} S_{\max})^4] \quad (\text{Ref. 35}) \quad (\text{A.19})$$

where:

\bar{S}_{\max} = maximum value of component \bar{S}_1 (the effective stimulus)

$$\bar{S}_1 = (S_1/S_{T1})^{K_1}$$

S_1 = RMS linear acceleration (\bar{a}_1) or rms angular velocity ($\bar{\omega}_1$)

S_{T1} = Threshold to random linear accelerations or random angular velocities

K_1 = Motion sensitivity coefficient.

This is an unusual model based on the log of stimuli, stimuli being a function of RMS accelerations and angular velocities, some motion sensitivity coefficients and thresholds to random accelerations and angular velocities. This model is not recommended for use in Ride Quality Systems design since when it was used only once [36] the results obtained were completely different from those obtained using other comfort models.

Model (b)

$$C(5) = 1.8 + 11.5 \bar{a}_z + 5.0 \bar{a}_y + 1.0 \bar{a}_x + 0.25 \bar{q} + 0.4 \bar{p} + 1.9 \bar{z} \quad (\text{Ref. 37}) \quad (\text{A.20})$$

This model is also suggested for use in [14]. This model when it was used [36] showed an excellent agreement with model (c), but since it is much more complex, it was rejected in favor of the simpler model (C).

ORIGINAL PAGE IS
OF POOR QUALITY

Model (c)

$$C(5) = 2 + 11.9 \bar{a}_z + 7.6 \bar{a}_y \text{ when } \bar{a}_z > 1.6 \bar{a}_y \quad (\text{A.21})$$

(accelerations encountered in commuter flights)

and

$$C(5) = 2 + \bar{a}_z + 25.0 \bar{a}_y \text{ when } \bar{a}_z < 1.6 \bar{a}_y \quad (\text{A.22})$$

(from simulator data - Jetstar GPAS)

(Ref. 38)

This model was derived using data from in-flight samples on regularly scheduled commercial flights in the north-east region of the United States [38, 39]. Three types of aircraft were involved--the Twin Otter, the Nord 262 and the Volpar Beech 18. The Pearson correlation coefficient is 0.72 for this model.

The observations made for model (b) applies here as well. Ref. 32 (synopsis in [33]) shows that computations based on the motion measurement when inserted in model (c) showed a very good agreement when compared to the actual passenger response. These observations together with the observations made for model (d) (Eq. A.23) suggest that at this stage, model (c) is a very good choice to use.

Model (d)

$$C(7) = 1.65 + 8.32 \bar{a}_x + 15.1 \bar{a}_y + 21.5 \bar{a}_z + 0.183 \bar{p} - 1.20 \bar{q} - 0.238 \bar{r}$$

(Ref. 40)

(A.23)

This model was derived from data obtained using the U. S. Air Force Total In-Flight Simulator (TIFS) aircraft. In Ref. 40, it is shown that there is quite a good agreement with ride-comfort ratings predicted by model (c) and therefore this model is not suggested since it involves 6 degrees-of-freedom and is not in as simple a form as model (c).

Model (e)

$$C(7) = 2 + C_{\text{mot(ion)}} + C_{\text{no(ise)}} + C_{\text{h}} + C_{\text{T}} \quad (\text{Ref. 26 or 28}) \quad (\text{A.24})$$

where:

$$C_{\text{mot}} = 18.9 \bar{a}_z + 12.1 \bar{a}_y \text{ when } \bar{a}_z > 1.6 \bar{a}_y$$

or

$$C_{\text{mot}} = 1.62 \bar{a}_z + 38.9 \bar{a}_y \text{ when } \bar{a}_y < 1.6 \bar{a}_z$$

$$C_{\text{no}} = 0.19 (\text{dB(A)} - 85)$$

$$C_{\text{h}} = 0.005(\dot{h} - 90)\delta_{\text{h}} \text{ where: } \delta_{\text{h}} = 1 \text{ for } \dot{h} > 90 \text{ m/min.}$$

$$\delta_{\text{h}} = 0 \text{ for } \dot{h} < 90 \text{ m/min.}$$

$$C_{\text{T}} = 0.054 (T - 20.5)\delta_{\text{T}} \text{ where: } \delta_{\text{T}} = 1 \text{ for } 2 + C_{\text{mot}} + C_{\text{no}} + C_{\text{h}} > 3.4$$

$$\delta_{\text{T}} = 0 \text{ for } 2 + C_{\text{mot}} + C_{\text{no}} + C_{\text{h}} < 3.4$$

When a comparison is made between this model and model (c), we see that when the observations made in model (c) are taken into consideration rules out model (e) as a possible choice mainly because it is not in as simplified a form as model (c) and has not been verified by comparing it to the actual passenger response as done for model (c).

Model (f)

$$C(10) = 2 + 18.9 \bar{a}_z + 12.1 \bar{a}_y \quad (\text{Ref. 27}) \quad (\text{A.25})$$

This model has been obtained from model (e) after assuming that the effects of C_{no} , C_{h} and C_{T} are negligible and by making use of a 10 point scale (C = 0: smooth ride, C = 10: unacceptable ride).

This model is not suggested for use when the observations made for model (c) are taken into consideration, the main reason being that the assumptions made for this model have not been verified by comparing the predicted comfort ratings with the actual passenger ratings, and therefore this model cannot be used with much confidence.

Model (g)

$$C(7) = 2 + 17.2 \bar{a}_z + 17.1 \bar{a}_y \quad (\text{Ref. 41}) \quad (\text{A.26})$$

The Pearson correlation coefficient for this model is 0.75 and on the basis of this information we see that this model is preferred to model (c). The value of the Pearson coefficient is better here since the model was obtained using more refined data than that used for model (c). These were [41, 42]:

1. Four types of aircraft were used: the Twin Otter, the Nord 262, the Beech 99, and the Sikorsky S-61 helicopter whereas for model (c) the three types of aircraft used were the Twin Otter, the Nord 262, and the Volpar Beech 18.
2. A revised questionnaire and
3. New samples of passengers.

The approach used was to assume a particular model and then see how well it does in describing the available data. Model (g) was developed using this approach.

The correlations of values predicted by this model with comfort responses from the test subjects are presented below to see how well the model does in describing the data of these four aircraft:

Nord 262: $r = 0.63$ ($n = 134$)

Twin Otter: $r = 0.80$ ($n = 263$)

Beech 99: $r = 0.80$ ($n = 262$)

Airplanes Only: $r = 0.75$ ($n = 659$)

Sikorsky S-61: $r = 0.49$ ($n = 69$)

All Aircraft: $r = 0.74$ ($n = 728$).

From this we see that the model displays exceptionally good fit to the data from all aircraft together, all airplanes, the Beech alone and the Twin Otter alone. The Nord data fits less well but still the fit is acceptable. Only the S-61 data fails to conform well to the model, but this model is as good as one can get using all motion variables as shown below:

Nord 262: $r = 0.65$ ($n = 134$)
Twin Otter: $r = 0.82$ ($n = 263$)
Beech 99: $r = 0.83$ ($n = 262$)
All Airplanes: $r = 0.76$ ($n = 659$)
Sikorsky S-61: $r = 0.56$ ($n = 69$)
All Aircraft: $r = 0.75$ ($n = 728$).

For all airplanes, we see that this model gives an excellent agreement when compared to the pearson correlation coefficient using all motion variables which is only 1% better and hardly justifying the added complexity. Model (g) is, therefore, the best type to use now.

After extensive NASA sponsored research, the authors of Ref. 41 suggest using this model in RQ analysis. The observations made in this section from model (a) to model (g) leads also to this conclusion.

THE VALUE TRANSFER FUNCTION AND SATISFACTION DECISION

To potential users of RQ criteria, the key factor is passenger satisfaction or desire to take another trip by this mode of transportation. The value-oriented variable chosen is therefore the percentage of passengers satisfied with the ride, i.e., the fraction of passengers who when queried at the conclusion of a flight said they would be willing to take another flight without any hesitation. Based on data from questionnaires completed by passengers on board regularly scheduled commercial flights [41, 42] the satisfaction relation shown graphically in Figure 34 was established. The heavy dots in Figure 34 represent data from the first flight program [38, 39], i.e., of model (c). Thus, it can be deduced that passengers in both flight programs relate the comfort scale to satisfaction in the same way. Also, the relationship between comfort and willingness to fly again is not only replicated, but the meaningfulness of the scale labels is supported by this replication.

The message to the airlines therefore is, if you wish to have a certain percentage of the passengers with no doubts about flying again, provide a flight which yields a comfort rating associated with this percentage. This in turn implies that the root-mean-square accelerations must not be allowed to exceed the values associated with this particular comfort rating.

ORIGINAL PAGE IS
OF POOR QUALITY

The discussion considered above takes into account only the overall comfort ratings of the passengers. During an aircraft flight, a series of unique ride events is experienced by the passengers. While the mean comfort rating for each of these events can be established by application of the comfort rating model (g), the problem remains concerning the manner in which these "local" comfort ratings (experiences) can be integrated to obtain an overall response for the entire flight. This problem was addressed in Ref. 39 where an approximate relationship was established for weighting the series of local comfort ratings into a rating which closely matched the passengers' overall trip comfort rating. For a series of local ride events of equal time duration:

$$E_1, E_2, E_3, \dots, E_n$$

the corresponding weighting factors to be applied to the event comfort rating can be expressed as:

$$1^{3/4}, 2^{3/4}, 3^{3/4}, \dots, n^{3/4}.$$

This relationship, a 3/4-power weighting function, is assumed appropriate for weighting any series of local mean comfort rating experiences into an expected total trip mean reaction of passengers. This weighting implies that a memory decay occurs (events at the beginning of a flight being less important than events at the end) such that a passenger's overall reaction to the flight is a stronger function of the later portions of the flight than at the beginning. The total trip comfort rating in equation form is:

$$C_{\text{trip}} = \frac{\sum_{E=1}^n E^{3/4} C_E}{\sum_{n=1}^n E^{3/4}} \quad (\text{A.27})$$

CONCLUSIONS AND RECOMMENDATIONS

The current state-of-the-art in Ride Quality technology for application to the design of Active Ride Quality Control Systems can be considered sufficiently complete and can be applied with confidence to provide reliable

results. The recommended approach is to model the atmospheric turbulence with the Von Karman Spectra, which together with the aircraft transfer function would yield the RMS transverse and vertical linear accelerations. These accelerations can then be related to the comfort ratings of the passengers with the ride comfort rating model suggested below:

$$C(7) = 2 + 17.2 \bar{a}_z + 17.1 \bar{a}_y$$

This Ride Comfort Index can then be related to the percentage of passengers satisfied with the ride. The RQI or the percentage of passengers satisfied with the ride can be compared to the unaugmented aircraft, the various RQAS designs, or to an aircraft such as the Boeing 737. In this way, a relatively meaningful comparison can be made.

APPENDIX B
BIBLIOGRAPHY OF LITERATURE SEARCH

- The Boeing Company: Selected Advanced Aerodynamic and Active Control Concept Developments. NASA CR-3220, January 1980.
- Johnston, J. F.: Accelerated Development and Flight Evaluation of Active Control Concepts for Subsonic Transport Aircraft. NASA CR-159097, Volume 1, September 1979.
- Urie, D. M.: Accelerated Development and Flight Evaluation of Active Control Concepts for Subsonic Transport Aircraft. NASA CR-159098, Volume 2, September 1979.
- Anderson, L. R.: Computational Methods of Robust Controller Design for Aeronautical Flutter Suppression. NASA CR-164983, November 1981.
- Theory and Application of Optimal Control in Aeronautical Systems. NTIS AGARD-AG-251: ISBN-92-835-139-6, 1982.
- A Method for Determination of the Aeroelastic Behavior of Aircraft with Active Control Systems. NTIS N82-10047, DFVLR-FB-81-05, 1982.
- Berry, D. T.: Flying Qualities: A Costly Lapse in Flight-Control Design? Astronautics and Aeronautics, April 1982.
- Roskam, J.: Forward Swept Wings and Commuter Aircraft. University of Bristol, International Forward Swept Wing Conference, Bristol (U.K.), March 1982. (University of Kansas Flight Research Laboratory, Report No. KU-FRL-543-P4).
- Groom, N. J.; Hood, R. V.: Electric Flight Systems. NASA CP-2209, 1981.
- Integrated Application of Active Control Technology to Advanced Subsonic Transports. NASA CR-46691, 1981.
- Williams, L.: Can Advanced Technology Improve Future Commuter Aircraft. AIAA-81-1729, AIAA Aircraft Systems and Technology Conference, August 1981..
- Advanced Aerodynamics and Active Controls. NASA CP-2172, 1981.
- Marti, V. M.; Woods, J. J.; Swartz, W. F.: The Anatomy of a Technology Test Bed-Integrated Flight/Fire Control. SAE Paper No. 811036, 1981.
- Rembleske, C. A.: Designing for Continued Airworthiness -- General Aviation. SAE Paper No. 811038, 1981.
- Koch, J. R.: Airworthiness Considerations in the Design of Commercial Transport Aircraft. SAE Paper No. 811039, 1981.
- Treacy, J. J.: FAA Certification Criteria for Critical and Essential Digital Systems. SAE Paper No. 811060, 1981.
- Mehl, B.; Ruffner, G.: The Impact of the Microprocessor on Aircraft Electric System Control Philosophy. SAE Paper No. 811085, 1981.
- Jones, J. G.: Ride Bumpiness and the Influence of Active Control Systems. N80-29991 20/2748, Royal Aircraft Establishment, 1980.
- Coussens, T. G.; Tullis, R. H.: Application of Advanced Technology to Small Short-Haul Transport Aircraft. NASA CR-152363, June 1980.

- Stone, R. W.: Human Comfort Response to Dominant Random Motion in the Longitudinal Modes of Aircraft. NASA CR-159186, January 1980.
- Jones, J. G.: Design of Control Laws to Implement ACT Benefits. Aeronautical Journal, January 1980.
- Conner, D. W.: Passenger Comfort Technology for System Decision Making. NASA TM-81875, 1980.
- B-1 Ride Quality. N79-16876 8/942, 1979.
- Nardi, L. U.; et al.: Ride Quality Criteria Validation/Pilot Performance Study: Flight Test Results. NASA CR-144885, September 1979.
- Bendixen, G. E.; O'Connell, R. F.; Siegert, C. D.: Digital Active Control System for Load Alleviation for the L-1011, 1979.
- Hitch, H. P. V.: Active Controls for Civil Aircraft. Aeronautical Journal, October 1979.
- Phillips, W. H.: Gust Alleviation in "Performance and Dynamics of Aerospace Vehicles." NASA SP-258, 1971.
- Krag, B.: Active Control Technology for Gust Alleviation. Von-Karman Institute Lecture Series 1979-1, January 1979.
- Avionics and Controls Research and Technology. NASA CP-2061, 1979
- Fry, D.E.; Winter, J.S.: The Design of Aircraft Automatic Ride Systems Using Direct Lift Control. RAE-TR-79045, 1979.
- Dempsey, T. K.; et al.: Investigation of a Ride Quality Rating Scale. NASA TP-1064, February 1978.
- Powers, B. G.: Analytical Study of Ride Smoothing Benefits of Control System Configuration Optimized for Pilot Handling Qualities. NASA TP-1148, February 1978.
- Open Loop Gust Alleviation. N78-22114 13/1667, BMFT-FB-W-77-22, 1978.
- Moynes, J. P.; Gallagher, J. T.: Flight Control System Designed for Ride Quality of Highly Maneuverable Fighter Aircraft. N78-26054 17/2204, Northrop Corporation, 1978.
- Jones, J. G.; Fry, D.E.: Aircraft Ride Bumpiness and the Design of a Ride Smoothing System. N78-26053 17/2203, 1977.
- Jacobson, I. D.; Kuhlthau, A. R.; Richards, L. G.; Connor, D. W.: Passenger Ride Quality in Transport Aircraft. Journal of Aircraft, Vol. 15, No. 11, November 1978.
- 1976 Workshop on Ride Quality Passenger Acceptance. NASA CP-2006, DOT-TST-77-38, 1977.
- Roberts, P. A.; Swain, R. L.; Schmidt, D. K.; Hinsdale, A. J.: Effect of Control Laws and Relaxed Static Stability on Vertical Ride Quality of Flexible Aircraft. NASA CR-143843, April 1977.
- Noback, J.: Aircraft Design Loads due to Non-Stationary Atmospheric Turbulence Problems. RAE-TR-78073, 1978.
- Validation of Passenger Ride Quality Apparatus (PRQA) for Simulation of Aircraft Motion for Ride Quality Research. NASA CR-154892, 1977.

- Kuhlthau, A. R. et al.: The Development of a Model for Predicting Passenger Acceptance of Short-Haul Air Transport Systems. NASA CR-145250, September 1977.
- McKenzie, J. R.; Brumaghim, S. H.: User Evaluation of Ride Technology Research. NASA CR-2746, November 1976.
- Connor, D. W.; Jacobson, I. D.: Passenger Ride Comfort Technology for Transport Aircraft Situations. NASA TMX-73953, October 1976.
- Simpson, A.; Hitch, H. P. Y.: Active Control Technology. Aeronautical Journal, June 1977.
- Ellis, S.: A Presentation of Measured Aircraft Responses in Turbulence During Civil Operations. RAE-TR-78113, 1978.
- Khulthau, A. R.: Summary Report: Workshop on Vehicle Ride Quality. NASA CP-2013, 1977.
- Advanced Control Technology and its Potential for Future Transport Aircraft. NASA TM X-3409, August 1976.
- Oehman, W. I.: Optimum Design Characteristics of a Gust Alleviator for Aircraft. NASA TND-8152, March 1982.
- Connor, D. W.; Thompson, G. O.: Potential Benefits to Short-Haul Transports Through the Use of Active Controls. AGARD-CP-157, Paper 3, October 1974.
- Kuhlthau, A. R.: Proceedings and Findings of the 1976 Workshop on Ride Quality. NASA CP-2006, DOT-TST-77-38, October 1976.
- 1975 Ride Quality Symposium. NASA TM X-3295, DOT-TSC-OST-75-40, 1975.
- Taylor, J.: Atmospheric Turbulence Loads on Aircraft. RAE-TR-77116, 1977.
- Schoonover, W. E.; Dittenhauser, J.: Ride-Quality Testing under Controlled Flight Conditions. AIAA Paper No. 75-987, August 1975.
- Lapins, M.; Jacobson, I.D.: Application of Active Control Technology to Aircraft Ride Smoothing Systems. NASA CR-145980, May 1975.
- The Cessna Aircraft Company: Design of a Ride Comfort System for a Cessna 172K Aircraft. NASA CR-14013, April 1975.
- Collins, D. J.; Bolton, W. R. Jr.: A Separate Surface Stability Augmentation System for a General Aviation Aircraft. D.E. Project Report, The University of Kansas, April 1974.
- Jones, J. G.: Aircraft Longitudinal Ride-Bumpiness: An Application of Statistical Discrete Gust Theory. RAE-TR-77020, 1977.
- Healy, M.; Al-Bahrani, H. M. S.: Design of a Digital-Stability Augmentation and Control System with Gust Alleviation and Model Suppression. December 1974.
- Hoffman, L. G.; Clement, W. F.: Vehicle Design Considerations for Active Control Application to Subsonic Transport Aircraft. NASA CR-2408, August 1974.
- Active Control Systems for Load Alleviation, Flutter Suppression and Ride Quality. AGARDograph No. 175, 1974.

- Stone, R. W. Jr.: Ride Quality -- An Exploratory Study and Criteria Development. NASA TMX-71922 (Also in NASA TMX-2620), 1974.
- Loschke, P. C.; Barber, M. R.; Enevoldson, E. K.; McMurty, T. C.: Flight Evaluation of Advanced Control Systems and Displays on General Aviation Aircraft. NASA TN-7703, 1974.
- Dodson, R. O.; Gordon, C. K.: STOL Ride Control Feasibility Study. NASA CR-2276, 1973.
- Kuhlthau, A. R.; Jacobson, I. D.: Analysis of Passenger Acceptance of Commercial Flights Having Characteristics Similar to STOL. CASI Journal, Vol. 19, No. 8, pp. 405-409, October 1973.
- B-52 CCV Ride Control Analysis and Flight Test. AIAA Paper No. 73-782, 1973.
- Effect of Yaw Damper on Lateral Gust Loads in the Design of the L-1011 Transport. 37th AGARD Structures and Materials Panel, August 1973.
- Holloway, R. D.: Introduction of CCV Technology into Airplane Design. AGARD-CP-147, Vol. 1, Paper No. 23, October 1973.
- Roskam, J.: Separate Surfaces for Automatic Flight Control. SAE Paper No. 730304, SAE National Business Aircraft Meeting, 1973.
- Roskam, J.; Henry, S. A.: An Approach to the Synthesis of Separate Surface Automatic Flight Control Systems. AIAA Paper No. 73-834, August 1973.
- Henry, S. A.: Some Methods of Analyzing Aircraft with Linear Automatic Controls. Ph.D. Dissertation, The University of Kansas, 1973.
- Oehman, W. I.: Analytical Study of the Performance of a Gust Alleviation System for a STOL Airplane. NASA TN-D-7201, 1973.
- Holloway, R. B.; Thompson, G. O.; Rohling, W. J.: Prospects for Low Wing-Loading STOL Transports with Ride Smoothing. Journal of Aircraft, Volume 9, No. 8, August 1972.
- 1972 Symposium on Vehicle Ride Quality. NASA TMX-2620, 1972.
- Roskam, J.; Van Deventer, F.: A Survey of Actuating and Sensing Equipment for General Aviation Aircraft. University of Kansas Flight Research Laboratory, Report No. KU-FRL-305, August 1972.
- STOL Technology 1972. NASA SP-320, 1972.
- Heath, R. E. II: State Variable Model of Wind Gusts. AFFDL/FGC-TM-72-12, July 1972.
- Hoblit, F. M.; Paul, N.; Shelton, J. D.: Development of a Power Spectral Gust Design Procedure for Civil Aircraft. FAA-ADS-53, January 1966.
- Press, H.; Meadows, M. T.; Hadlock, I.: A Reevaluation of Data on Atmospheric Turbulence and Airplane Gust Loads for Application in Spectral Calculations. NACA Report-1272, 1956.
- Phillips, W. H.; Kraft, C. C. Jr.: Theoretical Study of Some Methods for Increasing the Smoothness of Flight Through the Air. NACA-TN-2416, 1951.
- Downing, D. R.; Bryant, W. H.; Ostroff, A. J.: Flight Test of a VTOL Digital Autoland System Along Complex Trajectories. AIAA Guidance and Control Conference, August 1979.

- Jacobson, I. D.: Construction and Verification of a Model of Passenger Response to STOL Aircraft Characteristics. SAE (preprint) 760526, May 1976.
- Schoonover, W. E. Jr.: Ride Quality of Terminal-Area Flight Maneuvers. NASA TMX-3295, DOT-TSC-OST-75-40, 1975.
- Jacobson, I. D.; Richards, L. G.: Ride Quality Evaluation I: Questionnaire Studies of Airline Passenger Comfort. Ergonomics, Volume 18, No. 2, March 1975.
- Jacobson, I. D.; Richards, L. G.: Ride Quality Evaluation II: Modelling of Airline Passenger Comfort. Ergonomics, Volume 19, No. 1, January 1976.
- Jacobson, I. D.; Richards, L. G.: Ride Quality Assessment III: Questionnaire Results of a Second Flight Program. Ergonomics, Volume 20, No. 5, September 1977.
- Jacobson, I. D.; Richards, L. G.: Ride Quality Evaluation IV: Models of Subjective Reaction to Aircraft Motion. Ergonomics, Volume 21, No. 7, July 1978.
- Renz, R. R. L.; et al.: Development of a Simple, Self-contained Flight Test Data Acquisition System. SAE Paper No. 810596, SAE Business Aircraft Meeting and Exposition, April 1981. (University of Kansas, Flight Research Laboratory, Report No. KU-FRL-407-P3.)
- "The Grass Roots Airlines are Digging In, and How." Aviation Week and Space Technology, June 14, 1982.
- Halyo, N.; Broussard, J. R.: A Convergent Algorithm for the Stochastic Infinite--Time Discrete Optimal Output Feedback Problem. NASA Contract 1-15759 to ICS, Inc.
- Broussard, J. R.; Downing, D. R.; Bryant, W. H.: Design and Flight Testing of a Digital Optimal Control General Aviation Autopilot. AIAA Aircraft Systems and Technology Conference, August 1982.
- Downing, D. R.; Bryant, W. H.: Flight Test Evaluation of a Digital Controller used in a VTOL Automatic Approach and Landing System. IEEE Conference on Decision and Control, December 1979.

REFERENCES

1. Williams, L.: Can Advanced Technology Improve Future Commuter Aircraft. AIAA-81-1729, AIAA Aircraft System and Technology Conference, August 1981.
2. Phillips, W. H.: Gust Alleviation in "Performance and Dynamics of Aerospace Vehicles." NASA SP-258, 1971.
3. Lapins, M.; Jacobson, I.D.: Application of Active Control Technology to Aircraft Ride Smoothing Systems. NASA CR-145980, May 1975.
4. Phillips, W. H.; Kraft, C. C. Jr.: Theoretical Study of Some Methods for Increasing the Smoothness of Flight through the Air. NACA TN-2416, 1951.
5. Holloway, R.D.; Thompson, G.O.; Rohling, W.J.: Prospect for Low Wing-Loading STOL Transports with Ride Smoothing. Journal of Aircraft, Vol. 9, No. 8, August 1972.
6. Jones, J. G.; Fry, D.E.: Aircraft Ride Bumpiness and Design of a Ride Smoothing System. N-78-26053 17/2203, Royal Aircraft Establishment, 1977.
7. Jones, J. G.: Ride Bumpiness and the Influence of Active Control Systems. N80-29991 20/2748, Royal Aircraft Establishment, 1980.
8. Coussens, T. G.; Tullis, R. H.: Application of Advanced Technology to Small Short-Haul Transport Aircraft. NASA CR-152363, June 1980.
9. Healey, M.; Al-Bahrani H.M.S.: Design of a Digital-Stability Augmentation and Control System with Gust Alleviation and Modal Suppression. December 1974.
10. Cessna Aircraft Company: Design of a Ride Comfort System on a Cessna 172K Aircraft. NASA CR-14013, April 1975.
11. Advanced Control Technology and its Potential for Future Transport Aircraft. NASA TMX-3409, August 1976.
12. Conner, D.W.; Thompson, G.O.: Potential Benefits to Short-Haul Transports Through the Use of Active Controls. AGARD CP-157, Paper 3, October 1974.
13. Moynes, J. F.; Gallagher, J. T.: Flight Control System Designed for Ride Quality of Highly Maneuverable Aircraft. N78-26054 17/2204, Northrop Corporation, 1978.
14. Krag, B.: Active Control Technology for Gust Alleviation. Von-Karman Institute Lecture Series 1979-1, January 1979.

PRECEDING PAGE BLANK NOT FILMED

ORIGINAL PAGE IS
OF POOR QUALITY

15. Collins, D.J.; Bolton, W.R. Jr.: A Separate Surface Stability Augmentation System for a General Aviation Aircraft. D.E. Project Report, University of Kansas, April 1974.
16. Roskam, J.: Separate Surfaces for Automatic Flight Control. SAE Paper 730304, SAE National Business Aircraft Meeting, 1973.
17. Roskam, J.; Henry, S.A.: An Approach to the Synthesis of Separate Surface Automatic Flight Control Systems. AIAA paper 73-834, August 1973.
18. Bendixen, G.E.; O'Connell, R.F.; Siegert, C.D.: Digital Active Control System for Load Alleviation for the L-1011, 1979
19. Downing, D.R.; Bryant, W.H.; Ostroff, A.J.: Flight Test of a VTOL Digital Autoland System Along Complex Trajectories. AIAA Guidance and Control Conference, August 1979.
20. Downing, D.R.; Bryant, W.H.: Flight Test Evaluation of Digital Controller Used in a VTOL Automatic Approach and Landing System. IEEE Conference on Decision and Control, December 1979.
21. Broussard, J.R.; Downing, D.R.; Bryant, W.H.: Design and Flight Testing of a Digital Optimal Control General Aviation Autopilot. AIAA Aircraft Systems and Technology Conference, August 1982.
22. Halyo, N.; Broussard, J.R.: A Convergent Algorithm for the Stochastic Infinite-Time Discrete Optimal Output Feedback Problem. 1981 Joint Automatic Control Conference, June 17-19, 1981.
23. Renz, R.R.L.; et al.: Development of a Single, Self-contained Flight Test Data Acquisition System. SAE Paper 810596, SAE Business Aircraft Meeting and Exposition, April 1981. (University of Kansas, Flight Research Laboratory, Report No. KU-FRL-407-P3.)
24. "The Grass Roots Airlines are Digging In, and How." Aviation Week and Space Technology, June 14, 1982.
25. Groom, N.J.; Hood, R.V.: Electric Flight Systems. NASA CP-2209, 1981.
26. Conner, D.W.; Jacobson, I.D.: Passenger Ride Comfort Technology for Transport Aircraft Situations. NASA TMX-73953, October 1976.
27. Roskam, J.: Forward Swept Wings and Commuter Aircraft. University of Bristol, International Forward Swept Wing Conference, Bristol (U.K.), March 1982. (University of Kansas, Flight Research Laboratory, Report No. KU-FRL-543-P40.)
28. Jacobson, I. D.; Kuhlthau, A. R.; Richards, L. G.; Connor, D. W.: Passenger Ride Quality in Transport Aircraft. Journal of Aircraft, Vol. 15, No. 11, November 1978.
29. MIL-F-8785C: Military Specification of Flying Qualities of Piloted Airplanes. November 1980.

30. Roskam, J.: Airplane Flight Dynamics and Automatic Flight Controls, Part II. Roskam Aviation and Engineering Corporation, Ottawa, Kansas. 1979 Edition.
31. MIL-F-8785B: Military Specification -- Flying Qualities of Piloted Airplanes. August 1969.
32. Jacobson, I. D.: Construction and Verification of a Model of Passenger Response to STOL Aircraft Characteristics. SAE (preprint) 760526, May 1976.
33. Ruhlthau, A. R.; et al.: The Development of a Model for Predicting Passenger Acceptance of Short-Haul Air Transport Systems. NASA CR-145250, September 1977.
34. Jones, J. G.: Aircraft Longitudinal Ride-Bumpiness: An Application of Statistical Discrete Gust Theory. RAE-TR-77020, 1977.
35. Stone, R. W. Jr.: Ride Quality -- An Exploratory Study and Criteria Development. NASA TMX-71922 (Also in NASA TMX-2620), 1974.
36. Powers, B. G.: Analytical Study of Ride Smoothing Benefits of Control System Configuration Optimized for Pilot Handling Qualities. NASA TP-1148, February 1978.
37. 1972 Symposium on Vehicle Ride Quality. NASA TMX-2620, 1972.
38. Jacobson, I. D.; Richards, L. G.: Ride Quality Evaluation II: Modelling of Airline Passenger Comfort. Ergonomics, Volume 19, No. 1, January 1976.
39. Jacobson, I. D.; Richards, L. G.: Ride Quality Evaluation I: Questionnaire Studies of Airline Passenger Comfort. Ergonomics, Volume 18, No. 2, March 1975.
40. Schoonover, W. E. Jr.: Ride Quality of Terminal-Area Flight Maneuvers. NASA TMX-3295, DOT-TSC-OST-75-40, 1975.
41. Jacobson, I. D.; Richards, L. G.: Ride Quality Evaluation IV: Models of Subjective Reaction to Aircraft Motion. Ergonomics, Volume 21, No. 7, July 1978.
42. Jacobson, I. D.; Richards, L. G.: Ride Quality Assessment III: Questionnaire Results of a Second Flight Program. Ergonomics, Volume 20, No. 5, September 1977.

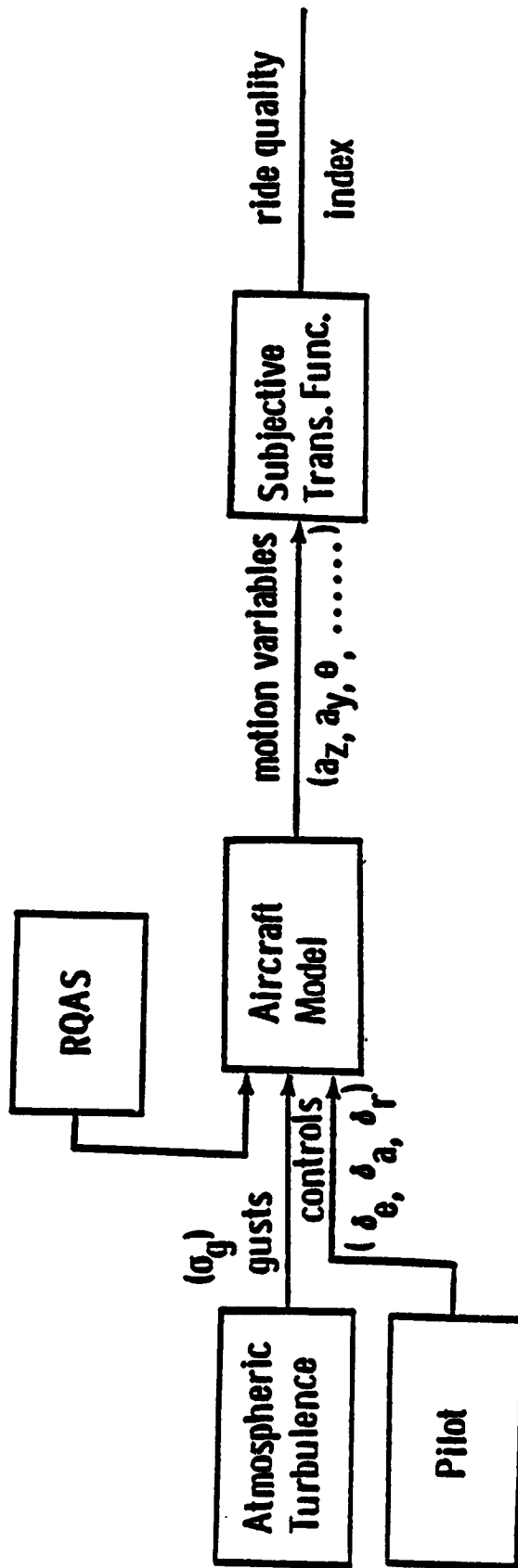

ORIGINAL PAGE IS
OF POOR QUALITY

Figure 1. - Basic Analytical System.

ORIGINAL PAGE IS
OF POOR QUALITY

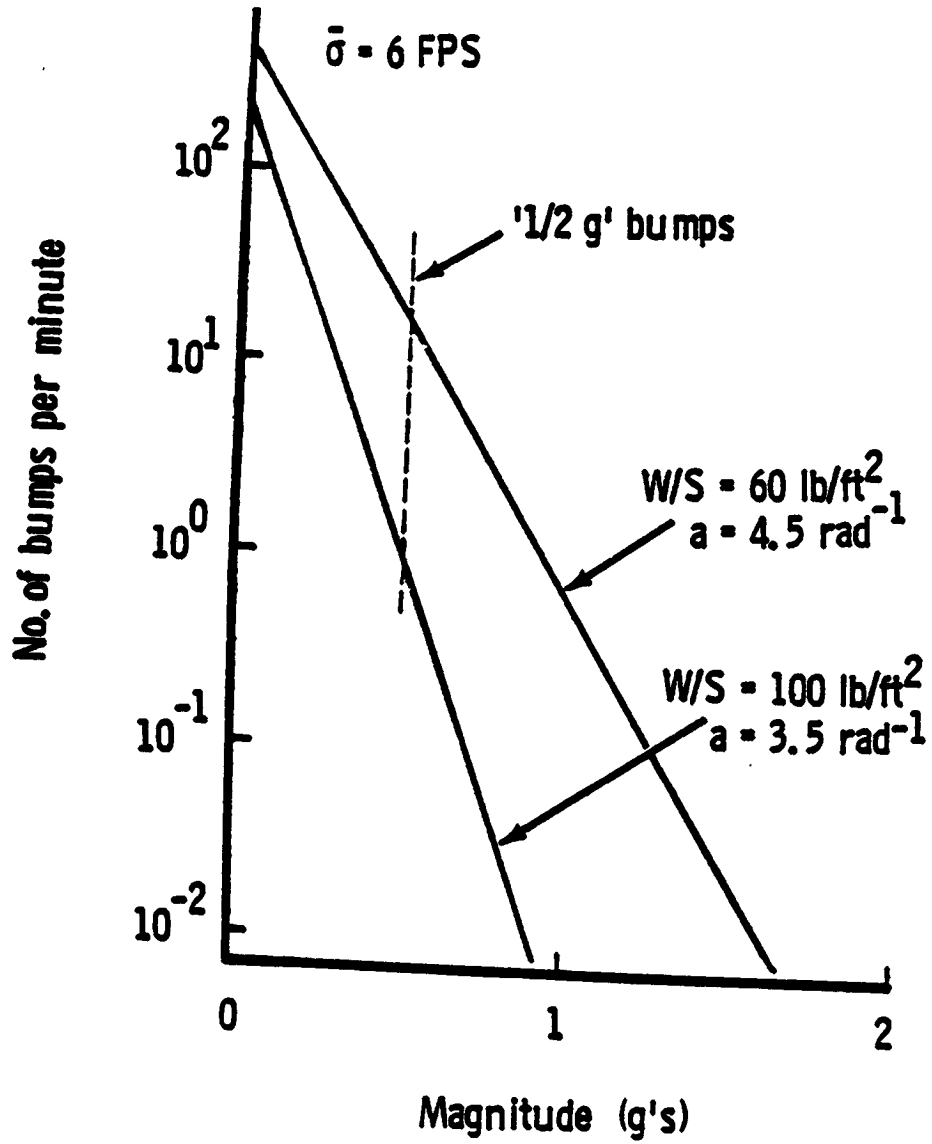

Figure 2. - Influence of W/S and Lift Curve Slope (a) on Ride Bumpiness.

ORIGINAL PAGE 13
OF POOR QUALITY

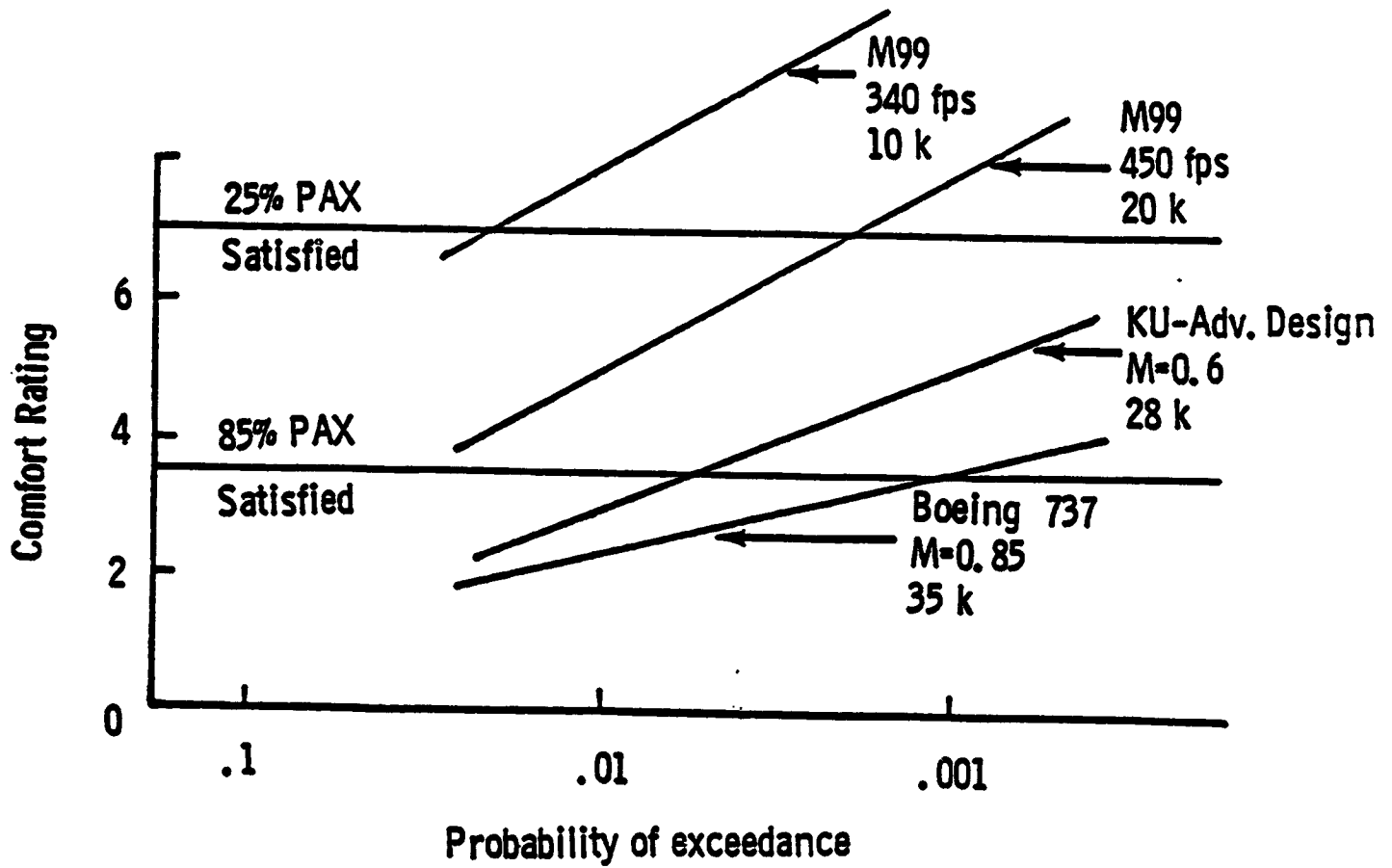

Figure 3. - Comparison of Comfort Rating for Various Airplane Types.

ORIGINAL PAGE IS
OF POOR QUALITY

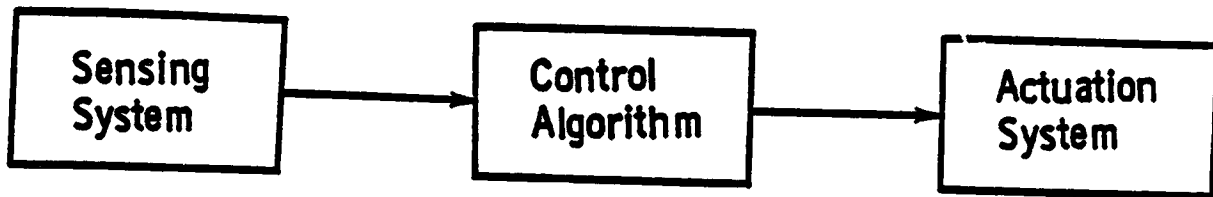
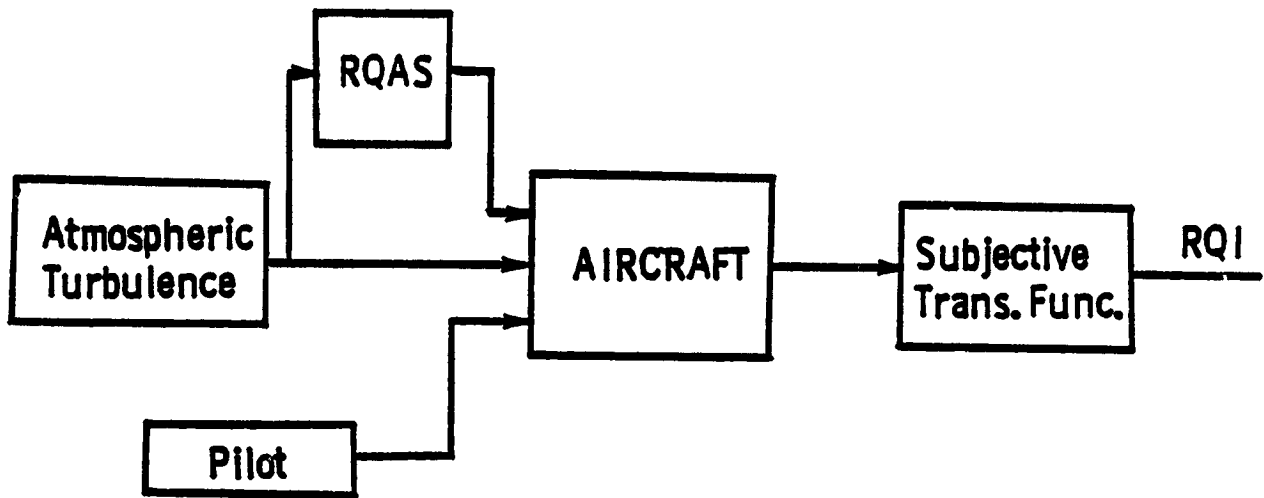

Figure 4. - RQAS Subsystems.

ORIGINAL PAGE IS
OF POOR QUALITY

OPEN LOOP SYSTEM



CLOSED LOOP SYSTEM

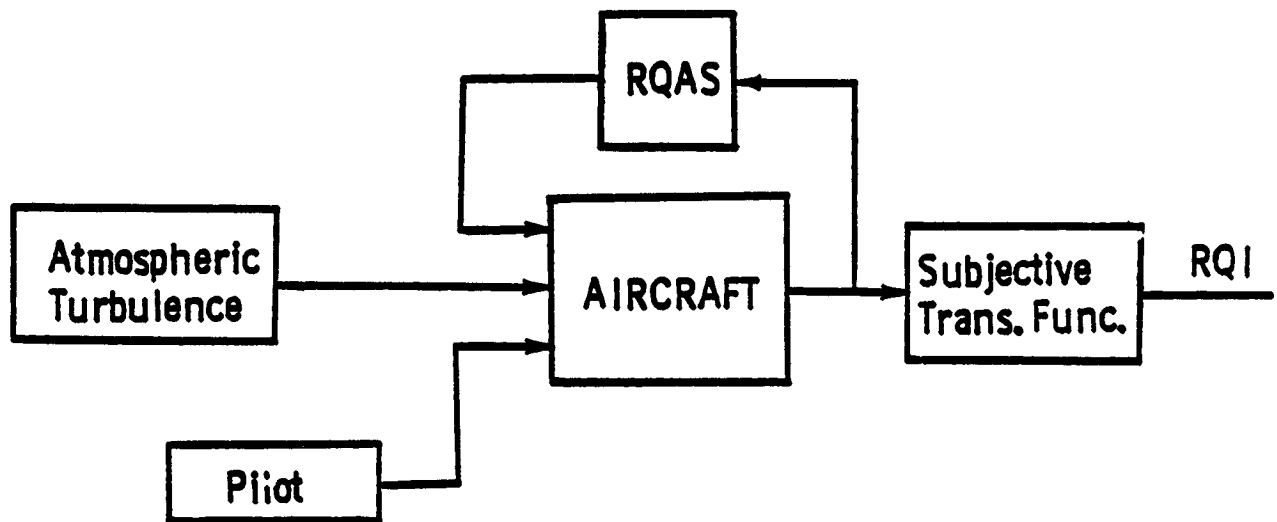

Figure 5. - Block Diagrams of Open and Closed RQAS.

ORIGINAL PAGE IS
OF POOR QUALITY

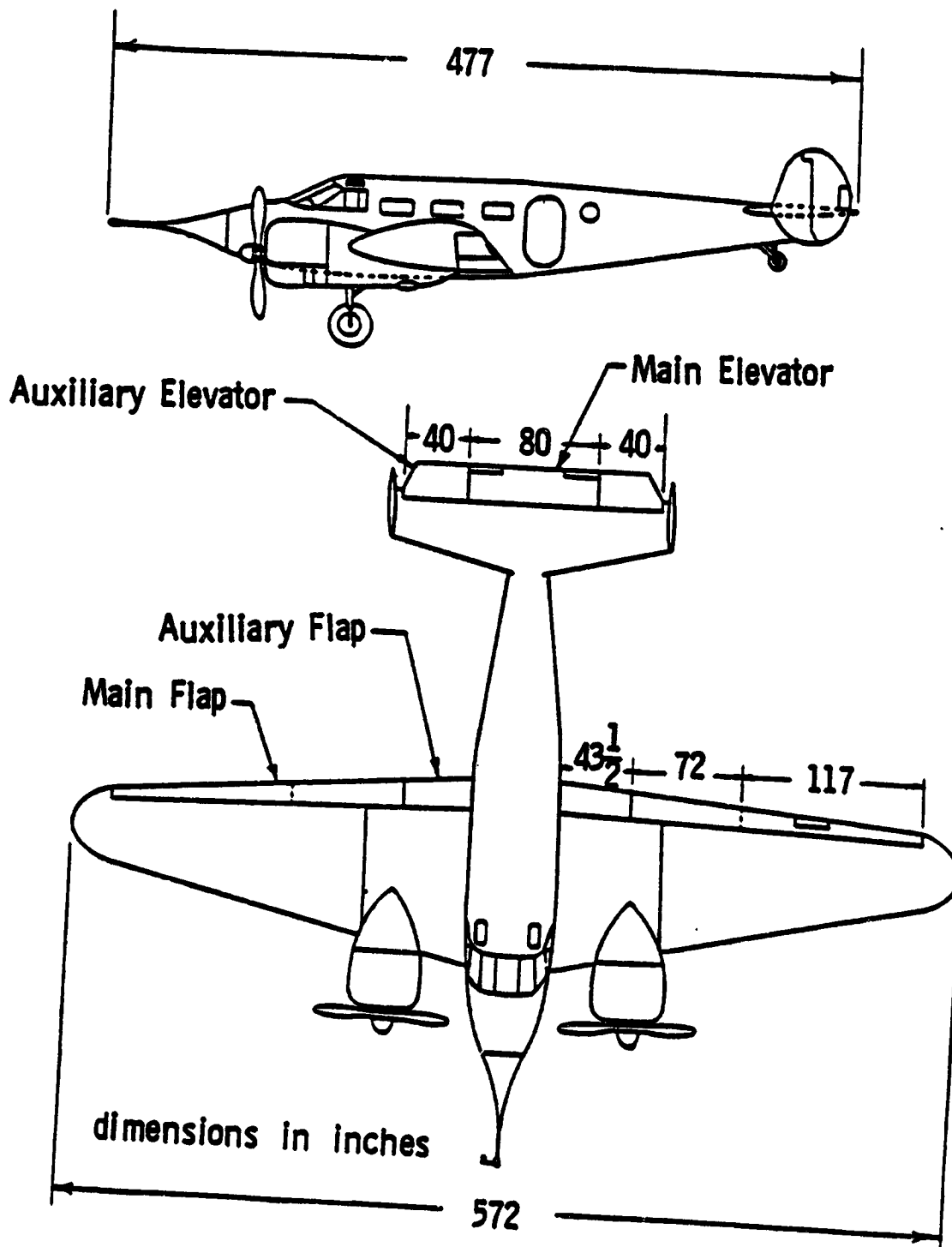

Figure 6. - NACA RQAS Test Aircraft.

ORIGINAL PAGES
OF POOR QUALITY

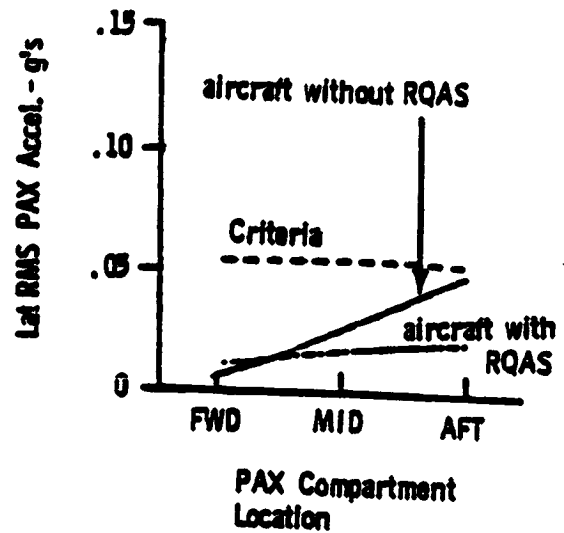
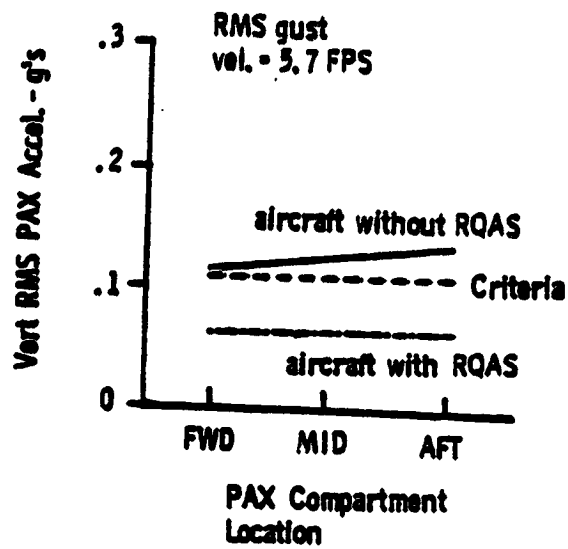

Figure 7. - Passenger Ride Quality During Cruise.

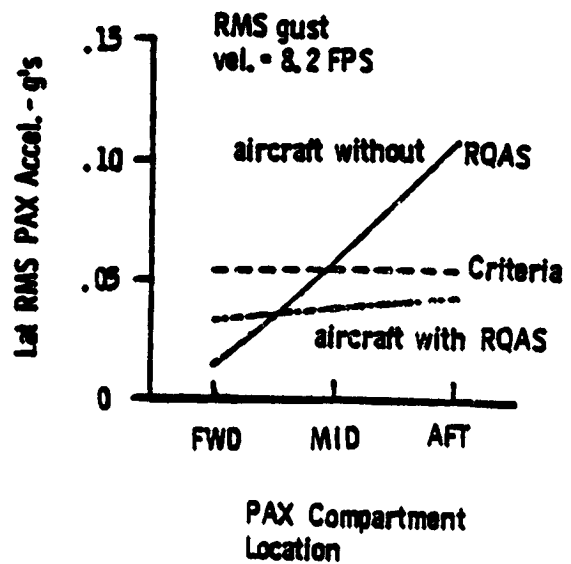
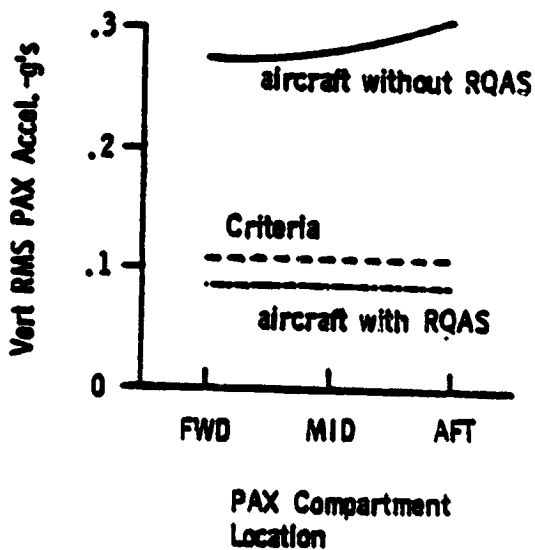

Figure 8. - Passenger Ride Quality During Descent.

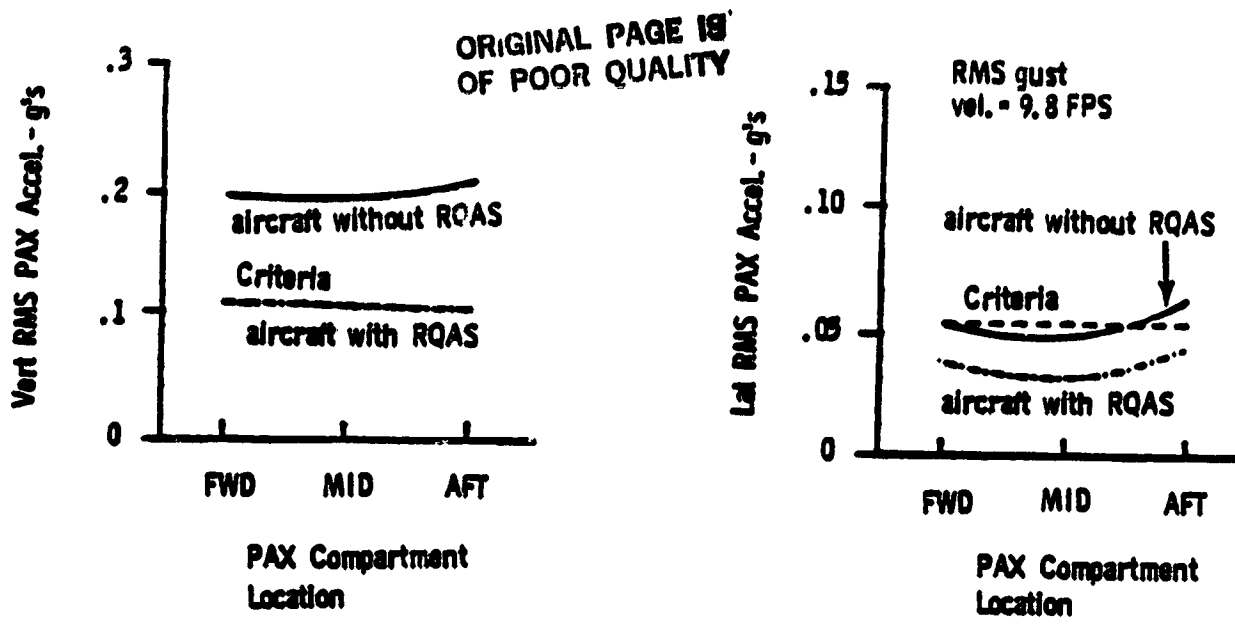

Figure 9. - Passenger Ride Quality During Approach.

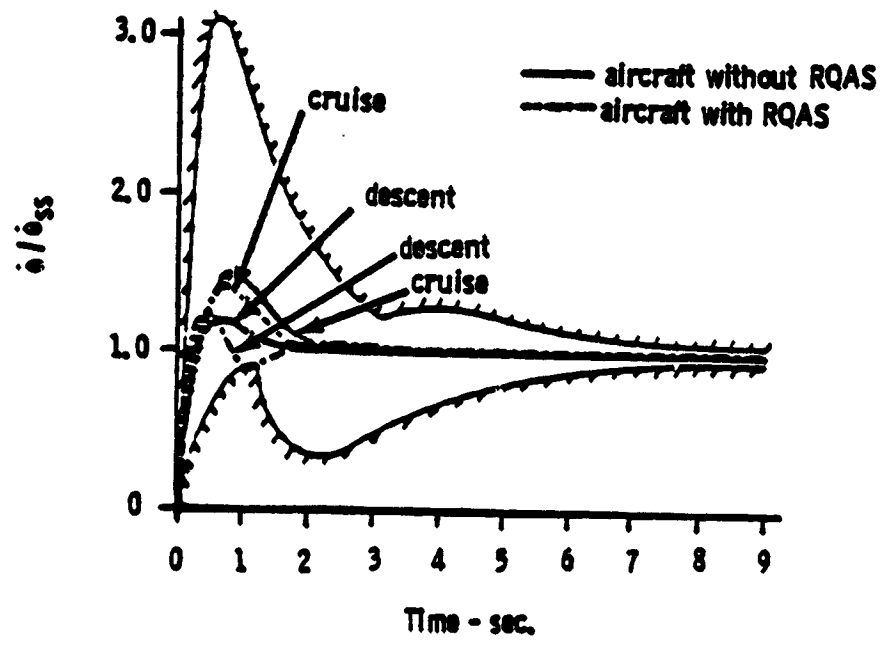

Figure 10. - Longitudinal Handling Qualities.

ORIGINAL PAGE 13
OF POOR QUALITY

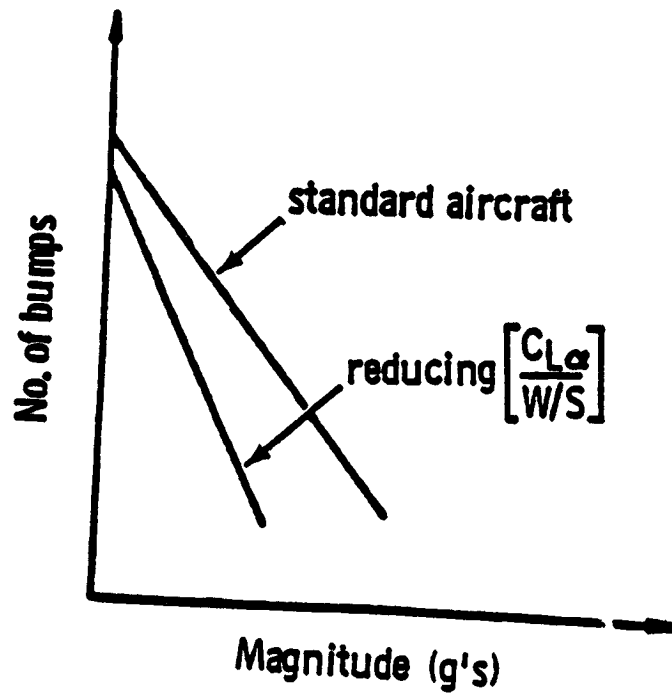
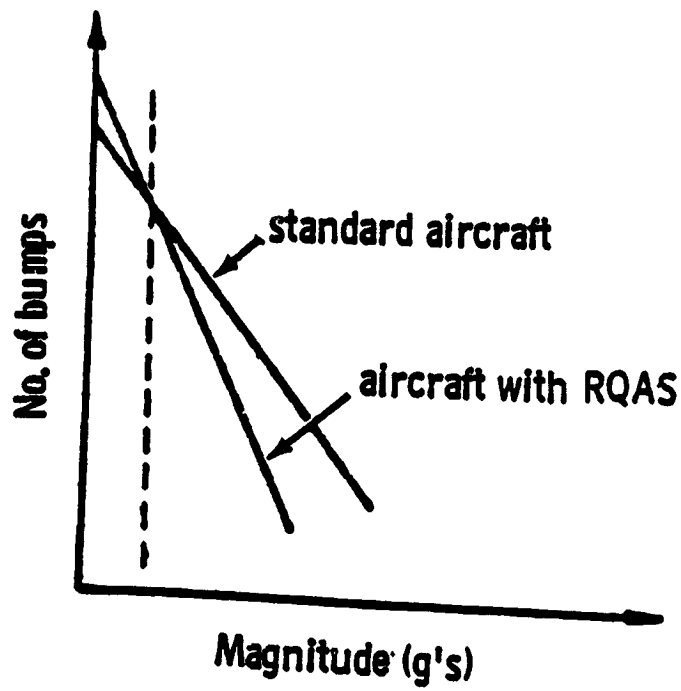

Figure 11. - Contrast Between Effects of $W/S/a$, and an Active RQAS.

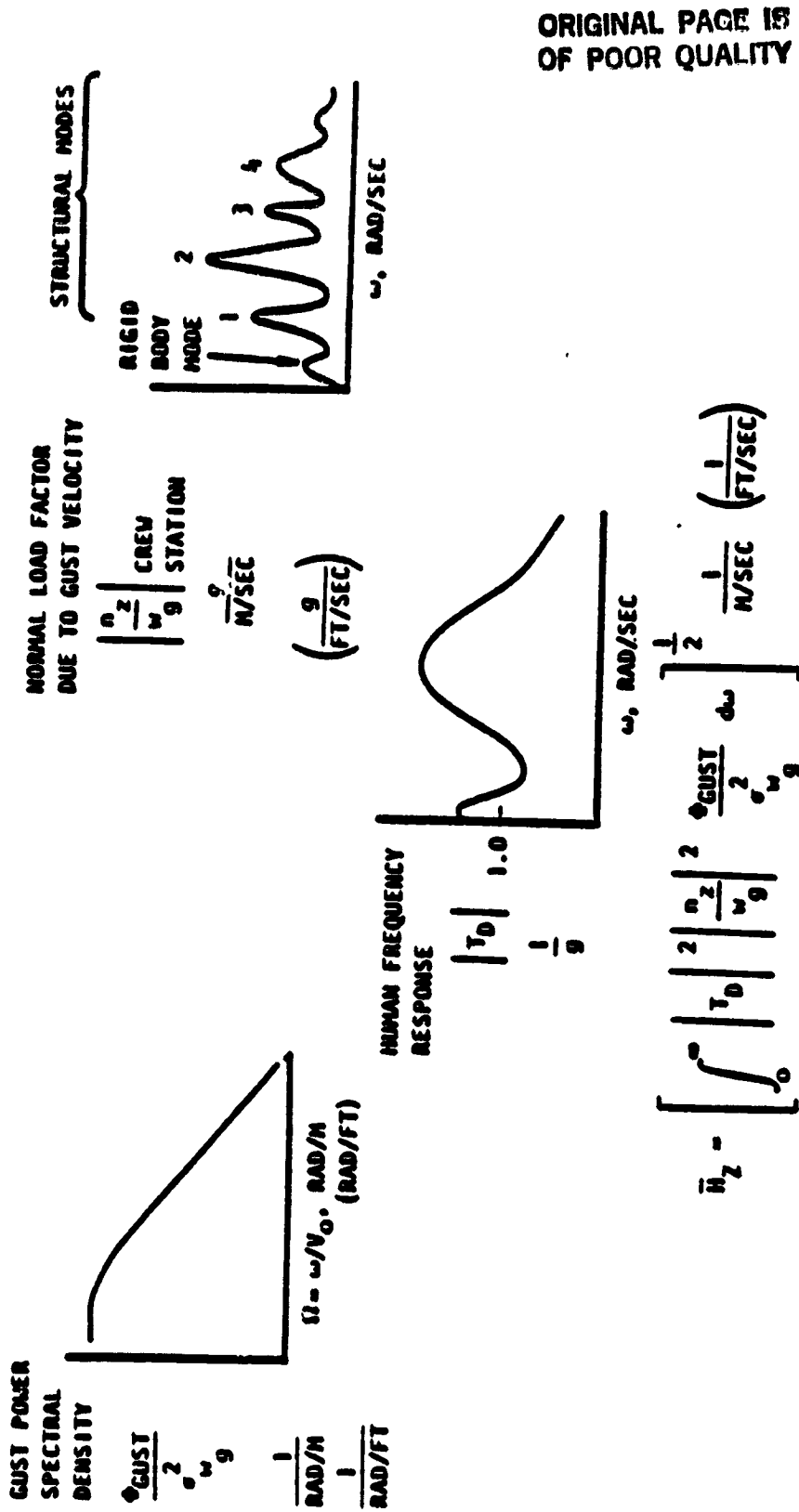

Figure 12. - Effect of Crew Sensitivity Index on Ride Quality.

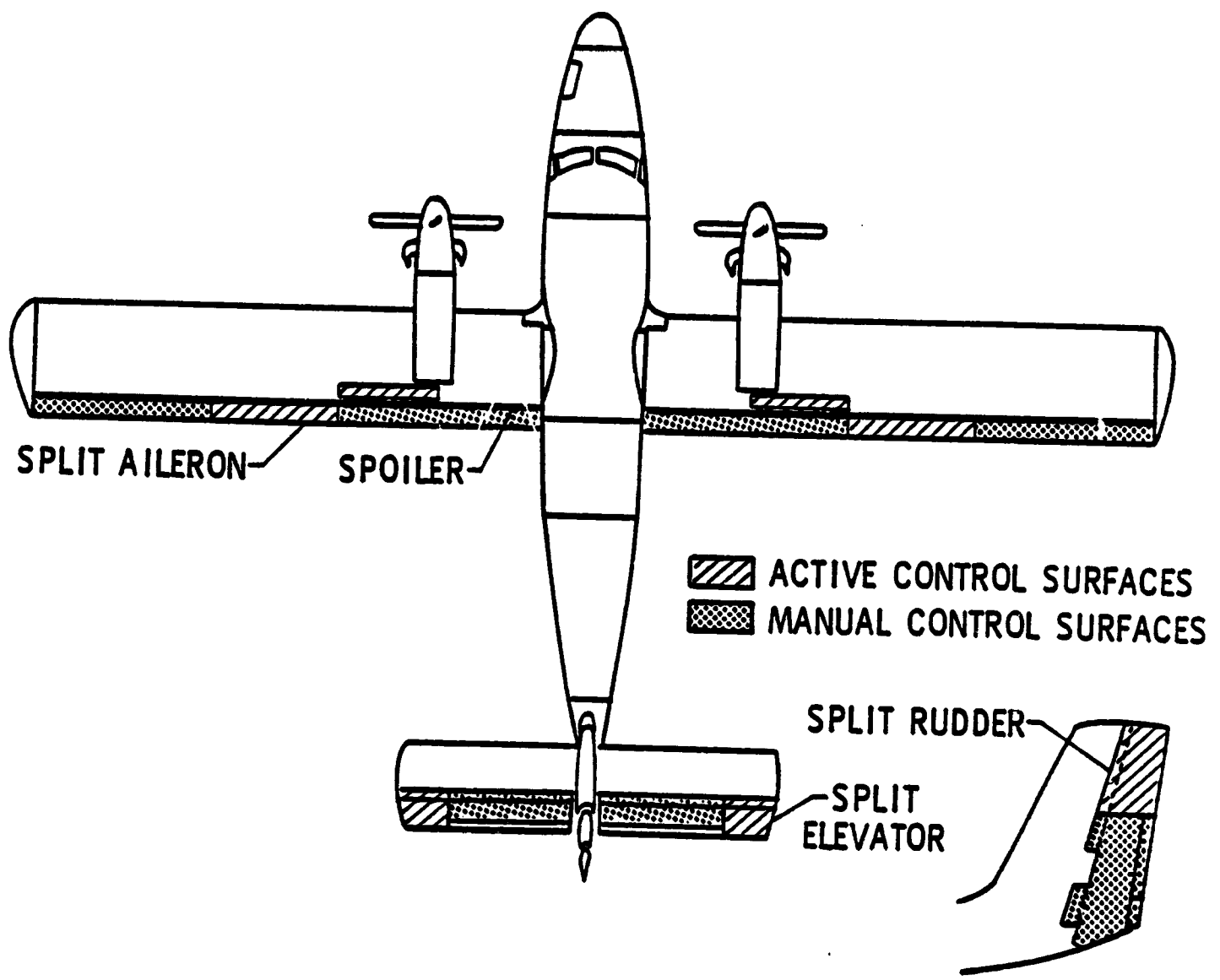

Figure 13. - RQAS Control Surfaces on the DHC-6 Study.

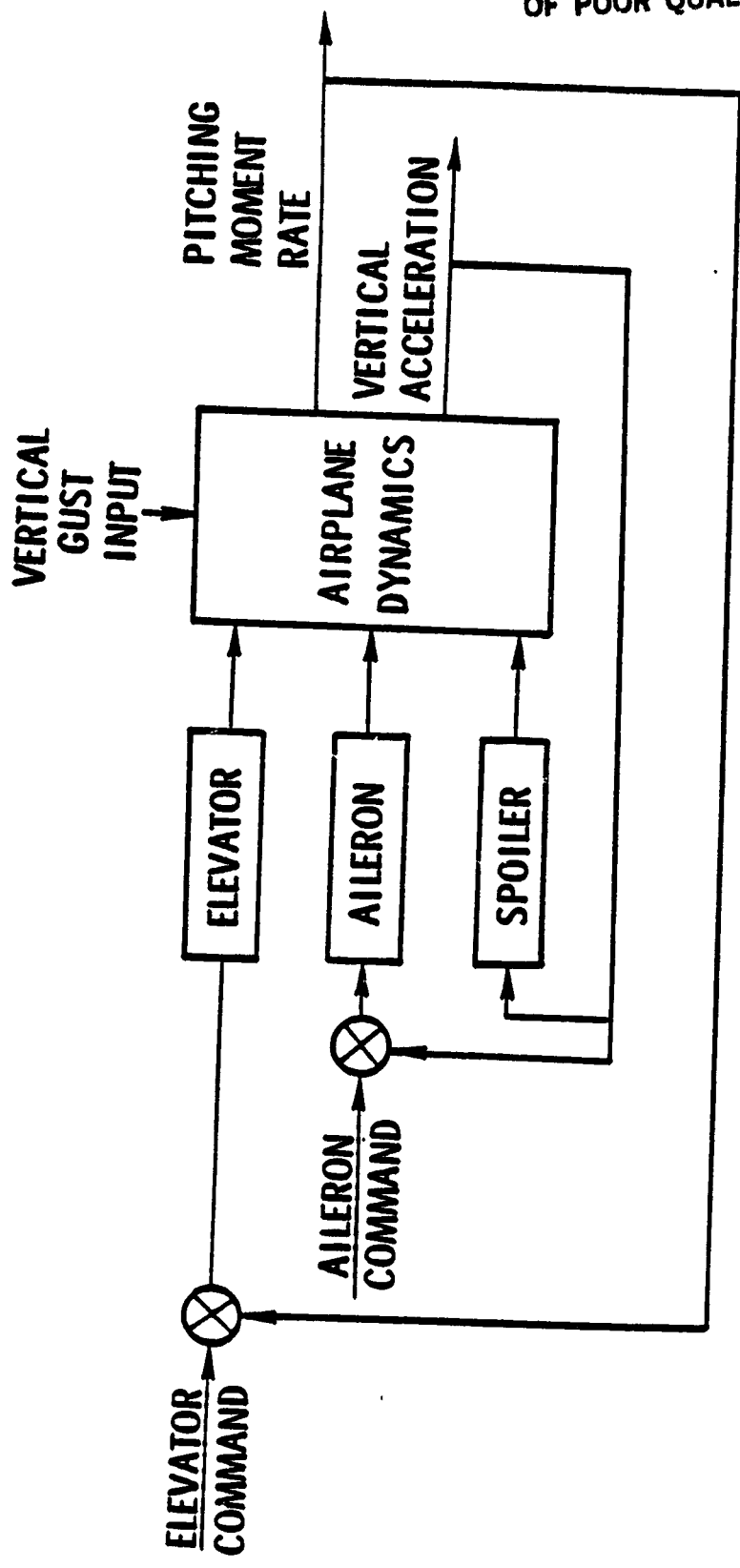

Figure 14 a. - Block Diagram of DHC-6 RQAS - Longitudinal Mode.

ORIGINAL PAGE 19
OF POOR QUALITY

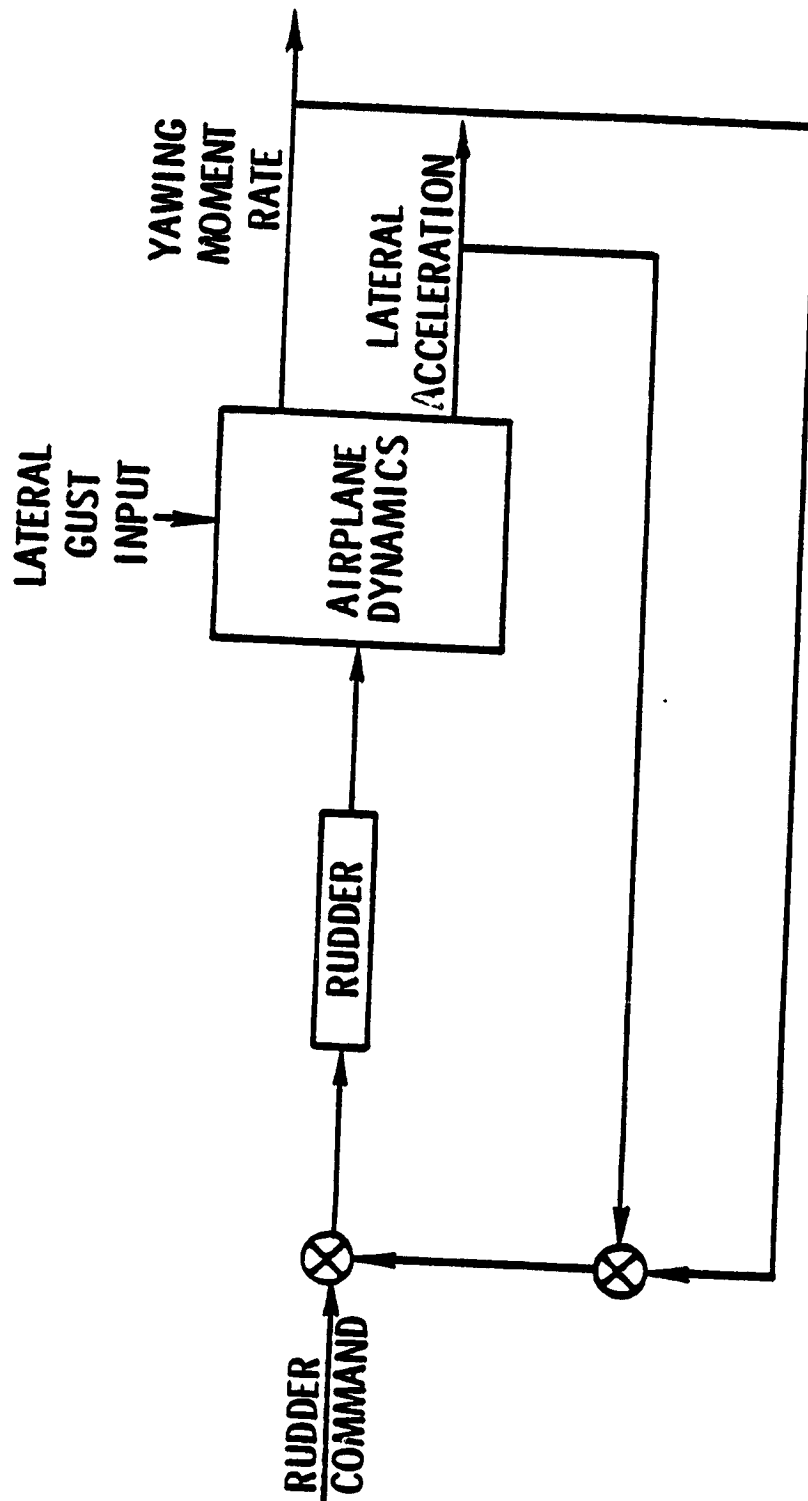

Figure 14 b. - Block Diagram of DHC-6 RQAS - Lateral Mode.

ORIGINAL PAGE IS
OF POOR QUALITY

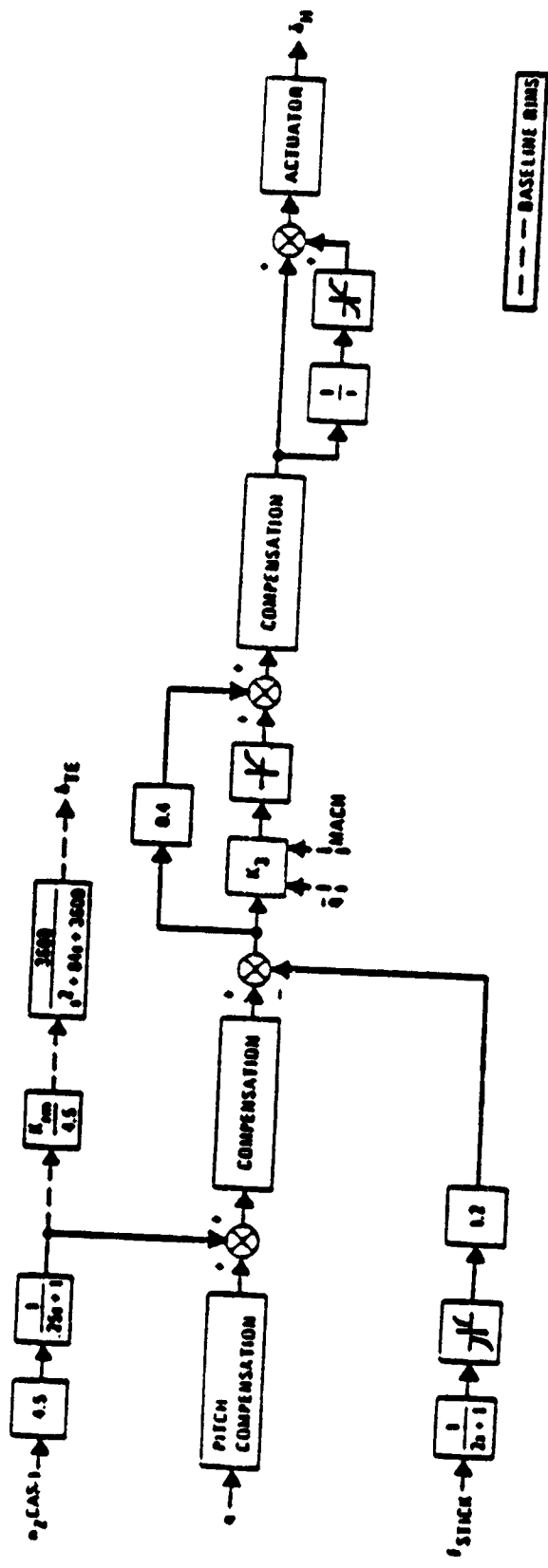

Figure 15. - Block Diagram of Longitudinal CAS with Baseline and Filtered RIMS (F-5).

ORIGINAL PAGE
OF POOR QUALITY

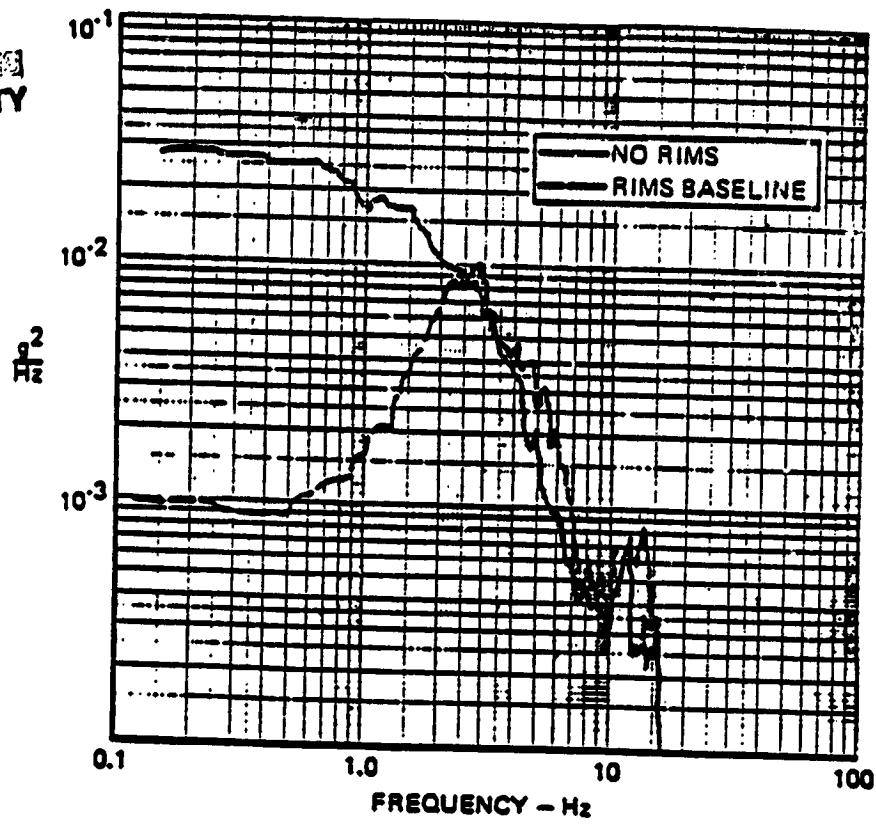

Figure 16. - PSD Response of Basic Aircraft and Baseline RIMS (F-5).

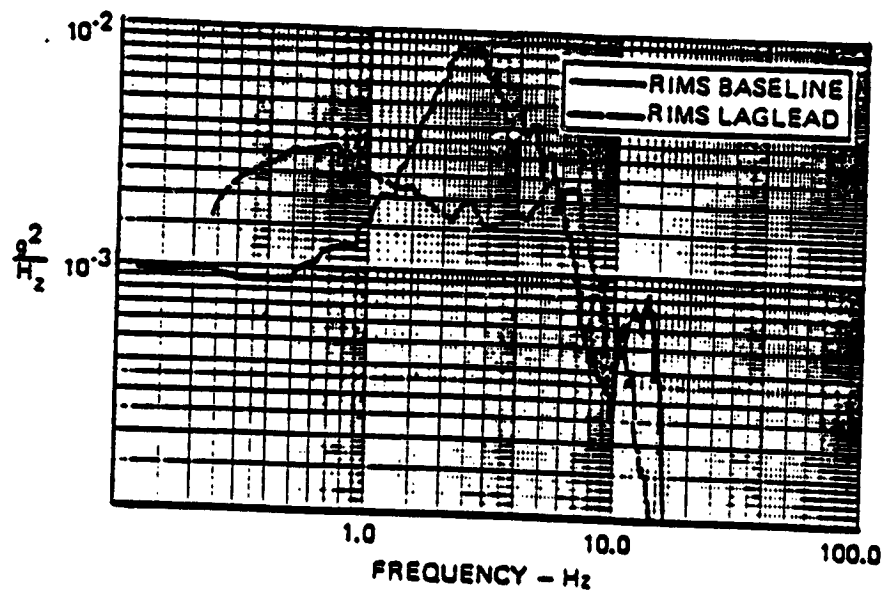
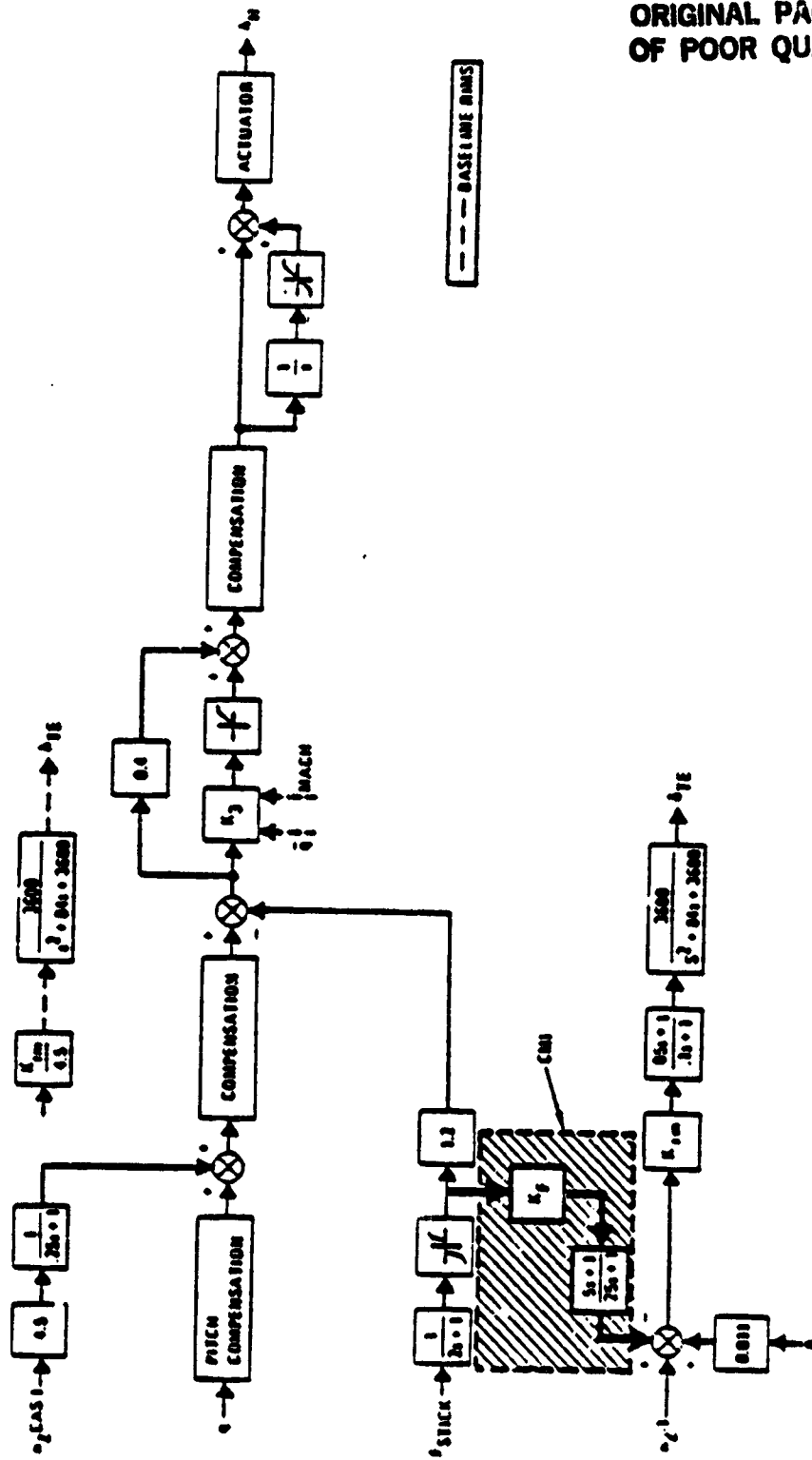

Figure 17. - PSD Response of Baseline and Filtered RIMS (F-5).



ORIGINAL PAGE IS
OF POOR QUALITY

Figure 18. - Block Diagram of RIMS with CMI (F-5).

ORIGINAL PAGE IS
OF POOR QUALITY

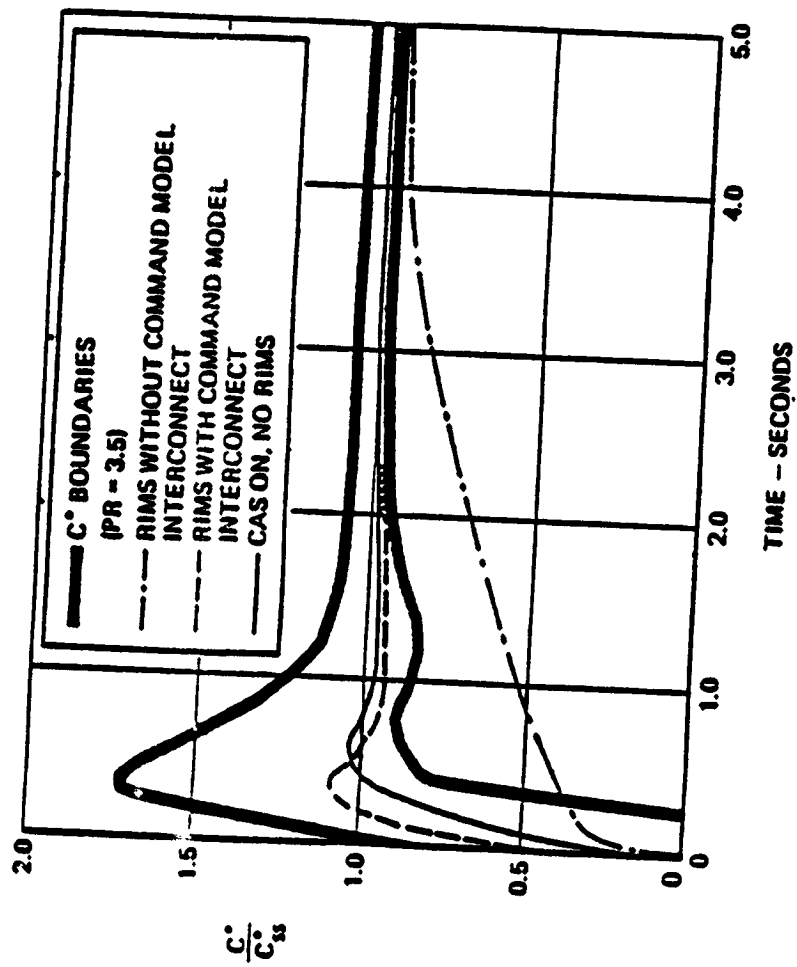

Figure 19. - C* Response for Basic F-5, with RIMS, and with RIMS/CMI.

ORIGINAL PAGE 19
OF POOR QUALITY

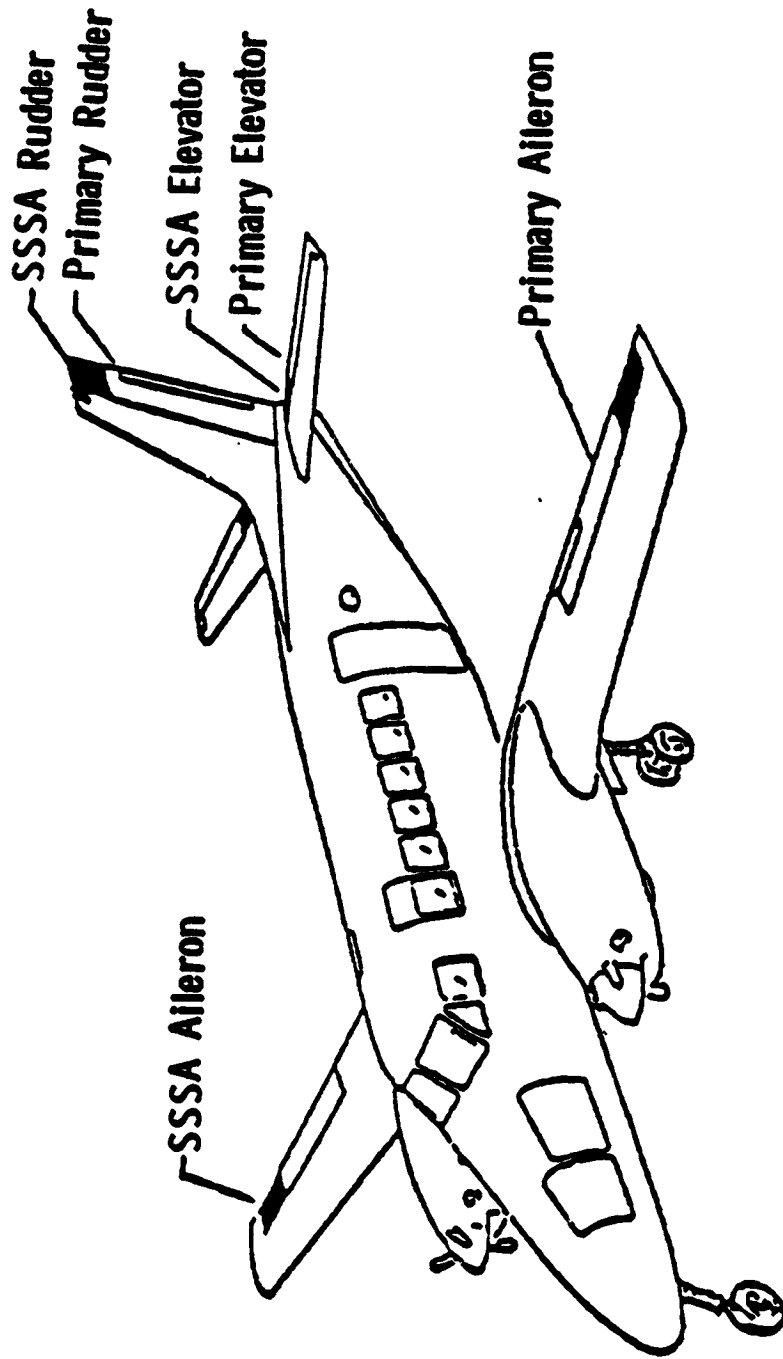

Figure 20. - SSSAS Test Aircraft

ORIGINAL PAGE IS
OF POOR QUALITY

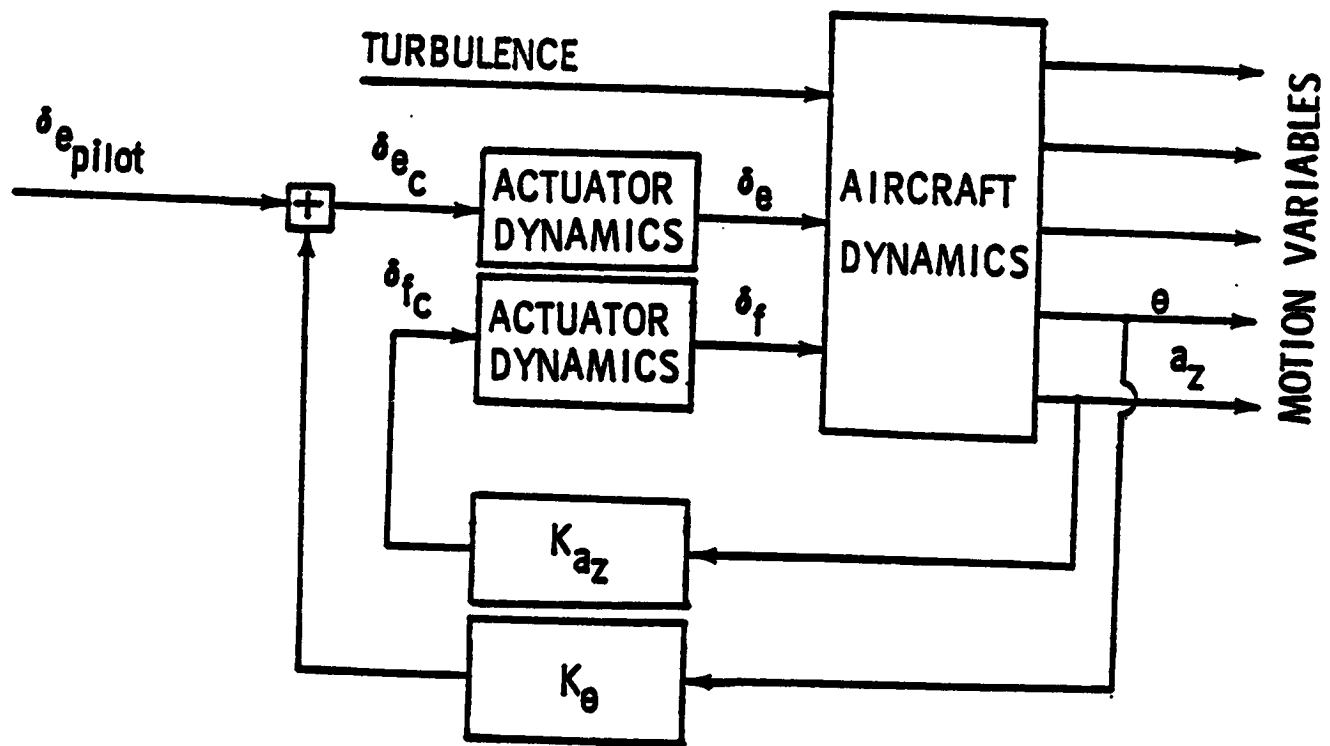

Figure 21. - Basic Longitudinal RQAS (GPAS).

ORIGINAL PAGE IS
OF POOR QUALITY

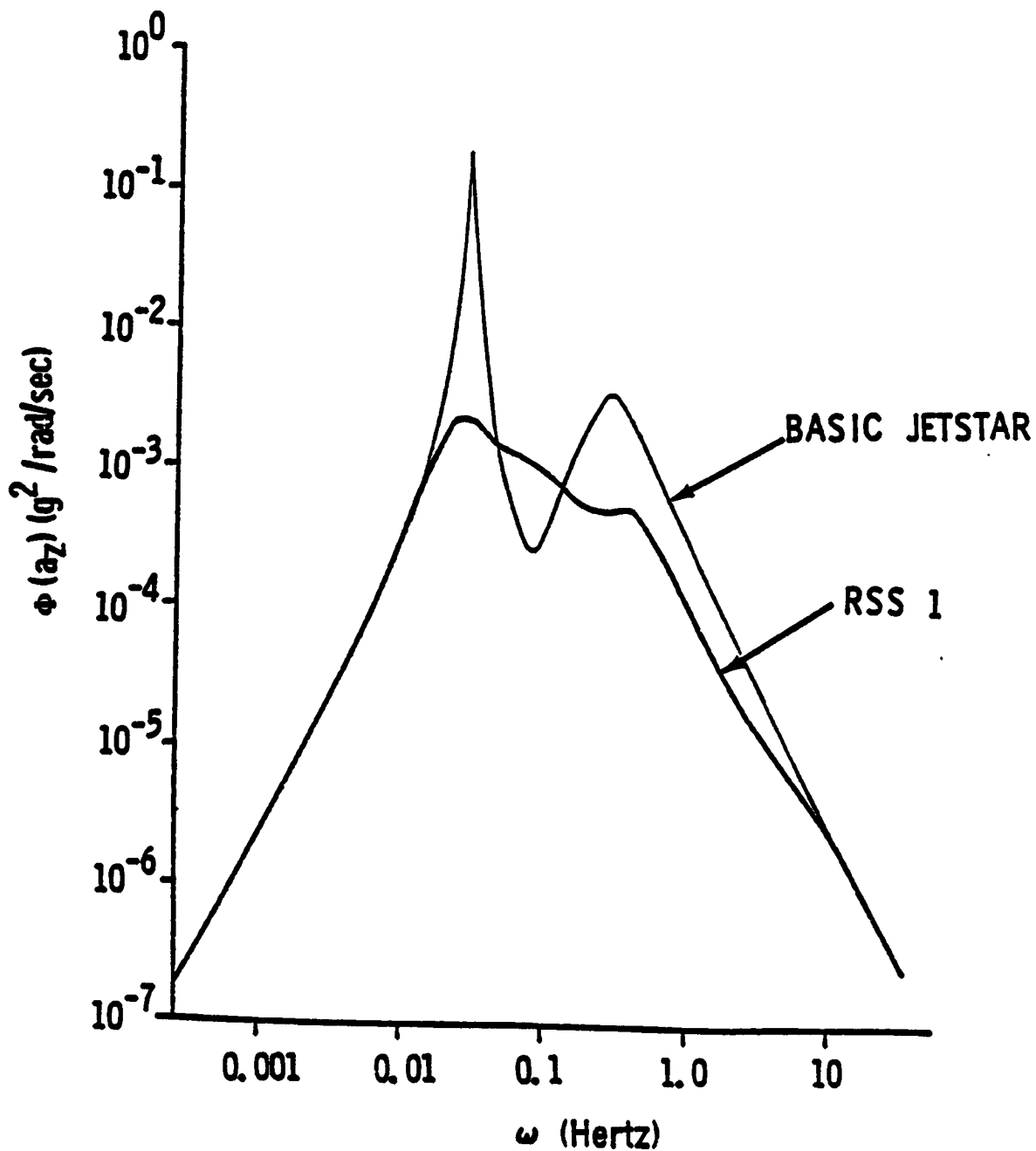

Figure 22. - PSD Response for RQAS 1.

ORIGINAL PAGE IS
OF POOR QUALITY

B
Y

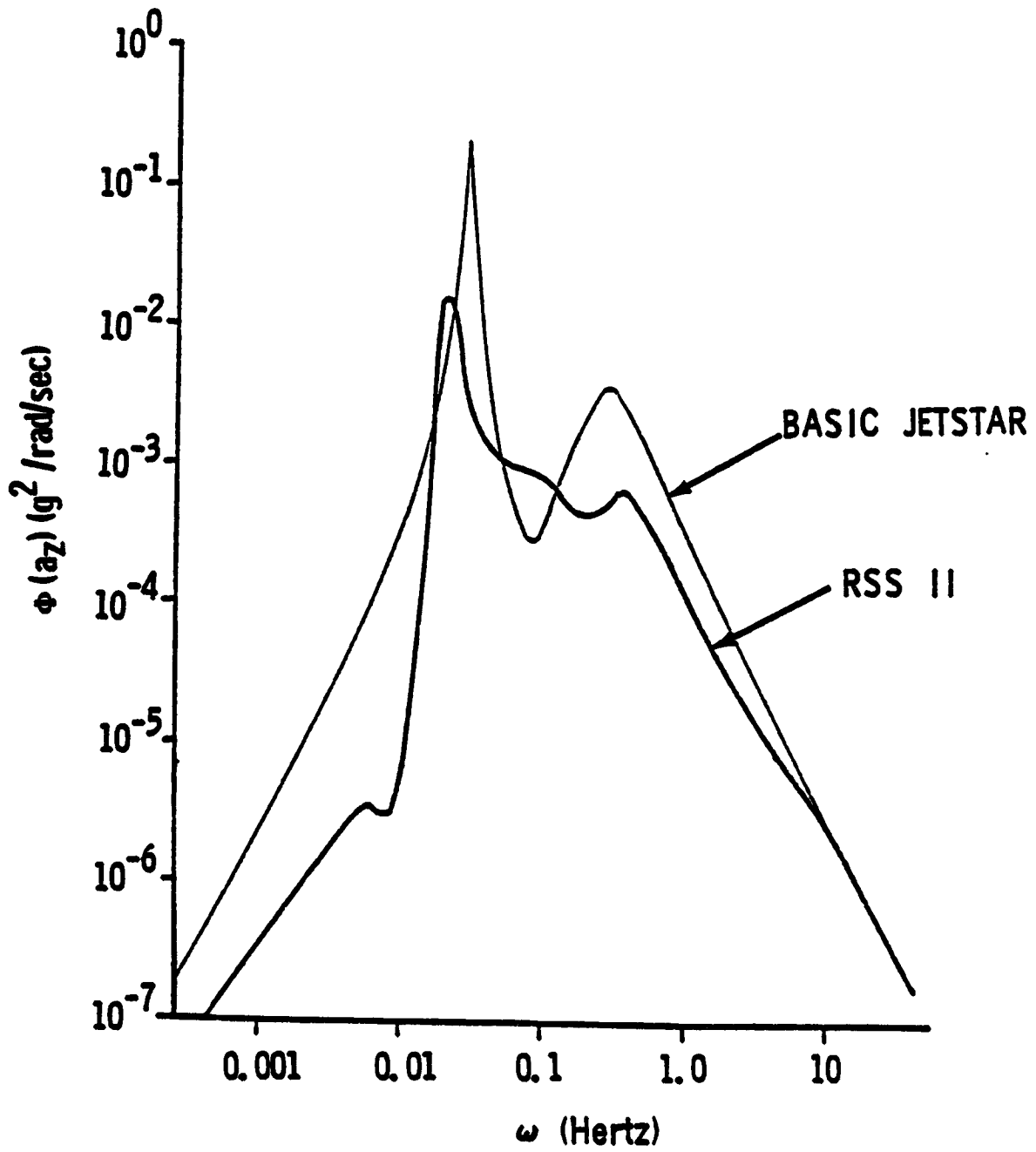

Figure 23. - PSD Response for RQAS II.

ORIGINAL PAGE IS
OF POOR QUALITY

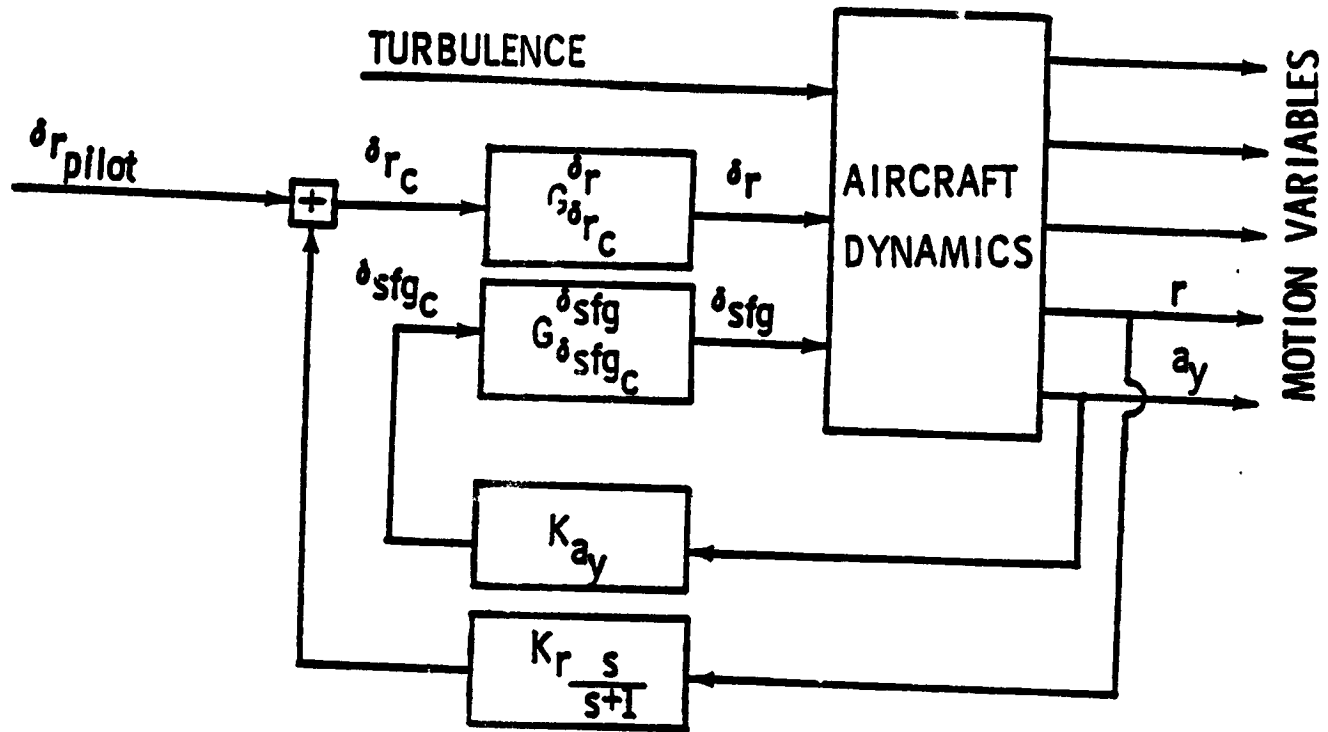

Figure 24 a. - Lateral RQAS Block Diagram.

ORIGINAL PAGE 11
OF POOR QUALITY

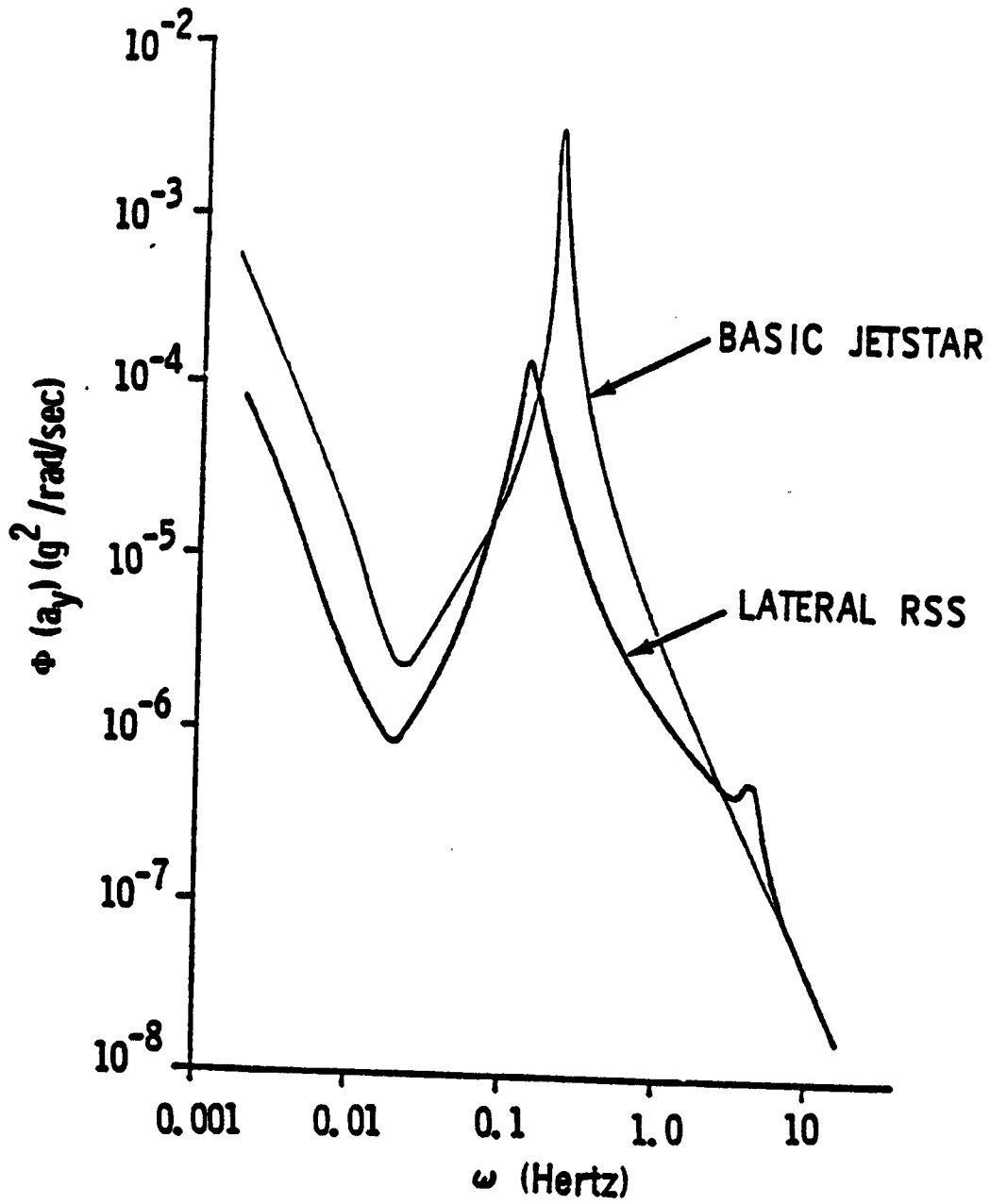

Figure 24 b. - PSD Response for Lateral RQAS.

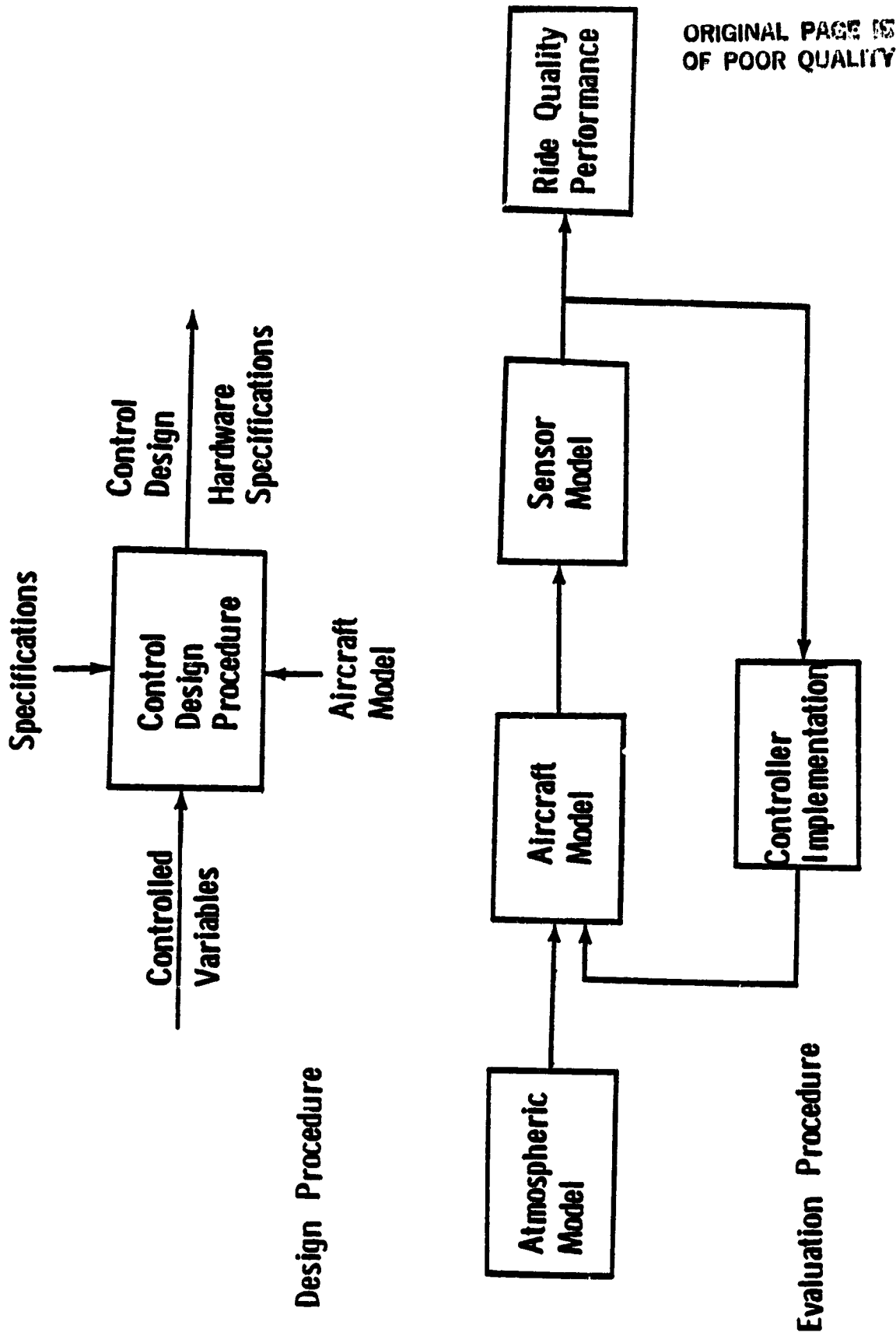

Figure 25. - RQAS Design and Evaluation Procedure.

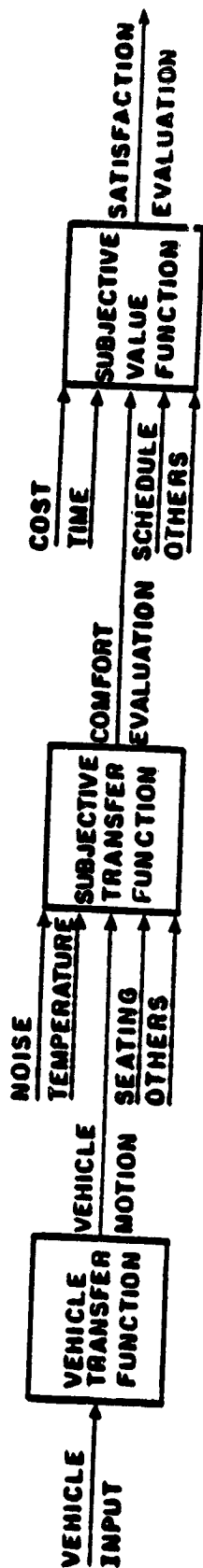

Figure 26. - The Ride Quality System.

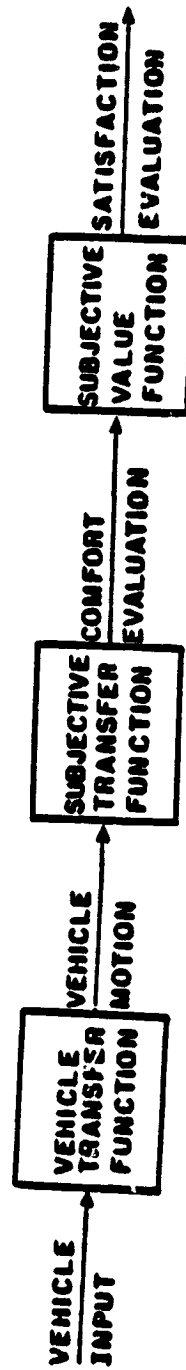

Figure 27. - Schematic for Determining Passenger Satisfaction with Ride.

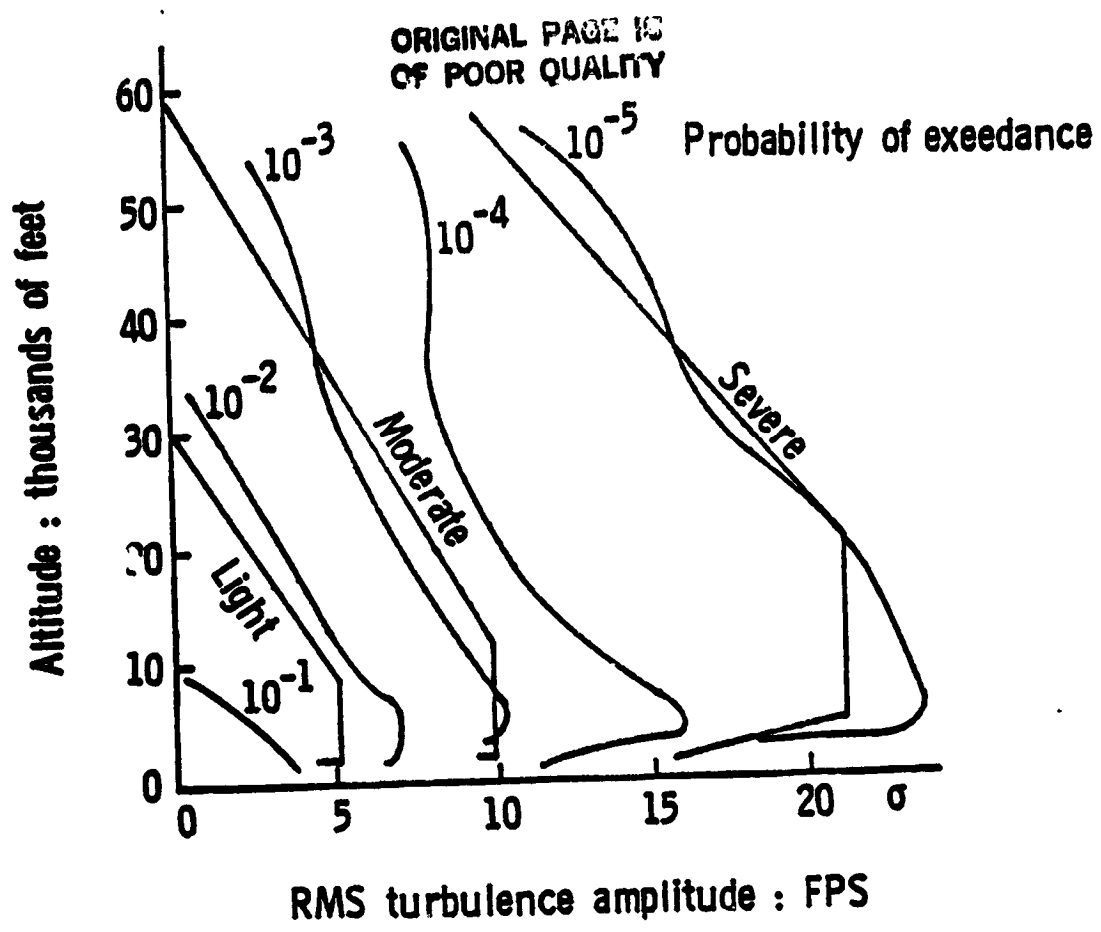

Figure 28. - Turbulence Exceedance Probability.

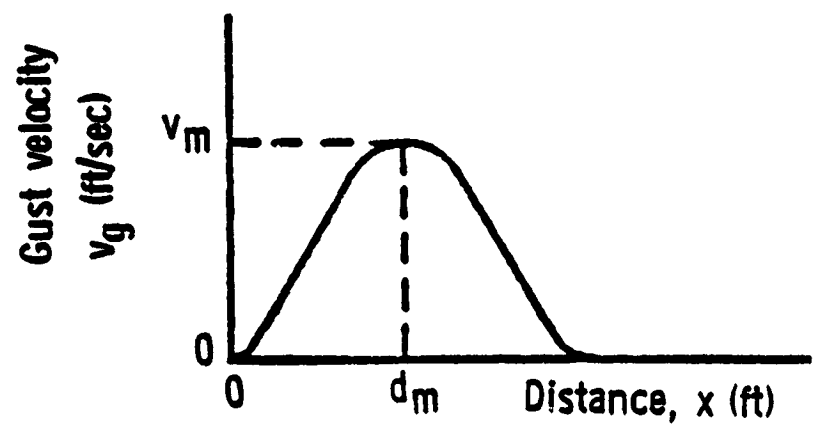

Figure 29. - Example of a 1-Cos Gust.

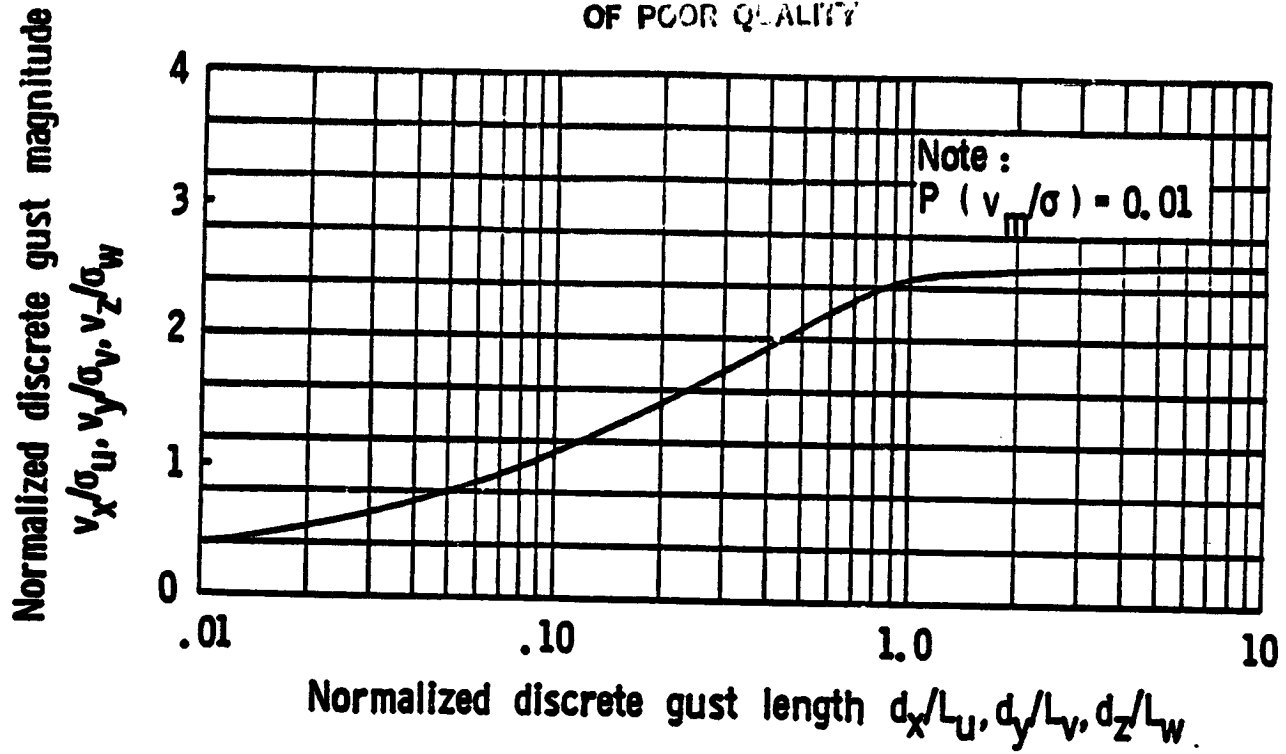

Figure 30. - Magnitude of Discrete Gusts.

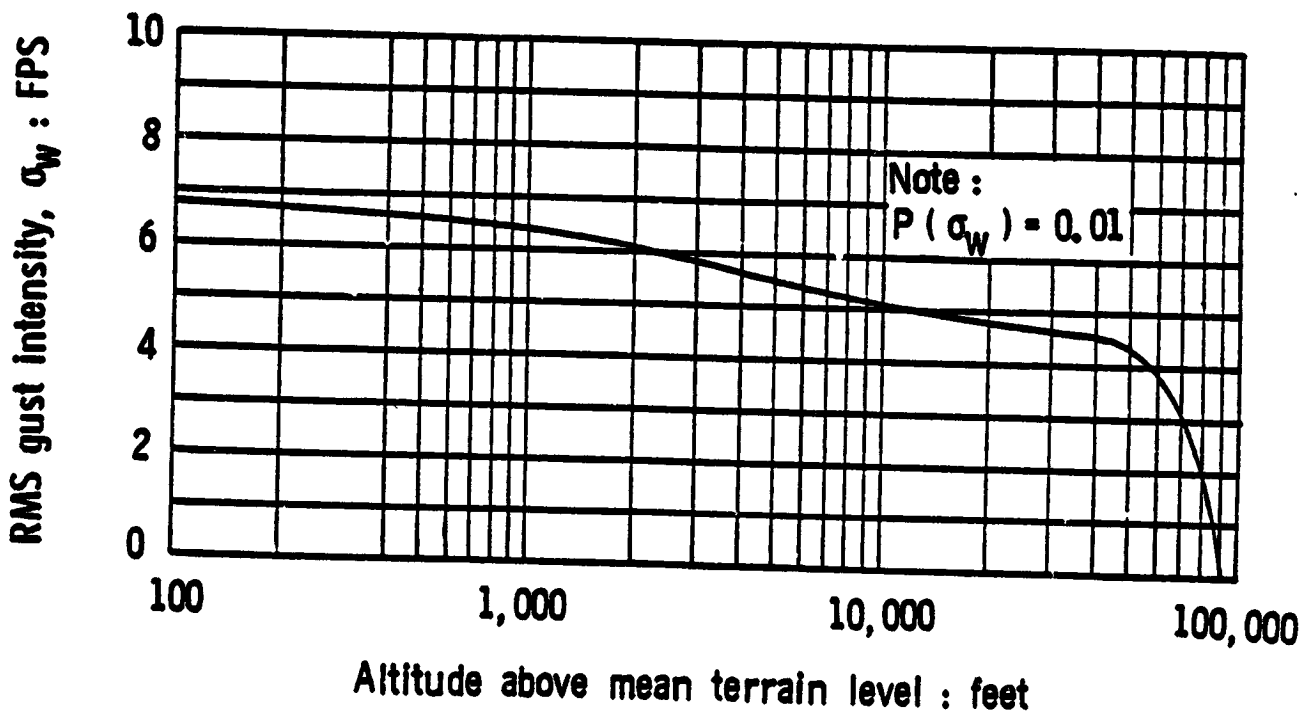

Figure 31. - Intensity for Clear Air Turbulence.

ORIGINAL PAGE IS
OF POOR QUALITY

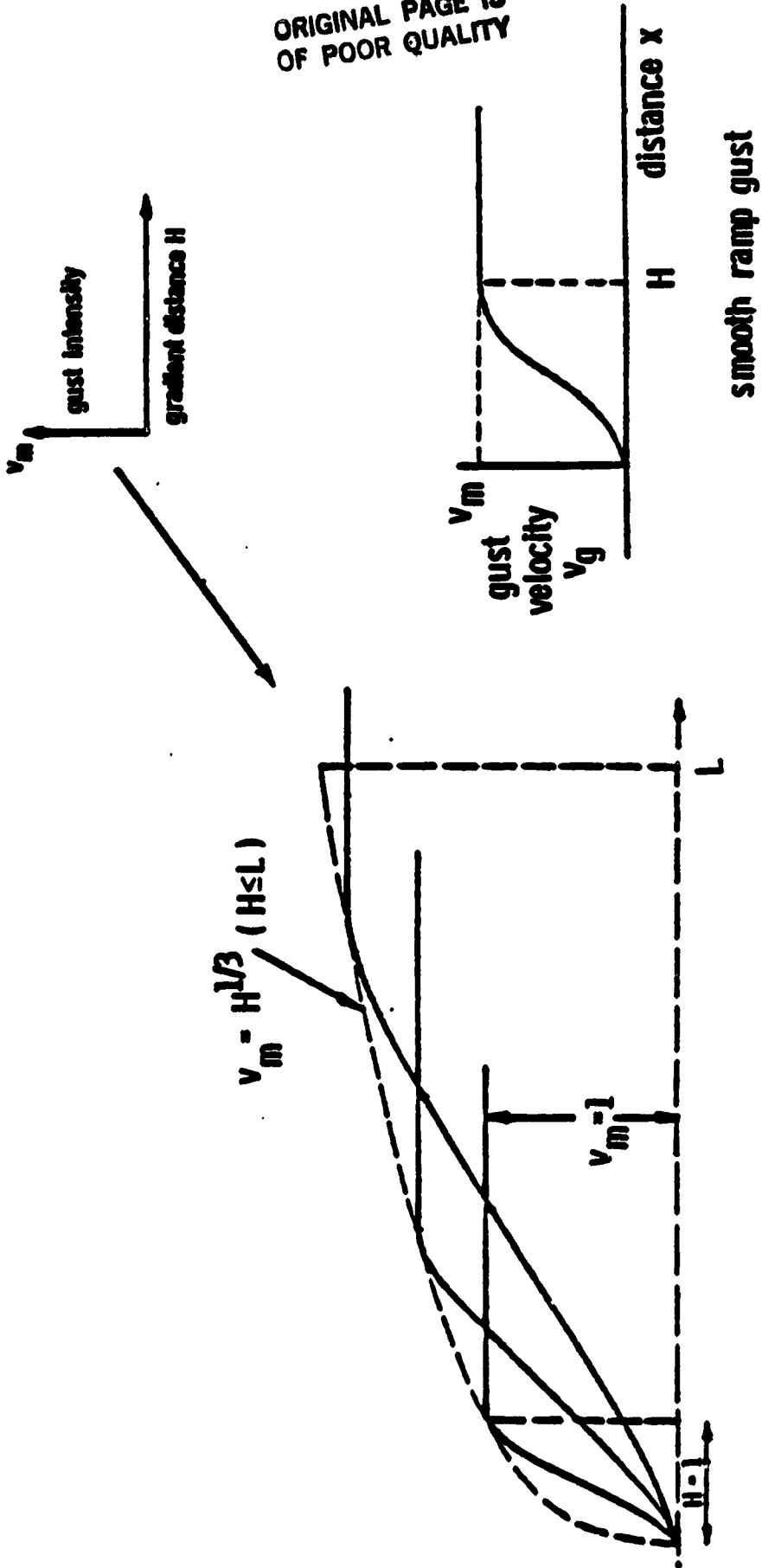

Figure 32. - Family of Equiprobable Ramp Gusts.

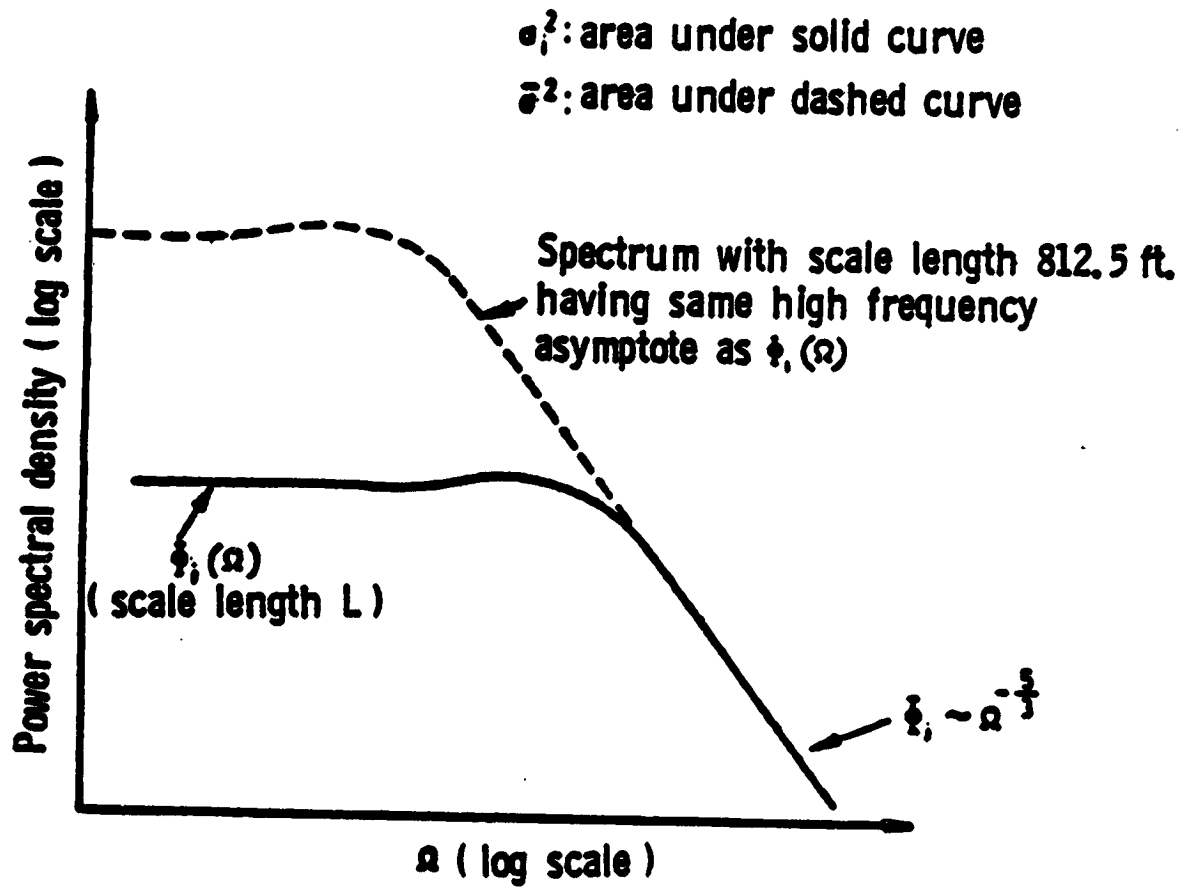

Figure 33. - Relationship Between PSD and Reference Intensity.

ORIGINAL PAGE 18
OF POOR QUALITY

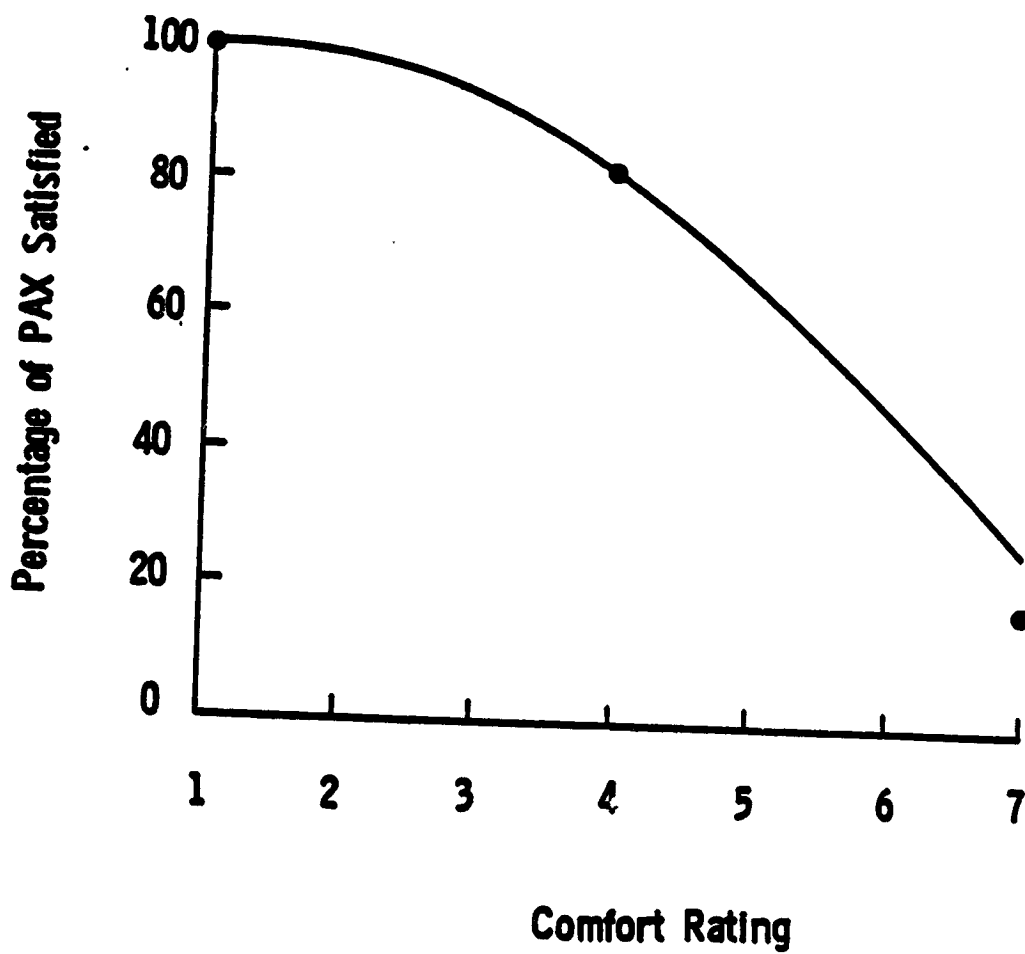

Figure 34. - Percentage of Passengers Satisfied as a Function of RQI.