

NASA Technical Memorandum 83064

Design Considerations for Large Space Electric Power Systems

(NASA-TM-83064) DESIGN CONSIDERATIONS FOR
LARGE SPACE ELECTRIC POWER SYSTEMS (NASA)
23 p HC A02/MF A01 CSCI 22B

N83-24552

Unclas
G3/20 C3754

**D. Renz, R. Finke, N Stevens,
J. Triner, and I. Hansen
Lewis Research Center
Cleveland, Ohio**



April 1983

NASA

DESIGN CONSIDERATIONS FOR LARGE SPACE ELECTRIC POWER SYSTEMS

David D. Renz, Robert C. Finke, N. John Stevens,
James E. Triner, and Irving G. Hansen

National Aeronautics and Space Administration
Lewis Research Center
Cleveland, Ohio 44135

SUMMARY

David D. Renz

NASA studies have projected that the power requirements of spacecraft will grow to the megawatt level by the year 2000. It becomes quickly apparent that the low-voltage, direct-current power systems currently in use cannot provide the power for these spacecraft. Ground-based industrial equipment is operated at various voltage levels (120, 240, 480, ..., 2400 V ac) depending on the kilovolt amperage required. Spacecraft power systems should be sized in a similar manner. The power systems should have the inherent flexibility to adapt to various power needs so that new technology need not be created for each mission.

Because of plasma interactions, especially in low Earth orbits, it may be necessary to operate the solar array at a lower than desired voltage. At these voltages the conductor weight of a megawatt power distribution system would be excessive. Also insulating the solar array to allow higher operating voltages may not be effective, but it is possible to insulate the rest of the power distribution system. A logical solution is to operate the solar array at voltages compatible with the environment and to distribute the power at voltages consistent with the loads. To do this, the solar array has to be decoupled from the distribution system. This could be done with a rotary transformer mounted as close to the solar array as possible.

The rotary transformer could be an integral part of a series-resonant converter, mounted on the solar array, which would convert the low dc voltage of the solar array to high voltage and high frequency for distribution. This high-frequency approach would reduce the magnetic and conductor weights as well as eliminate the need for slip rings and high-voltage, high-current dc switches.

The power could then be distributed in any desired method such as three-phase delta-delta. The transmission lines would be coaxial or triaxial cables designed for the specific voltage, current, and frequency needed to meet the load requirements. Most important would be the simple user interface such as a transformer or a magnetic coupler.

INTRODUCTION

Robert C. Finke

The solar power of all of the spacecraft NASA has launched has totaled less than 120 kW. Most spacecraft have averaged under 1 kW of total system power. As a consequence, power distribution has been a straightforward task. With compact spacecraft the distribution-system cable weight has been rela-

tively low in comparison with other system elements, allowing the proliferation of power distribution at low voltages (nominal 28 V).

With the advent of the space shuttle, we entered a new era of large, high-power spacecraft where the amounts of power and the transmission distances from source to load will dictate dramatic changes in the management and distribution of power. As large space structures distributing power to a variety of users become a reality, so will the necessity for a distribution system resembling that used by ground-based electric utility powerplants and for the same reasons - reliability and cost effectiveness.

To reduce the cost of interfacing equipment with the space system, the power system should be versatile and compatible with the needs of the users (i.e., a "user-friendly system"). The ultimate in user-friendly systems would be one that would be compatible with standard laboratory and industrial equipment.

The power losses in the distribution system can be minimized by distributing power at a voltage appropriate to the size of the load. Ground-based power systems have been designed this way for years. Common industrial equipment is operated at 120, 240, 480, 600, or 2400 V depending on the kilovolt amperage required. So also should spacecraft. If we truly anticipate that space power systems will grow to megawatt power levels, we should be very cautious about fixing a voltage level that may be inadequate to supply power to large loads.

At this time it is difficult to predict with any accuracy the future power needs of space systems. Projections of megawatt requirements by the year 2000 have been made. Some power loads, primarily military, with continuous power demands as high as 1 MW have been discussed. Power system concepts to support future requirements should have the inherent flexibility to be readily adaptable to various power needs so that new technology need not be created for each mission.

Solar-array power generation systems, by necessity, contain large areas of exposed conductor. Exposure of these conductors to the space plasma and subsequent interactions can influence power system operation (e.g., breakdowns to environment produce oscillations in output). Present knowledge indicates that plasma-induced breakdowns in low Earth orbits can start at array operating voltages as low as 300 V. Since array voltage is almost doubled when a spacecraft first comes out of eclipse, it may be necessary to design the array for nominal voltages as low as 150 V. A voltage level of 150 V is inconsistent with multihundred-kilowatt power distribution systems because of the excessive weight of copper conductor required.

Insulating the array from the environment to allow it to support higher voltages increases weight and may not offer immunity. However, higher voltages are possible for the rest of the power distribution system. A straightforward solution is to operate the array at voltages compatible with the environment and to distribute the power at voltage levels consistent with power demands and transmission distance. This requires decoupling the array from the distribution system. The most effective decoupling approach is to employ transformer isolation as close to the solar array as possible. The secondary can be sized to the voltage requirements of the various loads. Furthermore multiple voltage levels become feasible and desirable to supply varying loads. Once the concept of isolating the array from the rest of the system with a transformer is incorporated into the design, it becomes a simple matter to conceive an alternating-current distribution system. To summarize, for large power systems (>100 kW) that require multiple voltage levels for the many different loads found on large spacecraft, it becomes apparent that an

ac power system is a logical solution for power distribution. This report addresses the environmental interaction problem for spacecraft power systems and develops the concept of an ac power distribution system and its advantages.

ENVIRONMENTAL INTERACTION OF SPACE POWER SYSTEMS

N. John Stevens

Solar-array systems consist of strings of solar cells with metallic interconnections (fig. 1). These interconnections are at some voltage depending on their position in the array circuit and are usually exposed to the environment. When these systems are placed in orbit, the biased interconnections act as plasma probes and collect particles from the surrounding low-energy plasma environment. Because this plasma environment peaks at 300 km (fig. 2), the problem of particle collection is most serious there. The array will float at some potential relative to the space plasma potential so that the net current is zero (i.e., the electron current is equal to the ion current). Since electrons are more mobile than ions, the array potential will be predominantly negative to inhibit electron collection and enhance ion collection. This electron and ion collection by various parts of the generating circuit represents a current loop that is parasitic (i.e., it is a loss to the power system). As the operating voltages are increased, the collection losses will be larger. At voltages currently used (<100 V) the losses are negligible.

A simple approach to minimizing the interactions between high-voltage surfaces and charged-particle environments is to cover all of the surfaces and thus prevent all contact. However, tests have shown that pinholes in insulators over high-voltage surfaces can collect significant electron currents and furthermore that the current collected seems to be proportional to insulator area (ref. 1). Therefore the effect of dielectric covering could conceivably be lost simply by having imperfections in the dielectric.

Laboratory Test Results

Laboratory experiments have been conducted over the past several years on small solar-array segments exposed to low-energy plasma environments (fig. 3, refs. 1 to 8). The bias voltages are provided by external power supplies. The plasma is generated by using either argon or nitrogen gas.

When positive voltages are applied to the solar-cell segment, the electron currents collected are quite low and are proportional to the exposed interconnection areas (fig. 4). At bias voltages of 100 V electron current collection increases rapidly by orders of magnitude. Above the transition region the electron current collected is proportional to the voltage and the solar-cell segment area. This collection phenomenon is proportional to the plasma density increasing linearly. The transition voltage seems to be insensitive to the plasma density.

The panel goes into a breakdown mode at a plasma-density-dependent value. There is considerable scatter in determining the actual value, but a graph of breakdown voltage versus plasma density illustrates this trend (fig. 5). The curve is representative of the trend. Additional work over broader ranges of density needs to be conducted before a more definitive curve can be constructed. However, it is believed that when these breakdowns occur, space power system operations will be seriously disrupted.

Both electron and ion current collection phenomena observed in the laboratory simulations were reproduced in space on the Plasma Interactions Experiment (PIX) (refs. 9 and 10). This experiment operated in a 900-km polar orbit for 4 hr. The space data for the solar-array segment and dielectric-conductor experiment agreed very well with laboratory simulation data. The square symbol shown in figure 5 represents the breakdown threshold for the solar-array segment on PIX. Hence the phenomenon is not a laboratory peculiarity.

The laboratory results can be summarized in a voltage-current curve (fig. 6). This curve shows that for low values of positive and negative voltage there are minimal interactions. At larger negative voltages the panels can discharge and cause transient voltage pulses. At larger positive voltages the electron current collection becomes proportional to the panel area.

Application to Space Power Systems

As previously stated, solar-array space power systems must float electrically such that the net current collected from the environment is zero. This is most easily illustrated by considering an array with an operating voltage distributed linearly from tip to tip with positive and negative values (i.e., a center-tapped array). As a general guide this array will float in the charged-particle environment such that the voltage will be 10 percent of the operating voltage above space plasma potential and 90 percent below. For example, a system with an operating voltage of 1000 V (+500 V) will be +100 V and -900 V with respect to space plasma potential. Because computation of the floating voltage is not easy for an actual power system, the following discussion will be limited to general comments.

Those areas of the array that are positive with respect to space will collect electrons in much the same way as was done in laboratory simulations. At the higher plasma density conditions (low Earth orbit), it is probable that the operating voltage will stay at or below 1000 V. Under the simplified guideline for estimating voltages relative to space, this means that the maximum positive potential would be about 100 V, or just at the transition. Hence only a small area of the array would be capable of collecting electrons. Most of the electron collection would be at interconnections and would represent a low power loss. However, by the same guideline, the array would be at -900 V and discharging is very likely. This represents the present limit to high-voltage space power systems. Extrapolation of the breakdown voltage curve to 300-km orbits (plasma densities of 1×10^6 to $3 \times 10^6 \text{ cm}^{-3}$) indicates that breakdowns could be triggered at negative voltages slightly larger than -300 V. Hence it appears that, without additional effort to improve breakdown capabilities, high-voltage power systems in low Earth orbit would be limited to 300-V operation.

Other characteristics of power systems in low Earth orbit should also be considered. The system will undergo an eclipse in each orbit. This will require that the system be shut down before the eclipse. During the eclipse the array will cool down so that, when it returns to sunlight, it could be at twice the normal operating voltage. For the preceding example the nominal 300-V array would enter sunlight cold and generate about 600 V. Again, the approximate -540-V negative side could discharge and produce transients. The array would rapidly heat up and return to its nominal operating voltage. But at each entry into sunlight on each orbit, discharge transients could be

expected. If 300-V operation of the array is needed as a normal condition, it may be necessary to short the array immediately after eclipse during array warmup.

Concluding Remarks

Space power systems, operating at high voltages, have been proposed for multikilowatt capabilities at orbits ranging from space shuttle altitudes to geosynchronous. For solar photovoltaic systems the exposed interconnections can interact with the charged-particle space environment in a manner that can influence the power system performance. These interactions are more severe at the lower altitudes.

The concept of plasma drain currents has been known and discussed for years. Laboratory testing of small solar-array segments has supplied data that can be used to develop empirical relationships for computing this loss. However, the real limiting factor to use of high voltage in these power systems is the probability of breakdown at negative voltages. This occurs because of the strong electric field confinement in the gaps between the solar cells.

Basic operations of the power system in low Earth orbit can also be influenced by the variation of environmental conditions that will exist over the orbit. The eclipse will shut down and cool off the power system. This means that the array will enter sunlight at an even higher voltage. To reduce breakdowns by using current technology, the solar arrays should be limited to 300 V. Because of the voltage doubling when the solar array comes out of an eclipse, either a 150- to 180-V operating range or array shorting during warmup may be required.

DISTRIBUTION TECHNOLOGY

James E. Triner

Low-power (<10 kW) spacecraft power distribution systems have supplied direct-current power to "dedicated" loads with either regulated or unregulated dc power buses. With requirements emerging for higher power (100 kW to 1 MW) and variable load (frequency, voltage, and power) conditions, conventional low-voltage, high-current dc distribution systems must eventually give way to high-frequency ac distribution systems.

Future high-power space distribution systems will not be point-to-point interconnections to predetermined dedicated loads. The system will emerge as a multiterminal network with the ability to supply or accept power at various voltage, frequency, and power levels. Multiterminal dc networks (ref. 11) are not suitable for small taps (less than 20 percent of system rating) because a small tap is very susceptible to system faults, especially to disturbances on its own bus. This might cause commutation failure, recovery from which may be difficult and may even require a momentary shutdown. Other faults such as a short circuit would be extremely difficult to interrupt on a dc distribution bus. In addition, all tap-switching elements must be rated for the full distribution voltage.

These major design problems with an all-dc distribution system make it impossible to consider this approach for future high-power spacecraft distri-

bution systems. However, the advantages of high-frequency ac systems allow reasonable solutions to these problems. In addition, a high-frequency ac system would be much more stable than current terrestrial low-frequency ac distribution systems.

In terrestrial power systems, frequency is closely related to the real power balance in the overall network (ref. 12). The load-frequency inter-relationship constitutes one of the most important phenomena in the power system. For a stable transmission system the system generators run synchronously and generate the power that is being drawn by all loads plus the real transmission losses. The transmission losses consist of the ohmic losses of the transmission components, corona losses on the lines (in high-voltage systems), and the core losses associated with transformers and generators. Load variations will always be present and cause deficiencies or surpluses of electric power and consequently frequency fluctuations. Once the speed of the generator has been locked to the rest of the system, the control of real power generation is achieved by controlling the torque of the prime mover.

The primary power "generator" proposed for the space platform transmission system is a solid-state series resonant converter (ref. 13). The characteristics of this type of generator are significantly different from those of conventional rotary power devices. The resonant tank circuit frequency and damping coefficients will vary with the reactive effects and the resistive loading, respectively. Duty-cycle control algorithms involving preregulation or repetition rate of the resonant circuit will have to be developed for controlling the transmission-line voltage. This voltage must be adaptable to the varying line frequency and attendant harmonics that will be present in this control scheme.

A spacecraft electric power system is never as simple as a solar array, energy storage system, line regulator, and distribution system. Even the smallest space power system consists of an electrical network of vast complexity. One factor that determines the system architecture more than any other is system size. With low-power spacecraft dc-to-dc power conversion was ample to achieve the desired mission power requirements with a minimum of power-processing overhead. As space power requirements grow, the power distribution system must be compatible with future needs and power-processing technology.

In terrestrial power systems the use of dc-versus-ac power has been argued since the 1800's. However, three-phase alternating current has dominated the scene since that time. Direct current has some inherent advantages (e.g., low transmission losses) that make it the ideal transmission medium in certain instances. The major advantages to alternating current are that it is easily generated by using series-resonant or high-speed generator techniques; it is conveniently transformed to various voltage levels and frequencies; and it allows the use of inexpensive, lightweight, and effective primary power equipment (motors, transformers, etc.).

The desirability of operating the solar array at less than 300 V is discussed in the preceding section ENVIRONMENTAL INTERACTION OF SPACE POWER SYSTEMS. Decoupling the solar array from the rest of the power system with transformers and the ability to supply power at different voltage levels (both higher and lower than 300 V) (ref. 14) are the major features of the ac spacecraft power system shown in figure 7. Decoupling not only leads to a high degree of isolation, but allows the power system to be divided into four distinct levels:

(1) The conversion level (discussed in the section POWER CONVERSION).

(2) Transmission level - This level handles the largest block of power and interconnects all of the power sources (solar cell, batteries, thermonuclear generators, etc.) and all of the major loading points in the system. The system can supply or sink electric power to or from power systems connected to the network. The structure of the system at this level tends to be a loop structure rather than the radial structure that is typical at the sub-transmission and distribution levels.

(3) Subtransmission level - This level distributes power to heaters and large motors. Space manufacturing processes requiring "bulk power" would be supplied directly from the subtransmission system. Since this would be a high-frequency ac distribution system, radiofrequency heating furnaces could use this power without the weight penalty of additional power-conditioning equipment.

(4) Distribution level - This level consists of the smallest meshes in the overall space power network. Generally two voltage levels are used: for ground-based use the primary or "feeder" voltage is 2400 V ac and the secondary or user voltages are 120, 240, or 480 V ac. At this level ground-fault circuit protection can be used in power circuits; they would be easily accessible to personnel onboard a spacecraft. Also, new interface concepts such as magnetic couplers (i.e., matching magnetic core halves used as connectors) can be used to magnetically couple energy from or to the distribution system.

Very high-power spacecraft, such as those in the multimegawatt range, would perhaps require the full range of multiple voltage levels, including conversion, transmission, subtransmission, and distribution voltages. For medium-powered spacecraft, probably those in the less-than-1-MW range, three levels would be enough (conversion, transmission, and distribution).

Preliminary computer studies for typical 50-m-long coaxial cables have been performed. The characteristics of a cable with an internal conductor radius of 30 mm rated at 1000 V, 100 A, and 20 kHz are shown on table I.

A major advantage of an ac distribution system is the ease with which power can be transferred from the power system to the load or "user." By using transformers the voltage can be stepped up or down as required by the user. This method also provides isolation between the user and the power system. Another method that would provide the same advantages would be a magnetic coupler. Here the user would provide the secondary, which would be part of the load, and connect this to the primary, which would be part of the distribution system.

POWER CONVERSION

Irving G. Hansen

System Rationale

The system to be described is a multiphase, ac (sinusoidal), high-frequency (multikilohertz) power distribution and control system. The central concept of this system is a self-commutated resonant power conversion stage (fig. 8). This stage has the following advantages:

- (1) Versatile (user friendly)
- (2) Output tailored to load requirements (voltage and frequency)
- (3) Minimum radiofrequency interference problems
- (4) Simple rectification and filtering
- (5) No technology limit for power
- (6) Simple fault protection and isolation
- (7) System voltage not constrained by array or batteries
- (8) No switch loss at turnoff
- (9) Efficient voltage level conversion
- (10) Multiphase coaxial distribution, minimizing magnetic forces on structure
- (11) Rotary transformers, simplifying power transmission
- (12) High-frequency sinusoidal system, minimizing equipment mass

This system is inherently user friendly by virtue of its great versatility, which is due not only to ease of ac voltage level conversion or isolation but also to advanced power converter techniques that allow frequency and power waveforms to be tailored to the load requirements. The versatility of the system translates directly into minimum user interface circuitry with its attendant cost, weight, and other problems.

From a system point of view, three-phase triaxial-cabled sinusoidal power distribution minimizes both the electromagnetic interference and magnetic structural forces attendant on a lightly built, high-power space structure. Use of a delta-connected system provides redundancy, and feedback techniques have been demonstrated that insure line stability. Power transmission between the solar array and the loads can be accomplished with rotary transformers, thus relieving the distribution system of voltage constraints dictated by any one system component. For example, because the optimum solar-array voltage for a given system power and array configuration is not necessarily the optimum voltage for battery charging, any necessary adjustment of voltage can be accomplished by the associated transformers. Rotary transformers can be used instead of slip rings with their historic problems of wear, contamination, and voltage breakdown.

Resonant Power Converter

The basic concept of the resonant power converter is shown in figure 8(a). Switches 1 and 2 are alternately switched in such a manner as to present the series LC circuit with square-wave voltage. The LC circuitry, performing the function of a low-pass filter, allows only the fundamental (sinusoidal) current to flow in the series circuit. This characteristic is more easily seen by inspecting the equivalent circuit (fig. 8(b)). Note that in this configuration the load is placed across the capacitor and thus provides a low-impedance sinusoidal voltage source. Returning to figure 8(a), since the current into the capacitor is sinusoidal, the switch can be opened as the current passes through zero. Zero-crossing switching yields an advantage that cannot be overemphasized (ref. 15).

A major advantage of resonant power conversion is the lack of energy loss during power switch turnoff. Not only do the switches self-commutate, but also there is no frequency-proportional system power loss. As a result, power devices can be safely and efficiently operated at power and frequency levels

unobtainable by other conversion techniques (ref. 16). This high-frequency operation translates directly into lower system mass.

Operation of the power system at high carrier frequency also results in low-system-mass rectifier and filter circuitry for dc loads. Available lower frequency waveforms can be synthesized from this high-frequency carrier as required to satisfy user demands. A basic circuitry connection to allow this is shown in figure 9. In this circuit, switch pairs 1,1' and 2,2' are operated in such a manner as to perform synchronous rectification of the carrier and thus synthesize a lower frequency output. In this respect the circuit operates somewhat as a conventional cycloconverter. Proper sequencing of the switch pairs will also allow reverse power flow by chopping a lower frequency (including dc) into a higher carrier frequency.

The inherent symmetry of the high-frequency inversion system is illustrated in the bidirectional implementation shown in figure 10. The remarkable system versatility is exploited by this configuration, which transforms ac or dc into either ac or dc while allowing power flow in either direction. In particular this may be considered as a universal interface between storage, generation, transmission, and user (ref. 17).

It is in fault protection and load switching that an ac distribution system displays particular merit. Because the ac waveform is self-commutating, current interruption is simplified. Additionally in a resonant power converter the energy available to circuit faults is limited to only the energy stored in the reactive elements. Because of the high operating frequency the available fault energy is minimized.

A complete set of ac high-frequency system components together with their technologies is available to construct a single power system of at least 50 kW/phase. Nonresonant power conversion would be held by component limitations to a lower power level and lower operating frequencies with attendant high mass. Finally the reliable interruption of high-power dc currents in aerospace applications, by other than brute force methods, remains an unsolved problem.

APPENDIX - AVAILABLE COMPONENT TECHNOLOGY FOR HIGH-POWERED
ELECTRICAL SYSTEMS ON SPACECRAFT

David D. Renz

Table II lists some of the NASA Lewis programs that pertain to large-power (high voltage and high frequency) systems and components. This table shows that there does exist a large technology base in this area with many component development programs. Some of the components (D60T, D62T, D7ST, and the PTC 900 series diode) are now commercially available.

Figures 11 to 15 are examples of outputs obtained from an in-house transmission line analysis program. This program enables many variations in line parameters and materials to be compared. It is being used to estimate transmission line weights and losses and will be used as a design tool for a prototype transmission line. These figures are for a 1000-V, 100-A, 50-m-long system.

REFERENCES

1. Kennerud, L.L.: High Voltage Solar Array Experiments. NASA CR-121280 Mar. 1974.
2. Cole, R.W.; Ogawa, H.S.; and Sellen, J.M., Jr.: Operation of Solar Cell Arrays in Dilute Streaming Plasmas. (TRW-09357-6006-R000, TRW Systems; NASA Contract NAS3-10612.) NASA CR-72376, Mar. 1968.
3. Herron, B.G.; Bayless, J.R.; and Worden, J.D.: High Voltage Solar Array Technology. AIAA Paper 72-443, Apr. 1972.
4. Domitz, S.; and Grier, N.T.: The Interaction of Spacecraft High Voltage Power Systems with the Space Plasma Environment. Power Electronics Specialists Conference, Institute of Electrical and Electronics Engineers, 1974, pp. 62-69.
5. Stevens, N.J.: Solar Array Experiments on the SPHINX Satellite. NASA TM X-71458, 1973.
6. Stevens, N.J.; et al.: Investigation of High Voltage Spacecraft System Interactions with Plasma Environments. AIAA Paper 78-672, Arr. 1978.
7. McCoy, J.E.; and Konradi, A.: Sheath Effects Observed on a 10-Meter High Voltage Panel in Simulated Low Earth Orbit Plasmas. Spacecraft Charging Technology, 1978, NASA CP-2071, 1979, pp. 315-340.
8. Grier, N.T.: Experimental Results on Plasma Interactions with Large Surfaces at High Voltages. NASA TM-81423, Jan. 1980.
9. Ignaczak L.R.; et al.: The Plasma Interaction Experiment (PIX) Description and Test Program - Electrometers. NASA TM-78863, Apr. 1978.
10. Grier, N.T.; and Stevens, N.J.: Plasma Interaction Experiment (PIX) Flight Results. Spacecraft Charging Technology, 1978, NASA CP-2071, 1979, pp. 295-314.
11. Bowles, J.P.; Nakra, H.L.; and Turner, A.B.: A Small Series Tap on an HVDC line. IEEE Trans. Power Appar. Syst., vol. PAS-100, no. 2, Febr. 1981, pp. 857-861.
12. Elgerd, O.I: Electric Energy Systems Theory: An Introduction. McGraw-Hill, 1971.
13. Dewan, S.B.; and Straughen, A.: Power Semiconductor Circuits. John Wiley and Sons, 1975.
14. Weinberger, S.M.: Preliminary Design Development of a 100 kW Rotary Power Transfer Device. (GE-81SDS4215, General Electric Co.; NASA Contract NAS3-22266.) NASA CR-165431, 1981.
15. Mapham, N.: An SCR Inverter with Good Regulation and Sine-Wave Output. IEEE Trans. Ind. Gen Appl., vol. IGA-3, no. 2, Mar./Apr. 1967, pp. 176-187.

16. Robson, R.; and Hancock, D.: 10 kW Series Resonant Converter Design, Transistor Characterization, and Base-Drive Optimization. NASA CR-165546, 1981.

17. Schwarz, F.C.: Bi-Directional Four Quadrant (BD4Q) Power Converter Development. NASA CR-159660, 1979.

TABLE I. - CHARACTERISTICS OF A 50-m-LONG COAXIAL TRANSMISSION LINE

Direct-current resistance, ohm	0.0183
Alternating-current resistance, ohm	0.0194
Inductance, μ H	0.217
Capacitance, μ F	0.376
Characteristic impedance, ohm	0.760

ORIGINAL PAGE IS
OF POOR QUALITY

TABLE II. - NASA LEWIS PROGRAMS FOR LARGE SPACE ELECTRIC POWER SYSTEMS

Subject	Title	Specifications	Status
High-power transistor	Augmented Power Transistor, NAS3-22782	Voltage, 800 V at 100 A to 1000 V at 70 A at 70 A at transistor gain h_{fe} of 10; current, 400 A peak; switching frequency, 20 to 50 kHz	In development; prototype by January 1983
High-current probe	Fast-Recovery, High-Power Diode, NAS3-23280	Peak reverse voltage, 1200 V; average rated current, 150 A; surge current, 3000 A	In development; prototype by April 1983
PTC 900 series diode	Fast-Recovery Power Diode, NASA CR-165411	Peak reverse voltage, 1200 V; average rated current, 50 A; surge current, 3000 A; nanosecond recovery	Completed; commercially available
Thyristor	Fast-Switching, Gate-Assisted Turn-off Thyristor, NASA CR-134951	Voltage, 1000 V at 200 A; switching frequency, 10 to 20 kHz	Prototype completed
Solid-state dc switchgear	High-Voltage dc Switchgear Development for 1-kV dc Space Power Systems, NAS3-22646	Voltage, 1 kV; current, 25 A; power, 25 kW; i_{2t} trip	Prototype completed
25-kVA transformer	Design and Development of Multi-kilowatt Power Electronic Transformer, NAS3-21948	Voltage, 1500 V; frequency, 20 kHz; efficiency, 99.2 percent; weight, 7 lb	Prototype completed
75-kVAR capacitor	High-Frequency, High-Power Capacitor Development, NAS3-22668	Voltage, 600 V ac with 600 V dc bias; current, 120 A at 40 kHz; weight, 8 lb	Flight type completed
100-kW rotary transformer	Preliminary Design Development of 100-kW Rotary Power Transfer Device, NASA CR-165431	Input voltage, 440 V; output voltage, 1000 V at 4- to 25-kW modules	Preliminary design completed
D60T, D62T	Development and Fabrication of Improved Power Transistor Switches, NASA CR-159524	Voltage, 400 to 500 V; current, 50 A at $h_{fe} = 10$ and 200 A peak; switching frequency, 20 to 50 kHz	Completed; commercially available
D7ST	High-Current, Fast-Switching Transistor Development, NASA CR-165372	Voltage, 400 to 500 V; current, 100 to 150 A at $h_{fe} = 10$ and 400 A peak; switching frequency, 20 to 50 kHz	Completed, commercially available
High-voltage D7ST	High-Voltage Power Transistor Development, NASA CR-165547	Voltage, 1000 to 1200 V, current, 25 to 50 A at $h_{fe} = 10$ and 200 A peak; switching frequency, 20 to 50 kHz	Prototype completed
100-kW series-resonant converter	Characterization of Westinghouse D60T and D7ST and Power Transistor; and Design, Fabrication, and Test of Single-Stage, 10-kW Series-Resonant Converter, NAS3-22471	Input voltage, 230 V dc; output voltage, 200 to 500 V dc; current, 0 to 20 A; resonant frequency, 20 kHz	Prototype completed
25-kW series-resonant converter	Design, Fabrication, and Test of 25-kW Series-Resonant dc/dc Power Converter, NAS3-23159	Input voltage, 300 V dc; output voltage, 200 to 1000 V dc; output power, 25 kW; resonant frequency, 20 kHz	On going; in breadboard stage
Alternating-current power system	Resonant ac Power System Proof-of-Concept Test, NAS3-22777	Resonant frequency, 20 kHz; 1-kW modules; input voltage, 70 V dc	On going; in breadboard stage
Bidirectional power converter	Bidirectional Four-Quadrant (BD4Q) Power Converter Development, NASA CR-159660	Resonant frequency, 10 kHz; 3-kW level; bidirectional from 117 V ac (3 phase, 60 Hz) to 300 V dc and back	Prototype completed

ORIGINAL FACTORS
OF POOR QUALITY

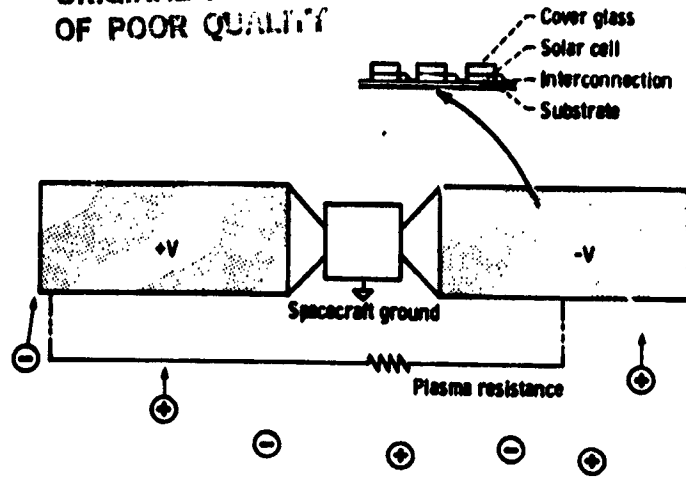

Figure 1. - Interactions between spacecraft high-voltage system and environment.

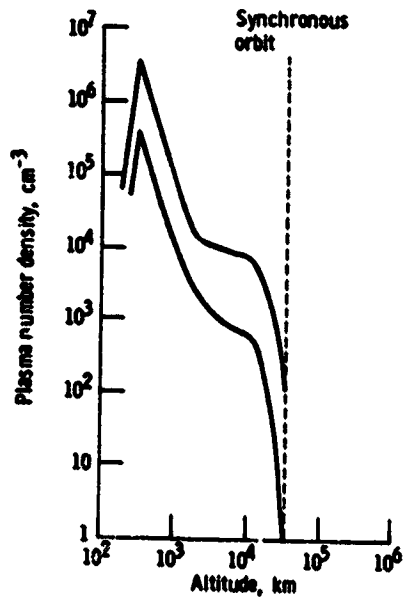

Figure 2. - Plasma number density as a function of altitude in equatorial orbit.

ORIGINAL QUALITY
OF POOR QUALITY

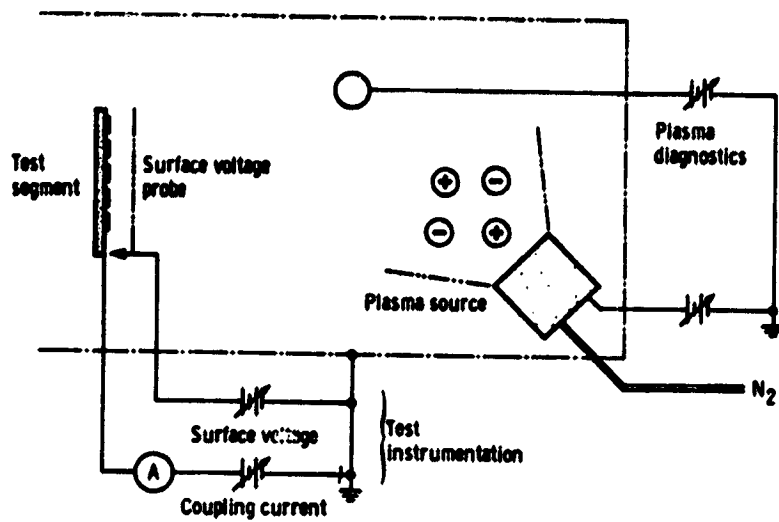

Figure 3. - Schematic diagram of test arrangement.

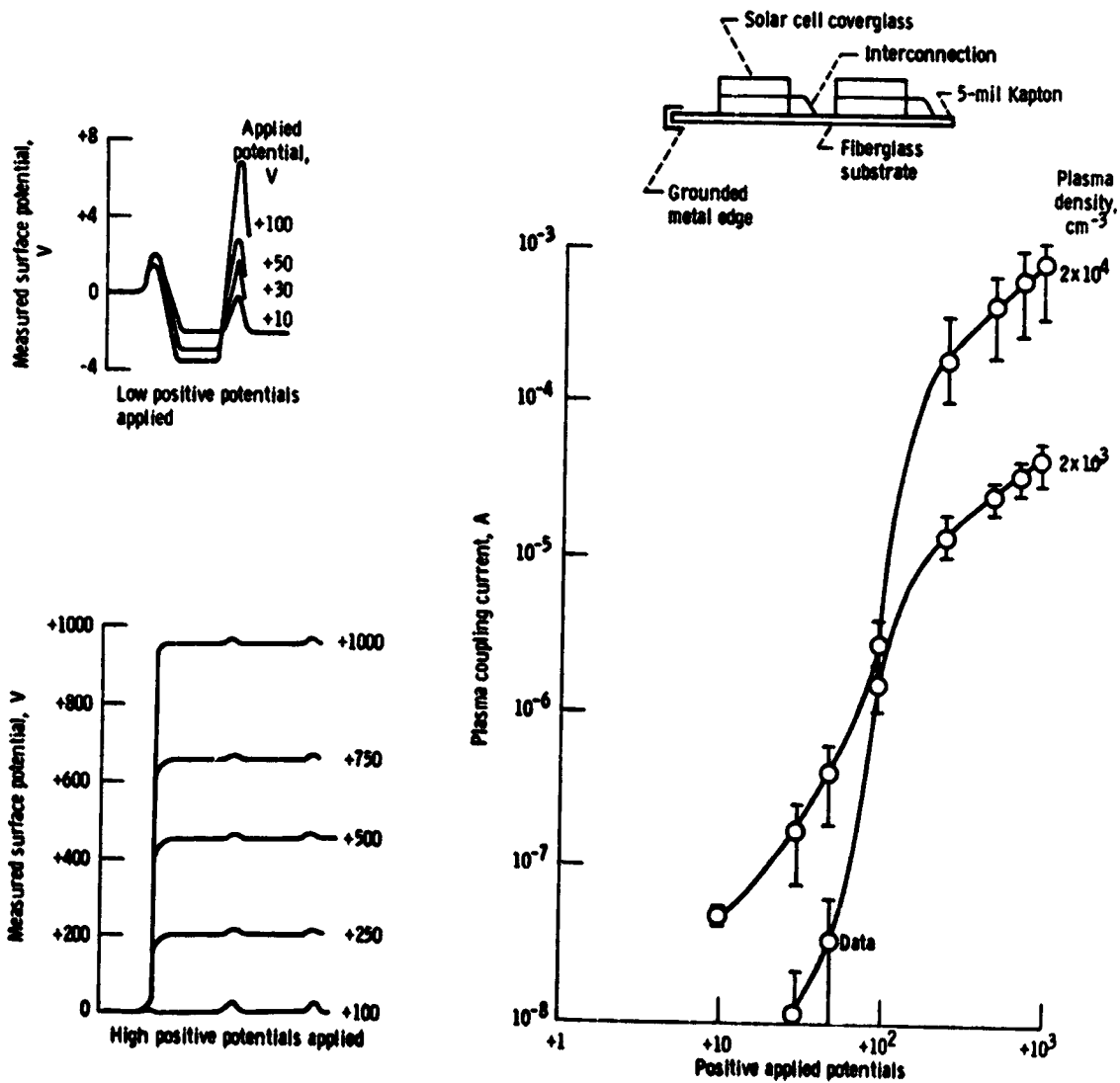

Figure 4. - Solar-array surface potential profiles and plasma coupling currents.

ORIGINAL PAGE IS
OF POOR QUALITY

S
Y

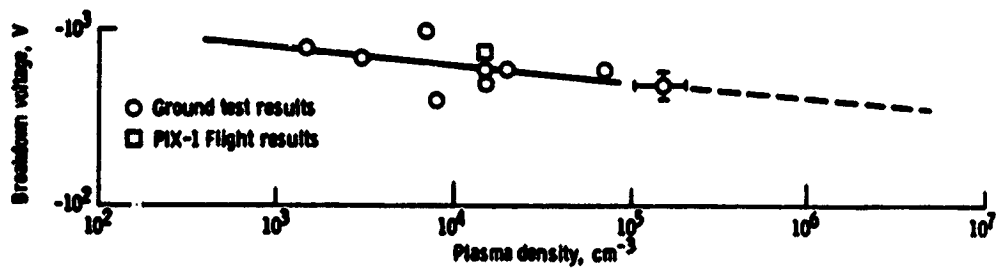

Figure 5. - Voltage threshold for discharges.

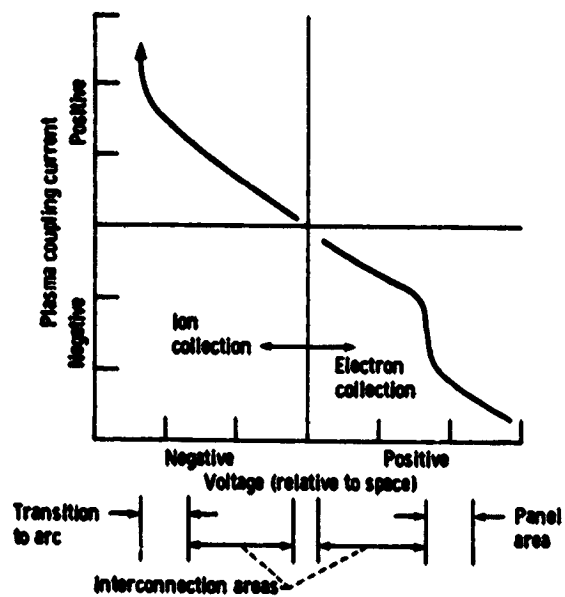

Figure 6. - Summary of interactions between solar array and environment.

ORIGINAL PAGE IS
OF POOR QUALITY.

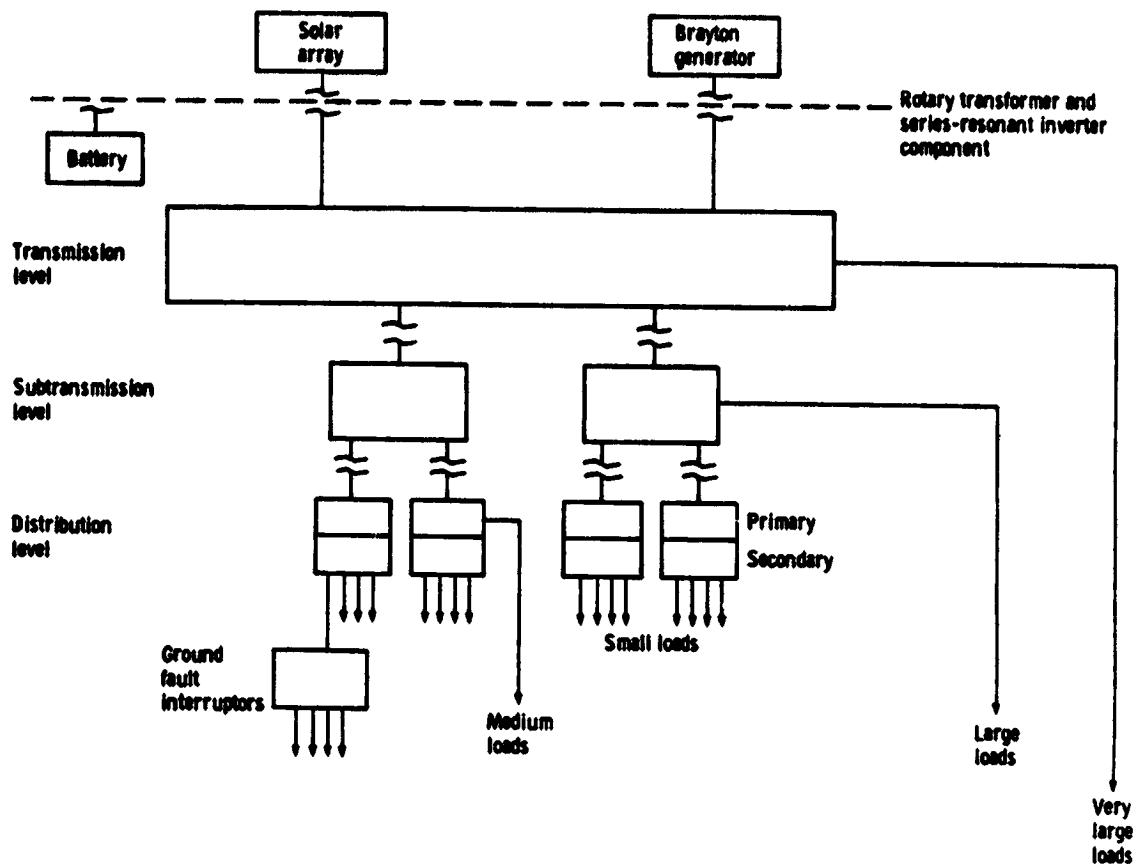

Figure 7. - Structure of alternating-current power system. (Typical primary spacecraft distribution equipment includes transformers, magnetic couplers, and frequency changers.)

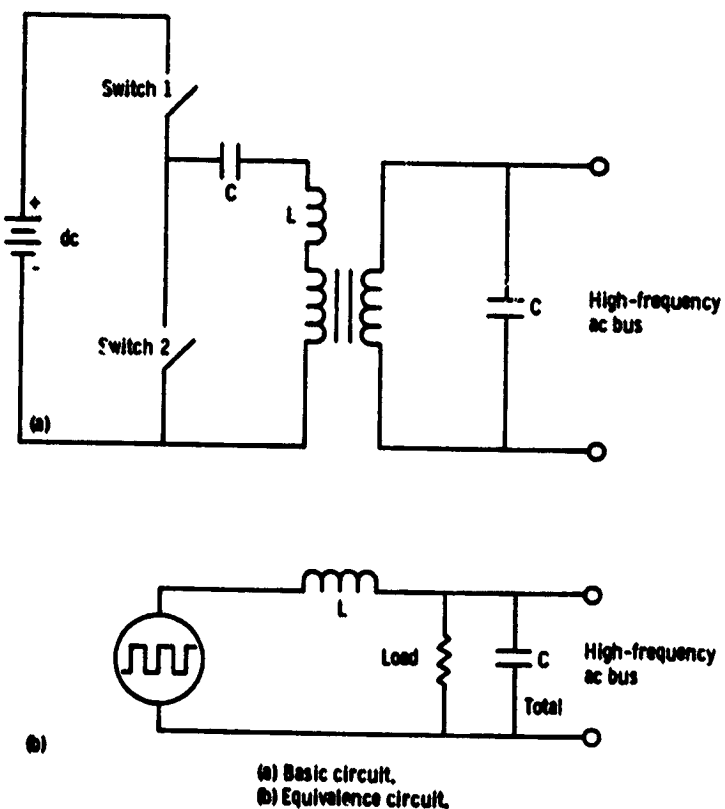

Figure 8. - Resonant half-bridge converter (dc-ac case). (Switching sequence determines direction of power flow.)

ORIGINAL PAGE IS
OF POOR QUALITY

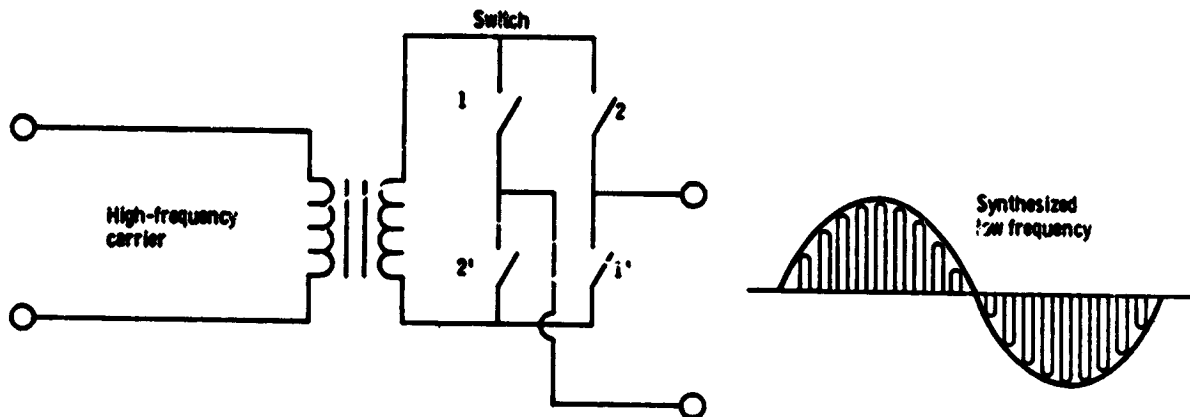

Figure 9. - Frequency waveforms synthesis. (Switching sequence determines direction of power flow.)

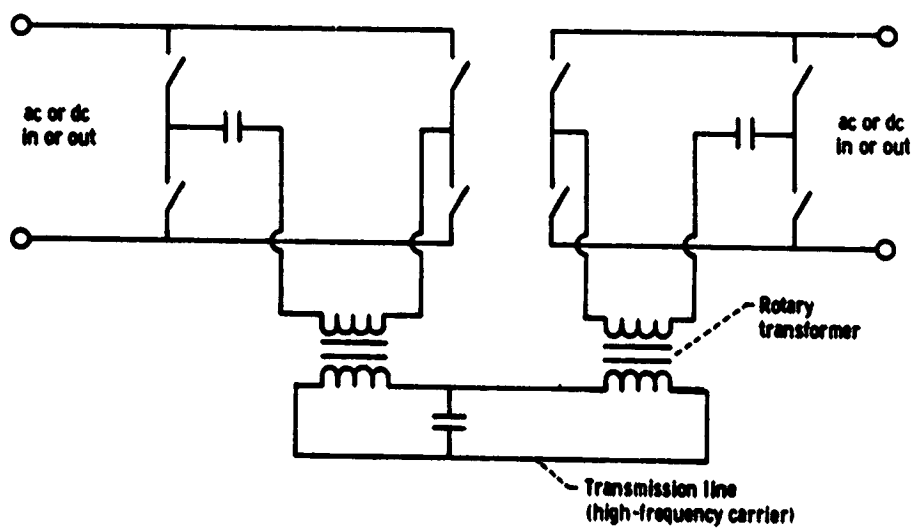

Figure 10. - Bidirectional "universal" power conversion.

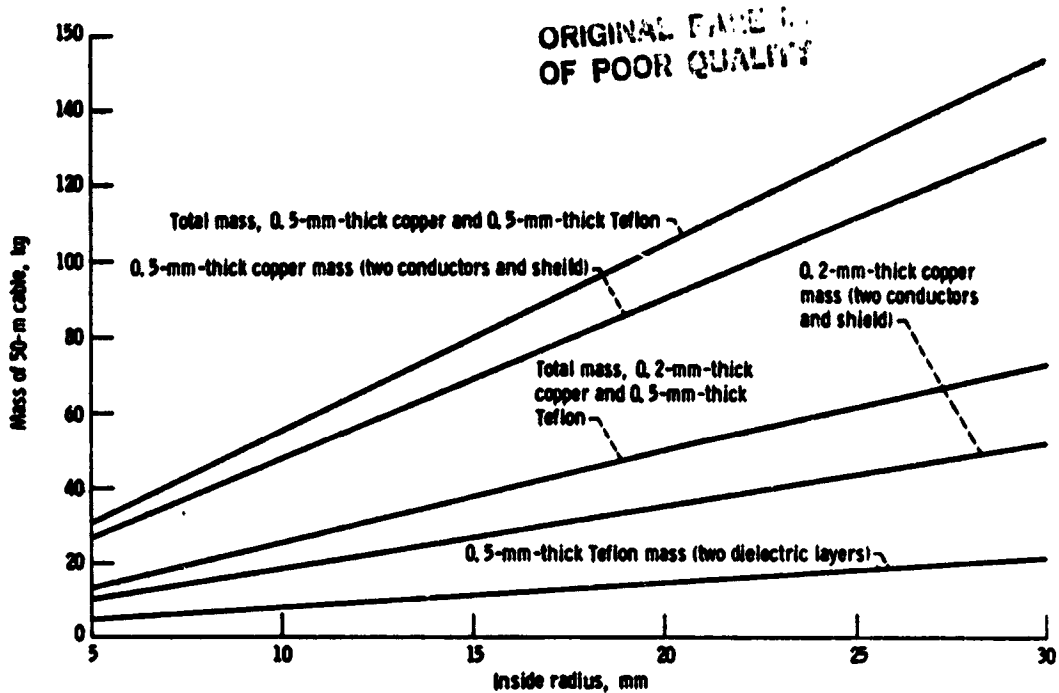

Figure 11. - Conductor and dielectric mass as a function of inside radius for 50-m-long coaxial cable. Voltage, 1000 V; current, 100 A.

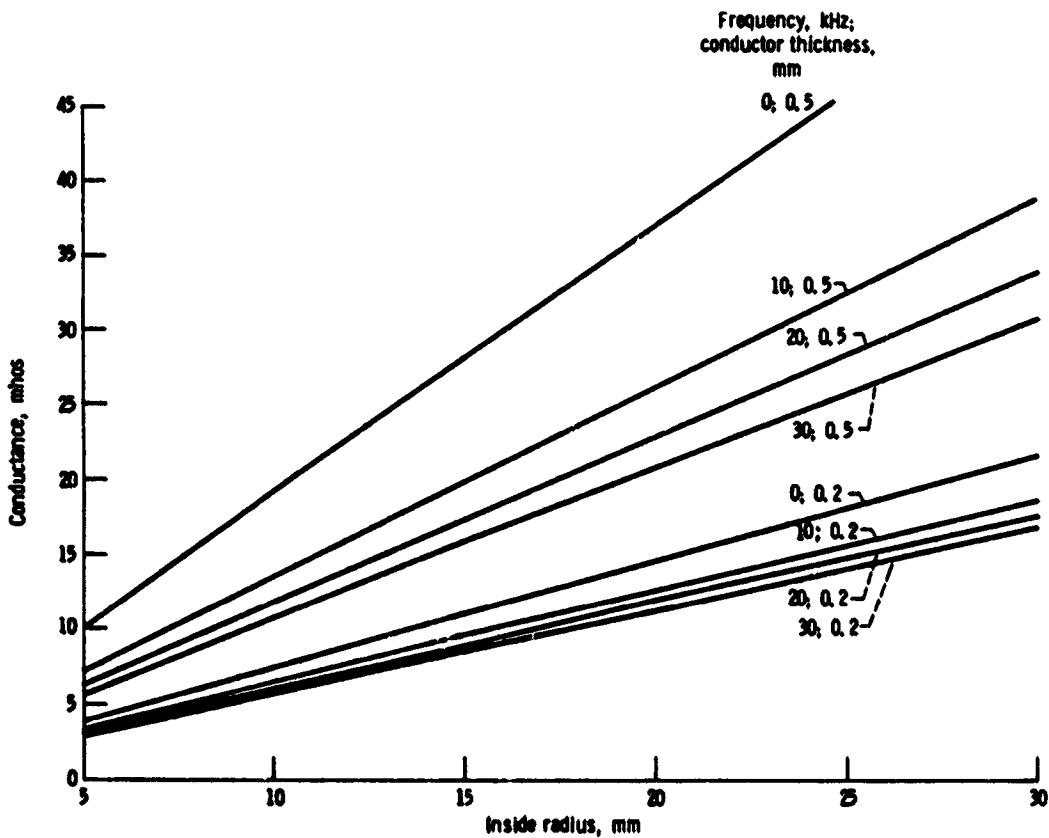

Figure 12. - Coaxial cable conductance as a function of inside radius for 50-m-long coaxial cable. Voltage, 1000 V; current, 100 A.

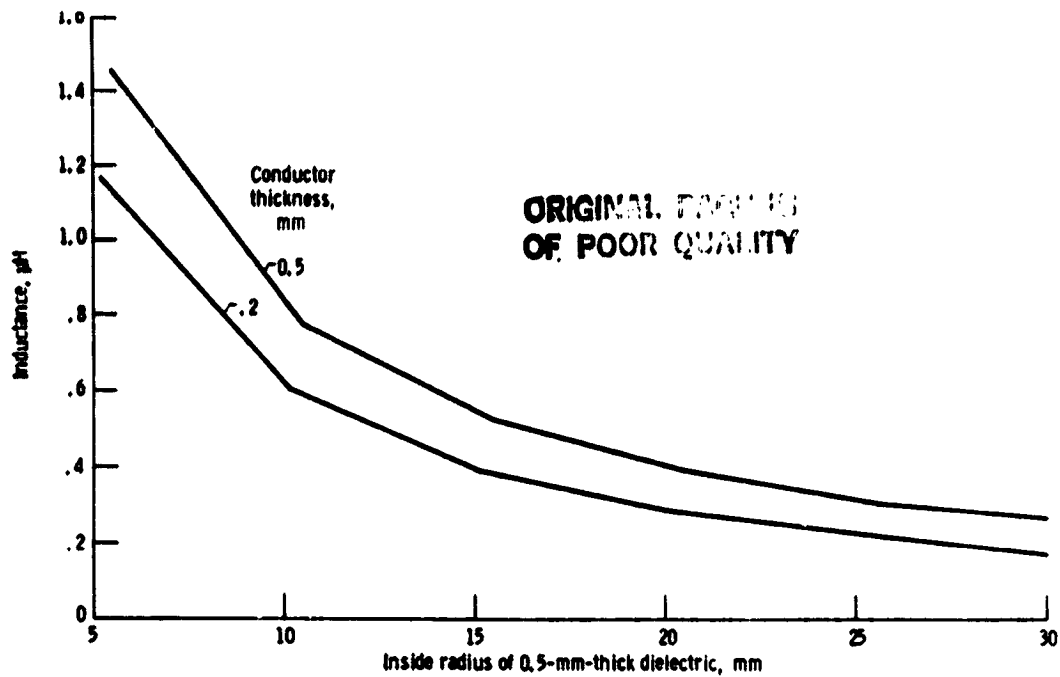

Figure 13. - Inductance as a function of inside radius for 50-m-long coaxial cable. Voltage, 1000 V; current, 100 A.

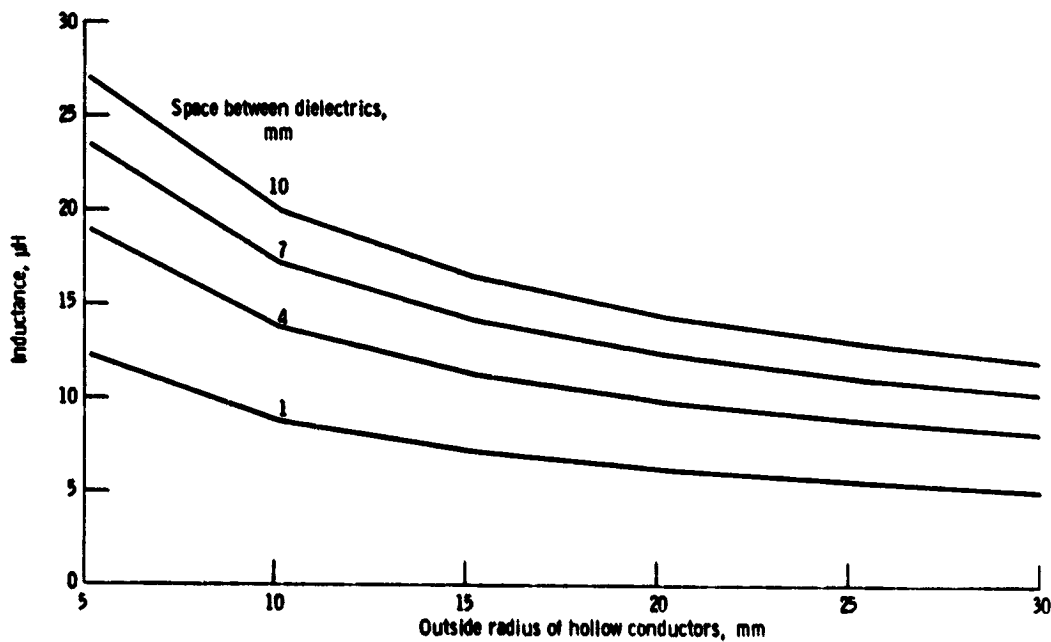

Figure 14. - Inductance of 50 m of unshielded parallel conductors as a function of conductor outside radius. Voltage, 1000 V; current, 100 A.

ORIGINAL FILED IN
OF POOR QUALITY

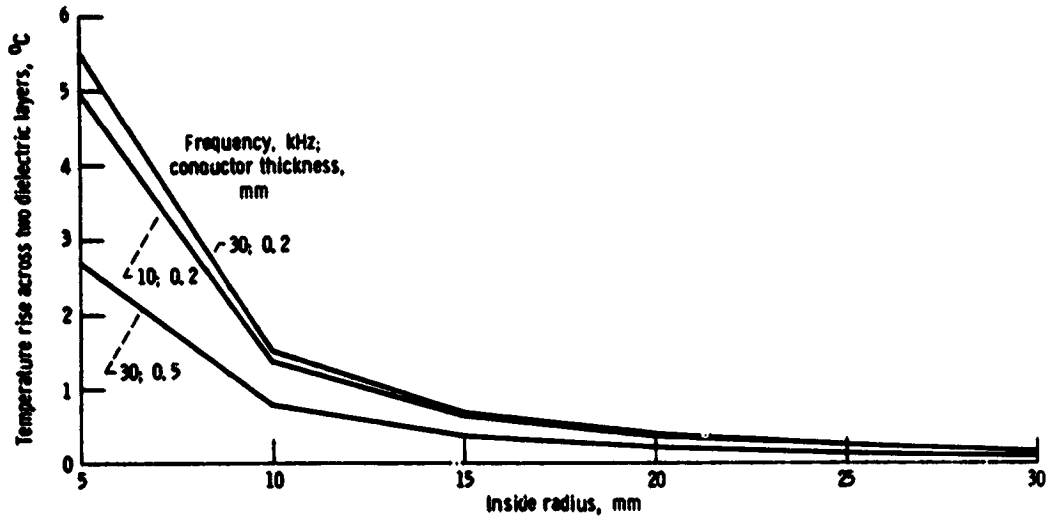

Figure 15. - Coaxial cable temperature rise across two 0.5-mm-thick dielectric layers as a function of inside radius. Voltage, 1000 V; current, 100 A.