

nasa CR-172,651

ENERGY

DOE/CS/54209-11  
(DE83011406)

NASA-CR-172651 ~~JPL-PUB-~~  
~~83-20~~  
1983 0018490

ELECTRIC VEHICLE CHASSIS DYNAMOMETER TEST METHODS  
AT JPL AND THEIR CORRELATION TO TRACK TESTS

By  
J. Marte  
J. Bryant

April 1983

Work Performed Under Contract No. AI01-78CS54209

Jet Propulsion Laboratory  
Pasadena, California

LIBRARY COPY

APR 26 1983

LANGLEY RESEARCH CENTER  
LIBRARY, NASA  
HAMPTON, VIRGINIA

NOIHTKAMH00



U. S. DEPARTMENT OF ENERGY



## DISCLAIMER

This report was prepared as an account of work sponsored by an agency of the United States Government. Neither the United States Government nor any agency thereof, nor any of their employees, makes any warranty, express or implied, or assumes any legal liability or responsibility for the accuracy, completeness, or usefulness of any information, apparatus, product, or process disclosed, or represents that its use would not infringe privately owned rights. Reference herein to any specific commercial product, process, or service by trade name, trademark, manufacturer, or otherwise does not necessarily constitute or imply its endorsement, recommendation, or favoring by the United States Government or any agency thereof. The views and opinions of authors expressed herein do not necessarily state or reflect those of the United States Government or any agency thereof.

This report has been reproduced directly from the best available copy.

Available from the National Technical Information Service, U. S. Department of Commerce, Springfield, Virginia 22161.

Price Printed Copy A05  
Microfiche A01

Codes are used for pricing all publications. The code is determined by the number of pages in the publication. Information pertaining to the pricing codes can be found in the current issues of the following publications, which are generally available in most libraries: *Energy Research Abstracts (ERA)*; *Government Reports Announcements and Index (GRA and I)*; *Scientific and Technical Abstract Reports (STAR)*; and publication NTIS-PR-360 available from NTIS at the above address.

5030-564

Electric & Hybrid Vehicle System  
Research & Development Project

DOE/CS/54209-11  
(JPL-PUB-83-20)  
(DE83011406)  
Distribution Category UC-96

# Electric Vehicle Chassis Dynamometer Test Methods at JPL and Their Correlation to Track Tests

J Marte  
J Bryant

April 1983

Prepared for  
U S Department of Energy  
Through an Agreement with  
National Aeronautics and Space Administration  
by  
Jet Propulsion Laboratory  
California Institute of Technology  
Pasadena, California

JPL Publication 83-20

n83-26761#

## ABSTRACT

Early in its electric vehicle (EV) test program, JPL recognized that EV test procedures were too vague and too loosely defined to permit much meaningful data to be obtained from the testing. Therefore, JPL adopted more stringent test procedures and chose the chassis dynamometer rather than the track as its principal test technique. Through the years, test procedures continued to evolve towards a methodology based on chassis dynamometers which would exhibit good correlation with track testing. Based on comparative dynamometer and track test results on the ETV-1 vehicle, the test methods discussed in this report demonstrate a means by which excellent track-to-dynamometer correlation can be obtained.

This document is available to the public through the National Technical Information Service, Springfield, Virginia 22161.

#### ACKNOWLEDGMENT

In preparing this report, frequent use was made of a report entitled "The DOE ETV-1 Electric Test Vehicle, Phase III Final Report, Performance Testing and System Evaluation" prepared by D.W. Kurtz (Reference 1). The authors hereby acknowledge Mr. Kurtz and the numerous personnel who contributed to his report. A special thanks is also due to R. Freeman and R. Livingston, both of whom worked long hours conducting a successful series of track tests.

## CONTENTS

I.	INTRODUCTION . . . . .	1-1
II.	TEST METHODOLOGY. . . . .	2-1
	A. VEHICLE ROAD LOAD DETERMINATION AND DYNAMOMETER ADJUSTMENTS . . . . .	2-1
	B. PROPULSION BATTERIES. . . . .	2-4
	C. DYNAMOMETER TESTING . . . . .	2-6
	D. INSTRUMENTATION . . . . .	2-8
	E. TRACK TESTING . . . . .	2-10
	F. DISCUSSION. . . . .	2-11
III.	ANALYSIS AND RESULTS. . . . .	3-1
	A. ENERGY CONSUMPTION. . . . .	3-1
	B. SAE J227a-D DRIVING CYCLE . . . . .	3-2
IV.	CONCLUDING REMARKS. . . . .	4-1
V.	RECOMMENDATIONS . . . . .	5-1
VI.	REFERENCES . . . . .	6-1

### APPENDIXES

A.	SAE J227a DRIVING CYCLE TESTING AT JPL . . . . .	A-1
B.	VEHICLE AND BATTERY CHARACTERISTICS FOR FTP URBAN DRIVING CYCLE AND STEADY SPEED TESTS AT 56, 72 and 89 km/h (35, 45 and 55 mi/h). . . . .	B-1

### Figures

2-1.	ETV-1 During Coastdown Testing at Edwards Air Force Base . . . . .	2-2
------	---	-----

2-2.	Comparison of On-Dynamometer Coastdown History with Idealized Coastdown History Based on Field Test Coefficients. . . . .	2-4
2-3.	Typical Charge Profile of ETV-1 Battery . . . . .	2-6
2-4.	ETV-1 Mounted on Clayton Twin-Roll Dynamometer in JPL Automotive Research Facility. . . . .	2-7
2-5.	Location of Current Shunts and Voltage Sense Points Required for Electrical Measurements. . . . .	2-10
2-6.	ETV-1 Under Test at the Transportation Research Center Test Track . . . . .	2-11
3-1.	ETV-1 Energy Consumption: Correlation of Dynamometer Test Results with Track Test Results. . . . .	3-1
3-2a.	ETV-1 Test Precision: "D" Cycle and 72 km/h (45 mi/h). . . . .	3-3
3-2b.	ETV-1 Test Precision: FTP Cycle, 56 km/h (35 mi/h), and 88 km/h (55 mi/h). . . . .	3-4
3-3.	SAE J227a-D Driving Cycle Battery Output Energy by Phases . . . . .	3-5
3-4.	JPL Interpretation of the SAE J227a-D Driving Cycle . . . . .	3-5
3-5a.	Motor Armature History from Dynamometer Test During SAE J227a-D Driving Cycle . . . . .	3-6
3-5b.	Motor Armature History from Track Test During SAE J227a-D Driving Cycle . . . . .	3-6
3-6.	Comparisons Between Track and Dynamometer Tests of Some Significant Test Parameters for the SAE J227a-D:	
3-6a.	Vehicle Speed . . . . .	3-10
3-6b.	Battery Current . . . . .	3-10
3-6c.	Battery Voltage . . . . .	3-11
3-6d.	Motor Armature Current. . . . .	3-11
3-6e.	Motor Armature Voltage . . . . .	3-12
3-6f.	Representative Battery Temperature. . . . .	3-12
3-6g.	Representative Motor Temperature. . . . .	3-13
3-7.	Typical Data Recording Format, Vehicle Velocity Versus Recording Period . . . . .	3-14

3-8. Battery Current Versus Time for Track and  
Dynamometer Tests . . . . . 3-15

Tables

2-1. ETV-1 Electrical Measurement . . . . . 2-9

3-1. Deviation from Track Values for Dynamometer-  
Measured Battery Output Energy (EBO) for Five  
Phases of the SAE J227a-D Driving Cycle . . . . . 3-7

3-2. Comparison of Tabulated Output. . . . . 3-8

3-3. Summary of Test Results Over Complete Tests . . . . . 3-9



## SECTION I

### INTRODUCTION

The Electric and Hybrid Vehicle Research, Development and Demonstration Act of 1976 established a governmental role in successfully bringing electric and hybrid vehicles (EHVs) into the commercial marketplace. The Energy Research and Development Administration (ERDA), as the original administrator, defined a phased activity which would become a major thrust of the U.S. Department of Energy (DOE) objective to reduce the Nation's dependence on foreign petroleum by developing the performance potential and economic viability of advanced electric vehicles that could be put into production in the 1980s.

The final phase of the activity involving the General Electric DOE Electric Test Vehicle (ETV-1) was the Phase III Test and Evaluation performed by the California Institute of Technology, Jet Propulsion Laboratory (JPL) conducted as an element of the DOE program. An initial report (Reference 1) was published which characterized and evaluated the performance of the DOE ETV-1 at a system level. It is the purpose of this report to continue this performance evaluation at a more detailed level and, in particular, define the degree of validity of the JPL dynamometer test technique in this type of electric vehicle testing.

After discussions with several of original equipment manufacturers (OEM), government agencies and other organizations concerned with the testing of motor vehicles, the JPL Electric and Hybrid Vehicle System R&D Project evolved a philosophy of vehicle testing which led to the adoption of the chassis dynamometer as the principal method for conducting engineering/development tests on EHVs. In addition, JPL strengthened existing EV test procedures to enhance the precision and meaningfulness of the test results.

Although the operational environment of the EHV is the physical environment of the road, it has often been demonstrated by JPL and many others that it is extremely difficult and therefore costly, to secure high-quality repeatable engineering data on a routine basis from road or track tests. The principal reasons being the variability of ambient temperature, pressure and wind as well as the variable grade and surface conditions of the test roadway or track. It is possible to correct for ambient temperature and pressure but the effects of the roadway and especially wind are much more difficult to handle. The most workable approach to these effects is to minimize them to the point that they can be neglected. However, winds of this low magnitude occur rather infrequently and this is a principal reason for the high cost of track testing.

The principal viable alternative to track tests for obtaining vehicle system-level engineering data is the chassis dynamometer. This method of testing has the advantage of completely eliminating wind and roadway slope effects. For this reason dynamometer testing is inherently cheaper (mainly because it is faster and more repeatable).

However, the clear advantages of dynamometer testing are only obtained at a cost. Aerodynamic resistance per se is completely absent and must be represented by a viscous loading device. Rolling resistance differs from the value for four wheels on the road surface since in the case of a Clayton dynamometer as used at JPL only two wheels are moving and the tire deflection (rolling loss) is caused by twin 8-in. diameter rollers which leads to higher tire temperatures. Before the absolute value of data obtained by dynamometer testing can be deemed credible, it is necessary to include suitable adjustments in the dynamometer setup and to show that these adjustments produce data which closely matches track test values over an appropriate range of test parameters and driving cycles. Experience has shown that the data required for the dynamometer setup adjustments can be obtained by a limited amount of careful coastdown testing. However, the final proof of credibility of the dynamometer test technique as applied at JPL can only come from a comparison of the dynamometer data with reliable track data. Toward this end, a limited series of comparable tests were conducted at the test track of the Transportation Research Center of Ohio in East Liberty, Ohio and on the Clayton twin-roll dynamometer at the JPL Automotive Research Facility. Road-load data for the dynamometer load settings were obtained from coastdown tests performed on the 7,000-ft South Runway at Edwards Air Force Base near Lancaster, California. The test car used to evaluate the track-to-dynamometer correlation was the DOE ETV-1 electric vehicle developed by the General Electric Company and the Chrysler Corporation for DOE.<sup>1</sup>

The batteries used in these tests were the Globe-Union EV-1000 model which was based on the earlier Globe EV2-13 developed as part of the ETV-1 contract. Two versions of the EV-1000 were used. In the earlier dynamometer tests a pre-production version (designated EV-1000(A) by JPL) was used and in later tests, including all track tests, the production version (designated EV-1000(B) by JPL) were utilized. The fact that different sets of batteries were used for the two tests does account for part of the difference in range. However, the most significant parameter in the comparisons is vehicle energy economy. No significant differences in energy economy performance between the two versions were noted.

A summarized evaluation of the track and dynamometer results is presented in Reference 1. Since then, detailed track data has become available for analysis. This report will consider these more detailed comparisons, particularly within the various phases of the SAE 227a-D driving cycle tests (Reference 2).

In both the track and the dynamometer testing, careful procedures have been utilized to assure comparable test conditions to the extent possible. However, no attempt was made to reproduce actual in-use driving patterns beyond the utilization of various standard driving cycles or to simulate the variations in performance which result from the varying habits of different drivers.

---

<sup>1</sup>JPL managed this contract as part of its Vehicle Systems R&D Project for DOE.

## SECTION II

### TEST METHODOLOGY

Electric vehicle testing at JPL is based on the SAE J227a Electric Vehicle Test Procedure. However, JPL has developed some test methods which differ, either slightly or significantly, from the methodology described in the SAE procedure. The deviations are described in this section of the report. For a more detailed discussion see Appendix A.

As discussed in Section I, except for determination of road loads and the comparative track testing considered herein, testing at JPL is carried out on a Clayton chassis dynamometer of the type used by the Environmental Protection Agency (EPA) for vehicle exhaust emission certification testing. There were four major reasons for selecting the dynamometer as the principal test device.

- (1) Much of the test work at JPL consists of in-vehicle battery performance comparisons. In order to minimize the test-to-test variability JPL chose to use the controlled conditions within a dynamometer facility in preference to track testing.
- (2) Characterization of batteries and other drive-train components during in-vehicle testing was necessary to determine potential system-level interface problems in the developmental components.
- (3) A large computerized data handling system was available at the JPL Automotive Research Facility.
- (4) Dynamometer testing is less expensive when the main objectives are to perform component comparisons and obtain engineering data.

#### A. VEHICLE ROAD LOAD DETERMINATION AND DYNAMOMETER ADJUSTMENTS<sup>2</sup>

Before a vehicle can be properly tested on a chassis dynamometer, it is necessary to characterize the dissipative losses associated with on-road travel such as the aerodynamic drag and rolling resistance losses. This road load is essential in order to assess range and make comparisons to the values projected by the developers of the vehicle. There are several ways in which these can be determined but coastdown testing is probably the most common and direct method. Because of its apparent simplicity, the procedure is widely used; however, results are often inaccurate. Properly conducted coastdown tests<sup>3</sup> are, in reality, very difficult to perform. Figure 2-1 shows the ETV-1 during coastdown testing.

---

<sup>2</sup>Additional discussion of this topic is available in Reference 1.

<sup>3</sup>Coastdown testing was performed on a limited-use concrete runway at the Edwards Air Force Base near Lancaster, California. Velocity versus time data were collected by a Nucleus NC-7 Precision Speedometer (5th wheel) and recorded with on-board HP 7100 B Strip Chart Recorder.



Figure 2-1. ETV-1 During Coastdown Testing at Edwards Air Force Base

The key to successful coastdown testing is to carefully measure and monitor as many variables as possible and to minimize all that cannot be measured or controlled. For instance, wind speed and direction were continually recorded and no testing was performed unless the speeds were less than 3 km/h during the test period. This is the maximum allowable wind speed where yaw angle effects on drag can be ignored (previously determined by JPL, Reference 3). The tire temperatures were recorded after every second run. To minimize other uncertainties, the half axles and disc-brakes were removed, so that the remaining rolling losses resulted only from the tires and wheel bearings. This necessitated that the vehicle be towed up to approximately 100 km/h (60 mi/h) and released to coast over a carefully surveyed segment of track. This segment was 0.9 km (3,000 ft) long and had a constant grade of 0.177%. Each run was then analyzed independently using the grade, wind, tire temperature and air density data associated with the run.

The objective behind accurate road load determination is to be able to cause the dynamometer system to absorb the same aerodynamic and rolling power as would be dissipated on the road under the same set of standard conditions (i.e., some specified ambient temperature and pressure, zero wind and zero grade). Unfortunately, the standard test condition principle is often ignored in test programs. In that event, even carefully conducted coastdown tests would yield quite different results from day to day (and especially from season to season) by virtue of the variable air densities and tire temperatures. Specifying standard conditions requires that the vehicles' aerodynamic

drag and rolling resistance coefficients<sup>4</sup> be determined from the coastdown tests. The data reduction procedure by which these coefficients were determined is based on the work of White and Korst (Reference 4) which was later extended and refined at JPL by Dayman (Reference 5). With the vehicle coefficients determined, an ideal coastdown history under standardized test conditions was mathematically developed. Here the JPL procedure goes a step beyond the normal EPA method which establishes a single dynamometer adjustment for aerodynamic and rolling resistance losses at a single speed set point. In the JPL procedure, where the rolling and aerodynamic losses are separately matched on the dynamometer, much of the road load error at speeds other than the 50 mi/h set point of the EPA procedure is eliminated. Two incremental coast periods (90 to 73 km/h and 32 to 16 km/h) were identified as points to be matched on JPL's Clayton twin-roll dynamometer. This use of a high-speed and a low-speed calibration point allows the aerodynamic losses to be separated from the rolling and mechanical losses. This particular dynamometer has been retrofitted to provide an external motoring capability. The vehicle, with half-shafts and disc brakes still removed, was first warmed up on the dynamometer by motoring at 80 km/h for 5 min and 57 km/h for 15 min. After an estimate for aerodynamic power was set into the dynamometer power absorption unit (PAU), the vehicle was motored to about 90 km/h and the coastdown time from 32 km/h to 16 km/h was noted. Two variables, tire pressure and normal force,<sup>5</sup> were iteratively adjusted until the on-dynamometer coastdown time matched the predetermined ideal coastdown time.

After achieving a match at the low velocity condition, coastdowns were conducted from 90 km/h to 73 km/h. Water level was adjusted in the PAU until a match with the ideal time was reached. Some iteration was required between the high- and low-speed ranges until the best trade-off was reached. The dynamometer was then motored up to approximately 100 km/h (65 mi/h) and the vehicle-dynamometer system was allowed to coast to below 16 km/h (10 mi/h). Figure 2-2 shows a comparison of the coastdown history of the vehicle-dynamometer system with the ideal or standardized history. As a further check on the operation, the vehicle-dynamometer coastdown history was independently analyzed using the same numerical technique employed for the track coastdowns. The road-load power resulting from dynamometer inertia weights, bearing drag and vehicle tires was within 2% of the ideal over the whole speed range of interest. Following the dynamometer coastdown, the half axles and disc-brake assemblies were re-installed and the vehicle was ready for dynamometer testing.

---

<sup>4</sup>For example, aerodynamic drag is defined, using the drag coefficient, as  $D = 1/2 \rho V^2 C_D$  where  $\rho$  is atmospheric density and thus a function of both the temperature and the pressure of the atmosphere. Therefore, knowing the coefficient allows the drag to be computed for standard atmospheric conditions.

<sup>5</sup>Normal force, or weight on the driving wheels, was altered by applying constant pressure to a pneumatic lift placed under the front of the vehicle.

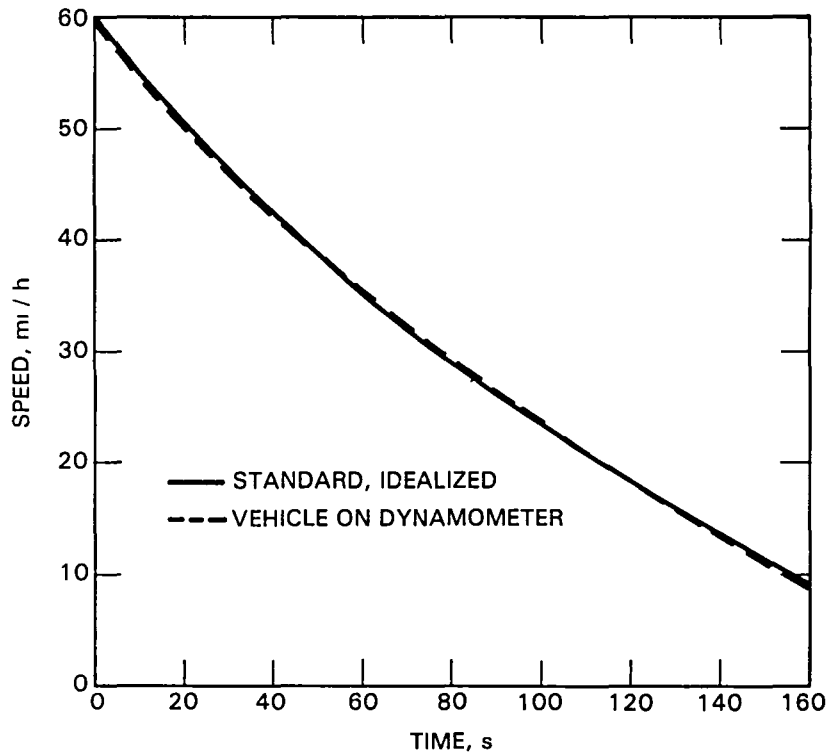

Figure 2-2. Comparison of On-Dynamometer Coastdown History with Idealized Coastdown History Based on Field Test Coefficients

## B. PROPULSION BATTERIES

The propulsion battery performance is the single largest variable in electric vehicle testing. The available capacity of a lead-acid battery does not remain constant over its lifetime and it is extremely sensitive to such things as charge procedures and temperature. Because of this, JPL has paid special attention to the propulsion batteries. The ETV-1, as well as all other vehicles tested at JPL, has either had new batteries or batteries which were not yet on the declining portion of the capacity-age curve. These batteries, when new, were conditioned by conducting 10 to 15 charge-discharge cycles. During the conditioning process, weak batteries were identified (and replaced) and the battery-charging procedure was refined. Identical battery preparation procedures were followed for both test techniques.

Conditioning was done by discharging the propulsion batteries into a resistive load. The batteries were also discharged during checkout of the instrumentation and driver familiarization with the vehicle. Both types of discharge form the conditioning process and both are important. It has been JPL's experience, although limited, that resistive load discharges do not necessarily complete the conditioning process. Different rates of discharge or different types of discharge (e.g., pulsed currents) need to be incorporated into battery conditioning.

Battery charging can be a major source of variability. The charging method not only affects the subsequent discharge capacity but also battery life, heating and recharge efficiency. To ensure that batteries were completely recharged prior to each test, a "quasi-equalization" charge was used. In place of the on-board charger, a commercially available power supply was used. This device was equipped with external controls tailored to battery charging. The charge algorithm used was as follows:

- (1) Charge at a constant 25 A until a pre-set battery pack (clamping) voltage is achieved.
- (2) Once the clamping voltage is reached, continue charging for 6 h while maintaining the pack voltage at the clamping value. This allows the current to taper to a lower current (nominally 4 A).
- (3) The clamping voltage is automatically adjusted throughout the charge to account for the varying battery electrolyte temperature (temperature compensation:  $7.2 \text{ mV}/^{\circ}\text{C}/\text{cell}$ ).

The clamping voltage for the battery was empirically determined during the battery conditioning process. Initial charging during conditioning was done with conservatively low clamping voltages. After each subsequent discharge/charge cycle, the voltage was increased 0.1 V per module until the battery current, after 5 h of the timed portion of the charge, was between 4 and 5 A. Figure 2-3 shows a typical charge profile. The point at which the temperature-compensated clamping voltage is reached very closely corresponds to where, on a coulombic basis, 95% of the previous discharge has been returned to the batteries. It can be seen that at this same point the battery pack has entered a less efficient charge regime as indicated by the increased battery heating rate despite rapidly decaying current. The timed portion of the charge was 6 h and resulted in a fixed overcharge in terms of ampere-hours (Ah). Because of the constant coulombic overcharge, the percentage of overcharge varied depending on the previous depth of discharge (DoD). Typically, overcharge varied from 15 to 20% on an Ah basis for this "quasi-equalization" charge; charge efficiency was subordinated in favor of battery capacity repeatability. If the battery pack is in good condition, the single largest variable related to battery capacity is battery electrolyte temperature. Within the constraints of the existing SAE J227a test procedures, allowing for thermal mass considerations, it is conceivable that tests may be conducted with initial battery temperatures ranging anywhere from  $16^{\circ}$  to  $42^{\circ}\text{C}$ . Battery capacity and the resulting vehicle range, can easily vary by 25% due solely to this parameter.

Rather than accepting the variability induced by different battery temperatures, tests were conducted with an initial electrolyte temperature of  $21^{\circ} \pm 3^{\circ}\text{C}$ . This temperature was chosen arbitrarily as a value which was convenient to maintain and not inconsistent with the EPA test procedures in order to standardize test results for comparative purposes. It should be recognized that in actual everyday use, the electrolyte temperature at the initiation of the charge cycle may vary quite widely from this value. In particular, the reader should understand that the vehicle ranges reported herein will only be realized at the temperature used in the tests and that in real-world use could vary considerably in either direction. To satisfy the

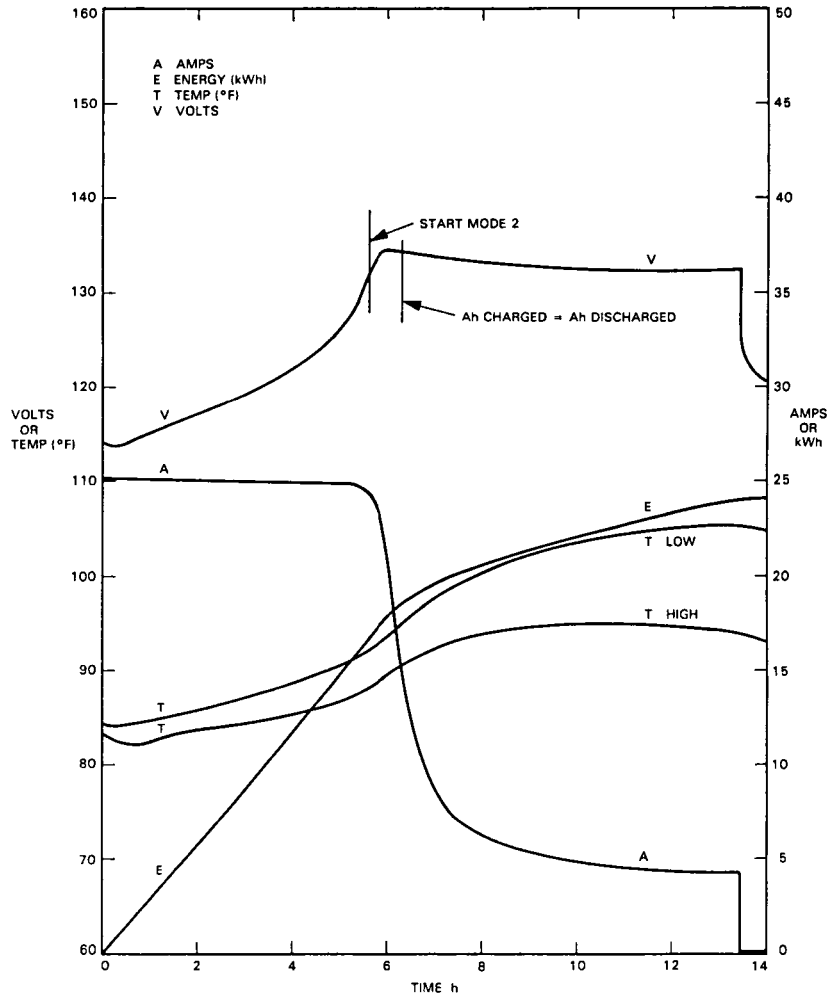

Figure 2-3. Typical Charge Profile of ETV-1 Battery

21°C criterion, ETV-1 testing could only be conducted every other day because of the large thermal mass of the battery.<sup>6</sup> In the interim, the entire vehicle was "soaked" at 21°C. In a user environment a controlled soak period would not be present and it is possible that the vehicle range would benefit from warm batteries just coming off the charge cycle.

### C. DYNAMOMETER TESTING

All performance tests on the dynamometer (Figure 2-4) are preceded by a dynamometer warm-up and verification of such test parameters as tire pressure, lift pressure, dynamometer inertia weight and PAU adjustment, and other<sup>6</sup> controlled variables of this nature. The dynamometer is warmed up and set according to the procedures specified by the EPA in their certification testing of IC-engine vehicles. Having satisfied the pre-test conditions, the cold vehicle is positioned on the dynamometer and testing is initiated. For constant-speed

<sup>6</sup>During track testing, the unavailability of an air-conditioned "soak room" required the use of ducted chilled air to the battery compartment. This also allowed testing to be performed every day.





Figure 2-4. ETV-1 Mounted on Clayton Twin-Roll Dynamometer in JPL Automotive Research Facility

tests the vehicle is accelerated as rapidly as possible to the test speed which is then held constant until test termination. During driving-cycle tests (SAE J227a and FTP) the same pre-test requirements exist. However, the SAE driving schedules have been refined to a specified time versus-velocity profile.<sup>7</sup>

These specified driving cycles have been used internal to JPL to minimize the subjectivity of drivers in the interpretation of these cycles. The main objective in completely defining the J227a driving cycle was to minimize test-to-test variability and vehicle-to-vehicle variability due to the vagueness of the procedures. Additional information which defines the specifics of these standardized driving profiles and some of the rationale used in establishing them is provided in Appendix A.

---

<sup>7</sup>The SAE J227a driving cycles are defined only at certain transition points. JPL has interpreted and standardized the cycle during the phases where velocity varies to be consistent with acceleration and deceleration rates observed in EPA Federal Test Procedure cycles (Reference 6).

Range tests are terminated by any one of several criteria:

- (1) Inability to maintain rates of acceleration sufficient to reach the cruise speed of the SAE cyclic profiles within 2 s of the specified time.
- (2) Failure to maintain some minimum battery voltage. For lead-acid batteries JPL has standardized on two voltage criteria:
  - (a) 1.3 V per cell during acceleration or
  - (b) 1.65 V per cell under any other condition.<sup>8</sup>
- (3) Inability to maintain prescribed speed within +5%.
- (4) Miscellaneous conditions which might prove to be deleterious to the vehicle or its battery system; such as excessive motor or controller temperature.

Because of the variety of test termination criteria, many of the cyclic tests, especially the D-cycle, terminate prior to complete utilization of the battery's capacity compared to tests which were less demanding in terms of power requirements.

Some testing at JPL has also been done using the EPA Urban Driving Cycle. These tests are not subject to the acceleration-to-speed termination criteria. However, most vehicles tested to date have failed due to low battery voltage during the high acceleration rate when approaching the 55 mi/h (89 km/h) segment near the beginning of the cycle. Testing to EPA procedures has been very limited at JPL and has been done primarily to allow an investigation into the possibility of using this cycle as a basis for future EV testing. As presently driven, the 7.5-mi (12 km) procedure is followed by a 10-min soak as required in the case of emissions tests. After the soak, a complete 7.5 mi (12 km) procedure is driven followed by another 10-min soak. This process is repeated until the vehicle fails one of the termination criteria which is generally low battery voltage.

#### D. INSTRUMENTATION

The primary measurement requirements were for a description of electrical power flow and overall vehicle performance (i.e., energy consumption and range). The electrical measurements shown in Table 2-1 are used to define the electrical power flow and the efficiencies of the major electrical power elements. Because of the chopper controllers in today's electric vehicles, special instrumentation is required. The wattmeters used in this testing were specifically designed and developed by JPL for this purpose. The power (V x A) is determined in real-time with a frequency response of 50 kHz to attain a frequency response accuracy of 1% for the 2-kHz chopper in ETV-1. During testing, the observed (long-term) dc accuracy of the wattmeters has been within 2% of reading in the range of 20 to 100% of full scale.

---

<sup>8</sup>Recently increased to 1.75 V.

Table 2-1. ETV-1 Electrical Measurement

Basic Measurements <sup>a</sup>		On-Board Power Measurement Instrument (PMI)	
Parameter	Range	Parameter	Range, kW
Battery and armature voltage	0-200 V	Battery out and in <sup>b</sup>	0-100
Battery and armature current	<u>±</u> 500 A	Armature in and out <sup>b</sup>	0-100
Field voltage	0-200 V	Field power	0-5
Accessory battery voltage	0-25 V	Recharge power	0-10
Accessory battery current	0-50 A		
Recharge voltage	0-200 A		
Recharge current	0-50 A		

<sup>a</sup>Transducers connected to vehicle's electric power system.  
<sup>b</sup>Regenerative power during braking.

Figure 2-5 shows the location of the current shunts and voltage sense points needed for the power measurements. These voltage and current signals were supplied to the wideband wattmeters and provided the key parameters in the characterization of power flow. The wattmeter design was based on the unique requirements of a battery-powered vehicle using armature chopping control.

Power, voltage, and current signals are isolated from the vehicle's battery potential through isolation circuits internal to the wattmeter and then directed to a digital data acquisition system. The data are all recorded on magnetic tape. Recording is done at various intervals depending on the nature of the test. For instance, during Schedule "D" tests, recording intervals can be as small as 0.1 s to allow characterization under dynamic conditions. Reduction of the data recorded on magnetic tape is accomplished on a general purpose computer on an overnight basis. Reference 7 contains the details of the complete data acquisition system from sensors through data processing.

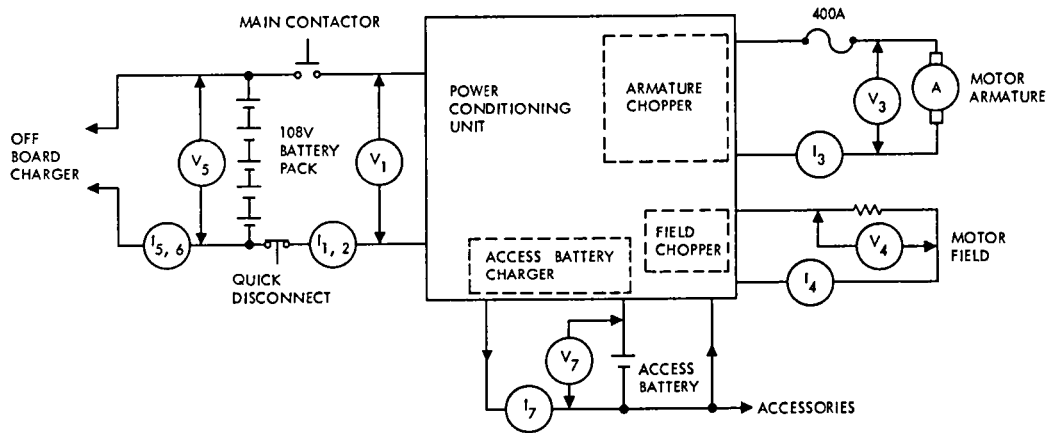

Figure 2-5. Location of Current Shunts and Voltage Sense Points Required for Electrical Measurements

#### E. TRACK TESTING

The primary objective of the Track Test Program was to establish a correlation between the major dynamometer test program and actual moving-vehicle, on-road tests. A secondary objective was to obtain quantitative measurements of vehicle performance characteristics (acceleration, braking, dynamic handling) for comparison to other electric and conventionally powered vehicles.

The track test program was conducted at the Transportation Research Center (TRC) located in East Liberty, Ohio, during June and July, 1981 (Figure 2-6). In order to satisfy the primary objective, the vehicle-related parameters existent during the dynamometer tests were duplicated for the track test program wherever possible. Because of the complete on-board instrumentation and supporting equipment,<sup>9</sup> the vehicle test weight was approximately 1%

<sup>9</sup>This equipment consisted of the on-board Power Measurement Instrument (PMI) which was developed and fabricated by JPL; an On-Board Measurement System (OBMS) Compudas Instruments, manufactured by the Ithaco Corporation, which uses a microcomputer to control and record a continuous data stream; a strip-chart recorder containing pre-recorded driving-cycle profiles and two accessory batteries to power these systems.

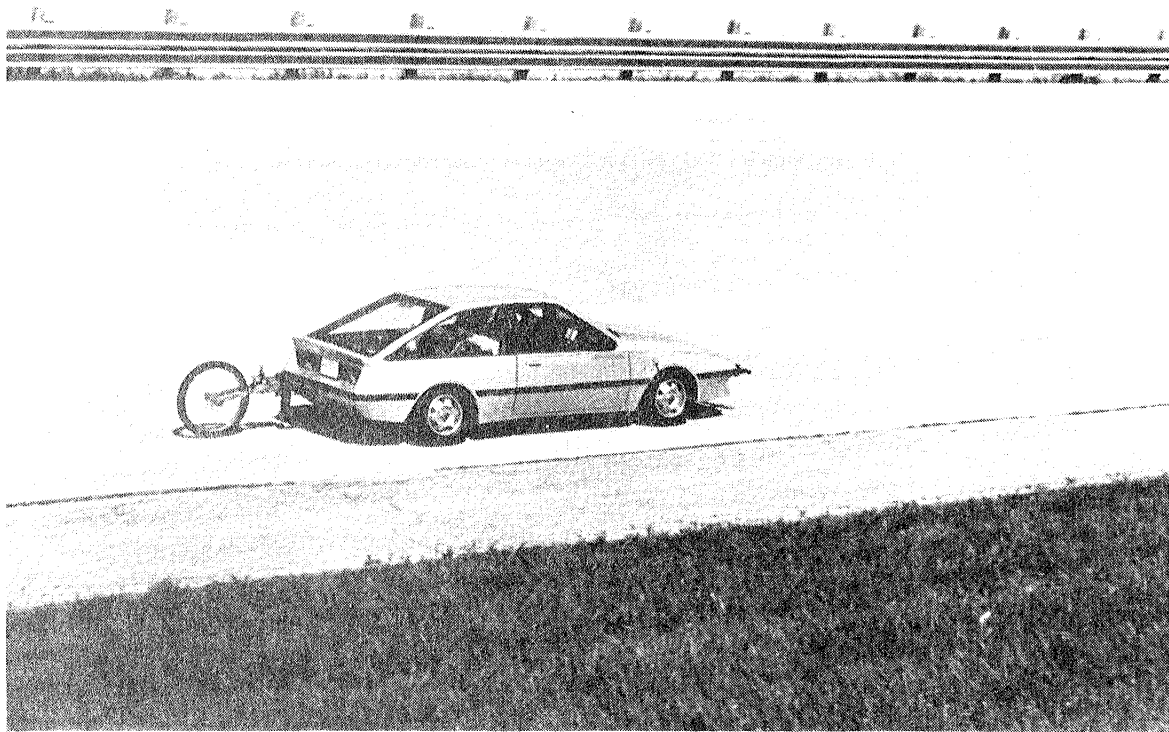

Figure 2-6. ETV-1 Under Test at the Transportation Research Center Test Track

greater than on the dynamometer. The front/rear weight distribution was 50/50. As specified by the JPL standardized test conditions, the entire vehicle temperature and battery electrolyte temperature were stabilized at 70°F (21°C) +5°F (3°C) prior to all range tests. Ambient temperatures during track testing ranged from 64°F (18°C) to 81°F (27°C), and winds averaged about 4 to 5 mi/h (6-8 km/h).

#### F. DISCUSSION

Much of the above discussion on standardization of EV test procedures at JPL was based on the requirements of lead-acid batteries. The main objective was to minimize the variability from test-to-test and from vehicle-to-vehicle thereby allowing comparisons of various batteries on a standardized basis. However, for the purpose of comparing results between track and dynamometer tests the significant parameter is the vehicle energy requirement (i.e., battery output energy per unit distance traveled).

### SECTION III

### ANALYSIS AND RESULTS

#### A. ENERGY CONSUMPTION

The measured energy (leaving the battery terminals) required to drive the ETV-1 at constant speeds, over the SAE J227a-D and EPA Urban (FTP) driving cycles on the dynamometer and in supporting track tests is presented in Figure 3-1. Energy required is normalized by distance traveled in order to compare the energy consumption of the total vehicle under various driving conditions. The track and dynamometer results all compare with a maximum variance of about 5%. Uncontrolled ambient conditions and the slight instrumentation weight penalty prevented the track tests from exactly duplicating the standardized conditions adopted for dynamometer tests. From computer simulation, the 1% weight penalty during track tests was determined to cause a similar increase in cycle energy consumption. During constant speed tests only the tire rolling resistance component contributes and is less significant). The aerodynamic drag effect of the random ambient winds present during track tests can be estimated from a procedure developed earlier and reported in Reference 8. Air density, which has a linear effect on the aerodynamic drag component, averaged about 1% greater in the track tests than the dynamometer standard atmosphere conditions. Another variation between the track and the dynamometer tests which may have contributed slightly to the differences is the slower data rate of the track tests which was necessitated by the limited on-board data storage capacity. These effects work to increase the energy consumption measurements from track tests by 2-5% depending on the speed and

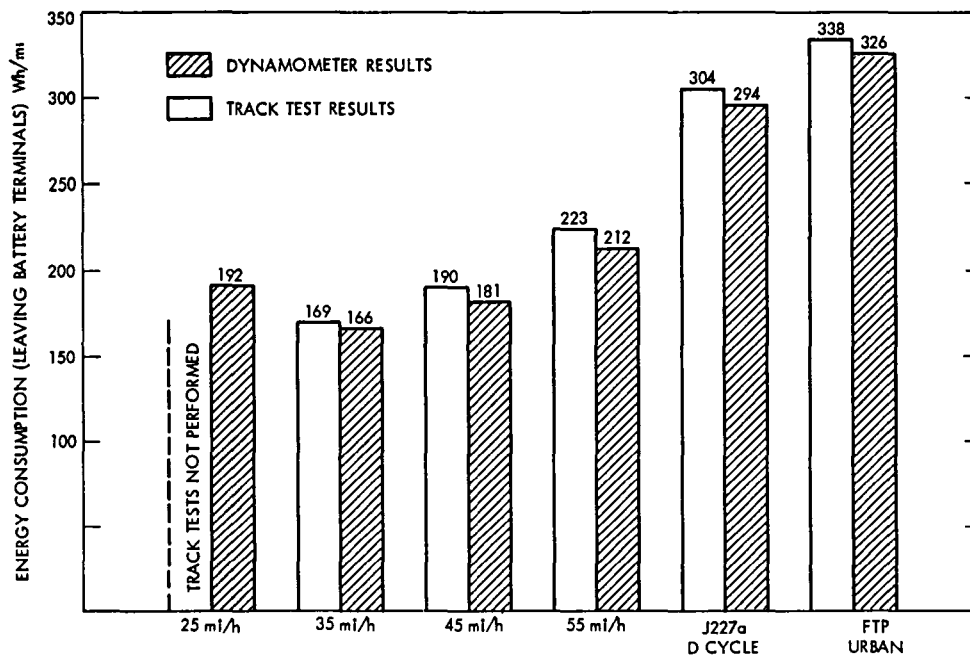

Figure 3-1. ETV-1 Energy Consumption; Correlation of Dynamometer Test Results with Track Test Results

cycle. Applying the appropriate corrections, the track test results move to within approximately 1% of the dynamometer results. This determination clearly demonstrates that over complete tests to battery depletion the JPL procedures for dynamometer calibration and test setup described earlier are valid.

A complete set of energy economy<sup>10</sup> results for all dynamometer and track tests for the ETV-1 in its standard configuration is presented in Figures 3-2a and 3-2b plotted against accumulated distance. The mean value for energy economy for the "D" cycle is 5.326 km/kWh (3.310 mi/kWh) with a standard deviation of 1.4%. Equivalent values for the FTP and the steady speed tests are given in the figure. The good-over-all agreement was not accidental as can be seen from the following discussion.

#### B. SAE J227a-D DRIVING CYCLE

Since the publication of Reference 1, the complete data from the tests have become available which allows detailed comparisons to be made of the various phases within the J227a-D driving cycle (acceleration, cruise, coast and brake).

Figure 3-3 is such a comparison of net battery output energy between dynamometer and track data for the four phases of the SAE J227a-D driving cycle and idle. (Details of this cycle are given in Figure 3-4 and Appendix A). The test runs chosen for comparison were nearest to the averages for the tests from each of the test techniques for the D-cycle. The values shown are, in general, the average of two or more cycles within the same test.

The boundaries between the various phases of two adjacent D-cycles were determined by first examining the motor armature current (see Figures 3-5a and 3-5b) plotted over two cycles and then obtaining more precise time values from the corresponding digital data. These times could then be used to determine the value of any measured experimental parameter (such as net battery output energy) expended during a particular phase of the cycle. Motor armature current was used to define the times because it was the most sensitive to the changes in operating conditions which define the phases of any of the plots available for both track and dynamometer tests.

Within a single test (involving either test technique), the differences between corresponding phases of subsequent cycles were usually about 2% of the energy involved in that phase. An exception was the idle phase where the difference was 8%; however, this amounted to only 0.4 Wh. Thus, the comparisons shown can be considered as generally valid for the D cycle and, by inference, for the Federal Test Procedure as well.

---

<sup>10</sup>Energy economy is the inverse of energy consumption plotted in Figure 3-1.

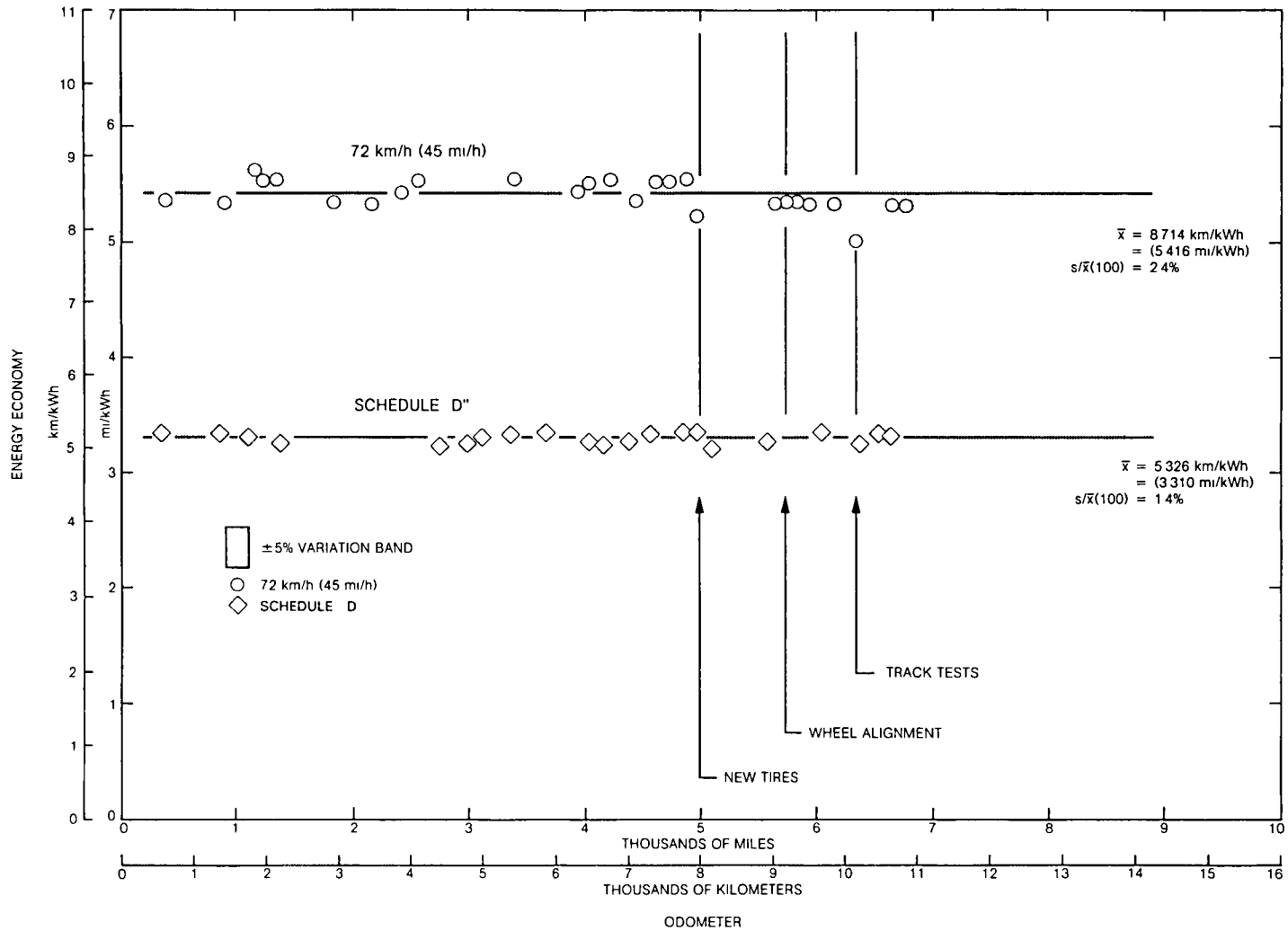

Figure 3-2a. ETV-1 Test Precision: "D" Cycle and 72 km/h (45 mi/h)



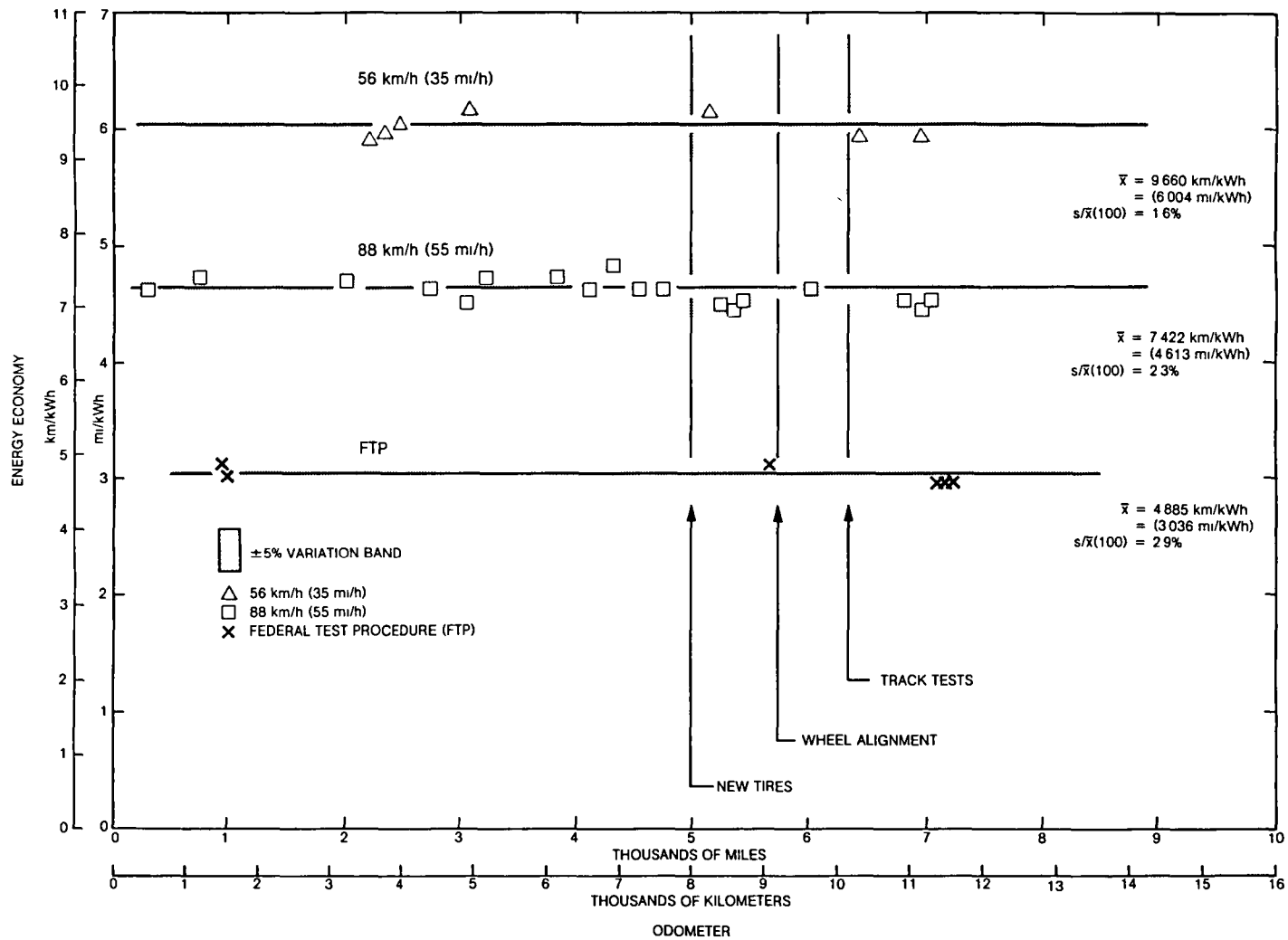

Figure 3-2b. ETV-1 Test Precision: FTP Cycle, 56 km/h (35 mi/h), and 88 km/h (55 mi/h)

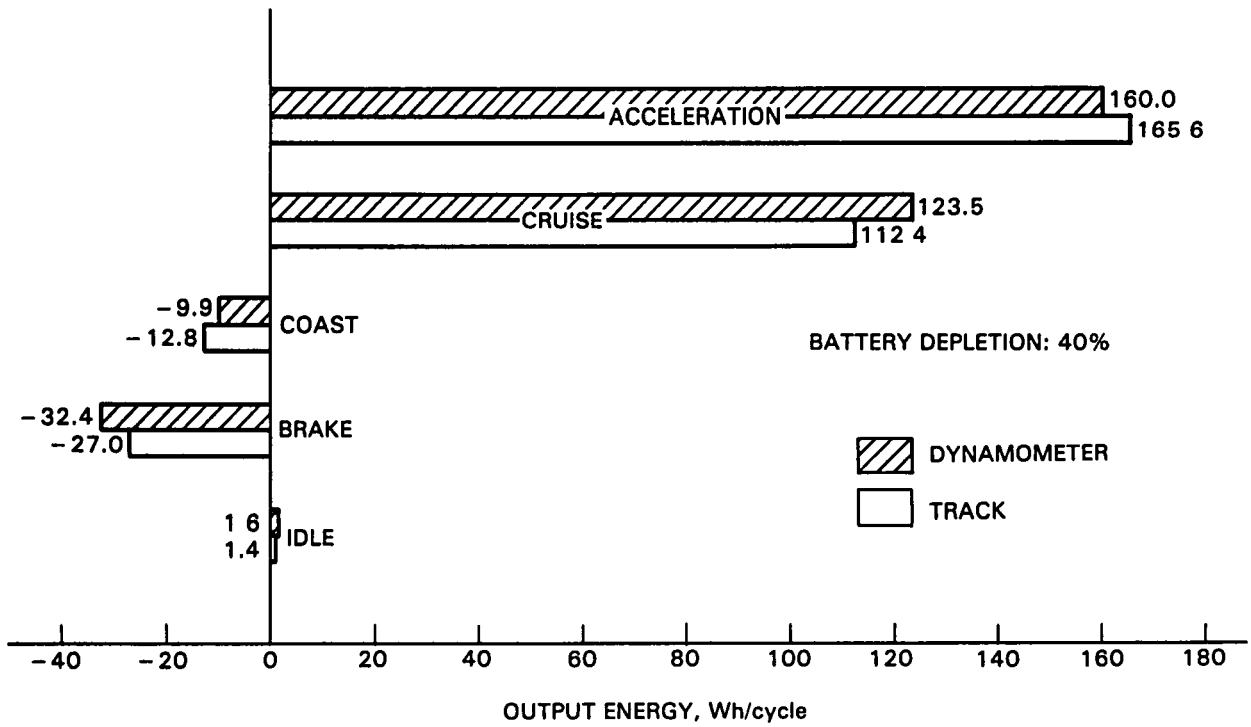

Figure 3-3. SAE J227a-D Driving Cycle Battery Output Energy by Phases

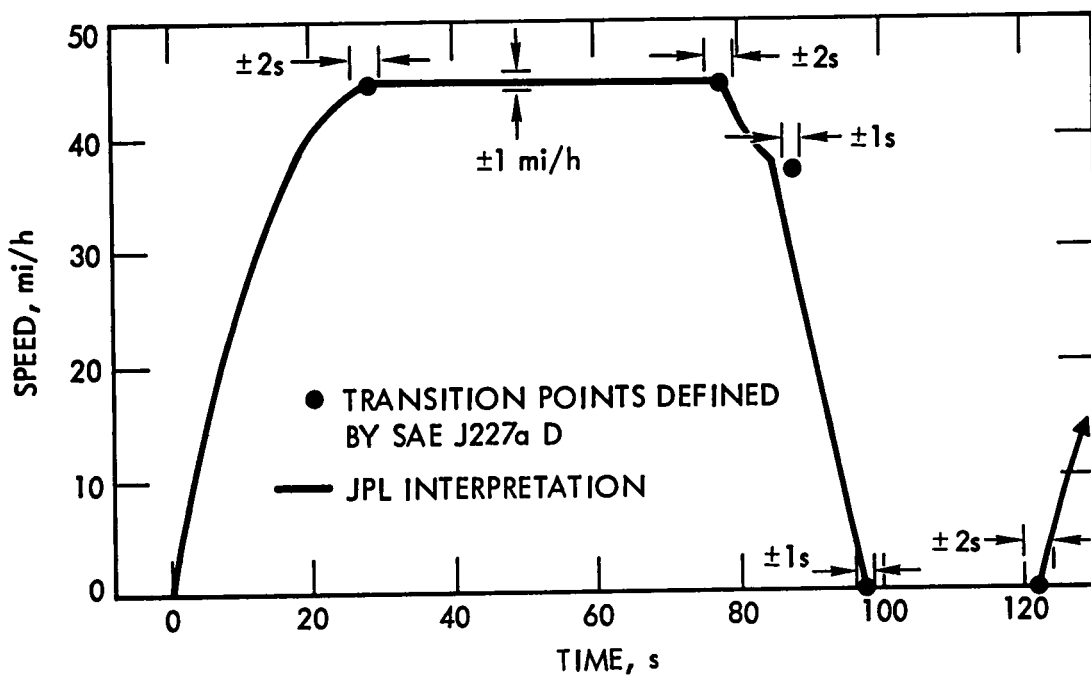

Figure 3-4. JPL Interpretation of the SAE J227a-D Driving Cycle

DYNAMOMETER TEST D CYCLE

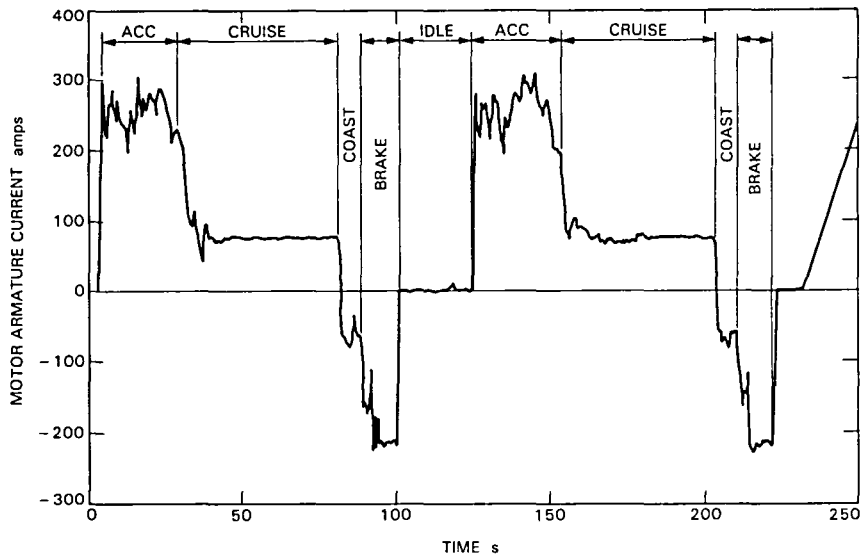

Figure 3-5a. Motor Armature History from Dynamometer Test During SAE J227a-D Driving Cycle

TRACK TEST D CYCLE

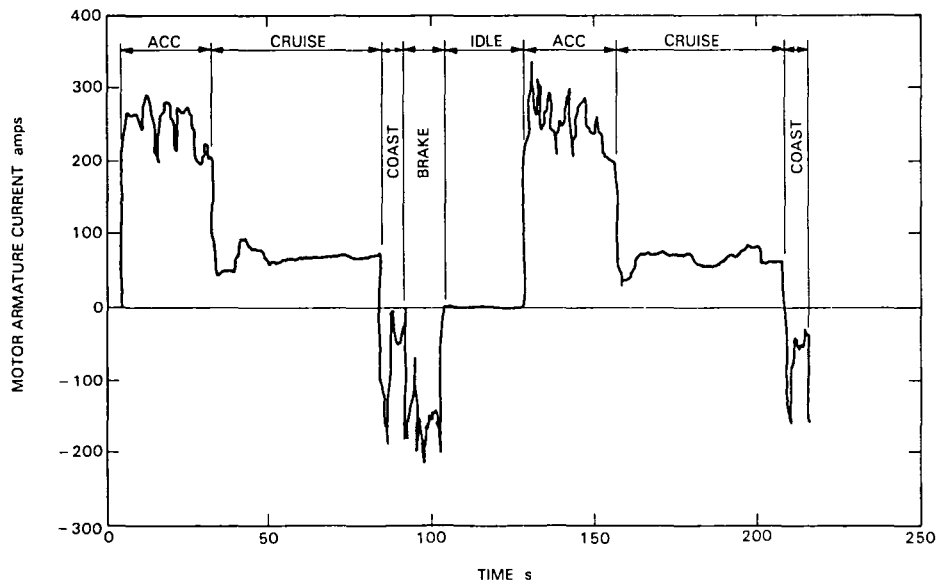

Figure 3-5b. Motor Armature History from Track Test During SAE J227a-D Driving Cycle

As indicated in Table 3-1, the greatest deviation of the dynamometer-measured vehicle energy requirement from the track value by percentage occurred in the coast phase of the D-cycle; the next largest was in the brake phase. The larger deviations for these phases, which are the shortest parts of the cycle, are likely to be due more to a resolution problem resulting from the slow data rate used in the track test than to actual physical differences between the two techniques. The interval between data points was 1 s for the track test and 0.2 s for the dynamometer test. In this particular comparison the differences occurring in the various phases of the D-cycle tended to average out so that the net difference over the complete test was only 1.4%.

Table 3-2 lists the data output, for both testing techniques, which was recorded and analyzed for every test run. Because of the number of data channels and column limitations, data output is presented in three groups:

- (1) General Parameters.
- (2) Energy and Power Parameters.
- (3) Voltages, Currents and Temperatures.

A summary of comparative results for complete tests is presented in Table 3-3 for some of the more important experimental parameters. Data presented here shows only the paired tests, however, a more complete data set was given in Reference 1.

A selection of the more significant vehicle and battery characteristics as well as examples of all types of data recorded is presented as plots in Figures 3-6a through 3-6g. All plots in Figure 3-6 are for the SAE J227a-D driving cycle. These data best illustrate the good agreement between the dynamometer and track tests because of the ability to expand data resolution during the repetitive driving pattern of the J227a-D cycle.

Table 3-1. Deviation from Track Values for Dynamometer-Measured Battery Output Energy (EBO) for Five Phases of the SAE J227a-D Driving Cycle

Cycle Phase	Phase Duration, s	Energy/Phase Track, Wh	Energy/Phase Dynamometer, Wh	Energy Deviation Track-to-Dynamometer, %
Acceleration	28	165.6	160.0	-34.0
Cruise	50	112.4	123.5	9.9
Coast	10	-12.8	-9.9	-22.7
Brake	9	-27.0	-32.4	20.0
Idle	25	1.4	1.6	14.3

Table 3-2. Comparison of Tabulated Output

Part I. General Parameters			Part II. Energy and Power Parameters			Part III. Voltages, Currents and Temperatures		
Parameters	Dyno	Track	Parameters	Dyno	Track	Parameter	Dyno	Track
Time	x	x	Energy out of battery	x	x	Battery voltage	x	x
Velocity	x	x	Energy into battery	x	x	Motor armature voltage	x	x
Distance	x	x	Energy into motor armature	x	x	Motor field voltage	x	x
Dynamometer horsepower	x		Energy into motor field	x	x	Battery current	x	x
Road horsepower	x		Total Ah out of battery	x	x	Motor armature current	x	x
Inertial-weight horsepower	x		Total Ah into battery	x	x	Motor field current	x	x
Aerodynamic horsepower	x		Power out of battery	x		Battery module temperature #1	x	x
Half-axle speed	x	x	Power into battery	x		Battery module temperature #2	x	
Battery power out	x	x	Power into motor armature	x		Battery module temperature #3	x	x
Rolling load	x		Power out of motor armature	x		Battery module temperature #4	x	x
Drive train efficiency	x		Power into motor field	x		Battery module temperature #5	x	x
% Aerodynamic	x		Electric motor speed	x	x	Motor temperature #1	x	x
% Rolling resistance	x					Motor temperature #2	x	x
Air temperature	x	x				Motor temperature #3	x	
Track temperature		x				Controller temperature #1	x	x
Wind speed		x				Controller temperature #2	x	
Wind direction		x				Controller temperature #3	x	
Barometric pressure	x	x				Controller temperature #4	x	
Relative humidity	x	x						

Table 3-3. Summary of the Results Over Complete Tests

Dynamometer							Track					
Test Type	Run No.	Battery Discharge Energy <sup>a</sup>	Range	Energy Economy <sup>b</sup>	Initial Battery Temperature	Final Battery Temperature	Run No.	Battery Discharge Energy <sup>a</sup>	Range	Energy Economy <sup>b</sup>	Initial Battery Temperature	Final Battery Temperature
		kWh	km (mi)	km/kWh (mi/kWh)	°C (°F)	°C (°F)		kWh	km (mi)	km/kWh (mi/kWh)	°C (°F)	°C (°F)
D	14	13.40	73.27 (45.53)	5.47 (3.39)	23.7 (74.6)	33.1 (91.6)	80	13.46	71.54 (44.45)	5.31 (3.30)	23.1 (73.6)	146.1 (90.8)
FTP Urban	9	14.76	72.92 (45.31)	4.94 (3.07)	23.9 (75.0)	34.1 (93.4)	88	14.97	71.18 (44.23)	4.75 (2.95)	24.1 (75.4)	33.4 (92.2)
55 mi/h	74	12.08	89.80 (55.80)	7.44 (4.62)	21.6 (70.8)	26.9 (80.4)	86	12.06	86.04 (53.46)	7.15 (4.44)	23.6 (74.4)	29.4 (85.0)
45 mi/h	75	14.87	127.46 (79.26)	8.56 (5.32)	23.6 (74.4)	28.0 (82.4)	82	14.32	122.31 (76.00)	8.55 (5.31)	22.3 (72.2)	29.6 (85.2)
35 mi/h	22	16.20	155.95 (96.95)	9.62 (5.98)	20.8 (69.4)	25.8 (78.4)	85	16.58	159.07 (98.84)	9.59 (5.96)	22.1 (71.8)	24.1 (75.4)

<sup>a</sup>Total energy removed from battery terminals.

<sup>b</sup>Total energy removed from battery terminals divided by distance driven.

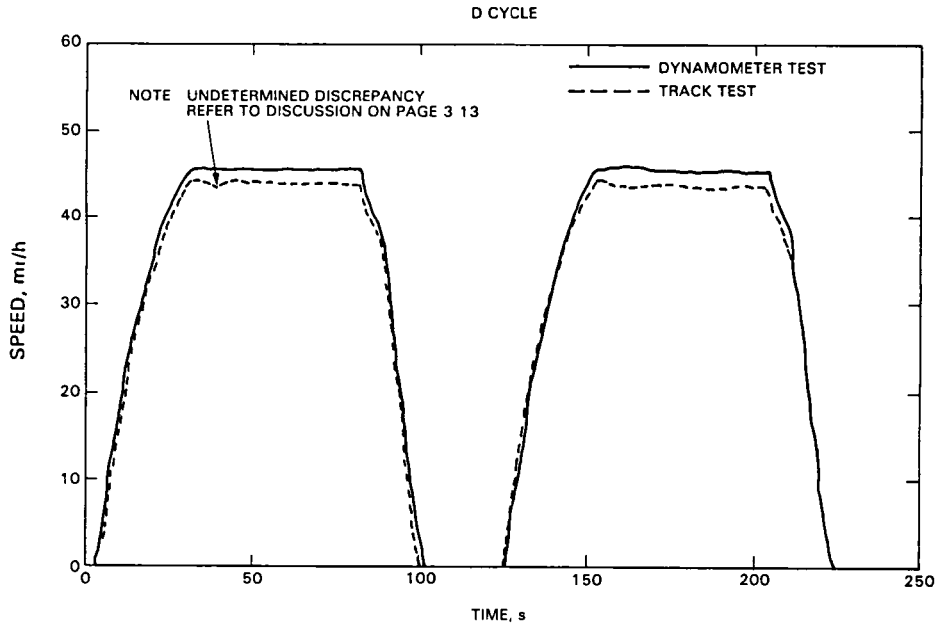

Figure 3-6a. Comparisons Between Track and Dynamometer Tests of Some Significant Test Parameters for the SAE J227a-D: Vehicle Speed

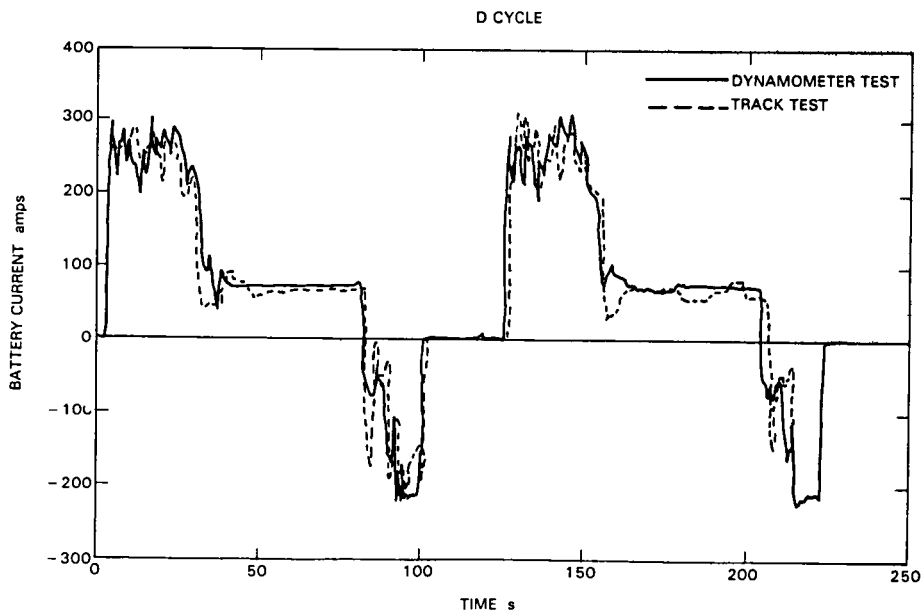

Figure 3-6b. Battery Current

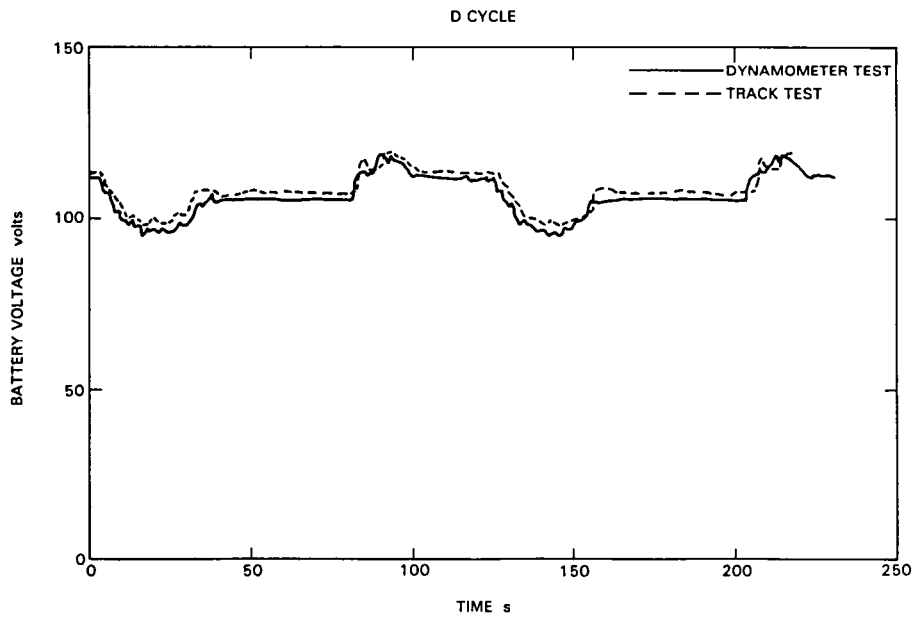

Figure 3-6c. Battery Voltage

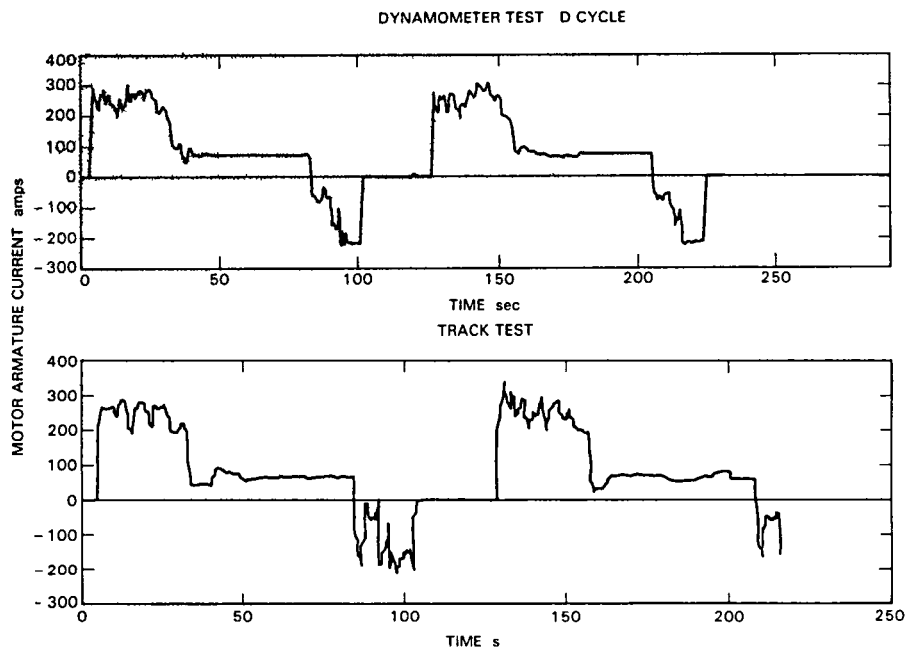

Figure 3-6d. Motor Armature Current



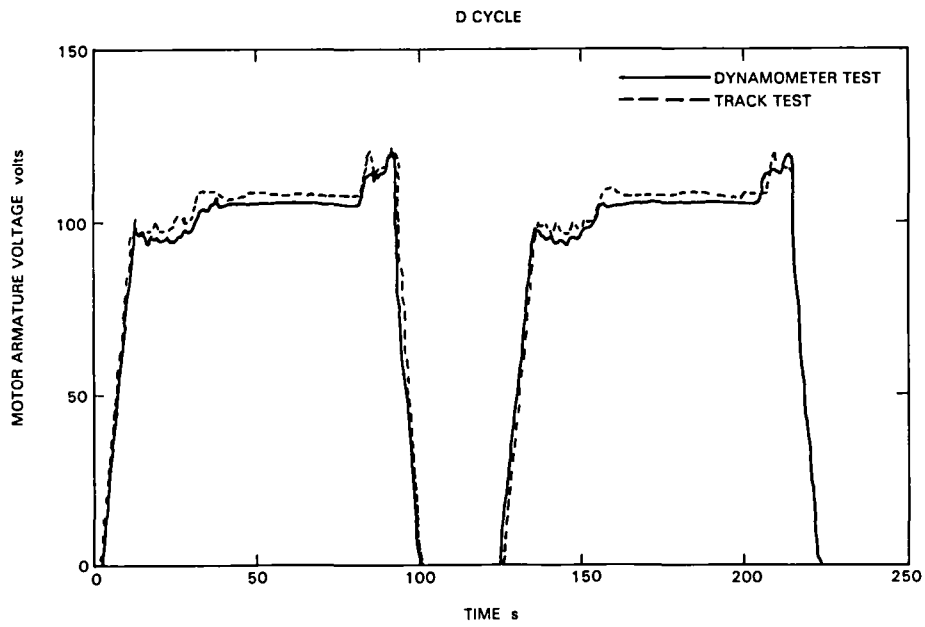

Figure 3-6e. Motor Armature Voltage

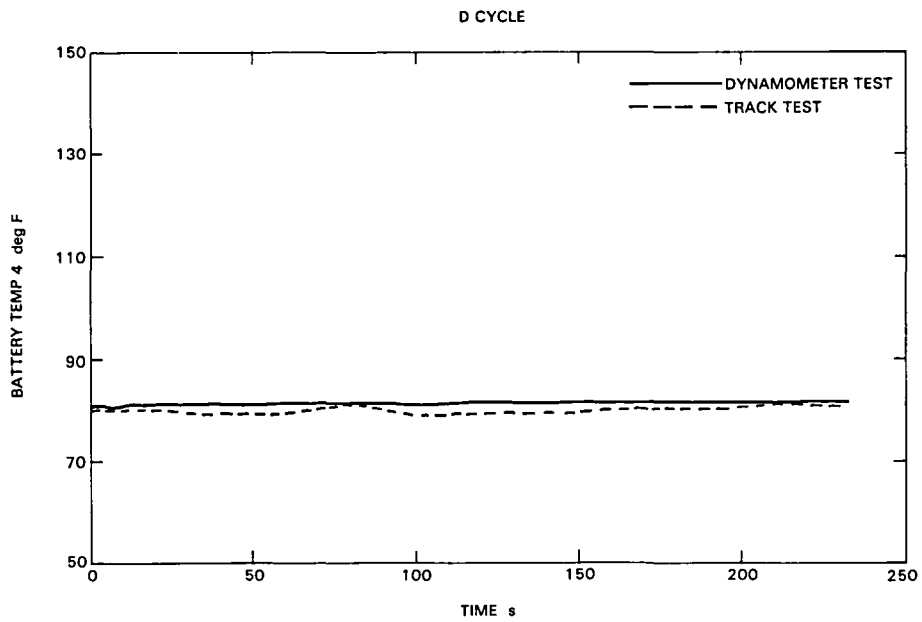

Figure 3-6f. Representative Battery Temperature

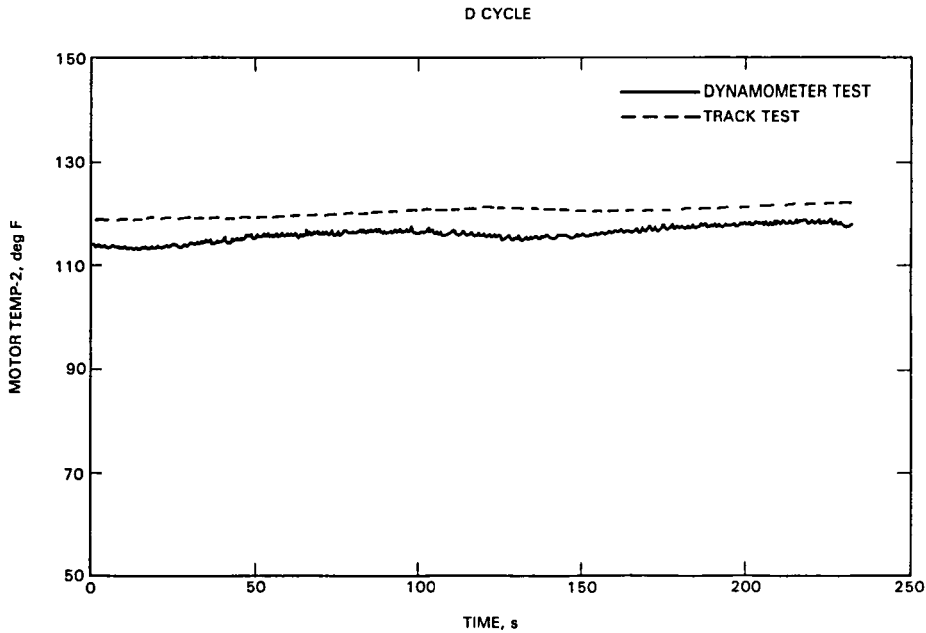

Figure 3-6g. Representative Motor Temperature

A slight exception to the generally good agreement between the two test techniques are the velocity versus time plots such as Figure 3-6a where there is an apparent discrepancy of about 1.6 mi/h in the constant velocity portion of the D-cycle data. This appears to be an undetermined problem with a scaling factor in the reduction of the velocity data from the track tests since the distance traveled during a single D cycle is in consistent agreement.

The same parameters have been plotted for the D-cycle in Figures 3-6a through 3-6g and for the other tests in Appendix B. They are:

- a - vehicle speed
- b - battery current
- c - battery voltage
- d - motor armature current
- e - motor armature voltage
- f - representative battery temperature
- g - representative motor temperature

Due to the large number of test parameters, data are not always recorded continuously. During most of the testing, slices of data are acquired at various time intervals. The exact time within the test depends on the type of test. For instance, during constant-speed tests, data were recorded once every 30-s interval. During the driving schedule tests the 30-s interval data are supplemented by several continuous recordings of two complete repetitions of the driving cycle (Figure 3-7). These continuous recordings are intended to occur at four discrete levels of battery DoD; however, the time at which these DoDs occur must be estimated before test initiation. Because of the

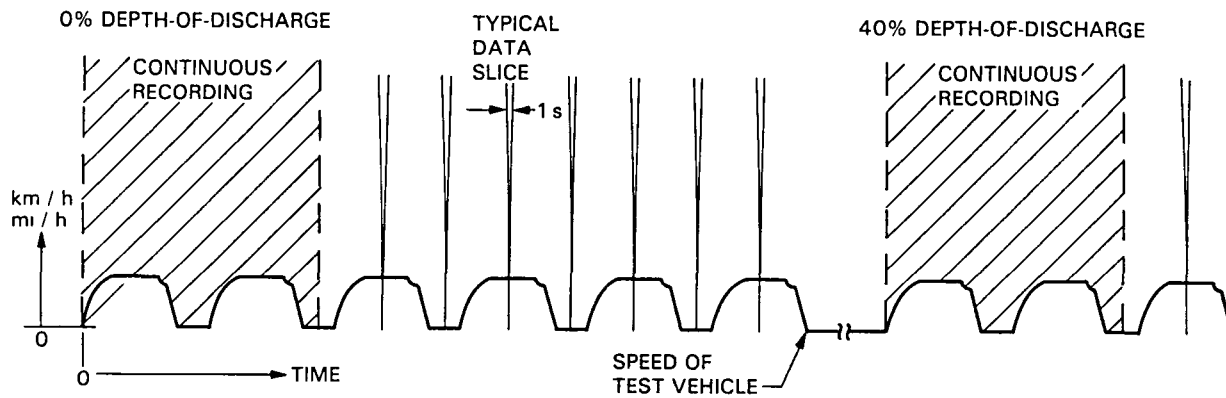

Figure 3-7. Typical Data Recording Format, Vehicle Velocity Versus Recording Period

uncertainties associated with this estimating process. data indicated as occurring at various DoDs may actually have been recorded slightly before or after that specified.

Data recording was accomplished in two ways: high-speed printer (on paper) and magnetic tape. The bulk of the recording was done with the magnetic tape while the direct printing was used for a "quick look" immediately after test completion. Subsequent data reduction of the magnetic tapes provided a detailed tabular printout of the data as well as plots of pertinent parameters. Similar plots for the FTP Urban Driving Cycle and steady speed tests at 56, 72 and 89 km/h (35, 45 and 55 mi/h) are included in Appendix B. It is this high-rate data which is shown in Figures 3-6a through 3-6g. The time scales have been shifted so that the initiation of the first cycle occurred at the origin and the plot ordinates have been shifted in order to facilitate comparisons between the two techniques (i.e., track versus dynamometer). It is worthy of note that agreement between the two test techniques is good, even at this detailed level. for all parameters measured.

Figure 3-8 which is a plot of battery current versus time at 56 km/h (35 mi/h) illustrates a slow oscillatory effect common to the vehicle power data for steady-speed tests performed on the track. The oscillation is clearly a track effect. due to track grade since the period of the oscillation is

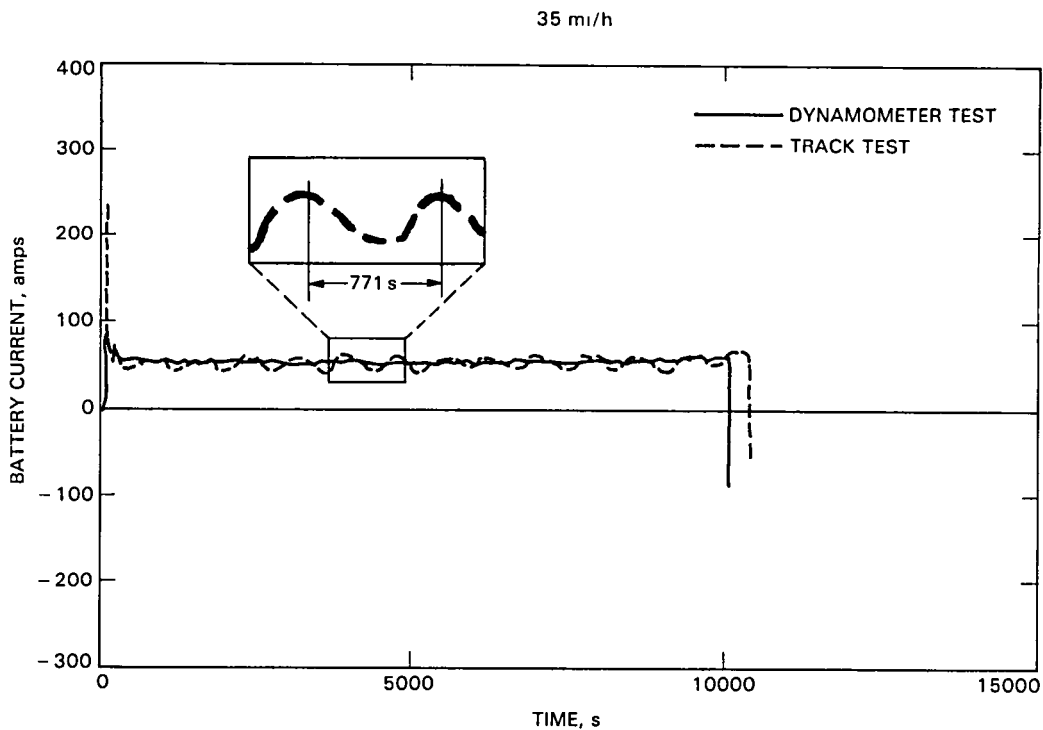

Figure 3-8. Battery Current Versus Time for Track and Dynamometer Tests

directly related to the length of the oval track.<sup>11</sup> Additional confirmation as to the grade effects on battery current is obtained by comparing the amplitude of the current oscillation to the known variations in track slope. The opposing (or aiding) force created by the measured track slope is consistent with the increased (or decreased) battery current requirements. The small, shorter variations in battery current (during track tests) is attributed to ambient winds and driver reactions to changes in vehicle speed caused by variations in track gradients.

---

<sup>11</sup>The expanded segment of Figure 3-8 illustrates that the current withdrawn from the batteries has a period of approximately 771 s. At 35 mi/h this corresponds to 7.5 mi which is the length of the test track. Reference 8 indicates that this track has an average slope of 0.228 percent over the length of its oval shape.

## SECTION IV

### CONCLUDING REMARKS

It has been demonstrated that the chassis dynamometer, when used under carefully-controlled test conditions and supported by road-load information obtained from careful coastdown tests, can produce electric vehicle performance data which is in good agreement with track test data on the same vehicle. This good agreement for both cyclic and steady-speed tests comes about because the dynamometer test technique is able to closely match track performance under acceleration, cruise, coast and braking operating conditions.

The following individual points are concluded from the EV Dynamometer Test Procedure and Track Correlation Effort:

- (1) The relatively inexpensive Clayton twin-roll chassis dynamometer does a very good job of emulating vehicle road-load requirements when rolling and aerodynamic losses are accounted for separately. Good road-load simulation occurs over a wide range of vehicle speeds and only requires the addition of inexpensive hardware.
- (2) Sufficient vagueness exists in the SAE J227a procedures that meaningful comparisons of electric vehicle components are improbable without further definition.
- (3) In addition to controlling ambient temperature in dynamometer facilities, electrolyte temperature must also be controlled to obtain consistent test results. This is especially true in the case of lead-acid batteries.
- (4) Lead-acid battery-pack capacity, when aging effects are ignored, generally repeats within +2% (for a given discharge rate) when adequate charging and temperature controls are incorporated into the EV test procedures.

## SECTION V

### RECOMMENDATIONS

Considerable improvement in making the EV test engineering data more meaningful and valid is possible by strengthening the specificity of the J-227a procedure. It is therefore recommended that the SAE J227a procedure be reviewed for the purpose of minimizing test variability due to non explicit procedures. The approaches used by JPL should provide a good basis for this review.

While the suggested refinements will greatly improve the quality of engineering data, the testing does not represent how people actually drive. In other words, the data derived from the SAE J227a procedures cannot be used to present a nominal value of energy economy or vehicle range under typical driving conditions. To alleviate this shortcoming, it is recommended that the EPA Urban Driving Schedule be used to provide nominal range and economy estimates. These numbers would be comparable to the "sticker" values now found on the windows of new vehicles. Although it is recognized that the Urban Cycle does not correlate perfectly with the habits of the average driver, it is a step in the right direction and is well accepted in that sense.

As a further step toward the goal of establishing realistic performance characteristics under everyday operating conditions, realistic charging conditions should be included as a part of the test procedure. For example, equalization charging would not normally be carried out on a routine basis, nor would batteries be soaked to a predetermined temperature.

## SECTION VI

### REFERENCES

1. Kurtz, D.W., The DOE ETV-1 Electric Test Vehicle, Phase III Final Report, Performance Testing and System Evaluation, JPL Publication 81-93, December 1981.
2. Society of Automotive Engineers, Inc. Recommended Practice, "Electric Vehicle Test Procedure-SAE J227a," Warrendale, PA., February, 1976.
3. Marte, J.E. et al., "A Study of Automotive Aerodynamic Drag," DOT-TSC-OST-75-28, September 1975.
4. White, R.A. and Korst, H.H., "The Determination of Vehicle Drag Contributions from Coast Down Tests," SAE Paper No. 720099, January 1972.
5. Dayman, Jr., B., "Tire Rolling Resistance Measurements from Coast-Down Tests," SAE Paper No. 760153, February 1976.
6. Price, T., et al., Vehicle Test Report: South Coast Technology Rabbit, JPL Publication 81-28, July 1980.
7. Griffin, D.C., Bryant, J.A., "Data Acquisition System for Electric Vehicle Tests", Proceedings of IAS Annual Meeting, IEEE Industry Applications Society, September 1980.
8. Dustin, M.O., Slavic, R.J., "On the Road Performance Tests of Electric Test Vehicle for Correlation with Road Load Simulator," NASA TM-82900, August 1982.

## APPENDIX A

### SAE J227a Driving Cycle Testing at JPL

Initial tests of electric vehicles (EVs) at the JPL Automotive Research Facility revealed a considerable degree of test-to-test variability due to the non-specificity of the widely used SAE Recommended J227a Test Procedure. Furthermore, conversations with various EV manufacturers indicated that interpretation of the driving schedules varied significantly throughout the EV industry. It became imperative that unspecified variables be minimized to preclude the possibility of masking the desired battery comparisons. To assure reasonable test precision and to allow fair comparisons of these batteries, the need to completely specify the driving schedules was felt to be a prerequisite to serious testing.

Definition of specific velocity-time profiles for each of the J-227a driving schedules were established using the following basic criteria:

1. Driving profiles should satisfy the letter of the J-227a procedures as closely as possible.
2. Profiles should reflect what the "average" driver would expect to see as JPL could best identify from other established test schedules and DOE-sponsored surveys of EV users.
3. The selected profile should not specifically penalize a given EV design (for instance, reasonable levels of regeneration should be allowed.)

In formulating these JPL-standardized driving profiles it was recognized that their characteristics may not meet with wide acceptance in the EV test community. Furthermore, there was no intent to infer that any other version of these cycles was inferior. These cycles were implemented internal to JPL solely to minimize test-to-test and driver-to-driver variability within the JPL EV test program. Even though one of the criteria used in refining the J-227a profiles was to match it to the average driver the resulting profiles do not reflect average driving. The opening statements in the SAE procedure indicate that the driving schedules were formulated only to provide a basis for comparison and were not designed to be indicative of how people actually drive. The "how people actually drive" criterion was used to temper the JPL interpretation of the basic J-227a procedure, not to modify it. Compared to test results obtained when using the Environmental Protection Agency's (EPA) Urban driving schedule, delineated in the Federal Test Procedure (FTP), all of the J-227a driving schedules provide optimistic range (battery capacity) and energy economy test results.

What follows is a presentation of the "standardized" J-227a driving schedules used at JPL and a brief discussion of the rationale used in defining each segment within them. With the exception of the split between "coast" and "brake" in the schedule "D" cycle, the J-227a specifications of time versus speed remain as detailed by the SAE.



Tabulated values of speed versus time for Schedules "B", "C", and "D" are presented in Tables A-1, A-2 and A-3, respectively. Figure A-1 is a plot of these tables.

#### "B" and "C" SCHEDULES

- o Accelerations - The accelerations are an average of the acceleration profiles used in the FTP Urban driving cycle normalized to the appropriate time constraints of the J227a. This closely approximates a constant power acceleration. The primary reason for choosing this particular acceleration profile is it fairly represents how most consumers operate their vehicles.
- o Cruise - Cruise is a constant-speed operation at whatever speed and for whatever duration specified in the J227a.
- o Coast - The general feeling, was that electric vehicles should coast at a rate about equal to that of conventional cars. Therefore, the "coast" appearing in the attachments reflects this thinking.  
  
Brake - The beginning of this phase of the driving schedules is controlled by the terminal velocity of the "coast". Since the end point of the "brake" is also fixed (assuming a linear deceleration rate). Increasing the velocity at which braking is initiated (as was done by using a coast rate equal to that from conventional vehicles) dictates higher deceleration rates because the braking interval does not change. The modifications to braking, imposed by the changes in "coast" have been incorporated in the attached details of the "B" and "C" schedules.

#### "D" SCHEDULE

The recommended "D" schedule is summarized below. Following the summarization is a discussion of the considerations and rationale leading to the recommended "coast-brake" portion of the "D" cycle.

- o Acceleration - Same as in "B" and "C" Schedules above.
- o Cruise - Same as in "B" and "C" Schedules.
- o Coast - Coasting will be done at a rate equal to that for a conventional vehicle (i.e., the same criterion used for "B" and "C" cycles). However, the coast time specified by the J-227a will be reduced approximately 3 seconds. This reduction will be used to extend the braking by an equal increment, (thus keeping the total coast-brake time the same as called out in the J-227a). This allows the braking deceleration rate to be less than the 3.3 mi/h/s maximum rate. Coast duration will arbitrarily be limited to the closest whole second which yields a brake deceleration rate of 3.3 mi/h/s or less.
- o Brake - Using the above "coast" philosophy, braking will occur at a deceleration rate of 3.17 mi/h/s. In the same manner as for the "B" and "C" cycles, braking is specified as a linear rate until the vehicle comes to a complete stop. These changes are reflected in the attached "D" Schedules.

The recommended "coast-brake" schedule was arrived at after the following thought processes. The basic problem was as follows:

- (1) If the same coast criterion as adopted for the "B" and "C" cycles is employed for the "D" cycle then the rate of braking exceeds the 3.3 mi/h/s limit, (Note that the 3.3 mi/h/s is somewhat arbitrary.) or the total brake time is longer than allowed by J-227a if the 3.3 mi/h/s limit is observed.
- (2) The 3.3 mi/h/s limit leads to either a shortened coast time or a coast deceleration rate greater than chosen for the "B" and "C" cycles and greater than that observed for conventional vehicles.

A self-imposed, maximum braking rate of 3.3 mi/h/s has been assumed. It is believed that this is the same limit adopted by the EPA for the Federal Test procedure and may reflect dynamometer limitations. A modest effort was made to verify this assumption, but was unsuccessful. However, it is clear that 3.3 mi/h/s is not derived from a consideration of driver comfort and is nowhere near to the onset of skid of a vehicle. Rates somewhat higher, approximately 5 mi/h/s, can be used on the dynamometer, but above that limit there is a problem with tire slippage on the rolls.

Between General Motors, Ford and Chrysler, at least ten separate track test procedures exist. Although these procedures are usually not used for dynamometer testing, they do provide some guidance on "coast" and "brake". Coast is defined in all these procedures as closed throttle (CT) and, typically, is simply regarded as a part of the braking portion of the procedure. Braking is always done linearly, at least for the procedures reviewed, unless it is a foot-off-the-brake and foot-off-the-throttle deceleration. Most of the procedures use multiple braking rates; the highest being 6.8 mi/h/s in the Ford Suburban cycle and the slowest being 0.7 mi/h/s for the Chrysler Interstate cycle. The average braking rate for all ten cycles is 2.8 mi/h/s which is considerably less than the 3.3 mi/h/s maximum proposed here.

Another SAE Procedure for fuel economy measurements specified all braking to be at linear rate of approximately 2.7 mi/h/s. The rationale for the SAE rate is based on a survey of actual braking rates in five major cities. Average braking, as reported by the survey, is a function of vehicle speed and varies from less than 1 mi/h/s at 45 mi/h to 3.5 mi/h/s at 8 mi/h.

All of the well-known dynamometer procedures are for the purpose of exhaust emission testing. The highest braking rate is 3.4 mi/h/s in the European cycle which is only slightly faster than the 3.3 mi/h/s found in the Federal Test Procedure. The average braking rate for these six dynamometer procedures is 3.1 mi/h/s.

All of the above leads to the conclusion that a brake deceleration rate of 3.3 mi/h/s is a reasonable one to choose and the rate of 4.11 mi/h/s implied for the "D" cycle is too high. A 3.3 mi/h/s rate is in reasonable agreement with what drivers actually use and falls within the range of rates used in other dynamometer procedures.

Table A-1. Time Versus Speed  
SCHEDULE "B"

TIME (sec)	SPEED (mi/h)	TIME (sec)	SPEED (mi/h)	TIME (sec)	SPEED (mi/h)
0	0.00	21	20.00	51	0.00
1	1.67	22	20.00	52	0.00
2	3.35	↓	↓	↓	↓
3	5.03	↓	↓	↓	↓
4	6.71	↓	↓	↓	↓
5	8.28	36	20.00	70	0.00
6	9.78	37*	20.00	71	0.00
7	11.06	38	20.00	72*	Repeat Cycle starting at 0 sec
8	12.28	39	19.20		
9	13.40	40	18.60		
10	14.43	41*	18.20		
11	15.36	42	18.00		
12	16.20	43	14.40		
13	16.97	44	10.80		
14	17.65	45	7.20		
15	18.26	46*	3.60		
16	18.80	47	0.00		
17	19.26	48	0.00		
18	19.66	49	0.00		
19*	20.00	50	0.00		
20	20.00				

\*Denotes transition points from one mode to another (i.e., acceleration to cruise etc.)

Table A-2. Time Versus Speed  
SCHEDULE "C"

TIME (sec)	SPEED (mi/h)	TIME (sec)	SPEED (mi/h)	TIME (sec)	SPEED (mi/h)
0	0.00	21	30.00	54	2.89
1	2.65	↓	↓	55	0.00
2	5.31	↓	↓	56	0.00
3	7.97	↓	↓	57	0.00
4	10.60	37	30.00	58	0.00
5	13.05	38*	30.00	59	0.00
6	15.28	39	29.19	60	0.00
7	17.33	40	28.45	↓	↓
8	19.18	41	27.89	↓	↓
9	20.89	42	27.40	78	0.00
10	22.43	43	26.98	79	0.00
11	23.83	44	26.59	80*	Repeat Cycle
12	25.08	45	26.27		
13	26.21	46	26.00		
14	27.20	47	23.11		
15	28.07	48	20.22		
16	28.82	49	17.33		
17	29.45	50	14.44		
18*	30.00	51	11.56		
19	30.00	52	8.67		
20	30.00	53	5.78		

\*Denotes transition points from one mode to another (i.e., acceleration to cruise etc.)

Table A-3. Time Versus Speed  
SCHEDULE "D"

TIME (sec)	SPEED (mi/h)	TIME (sec)	SPEED (mi/h)	TIME (sec)	SPEED (mi/h)
0	0.0	25	43.31	91	19.00
1	2.56	26	43.93	92	15.83
2	5.12	27	44.49	93	12.67
3	7.68	28	45.00	94	9.50
4	10.24	29	45.00	95	6.33
5	12.80	30	45.00	96	3.17
6	15.36			97	0.00
7	17.79	↓	↓	98*	0.00
8	20.08			99	0.00
9	22.24	75	45.00	100	0.00
10	24.28	76	45.00	↓	↓
11	26.20	77	45.00		
12	28.01	78*	45.00	120	0.00
13	29.72	79	43.53	121	0.00
14	31.34	80	42.33	122*	Repeated cycle
15	32.85	81	41.33		Starting at 0
16	34.27	82	40.40		sec
17	35.60	83	39.53		
18	36.85	84	38.73		
19	38.01	85*	38.00		
20	39.09	86	34.83		
21	40.08	87	31.67		
22	41.00	88	28.50		
23	41.85	89	25.33		
24	42.61	90	22.17		

\*Denotes transition points from one mode to another (i.e., acceleration to cruise, etc.)

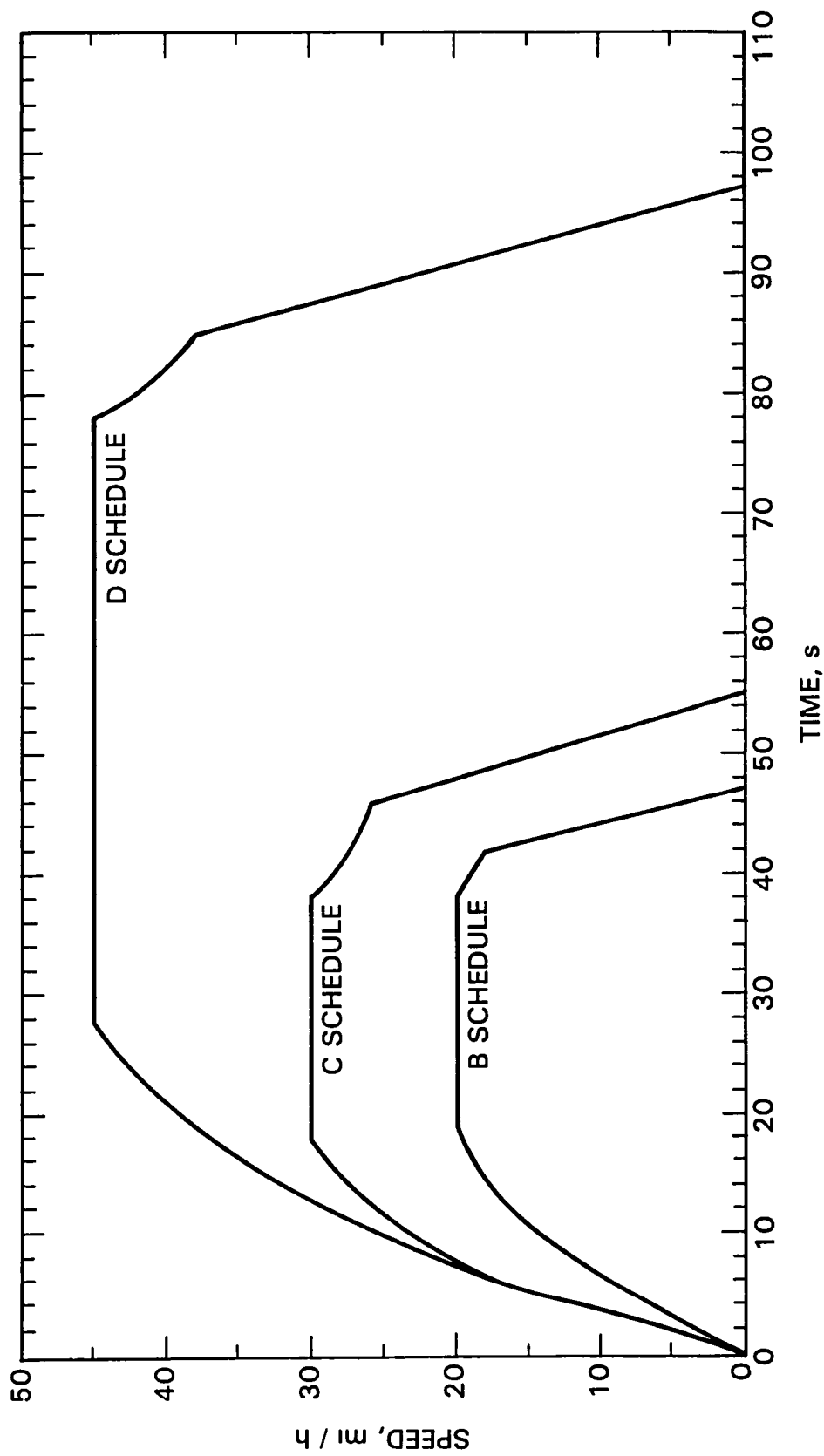

Figure A-1.

## APPENDIX B

### VEHICLE AND BATTERY CHARACTERISTICS FOR FTP URBAN DRIVING CYCLE AND STEADY-SPEED TESTS AT 56, 72 and 89 km/h (35, 45 and 55 mi/h)

#### A. FEDERAL TEST PROCEDURE URBAN DRIVING CYCLE

In addition to the SAE J227a-D driving cycle, a comparison between the track and dynamometer test techniques has been made for the Urban Driving Cycle of the Federal Test Procedure. This cycle was developed from the record of a trip which included surface street and freeway segments. It is, therefore, much more complex (see Fig. B-1) than the SAE J227a-D cycle and the technique comparison can be made only on an overall basis. The comparisons are presented in Fig. B-2. These plots show the entire tests run to battery depletion which consisted of more than six of the cycles shown in Fig. B-1. No detailed comparisons of the characteristics plotted will be made but it can be noted that the form and values of the curves are in general agreement between the track and dynamometer data. Therefore, it is not surprising that the integrated results shown in Fig. 3-1 are in reasonable agreement between the track and dynamometer tests.

#### B. STEADY SPEED TESTS

The steady-speed test comparisons are shown in Fig. B-3 for 89 km/h (55 mi/h); Fig. B-4 for 72 km/h (45 mi/h) and Fig. B-5 for 56 km/h (35 mi/h). The summary of data over the entire tests is included with the cyclic data in Table 3-2. Throughout the plots of the three steady-speed tests it is evident that the general agreement between comparable tests is good in terms of both curve shape and absolute data. The differences in duration of the tests which proceed to battery depletion results from the past usage and charging of the battery rather than from any inherent technique effect. In the steady-speed tests the track data is noticeably more noisy than the dynamometer data. This is probably due to the rougher ride on the track relative to the dynamometer. In both instances 10 kHz filtering was applied to the data. In these three figures the origins were again shifted for easier comparison as described earlier.

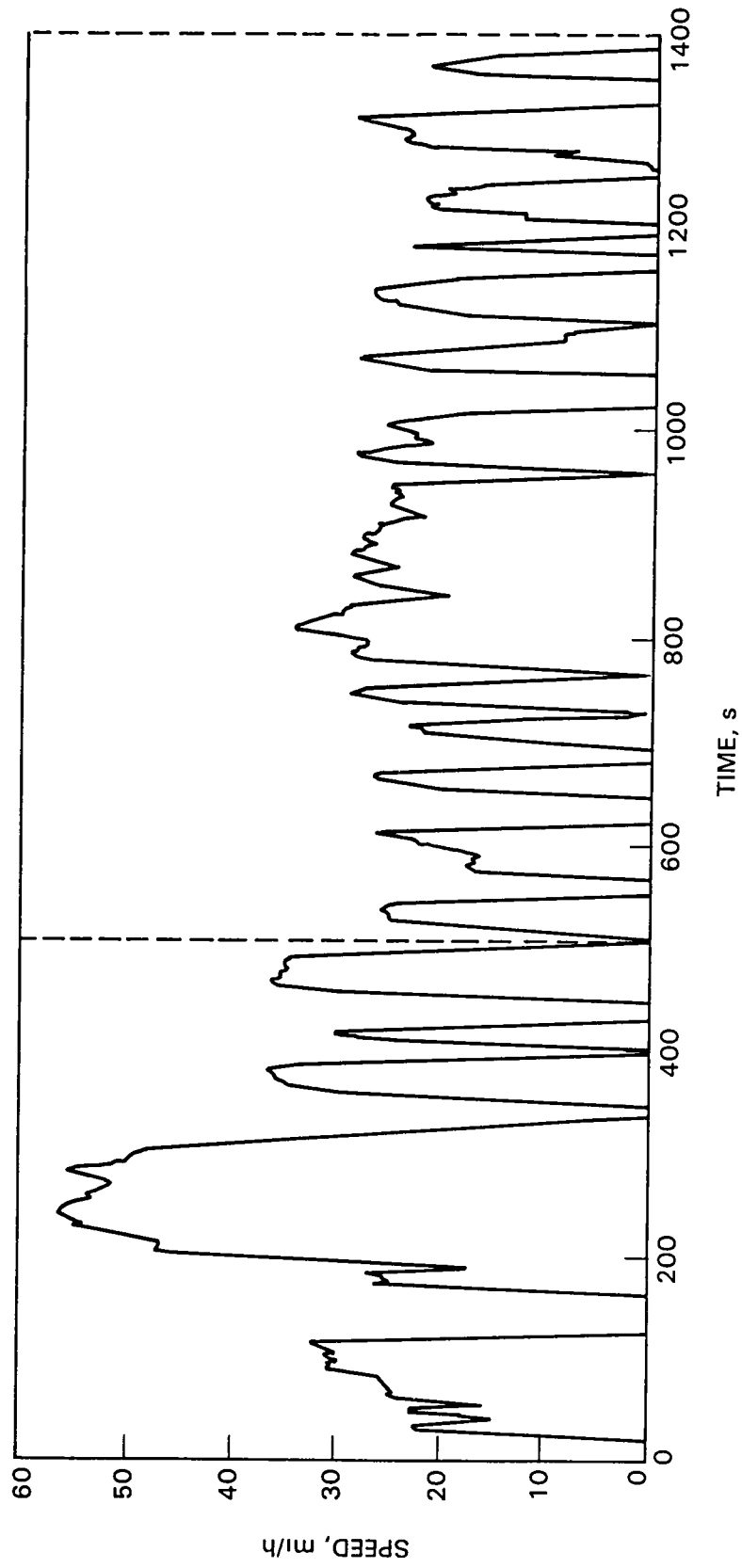
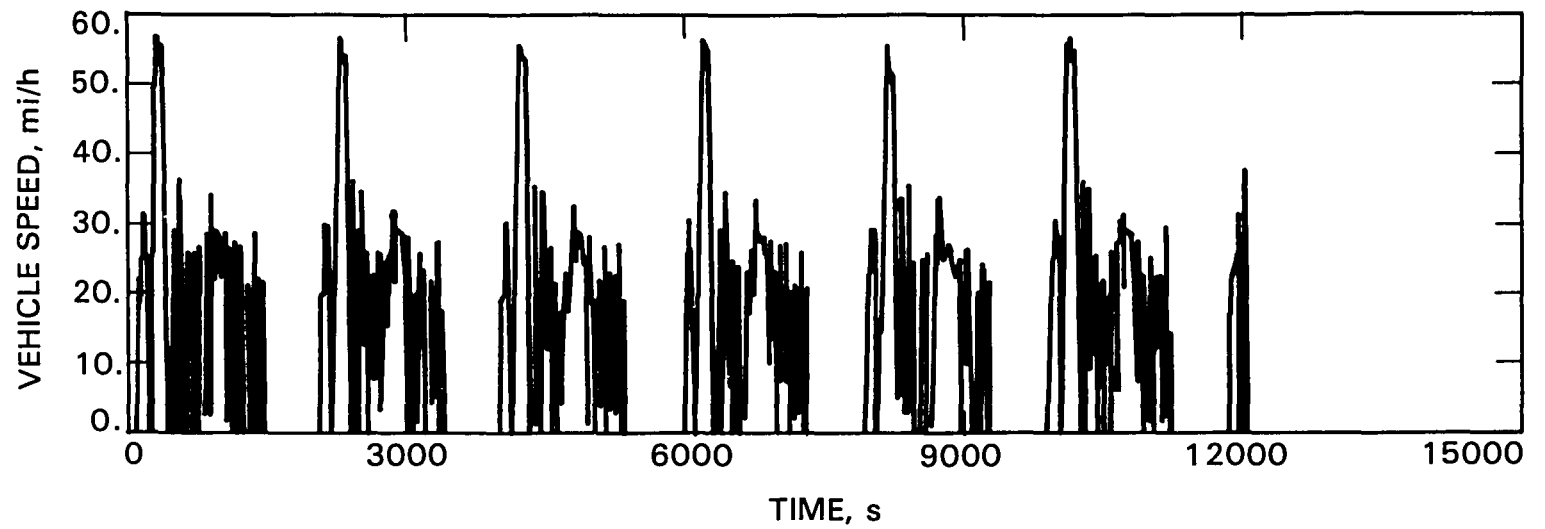

Figure B-1.



FTP  
DYNAMOMETER TEST



TRACK TEST

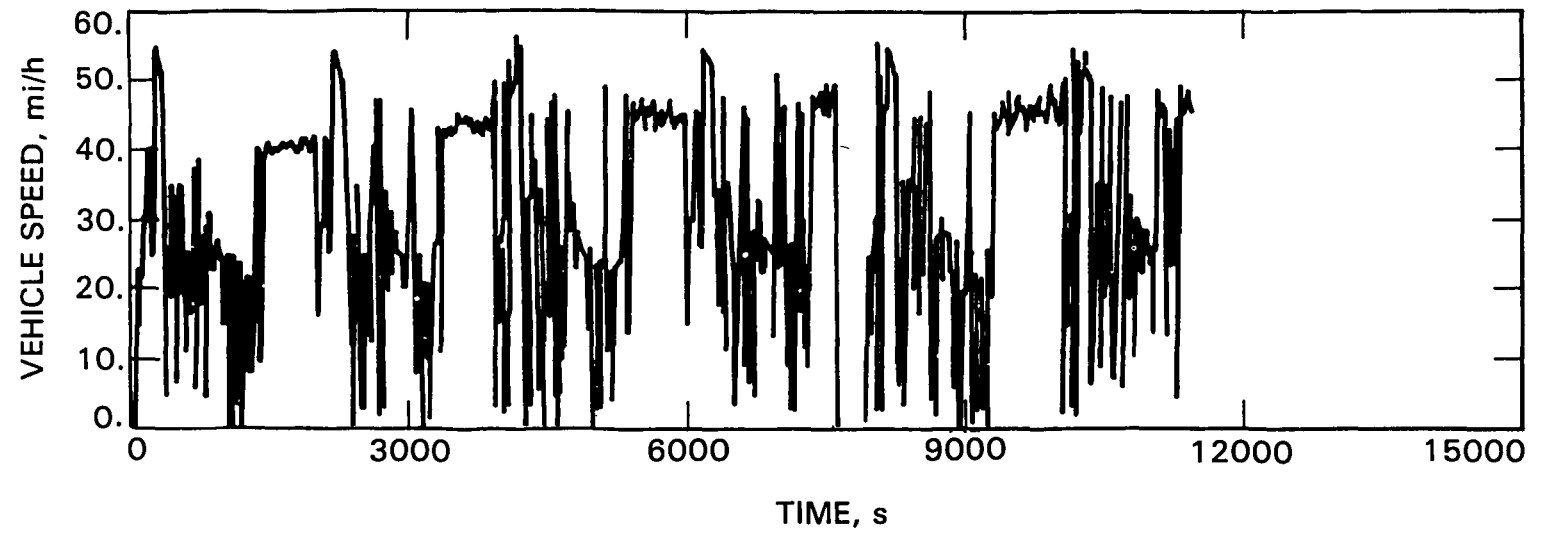
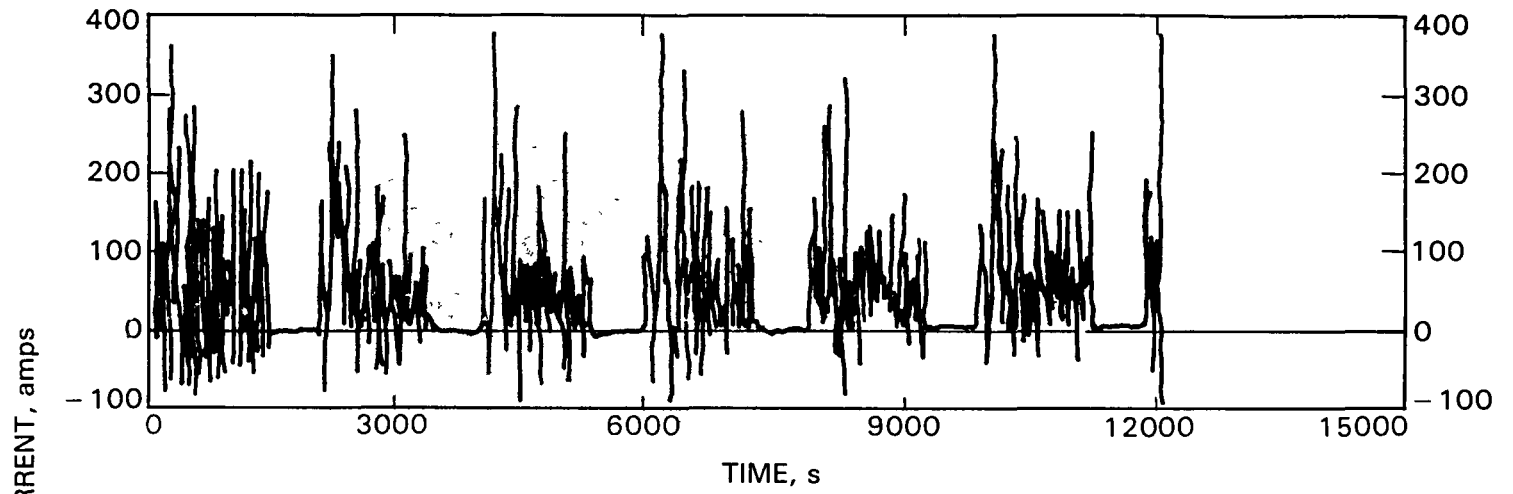

Figure B-2a.

B-3

FTP  
DYNAMOMETER TEST



TRACK TEST

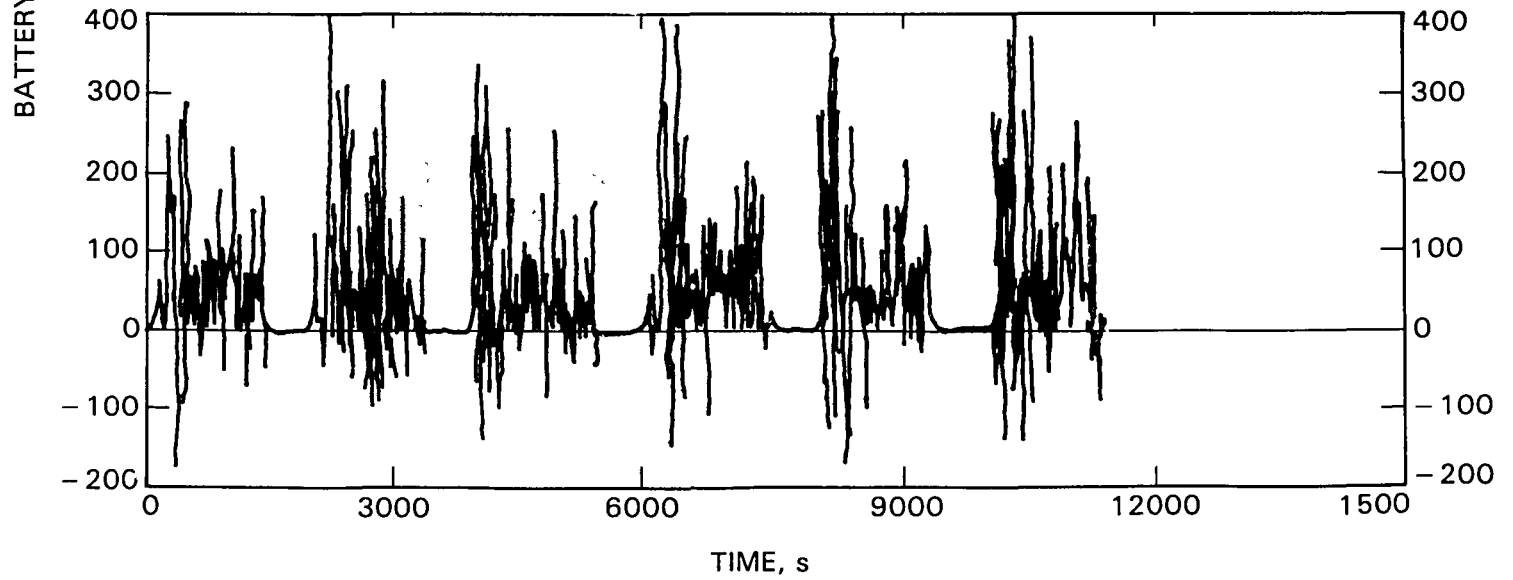
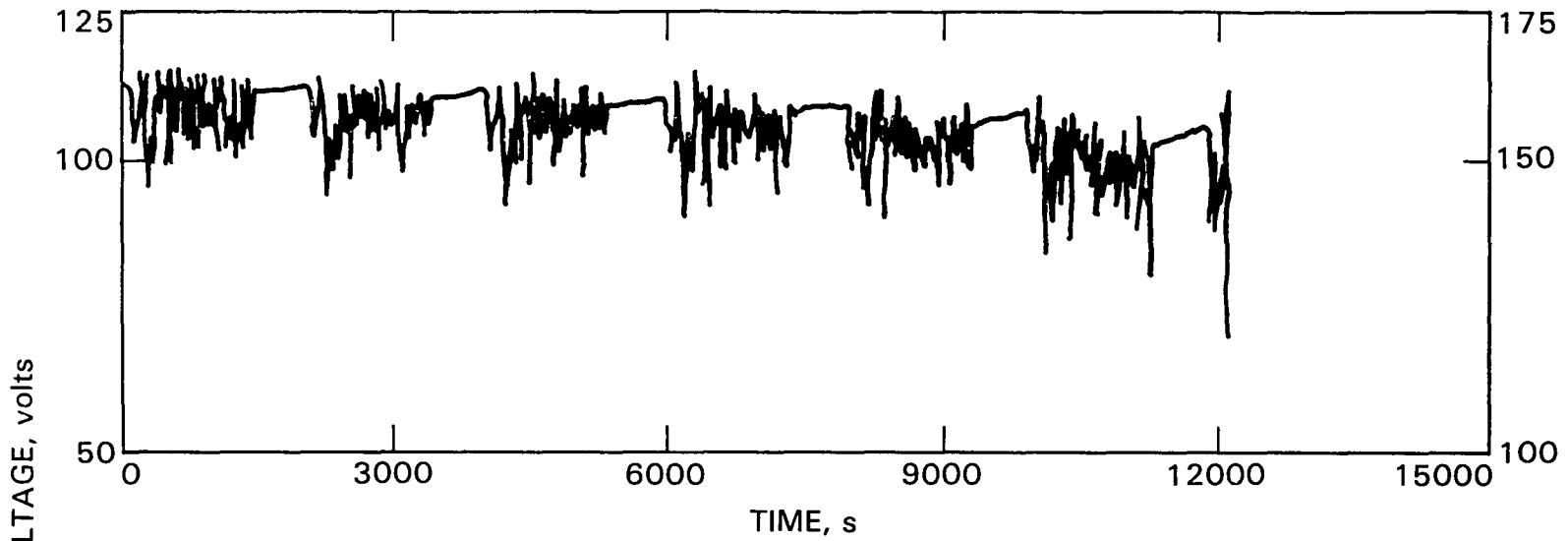

Figure B-2b.

B-4

FTP  
DYNAMOMETER TEST



TRACK TEST

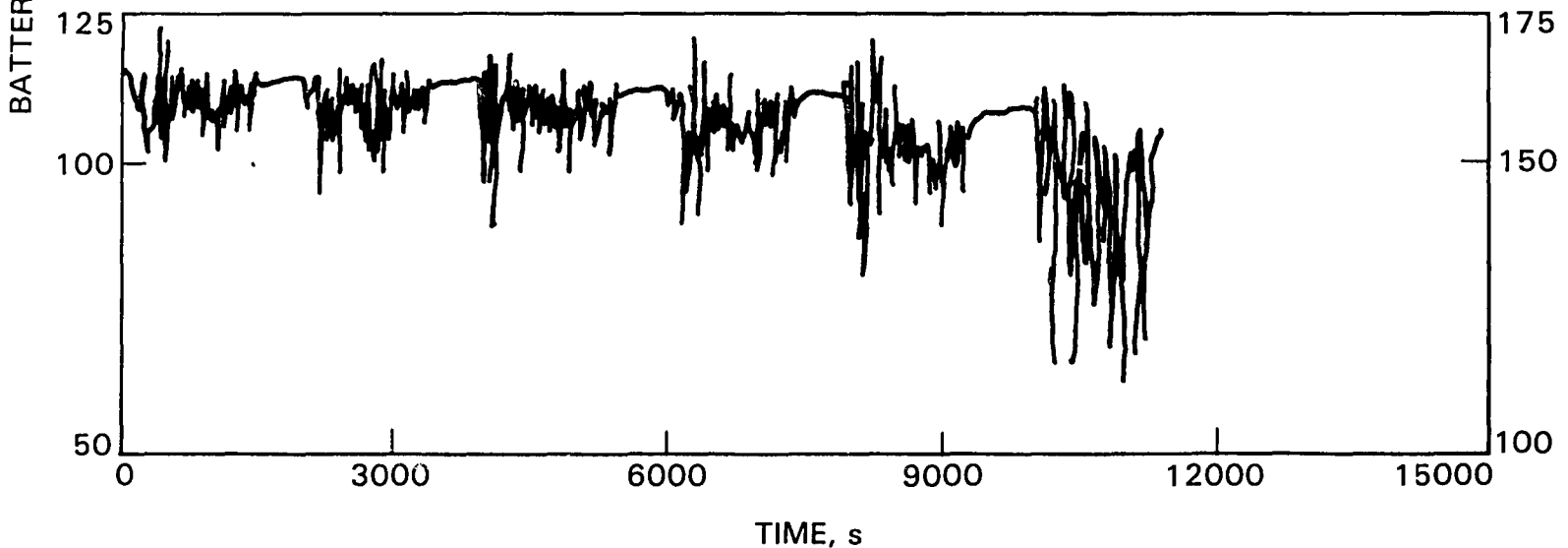

Figure B-2c.

B-5

### FTP DYNAMOMETER TEST

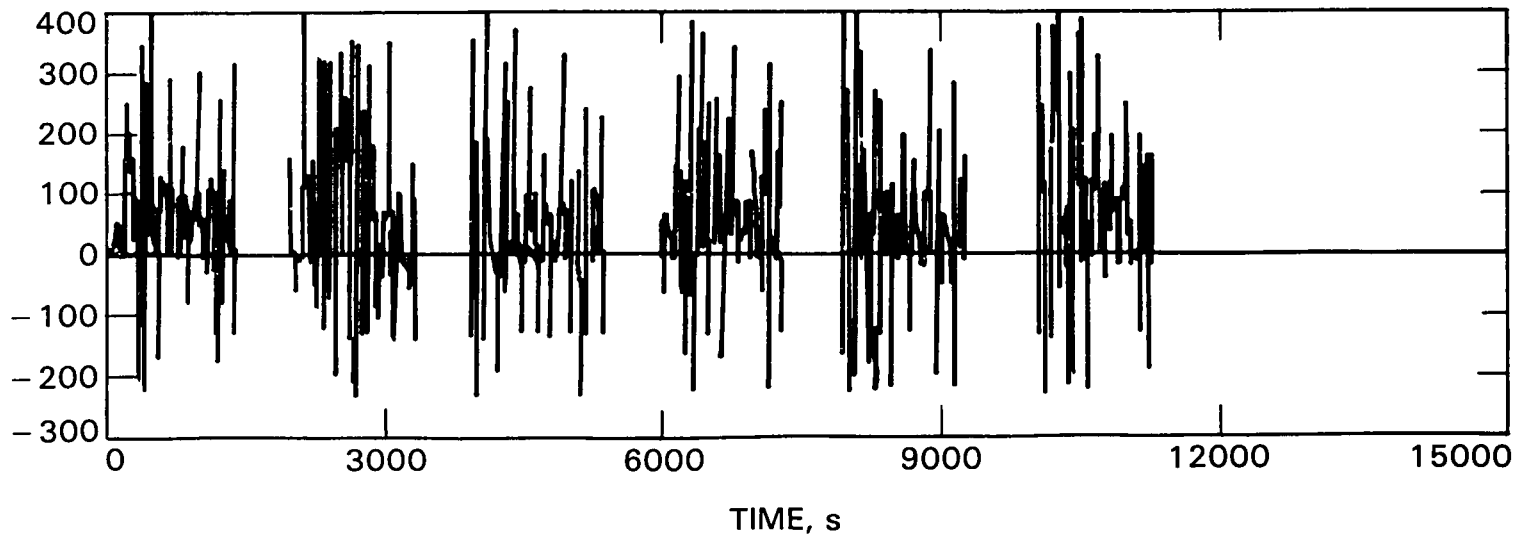
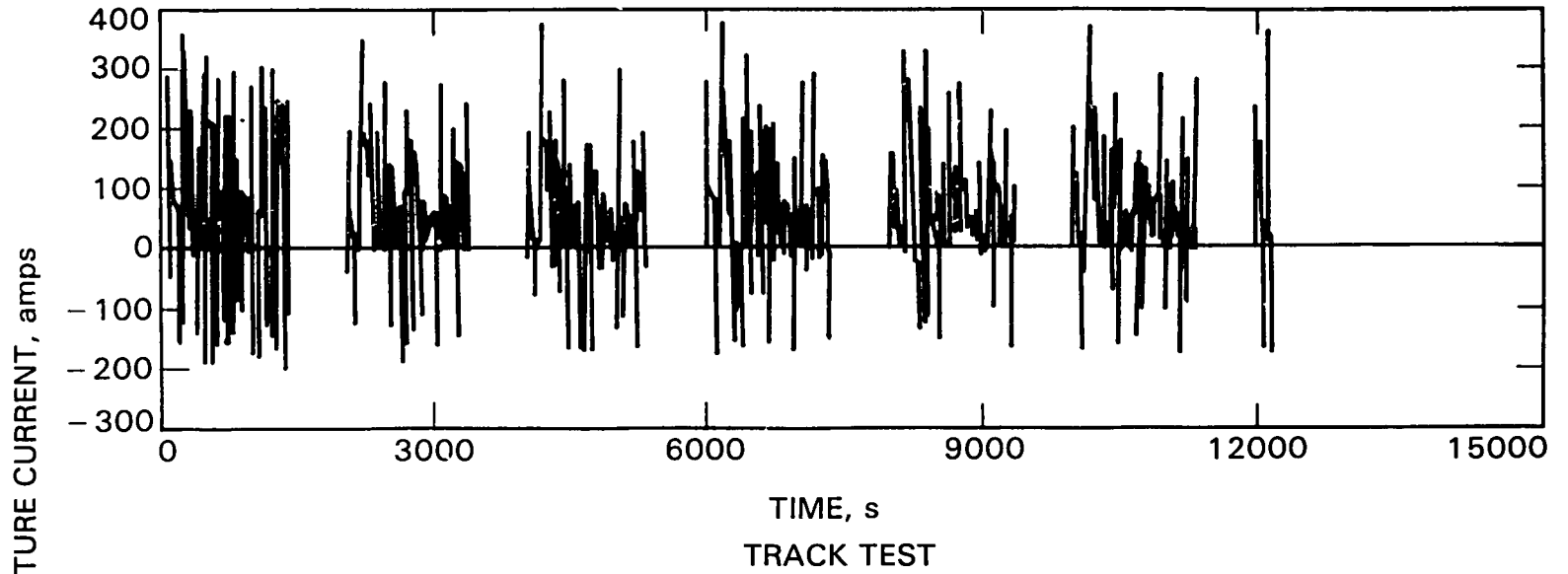
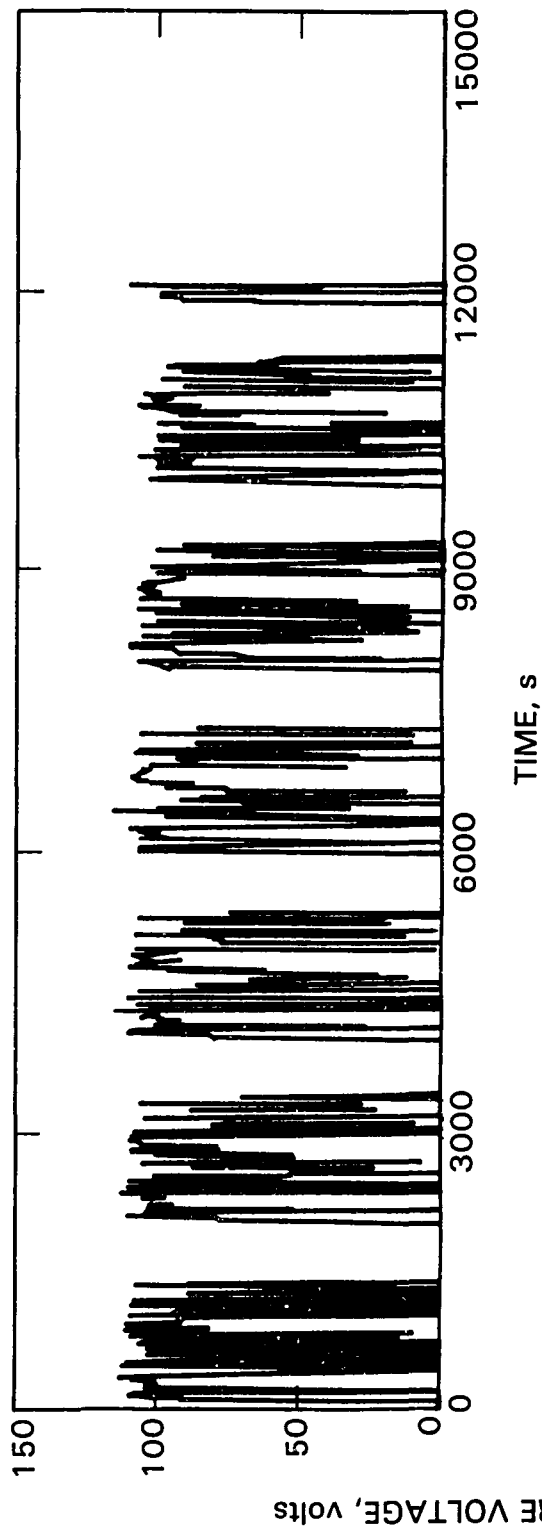

Figure B-2d.

FTP  
DYNAMOMETER TEST



TRACK TEST

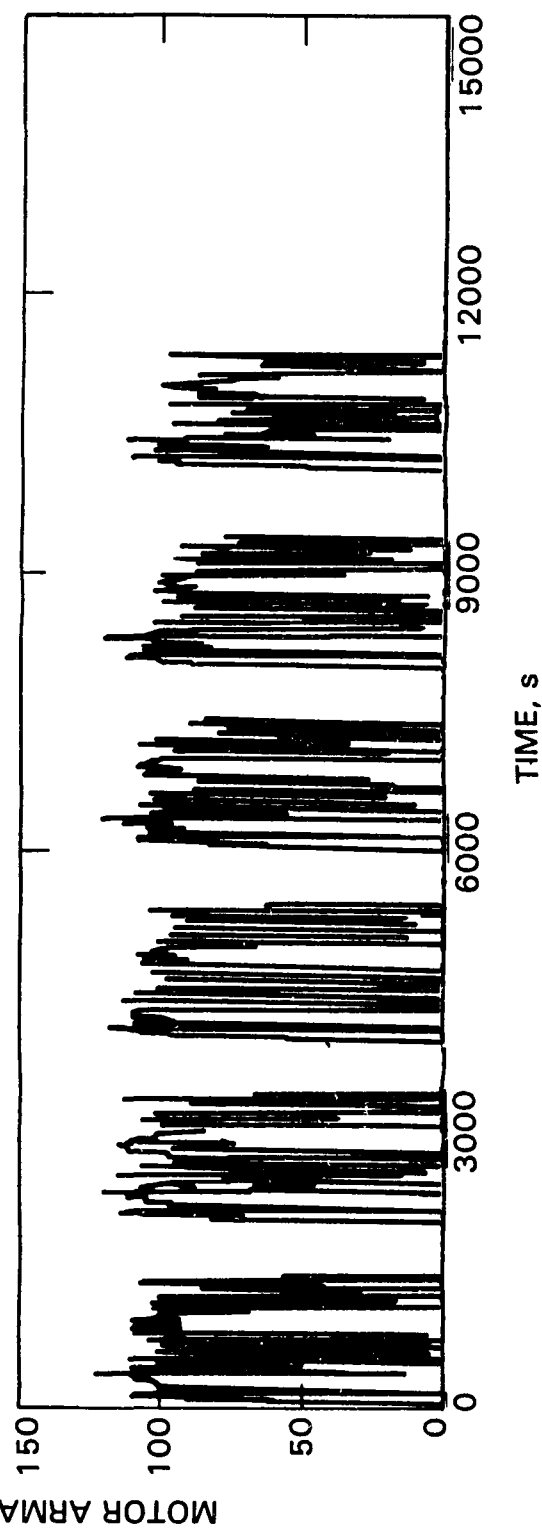

Figure B-2e.

FTP

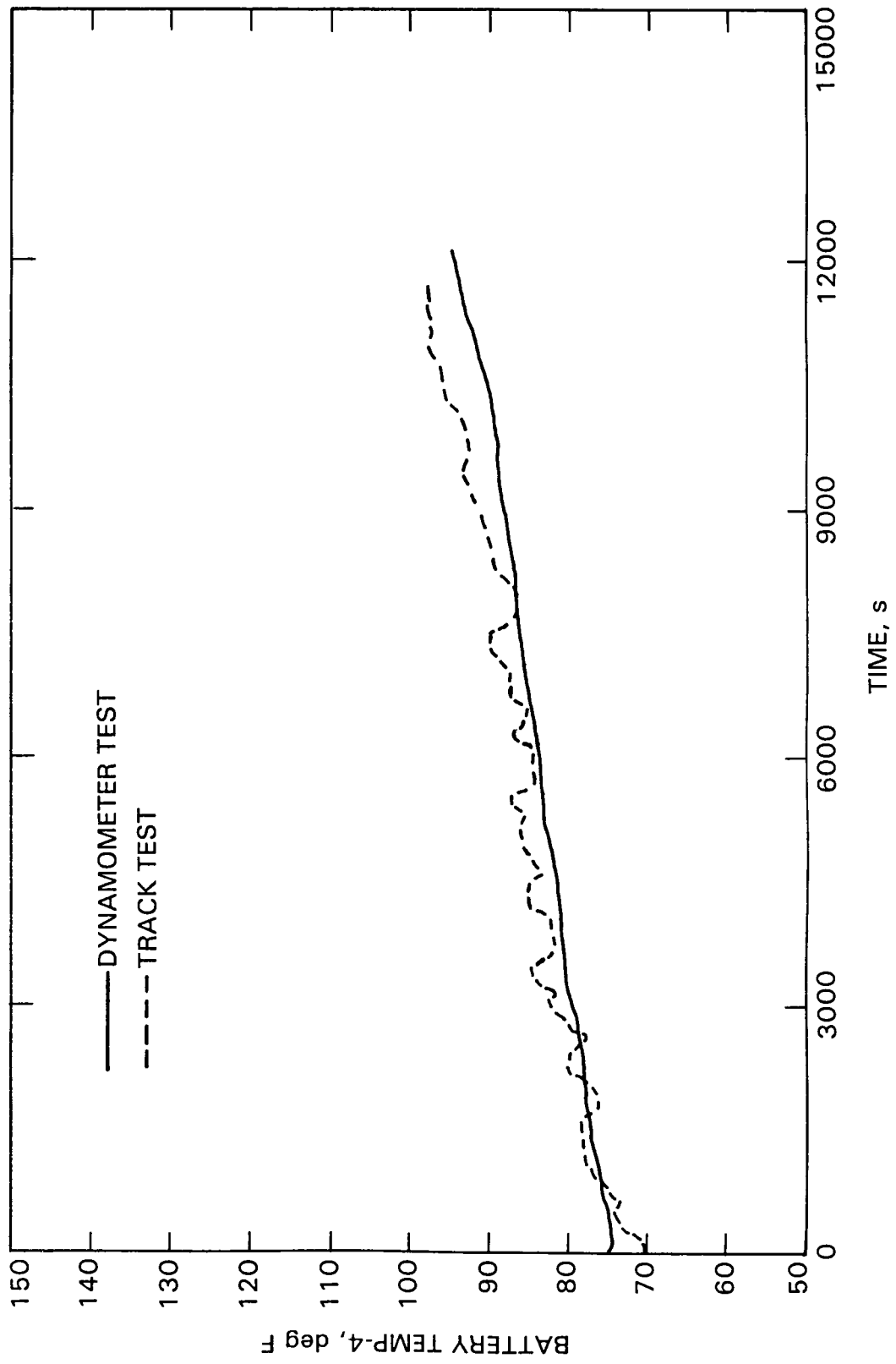

Figure B-2f.

FTP

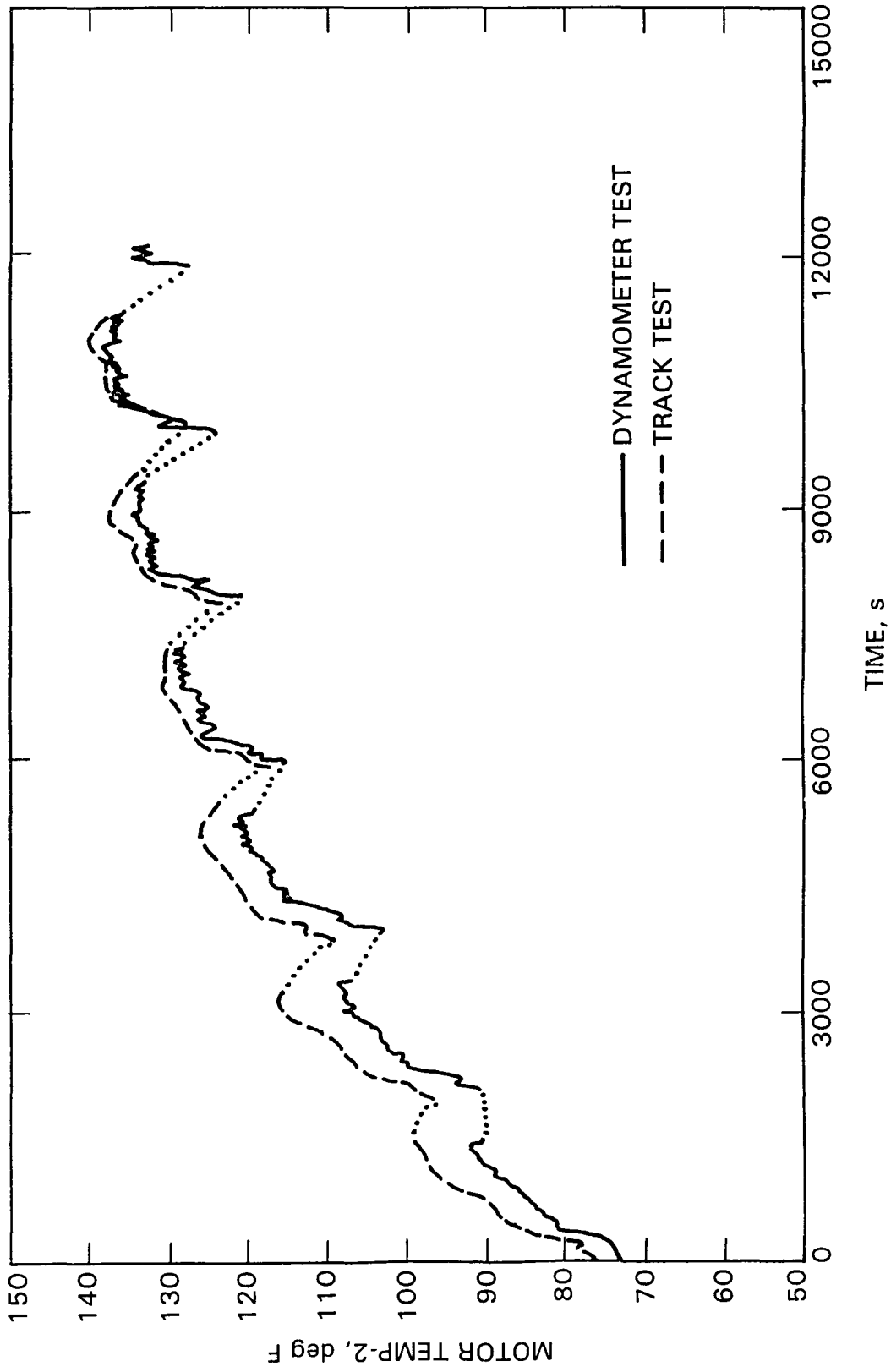
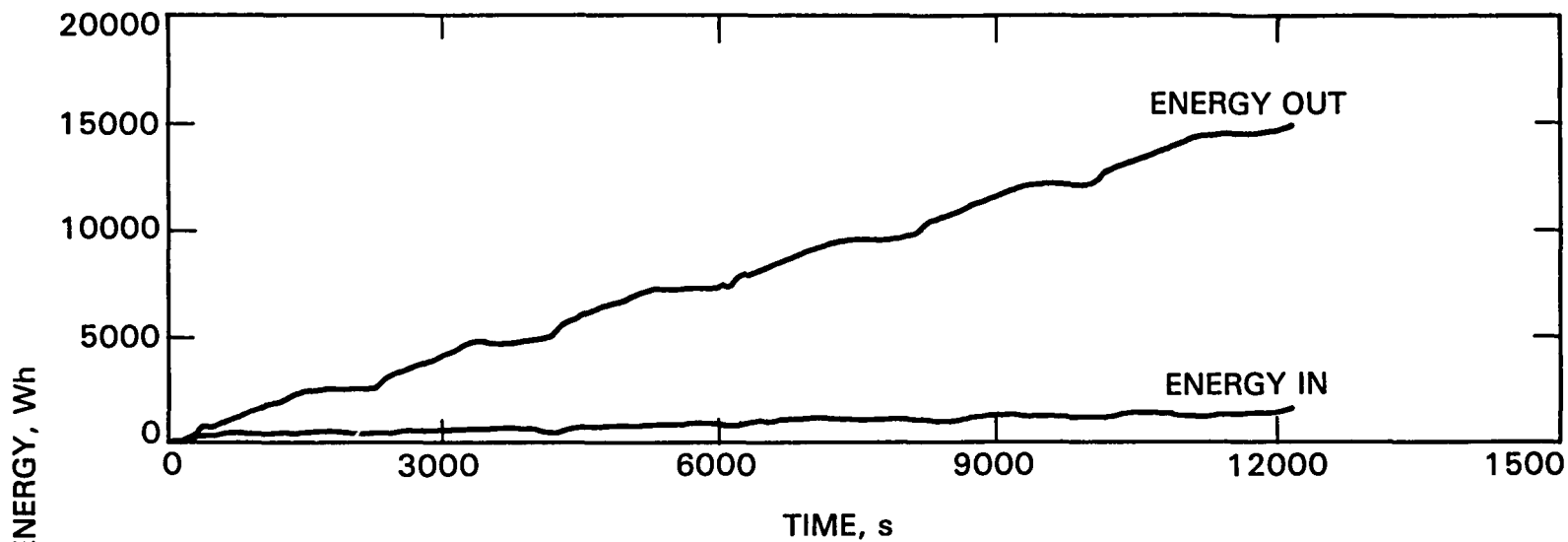

Figure B-2g.

FTP  
DYNAMOMETER TEST



B-10

TRACK TEST

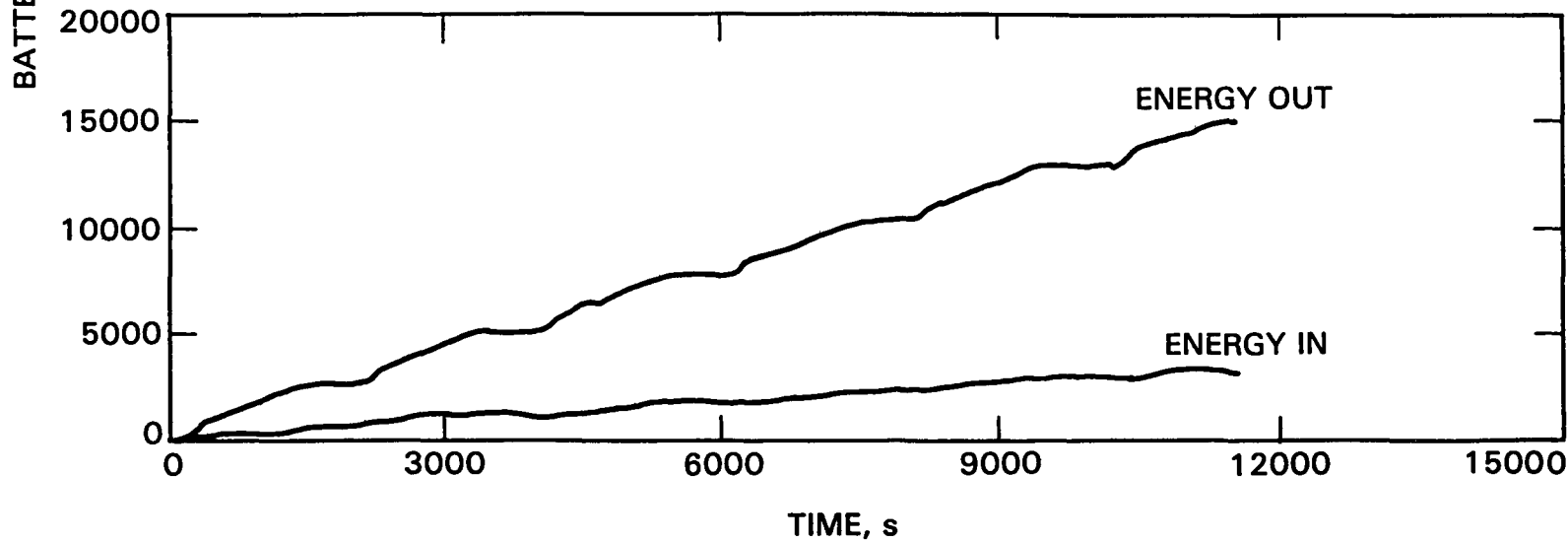

Figure B-2h.



35 mi/h

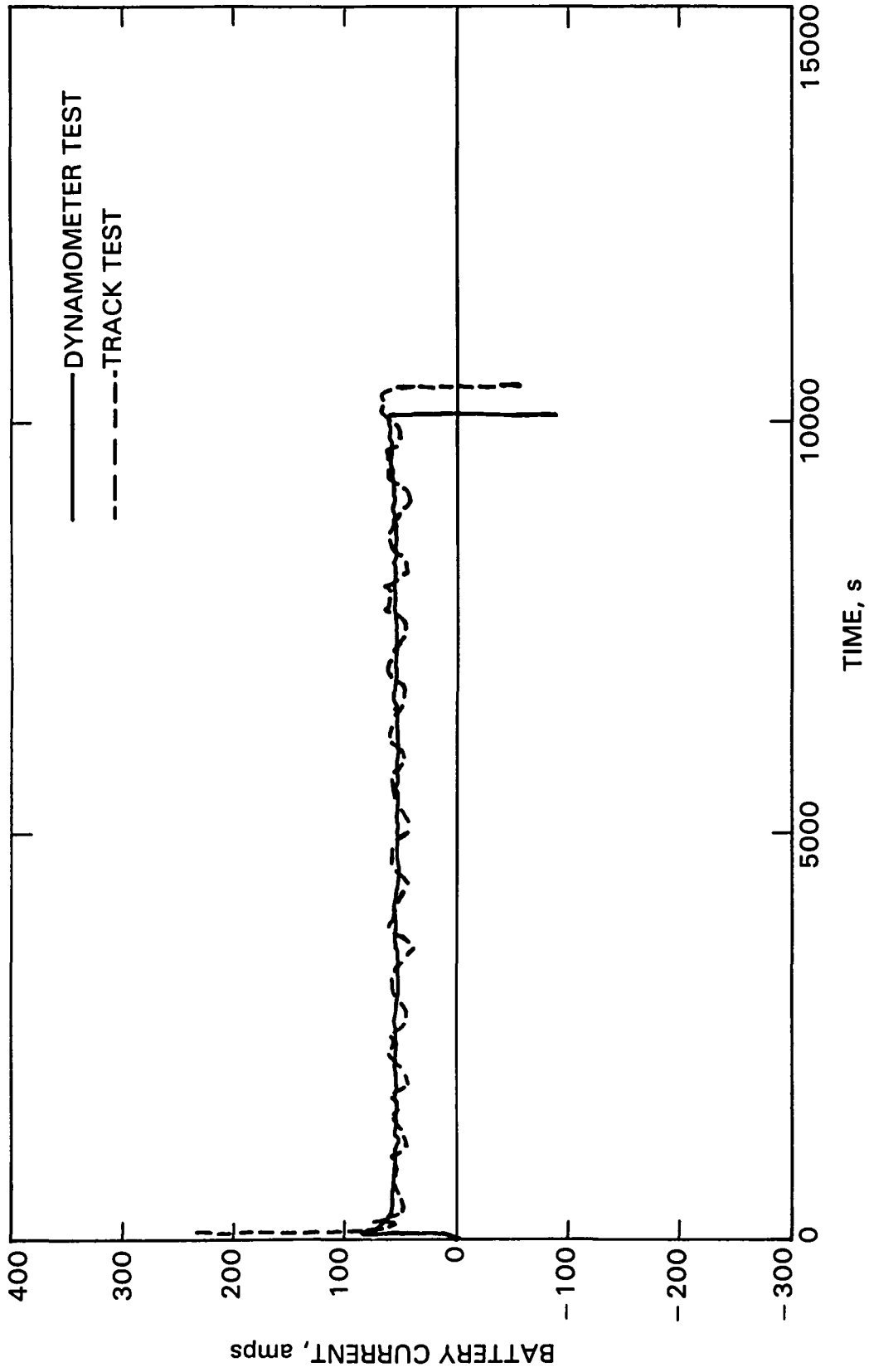

Figure B-3.

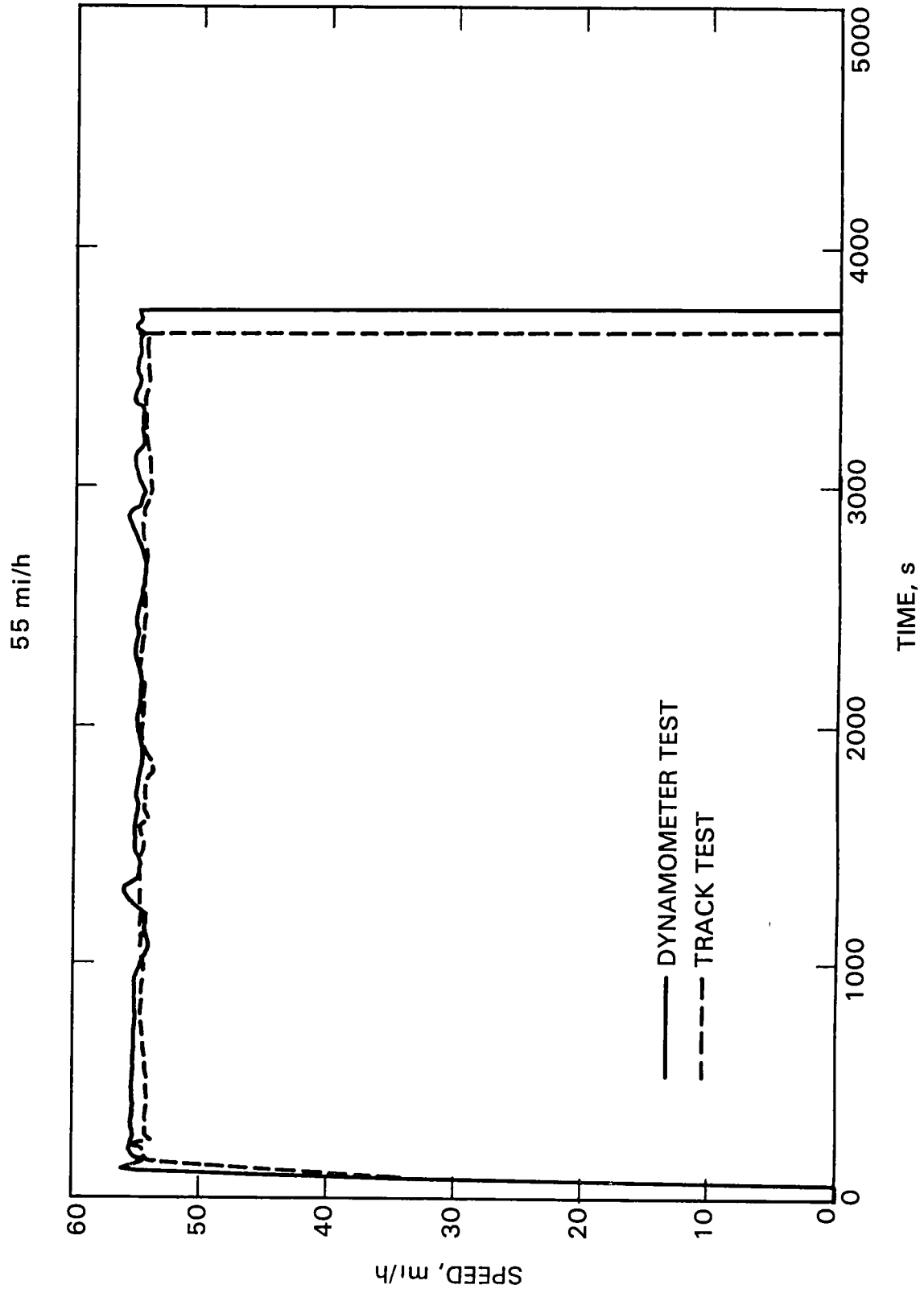
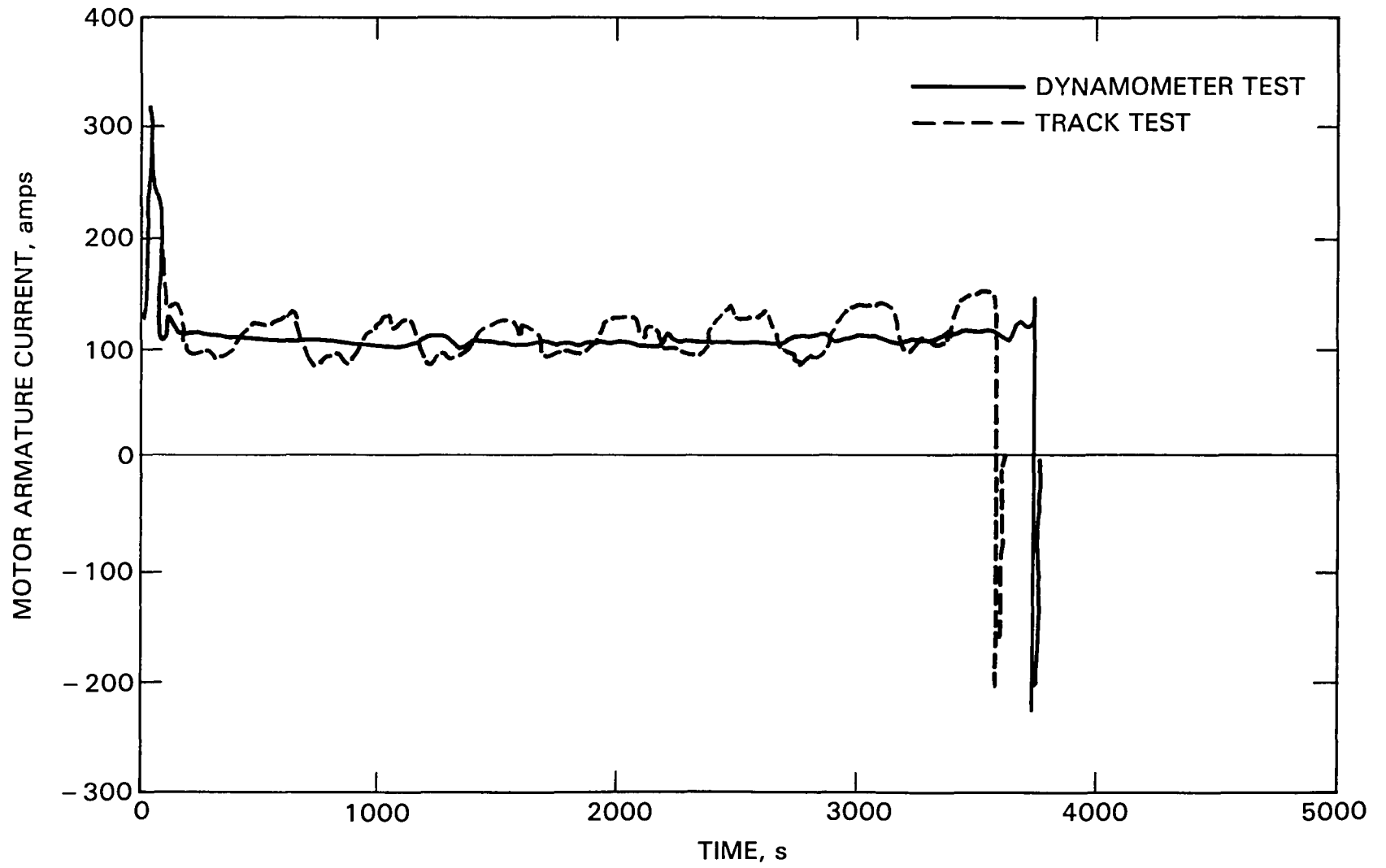

Figure B-3a.

55 mi/h



B-13

Figure B-3b.

55 mi/h

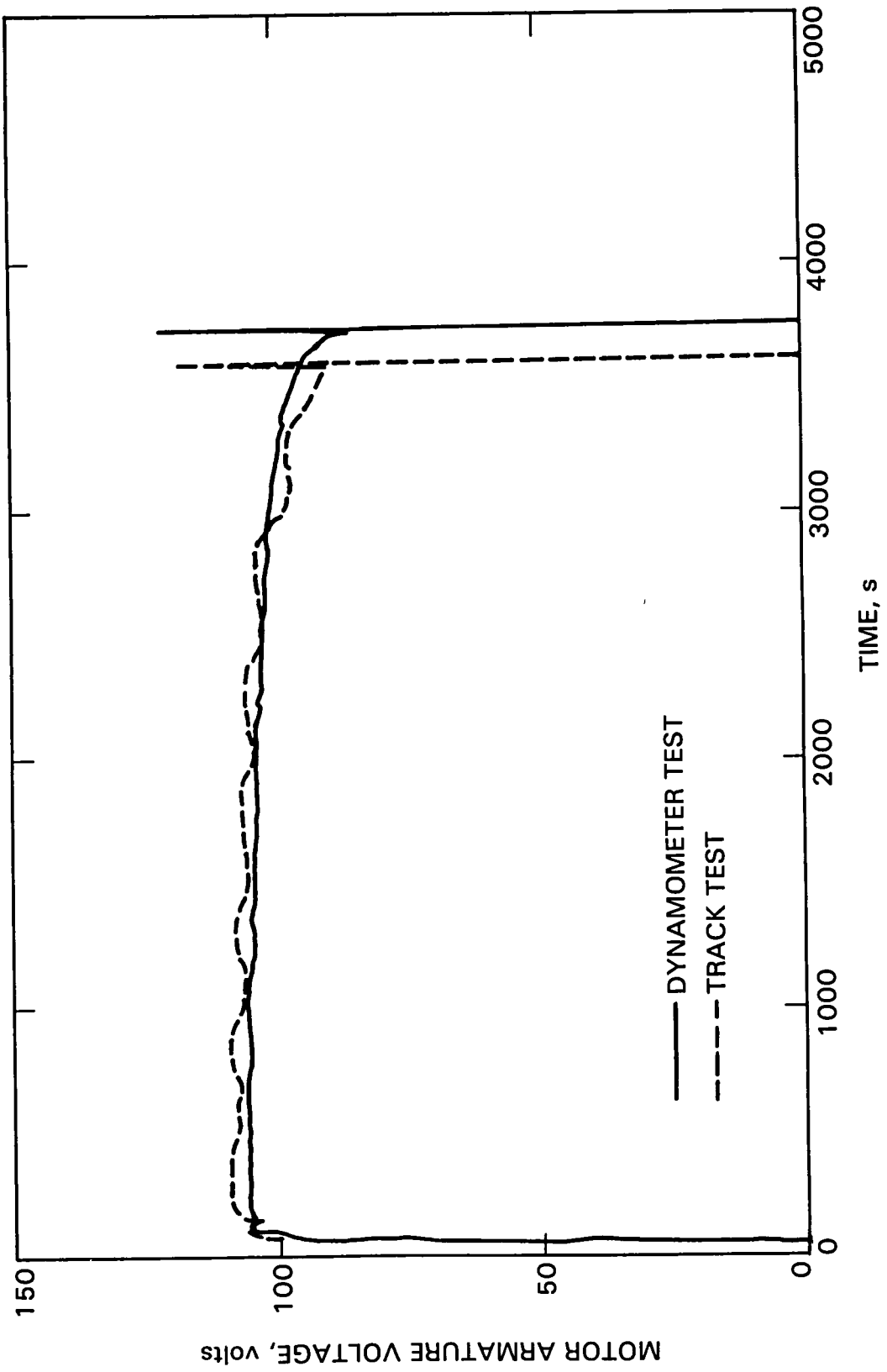

Figure B-3c.

55 mi/h

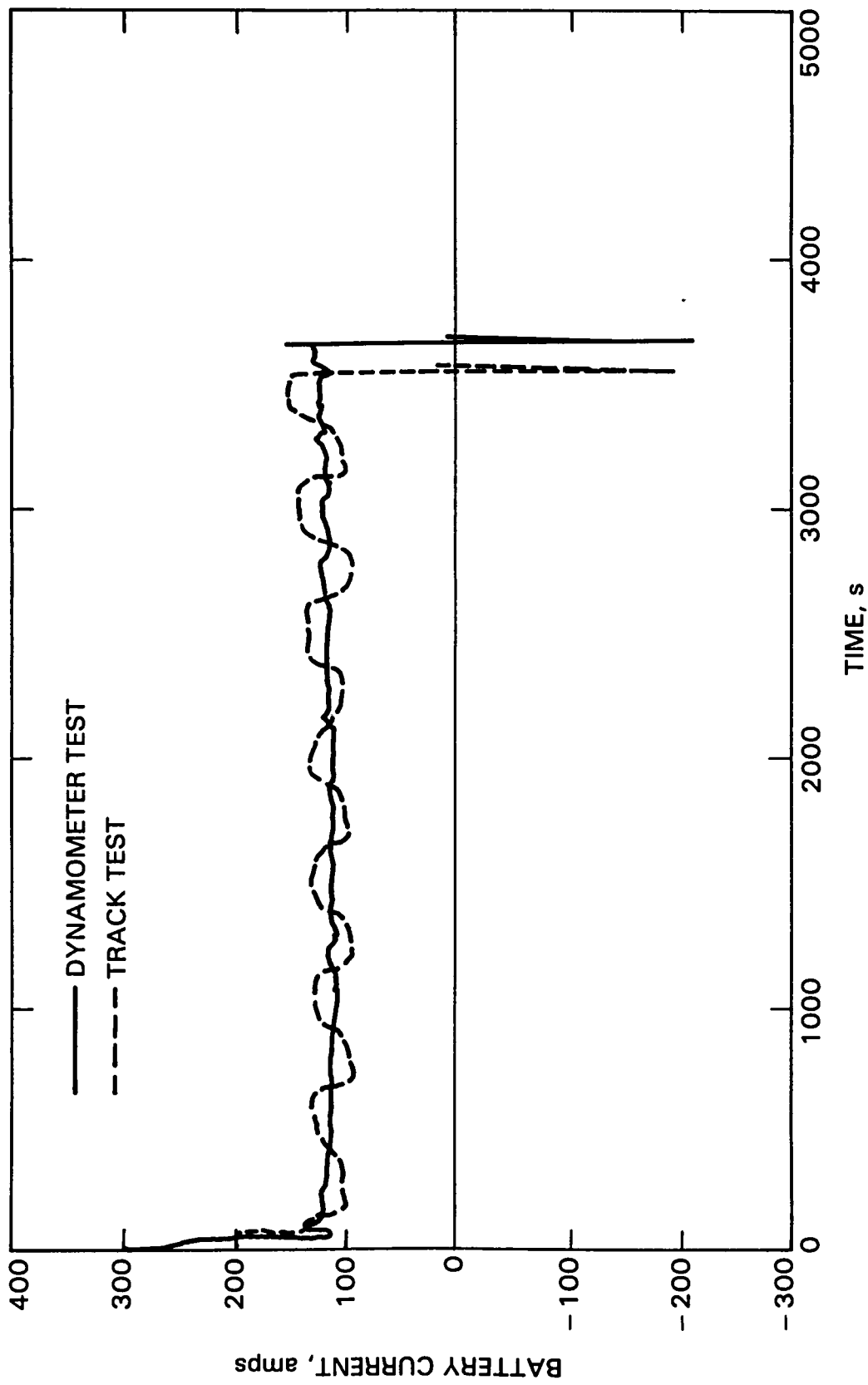

Figure B-3d.

55 mi/h

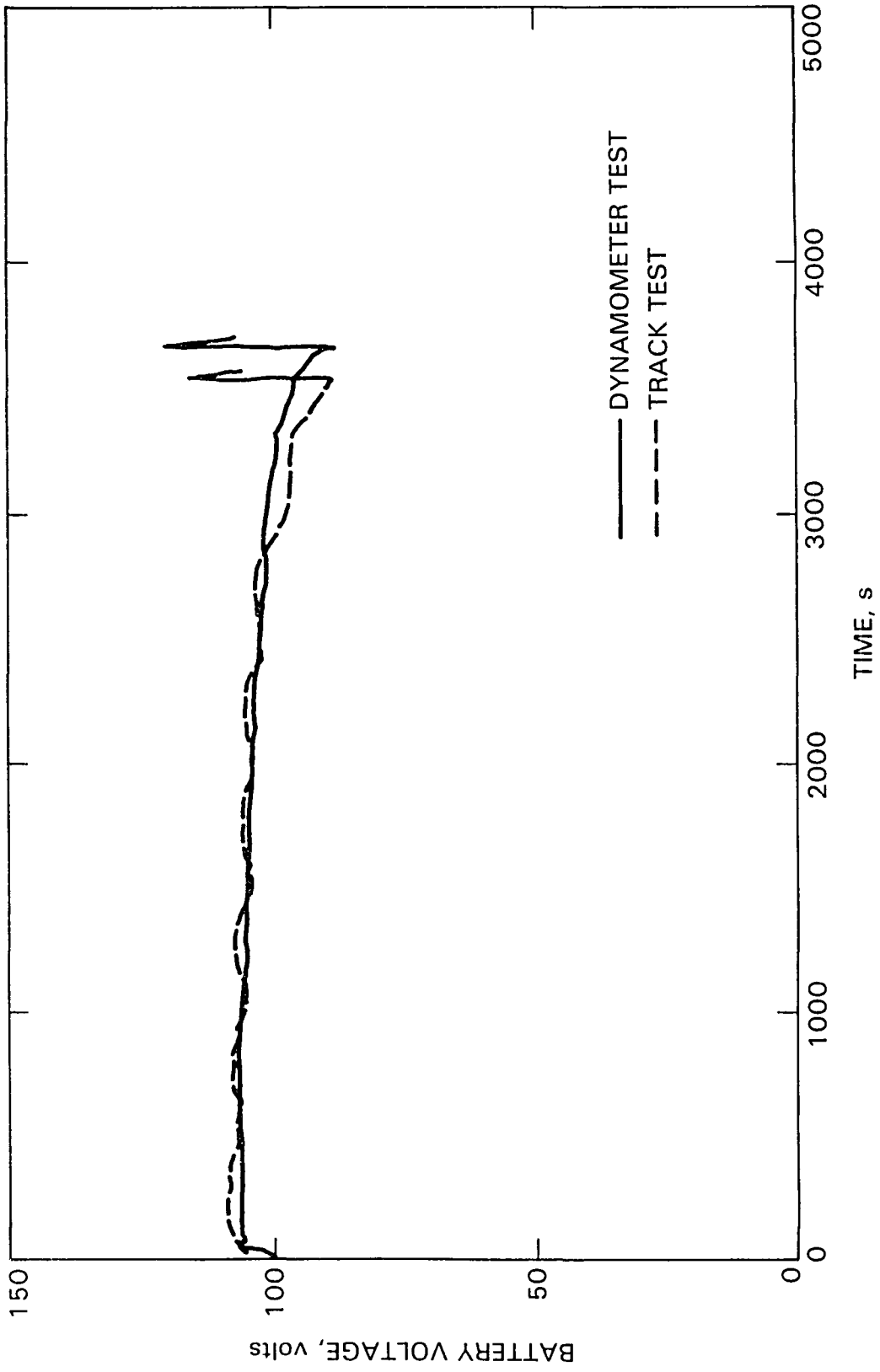

Figure B-3e.

55 mi/h

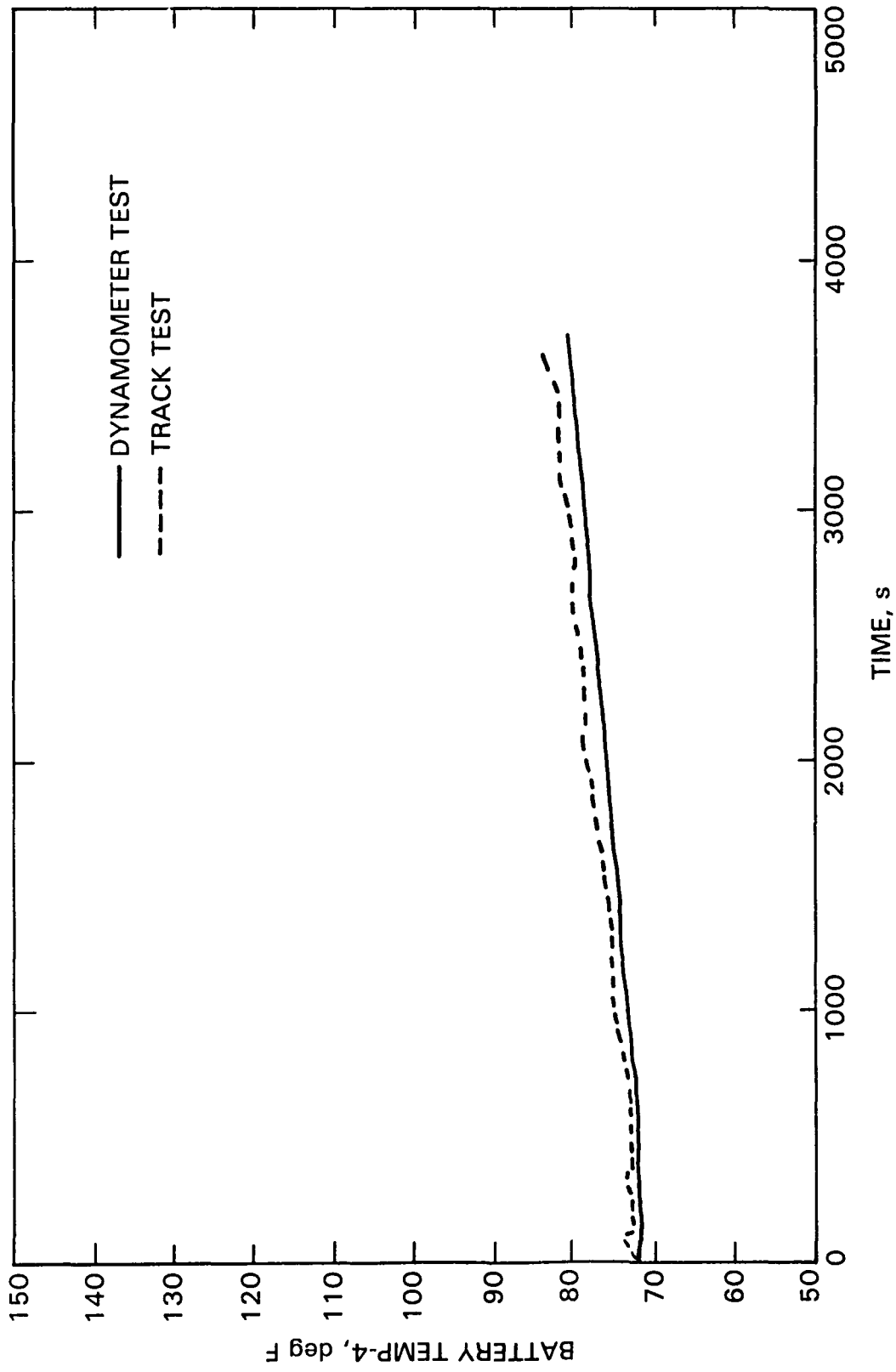

Figure B-3f.

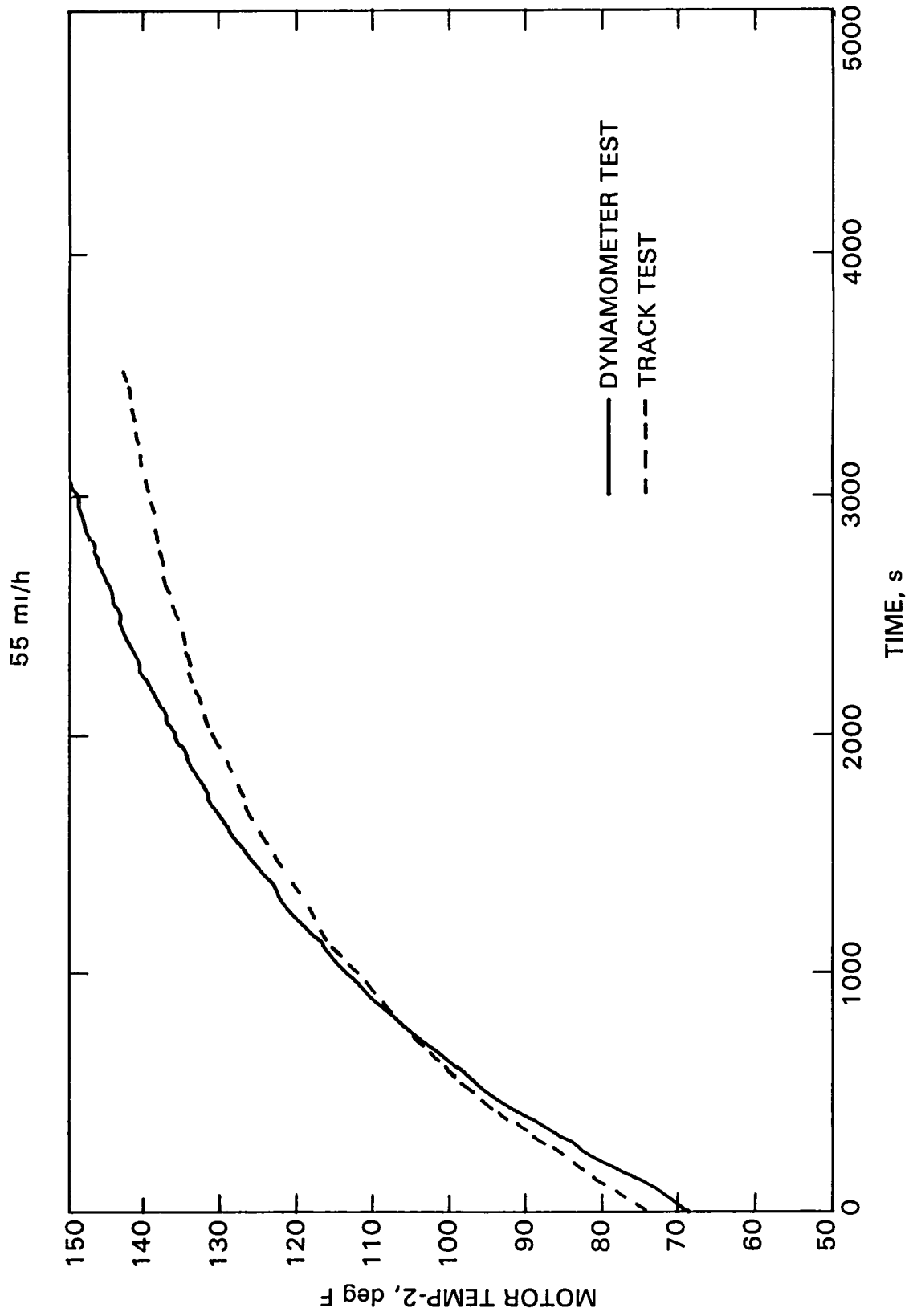
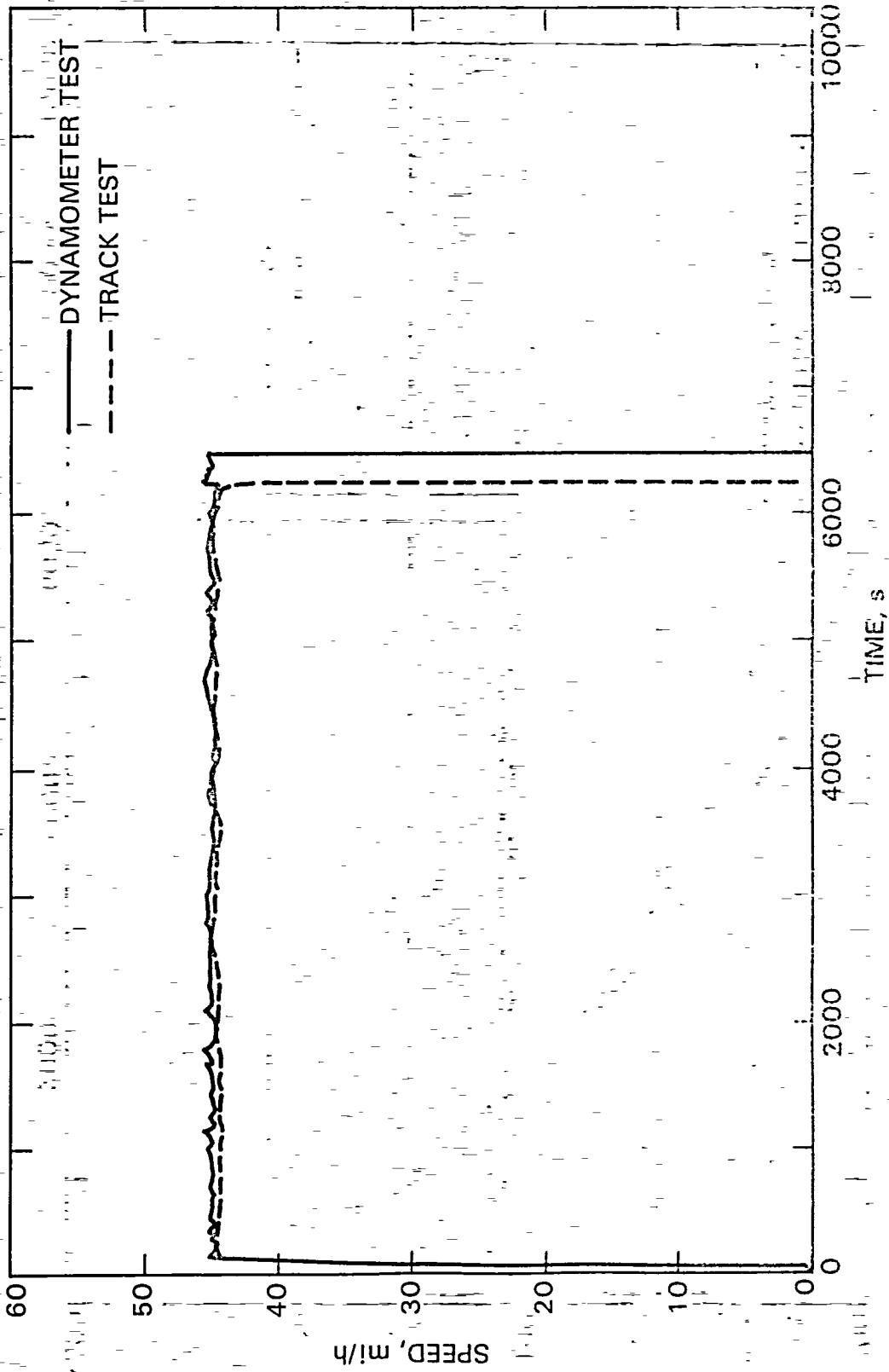

Figure B-3g.



45 mi/h



45 mi/h

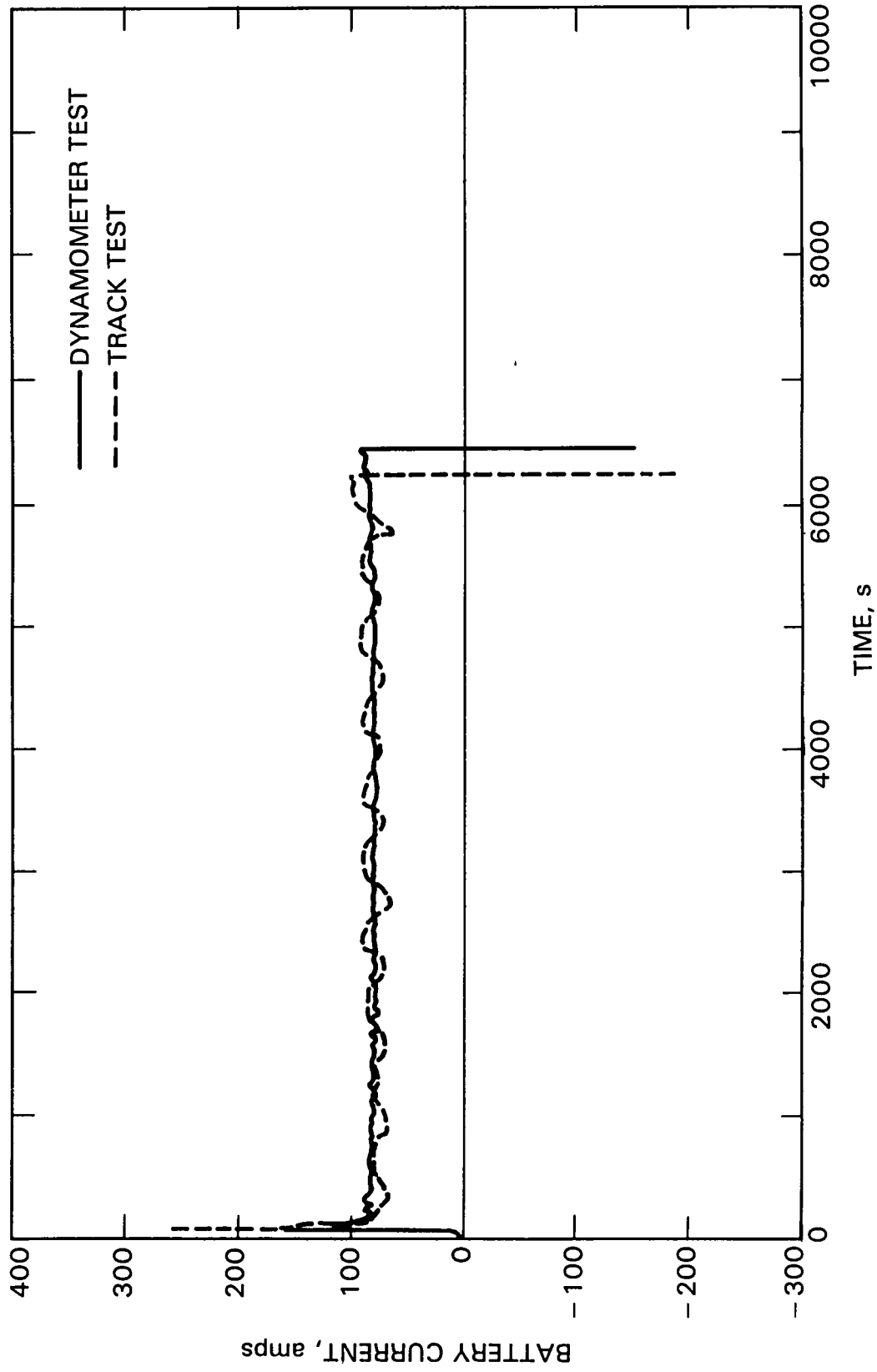

Figure B-4b.

45 mi/h

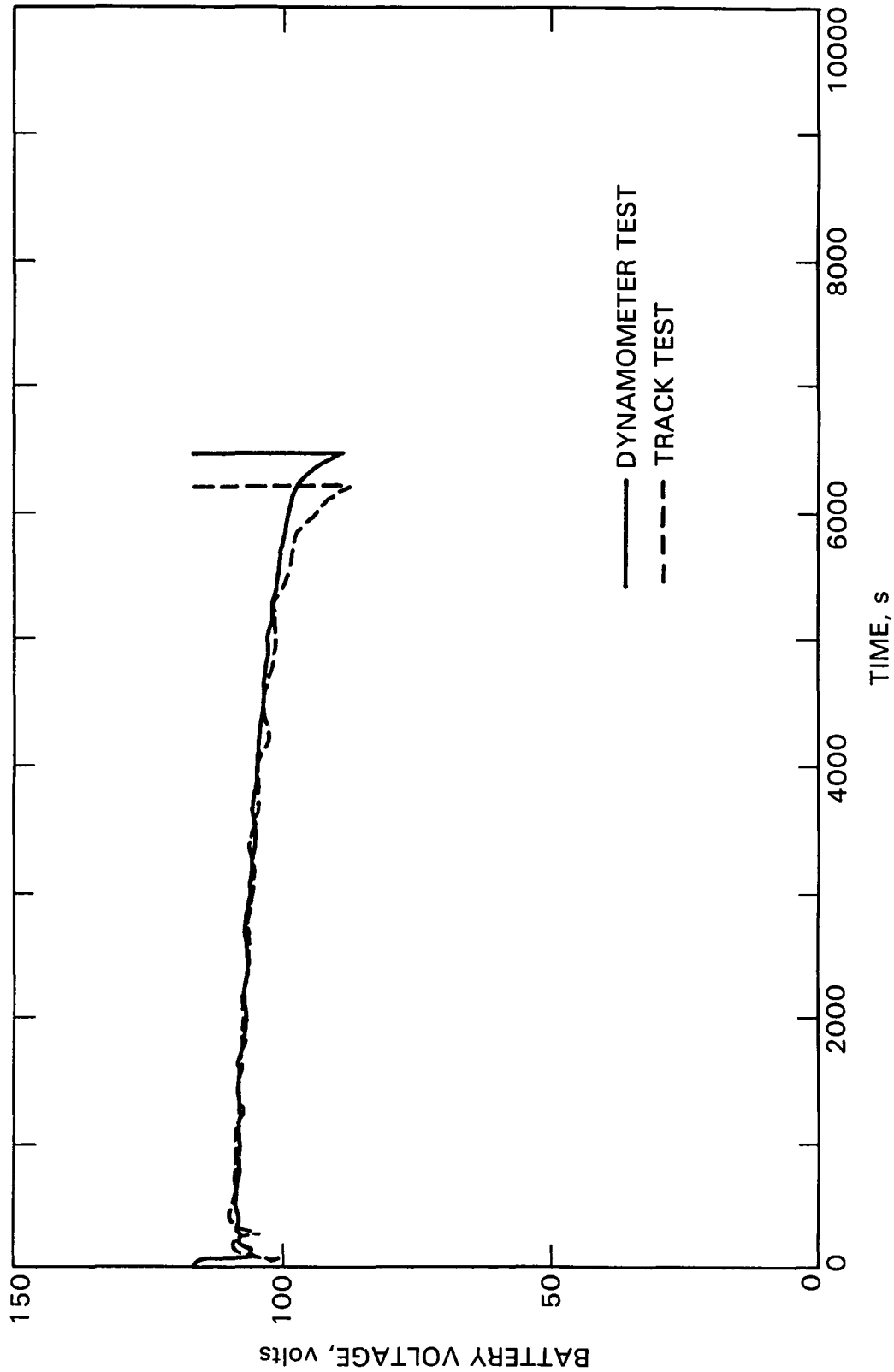

Figure B-4c.

45 r/min.

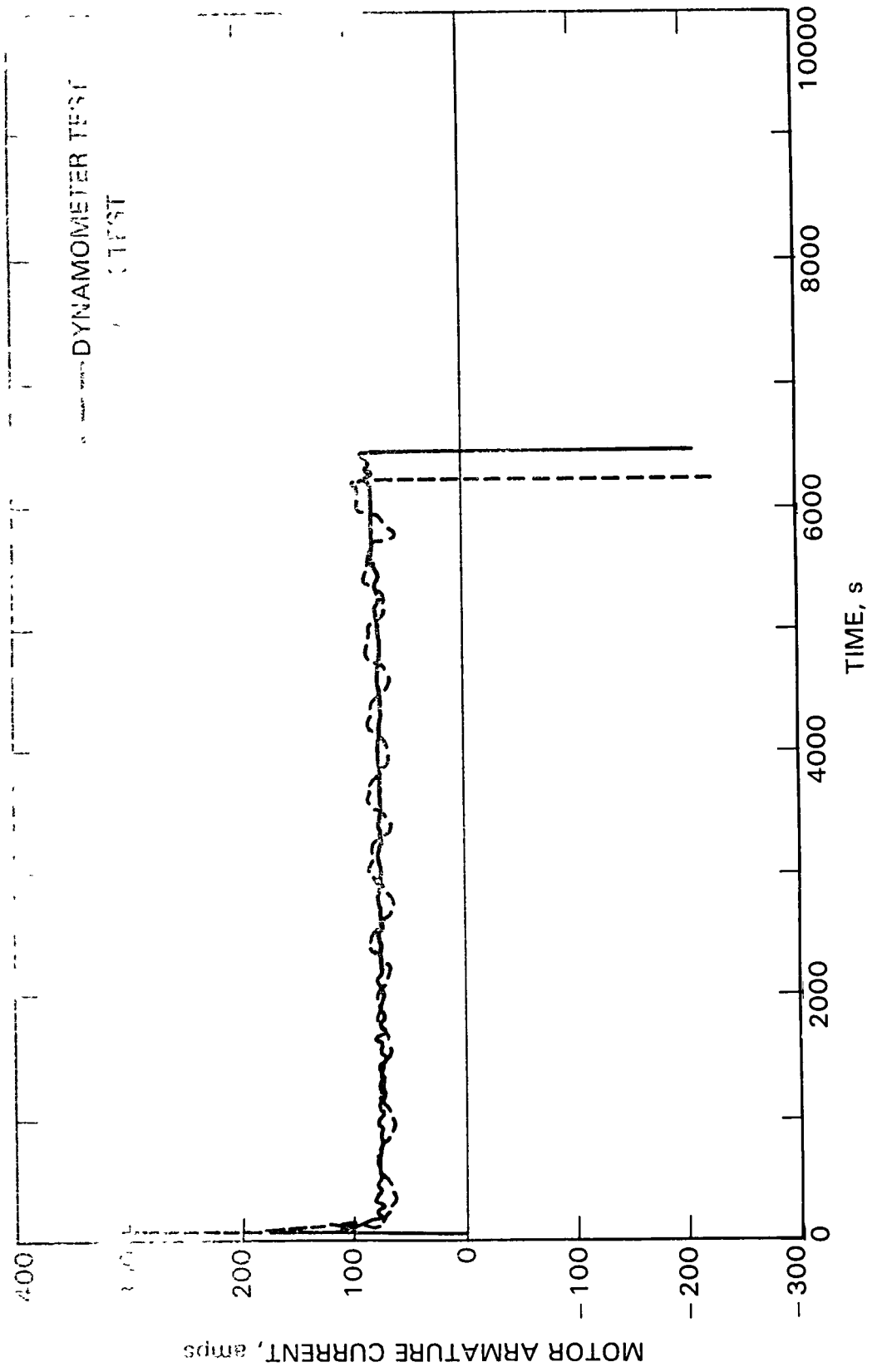

Figure B-4d.

45 mi/h

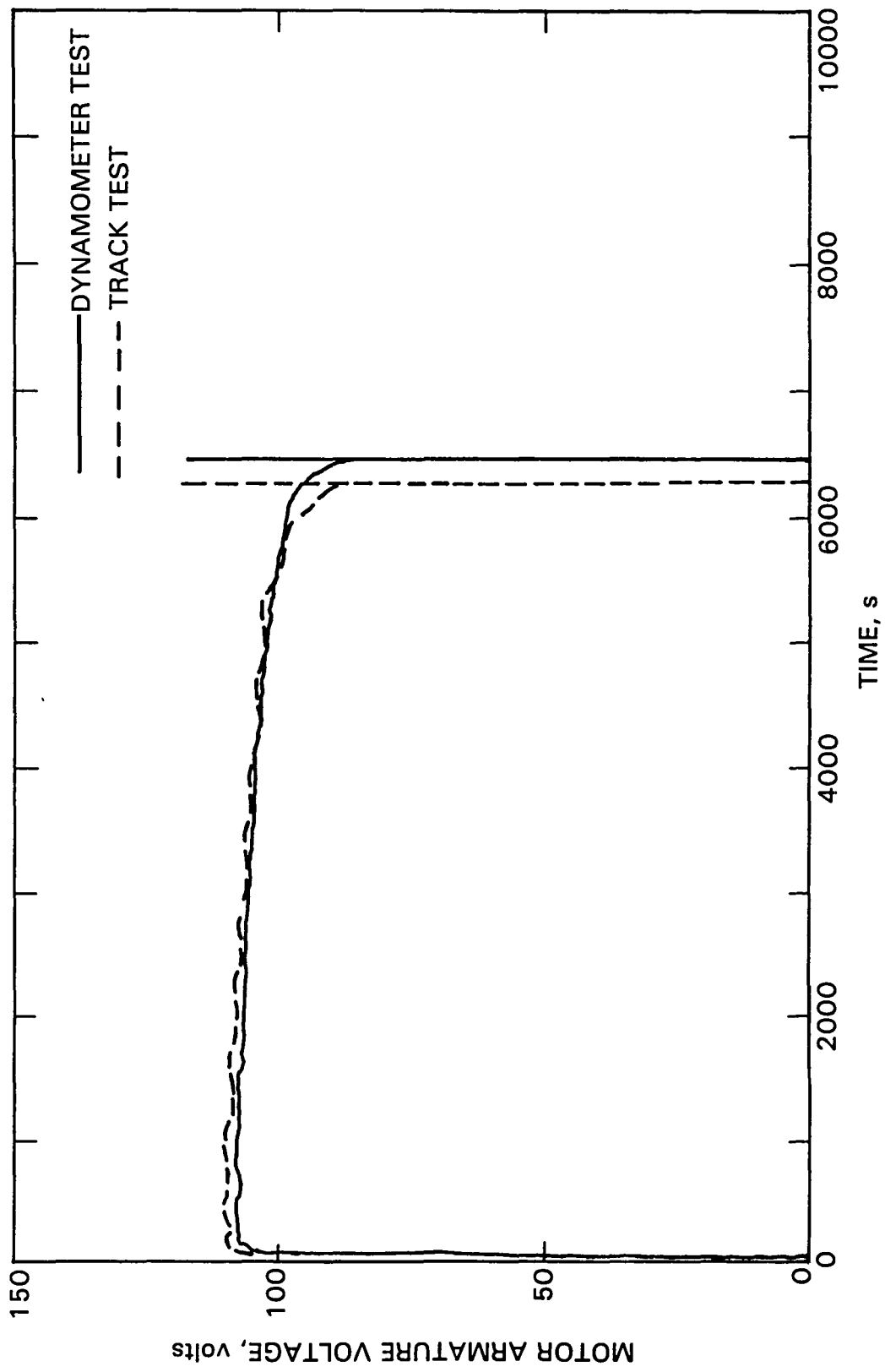

Figure B-4e.

45 mi/h

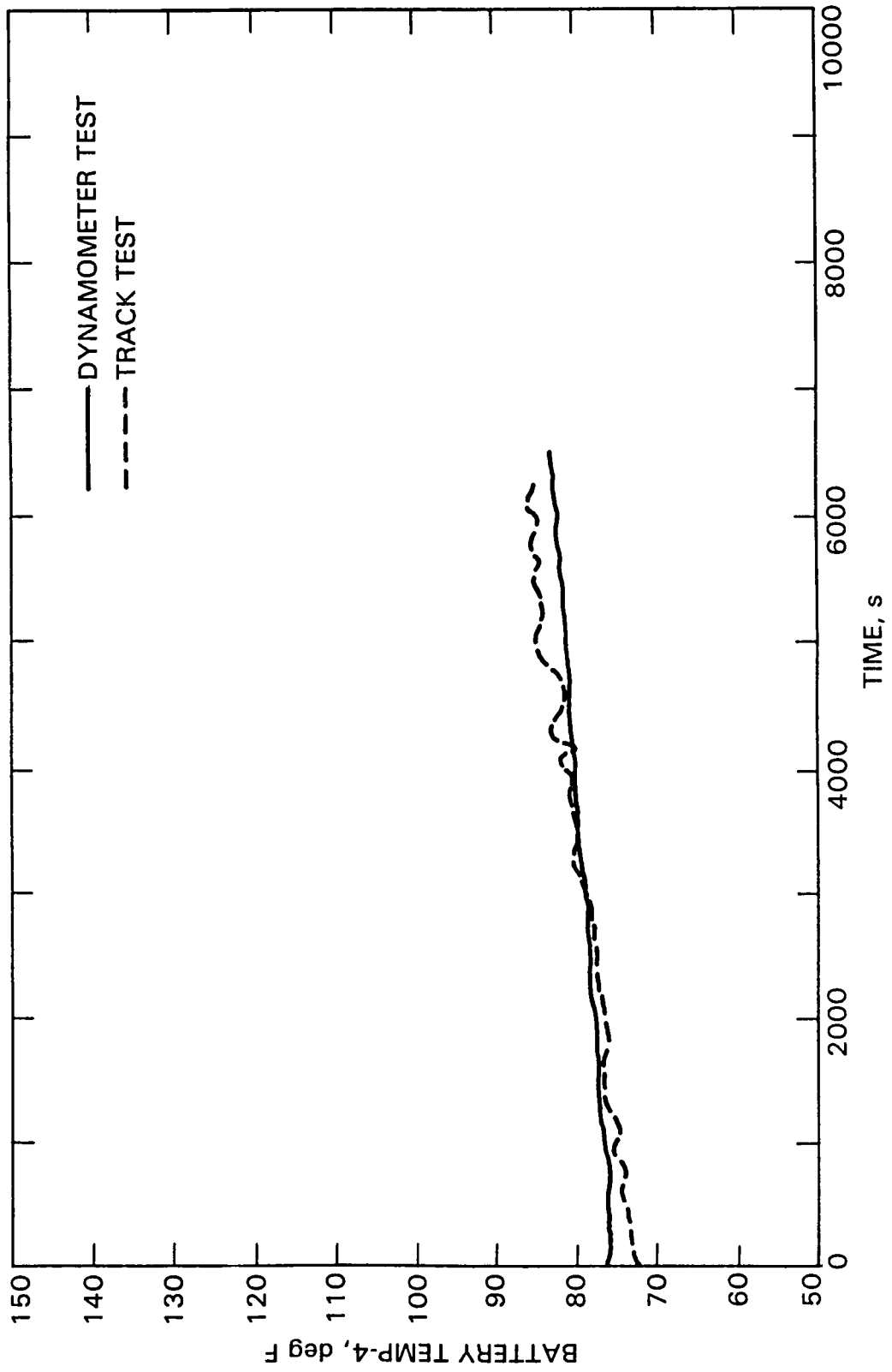

Figure B-4f.

45 mi/h

B-25

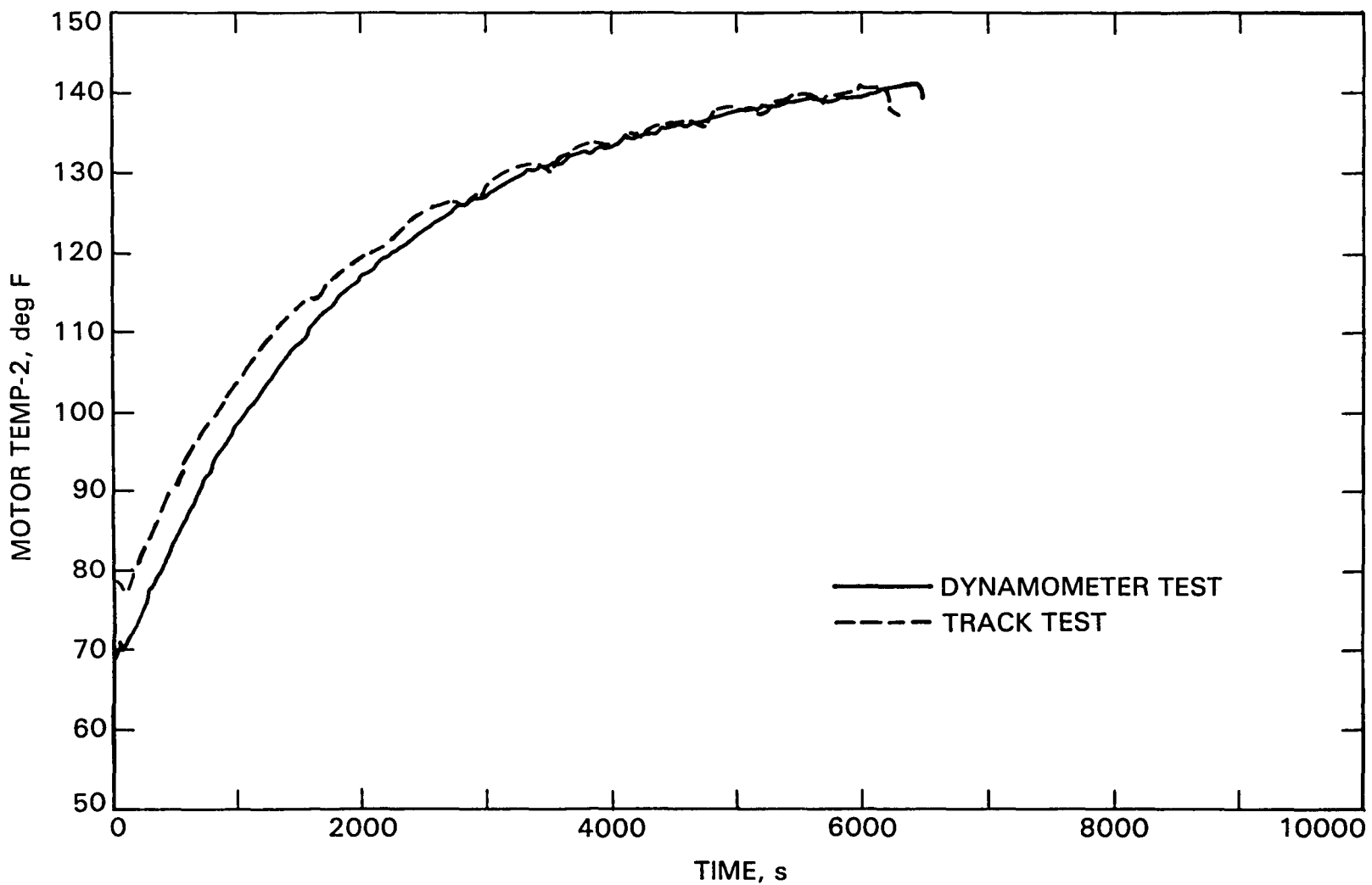

Figure B-4g.

35 mi/h

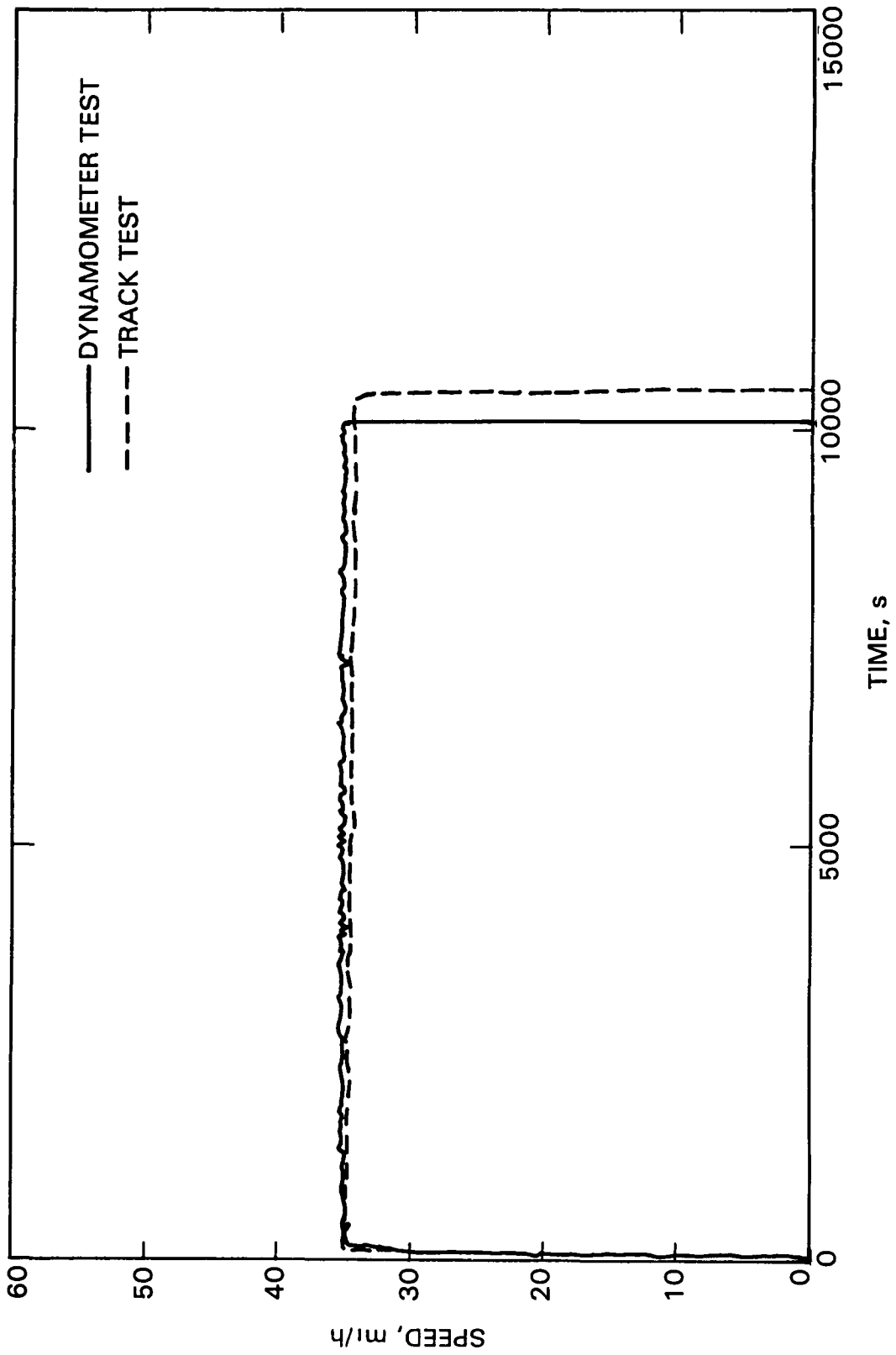

Figure B-5a.





35 mi/h

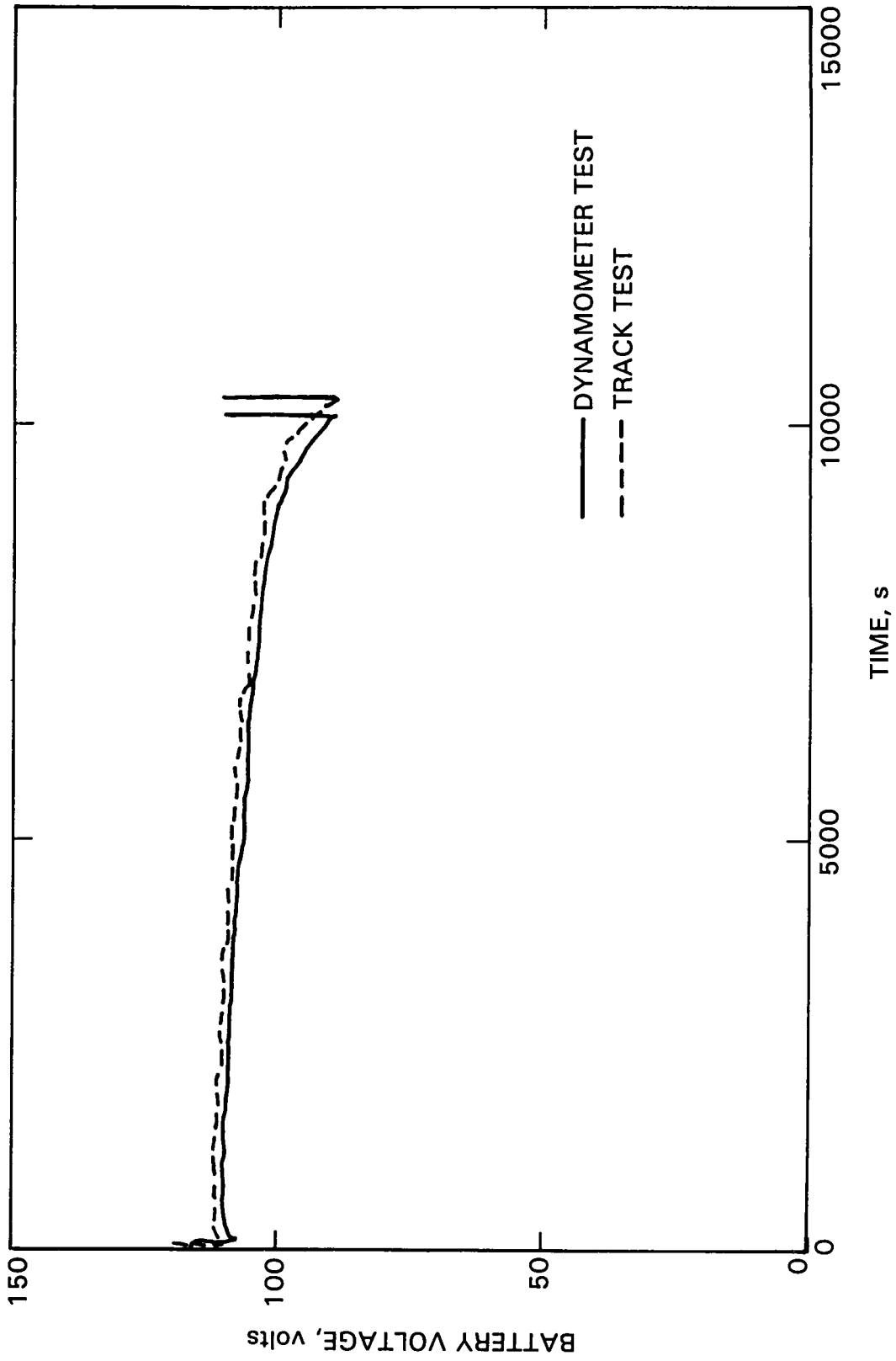

Figure B-5c.

35 mi/h

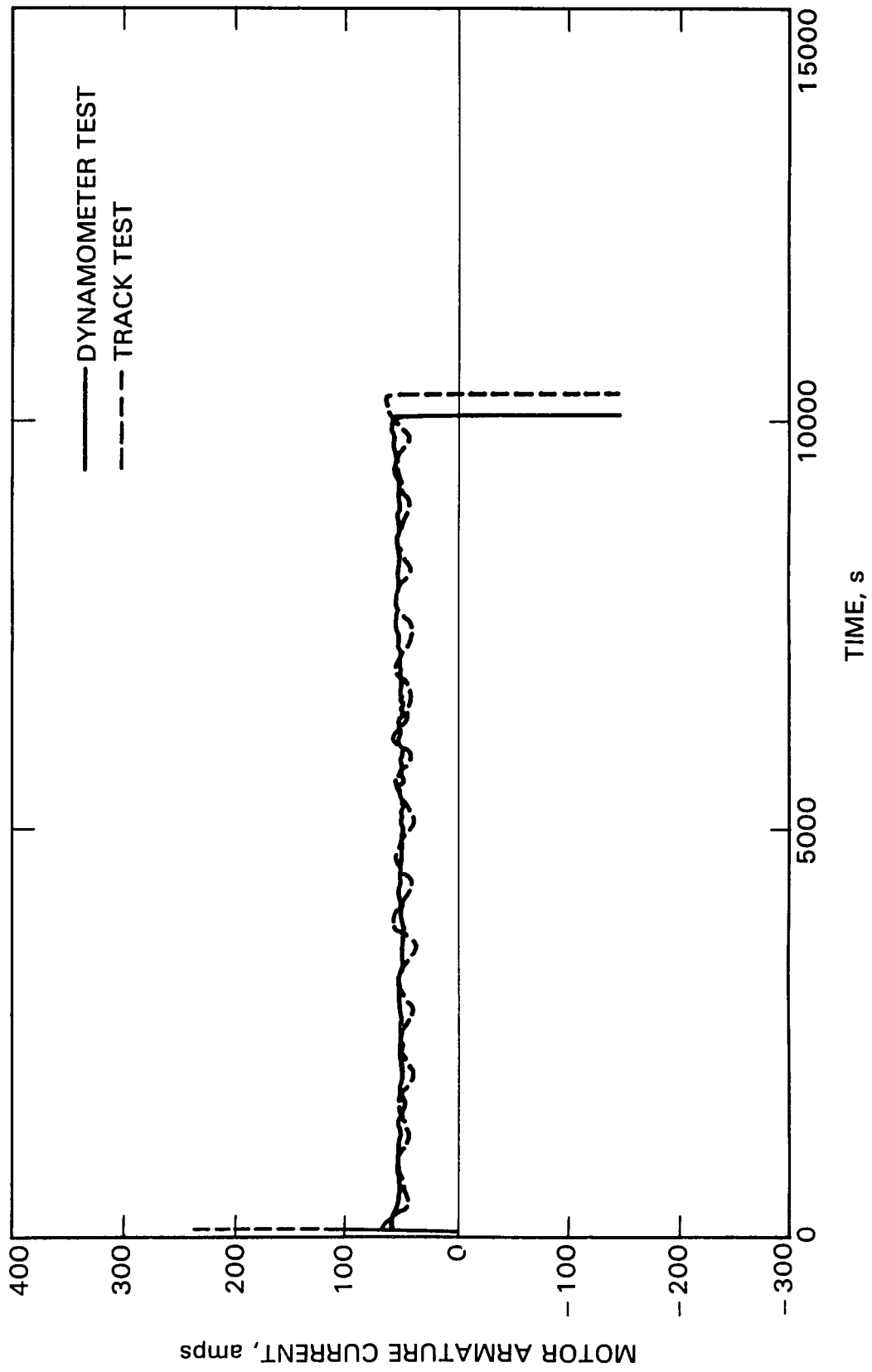

Figure B-5d.

35 mi/h

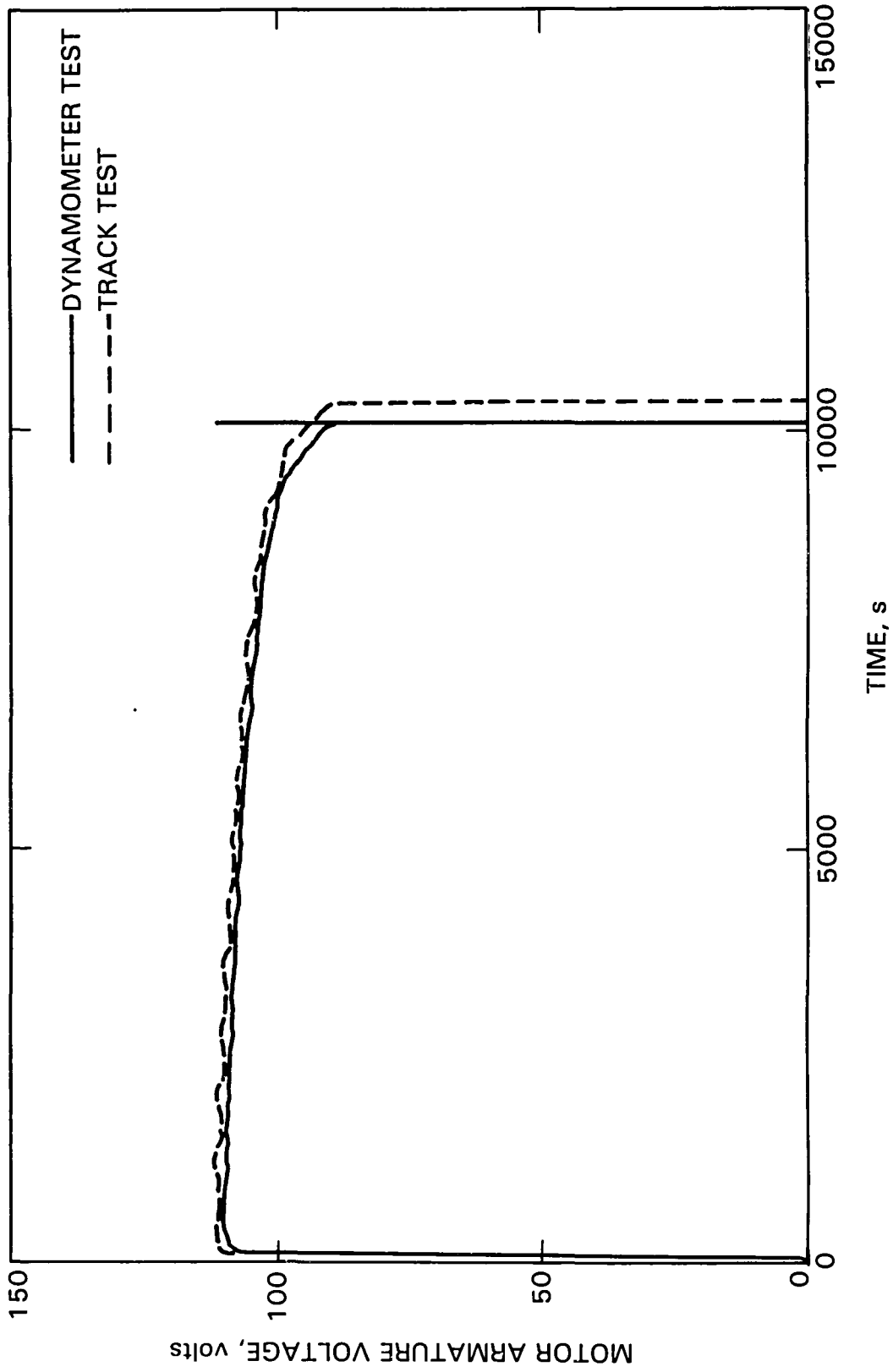

Figure B-5e.

35 mi/h

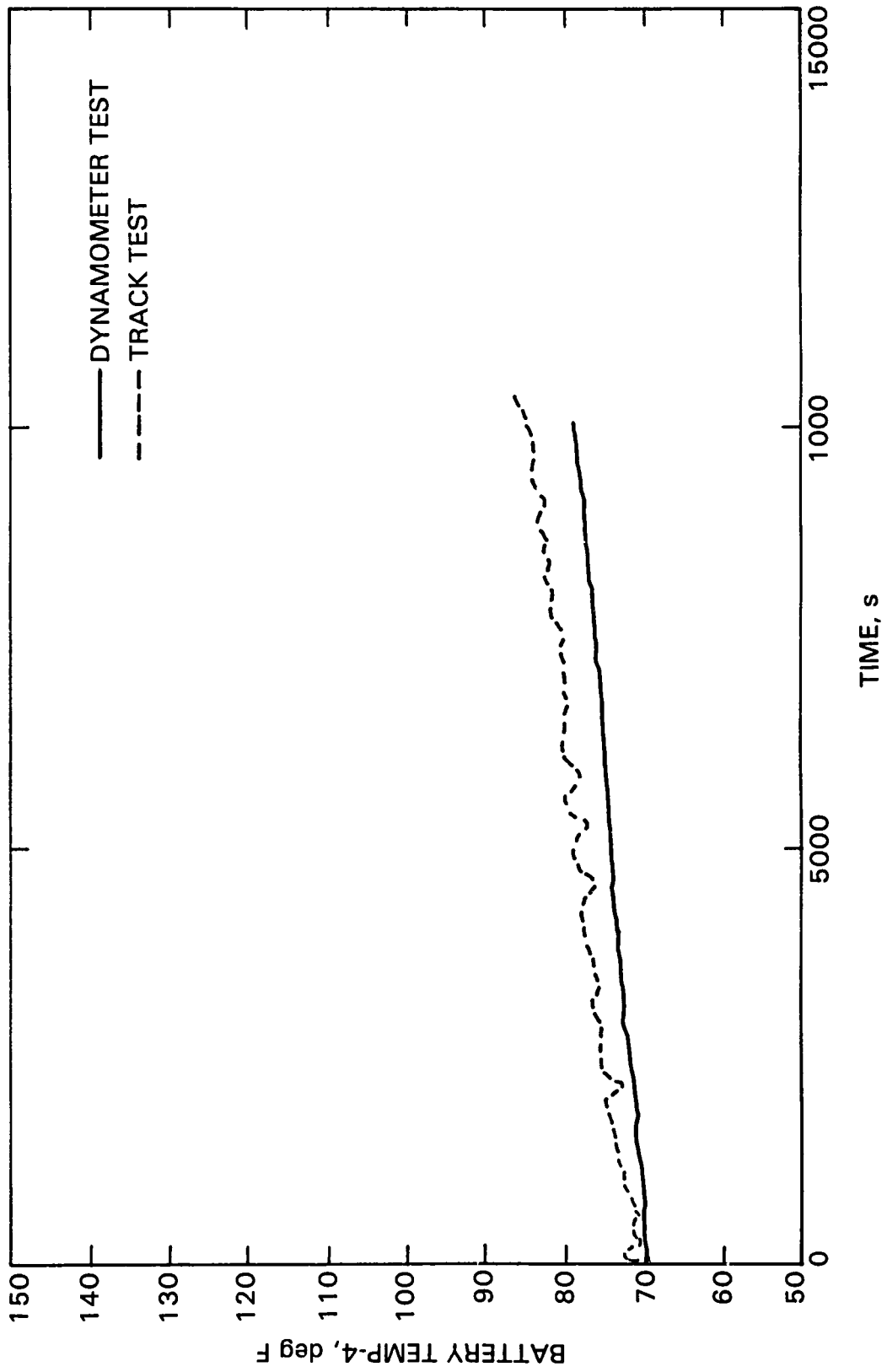

Figure B-5f.

35 mi/h

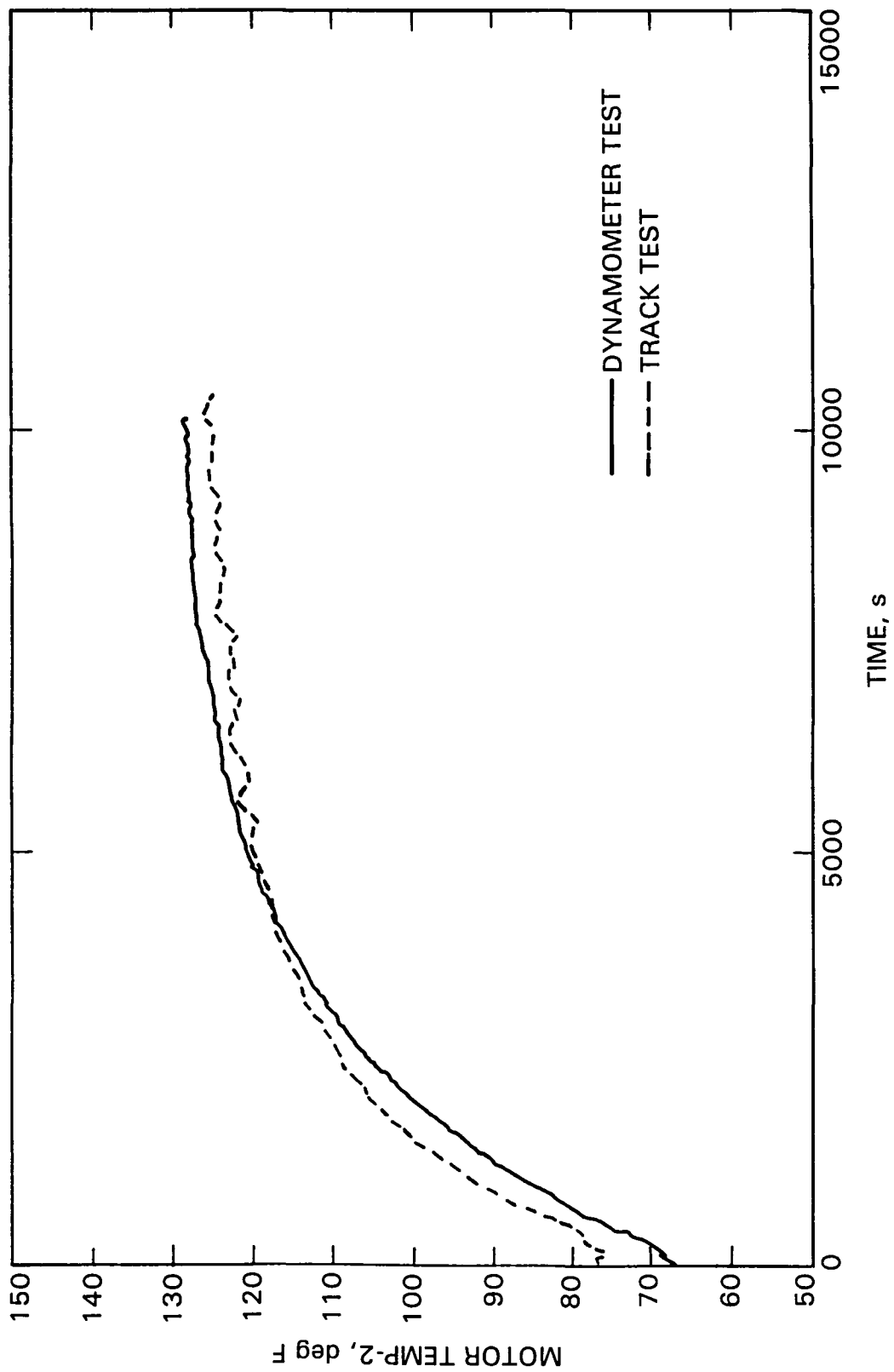

Figure B-5g.

**End of Document**