



3 1176 00509 3423

NASA-CR-172125
19830018543

NASA CONTRACTOR REPORT 172125

FLAT-PLATE DRAG MEASUREMENTS WITH VORTEX
GENERATORS IN TURBULENT BOUNDARY LAYER

D. M. RAO AND S. C. MEHROTRA

VIGYAN RESEARCH ASSOCIATES, INC.
HAMPTON, VIRGINIA 23666

CONTRACT NAS1-16283
JUNE 1983

LIBRARY COPY

JUN 22 1983

LANGLEY RESEARCH CENTER
LIBRARY, NASA
HAMPTON, VIRGINIA

NASA
National Aeronautics and
Space Administration
Langley Research Center
Hampton, Virginia 23665



NF01853

TABLE OF CONTENTS

	<u>Page</u>
INTRODUCTION	1
EXPERIMENTAL DETAILS	2
RESULTS AND DISCUSSION	3
Obstacle-type VG	3
Wall-Mounted Vane VG (#1)	4
Elevated Vane VGs (#2)	4
CONCLUSIONS AND RECOMMENDATIONS	5
REFERENCES	5
FIGURES	7

INTRODUCTION

Several researchers (ref. 1-5) have observed, or inferred the existence of streamwise vortical elements as an integral part of the large-scale structure of turbulent boundary layers, and have speculated on their role in the periodic events ('sweeps' and 'ejections') which lead to high shear in the wall region. These observations led to the question: can this dynamical structure be significantly altered by means of a regular array (or 'net') of streamwise vortices of proper scale and spacing introduced artificially into the boundary layer so as to block the primary source of turbulent energy production over a distance of several boundary layer thicknesses. For a systematic appraisal of this idea, visual observations (such as the smoke-wire visualizations of ref. 6) of the effects of embedded vortices should ideally have been conducted initially to establish the feasibility of controlling the turbulent flow structure, followed by skin-friction measurements at varying downstream distances, with vortex generator parameters (viz. height and spanwise spacing) selected to maximize the impact on the large-scale structure. However, the constraints of man-hours and facility time available for this preliminary effort only allowed limited drag-balance experiments with a few arbitrarily chosen vortex generator configurations in the NASA Langley 7 x 11 in. low speed tunnel, which has been extensively utilized in the viscous drag reduction research program. It was hoped that these exploratory experiments might be helpful towards identifying any arrangements of three-dimensional, wall-mounted elements which promised a level of friction-drag reduction comparable with those obtained by Hefner (ref. 8) with two-dimensional LEBUs. If the friction-drag as

well as the parasite drag were found to be competitive with LEBUs, the three-dimensional elements would have the advantage of being more robust in practical application.

Experimental Details

The Langley 7 x 11 in. low speed facility has been described in previous literature (most recently in ref. 7). In the present tests, a portion of the test-section floor 19.5 inch in length formed the metric flat plate, which was supported on a drag balance and separated by very narrow gaps from the rest of the test-section structure. All the gaps were contained inside a plenum box, whose pressure was automatically maintained equal to the test-section static pressure in order to minimize the effects of flow through the gaps. The metric plate was constructed of 0.5 inch thick acrylic sheet and incorporated a spanwise magnetic strip near the leading edge, flush with the flow surface, for the purpose of holding a row of vortex generators. For the measurement of plate drag alone, i.e. excluding the drag of vortex generators, the latter were moved to a position just upstream of the leading edge and held to the non-metric surface by double-faced adhesive tape. This tape was present throughout the tests to ensure constant boundary layer conditions. A schematic of the test arrangement is shown in fig. 1.

The vortex generation mechanisms are shown in fig. 2. The obstacle-type devices (0.04 in. thick circular discs and equilateral triangles) were intended to generate the well known 'hair-pin' vortices through upstream separation, thus producing a counter-rotating vortex pair trailing downstream from each element. Two vane-type vortex generators (as conventionally used for delaying boundary-layer separation) were

tested in co-rotating configurations, one wall-mounted and the other supported at a distance from the wall (elevated VG), Fig. 3.

In addition to drag measurements, limited boundary layer velocity profiles were also obtained using a traversing pitot probe, both at the plate leading-edge and at a downstream location, the latter to acquire some indirect evidence of vortex wake formation behind the obstacle type vortex generators. A typical set of profiles presented in fig. 4, is consistent with the contra-rotating vortex wake generated by obstacle devices. Limited surface flow visualizations using kerosene-lamp black mixture were conducted for more direct indication of the vortex wakes.

RESULTS AND DISCUSSIONS

The boundary layer plate drag with vortex generators (either on-plate or off-plate) was normalized by the 'clean' plate drag C_{D_0} (i.e. vortex generators off). The reference drag value was derived from root-mean-square fit through several clean-plate data sets. The ratio C_D/C_{D_0} plotted versus Reynolds no. based on the plate length is presented in figs. 5 through 11. These selected results are representative of the different types of vortex generators tested.

i) Obstacle-type VG

The results with 0.04 in. thick circular discs of 0.2 in. diameter at 0.5 in. spacing, and 0.4 in. diameter at 1.0 in. spacing are shown in figs. 5 and 6 respectively. In both cases, a 2% to 3% reduction in drag is found on the plate downstream of the discs. This shows that the momentum defect in the wake of the obstacles predominates over the high-shear generated under the streamwise vortices. These figures also show the total drag (plate plus vortex generators) which is about

5% above the basic plate drag.

A comparison of circular and triangular elements at 1.0 in. spacing is presented in fig. 7. Although the plate drag is virtually the same in both cases, the total drag is greater with the discs because of their greater pressure drag in comparison with the triangular elements.

ii) Wall-Mounted Vane VG (#1)

The effect of vane incidence angle (α) on the total drag at 1.0 in. spacing is shown in fig. 8. The effect of vane spacing at 10 deg. incidence is indicated in fig. 9. It is noted that when going from 1 in. spacing (11 VGs) to 0.5 in. spacing (21 VGs) the total drag is increased by less than 2%. It is inferred that the plate skin-friction reduction due to the higher momentum defect behind 0.5 in. spaced VGs substantially compensated for the greater pressure drag of the denser array. With 0.5 in. spaced VGs, the plate skin friction is hardly changed as shown in fig. 10, presumably due to the compensating effect of the wake momentum defect alternating with increased surface shear under the vortices.

iii) Elevated Vane VGs (#2)

These larger vortex generators located near the boundary layer edge (i.e. in a region of higher dynamic pressure) would be expected to produce higher drag as well as more intense vortices. Data for 1.0 in. and 0.5 in. spacing are shown in fig. 11. At the closer VG spacing, the plate drag is substantially decreased at the lower Reynolds numbers when the boundary layer is relatively much thicker than the VG height.

CONCLUSIONS AND RECOMMENDATIONS

The limited range of longitudinal vortex-generating devices tested did not reveal any trends towards a reduction in the flat plate turbulent skin friction. This result is in agreement with the conclusion of a somewhat similar study (ref. 9) which became available after the present experiments had been completed. However, before the role of artificially generated longitudinal vortices in altering the coherent structure can be rejected outright, the scale of the vortices relative to the turbulent boundary layer parameters that are likely to have the most impact on the conditions near the wall need to be evaluated in greater detail.

Further, detailed visualization studies with properly-scaled vortices embedded at different levels in the boundary layer should be attempted in order to obtain an insight into the controlled interactions of useful lifetimes that are possible. The drag measurements obtained with different types of vortex generators are of some value in estimating the parasitic drag when considering boundary-layer modification applications other than for reducing skin friction, e.g. for reduction of radiated noise from turbulent boundary layers or free shear layers.

REFERENCES

1. Clark, J. A. and Markland, E.; "Vortex Structures in Turbulent Boundary Layers," Aero. Journal, March 1970, pp. 243-244.
2. Praturi, A. K. and Brodkey, R. S.; "A Stereoscopic Visual Study of Coherent Structures in Turbulent Shear Flow," J. Fluid Mech. (1978), Vol. 89, part 2, 251-272.

Not AIAA

3. Blackwelder, R. F. and Eckelman, H.; "Streamwise Vortices Associated with the Bursting Phenomenon," J. Fluid Mech. (1979), Vol. 94, part 3, pp. 577-594.
4. Bandyopadhyaya, P. and Head, M. R.; "A Unified View of Turbulent Boundary Layer Structure," 6th Biennial Symposium on Turbulence, Rolla, MO, Oct. 1979.
5. Falco, R.; "The Production of Turbulence Near a Wall," AIAA Paper No. 80-1356, July 1980.
6. Corke, T. C., Guezennec, Y. and Nagib, H. M.; "Modification in Drag of Turbulent Boundary Layers Resulting from Manipulation of Large-Scale Structures," Viscous Drag Reduction, Vol. 72 Progress in Astronautics and Aeronautics (1979), pp. 128-143.
7. Walsh, M. J.; "Turbulent Boundary Layer Drag Reduction Using Riblets," AIAA Paper No. 82-0168, 1982.
8. Hefner, J. N., Weinstein, L. M. and Bushnell, D. M.; "Large Eddy Breakup Scheme for Turbulent Viscous Drag Reduction," Viscous Drag Reduction, Vol. 72, Progress in Astronautics and Aeronautics (1979), pp. 110-127.
9. Sandborn, V. A.; "Aerodynamic Control of Surface Shear Stress Fluctuations in Turbulent Boundary Layers," CSU No.-CER 80-81-HC-VAS-46, April 1981.

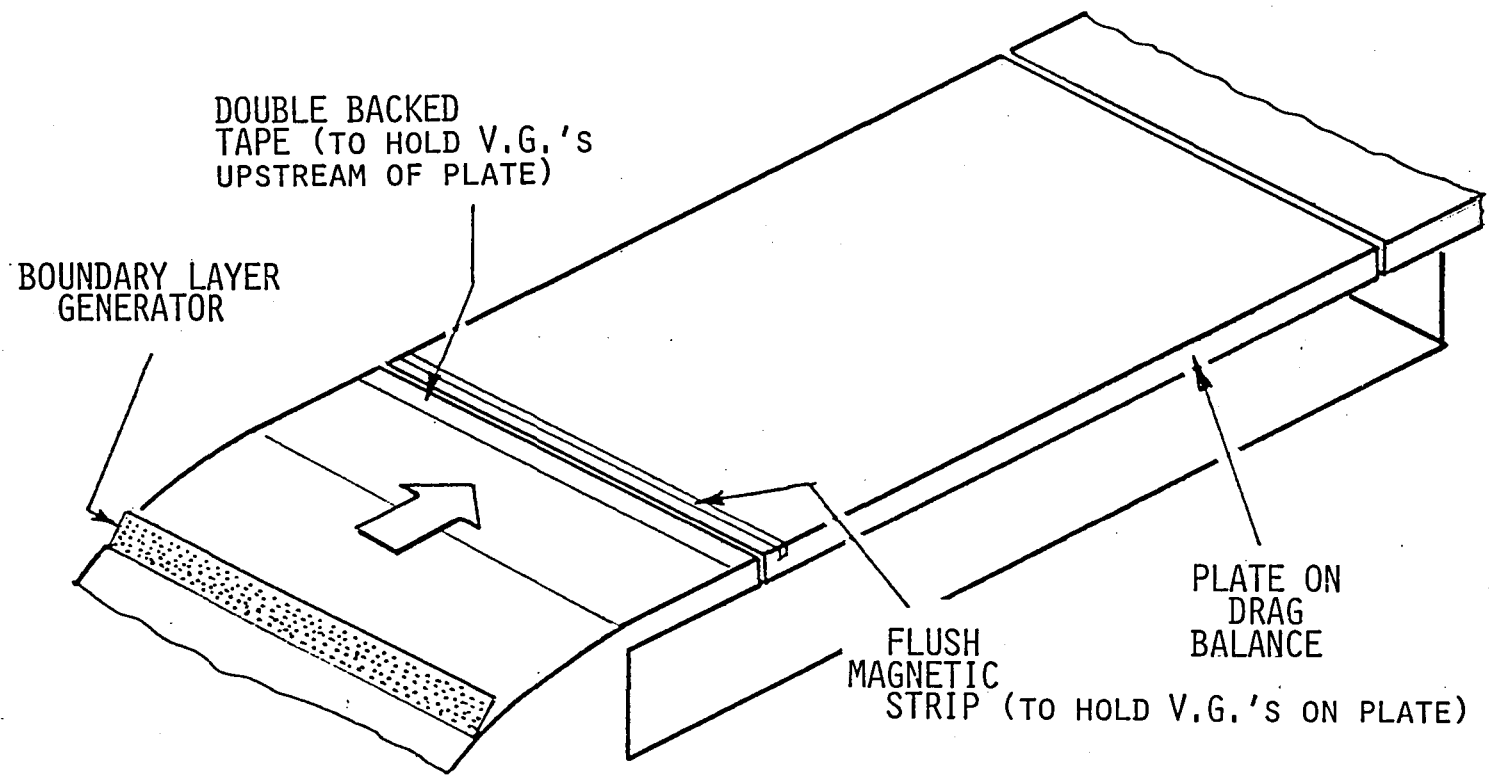
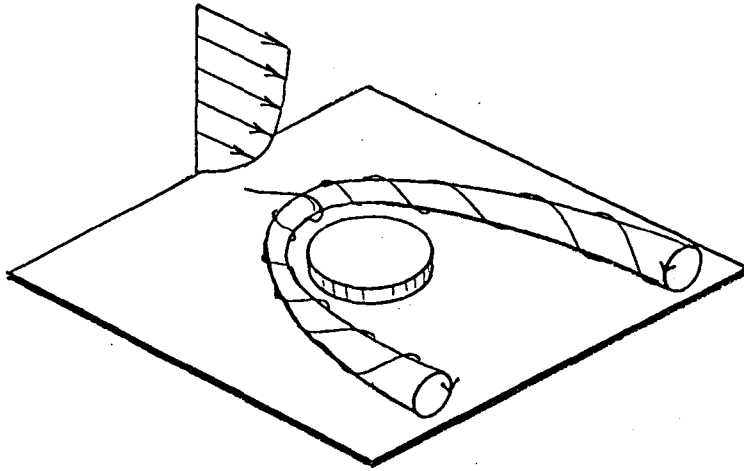
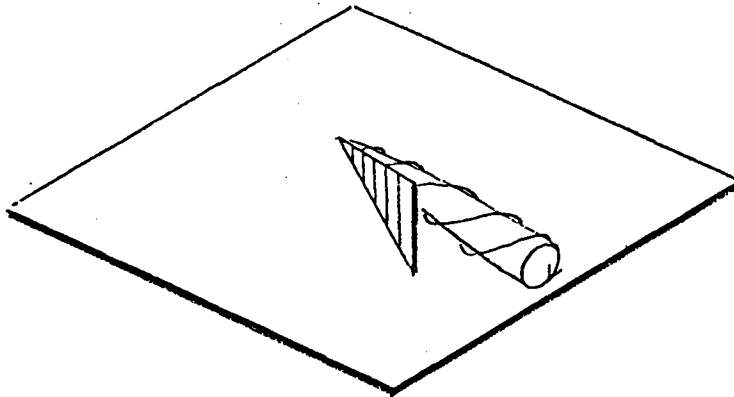

Figure 1. Schematic of test set-up in Langley 7 in. x 11 in. low speed facility



OBSTACLE



WALL-MOUNTED
VANE

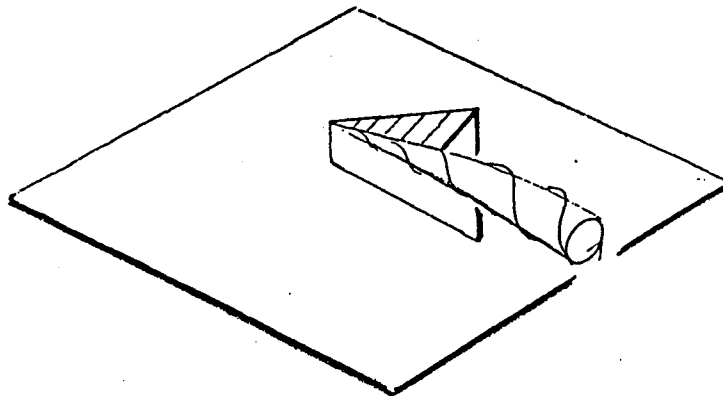

ELEVATED VANE

Figure 2. Vortex generating mechanisms

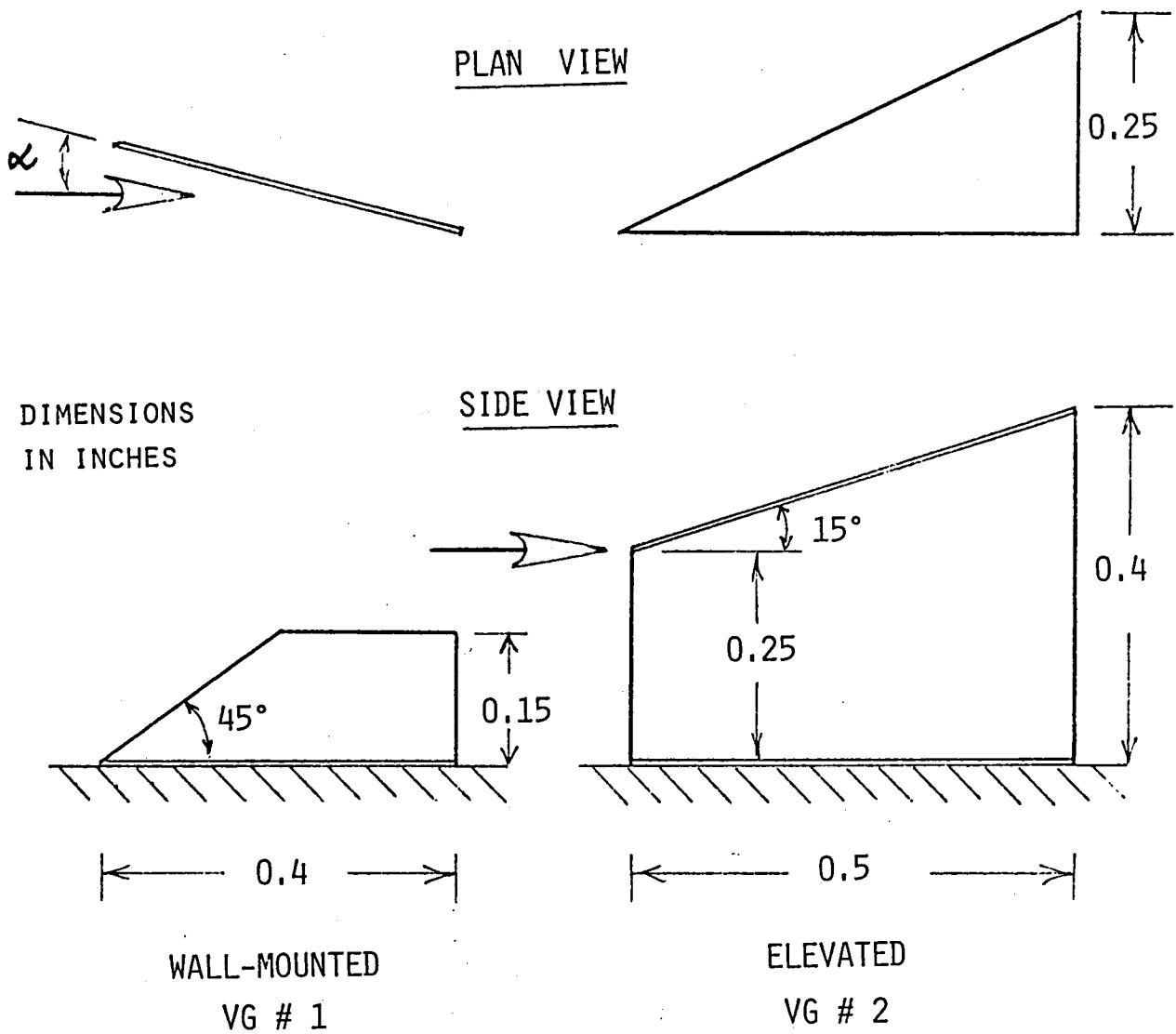

Figure 3. Vane-type vortex generators

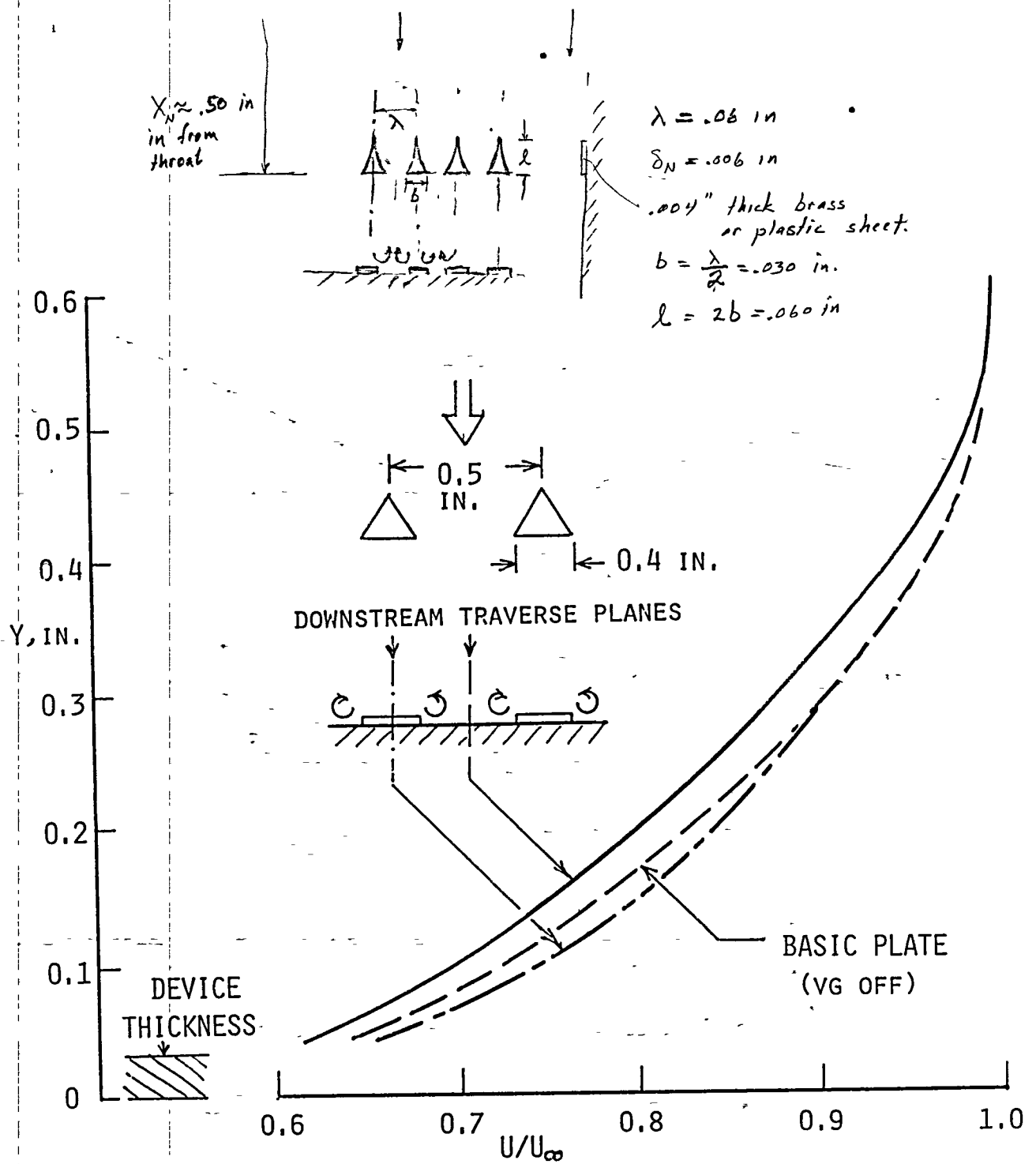

Figure 4. Boundary layer velocity profiles on plate 10 in. downstream of array of triangular elements

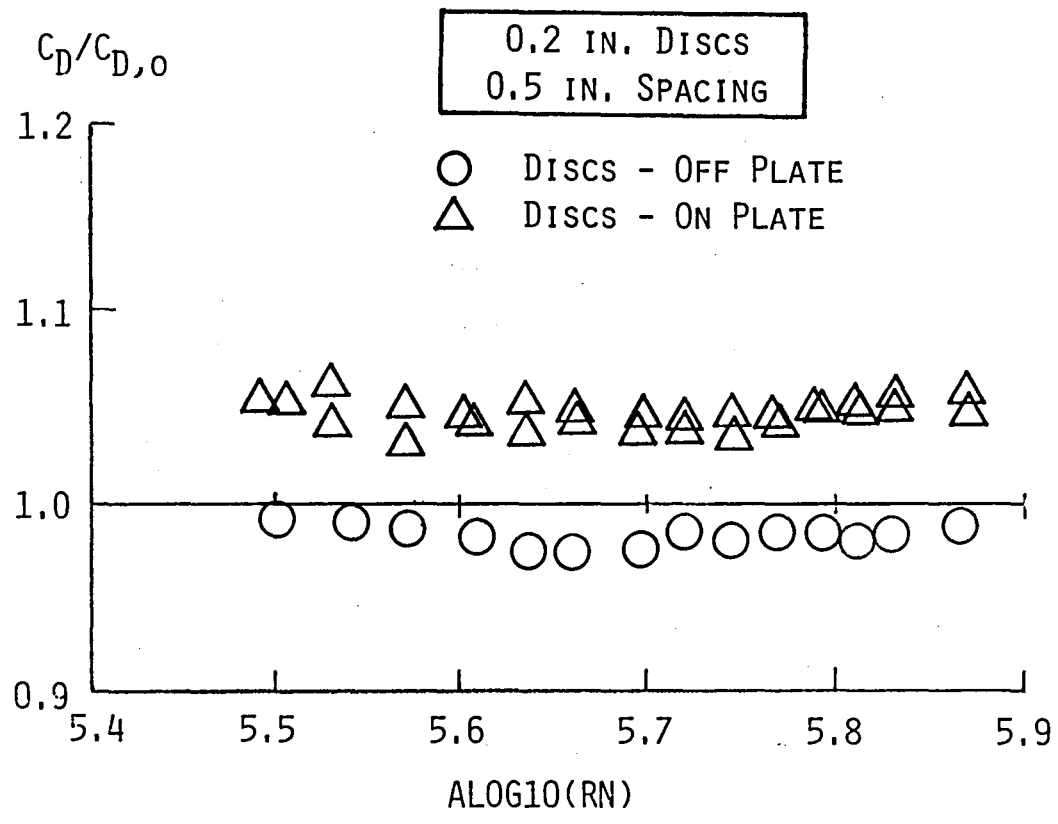

Figure 5. Drag results with 0.2 in. dia. discs at 0.5 in. spacing

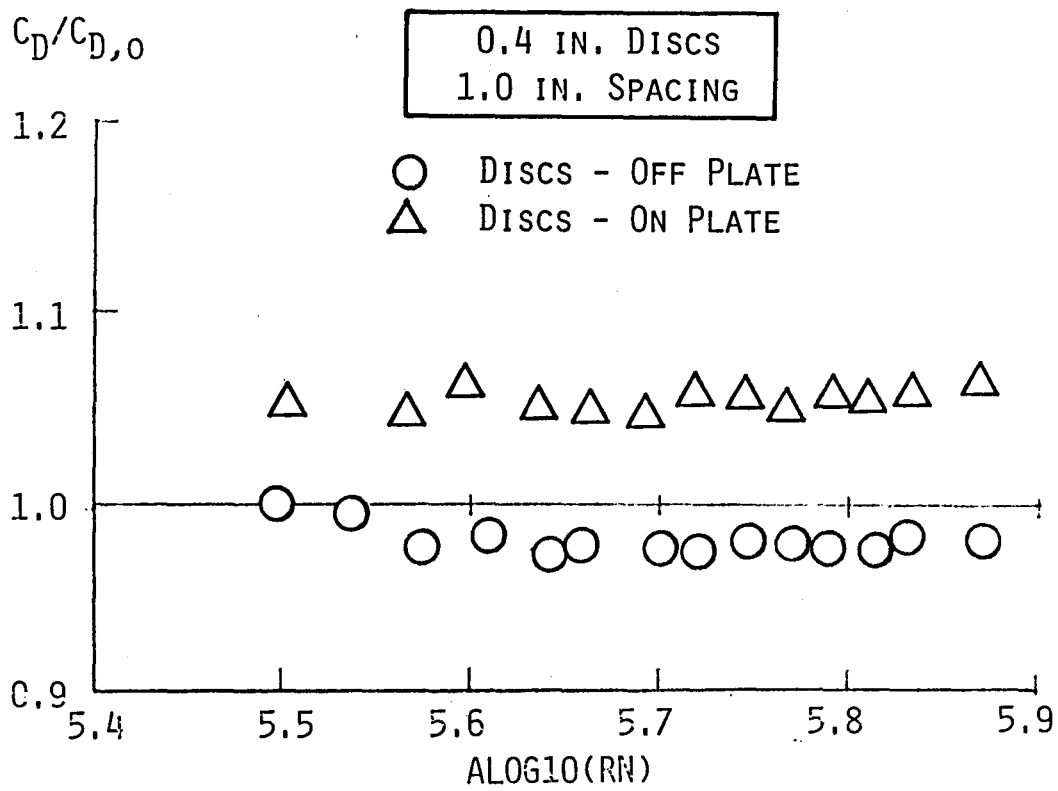

Figure 6. Drag results with 0.4 in. dia. discs at 1.0 in. spacing

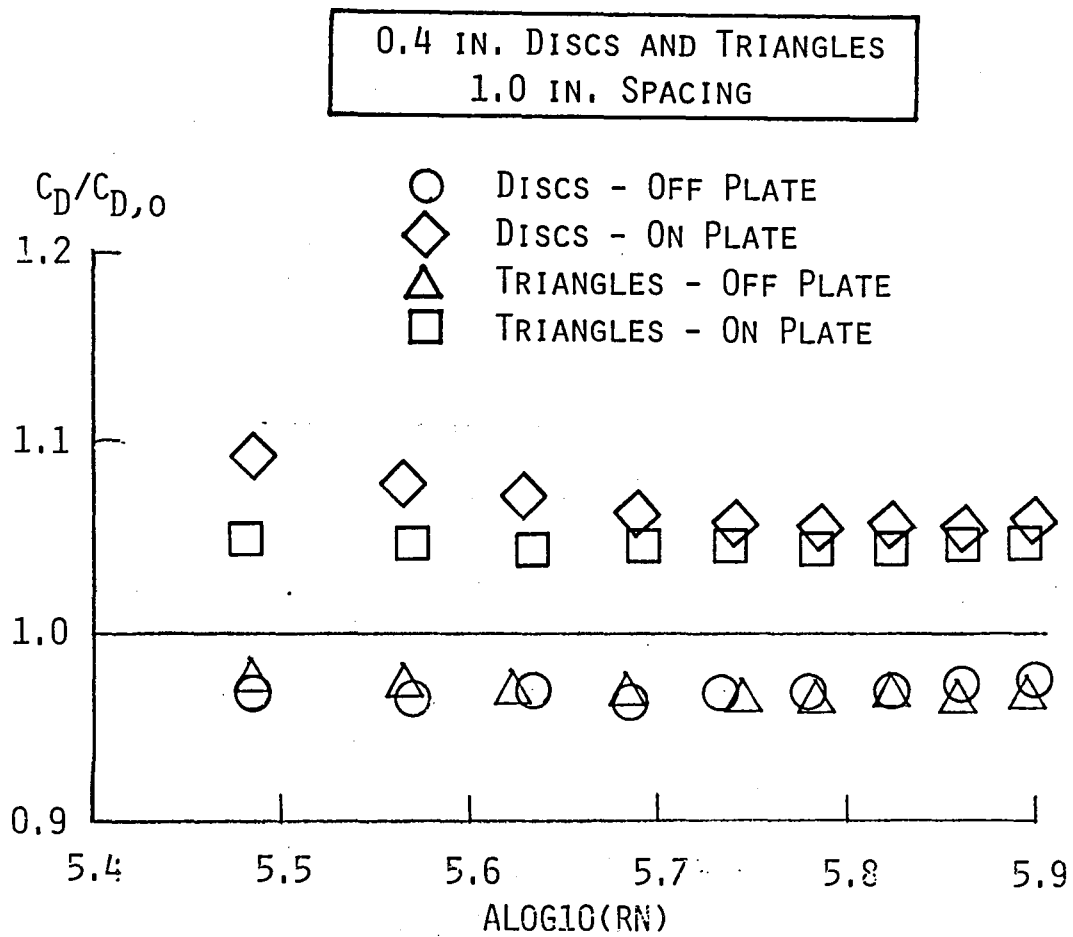

Figure 7. Comparison of drag results with 0.4 in. discs and triangles at 1.0 in. spacing

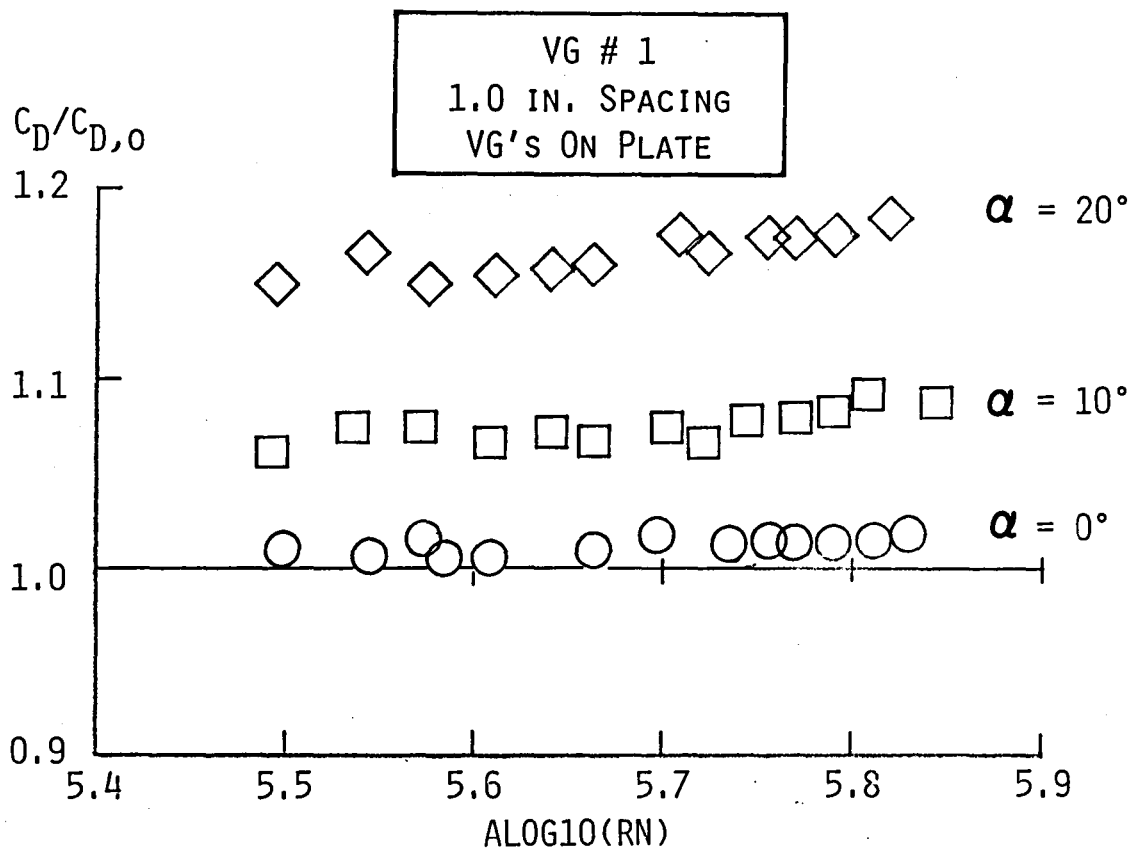

Figure 8. Drag results with vane-type VG(#1) at 1.0 in. spacing showing effect of incidence angle

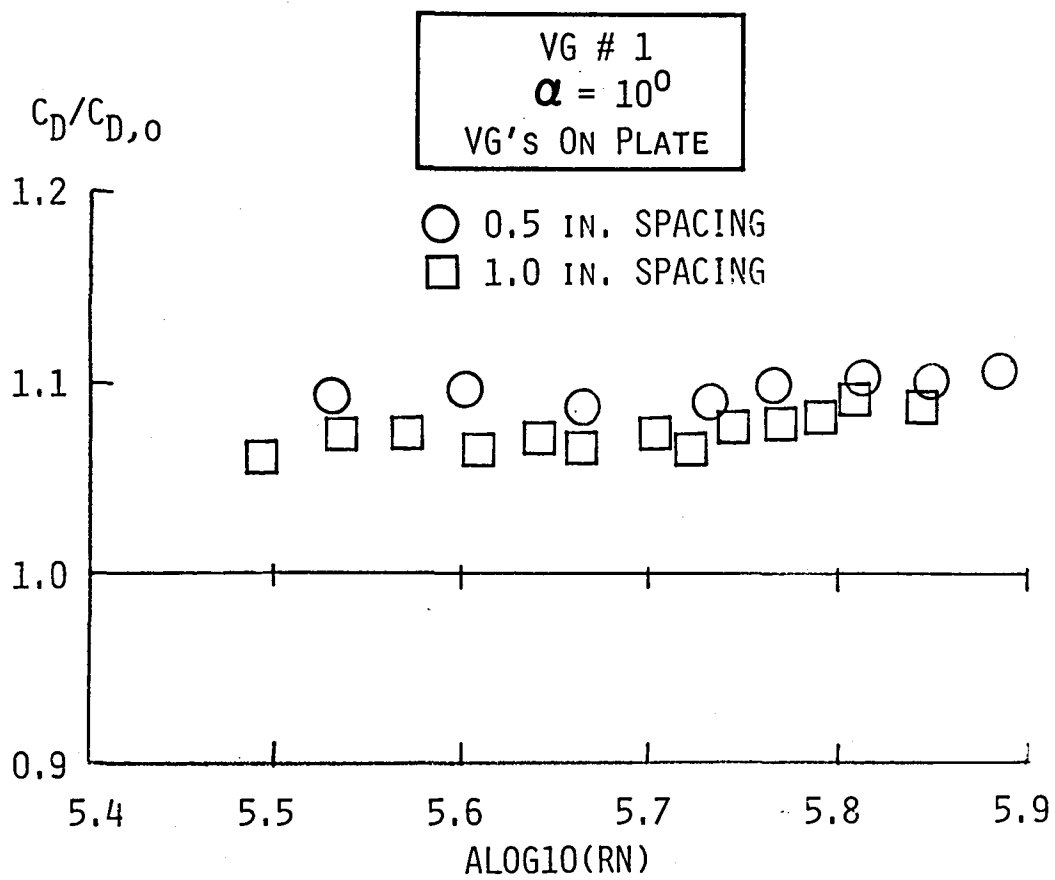

Figure 9. Drag results with vane-type VG(#1) showing effect of spacing

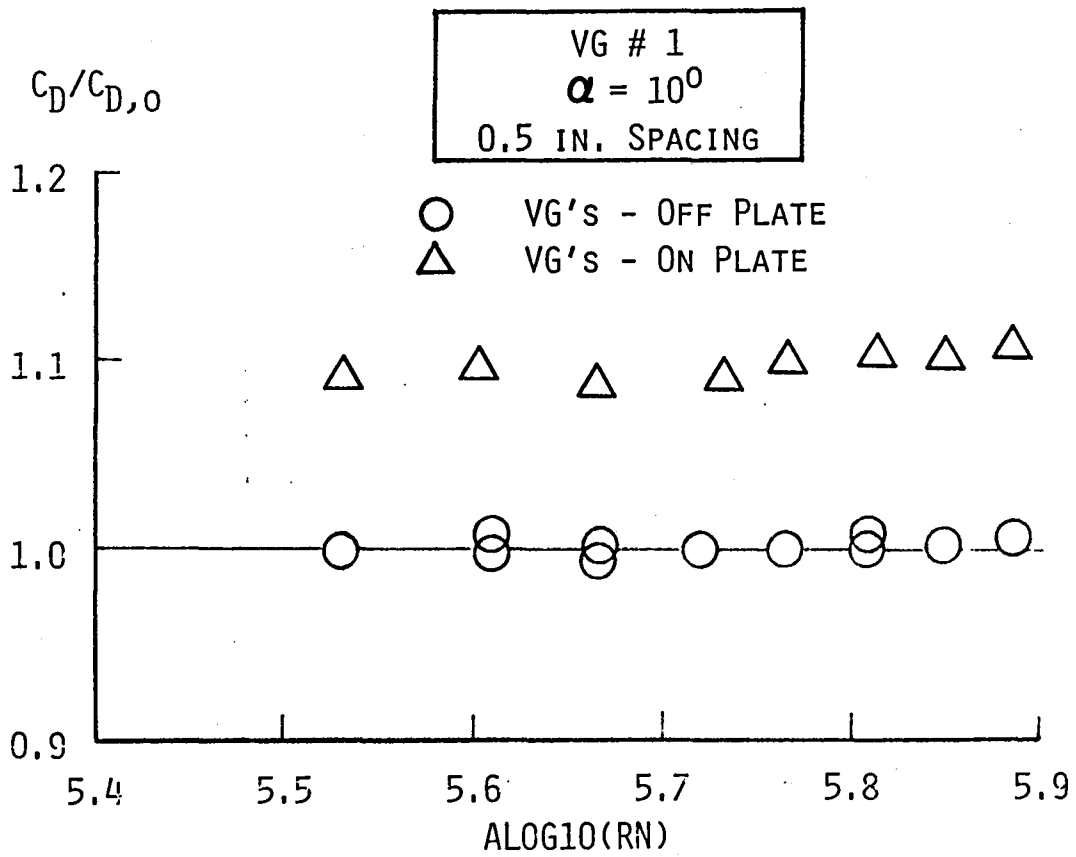

Figure 10. Drag results with vane-type VG(#1) on and off plate

VG # 2

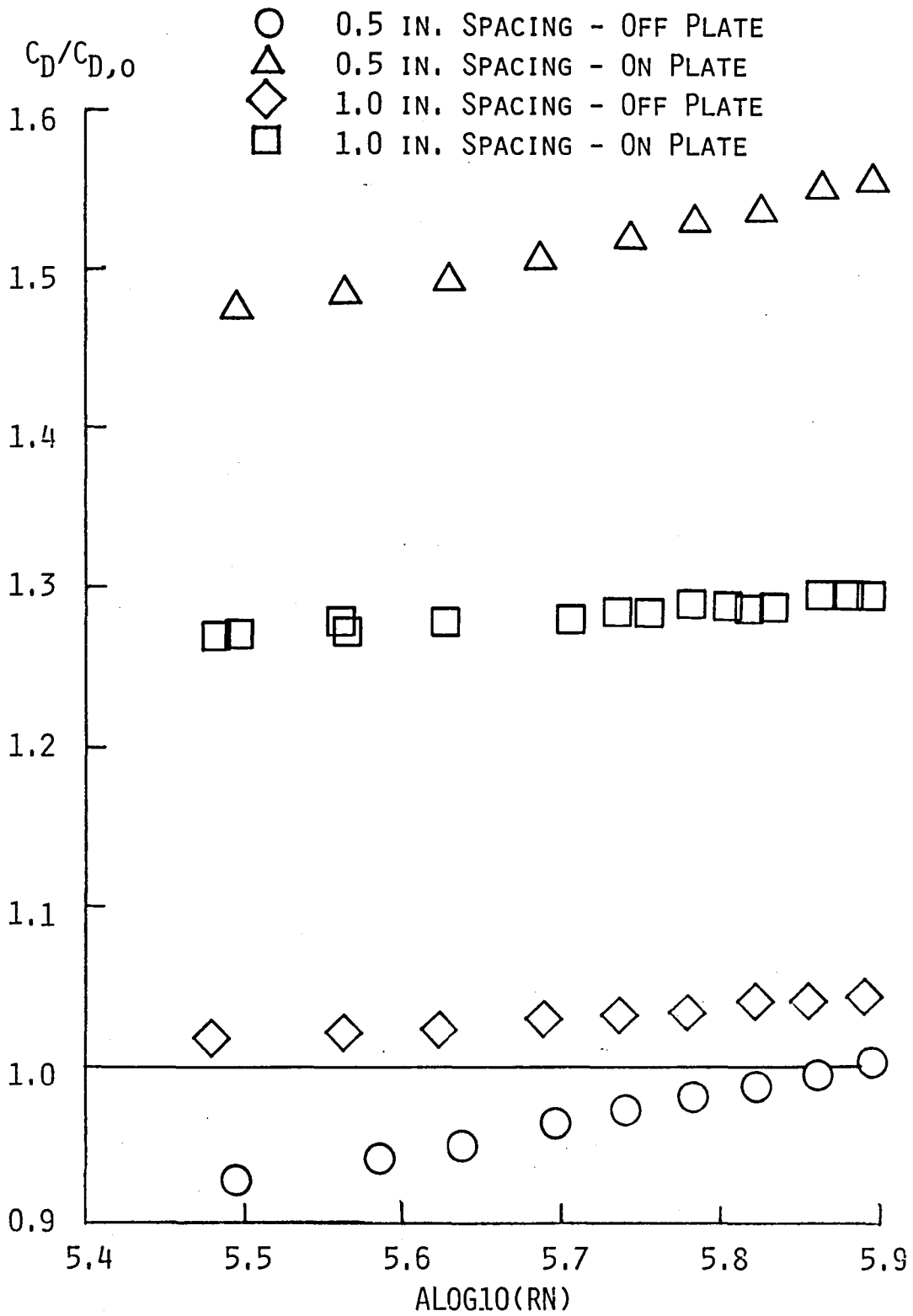

Figure 11. Drag results with vane-type VG(#2) on and off plate showing effect of spacing

1. Report No. NASA CR-172125		2. Government Accession No.		3. Recipient's Catalog No.	
4. Title and Subtitle FLAT-PLATE DRAG MEASUREMENTS WITH VORTEX GENERATORS IN TURBULENT BOUNDARY LAYER				5. Report Date June 1983	
				6. Performing Organization Code	
7. Author(s) D. M. Rao and S. C. Mehrotra				8. Performing Organization Report No. ViRA-83-01	
9. Performing Organization Name and Address Vigyan Research Associates, Inc, 28 Research Drive Hampton, VA 23666				10. Work Unit No.	
				11. Contract or Grant No. NAS1-16283	
12. Sponsoring Agency Name and Address NASA Langley Research Center Hampton, VA 23665				13. Type of Report and Period Covered Contractor Report 07/01/80 to 04/30/83	
				14. Sponsoring Agency Code	
15. Supplementary Notes Langley Technical Monitor, Jerry N. Hefner Final Report					
16. Abstract Direct drag measurements were obtained on a flat plate with a spanwise row of vortex generators near the leading edge, to produce an array of stream-wise vortices within the approaching turbulent boundary layer. The object was to explore the possibility of modifying the large-scale structure of the boundary layer through embedded longitudinal vortices with a view to obtaining a reduction in wall shear. Both obstacle and vane-type vortex generators were tested at free-stream velocities 40 ft/sec to 130 ft/sec corresponding to plate-length Reynolds no. 0.3×10^6 to 0.8×10^6 with a nominal boundary layer thickness of approximately 0.6 in. at the leading edge. A few vortex-generator configurations were tested both on and off the plate to measure the total drag as well as the plate drag alone. The obstacle-type devices reduced the plate drag, indicating that the wake momentum defect predominated even in the presence of streamwise vortices. The vane-type vortex generators however always increased the plate drag.					
17. Key Words (Suggested by Author(s)) Vortex generators (V.G.'s) Boundary layer Drag measurements				18. Distribution Statement Unclassified-Unlimited	
19. Security Classif. (of this report) Unclassified		20. Security Classif. (of this page) Unclassified		21. No. of Pages 17	22. Price

End of Document