

NASA-CR-168,035  
19830018856



**NASA NO. CR-168035**

10 March 1983

MLR-1430

# **HIGH FREQUENCY, HIGH POWER CAPACITOR DEVELOPMENT FINAL REPORT**

This work sponsored by the National Aeronautics  
and Space Administration, Lewis Research Center  
under Contract NAS3-22668

Submitted to

National Aeronautics and Space Administration  
Lewis Research Center  
Propulsion and Power Station  
21000 Brookpark Road  
Cleveland, Ohio 44135

LIBRARY COPY

Prepared by

Maxwell Laboratories, Inc.  
8835 Balboa Avenue  
San Diego, California 92123

NASA NO CR-168035



NASA NO. CR-168035

MLR-1430

10 March 1983

**HIGH FREQUENCY, HIGH POWER CAPACITOR DEVELOPMENT**

**FINAL REPORT**

This work sponsored by the National Aeronautics  
and Space Administration, Lewis Research Center  
Under Contract NAS3-22668

Submitted to

National Aeronautics and Space Administration  
Lewis Research Center  
Propulsion and Power Station  
21000 Brookpark Road  
Cleveland, Ohio 44135

\*

Prepared by

Maxwell Laboratories, Inc.  
8835 Balboa Avenue  
San Diego, California 92123

N83-27127#

1. Report No. NASA CR-168035		2. Government Accession No.		3. Recipient's Catalog No.	
4. Title and Subtitle High Frequency, High Power Capacitor Development				5. Report Date March 1983	
				6. Performing Organization Code	
7. Author(s) C. Wayne White Paul S. Hoffman				8. Performing Organization Report No. MLR-1430	
				10. Work Unit No.	
9. Performing Organization Name and Address Maxwell Laboratories, Inc. 8835 Balboa Ave. San Diego, Ca. 92123				11. Contract or Grant No. NAS3-22668	
				13. Type of Report and Period Covered Contractor Final Report	
12. Sponsoring Agency Name and Address NASA-Lewis Research Center 21000 Brookpark Road Cleveland, Ohio 44135				14. Sponsoring Agency Code	
15. Supplementary Notes					
16. Abstract					
<p>A program to develop a special high energy density, high power transfer capacitor to operate at frequency of 40 kHz, 600 V rms at 125 A rms plus 600 V dc bias for space operation. The program included material evaluation and selection, a capacitor design was prepared, a thermal analysis performed on the design. Fifty capacitors were manufactured for testing at 10 kHz and 40 kHz for 500-hours at Industrial Electric Heating Co. of Columbus, Ohio.</p> <p>The vacuum endurance test used on environmental chamber and temperature plate furnished by Maxwell. The capacitors were energized with a special power conditioning apparatus developed by Industrial Electric Heating Co. Temperature conditions of the capacitors were monitored by IEHCo test equipment.</p> <p>Successful completion of the vacuum endurance test series confirmed achievement of the main goal of producing a capacitor or reliable operation at high frequency in an environment normally not hospitable to electrical and electronic components. The capacitor developed compared to a typical commercial capacitor at the 40 kHz level represents a decrease in size and weight by a factor of seven.</p>					
17. Key Words (continued) - Vacuum Qualified Capacitors Polypropylene Capacitors					
17. Key Words (Suggested by Author(s)) High Frequency Capacitor (40 kHz) High Power Capacitor (75 kVAR) High Energy Density Capacitor Dielectric Materials Evaluation High Current AC Capacitor (125 A rms)				18. Distribution Statement Unclassified - Unlimited	
19. Security Classif. (of this report) Unclassified		20. Security Classif. (of this page) Unclassified		21. No. of Pages 87	22. Price*

\* For sale by the National Technical Information Service, Springfield, Virginia 22161

MLA-4508

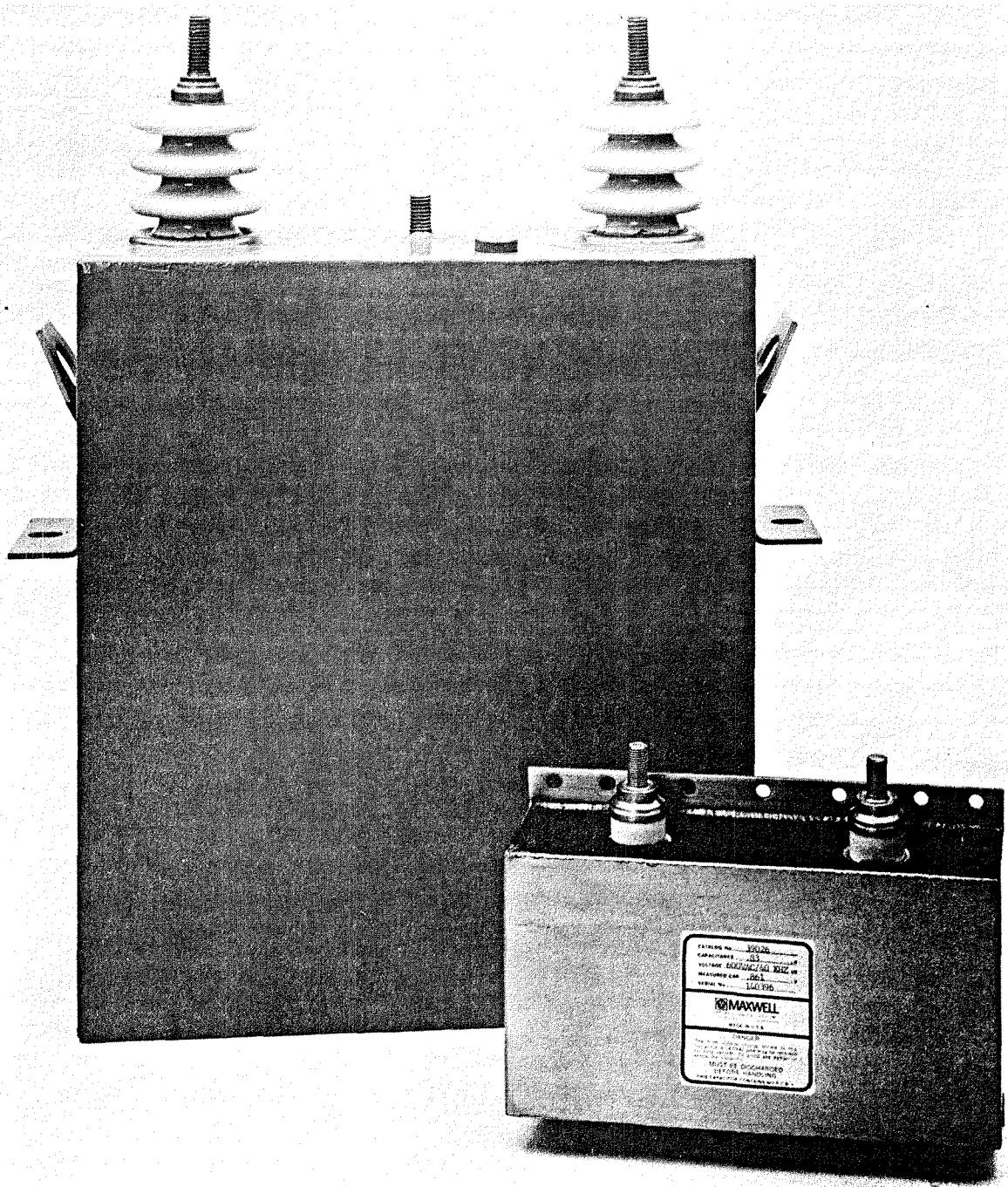

## FOREWORD

This document is the final report of the capacitor development work carried out by Maxwell Laboratories, Inc., under Contract Number NAS3-22668 for the National Aeronautics and Space Administration. Maxwell Laboratories completed the evaluation of dielectric materials, and designed and manufactured the capacitors tested for performance under the requirements of the contract Statement of Work. Arrangements were made by Maxwell with Industrial Electric Heating Co. (IEHCo) of Columbus, Ohio, to carry out the Vacuum Endurance Tests stipulated in the SOW, using an environmental chamber and temperature plate furnished by Maxwell. The capacitors were energized by means of special power conditioning apparatus developed by Industrial Electric Heating, Co., and temperature conditions of the specimen capacitors were monitored by IEHCo test equipment.

Mr. David Renz was the NASA Program Monitor for this contract. Mr. Wayne White was the Maxwell Program Manager. Nancy Nelson wound the capacitor windings, and with Isabel Castruita, soldered and assembled the capacitors. Rick Brown assisted in the corona tests and epoxy casting. Chuck Miller accomplished the specialized welding of the bushings and cases. Mr. Paul Hoffman served as consultant to Maxwell for the program. The testing at IEHCo was under the direction of Mr. Edwin Mason and Mr. Dave Ellebruch.

## SUMMARY

This document describes the results of a concerted technical effort by Maxwell Laboratories, Inc. personnel to produce special high energy density, high power transfer capacitors at the 600 V rms, 125 A rms level, for ultimate service in space vehicles. The capacitors are to be employed in continuous high frequency alternating current power conditioning applications, and are designed to operate in a highly reliable manner without supplementary cooling facilities for a period of five years. The environment of operation includes service in vacuum, and over a wide temperature range. Although specific temperature limits were not defined in the Statement of Work, the capacitor materials examined were tested over a temperature range of  $-40^{\circ}\text{C}$  to  $+125^{\circ}\text{C}$ .

After a period of material evaluation and selection, a capacitor design was prepared, a thermal analysis performed on the design, and sufficient capacitors manufactured to satisfy the test requirement of the contract. Arrangements were made between Maxwell Laboratories and Industrial Electric Heating Co. of Columbus, Ohio, for the conduct of electrical tests at high frequency and low ambient pressure, under ac, and a combination of ac and dc voltages for a period of 500 hours. Tests under continuous duty at 10 kHz, 600 V rms at 30 A rms and 10 micron pressure, in accordance with the specified conditions of the Vacuum Endurance Test of the Statement of Work, were completed without capacitor failure. A second test at a frequency of 40 kHz, 600 V rms at 125 A rms plus 600 V dc was also accomplished on a second set of capacitors with a single failure reported.

Successful completion of the Vacuum Endurance Test series confirmed achievement of the main goal of producing capacitors capable of reliable operation at high frequency in an environment normally not hospitable to electrical and electronic components. The degree of attainment of high energy density - or high power density - can be ascertained by comparison of the performance of the test capacitors with state-of-the-art power factor capacitors now being used by the nation's electrical utility customers.

The modern all-film power factor correction capacitor being put into service by the electrical utilities has an energy/power density of approximately 1.75 kVAR/pound when used at full electrical rating. The capacitors developed in the subject contract have a power density of approximately 11 kVAR per pound when in service at a frequency of 40 kHz, and 2.5 kVAR per pound at 10 kHz. The capacitor developed in the program compared to a typical commercial capacitor at the 40 kHz level is shown on the frontispiece. This represents a decrease in size and weight by a factor of seven.

The objectives of this development contract were achieved without the development of new dielectric materials, or the origination of esoteric techniques or procedures. A capacitor design was conceived which enabled the production of capacitors capable of operating in a deep space environment with

predictable efficiency and reliability. In addition, the materials evaluation yielded data which will be useful in expanding the capabilities of subsequent capacitors produced for similar applications. The power transfer capability of the capacitors has established a viable bench mark from which improved energy-density capacitors can be developed.

## TABLE OF CONTENTS

FRONTISPIECE. . . . .		ii
FOREWORD. . . . .		iii
SUMMARY . . . . .		iv
1. INTRODUCTION . . . . .		1-1
1-1 General. . . . .		1-1
1-2 Technical. . . . .		1-1
2. TASK I - ANALYSIS - DESCRIPTION OF MATERIALS . . . . .		2-1
2-1 Task I - Analysis - Tests of Materials . . . . .		2-7
3. TASK II - FINAL CAPACITOR DESIGN . . . . .		3-1
3-1 The Capacitive Elements. . . . .		3-1
3-2 The Conductor/Element Assembly . . . . .		3-4
3-3 The Capacitor Case and Termination . . . . .		3-4
3-4 The Thermal Analysis of Design . . . . .		3-10
4. CAPACITOR MANUFACTURING. . . . .		4-1
5. CORONA MEASUREMENTS. . . . .		5-1
6. ENDURANCE TESTING. . . . .		6-1
6-1 Test Plan. . . . .		6-1
6-2 Test Program . . . . .		6-1
6-3 Test Facility Checkout . . . . .		6-4
6-3.1 500-Hour Vacuum Endurance Test at 10 kHz. . . . .		6-13
6-3.2 40 kHz Endurance Test with Modified Bushings. . . . .		6-28
6-3.3 The Qualification Test on the Final Version Capacitor . . . . .		6-38
7. SECOND GENERATION (Phase II) CAPACITOR DESIGN. . . . .		7-1

## LIST OF FIGURES

2-1	Temperature coefficient of capacitance - Lot #1. . . . .	2-10
2-2	Temperature coefficient of capacitance - Lot #2. . . . .	2-11
2-3	Temperature coefficient of capacitance - Lot #3. . . . .	2-12
2-4	Temperature coefficient of capacitance - Lot #4. . . . .	2-13
2-5	Temperature coefficient of capacitance - Lot #5. . . . .	2-14



2-6	Temperature coefficient of dissipation factor. . . . .	2-15
2-7	Temperature coefficient of dissipation factor. . . . .	2-16
3-1	Capacitor element detailed . . . . .	3-2
3-2	Capacitor element. . . . .	3-5
3-3	Capacitor element assembly . . . . .	3-6
3-4	40 kHz capacitor outline . . . . .	3-7
3-5	Capacitor insulators . . . . .	3-8
3-6	Electrode/insulator assemblies . . . . .	3-9
4-1	Capacitor pad test fixture . . . . .	4-3
5-1	Circuit to evaluate dc biasing . . . . .	5-3
6-1	Vacuum endurance test diagram. . . . .	6-2
6-2	Vacuum Endurance Test Facility . . . . .	6-5
6-3	Vacuum tank external capacitor and resonate coil . . . . .	6-6
6-4	Test capacitors mounted to cool plate. . . . .	6-7
6-5	Vacuum endurance checkout diagram. . . . .	6-8
6-6	Thermocouple locations . . . . .	6-9
6-7	Initial test at 600 V ac at 10 kHz 72° water temperature . . . .	6-10
6-8	Thermocouple locations . . . . .	6-11
6-9	Capacitor location for 20 kHz test . . . . .	6-14
6-10	Thermocouple locations for 20 kHz test . . . . .	6-15
6-11	Capacitor temperature rise at 20 kHz . . . . .	6-16
6-12	Capacitor location for 500-hour Vacuum Endurance Test. . . . .	6-17
6-13	Thermocouple locations for 500-hour Vacuum Endurance Test. . . .	6-18
6-14	Vacuum Endurance Test temperature rise values of thermocouples .	6-22
6-15	Voltage/frequency coefficient of power transfer. . . . .	6-25
6-16	40 kHz test with 300 amp fuses . . . . .	6-30
6-17	40 kHz test with No. 0000 cables . . . . .	6-32
6-18	Test circuit diagram at 40 kHz ac with dc bias in vacuum . . . .	6-34
6-19	External mounted capacitors for 40 kHz with dc bias. . . . .	6-35
6-20	Test circuit diagram at 40 kHz ac with dc bias at atmospheric pressure . . . . .	6-36
6-21	Thermocouple locations for 600 V ac, 40 kHz 500-hour endurance test . . . . .	6-37
7-1	Proposed capacitor design - Phase II . . . . .	7-4

LIST OF TABLES

2-1	Candidate Dielectric Materials . . . . .	2-2
2-2	Sample Information . . . . .	2-8
2-3	Temperature/Frequency Coefficient of Capacitance . . . . .	2-8
2-4	Temperature/Frequency Coefficient of D.F.. . . . .	2-9
5-1	RMS Voltage Values . . . . .	5-2
5-2	RMS Voltage Values with dc Bias. . . . .	5-4
6-1	Capacitance Stability after 500-Hour Test. . . . .	6-20
6-2	Electrical Measurements at Maxwell f = 120 Hz. . . . .	6-23
6-3	Power Coefficient of Temperature Rise. . . . .	6-26
6-4	Temperature Conditions from Operation with 150 Amp Fuses . . . .	6-27
6-5	Electrical Measurements at Maxwell f = 100 Hz. . . . .	6-29
6-6	Summary of Final Testing . . . . .	6-38
7-1	Capacitor Weight Analysis. . . . .	7-3

# CONVERSION FACTORS FOR U.S. CUSTOMARY TO METRIC (SI) UNITS OF MEASUREMENT

To Convert From	To	Multiply By
angstrom	Meters (m)	1.000 000 x E -10
atmosphere (normal)	Kilo pascal (kPa)	1.013 25 X E +2
bar	kilo pascal (kPa)	1.000 000 X E +2
barn	meter <sup>2</sup> (m <sup>2</sup> )	1.000 000 X E -28
British thermal unit (thermochemical)	joule (J)	1.054 350 X E +3
cal (thermochemical)/cm <sup>2</sup>	meta joule/m <sup>2</sup> (MJ/m <sup>2</sup> )	4.184 000 X E -2
calorie (thermochemical)	joule (J)	4.184 000
calorie (thermochemical)/g	joule per kilogram (J/kg)*	4.184 000 X E +3
curies	giga becquerel (Gbcq)†	3.700 000 X E +1
degree Celsius	degree kelvin (K)	$t_K = t_C + 273.15$
degree (angle)	radian (rad)	1.745 329 X E -2
degree Fahrenheit	degree kelvin (K)	$t_K = (t_F + 459.67)/1.8$
electron volt	joule (J)	1.602 19 X E -19
erg	joule (J)	1.000 000 X E -7
erg/second	watt (W)	1.000 000 X E -7
foot	meter (m)	3.048 000 X E -1
foot-pound-force	joule (J)	1.355 818
gallon (U.S. liquid)	meter <sup>3</sup> (m <sup>3</sup> )	3.785 412 X E -3
inch	meter (m)	2.540 000 X E -2
jerk	joule (J)	1.000 000 X E +9
joule kilogram (J/kg) (radiation dose absorbed)	gray (Gy)*	1.000 000
kilotons	terajoules	4.183
kip (1000 lbf)	newton (N)	4.448 222 X E +3
kip/inch <sup>2</sup> (ksi)	kilo pascal (kPa)	6.894 757 X E +3
ktap	newton-second/m <sup>2</sup> (N-s/m <sup>2</sup> )	1.000 000 X E +2
micron	meter (m)	1.000 000 X E -6
mil	meter (m)	2.540 000 X E -5
mile (international)	meter (m)	1.609 344 X E +3
ounce	kilogram (kg)	2.834 952 X E -2
pound-force (lbf avoirdupois)	newton (N)	4.448 222
pound-force inch	newton-meter (N·m)	1.129 848 X E -1
pound-force/inch	newton/meter (N/m)	1.751 268 X E +2
pound-force/foot <sup>2</sup>	kilo pascal (kPa)	4.788 026 X E -2
pound-force/inch <sup>2</sup> (psi)	kilo pascal (kPa)	6.894 757
pound-mass (lbm avoirdupois)	kilogram (kg)	4.535 924 X E -1
pound-mass-foot <sup>2</sup> (moment of inertia)	kilogram-meter <sup>2</sup> (kg·m <sup>2</sup> )	4.214 011 X E -2
pound-mass/foot <sup>3</sup>	kilogram-meter <sup>3</sup> (kg/m <sup>3</sup> )	1.061 846 X E +1
rad (radiation dose absorbed)§	gray (Gy)*	1.000 000 X E -2
roentgen§	coulomb/kilogram (C/kg)	2.579 760 X E -4
shake	second (s)	1.000 000 X E -8
slug	kilogram (kg)	1.459 390 X E -1
torr (mm Hg, 0° C)	kilo pascal (kPa)	1.333 22 X E -1

\*The gray (Gy) is the accepted SI unit equivalent to the energy imparted by ionizing radiation to a mass and corresponds to one joule/kilogram.

†The becquerel (Bq) is the SI unit of radioactivity; 1 Bq = 1 event/s.

## SECTION 1 INTRODUCTION

### 1-1 GENERAL

The purpose of Contract Number NAS3-22668 was to support the development of capacitor designs intended for reliable operation in space at continuous duty ac service of two different frequencies; 10 kHz and 40 kHz. Initially, it was considered probable that two different capacitor designs would be needed, but the decision was made to adopt a single design for both frequencies, since the relatively low RMS voltage of 600 volts did not permit sufficient flexibility in the selection of dielectric materials. The available thickness values of dielectric materials established a capacitor minimum size which was considered capable of performing well at the highest frequency specified. This report presents a description of the development activity from the original concept of the main problems to be solved, the parametric evaluation of the available dielectric materials, the electrical tests conducted on the discrete materials, the selection of the most suitable dielectric solid and liquid, the design of the various elements of the capacitor itself, the thermal analysis of the design, the preparation of the specifications for the many manufacturing operations and the processing of the assembled capacitors, the electrical and mechanical acceptance tests, and the successful completion of the Vacuum Endurance Test program.

Where possible in this report, test data has been presented in graphical form, to display disparities of performance. The individual data from which the graphs are plotted was obtained on laboratory instruments specifically calibrated for use in this program.

### 1-2 TECHNICAL

Certain characteristics of the capacitor design to be developed could be predicted from the initial consideration of the performance specification. For example, the high frequency of the alternating voltage indicated that thermal considerations would be paramount in the design concept, due to the dielectric and resistive losses of even the best obtainable conductor and dielectric materials. Also, the hard vacuum of the space environment demanded a capacitor enclosure of superior seal characteristics, particularly if a liquid impregnant was employed. The capacitor must be capable of meeting the most stringent conditions of vibration, acceleration, and shock to withstand missile launching.

The capacitor manufacturing industry has made great strides in recent years in the improvement of ac capacitor efficiency. Experience with the power factor improvement capacitor designs was expected to be the most valuable for reason that capacitor losses have been steadily reduced as dielectric materials were improved, and as processing techniques were developed to take maximum advantage of material developments. There were a number of acceptable

dielectric materials, both solid and liquid, from which a choice could be made to best perform under the specified conditions.

There was little doubt that a capacitor design could be made to perform satisfactorily under the intended conditions of voltage, frequency, pressure and temperature. The problem of obtaining maximum energy-density under those conditions was to be solved during this development period. Rather than attempt to push every material capability to the maximum, and immediately establish a design with the ultimate energy density, but debatable performance reliability, it was decided to give proper allowances for practical tolerances and put the greatest emphasis on meeting the performance conditions with efficiency and reliability assured. However, it appeared to be likely that the energy-density of state-of-the-art 60 Hz capacitors could be significantly surpassed, despite the disadvantage of the relatively low voltage specified.

Alternating current (ac) components are customarily compared on the basis of the volt-ampere values associated with their conditions of use. Transformers, for example, are normally rated in VA, volt-amperes, or in KVA, to employ a term more closely related to the usual size of the component. Power factor correction capacitors, on the other hand, are more commonly considered in units of kVAR, kilovolt-amperes-reactive, although the same volt-ampere rating applies. In any case, the point to be made is that the energy-density of ac components should be compared on the basis of their power handling capability per unit weight or volume, rather than the energy storage density more aptly associated with direct current components; for example, joules per pound or joules per cubic inch.

The limiting factors involved with achieving maximum energy or power density are somewhat different, although the differences are disappearing as further improvements in the quality of dielectric materials are made. The energy-density of direct current capacitors is limited by the dielectric stress value supported by the dielectric system, an exponential factor, combined with the dielectric constant of that system, a linear factor. For many years the limiting factor of ac capacitors was the thermal limit established by the dielectric losses in the dielectric system. However, the great improvements in the quality of plastic films used as dielectric solids has shifted the emphasis away from strictly thermal considerations to ac dielectric strength, and the various means of limiting corona - partial discharges - in the dielectric elements of the capacitors. As the frequency of application increases the thermal limits are again dominant, although the frequency coefficient of CIV (corona inception voltage) is important as well. However, there is a greater empirical basis for predicting thermal performance of a capacitor than there is valid reference for determining the effect on CIV from frequency.

The technical objectives for the capacitor development program became quite clear:

1. Design an enclosure for the capacitor which was inherently rugged in concept, to withstand the physical abuse associated with space vehicles.
2. Select a dielectric system with maximum dielectric strength, minimum dielectric loss at supersonic frequencies, flat temperature coeffi-

cients of dielectric loss and dielectric constant, and thermal stability over a temperature range from  $-40^{\circ}\text{C}$  to  $125^{\circ}\text{C}$ .

3. Design the active capacitor elements to assure freedom from internal partial discharges at the maximum limit of operating conditions. This consideration was vital in obtaining reliability and long life.
4. Provide a design for the assembly of capacitive pads and current conductors which directed the internally generated heat to the thermal plate as efficiently as possible.
5. Devise material inspection and manufacturing procedures to minimize the effects of tolerances of material and processing, and maximize the reliability of the finished capacitors.
6. Specify process control measurements and tests to weed out the inevitable mavericks during manufacture.
7. Prepare specifications for acceptance tests which would eliminate subnormal capacitors and establish a data base for performance prediction.
8. Obtain sufficient data from the Vacuum Endurance Test series to confirm the design performance of the capacitors, and to provide a benchmark for subsequent capacitor development.

SECTION 2  
TASK I - ANALYSIS - DESCRIPTION OF MATERIALS

Reference is made to Table 2-1 - Candidate Dielectric Materials. All materials seriously considered for use in this program are listed in this table.

The primary consideration in the selection of a capacitor dielectric system is normally given to the solid dielectric material, since the characteristics of the solid determine the performance quality and reliability, and the greatest dielectric stress appears across the solid material in service. The life of the capacitor usually is determined by the dielectric strength and thermal stability of the solid material.

For this particular application, the most important properties of a solid dielectric are considered to be: dielectric loss; for reason that the frequency of ac operation and the environment in space direct attention to the thermal problems likely to be encountered. Dielectric strength; because the life will likely depend on the resistance of the dielectric to the deterioration from partial discharges in the active volume and at the high-stress edges of the pad conductors. Physical factors of density, temperature resistance, tensile strength, and tear strength are considered, but are of lesser importance.

To produce a reliable and efficient high frequency ac capacitor, the designer must choose a dielectric system which will be virtually free of partial electrical discharges, as the ultimate failure mechanism will likely be dielectric deterioration from the local thermal degradation of corona in the capacitor elements. The primary concern is the reliability and service integrity of the capacitor. Secondary importance is assigned to considerations of energy density and to efficiency in operation, other than as efficiency affects life. Finally, in the case of the current contract, the cost and availability of the dielectric material is considered.

Inevitably, personal experience enters into the choice of materials. The cold, hard facts of the material data sheet play an important part in the selection, but many very important factors cannot be presented in an individual listing of physical and electrical characteristics. the most important empirically derived factor is the compatibility of materials, since it is often the case that one adds two and two and the result turns out to be five or, possibly, three. If it is deemed likely that the performance goals can be achieved by the choice of materials whose characteristics are familiar to the designer as the result of empirically derived data, then a theoretical optimum combination may not be chosen immediately, if hard performance data is not in hand. However, all materials listed in Table 2-1 were carefully examined before a choice was made.

TABLE 2-1  
CANDIDATE DIELECTRIC MATERIALS

---

1.0 SOLIDS

- 1.1 Paper - Kraft Capacitor Tissue
- 1.2 Mylar - polyester
- 1.3 Kapton - polyimide
- 1.4 Polypropylene
- 1.5 Polycarbonate
- 1.6 Polysulfone
- 1.7 Teflon - FEP
- 1.8 Polyvinylidene Fluoride - PVF

2.0 LIQUIDS

- 2.1 Mineral oil
- 2.2 Dimethyl silicone oil
- 2.3 PXE - diaryl alkane
- 2.4 MIPB - monoisopropyl biphenyl
- 2.5 DOP - dioctyl phthalate
- 2.6 Fluorinert - fluorinated hydrocarbon oil

3.0 GASES

- 3.1 Sulfur hexafluoride
  - 3.2 Freons
-

Although capacitor tissue paper has provided long and reliable service as a capacitor dielectric for many applications, it was judged inadequate for the high frequency ac service intended in this contract. The high frequency dielectric losses would create an immediate thermal problem, even at ten kilohertz, and the energy loss in a paper dielectric capacitor would seriously reduce the efficiency of the power conditioning system. For these reasons, a minimum amount of time was involved with the decision to remove capacitor tissue from consideration as a dielectric solid. Another consideration for space is the deterioration of paper when subjected to radiation.

Polyester film (Mylar), in this country deserved review for reasons having to do with its relatively high dielectric constant, which contributes directly to energy density, and for its high dielectric strength. Mylar has good temperature resistance, but suffers from a serious perturbation in the temperature coefficient curves of tan delta and dielectric constant around 100°C. This anomaly is serious to the point of causing thermal runaway and failure where high frequency ac operation is required. Despite the favorable radiation resistance characteristic of Mylar, and the obvious advantages of high dielectric strength and high dielectric constant, Mylar was eliminated from consideration. However, electrical measurements were made on impregnated Mylar dielectric capacitors to demonstrate the faults, which are not normally displayed in published data.

Polyimide film (Kapton) has undoubted advantages in regard to temperature resistance, and shares with Mylar the quality of relatively high dielectric constant. In addition, Kapton has high dielectric strength and excellent radiation resistance. Further, the surface and volume resistivity are exceptional; in fact, the surface resistivity detracts from the film's utility, since the static charge engendered by unrolling the film makes winding difficult, and dust particles are attracted to the surfaces. Kapton's tan delta is relatively high, the film density also does not lend itself to maximum energy density, and the concept developed of the optimum interfoil voltage for the windings handicapped Kapton, since this polyimide film is not available in consistent quality and gage control in the 9 to 10 micron thickness value required. In addition, but not most important at this point in time, if Kapton was available as required, the cost is several orders of magnitude greater than equally serviceable films.

Despite the relatively low dielectric constant of polypropylene film, and a restricted high temperature range, compared to many other candidate materials, polypropylene film was highly regarded as a candidate very early in the evaluation. The reason for this has to do with the great amount of very favorable experience the capacitor industry has with the material, and the excellent parameters of tan delta and dielectric strength offered by this film. Polypropylene capacitor film is manufactured by two different methods; the so-called "tenter" film, where superior electrical and physical characteristics result from biaxial orientation by mechanical means while the film is heated, and by "double bubble blown" methods, where the orientation is brought about by ballooning the film in two axes. Both methods provide acceptable film of high quality, but Maxwell's experience directs a preference for the "tenter" material. Another property of polypropylene film which endows the material with exceptional electrical performance is the manner in which polypropylene can perform when impregnated with the proper liquid material. A number of high



quality oils combine with polypropylene in a manner which dissuades partial discharges, thus prolonging life and maintaining high operating efficiency.

Polycarbonate film is another material with impressive credentials as a dielectric solid. The dielectric constant of polycarbonate is moderate; somewhat inferior to Mylar and Kapton, but 25 percent higher than polypropylene. However, the very important tan delta of polycarbonate is significantly higher than that of polypropylene, and the equally important dielectric strength is 30 percent lower. Data shows that there is little doubt that polycarbonate film would provide adequate performance as a high frequency dielectric material, but the electrical efficiency - the "Q" - of polycarbonate film is not the highest in the group of candidates.

Polysulfone film is famed for the superior thermal stability of electrical characteristics. With dielectric constant and dielectric loss characteristics similar to polycarbonate, polysulfone deserves serious consideration as the film to be used in high frequency ac capacitors. However, experience with polysulfone in such capacitors is minimal, availability is restricted to a very few sources, and the superior thermal properties of polysulfone are not required if other, lower loss, dielectrics are chosen. A low loss, inherently self-stabilizing dielectric, such as polypropylene, will provide superior overall performance.

Teflon (FEP) film is another high quality material which is manufactured in more than one manner. The highest quality thin film is produced by casting multilayers, but lower quality material is skived from a roll, with the attendant probability of voids and film defects. The electrical quality of Teflon is superb, the chemical stability is unsurpassed, and the slick surfaces make Teflon capacitors easy to wind. The high frequency loss tangent of Teflon is very low, and the temperature range of this material without peer. Except for an unfortunate susceptibility to damage from corona at all frequencies, and a high specific gravity - reducing energy density - Teflon presents fine credentials for high frequency dielectric application.

Polyvinylidene fluoride, called PVF and KF Polymer, is another material which, at first glance, appears to be the penultimate dielectric material. Unfortunately, despite the high but variable dielectric constant, and a reported value of dc dielectric strength comparable with the best of the other plastic films, PVDF is vulnerable in at least two of the important characteristics required for high frequency ac service. These two parameters are tan delta, in which PVDF is seriously deficient, and temperature stability of electrical characteristics - most importantly, dielectric constant and dielectric loss - when compared to any of the other candidates. For these reasons, PVDF was considered a candidate, but given rejection without thorough electrical testing, since the data sheets and experienced worked against it.

Although dielectric liquids or gases can be the sole dielectric material between the capacitor electrodes, both materials are more commonly used as impregnants in a dielectric system containing solid insulation. The function of the impregnant is to replace material of poor insulating properties; usually air and/or moisture. By the use of a good impregnating material it is possible to suppress partial electrical discharges and dramatically extend the useful life of the capacitor. For a given life the energy density can be significant-

ly increased, as a result of increases in dielectric stress possible by virtue of the suppression of corona.

Voltage stress upon a complex insulator divides in proportion to the impedance of each constituent. A dielectric system charged by a dc voltage has the individual stress values determined by the insulation resistance; the higher a value of insulation resistance the greater the voltage. The dielectric stress imposed on the elements of a complex dielectric system subjected to ac voltages is determined by the dielectric constant of the individual materials. Algorithms for determining ac dielectric stress in systems involving two or three different materials are shown below. For two materials:

$$SK_1 = \frac{V}{\frac{K_1}{K_2} t_2 + t_1} \qquad SK_2 = \frac{V}{\frac{K_2}{K_1} t_1 + t_2}$$

and for three materials:

$$SK_1 = \frac{K_2 K_3 V}{Q} \qquad SK_2 = \frac{K_1 K_3 V}{Q} \qquad SK_3 = \frac{K_1 K_2 V}{Q}$$

$$\text{and } Q = (K_2 K_3 t_1) + (K_1 K_3 t_2) + (K_1 K_2 t_3)$$

where:

- SK<sub>1</sub> = Stress on first material, v/mil
- SK<sub>2</sub> = Stress on second material, v/mil
- SK<sub>3</sub> = Stress on third material, v/mil
- V = Applied voltage, volts
- K<sub>1</sub> = Dielectric constant of first material
- K<sub>2</sub> = Dielectric constant of second material
- K<sub>3</sub> = Dielectric constant of third material
- t<sub>1</sub> = Thickness of first material, mils
- t<sub>2</sub> = Thickness of second material, mils
- t<sub>3</sub> = Thickness of third material, mils

To obtain a balanced stress across each constituent material in a dielectric system it is helpful to have the dielectric constant values somewhere close to the same. Individual characteristics of a number of dielectric impregnants are set forth below, in the order shown in Table 2-1.

Mineral oil is defined as any liquid petroleum product whose viscosity is in the range commonly called oils. The mineral oil product considered here, and generally used for the impregnation of capacitor dielectrics, is a highly refined oil with virtually all moisture removed. It is a capacitor grade oil, normally superior in electrical performance to what is normally called "transformer oil," and is subject to controls regarding its quality to a much greater degree. These factors are reflected in the cost, as one can imagine.

Mineral oil is not distinguished by dramatic superiority in any particular characteristic over the impregnants, but is a journeyman type of material,

giving stable, reliable performance over a wide temperature range, and being compatible with most solid dielectrics. Stability of characteristics at high temperature can be improved by the addition of suitable antioxidants, and the addition of chloride scavengers can prolong the life of the capacitor. Mineral oil is available in a range of viscosity values to suit most applications.

Capacitor grade silicone oils have a number of properties which make this liquid an exceptional dielectric impregnant. The most notable of the characteristics is the maintenance of a narrow viscosity spread over a wide temperature range. In addition, the available low viscosity silicones are excellent for impregnating plastic films. Silicone oil has little affinity for moisture. The dielectric constant value makes silicone oil mate well with plastic films, such as Mylar and Kapton, and reduces the stress on the oil when combined with the lower dielectric constant films.

PXE is yet another of the many dielectric liquids which have been found useful as capacitor impregnants. This oil is found to exert less solvent action on polypropylene film than other impregnants, while exhibiting a significant resistance to partial discharges. PXE has performed well in high frequency capacitors pulsed at high repetition rates for very long lifetimes, and is compatible with all capacitor films.

Monoisopropyl biphenyl (MIPB) is a special liquid whose radiation resistance makes it useful in space applications, but is also an excellent capacitor impregnant for plastic film dielectric systems. With polypropylene its corona resistance is unsurpassed, and its high frequency tan delta and DK match the film for proper distribution of dielectric stress.

Elimination of the PCB capacitor impregnants from lists of approved electrical materials created a critical need for an acceptable substitute. DOP has been adopted, and is being used by a number of capacitor suppliers, as an adequate replacement for PCB, but is considered a lesser material for several reasons. The most important deficiency is that DOPs have a much lower flashpoint and a clearly established firepoint, both anathemic for ac applications. However, DOP impregnants are being successfully used in combination with plastic films, and the much higher dielectric constant value of this oil can contribute to long life and higher energy density, so DOP was included in the list of candidates.

Fluorinated liquids possess properties which demand consideration where high frequency operation in a severe environment is contemplated. Among the many liquids of this type can be found one whose physical and electrical properties are suitable in almost every application. A low viscosity fluorinated fluid with good heat transfer characteristics would mate well with plastic films because the low surface tension facilitates impregnation and the loss tangent of the oil is properly minimal. The low dielectric constant and high specific gravity are negative factors, however, and Maxwell lacks any experience with this class of material in long life capacitors.

The electronegative gases have obvious attractions for impregnation of the components where the weight of liquids is counterproductive. In addition, both sulfur hexafluoride and freon have the property of self healing damage from partial discharges. However, gases must be used at several atmospheres pressure to approach the dielectric strength of liquids, and heat transfer - a pri-

mary concern - is lacking in gaseous environment. also, in the event of voltage arc-over in a fluorinated gas the byproducts are corrosive, particularly if any moisture is present. For these reasons, plus the fact that Maxwell is widely experienced in the use of electronegative gases in high power switches, but lacking in experience with such gases as capacitor impregnants, it was decided to list the gases as candidates, but choose an impregnant from the available liquids.

## 2-1 TASK I - ANALYSIS - TESTS OF MATERIALS

It was noted earlier in this report that the qualities of low tan delta and high dielectric strength were paramount for superior performance of dielectric materials to be chosen for the high frequency capacitors being developed. Information of this nature is available directly from the producers of the material, but is limited in regard to the conditions for which it is presented. The capacitor must operate over a relatively wide temperature range; at least from -40 to +125°C, and over a frequency range from 10 kHz to 40 kHz. Stability of capacitance is another property important to the function of the capacitor, but hard data covering temperature and frequency coefficients of capacitance, tan delta and dielectric strength are not available. No equipment was available to determine frequency coefficient of dielectric strength, so this data is not presented, but temperature and frequency coefficient of capacitance and tan delta is presented in Tables 2-2, 2-3 and 2-4, and Figures 2-1 through 2-7.

It will serve to help the readers' analysis of the test data if it is noted that there are accepted standards for the temperature stability of parameters such as capacitance and dissipation factor (tan delta x 100 - stated in percent), although frequency coefficient is seldom considered. Such standards are not used as performance boundaries in this analysis, but are kept in mind as outer limits of critical usefulness for similar components. For example; +/- 1000 ppm/°C is a common limit for capacitance change with temperature. With the exception of Mylar, which changes beyond this limit at a temperature near 100°C, none of the tested candidate materials approaches these limits. A factor not considered when commercial limits were established, but important for a satisfactory performance of the high frequency ac capacitor being developed, is that a reasonable negative temperature coefficient of capacitance will assist in self-stabilization of temperature during operation, as long as the capacitance loss at high temperature is not excessive.

The final overall evaluation of the candidate solid dielectric materials resulted in a choice based on a system of performance rating where each factor was given a quality rating of 0 to 10, and factors were classed as minor or major, doubling the rating for major parameters. The cumulative value obtained for each material was used to classify the materials. This rating plan was used on six of the candidates, the other candidates having been eliminated for reasons rendering them unsuitable.

Polypropylene film was chosen as the superior dielectric solid material by a significant margin, although the temperature coefficient of capacitance was greater than polysulfone. Even so, the total decrease in capacitance recorded at 125°C was 3 percent, but 0.8 percent at 75°C, where the capacitor will likely operate. The material chosen is a surface modified tenter film of dependable quality.

TABLE 2-2  
SAMPLE INFORMATION

SAMPLE NO.	DESCRIPTION
1	Mylar, dry, 2 x 92 ga. tape wrapped
2	Polycarbonate, dry, 2 x 100 ga. tape wrapped
3	Kapton, dry, 2 x 100 ga. tape wrapped
4	Polypropylene, dry, 2 x 100 ga. tape wrapped
5	Polysulfone, dry, 2 x 100 ga. tape wrapped

TABLE 2-3  
TEMPERATURE/FREQUENCY COEFFICIENT OF CAPACITANCE

		GROUP 1	GROUP 2	GROUP 3	GROUP 4	GROUP 5
1 kHz	75 C	+ 710	+39	+43	- 65	-35
	125 C	+2810	-38	-20	-238	-12
10 kHz	75 C	+ 878	+66	+62	- 64	-33
	125 C	+1282	-28	-31	-260	-25
40 kHz	75 C	+ 997	+76	+97	- 70	-40
	125 C	+1250	-19	-15	-263	-30

NOTE: All coefficients are given in ppm/deg. C. Values are averages of three samples.

TABLE 2-4  
 TEMPERATURE/FREQUENCY COEFFICIENT OF D.F.

LOT NO.	FREQUENCY			
	1 kHz	10 kHz	40 kHz	
25 C	1	.483	.93	1.19
	2	.12	.23	.34
	3	.18	.38	.58
	4	.04	.04	.06
	5	.1	.055	.225
75 C	1	.173	.30	.54
	2	.067	.09	.11
	3	.20	.19	.26
	4	.024	.03	.05
	5	.1	.11	.14
125 C	1	1.35	1.3	1.22
	2	.09	.066	.1
	3	.4	.25	.22
	4	.077	.03	.044
	5	.30	.15	.17

NOTE: Values of D.F. are given in percent (%)

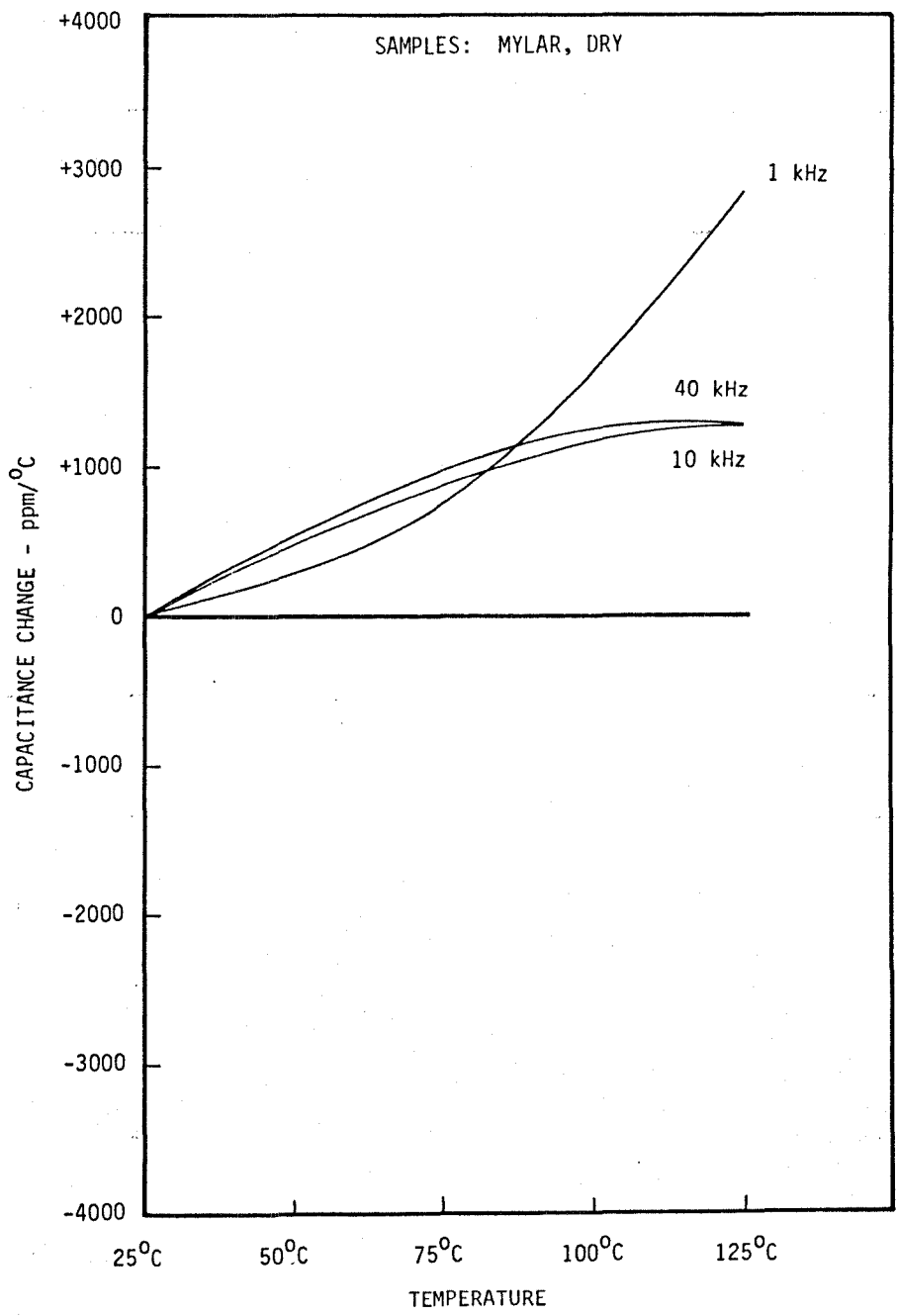

MLI81-0434

Figure 2-1. Temperature coefficient of capacitance - Lot #1

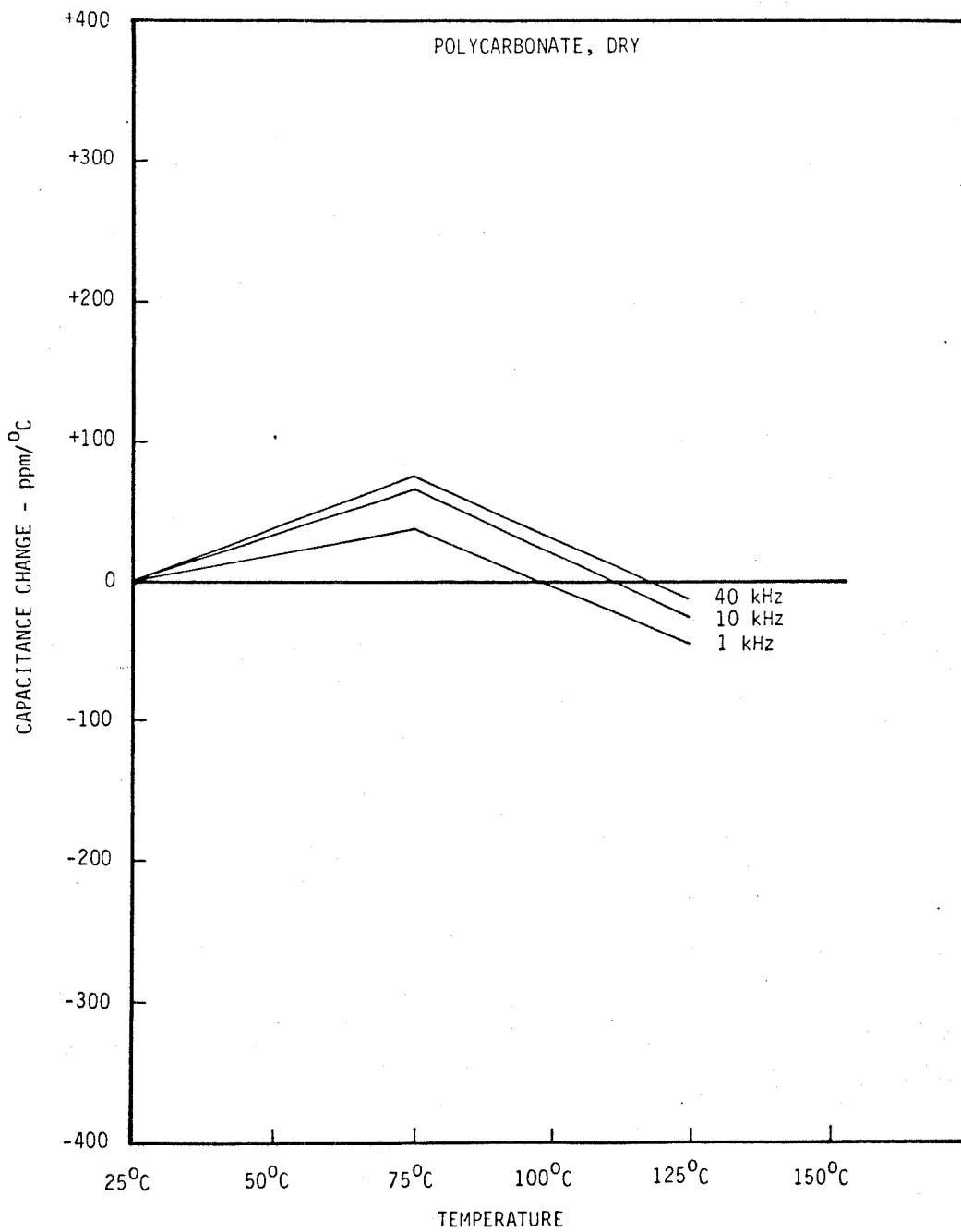

MLI81-0435

Figure 2-2. Temperature coefficient of capacitance - Lot #2



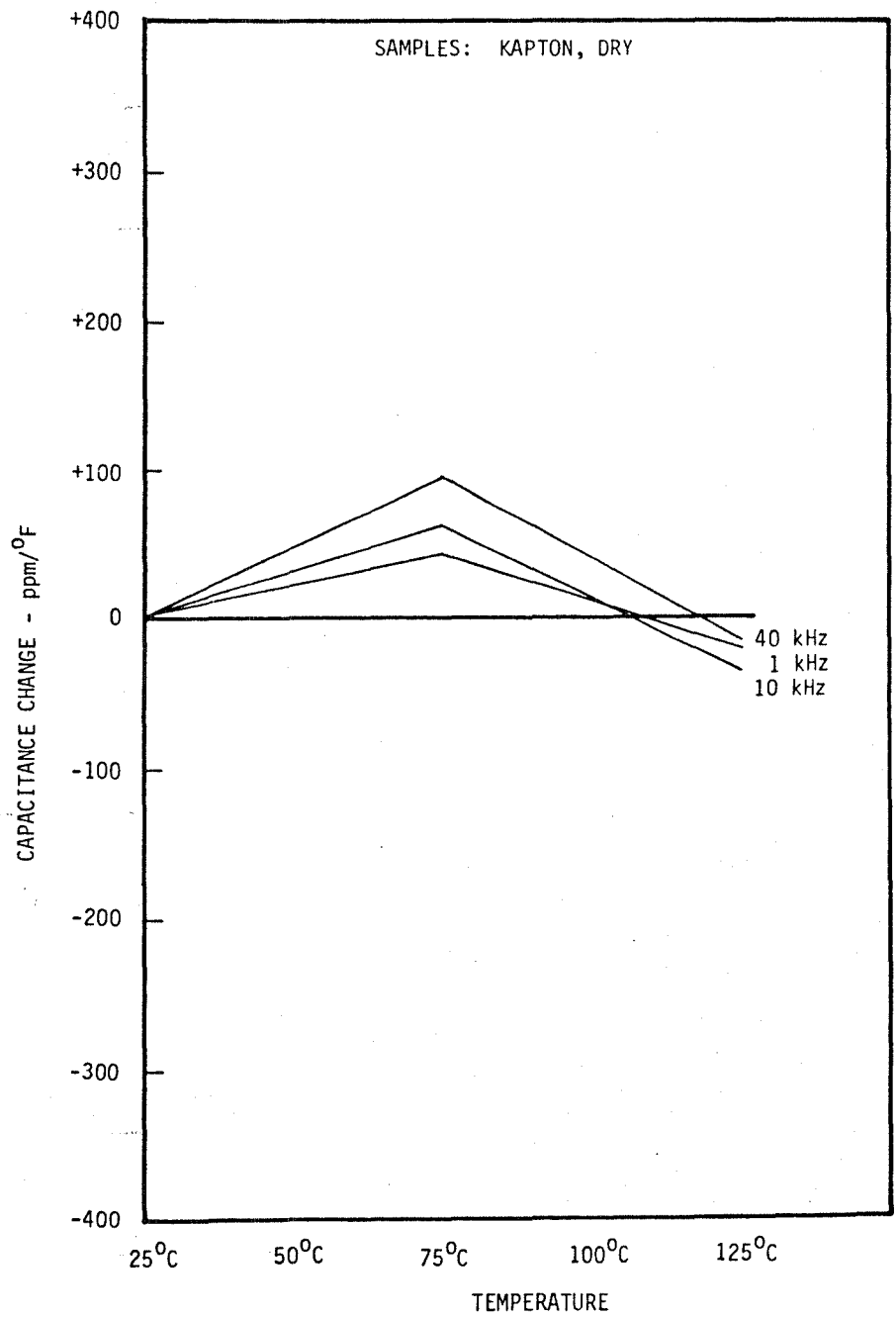

MLI81-0436

Figure 2-3. Temperature coefficient of capacitance - Lot #3

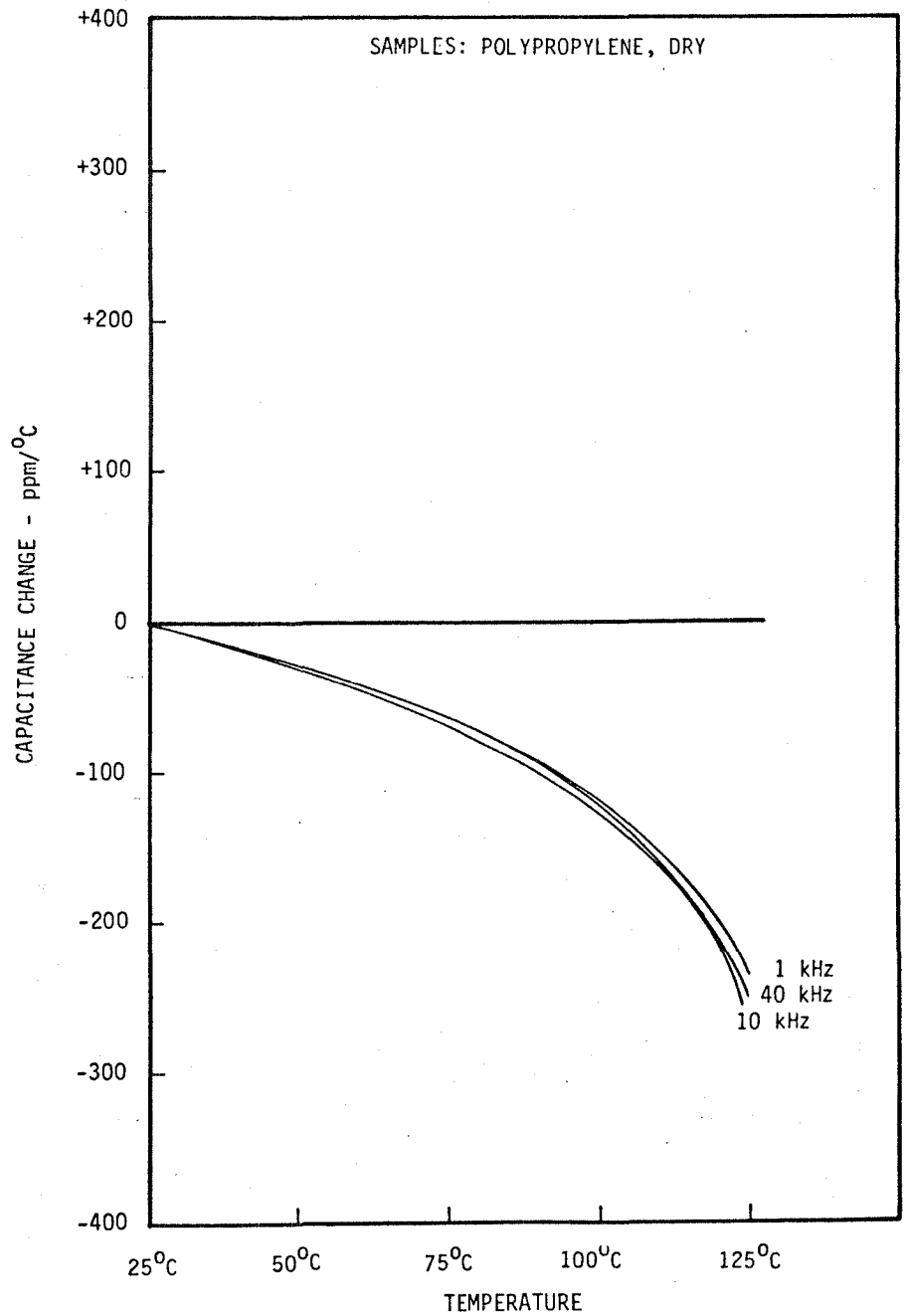

MLI81-0437

Figure 2-4. Temperature coefficient of capacitance - Lot #4

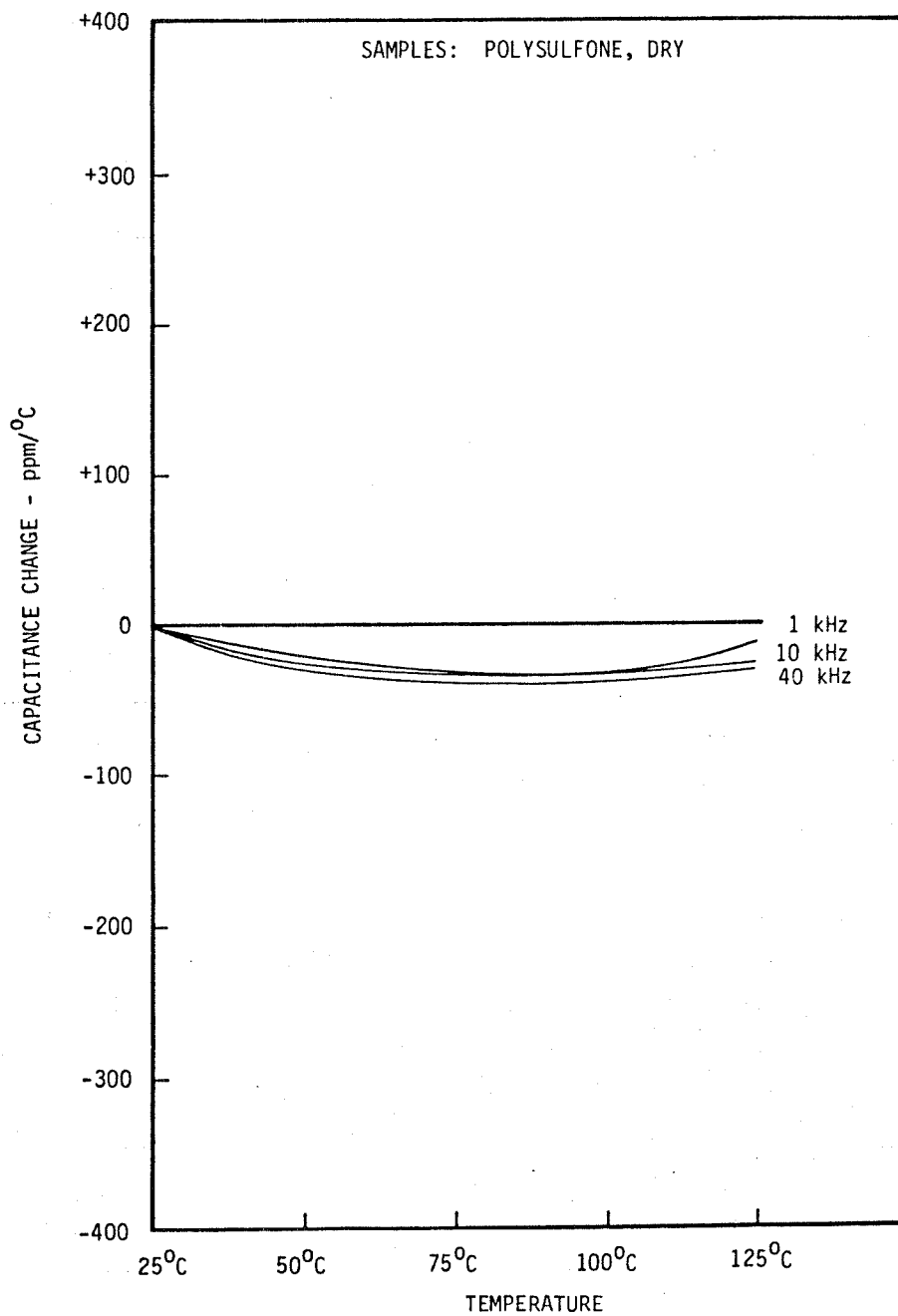

MLI81-0438

Figure 2-5. Temperature coefficient of capacitance - Lot #5

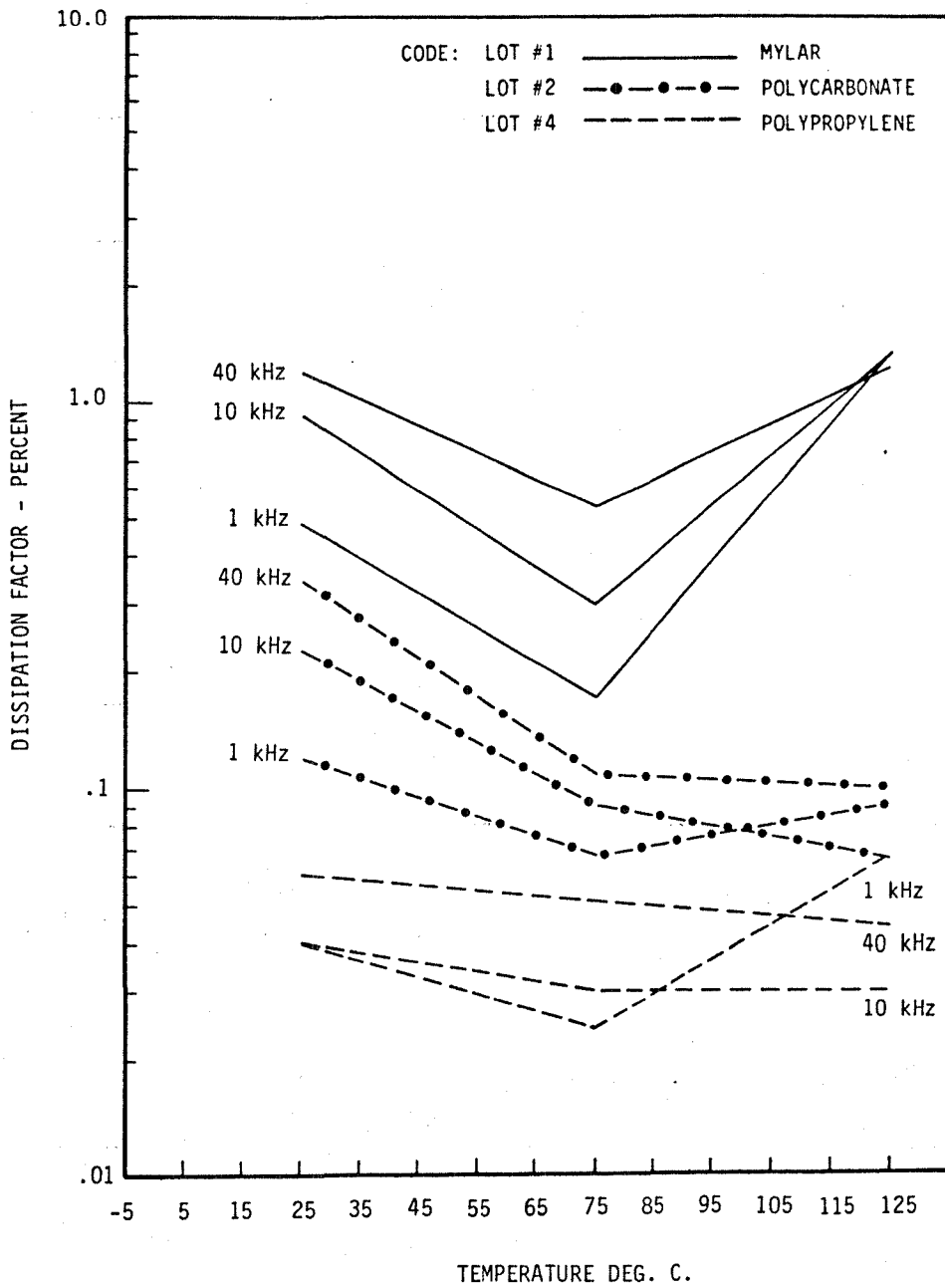

MLI81-0439

Figure 2-6. Temperature coefficient of dissipation factor

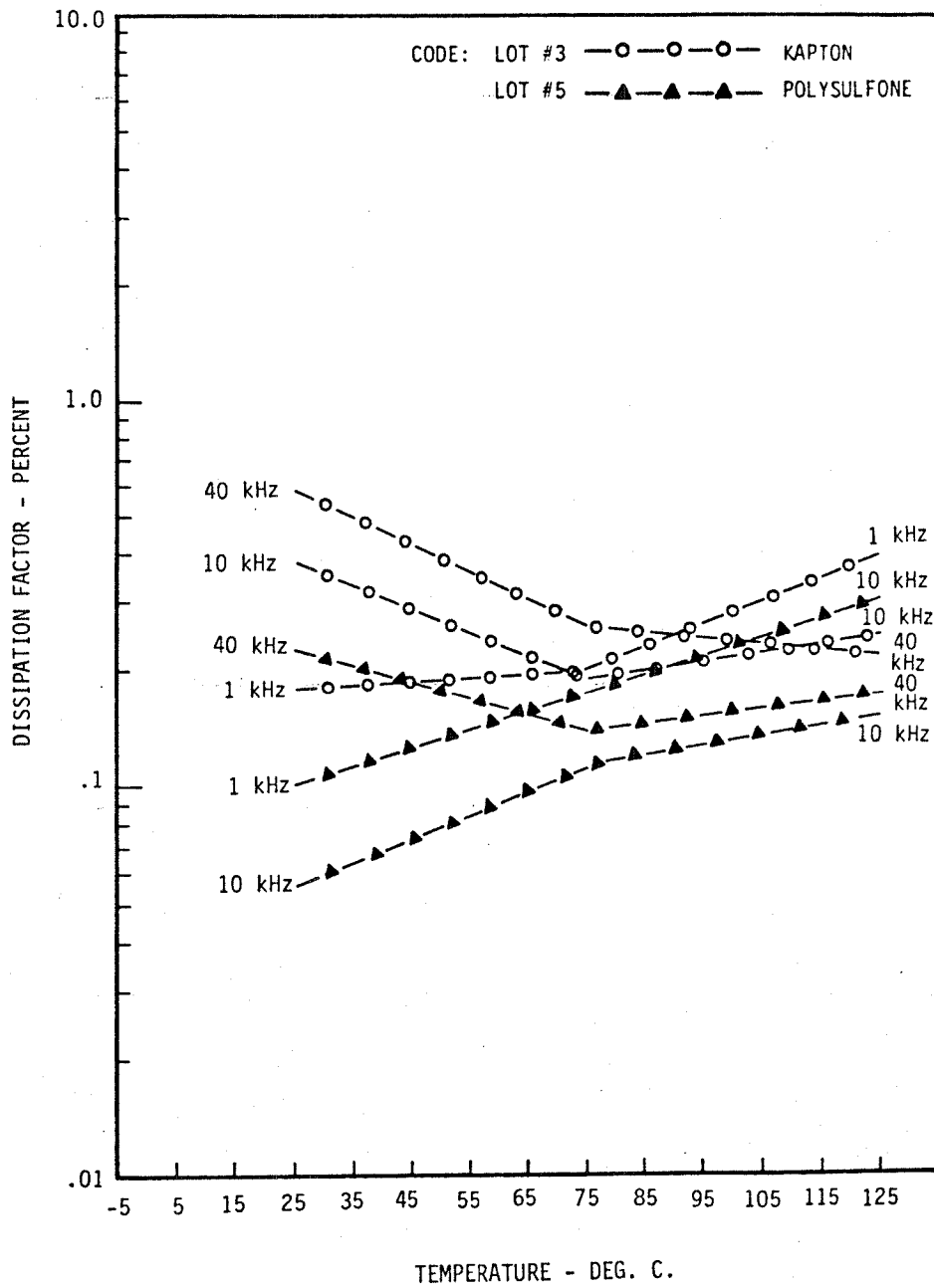

MLI81-0440

Figure 2-7. Temperature coefficient of dissipation factor

The choice of dielectric impregnant was not a simple one, since it is likely that at least five of the candidates will perform satisfactorily. Maxwell has good experience with dimethyl silicone oil, several varieties of mineral oil, PXE, and MIPB. We have not used fluorinated oils, for reasons to do with cost and processing, but the performance of Fluorinert has been reported on favorably by others. In any event, the qualities of dielectric strength, frequency and temperature stability, and proven radiation resistance tilted the choice to MIPB, and the results of life tests confirmed that choice. Both the polypropylene and MIPB are readily available.

SECTION 3  
TASK II - FINAL CAPACITOR DESIGN

Task II of the subject contract concerned the complete design of the capacitors to be produced under Task III for test during Task IV, the Vacuum Endurance portion of this contract. Description of the capacitor design and rationalization of the choice of materials and mechanical features is to be presented in sections; the complete capacitor being broken down into:

- The capacitive elements
- The conductor/element assembly
- The capacitor case and terminations
- The thermal elements of the design.

The analyses and tests of Task I engendered a clearly defined choice of dielectric film to be used for the capacitive elements. The conductor material of best performance was aluminum foil, highly purified grade, a material in normal everyday use in the capacitor industry. The dielectric impregnant choice had not been made at the time the request for approval of the Task I activity was solicited. This decision has been made, and either of two candidates can be a good choice. Additional information regarding the impregnant will be included later in this report.

### 3-1 THE CAPACITIVE ELEMENTS

In order to reduce the interfoil voltage of each element to a value which would provide the highest degree of performance reliability, but could still be efficiently accommodated by thickness values of available dielectric materials, each capacitor element - or pad - is designed with two series capacitor sections. To decrease the voltage yet further, two elements are then connected in series, thus reducing the ac voltage to a value of 150 V rms, at which point it is expected there will be no partial discharges at the full capacitor operating voltage of 600 V rms plus 600 V dc bias.

The formidable RMS current consistent with operating at maximum applied voltage and maximum frequency is to be dealt with by paralleling two series connected element assemblies, thus dividing the current, and reducing the 125 A to 62.5 A/pad, which can be handled by extended foil design of the elements. Figure 3-1 displays significant features of the "exposed foil" element design.

The maximum energy density of the capacitor would be obtained if a metallized dielectric film had been employed, rather than the film/foil design presented here. However, the resistance of the metallized conductor was of such a value to preclude choice of the latter for the high frequency applications. Thermal runaway conditions would certainly have prevailed very early in the life of the unit. Further, the significant value of RMS current would have quickly melted the metallized end spray connection of this type of capacitor.

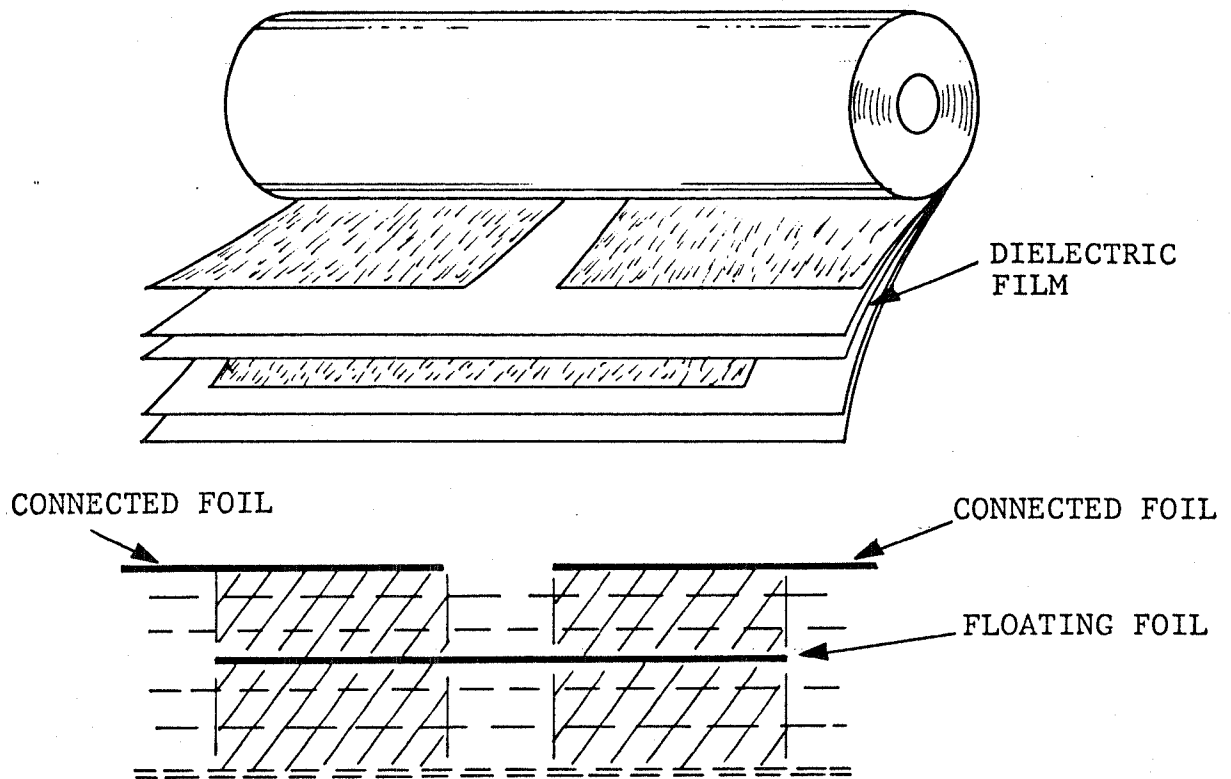

ML181-0451A

Figure 3-1. Capacitor element detailed



Another optimum - from the point of maximizing energy density - concept was considered, then rejected, based on early tests in the evaluation procedure. By lowering the interfoil voltage of a film/foil design below the characteristic corona inception voltage of a dry-unimpregnated capacitor it was reasonable to expect that the capacitor weight would be reduced by elimination of the oil and, additionally, all the problems involved with hermetic sealing a fully oil filled container in a space environment would have been eliminated. This sterling thought may still prove practical, but the safety factor under possible transient voltage conditions has been considered insufficient for the initial version of the capacitor. The oil-free design would also present a challenge in regard to heat elimination to the temperature plate.

The impregnant chosen is mono-isopropyl biphenyl (MIPB) because of its extreme resistance to gamma irradiation, and because it provides the low dielectric loss, the high corona resistance required, the good absorption in polypropylene film and very good wetting characteristics. This oil complements polypropylene very well indeed, and should be an excellent choice.

Yet another design consideration in the process of elimination was the choice between laid-in tab and exposed foil element design. The magnitude and the RMS current and the requirement for the ultimate Q of the capacitor quickly threw the selection to exposed foil. The foil-to-tab contact resistance, even with multi-tab design, was sufficient to guarantee early burn-thru at those points if laid-in tab design was adopted. In addition, the electrical resistance of the foils of the laid-in tab elements appears to be higher than that of exposed foil by more than one order of magnitude.

Since it is readily evident that a capacitor of maximum Q (minimum loss) is required for the application, nothing but the lowest loss dielectric material must appear in the electrical field. Such being the case, cellulose must be eliminated from the dielectric system, because of the relatively high dissipation factor, and an all-film design must be employed. A constraint of this nature involves yet another decision; because of the presence of pinholes and conducting particles normally present in plastic films, it is almost mandatory that multiple layers of film be used between foils, and impregnation between layers is a classic problem for capacitor engineers. To properly and practically consummate this task demands a relatively loose winding but, equally important, the film factor (space between film and foil layers) must be reasonably uniform. This condition is virtually impossible to achieve if a winding - or pad - is wound on a cylindrical arbor and flattened when assembled. Winding on a flat arbor is an obvious solution, but is, unfortunately, much easier to contemplate than to accomplish. It is far more practical to wind with uniform tension on a cylindrical arbor and retain that form in the finished design.

Despite the many disadvantages of liquid impregnation, it transpires that the problems of such a choice must be dealt with, rather than cripple the capacitor with the frailties of gaseous or solid impregnants. Gas impregnation appears to be ideal from the aspects of ease of fully impregnating the elements, and a proper electronegative gas at three atmospheres pressure is supposed to have comparable dielectric strength to an average transformer oil. For ac applications, however, equivalency is seldom found, and space vehicles traditionally abhor a component with high internal gas pressure. Solid impregnants have most of the disadvantages of gas, are normally the heaviest of all, and have none of the favorable characteristics of the liquids. Most solid

impregnants cavitate when they solidify or polymerize, and the result is the same corona inception values as those of atmospheric gas - very poor. If the solids are thermoplastic in nature they exhibit very low dielectric strength at the transition temperature. It appeared to us that adoption of liquid impregnation was clearly indicated, and further development should be in the direction of gas impregnation at one atmosphere pressure. A possibility for internal pressures in the hard vacuum area, to take advantage of Paschen's curve, is interesting to contemplate, as well.

### 3-2 THE CONDUCTOR/ELEMENT ASSEMBLY

The series-parallel assembly configuration of the capacitive elements was explained in the previous section. Figure 3-2 shows a single capacitor element, and displays one solder swage pattern. Figure 3-3 illustrates the capacitor element assembly. Although this type of assembly obviously leaves something to be desired in space utilization, the inefficiency is more apparent than real, and the design gains more than it loses. Mechanically, the element assembly must be inherently very stable, and must be extremely secure to withstand the vibration and shock associated with space vehicles. This element assembly will pass Class III vibration test, and will be safe from damage from acceleration and shock. Electrical integrity will be maintained over the service life stipulated for this component.

The assembly of four elements will be secured to the capacitor base in a layer of special epoxy resin which has the dual function of heat transfer from the bottom exposed foils directly to the capacitor base and then to the lower mounting bracket. The epoxy is identified as Emerson and Cuming Stycast 2850 KT, a material of exceptional thermal conductivity, low shrinkage, high temperature resistance and low temperature coefficient of expansion.

### 3-3 THE CAPACITOR CASE AND TERMINATION

Figure 3-4 illustrates the complete capacitor outline drawing. While not immediately apparent from the drawing, this unit is inherently very rugged, and the hermetic seal will be maintained over the operational life. The case material is 20 g 304L stainless steel, chosen for strength, stability, weldability, and to provide minimum eddy current losses at the maximum operating frequency. Both cover and base are of "re-entrant" configuration, to assure minimum heat damage to the interior materials during the welding operation after assembly. The only welding accomplished after assembly of the elements into the case is the weld around the periphery of the cover.

A modified bushing design is employed, for the purpose of - primarily - bringing a terminal (stud) of sufficient size through the bushing to handle the highest RMS current. Figure 3-5 and Figure 3-6 show the conventional bushing insulator configuration and the modified design adopted to expand the capability of this small bushing. By this means we have reduced the resistive losses of the terminals to a total of less than four watts under maximum operating conditions. A low profile bushing configuration would be even better, but such an insulator was not available at this time.

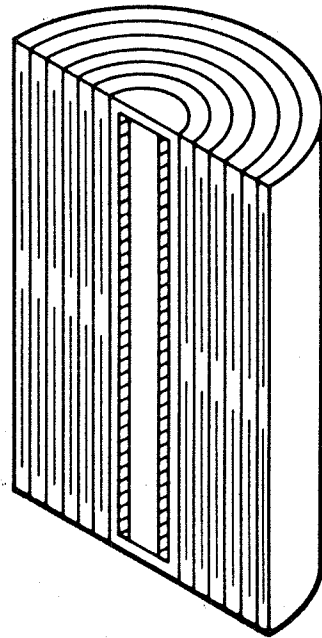
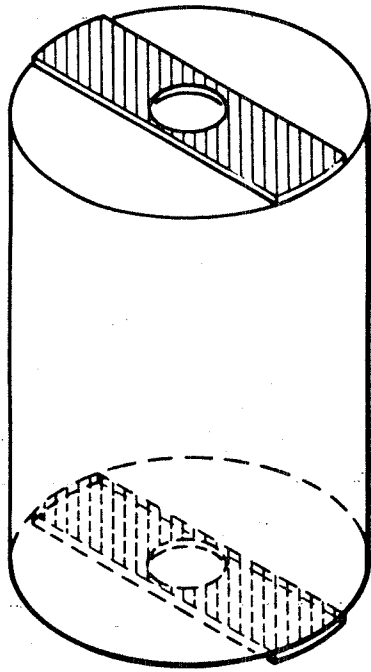

MLI81-0449A

Figure 3-2. Capacitor element

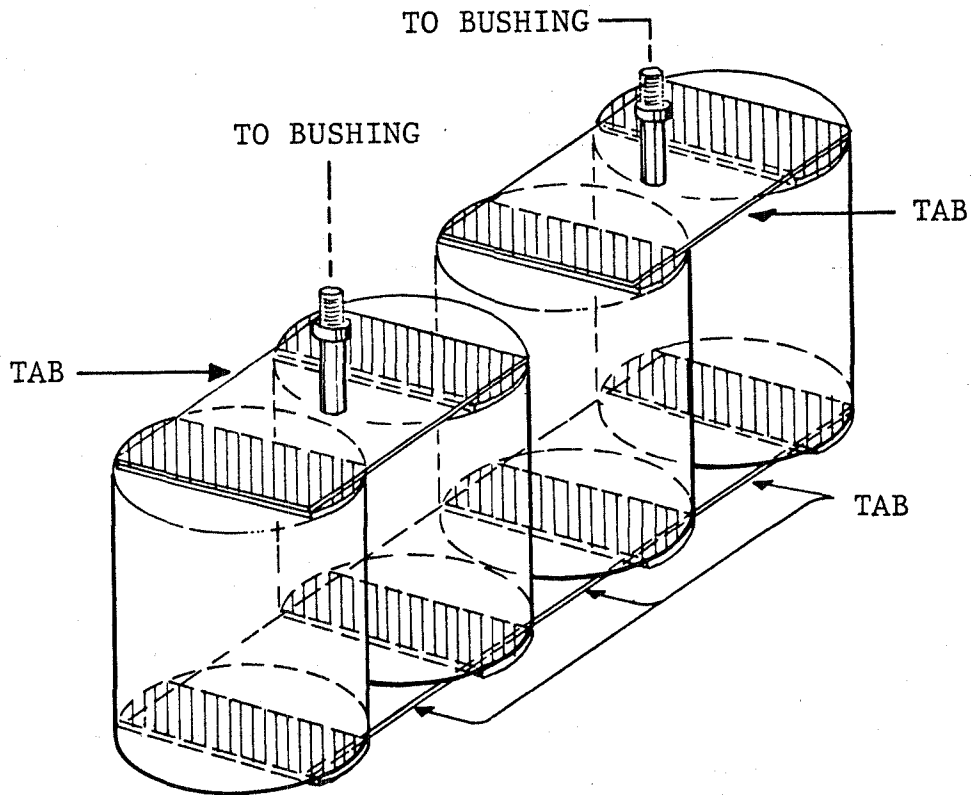

- SOLDER SWAGING IDENTICAL - TOP AND BOTTOM - ON EACH CAPACITIVE ELEMENT
- INITIAL SOLDER SWAGING TO EXTENDED FOILS ACCOMPLISHED WITH J22 SOLDER
- TINNED COPPER TABS SOFT SOLDERED TO SWAGED PATTERN WITH 60/40 T-L SOLDER
- ELEMENT CORE HOLES PLUGGED WITH POLYPROPYLENE RODS AFTER SOLDER SWAGING

MLI81-0450A

Figure 3-3. Capacitor element assembly

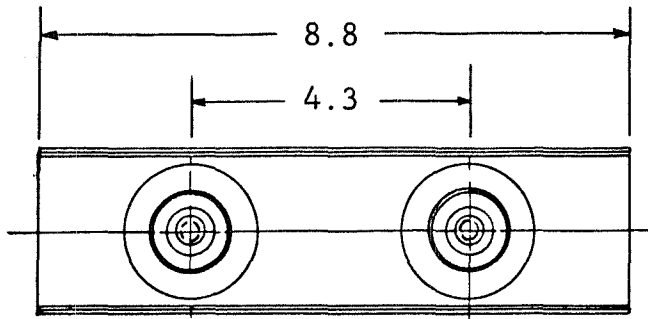

**CHARACTERISTICS**

VOLTAGE: 600 VRMS + 600 V DC  
 CAPACITANCE: 0.83 MFD. +/-10%  
 FREQUENCY: 40 kHz  
 DESIGN LOSS: <30 WATTS  
 TEMPERATURE: -40 C. TO +85 C.  
 RATED KVAR: 75

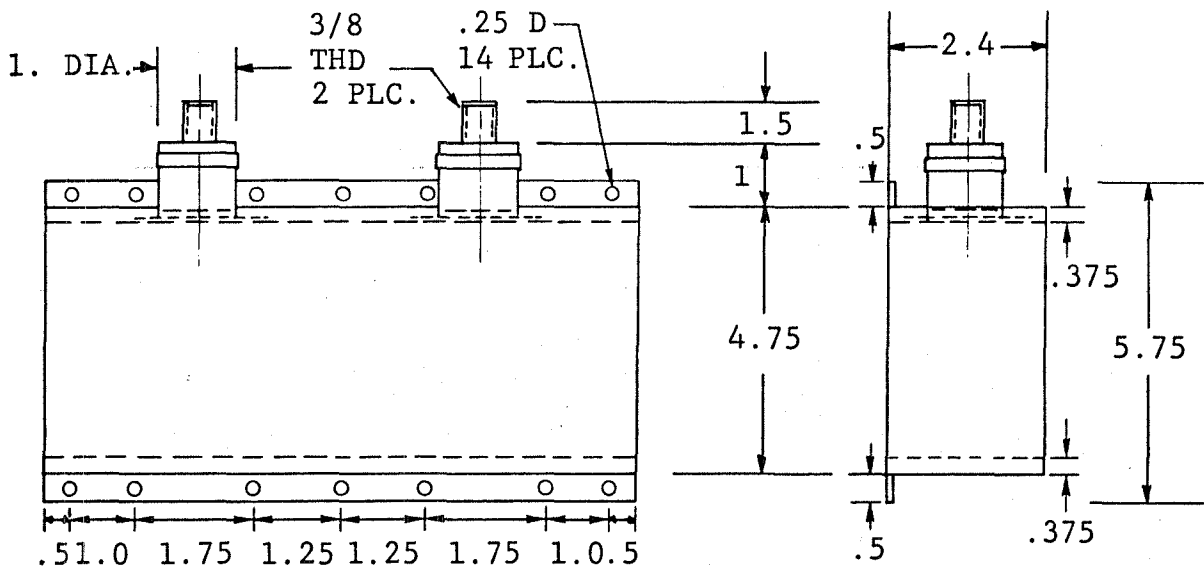

MLI81-0447B

Figure 3-4. 40 kHz capacitor outline

CONVENTIONAL

MODIFIED

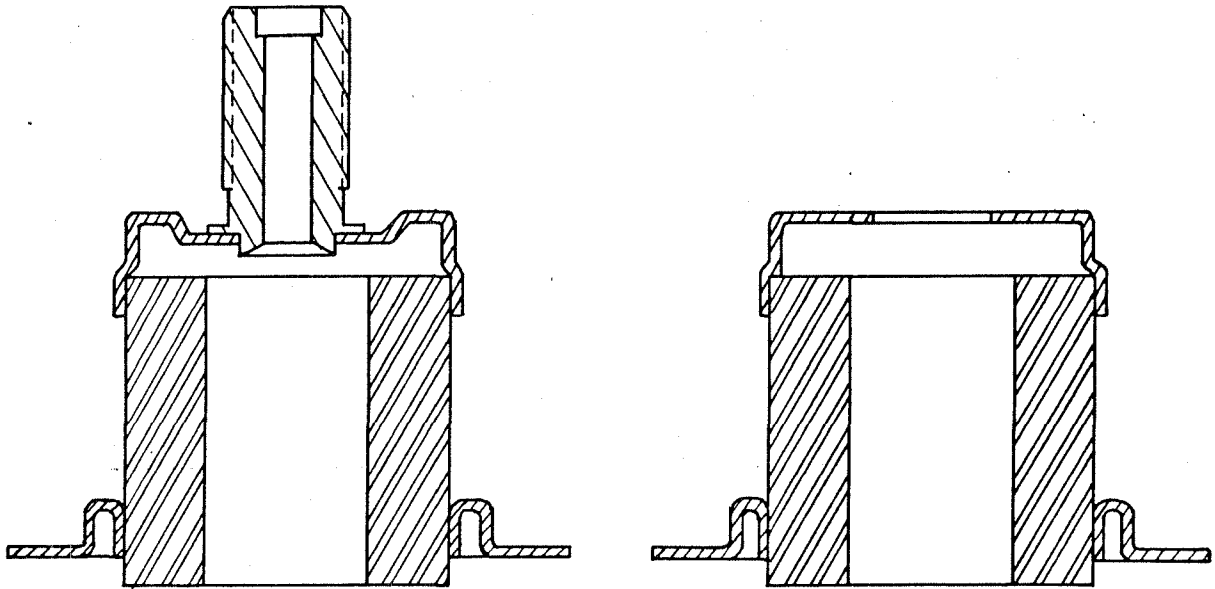

MLI81-0452A

Figure 3-5. Capacitor insulators

CONVENTIONAL

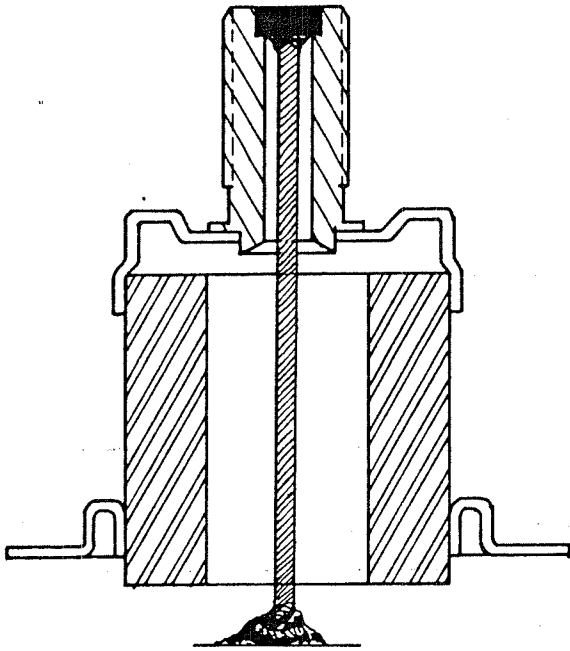

MODIFIED

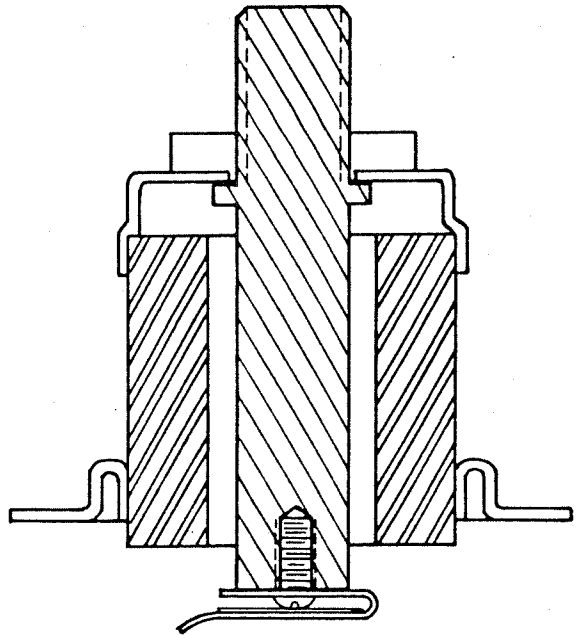

MLI81-0453A

Figure 3-6. Electrode/insulator assemblies

A similar layer of epoxy to that used internally to secure the elements is poured into the re-entrant cover, around the terminals and over the seal-off plug after the capacitor is fully impregnated and seal tested. This material helps transfer heat from the bushings to the mounting bracket and from the case to the lower mounting bracket; it also provides a redundant oil seal around the bushing flanges and over the seal-off plug.

#### 3-4 THE THERMAL ANALYSIS OF DESIGN

Under maximum conditions of operation the total heat loss in the capacitor is calculated to be about 21 w. Fifteen watts will be generated uniformly in the mass of the four elements, due to dielectric loss. The exposed foil design limits the resistive losses in the aluminum foil conductors of the four elements to a value less than 2 w. The two terminal studs will, in combination with the heavy copper tabs connecting the element assembly to the terminals, provide another 4 w. to the final total.

The heat generated in the individual elements will go to the foil extended ends via the foils themselves, and appear at the element connecting points at opposite ends of the elements. From these points the heat will be conducted to the can base and the cover by the connecting tabs at the top and the interior epoxy layer at the base of the capacitor. Heat will also be transported to the case surface (all six) by the impregnating oil, and will flow along the exterior surfaces to the temperature plate via the brackets as well as directly from one flat case surface.

Maxwell has little empirical knowledge regarding temperature rise of ac capacitors operated in a space environment against a temperature plate. However, the capacitor will operate reliably at a temperature far above a reasonable case temperature rise, and the dielectric system chosen for the design is inherently self stabilizing, since the temperature coefficient of dissipation factor is negative up to a temperature of 85°C, 20°C above that of the plate temperature.



## SECTION 4 CAPACITOR MANUFACTURING

In the manufacture of capacitors intended for extreme service duty, service expected to be beyond the present state of the art, it is necessary to apply measures normally not necessary in the production of conventional capacitors. The materials purchased all have tolerances on their dimensions and their characteristics, and the capacitor designer works within the known tolerances. When the materials are received in-house, inspection is conducted to the recognized tolerances and the material is accepted and used as received.

The severe duty requirements specified in the SOW of the contract demands superlative performance from all materials used in the capacitor. Although the characteristics of all materials specified are suitable for the service, it is to the best interests of all to enhance the performance if at all possible. This enhancement is not capable of making the material perform beyond its capability, but is intended to accommodate the predictable variations in characteristics which are present in all products we buy.

Each capacitor pad is cylinder wound with two conductors separated by the dielectric material. In actual fact, each pad contains two capacitors in parallel, and the winding machine setup includes the two conductors and two sets of dielectric materials. The capacitor will perform normally if both sets of dielectric materials are nominally the same, although variations in thickness exist between them due to the normal thickness tolerances in the material. In fact, there is always a difference in the two pad thickness values, and it transpires that we suffer if one pad contains dielectric materials on the low limit of the thickness tolerance, but there is no real benefit from the balancing of an extra thick pad in the parallel capacitor. To make best use of the material on hand, it is obvious that the effect of this variation must be minimized.

Each roll of dielectric material will be measured for thickness in the areas of active width, and the thickness variation over a significant length will be plotted by the thickness measuring instrument. In addition, randomly selected areas of the material in each roll will be weighed on a laboratory balance, and the average thickness determined in this way. In this manner, a thickness value will be assigned to each roll, and each winding machine setup will be made with the two dielectric thicknesses balanced to the maximum degree. This procedure will yield the best performance from the available materials.

In order to best impregnate an all-film capacitor pad it is advantageous to wind with as little tension as possible. In fact, the desired loose winding is very difficult to produce with a quality appearance and without wrinkles, even with careful tension control.

An important part of the capacitor manufacturing operation is the in-process inspection of each capacitor pad before assembly into the capacitor case. Since the pad - the capacitive element - has not yet been vacuum dried or vacuum impregnated, it is not electrically stressed to the maximum, but electrical evaluation is made to assure that each pad is a normal unit, as established from the previously determined characteristics, and from the statistics of the population, as defined by the measurements of the pads themselves. Figure 4-1 shows an element inserted into the fixture ready for electrical measurement. This fixture is designed to insert into measurement facilities with minimum effect on the element's electrical characteristics.

Each item of material will be hand cleaned and inspected, before sealing into a plastic bag. The material will be stored in this condition before assembly into the capacitor.

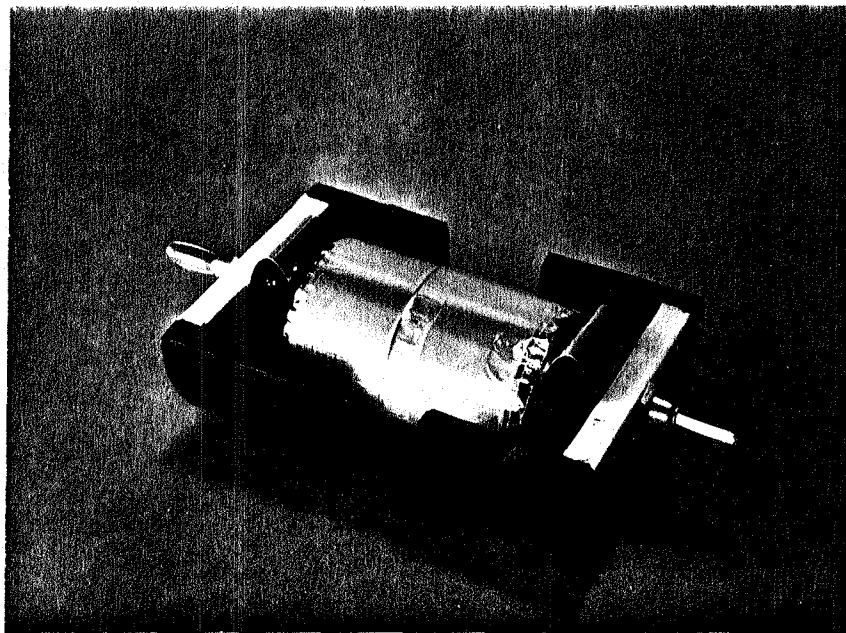

MLA-4314

Figure 4-1. Capacitor pad test fixture

## SECTION 5 CORONA MEASUREMENTS

It is considered worthwhile to explain Maxwell's concern with the values of CIV (Corona Inception Voltage) and CEV (Corona Extinction Voltage) on the capacitor windings (pads) to be installed in the capacitors being prepared for the Vacuum Endurance Test.

It is generally accepted that electrical failure of a capacitor operated on alternating current is preceded by increasing partial electrical discharges (corona) in the capacitive elements. The locally-generated extremely high temperatures result in deterioration of the insulating materials, both solid and liquid, and the gaseous by-products of this deterioration either remain in the area of high electrical stress or are dissolved in the impregnant. In either event, the result is progressive damage to the insulation, and the partial discharges increase to an avalanche condition, resulting in electrical failure.

If the CIV value measured on a given capacitor is at least twice the normal operating voltage, it is considered safe to assume that eventual capacitor failure, when it inevitably comes, must result from progressive electrochemical changes in the elements, and such a condition will normally occur beyond the design life of the unit.

The Corona Extinction Voltage (CEV) is the voltage value at which partial discharges no longer occur, after inception has been brought about. The CEV is usually determined by increasing the applied ac voltage until CIV is obtained, then lowering the applied voltage until corona is no longer detectable. The significance of CEV lies in the fact that an ac capacitor is subjected to electrical transient stresses during its life which are beyond the normal working stresses. If these transients are severe to the point that CIV is reached, no permanent harm will result if the CEV value is above the voltage applied after the transient condition is no longer present. For this reason, it is necessary that the CEV measured on the capacitor be greater than the normal operating voltage. However, it will be obvious that some safety factor must be present to allow for changes in capacitor characteristics over the operating life.

Model windings of the capacitor to be tested on the Vacuum Endurance Test were prepared and the CIV and CEV measured at 60 Hz with no impregnant and after vacuum drying and impregnation with monoisopropyl biphenyl. The rms voltage values are listed in Table 5-1. The pads were assembled in a circuit of two series elements to correspond exactly to the design of the test capacitor.

TABLE 5-1  
RMS VOLTAGE VALUES

DESCRIPTION	CIV	CEV
Dry pad assembly	1,400	1,250
Impregnated assemblies	3,200	2,800

We are not aware of any accurate measurements of frequency coefficient of corona performance of dielectric materials having been reported in the literature. However, it is possible to estimate this effect as a corollary to the work accomplished by the Signal Corps, many years ago, to evaluate the dielectric strength of then popular insulators as it was affected by frequency. A rough approximation of the effect of increasing the test frequency from 60 Hz to 40 kHz would be to decrease the 60 Hz value by 50 percent. It would appear that properly impregnated capacitors of the chosen design will have the necessary safety margins at the maximum operating frequency.

Figure 5-1 describes a circuit to evaluate the dc biasing of the 600 V rms, 40 kHz, voltage conditions on the corona starting and corona extinction voltages (CIV and CEV) of the capacitors produced on this contract. The voltmeter V2 was placed across the test capacitor to measure the applied ac 60 Hz voltage more accurately. The use of this meter was considered advisable for reason that the corona equipment is designed for voltage values up to 50,000 V rms, and the voltmeters lack accuracy at the 600 V rms to 3500 V rms range expected to encompass the CIV and CEV values of the capacitors.

C2 was used to block the dc from the ac meter, and it was necessary to employ a capacitor of very high insulation resistance for C2, and wait until C2 was fully charged, before applying the corona test voltage.

The procedure for evaluating the bias coefficient of CIV and CEV was as follows:

1. Using the diagram shown in Figure 5-1, turn the dc power supply ON, but set the voltage value at zero. Apply 60 Hz ac voltage to the test sample, continuously increasing ac voltage until minimum definite partial discharges are evident on the CRT. This voltage value is recorded as CIV. Slowly decrease applied voltage until no corona is evident on the elliptical display. The voltage value at this point is recorded as CEV. Turn ac to zero.
2. Increase dc voltage to 600 dc V and wait until C2 is fully charged, as evidenced by the decrease to zero of the voltage indicated on the meter across the test capacitor. When the voltage has dropped to zero, increase ac voltage slowly until the identical evidence of partial discharges appears on the CRT and record the ac voltage as CIV.

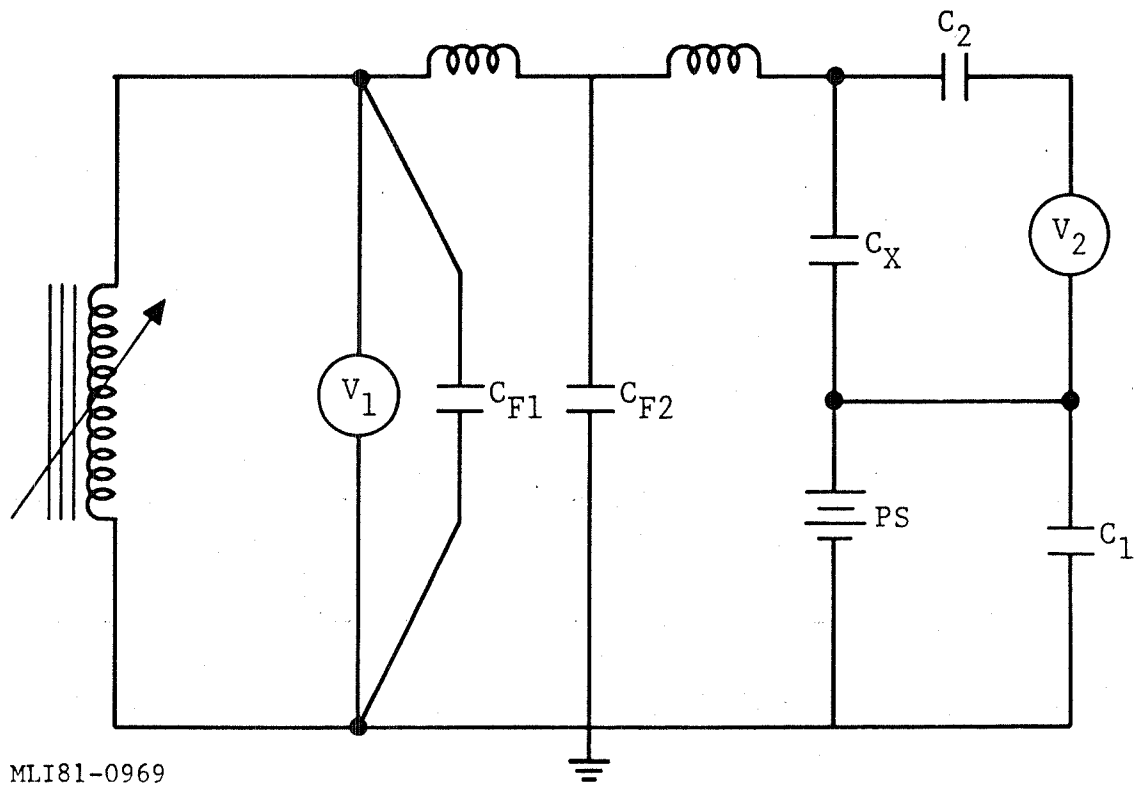

MLI81-0969

Figure 5-1. Circuit to evaluate dc biasing

Reduce the ac voltage until the corona disappears, then record this voltage value as CEV.

The procedure noted above was employed to measure CIV and CEV of several capacitors of identical element construction to the design of the capacitors to be tested. The results of the measurement are shown in Table 5-2. The results show little or no effect of the dc bias on CIV and CEV of the test capacitors within the accuracy of measurement.

TABLE 5-2  
RMS VOLTAGE VALUES WITH DC BIAS

CONDITION	CIV	CEV
No dc bias	3,200 V rms	2,800 V rms
600 V dc bias	3,150 V rms	2,800 V rms

## SECTION 6 ENDURANCE TESTING

The endurance testing for the program was to be as follows:

### 6-1 TEST PLAN

This test plan describes a "vacuum endurance" test to be performed on two separate test lots sequentially as dictated by available sub-contractor power facilities. The test capacitors shall be furnished by Maxwell Laboratories, Inc. The test facility shall be furnished by Industrial Electric Heating, the sub-contractor, and examined and approved by a representative of Maxwell Laboratories, Inc., prior to the start-up of the test. A representative of Maxwell Laboratories may observe the test operation at any time and may interrupt the test before completion of the scheduled period if the test specification is not satisfactorily met.

The sub-contractor shall conduct the life test procedures in accordance with the following test program specifications in a continuous manner unless either test is interrupted by malfunction of the test apparatus. In the case of equipment failure, the sub-contractor shall make every reasonable effort to repair or replace malfunctioning components of the test facility as expeditiously as possible, since such interruption will not be characteristic of the design operating conditions of the capacitor test samples.

### 6-2 TEST PROGRAM

A total of 24 capacitors shall be submitted by Maxwell Laboratories for the vacuum endurance test program. Two lots of 10 each shall be obtained by dividing a group of twenty capacitors in half in a random manner, then numbering individual samples in such a way that Nos. 1 through 10 shall be submitted to the test condition "A" and Nos. 11 through 20 shall be submitted to test condition "B". Test condition "B" will be conducted first, followed by test condition "A". The capacitors will be tested as in Figure 6-1. The remaining four identical capacitors supplied by Maxwell Laboratories shall be used only if required by circumstances of human error or accident to the test samples. All initial electrical measurements shall have been made and recorded by Maxwell Laboratories, but the sub-contractor shall be capable of measuring the characteristics of individual samples sufficiently to ensure that no sample is placed on the vacuum endurance test after damage in transit has occurred.

The following test conditions shall be maintained for each test condition, designated "A" and "B", for a period of 500 hours minimum, or until terminated by Maxwell Laboratories, whichever is sooner:



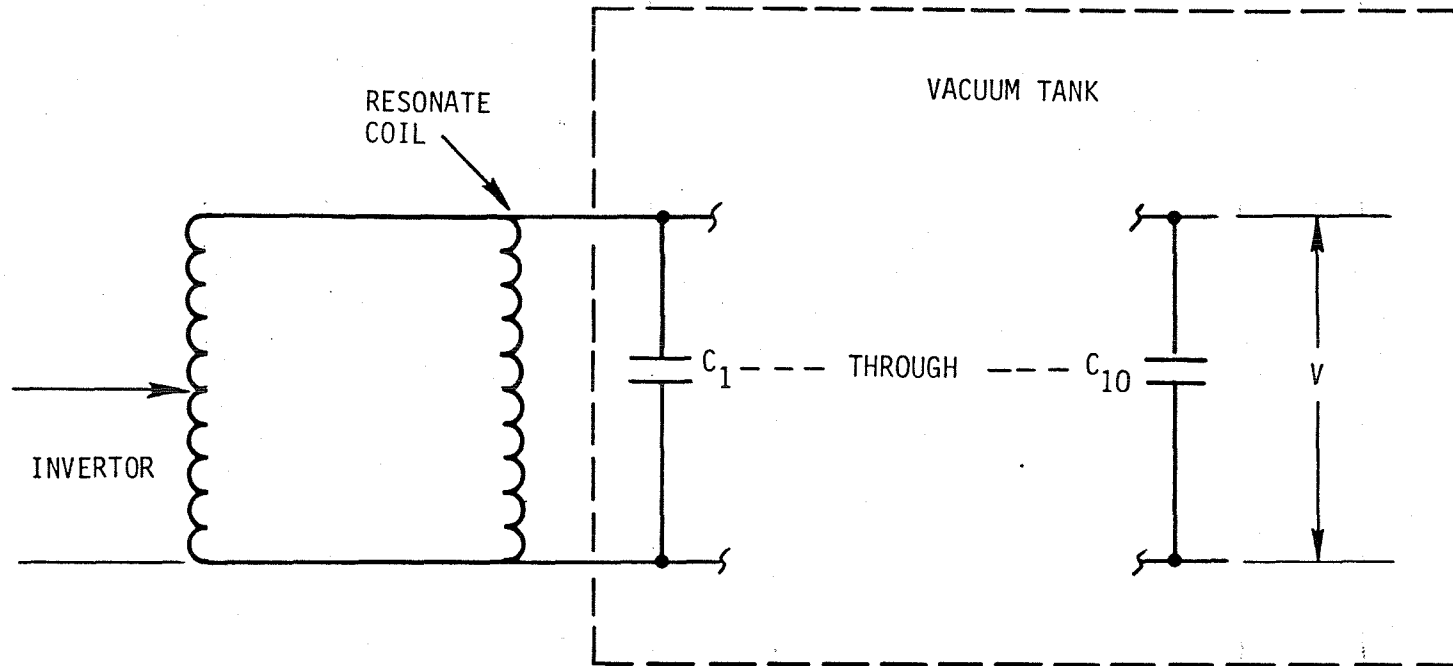

$V_A$  600 V ac 10 KHZ

$V_B$  600 V ac 40 KHZ      600 V dc BIAS

MLA-4304

$C_1$  THROUGH  $C_{10}$  = .83  $\mu$ F EACH

Figure 6-1. Vacuum endurance test diagram

	TEST CONDITION	
	<u>A</u>	<u>B</u>
Number of test samples	10	10
Temperature <u>+5°C</u>	25°C	25°C
Barometric pressure	<10 <sup>-3</sup> Torr	<10 <sup>-3</sup> Torr
Applied voltage <u>+ 2%</u>	600 V rms	600 V rms
Wave shape	sine wave	sine wave
Frequency <u>+ 1 kHz</u>	40 kHz	10 kHz
D.C. Bias <u>+ 2%</u>	600 V dc	zero
RMS current (sample <u>+ 5%</u> )	125 A	30 A

The two vacuum endurance tests shall be conducted with the samples mounted to a temperature plate held at a temperature of 60°C + 5°C (140°F + 7°F) by means of continuous water circulation during the test period. The temperature plate shall be provided by Maxwell Laboratories prior to the test samples. It is required that the controlled temperature water heater and circulating pump be supplied and maintained by the sub-contractor. In addition, it is required that the sub-contractor shall provide sufficient thermocouples and continuous chart recording of the temperature of four locations on the temperature plate as well as the case temperature values of eight of the ten samples during the conduct of each test program.

The test samples, mounted to the temperature plate, shall be installed in an environmental chamber with the necessary electrical connections to provide test power and sufficient diagnostics of performance conditions brought out through vacuum tight bulkheads to the monitoring area. Conditions of voltage, frequency and current shall be recorded continuously during the test, and the temperature and barometric pressure of the autoclave shall be recorded continuously as well.

The sub-contractor shall maintain liaison with the Project Manager at Maxwell Laboratories and shall submit periodic test progress reports, and copies of diagnostic data, where required.

At the conclusion of each test period, it is required that the sub-contractor carefully pack all test samples which have completed the vacuum endurance test, any failed samples, and ship directly to Maxwell Laboratories, along with two copies of a report covering the test made. Copies of all recorded charts shall be included with the test report. At the conclusion of all tests, return all remaining capacitors to Maxwell Laboratories.

After both vacuum endurance tests are completed, the sub-contractor shall return the environmental chamber to the destination specified and shall ship the temperature plate(s) to Maxwell Laboratories. Any other test equipment

furnished by NASA or by Maxwell Laboratories shall be returned to its point of origin.

### 6-3 TEST FACILITY CHECKOUT

The Vacuum Endurance Test Facility at Industrial Electric Heating is shown in Figure 6-2. The power supply (induction heater) is shown at the right with the vacuum tank in the center. The resonate coil is mounted on top of the vacuum tank. Next to the tank on the left is the monitoring and recording equipment, then to the far left is the water tank, pump and temperature controlling equipment.

Checkout of the facility was conducted March 4 and 5, 1982, by NASA and Maxwell personnel.

One of the prototype capacitors and one capacitor from the first production lot of 20 capacitors (Serial #140357) was hand carried to Industrial Electric Heating to be used during the checkout of the Vacuum Endurance Test Facility. The initial checkout was accomplished with an external water cooled capacitor consisting of four 2  $\mu$ F sections hooked in parallel to make up the 8  $\mu$ F load (10 x 0.8  $\mu$ F). This capacitor and resonate coil is shown on top of the vacuum tank in Figure 6-3. Then one of the 2  $\mu$ F sections was removed and replaced with two Maxwell capacitors as shown in Figure 6-4 and schematically in Figure 6-5.

There was some concern that the bushing rings might heat up since the capacitors were erroneously made with ferros rings, the voltage was run up in steps then turned off to examine the bushings for any heating. After 100, 250, 400 and 600 V ac, there was no noticeable heating.

The capacitors were then mounted on the cooling plate with thermocouples attached to the capacitor as indicated in Figure 6-6. The tank was evacuated and the capacitors were operated at 600 V ac at 10 KHz for 180 minutes. The resulting temperature rises are shown in Figure 6-7. It is of interest to point out that the prototype capacitor was built with brass studs and indicators approximately 5°F higher operating temperature than the production model which has copper electrodes. Both capacitors have conducting epoxy inside on the bottom, but neither one had the conducting epoxy on the outside ends. The conducting epoxy should reduce the heating on the final production capacitors. The body temperature rise of 20°F at this point is well within expectations.

After the initial setup tests, additional thermocouples were added to further explore the temperature variations about the test capacitors. Figure 6-8 shows the locations of all thermocouples on the two capacitors. A total of fourteen thermocouples were monitored during this portion of the setup test. There were three water temperatures recorded; the temperature at the water storage tank, where the water was brought to temperature, the inlet water fitting at the bottom of one side of the temperature plate, and the temperature at the outlet water fitting, located at the top of the opposite edge of the temperature plate. As expected, the outlet water temperature has been raised by excursion through the passages of the plate, heated by the energy transfer from the capacitors.

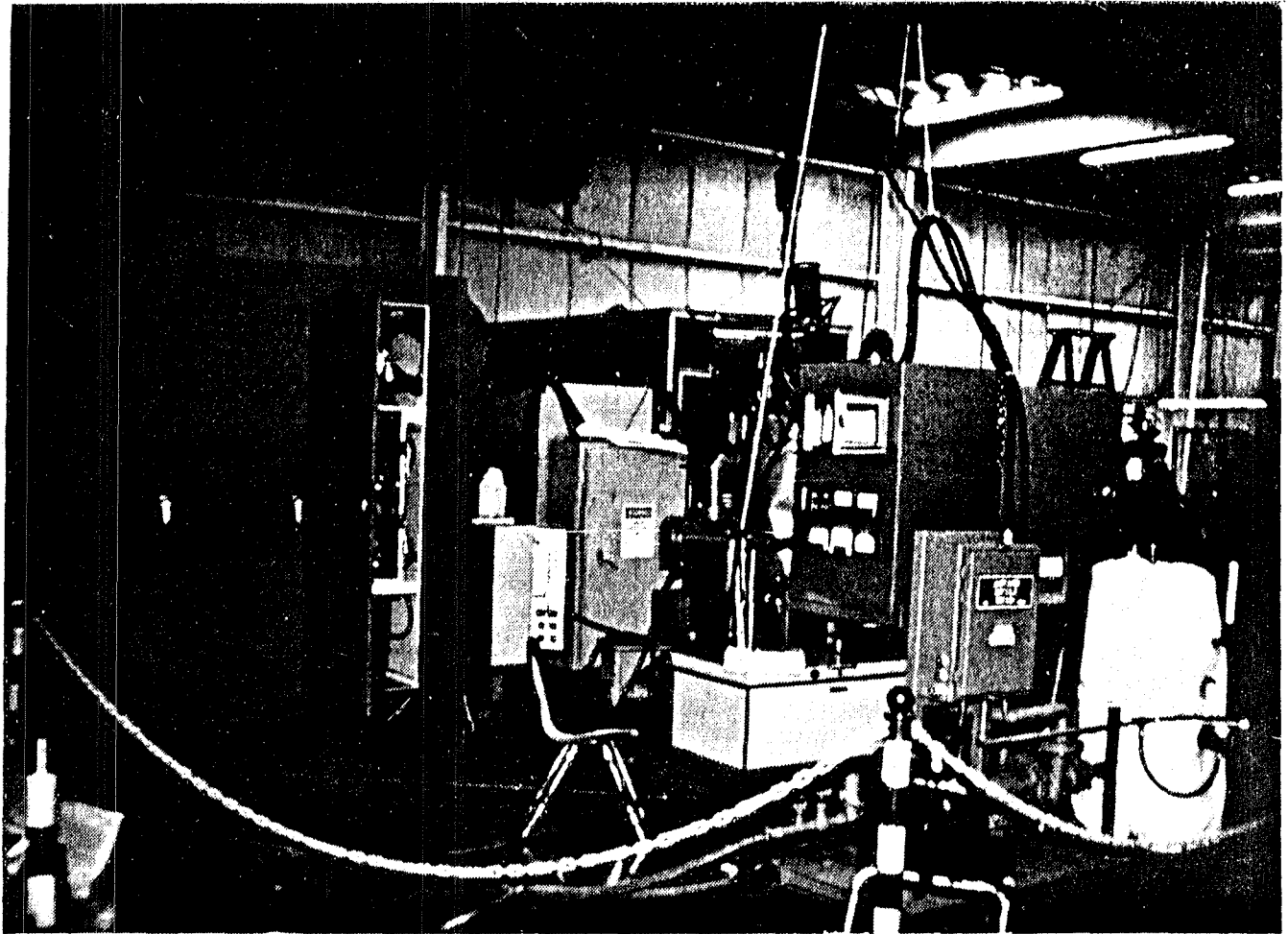

MLA-4295

Figure 6-2. Vacuum Endurance Test Facility

MLA-4293

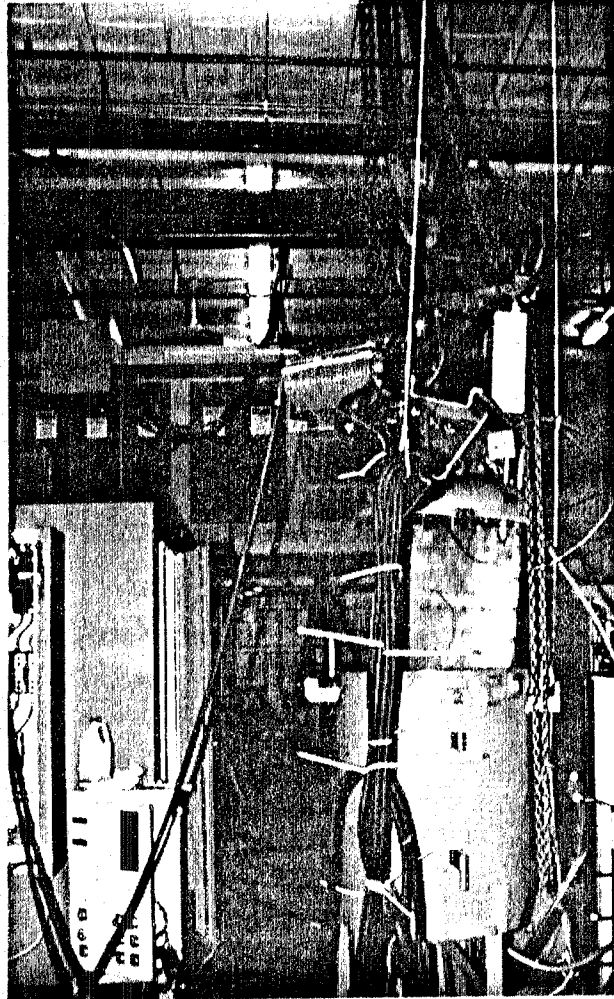

Figure 6-3. Vacuum tank external capacitor and resonate coil

MLA-4294

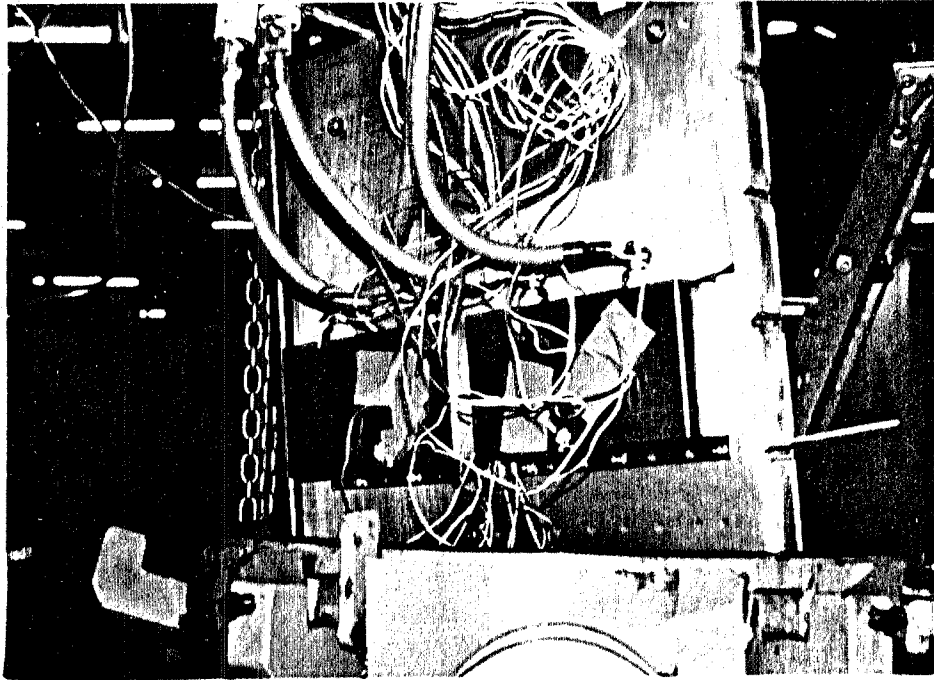
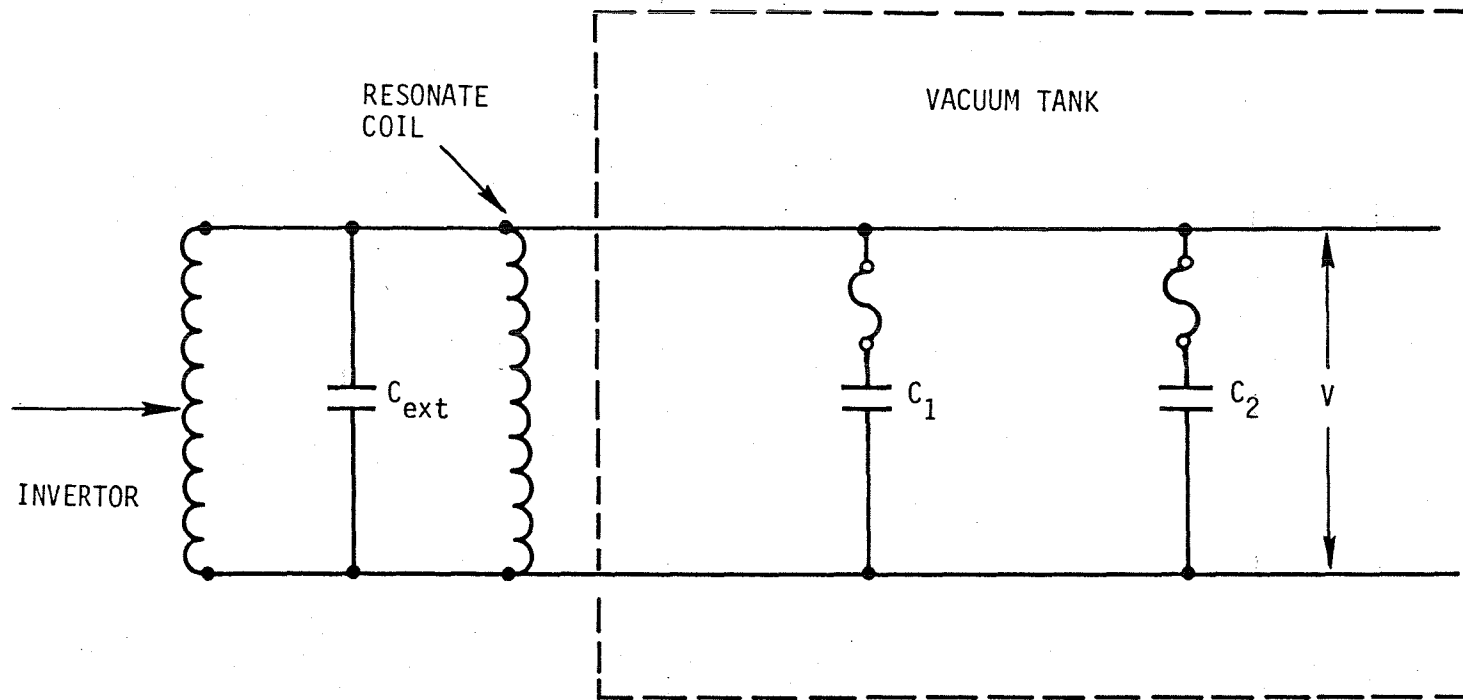

Figure 6-4. Test capacitors mounted to cool plate



$V_A$  600 V ac 10 KHZ

$C_{ext}$   $C = 6 \mu F$

$C_1$  and  $C_2 = 0.88 \mu F$  EACH

MLA-4305

Figure 6-5. Vacuum endurance checkout diagram

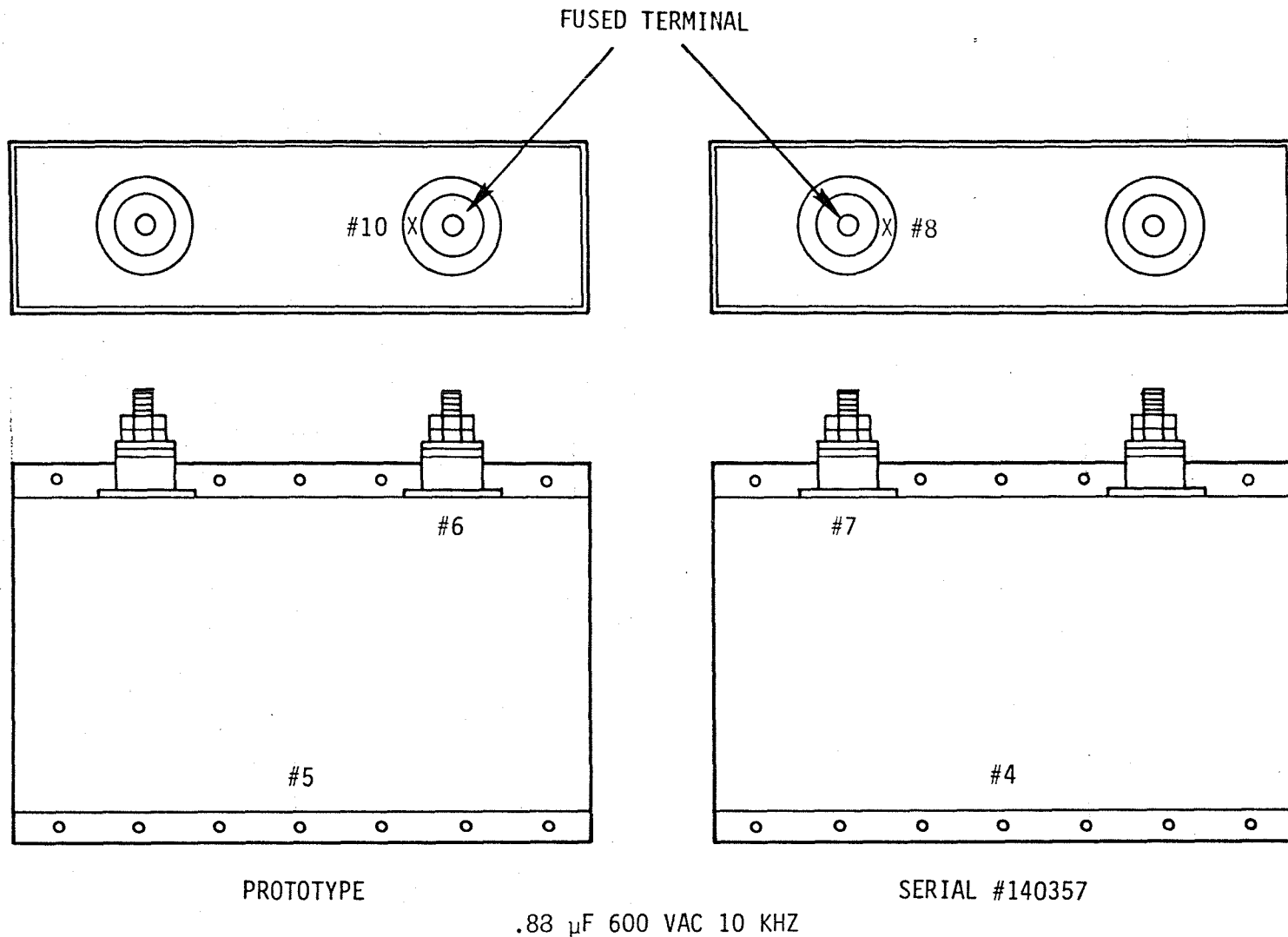

MLA-4306

Figure 6-6. Thermocouple locations



01-9

MLA-4303(B)

DEGREES F

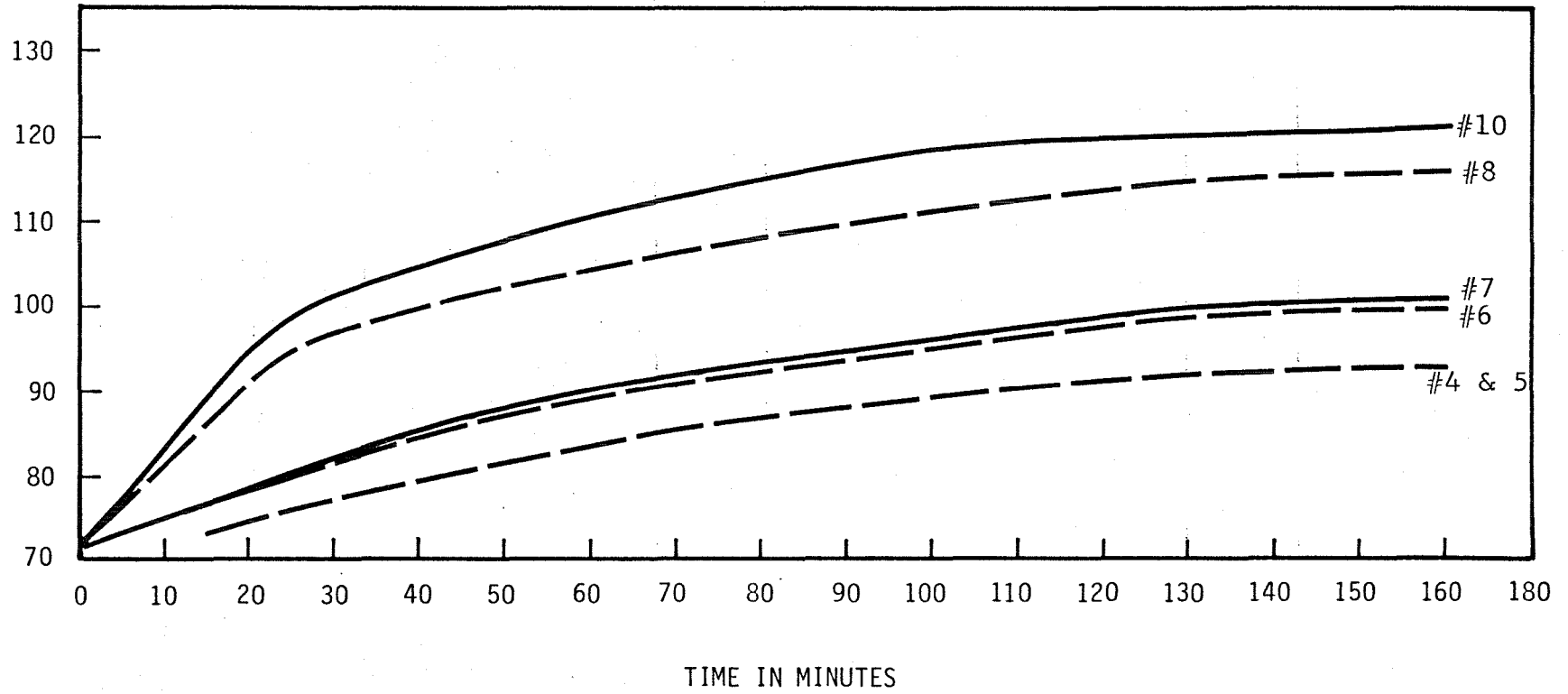
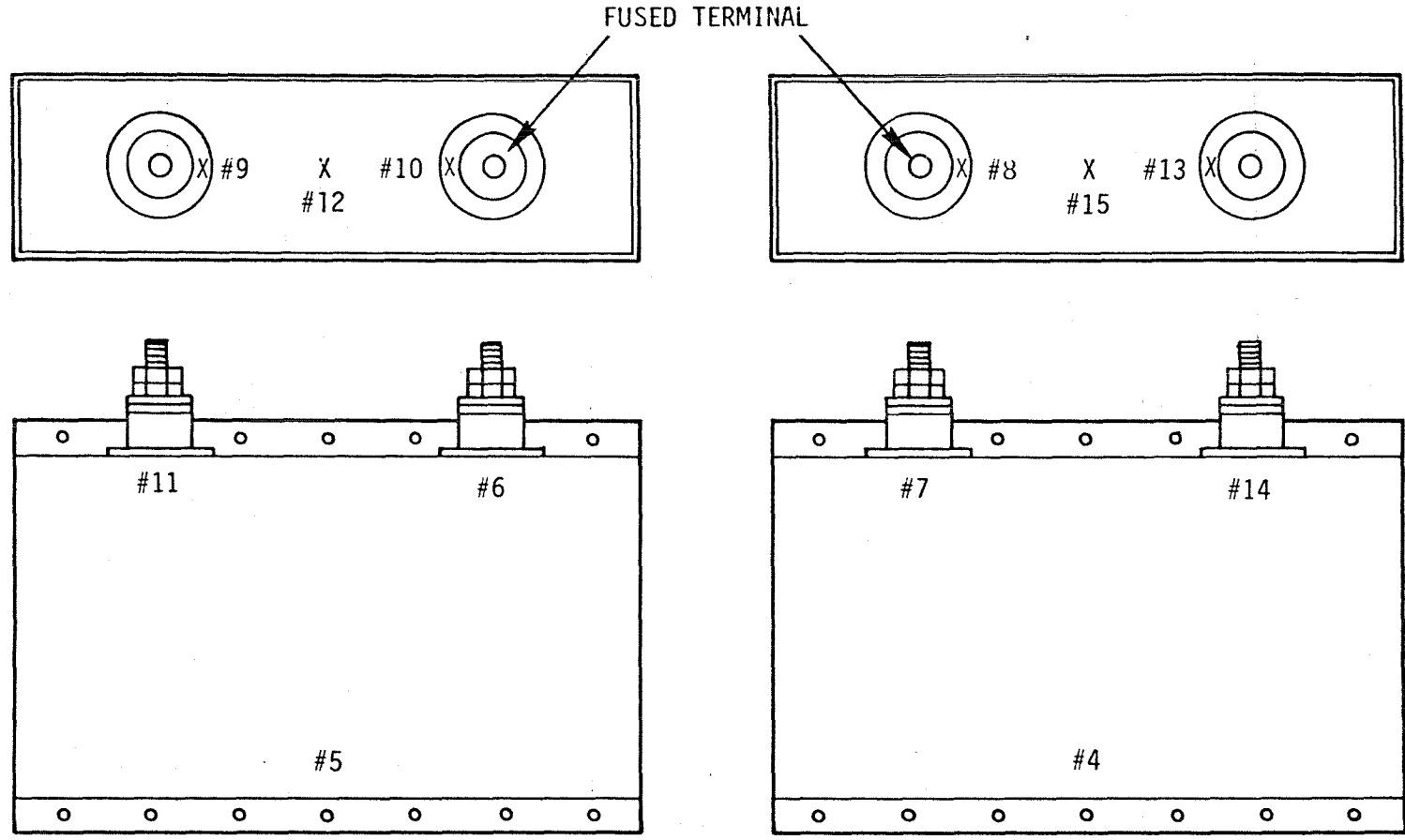

Figure 6-7. Initial test at 600 V at 10 kHz 72° water temperature

6-11



MLA-4313

PROTOTYPE

SERIAL #140357

.88  $\mu$ F 600 VAC 10 KHZ

- THERMOCOUPLE #10 - TEMPERATURE OUTPUT WATER
- THERMOCOUPLE #19 - TEMPERATURE INPUT WATER
- BOTH CAPACITOR - NO EXTERNAL EPOXY
- PROTOTYPE CAPACITOR - BRASS TERMINAL STUD
- SERIAL #140357 - COPPER TERMINAL STUD

Figure 6-8. Thermocouple locations

There was evidence of eddy current heating of the bushing flanges, but the temperature rise of the bushing flanges of the prototype capacitor was much higher than that of the first production unit. The only factor to which this condition can be attributed is the material used in the electrodes of the capacitors; brass for the prototype, and copper in the electrodes of the production unit. The resistance of the brass is approximately three times the resistance of the copper, and this factor could be an explanation of the higher spot temperature of the center of the cover on the prototype capacitor; a combination of heat transfer from the electrode and from the flange.

Two runs, at different water temperatures, were made on the two capacitors. The results were essentially the same, with the actual delta temperature rise values a bit lower at the higher water temperature. This is normal for a test of this nature, for the dielectric losses of polypropylene are lower at the higher temperature. The low point of tan delta of the polypropylene will be at a point which is favorable to temperature stabilization at the internal temperature of the capacitive elements when the temperature plate is maintained at the specified value for the Vacuum Endurance Test.

In order to pursue the investigation of the eddy current losses of the steel bushing flanges, the frequency was raised to achieve approximately the same energy transfer as on the earlier tests. At 300 VRMs and 38.6 kHz the flange temperatures had gone to 245°F on one of the bushings of the prototype capacitor after only 20 minutes operation. This is 80° above that same temperature point at a test frequency of 10 kHz. The effect must be divided between the result of increasing the current by 78 percent, and from the hard-to-quantify increase in induced losses from the eddy current effects. The flange temperatures of the prototype capacitor were significantly higher than those of the production unit.

Essentially the same result as reported in the previous paragraph was observed when the voltage was increased to 600 V ac at 40 kHz. The non-fused bushings of both capacitors quickly went offscale - over 300°F - in ten minutes at the power level of 80 kVar/capacitor. Significant was the observation that thermocouple #13, which had indicated offscale, was almost double the temperature of #14, located at a point adjacent to the same bushing flange monitored by #13. Local inductive heating of the steel bushing flanges is so great as to remove any consideration of performing the Vacuum Endurance Test at 40 kHz using capacitors with the present bushings. A special bushing with copper flanges will be used for the 40 kHz test.

After confirming the inadvisability of running additional tests at 40 kHz, a transformer was changed and the frequency reduced to 20 kHz. With the voltage at 608 RMS, and the frequency at 20.7 kHz, a test run of 150 minutes duration was completed with all thermocouples being monitored. Although the power transfer and RMS current had been doubled, compared to the earlier 10 kHz test, the temperature plate was approximately the same, and the temperature indications in non-flange locations were of acceptable rise levels. However, the flange thermocouples recorded temperatures much higher than before, indicating, of course, the eddy current heating in the steel flanges.

Two production capacitors from the initial production run, complete with heat transfer epoxy filling the base end and the bushing end, were mounted to the temperature plate in the same relative positions as the earlier prototype

and S/N 140357 capacitors. The two new capacitors are identified as S/N 140360, and S/N 140351, were mounted to the plate as shown in Figure 6-9. Also, 140351 capacitor was smeared on the mounting surface with high vacuum grease before mounting, to increase the thermal contact with the plate. No grease was placed on S/N 140360. The thermocouple locations were somewhat different than before, as shown in Figure 6-10, and no thermocouples were attached to the bushing flanges because of the epoxy. Variations then were the epoxy pour in the capacitor bases and covers, and the vacuum grease between the 140351 capacitor and temperature plate. Also, the water temperature was 140°F for this second 20 kHz test, compared with 127° in the earlier test.

Some compensation must be made for the higher water temperature, but the effect of the epoxy pour was significant; the temperature rise values were almost cut in half. Improvement of heat transfer from coating the capacitor surface contacting the temperature plate with grease was not as marked, but the effect was still significant; more so near the base of the capacitor, but also in the area between the bushings on the epoxy cast in the cover. At the end of 150 minutes, the duration of the test, the power transfer level per capacitor was 42.6 kVar. The maximum temperature recorded on either capacitor was 172°F, at the middle of the cover on the ungreased capacitor, 140360. The equivalent temperature of the greased capacitor was 159°F. An additional note in regard to the temperature of the circulating water; under most test run conditions the water temperature at the inlet to the plate was lower than the reservoir temperature, but the outlet water temperature was higher than that at the reservoir.

Another short run of 100 minutes at 600 V ac 20 kHz where the system was stabilized over night - unenergized - at a water temperature of 140°F. It was determined that the capacitor mounted with vacuum grease stabilized earlier within 80 minutes and at a lower temperature than the non-greased unit as shown in Figure 6-11. It was also confirmed the epoxy pour was beneficial in transferring the heat from the capacitors to the plate.

#### 6-3.1 500-Hour Vacuum Endurance Test at 10 kHz

The samples were taken from the plate and ten production capacitors mounted in the manner shown in Figure 6-12. Five capacitors were mounted on each side of the plate, oriented with bushings up when the plate is mounted in the autoclave. Water inlet is at bottom left edge of the plate, and the outlet is upper right. The water path in the plate is back and forth, horizontally, with two water passages under each capacitor. Thus, capacitors opposite each other on the plate share two water passages between them. The total plate capacitance is 8.837 mfd, as measured at 120 Hz. At 10 kHz and 600 V rms the total power transfer will be 200 kVar.

There are recordings of 24 values being made continuously during the test, 20 through 23 being millivolt recordings of current, frequency, vacuum and voltage, adjusted to be able to observe any change from initial conditions during the 500 hour test run. Inlet water and outlet water temperatures are being recorded at T0 and T19 respectively. The thermocouple locations are shown in Figure 6-13.

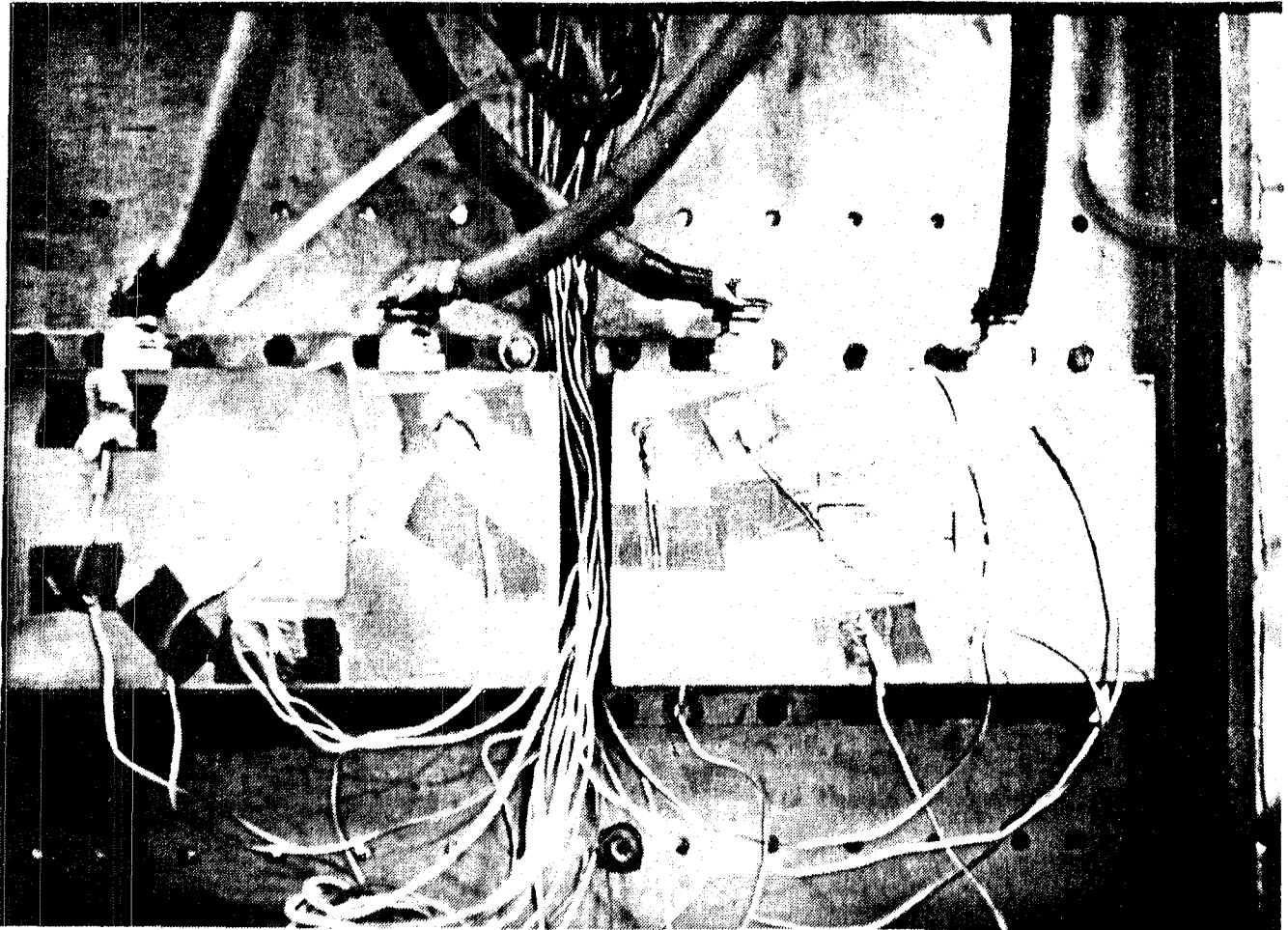

MLA-4296

Figure 6-9. Capacitor location for 20 kHz test

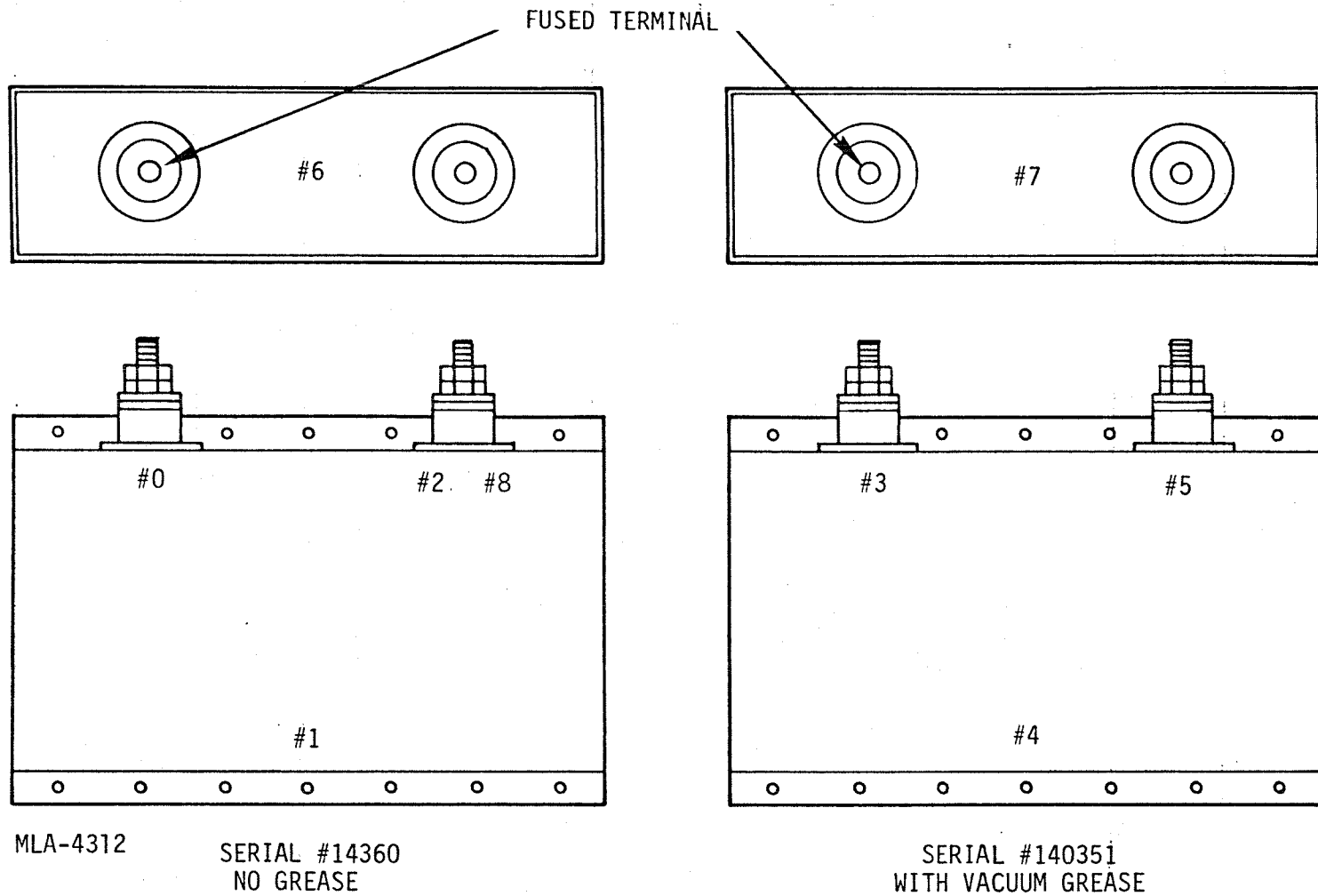

MLA-4312

SERIAL #14360  
NO GREASE

SERIAL #140351  
WITH VACUUM GREASE

.88  $\mu$ F 600 V ac 10 kHz

BOTH CAPACITORS HAVE EXTERNAL HEAT  
TRANSFER EPOXY TOP AND BOTTOM

Figure 6-10. Thermocouple locations for 20 kHz test

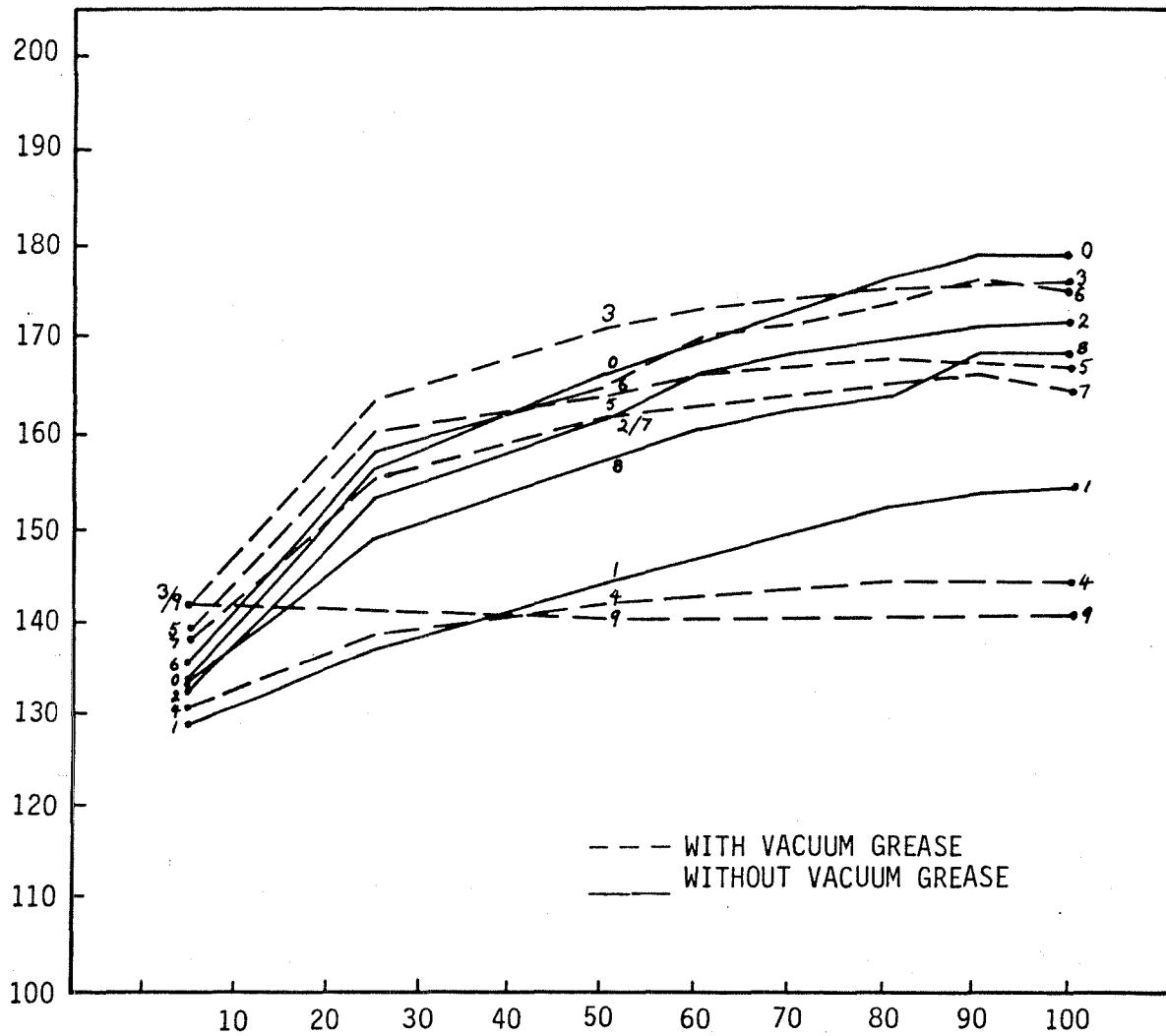

MLA-4311

600 V ac 20 kHz PLATE TEMPERATURE 140°F

Figure 6-11. Capacitor temperature rise at 20 kHz

MLA-4297

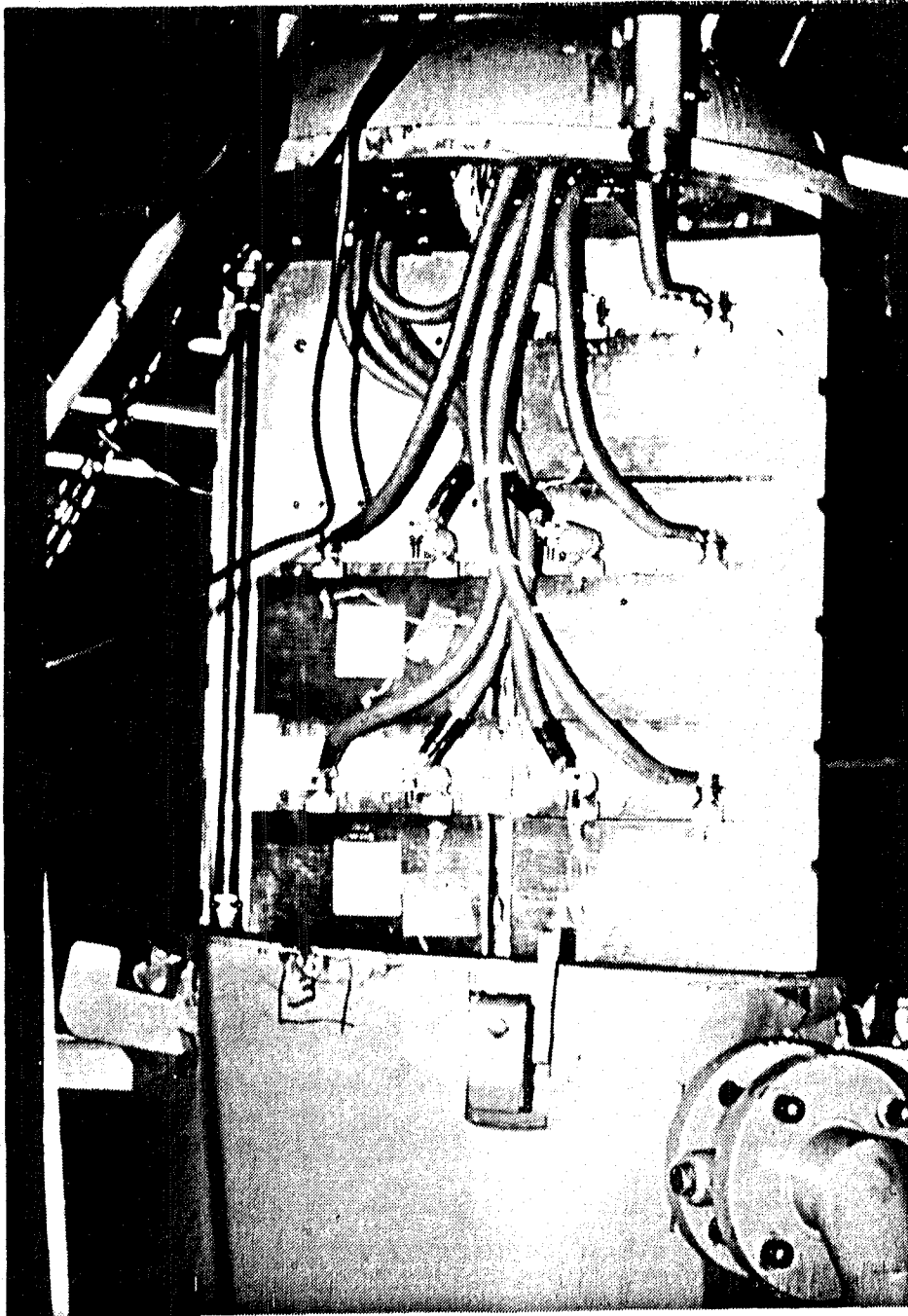

600 V ac 10 kHz

Figure 6-12. Capacitor location for 500-hour Vacuum Endurance Test



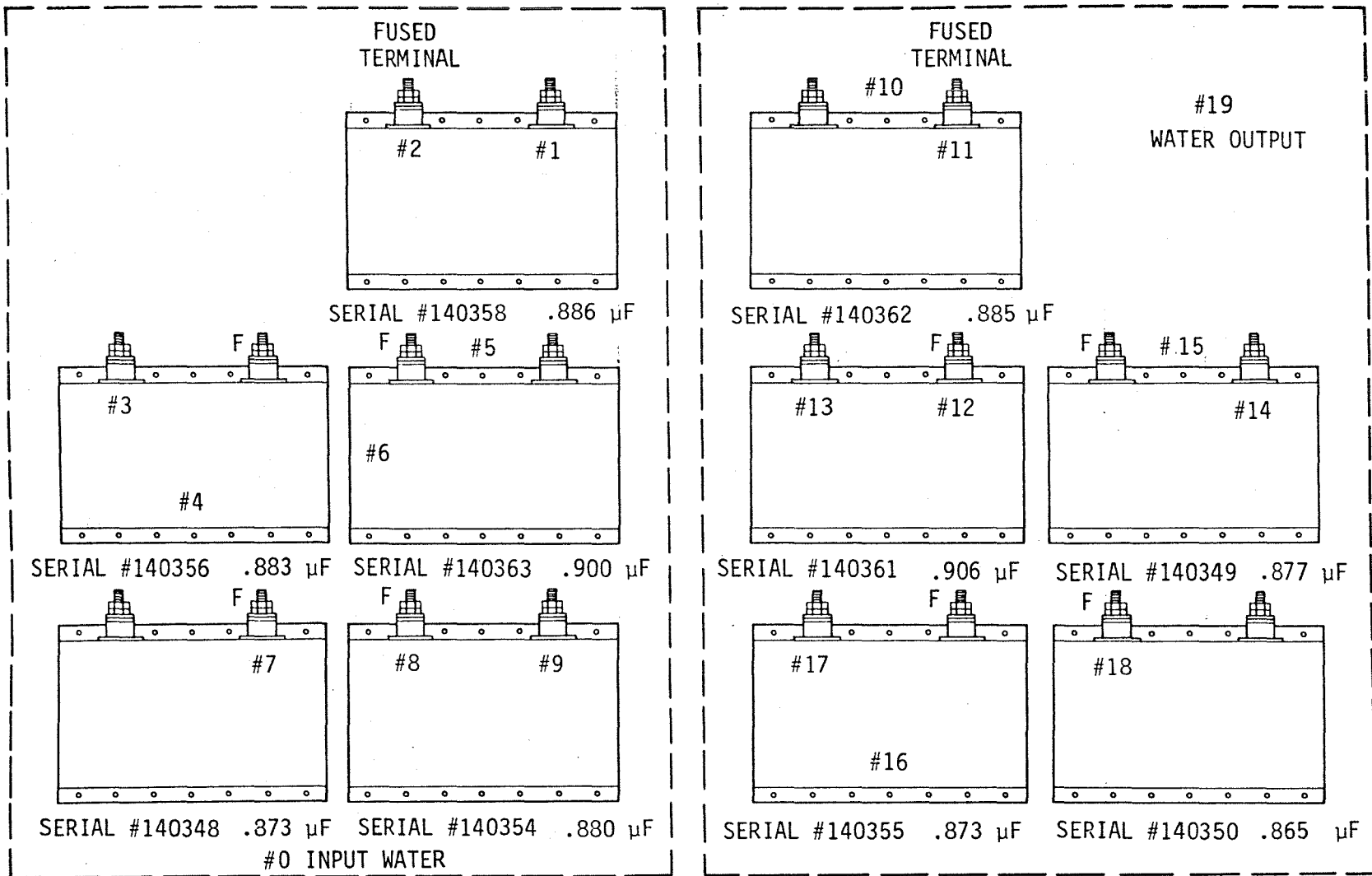

MLA-4308

FRONT

BACK

8.828  $\mu$ F TOTAL  
200 kVar

600 V ac      10 kHz  
333 AMPS

Figure 6-13. Thermocouple locations for 500-hour Vacuum Endurance Test

The 500-hour Vacuum Endurance Test was completed at the frequency of 10 kHz on 23 April 1982. All capacitors successfully passed the test to the specified conditions, and were removed from the test autoclave for measurement of capacitance after stabilizing at room temperature. "After Test" capacitance values were obtained from measurement on the same test instrument at IEH as was used to establish the initial, pre-test values. The measured values shown in Table 6-1 define the capacitance stability of the test samples.

The successful completion of the 500-hour test was certainly not unexpected, and the stability of capacitance of the test samples was a predictable result as well. However, the occasion of the test program presented an opportunity to observe the thermal performance of the capacitors under conditions significantly less stringent than would be encountered during the 40 kHz operation in the subsequent test program. To obtain maximum performance data the local temperature values in the areas shown in Figure 6-13 were monitored.

A number of observations regarding the thermal conditions can be made from the test data:

1. At 10 kHz, the ferrous material of the capacitor insulator flanges did not contribute to a significant temperature increase in that area.
2. Again, at 10 kHz, the copper/constantan thermocouples performed satisfactorily. As far as can be determined, the temperatures recorded can be used for accurate comparisons of performance, if not as absolute temperature values. In any event, any error generated by induced electrical currents in the thermocouple wire would be in the direction of increased temperature indications.
3. At the relatively low power transfer of 20 kVAR/cap only a moderate amount of heat was picked up by the temperature plate. However, the plate helps to establish the operating temperature of the capacitors in a thermal range of best dielectric performance, a factor which will be beneficial when the more exacting conditions of the 40 kHz Vacuum Endurance Test are confronted.
4. Examination of the temperature rise values of the various areas of the capacitors indicated that the presence of the fuses connected directly to the stud of a capacitor bushing distorted the temperature conditions of that capacitor. The average temperature rise of the nearby thermocouples was 19.7°F, compared to the average temperature rise of areas near unfused bushings at 8.3°F. Later calculation of the resistance of the 50 ampere fuses, and determination of the heat loss in the fuses, explains the temperature rise of the fused bushings. Needless to say, the 300 ampere fuses will be located away from the capacitors during the 40 kHz Vacuum Endurance Test.

TABLE 6-1  
CAPACITANCE STABILITY AFTER 500-HOUR TEST

SERIAL NO.	CAPACITANCE ( $\mu$ F) BEFORE	CAPACITANCE ( $\mu$ F) AFTER	CAPACITANCE ( $\mu$ F)	CHANGE (%)
140348	0.873	0.874	0.001	+0.115
140349	0.877	0.877	-----	-----
140350	0.865	0.865	-----	-----
140354	0.880	0.880	-----	-----
140355	0.873	0.873	-----	-----
140356	0.883	0.883	-----	-----
140358	0.886	0.889	0.003	+0.34
140361	0.906	0.908	0.002	+0.22
140362	0.885	0.888	0.003	+0.34
140363	<u>0.900</u>	<u>0.903</u>	<u>0.003</u>	<u>+0.33</u>
AVERAGE	0.883	0.884	0.001	+0.11

NOTE: Test Instrument - ESI #251 "Z" Bridge, 1 kHz

Figure 6-14 graphically displays the temperature rise values of all thermocouples shown in Figure 6-13. These values were recorded at the completion of the 500-hour Vacuum Endurance Test, and were stabilized over a considerable period of time. The reference temperature was that of the inlet water to the temperature plate; 140°F.

In addition to the clearly defined temperature difference between the fused and unfused bushings, several significant thermocouple values should be noted:

1. T5 and T10 represent center-of-cover temperature values of two capacitors in completely different locations on the temperature plate. Even so, the temperature rise values are the same; a modest 16°F in what would normally be expected the highest temperature point on a capacitor.
2. T6 is the only unique location of a thermocouple, and is on the front side of the temperature plate. This is fortunate, since the rise of 26°F would otherwise have been difficult to explain. The location of T6 is in a normally low rise area of a capacitor, but the rise in this case is the greatest of all points, due to its location at the confluence of four heavy cables, an area of the plate where one could expect maximum temperature.
3. T4 and T16 are identical points on capacitors on opposite sides of the temperature plate, and would be expected to exhibit low values of temperature rise if the epoxy temperature transfer material is properly transferring the local interior heat collected by the bottom extended foils to the bracket and then to the plate. A cable is in proximity to T4, which may account for the slightly higher value than shown for T16. The cable routing on the back of the temperature plate is not shown, but was the same as that shown in Figure 6-12. T16 was located on S/N 140355 where no cable was near, and should be expected to have the least temperature rise.

The capacitance values shown in Table 6-1 were obtained at IEH just before and just after the 500-hour test. The measurements were made at a frequency of 1 kHz, and no D.F. measurements were made, since capacitance was most important for tuning the power supply to the specified frequency. The 120 Hz measurement of capacitance and dissipation factor was made at Maxwell before the test capacitors were shipped, and the values recorded at that time. After the 500-hour test was completed, and some additional testing at higher voltage, the capacitor samples were returned to Maxwell and the measurements of capacitance and D.F. repeated under the same conditions as initially. These values are shown in Table 6-2.

VACUUM ENDURANCE TEST TEMPERATURE  
RISE VALUES AFTER 503 HOURS  
10 kHz

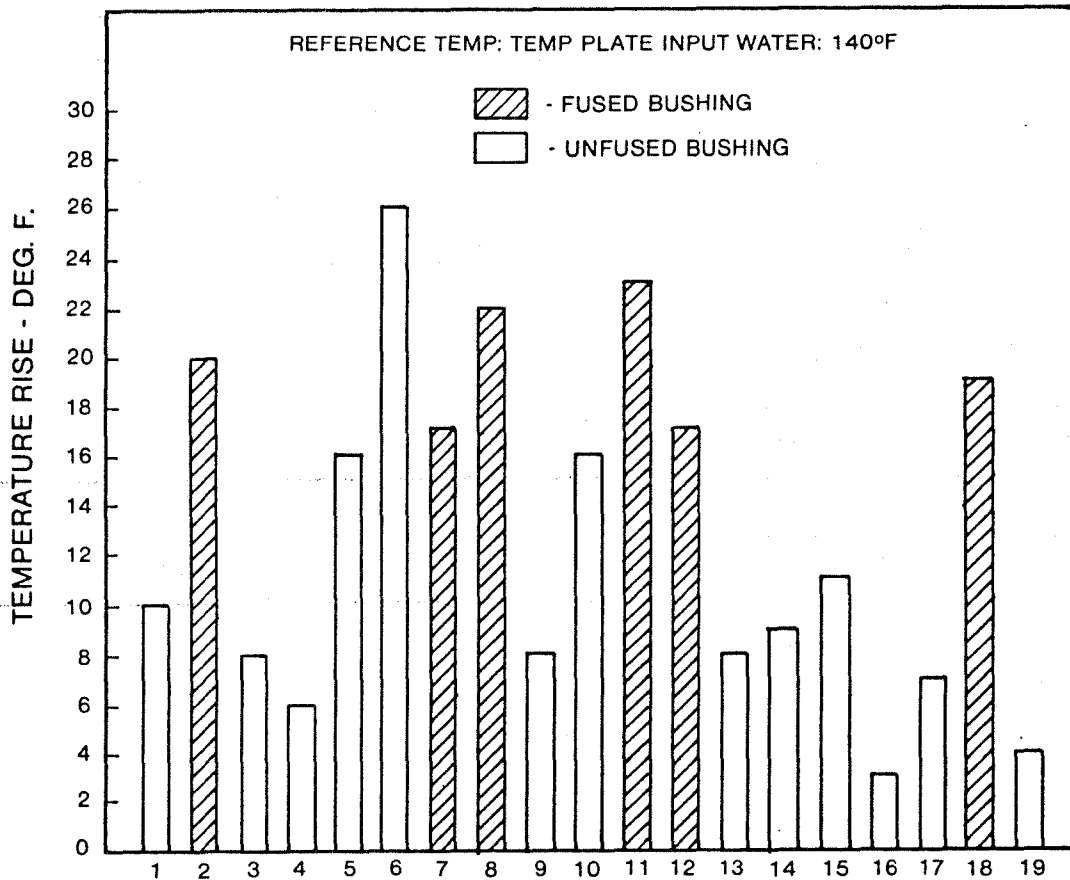

MLA-4307

THERMOCOUPLE IDENTIFICATION

Figure 6-14. Vacuum Endurance Test temperature rise values of thermocouples

TABLE 6-2  
ELECTRICAL MEASUREMENTS AT MAXWELL f = 120 Hz

SERIAL NO.	BEFORE		AFTER	
	CAPACITANCE $\mu$ F	D.F. %	CAPACITANCE $\mu$ F	D.F. %
140348	0.875	0.08	0.879	0.1
140349	0.879	0.05	0.880	0.05
140350	0.870	0.05	0.870	0.06
140354	0.881	0.08	0.882	0.04
140355	0.878	0.03	0.878	0.05
140356	0.886	0.06	0.888	0.06
140358	0.889	0.02	0.892	0.03
140361	0.909	0.03	0.910	0.03
140362	0.889	0.02	0.893	0.02
140363	<u>0.903</u>	<u>0.01</u>	<u>0.909</u>	<u>0.02</u>
AVERAGE	0.886	0.043	0.888	0.046

\*After completion of 500-hour Vacuum Endurance Test at 10 kHz

NOTE: Measured on: GenRad 1617B Cap Bridge, 120 Hz

After completion of the 500-hour test at 10 kHz and at 600 V rms the capacitors were apparently in very good shape and the opportunity was seized to increase the power transfer in anticipation of the severe conditions to be encountered in the subsequent 40 kHz Vacuum Endurance Test, and to learn a bit more about the performance of the capacitors and the test facility. In this regard the applied voltage was increased to 725 V rms which increased the average power transfer per capacitor to 30 kVAR; 150 percent of the transfer of the 600 V rms 500-hour test, and the temperature conditions monitored as before. This is still well below the power transfer to be maintained during the 500 hour test at 40 kHz, but would provide meaningful information, and no retuning of the power supply was required. Figure 6-15 relates the applied voltage vs. the kVAR power transfer for an average unit of 0.88  $\mu$ F. It is easily recognized that the kVAR/cubic inch volume of these capacitors is very high, compared with commercial power frequency capacitors, made possible by the excellent dielectric loss characteristics of the state-of-the-art polypropylene film and, of course, the high frequency of the applied voltage.

At the increased power transfer of the 725 V rms test, only five of the capacitors from the 500-hour 600-volt test were electrified, maintaining the original 10 kHz frequency by connecting the necessary tuning capacitance outside the autoclave. The 30 kVAR/capacitor transfer was maintained for a continuous period of 190 minutes, sufficient time to permit the capacitor temperatures to stabilize. Although all thermocouple temperatures were recorded, only those connected to electrified capacitors presented meaningful values. Comparison with final 600-volt temperature rises for electrified capacitor thermocouples is shown in Table 6-3. During this test period the same 50 amp fuses used at 600-volts were still in place.

After 190 minutes of operation at 725 volts, the applied voltage was increased to a value of 817 V rms, maintaining the frequency at 10 kHz. This was an increase in power transfer over the 600-volt test of 85 percent, and increased the current per capacitor to 45 amperes; apparently too much for the 50 amp fuses to handle continuously. One fuse opened, and the capacitance change resulting threw the bank out of resonance, blowing the remaining fuses.

The replacement fuses were rated at 150 amperes, and the larger fuses had significantly lower electrical resistance. This fact pointed up the effect of fuse resistance on the temperature rise value of thermocouples located near the fused bushings, the 150 ampere fuses lowering the temperature of the nearby thermocouples. Operational runs with the same capacitors, but with 150 ampere fuses, at 600 V rms and 725 V rms revealed a different temperature picture than that obtained with the 50 amp fuses. See Table 6-4 for the temperature rise values with the larger fuses.

Although additional test runs at voltage values over 800 volts were attempted, this value was so near the upper limit of the transformer that no voltage stability was possible. The 10 kHz test was terminated, and the capacitors returned to San Diego for additional measurements of their parameters.

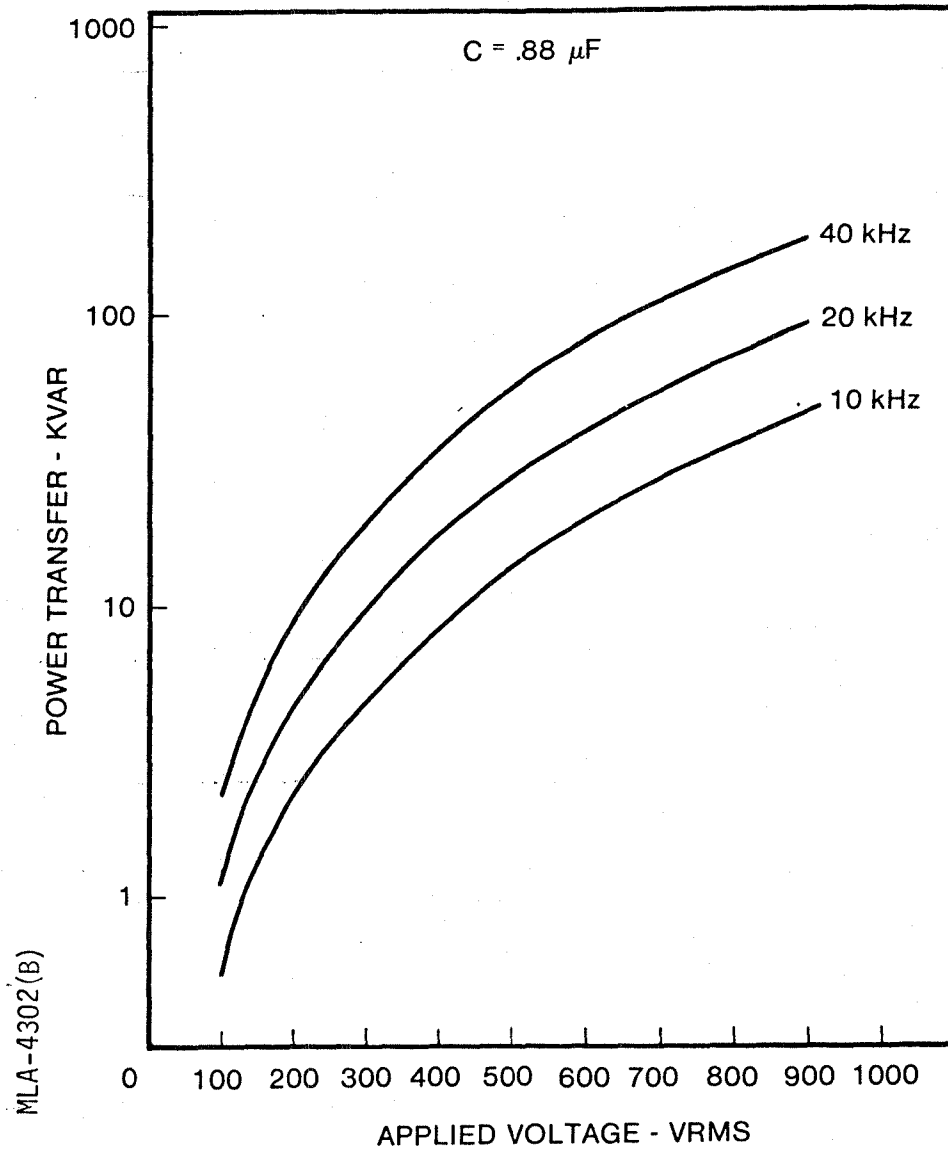

Figure 6-15. Voltage/frequency coefficient of power transfer



TABLE 6-3  
POWER COEFFICIENT OF TEMPERATURE RISE

SERIAL NO.	T.C. NO.	TEMPERATURE RISE 600 V rms	(Deg. F.)* 725 V rms
140356	T3	8	10
140356	T4	6	5
140363	T5	16	18
140363	T6	26	35
140354	T8	22	29
140354	T9	8	7
140361	T12	17	18
140361	T13	8	4
140349	T14	9	5
140349	T15	11	9

\*600 V rms - after 503 hours; 725 V rms - after 190 minutes test

NOTE: Capacitors all connected through 50 amp fuses

TABLE 6-4  
TEMPERATURE CONDITIONS FROM OPERATION WITH 150 AMP FUSES

SERIAL NO.	T.C. NO.	TEMPERATURE RISE 600 V rms*	(Deg. F.) 725 V rms*
140356	T3	0	10
140356	T4	-15	0
140363	T5	4	14
140363	T6	8	21
140354	T8	8	20
140354	T9	2	14
140361	T12	0	14
140361	T13	-1	13
140349	T14	0	13
140349	T15	0	10

\*600 V rms test stabilized after 320 minutes; 725 V rms test measured after 450 minutes

Table 6-5 lists the electrical parameters of capacitance and tan delta of the ten capacitors subjected to the 500-hour conditioning of the Vacuum Endurance Test. The values shown appear to display a significant degree of variation in regard to the Dissipation Factor (tan delta X 100) measurement. However, one is to recognize that the values shown are of such a low value as to be at the absolute low limits of the measuring equipment. As such, the variation is more apparent than real. The capacitors came through the 500-hour conditioning in fine shape, and appear - from the measurements - to be "good as new."

### 6-3.2 40 kHz Endurance Test with Modified Bushings

The capacitors submitted to IEHCo for the 40 kHz phase of the Vacuum Endurance Test embody exterior changes from the capacitors tested in the 10 kHz phase. It was reported that the steel flanges of the bushings (insulators) installed on the ten capacitors tested, initially performed satisfactorily at the test frequency of 10 kHz, and adequately also at 20 kHz, but overheated from induced currents when the frequency was increased to 40 kHz. To counter this, as an interim measure, a larger insulator with stainless steel flanges and terminals was installed on the capacitors submitted for the 40 kHz test. It is well that the larger bushing was employed, for the lateral forces coincident with the use of No. 0000 cable could be damaging to the original, smaller, insulators.

The initial installation of capacitors for the 40 kHz Vacuum Endurance Test was completed using 300 ampere fuses mounted to heavy angled brackets connected to the capacitor terminals, inside the autoclave, see Figure 6-16. No. 00 cable was retained at the higher frequency. Half of the capacitors - those on the "back side" of the temperature plate - were painted flat black to determine the thermal effect of this surface treatment. It was determined to make an initial run at 10 kHz to evaluate the thermal effect of the changes in bushings and fuses.

The black paint applied to half the capacitors was an air cure paint, which degassed when the pressure in the autoclave was decreased. When it became impossible to lower the autoclave pressure to the value specified for the test, the pump was turned off and the paint removed from the test samples.

After returning the capacitors - all unpainted - to the autoclave, the system was pumped down and the test samples electrified at 10 kHz and 600 V rms. After 115 minutes of operation under these conditions the power was turned off to observe the cooling effect. Before the power was removed, no thermocouple was exhibiting a temperature as high as the inlet water, and after 15 minutes without power, the temperature of all thermocouples had dropped an average of one degree F. This phase of the test was discontinued, and the conditions of test for 40 kHz were established.

The applied voltage at 40 kHz was initially set at 200 V rms, then increased to 300 V rms when no problem was observed. After only ten minutes at 300 volts it was evident that the thermocouples were inductively heating, since dramatic increases in temperature of certain locations was noted. Relocation of certain power input cables alleviated the high temperature problem, but the problem was merely transferred to another location. The entry point of the thermocouples into the autoclave was too close to the power bus, see top of

TABLE 6-5  
ELECTRICAL MEASUREMENTS AT MAXWELL  $f = 100 \text{ Hz}$

SERIAL NO.	CAPACITANCE ( $\mu\text{F}$ )	DISS. FACTOR (%)
140348	0.8725	0.012
140349	0.8753	0.008
140350	0.8644	0.01
140354	0.8789	0.008
140355	0.8722	0.007
140356	0.881	0.01
140358	0.8878	0.004
140361	0.9064	0.005
140362	0.8866	0.002
140363	0.9014	0.003
AVERAGE	0.8827	0.007

\*After completion of 500-hour Vacuum Endurance Test at 10 kHz

NOTE: Equipment - GenRad 716-C Capacitance Bridge.

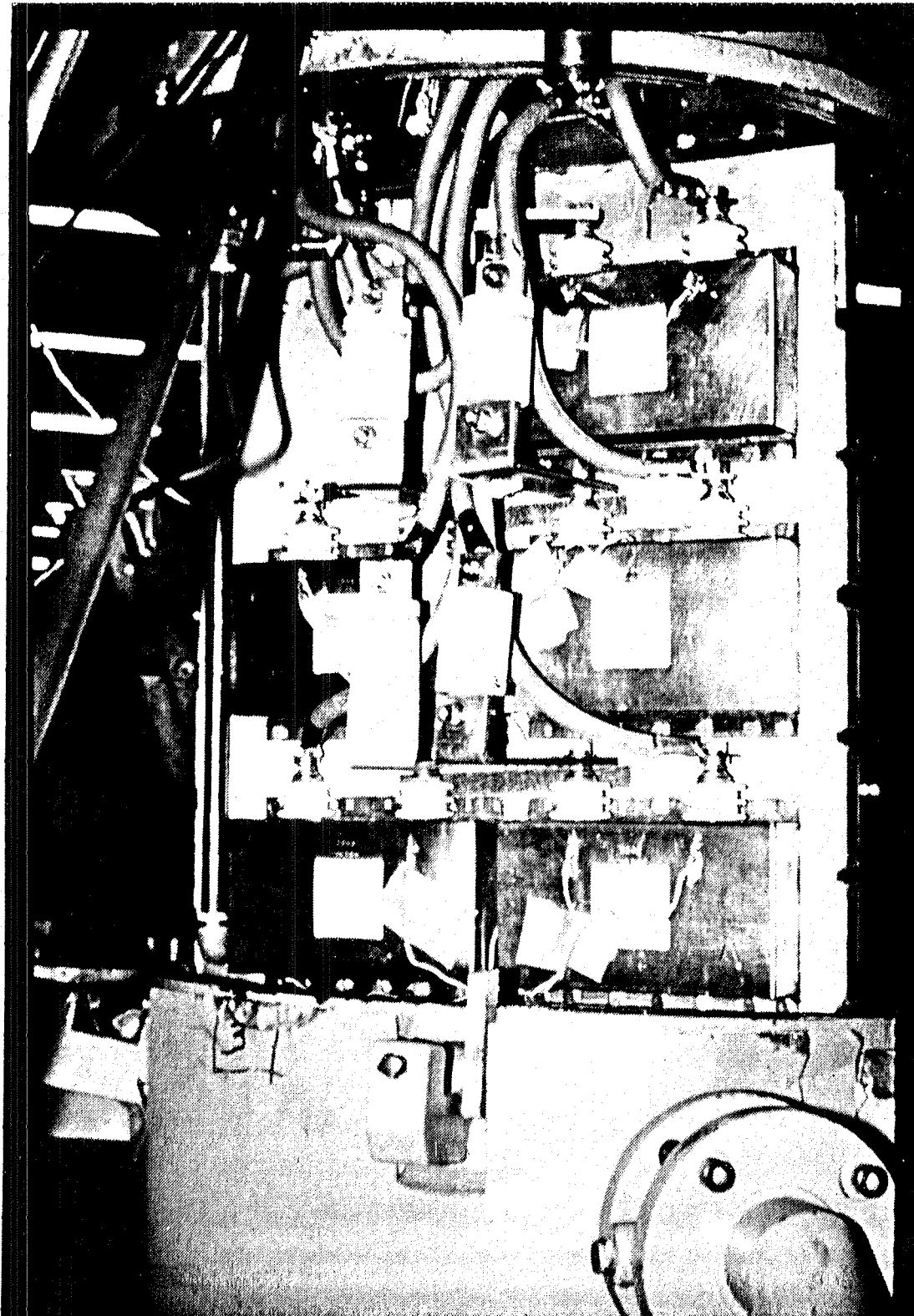

MLA-4298

Figure 6-16. 40 kHz test with 300 amp fuses

Figure 6-16, and the thermocouple fixture was redesigned. When the capacitors on the thermal plate - now located outside the autoclave - were energized, with thermocouples attached to the bottom capacitors in the front of the plate, normal temperature conditions prevailed as the voltage was raised to 400 V rms, then to 500 V rms. However, after operation at 500 V rms for only five minutes, the resonant power coil began to overheat. The transformer current probe was found to be burned out. After repair and connecting the coil cooling tubes to city water (to benefit from the high pressure) the capacitors were again energized, and after ten minutes at full power the resonant coil still overheated and the power cables to the capacitors were observed to be getting hot. It was decided to shut down and rework the system.

The reworking of the system involved the installation of the redesigned thermocouple entry fixture to the autoclave, rerouting of thermocouple wires along outside edges, installation of No. 0000 power cables to the capacitors, and replacement of S/N 140380 capacitor, where a terminal solder seal had begun to leak oil. S/N 140367 was installed as a replacement.

When the capacitor/plate assembly was replaced in the autoclave, the system pumped down and energized at 40 kHz and 300 V rms, it was noted that T.C. Nos. 5, 10 and 15 were giving erratic readings. The three thermocouples were removed and the system put back in operation. After increasing the voltage to 400 V rms it was found that the generator was going in and out of tune, requiring continual adjustment. Increasing the voltage to 500 V rms for ten minutes showed no heating of the capacitors, but some heat being generated in the No. 0000 cables. The coil settings were readjusted by means of the commutating capacitor, and adding snubber capacitors allowed for easier tuning of the coil for 40 kHz operation.

The system was reactivated at 600 V rms at 40 kHz at atmospheric pressure to observe the temperature conditions. As before, the coil overheated, the mounting bracket holding the temperature plate to the autoclave lid was heating up, and the chain holding up the lid was hot after only five minutes of operation. The lid mounting bracket and the chain are of mild steel, shown in top of Figure 6-17. Some of the plate mounting brackets were torched away to reduce the amount of steel in the 40 kHz field. It was found that two more capacitors, #140382 and #140381 had leaking solder seals, apparently due to repeated mounting as cables were changed and relocated, and were replaced with S/N 140378 and S/N 140379, respectively.

The capacitor/temperature plate assembly was returned to the autoclave and minimum pressure established. After applying 300 V rms for a short period of time, it was found that there was a vacuum leak at the power input point. The tank was opened and additional insulation added to the bus. Also, the external connection to the input power was reclamped. As the system was again energized, it became evident that the required environment could not be maintained because of outgassing in the chamber, said gassing producing a plasma which caused corona discharges when the capacitors were energized. A minimum pressure of 30 microns and a maximum voltage of 250 to 300 V rms brought on corona conditions, and this without the application of the dc bias voltage. Since the initial experience with outgassing had been attributed to the insulating jackets of the No. 00 cables, and had been overcome by continued pumping, it was judged that the heavier, black jacketed No. 0000 cables were the source of the current difficulty.

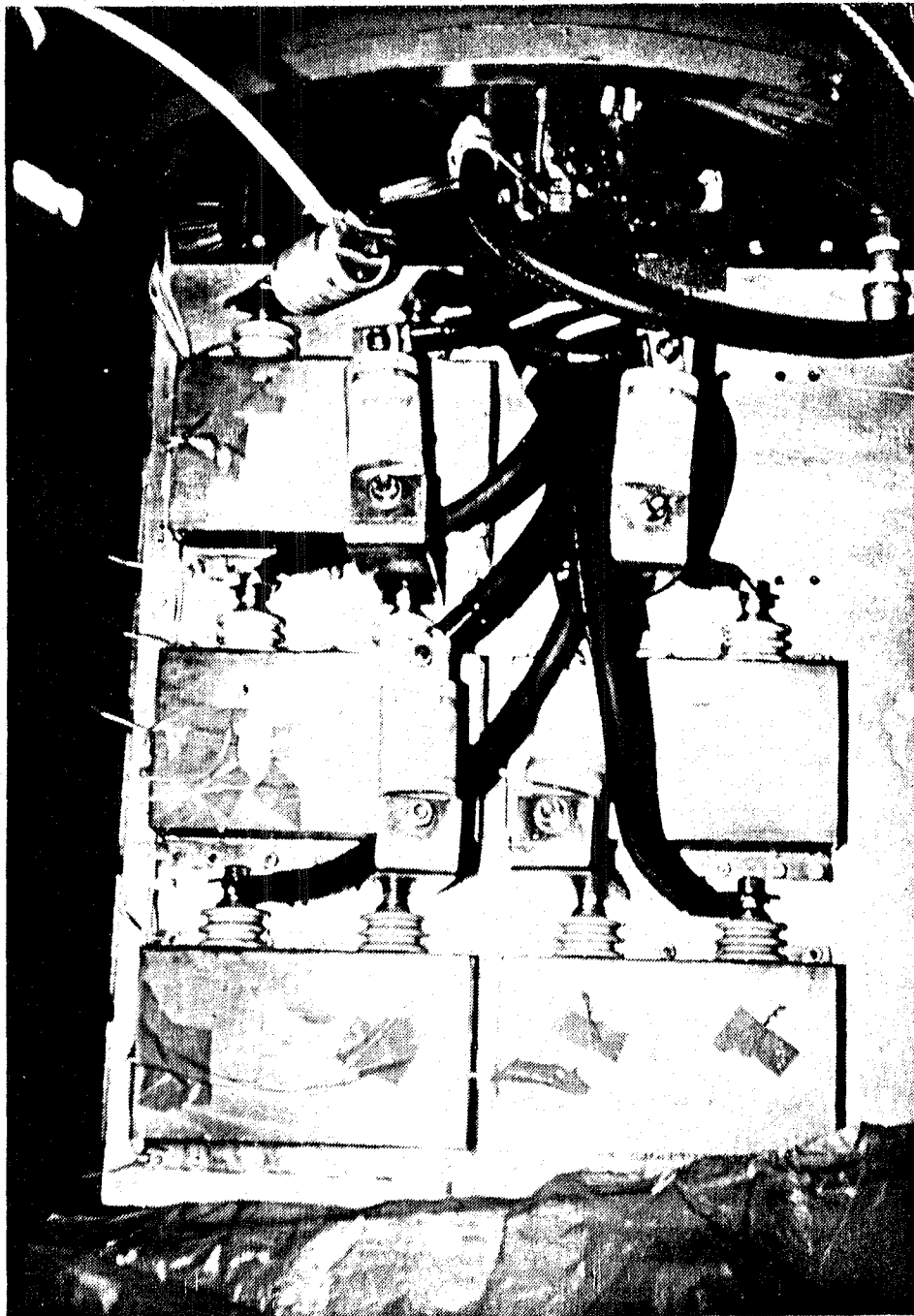

MLA-4299

Figure 6-17. 40 kHz test with No. 0000 cables

There being no readily available solution to the gassing problem it was decided to attempt an alternate plan of operating but four capacitors inside the autoclave, without bias, and powered through three No. 00 cables, instead of a single No. 0000 cable, and energize the remaining six test capacitors with 600 V dc bias atop the 600 V rms, in a mounting outside the autoclave at lab pressure and temperature. These six units would be tested without the temperature reference of the temperature plate. Figure 6-18 shows the electrical circuit employed to establish the proper ac and dc conditions.

First the test set-up was checked out in air for 1-1/2 hours with no problems, but when energized under vacuum again we were getting a plasma. A crack was discovered in the plexiglass plate where the power feed-through entered the vacuum chamber. A new plate was manufactured and installed, then another attempt to energize the system. As before, at around 400 V ac, we were developing a plasma in the tank. Long periods of outgassing at 320 volts did not solve this problem.

Again after many hours of dedicated effort it was determined that short of going to a larger vacuum tank and total rework, the best approach at this time would be to conduct the total test in air. As reported earlier, we encountered no problem at 10 kHz and 20 kHz in vacuum, so the vacuum integrity of the capacitor was verified, it was just a matter of too much power in too small a space.

The tank was vented and the 40 kHz test was started. The conditions now are as follows:

The test conditions for the four capacitors in the autoclave are at 600 V ac at 40 kHz with no dc bias operating at atmospheric pressure mounted to a cool plate at 140°F. The other six capacitors are mounted to an aluminum plate at room temperature, operating at 600 V ac with 600 V dc bias at atmospheric pressure as shown in Figure 6-19. The test circuit diagram is shown in Figure 6-20 with the capacitors, and thermocouple locations are shown in Figure 6-21. In this test mode the external capacitor will see a greater temperature delta due to the night and day change as well as the day-to-day change than the capacitor mounted on the cool plate.

During the start-up period of the test, we were not without our share of problems and delays including those of equipment breakdown as well as some schedule interruptions due to holidays and equipment relocation around the test area. The increased demand on the generator at 40 kHz took its toll on a few SCR's.



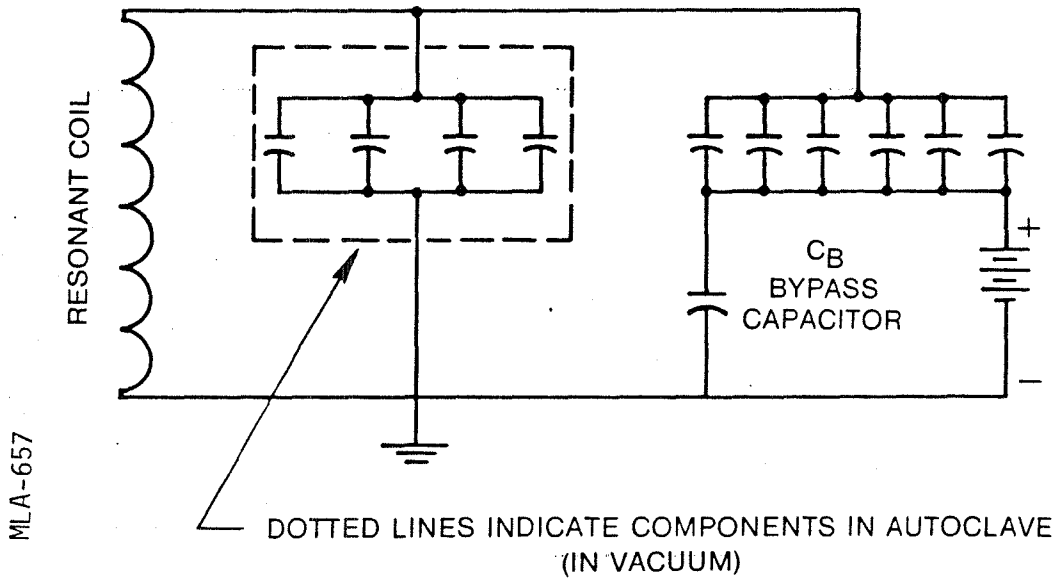
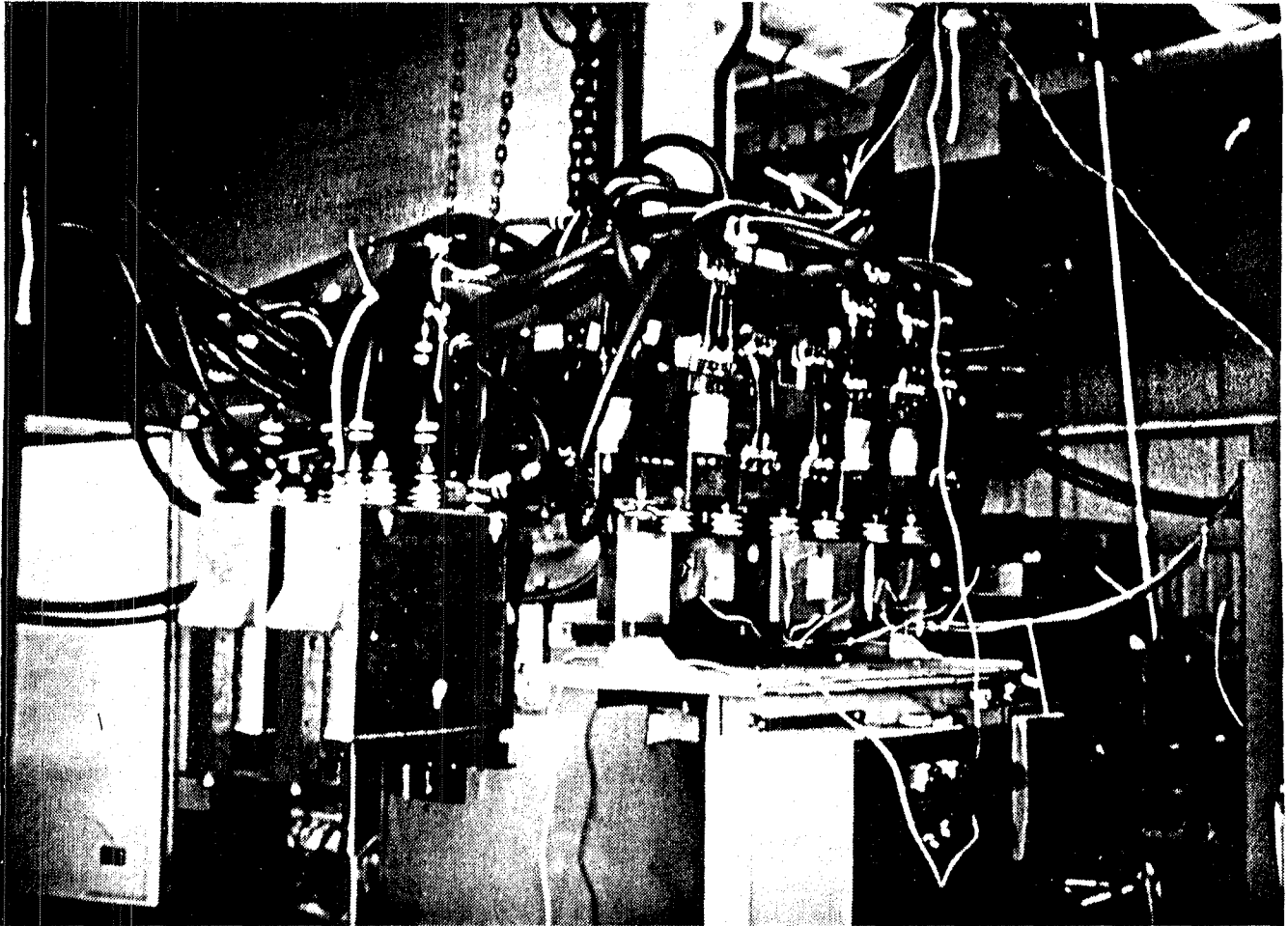

Figure 6-18. Test circuit diagram at 40 kHz ac with dc bias in vacuum



MLA-4300

Figure 6-19. External mounted capacitors for 40 kHz with dc bias

MLA-657

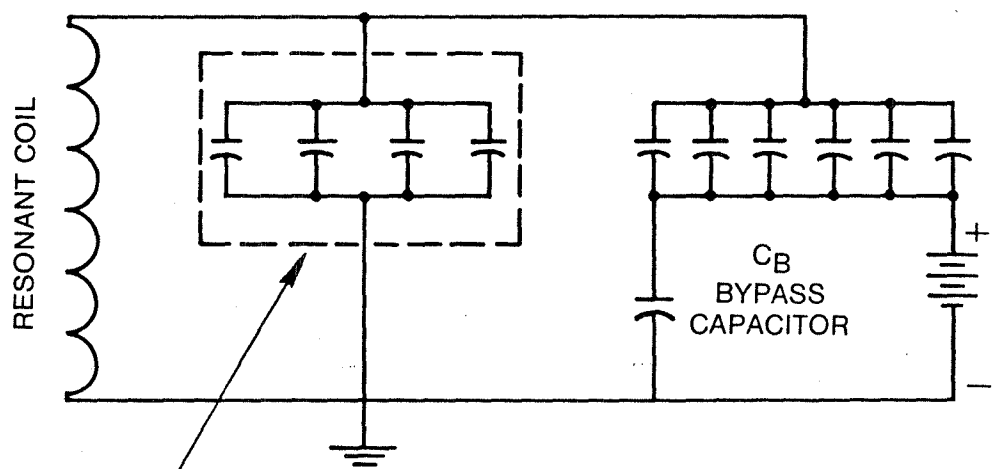

DOTTED LINES INDICATE COMPONENTS IN AUTOCLAVE  
(AT ATMOSPHERIC PRESSURE)

Figure 6-20. Test circuit diagram at 40 kHz ac with dc bias at atmospheric pressure

600 V ac, 40 kHz 500-HOUR ENDURANCE TEST

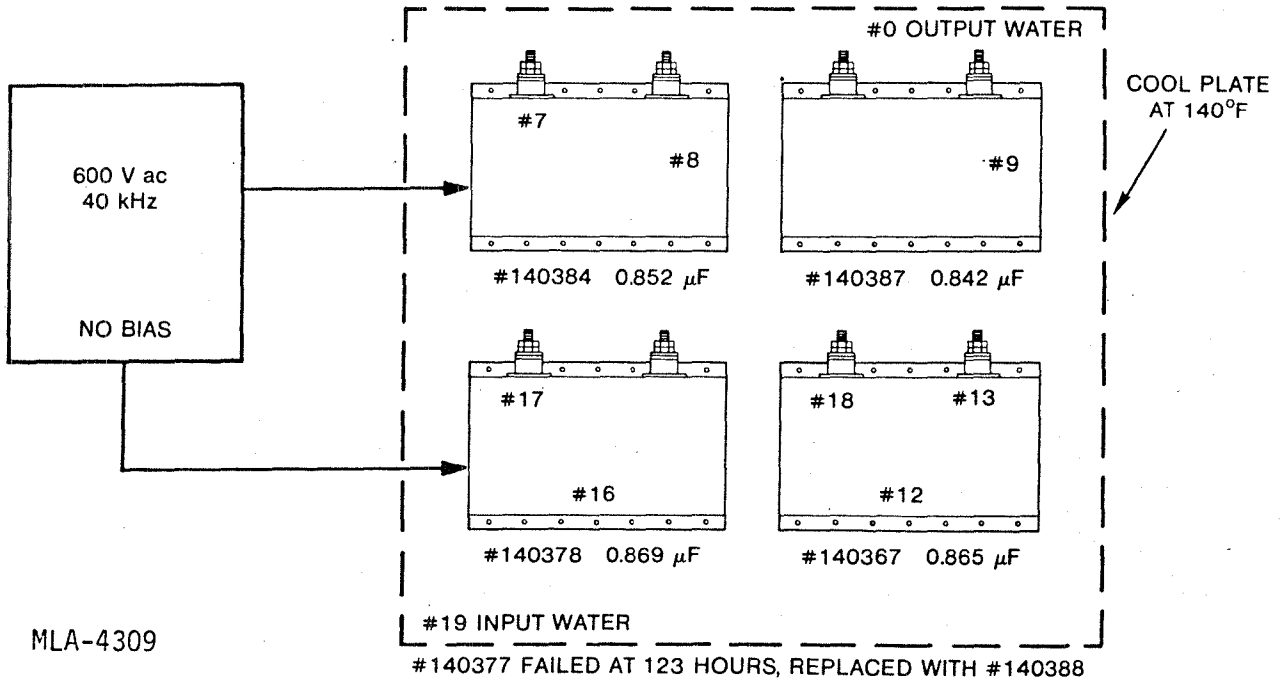
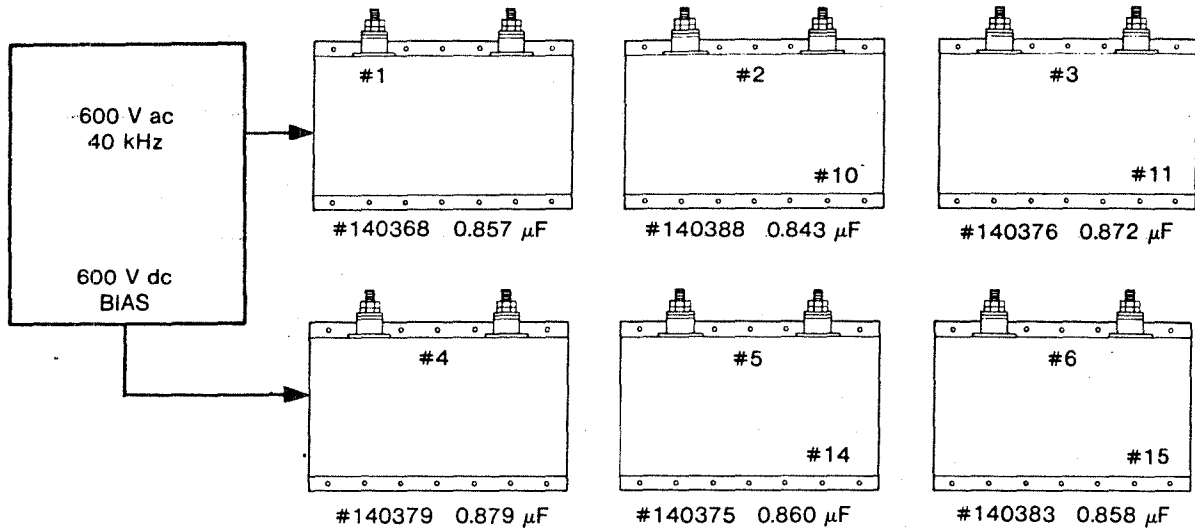

MLA-4309

Figure 6-21. Thermocouple locations for 600 V ac, 40 kHz 500-hour endurance test

### 6-3.3 The Qualification Test on the Final Version Capacitor

Nineteen capacitors were furnished to IEH for the qualification test on the final version capacitors. The test facility was modified to operate at 600 V ac, at a frequency of 10 kHz, the temperature plate at 140°F with ten capacitors in vacuum. The first group of capacitors was operated at the specified conditions for fourteen hours. The temperatures stabilized within two hours and as expected, lower than during the first test at 10 kHz. After 13 hours the voltage was raised to 800 V ac. This results in a power increase from 18.8 to 33.4 kVAR and a current increase from 31.3 to 41.7 amps. The temperatures stabilized within one hour. The capacitors were operated at the level for three hours, then this phase of the test was terminated for the first group of capacitors.

One capacitor, serial #140399, was left on the test fixture and nine other units were installed for the second run. After 30 hours of testing at 600 V ac at 10 kHz, this phase of the testing was terminated. The tank was opened and five of the capacitors were disconnected from the circuit. The tank was evacuated and the frequency raised to 20 kHz to determine frequency effect on the final capacitors. This results in a power level of 37.9 kVAR and a current of 62.6 amps. After 19 hours of testing, the voltage was raised to 800 V ac with frequency still at 20 kHz for a power level of 66.8 kVAR and a current of 83.4 amps. The temperature stabilized within 2 hours. After testing for 4 hours the voltage was reduced to 600 V ac and within two hours the temperatures returned to the range before the voltage increase, a good indication that no harm had been done to the capacitors. The testing was terminated at this point. A summary of the test conditions is shown in Table 6-6.

TABLE 6-6  
SUMMARY OF FINAL TESTING

	VOLTAGE	FREQUENCY kHz	HOURS OR TEST	kVAR	CURRENT
GROUP 1	600	10	13	18.8	31.3
	800	10	4	33.4	41.7
GROUP 2	600	10	30	18.8	31.3
	600	20	19	37.5	62.6
	800	20	4	66.8	83.4

SECTION 7  
SECOND GENERATION (Phase II) CAPACITOR DESIGN

From analysis of the data obtained during the vacuum endurance test of Phase I capacitors it is apparent that some considerable improvement in energy density of Phase I capacitor can be achieved without significant reduction in performance quality or reliability.

There are a number of capacitor components worthy of attention with weight reduction in mind, where such a shrinkage does not necessarily reduce the quality of function of the parts. An example would be the electrodes carrying the current from the capacitive elements to the load. The high frequency of the ac current limits the penetration of the current to the outer surfaces of the conductors, so the relatively large electrodes may be hollowed out, thus reducing the weight significantly without harming the function, since there is little need for mechanical strength of these items.

Another instance of justifiable weight reduction is represented by the case and bracket assembly of the capacitor. A change in design of the case contour results in reducing the length of the case periphery and increases the strength endowed by the shape. The case material of the Phase I capacitor is very probably overstrong, and a drop from 20 Ga. to 26 Ga. stainless steel is certainly warranted, particularly if the volume of the case can be further reduced by changes in volume of the capacitive elements.

The temperature data recorded in many locations on the capacitors, and also on a number of spots about the temperature plates, indicate - to us - that the anticipated need for assistance in transferring heat out of the interior of the capacitor to the temperature plate was not required. It is probable that less interior heat was generated than the analysis indicated. There were envisioned heat loss areas where accurate analysis was virtually impossible; such as, the solder/foil swaging areas in eight locations on the pad ends, etc. In any event, it appears to be a viable concept that at least two of the three areas where heat conducting epoxy was cast in place can be considered unworthy of such attention, and the layer of epoxy inside the case - at the bottom - which serves a dual function of heat transfer and pad location, is the only epoxy whose existence can be justified.

Since the energy content of a capacitor is exponentially proportional to the electrical stress on the dielectric system, it becomes very obvious that the easiest route to higher energy density is by decreasing the dielectric thickness. One is also aware that such a decrease is accompanied by an exponential decrease in capacitor life; that is, if dielectric degradation is the mode of capacitor failure. If the life test performed reveals unit failures, and the failure is attributed to progressive deterioration of the dielectric material at that point, than other capacitors in the test group will reveal significant losses in dielectric quality. This can be confirmed by electrical

measurement, and/or by physical examination. If such a condition is indeed revealed then any consideration of decreasing the thickness of the insulating material is out of the question, and increased energy density is limited to that obtained from minor changes in the physical makeup of the capacitor. It transpires, normally, that the small changes resulting from maximizing the efficiency of the capacitor envelope are inconsequential. The dielectric stress factor is all-important.

The Phase I capacitor design was predicated on the fact that operation at a frequency of 40 kHz continuously was a certainty. Consequently, all factors of pad design; the aluminum foil conductors, the dielectric thickness, the solder swagging, all were established on that basis. All insulating materials exhibit an inverse frequency coefficient of dielectric strength, as observed many years ago in a test program carried out by a group at Ft. Monmouth. Although there is little data available to quantify this effect, it is generally recognized that this parameter - ac dielectric strength - is exponentially affected. Again, the design of the Phase I capacitor took this into account, and the design of the pads, the arrangement of the capacitor circuit, was contrived to lower the interfoil voltage to a value where at least a 2X safety factor prevailed at the maximum frequency of application; 40 kHz.

The dimensions of the current carrying components of the capacitor were established, to a degree, by the frequency of operation. Any reduction in the frequency value increases the current carrying thickness of a conductor - the "skin effect" - thus decreasing the heat loss, and exponentially reduces the  $I^2R$  losses in the pad foils, the tabs, and the electrodes. A reduction in operation frequency from 40 kHz will reduce the resistive losses by a factor greater than four.

It is quite likely that a significant increase in energy density can be made over that established by the Phase I capacitor design, and still maintain reliable performance over the intended period. However, it is more rewarding to contemplate the effect of lowering the operating frequency to 20 kHz, while maximizing the capacitor envelope at the same time. In this regard a "Phase II" capacitor design has been prepared, a weight and thermal analysis recorded, and a mechanical design sketched out for consideration. Table 7-1 shows a weight analysis, and Figure 7-1 presents the shape and dimensions of a capacitor of increased energy density.

There was little reason to make any change in the type of dielectric film employed in the design of Phase I capacitor, nor was it necessary to make a new choice of dielectric impregnant. As far as can be determined at this time both materials performed completely as expected during the vacuum endurance test program.

TABLE 7-1  
CAPACITOR WEIGHT ANALYSIS

COMPONENT	COMPONENT WEIGHT (GRAMS)	
	<u>Phase I</u>	<u>Phase II</u>
Winding (4)	784.0	368.0
Poly Screen (2)	6.2	3.0
Fiber Screen	2.0	1.0
Epoxy	600.0	150.0
Bottom Tab	15.0	12.0
Electrode Assy (2)	109.0	80.0
Lid and Bushing Assy	250.0	180.0
Case w/base bracket	1112.3	450.0
Nuts (2)	21.8	21.8
Poly Beads	172.0	120.0
Poly Rod	4.0	4.0
Oil	292.0	185.0
Fill Plug	<u>18.0</u>	<u>9.0</u>
TOTALS	3386.3	1583.8



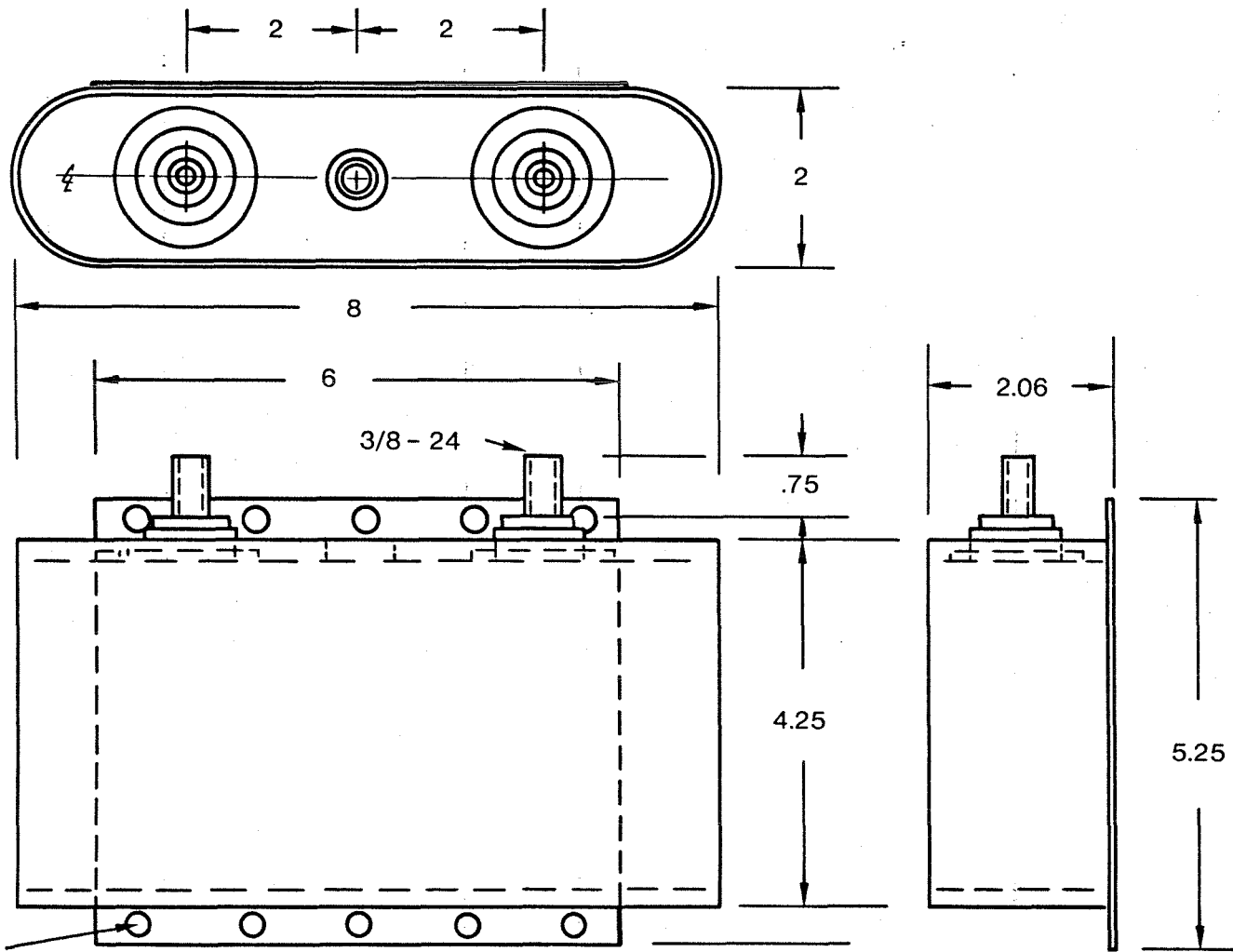

7-4

.25 D  
10 PLC

MLA-4310

Figure 7-1. Proposed capacitor design - Phase II

**End of Document**