

DOE/NASA/20320-45
NASA TM-83323

(NASA-TM-83323) FABRICATION OF LOW-COST
MOD-0A WOOD COMPOSITE WIND TURBINE BLADES
Final Report (NASA) 70 p HC A04/MF A01

N83-27347

CSCL 10A

Unclas

G3/44 03911

Fabrication of Low-Cost Mod-0A Wood Composite Wind Turbine Blades

R. F. Lark
National Aeronautics and Space Administration
Lewis Research Center

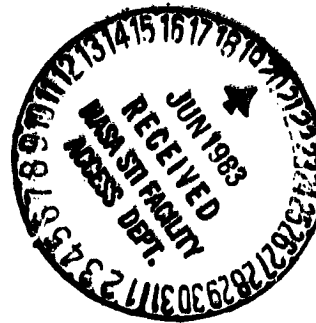

and

M. Gougeon, G. Thomas,
and M. Zuteck
Gougeon Brothers, Inc.

February 1983

Prepared for
U.S. DEPARTMENT OF ENERGY
Conservation and Renewable Energy
Wind Energy Technology Division

DOE/NASA/20320-45
NASA TM-83323

Fabrication of Low-Cost Mod-0A Wood Composite Wind Turbine Blades

R. F. Lark
National Aeronautics and Space Administration
Lewis Research Center
Cleveland, Ohio 44135

and

M. Gougeon, G. Thomas,
and M. Zuteck
Gougeon Brothers, Inc.
Bay City, Michigan

February 1983

Prepared for
U.S. DEPARTMENT OF ENERGY
Conservation and Renewable Energy
Wind Energy Technology Division
Washington, D.C. 20545
Under Interagency Agreement DE-AI01-79ET20320

FABRICATION OF LOW-COST MOD-OA WOOD COMPOSITE WIND TURBINE BLADES

R. F. Lark

National Aeronautics and Space Administration
Lewis Research Center
Cleveland, Ohio 44135

and

M. Gougeon, G. Thomas, and M. Zuteck
Gougeon Brothers, Inc.
Bay City, Michigan

SUMMARY

A contract was awarded to Gougeon Brothers, Inc. by NASA-Lewis Research Center, under Department of Energy sponsorship, for the development and fabrication of two sixty-foot, low-cost, wood composite blades for service on a 200-kw Mod-OA wind turbine machine. The contractual effort consisted of blade design and analysis, and fabrication phases. This report provides a brief summary of the design and analysis phase, and an in-depth review of the blade fabrication phase.

The wood composite blades were fabricated by using epoxy resin-bonded laminates of Douglas fir veneers for the leading edge spar sections and honeycomb-cored birch plywood panels for the blade trailing edge or afterbody sections. The blade was joined to the wind turbine hub assembly by epoxy resin-bonded steel load take-off studs. The wood composite blades were installed in the newest Mod-OA wind turbine test facility at Kahuku, Hawaii called Makini Huila (wind wheel) by The Hawaiians.

The wood composite blades have successfully completed high power (average of 150 kW) operations for an eighteen month period (nearly 8 000 hr) before replacement with another set of wood composite blades. The original set of blades were taken out of service because of the failure of the shank on one stud. An inspection of the blades at NASA-Lewis showed that the shank failure was caused by a high stress concentration at a corrosion pit on the shank fillet radius which resulted in fatigue stresses in excess of the endurance limit. The remainder of the blade, including the imbedded portion of the fractured stud, and the entire wood structure was found to be in excellent condition. All of the remaining studs, with the exception of four studs that showed an onset of corrosion, were also in excellent condition. The failed stud, as well as the four corroded studs, were successfully replaced with new studs. The blade is currently in a service-ready condition.

1.0 INTRODUCTION

Alternate forms of energy sources are being developed and exploited primarily to displace, in part, the use of petroleum fuels for electrical power generation and for industrial processing and domestic heating requirements. Wind is a form of sun-generated energy which is readily available but has not been significantly exploited in recent times. Although the potential of wind energy has long been recognized, and at one time provided the only means for

long distance travel and trade, insignificant utilization and virtually no research has been the rule during the recent past. This was mainly due to the former availability of low-cost petroleum fuels for electrical power generation and transportation.

The Department of Energy (DOE), Office of Energy Technology, Division of Distributed Solar Technology assigned to NASA-Lewis Research Center the task of developing large diameter, cost-effective, horizontal-axis wind turbines for electrical power generation. Preliminary studies (ref. 1) indicated that initial installation and subsequent maintenance costs of such systems are high and must be significantly reduced if wind-derived electrical power would become cost-competitive with present methods for power generation. Because the rotor blades of a large diameter, high power wind turbine machine constitute the largest element of total machine cost, programs were funded by DOE to develop cost efficient wind turbine blades.

Prototype, Mod-OA wind turbine machines were designed, fabricated, and placed into service to provide operational experience. The Mod-OA wind turbine is a 200 kW, horizontal axis, down-wind machine using a two-blade, 125-foot diameter rotor. This wind turbine generates electrical power in winds from 7 to 40 mph and uses blade pitching to control power output. These machines were originally equipped with aluminum blades made by using typical aircraft wing construction processes. Although blade costs were high for prototype quantities, initial operation showed that the blades were suitable for efficient power generation. Extensive experience with these blades indicated that the aluminum blades did not have the required longterm fatigue properties and were high in cost (ref. 2). This experience dictated that a new approach to blade fabrication would be needed to provide blades having both low-cost and long-term operational properties.

The feasibility of designing and fabricating Mod-OA blades from a laminated wood composite structure was evaluated by an exploratory study awarded to Gougeon Brothers, Inc. (GBI). The results of this study (ref. 3) showed that it was feasible to construct wood composite blades that would meet Mod-OA structural requirements. Consequently, a contract (DEN3-101) was awarded to GBI on a competitive basis to design and construct 2 blades for the Mod-OA wind turbine.

The result of the GBI effort was the design and fabrication of a set of laminated wood composite blades, the first set of which were installed on the Mod-OA wind turbine shown in figure 1 at Kahuku, Hawaii. This wind turbine is called Makinu Huila (Wind Wheel) by The Hawaiians. Three additional sets of Mod-OA wood composite blades were fabricated (under other contracts to GBI) and placed in operation at Culebra Island, Puerto Rico, and at Block Island, Rhode Island. The third set of blades was used to replace the original set of wood composite blades at Hawaii that were taken out of service because of a failure in the shank of one stud. The shank failure was caused by a high stress concentration at a corrosion pit on the shank fillet radius which resulted in fatigue stresses in excess of the endurance limit. The wood blade structure was found to be in excellent condition. The failed stud, as well as four other studs that indicated an incipient corrosion condition, were replaced with new studs. The blade is currently in a service ready condition.

Contract DEN3-101 was organized into blade design and fabrication phases. A detailed description of the blade design and analysis is described in a contractual interim report (ref. 4). A brief summary of the blade design phase, as well as an in-depth presentation of the blade fabrication phase is presented in this report.

2.0 BLADE DESIGN SPECIFICATIONS

The design specification requirements are summarized in this section. Included are brief descriptions of specifications that concern blade geometry and aerodynamics; blade weight and balance; loads and design cases; root-end-to-hub interface; and blade/cost weight requirements.

2.1 Blade Geometry and Aerodynamics

The wood composite blade set (two blades) were designed to provide an electrical power output of 200 kW at a rotor rotational speed of 40 rpm at a free-stream wind velocity of 15 mph at the rotor disk. The blades were to be designed to NACA 230XX series airfoil sections, shown in figure 2. A linear twist of ten degrees from root-end to tip was specified. The maximum allowable thicknesses of the blade sections were 40-percent of the chord length at the blade root-end and 18-percent of the chord length at the blade tip, with a linear variation between root-end and tip. The goal of the aerodynamic design was to develop a blade which minimized thickness and chord width without penalty in aerodynamic performance.

2.2 Blade Weight and Balance

Specifications for blade weight concerned restrictions on the location of the center of gravity and the uniformity of weight from blade-to-blade. The center of gravity location was specified to be forward of the 32-percent chord-line point, with a chordwise tolerance of less than +1-percent. For a two blade set, the tolerance in spanwise center of gravity was specified to be within 1 inch. Specifications for maximum root gravity moment and blade weight were 47 000 foot pounds and 3 000 pounds respectively. The tolerance on blade-to-blade weight was +2-percent.

2.3 Loads and Structural Requirements

Loads considered during the blade design effort consisted of a static hurricane wind and the cyclic working loads. The "hurricane gust condition" was to be modeled by a static flatwise load of 50 pounds per foot² of plan-form area. The cyclic load specifications required that there be no edgewise or flatwise fatigue failure resulting from blade bending moments. No-failure fatigue life under the cyclic loads was specified at 4×10^8 cycles (30 yr life). In addition, under these loads the blade must not yield anywhere, and the primary structure must not buckle.

Maximum allowable blade tip deflection was specified at 90 inches to provide for tower clearance. The blade natural frequencies for both edgewise and flatwise bending modes are described in detail in reference 4. Contractual specifications also included environmental resistance to operation over a -30° to 120° F temperature range, high humidity/salt spray, sunlight, fungus, and lightning strikes.

2.4 Root End-to-Hub Interface Requirements

Specifications required that the wood composite blades be capable of interfacing with existing Mod-OA wind turbine hub spindles. An intermediate spool piece could be used to mate with the shanks of the embedded steel load take-off studs on the blades and with the Mod-OA spindles. An extensive series of tests was conducted by NASA-LeRC personnel to demonstrate the fatigue-resistance of candidate load take-off study designs. The results of this study (ref. 5) were used to verify and optimize study design analysis and provide stud static and fatigue performance data.

3.0 BLADE DESIGN CONCEPT

The blade design concept developed under the contract for the fabrication of a 60-foot wood composite Mod-OA blade is described in this section. Included are summary descriptions of blade geometry, aerodynamic configuration, the root-end hub attachment concept, and lightning protection.

3.1 Blade Geometry

The wood composite blade was designed for a wind turbine system output of 200 kW at 40 rpm at a wind velocity of 15 mph (at the rotor disk). The geometry for the as-designed and constructed 60-foot length wood composite blade was chosen to minimize labor intensive construction processes and provide a low-cost blade. The blade geometry shown in figure 3(a) consists of a linearly tapered planform outboard from Station 168 (Station numbers refer to the numbers of inches in blade span from the axis of rotor rotation when the blade is attached to the hub flange of the blade hub/spool piece assembly) to the blade tip at Station 750. The blade shape inboard of Station 168 is a truncated section with no twist. The blade twist (fig. 3(c)) begins at Station 168 and varies nonlinearly to a 4.8-degree twist at the tip. The leading edge (nose) structure of the blade at Station 168 down to the root end at Station 50 is shaped to provide a thickened (4.5-in) wood structure for the insertion and bonding of steel load take-off studs in a 18-5/8 inch diameter bolt pattern.

The attachment of the blade structure to the wind turbine hub/spool piece assembly involved the bonding of 24 threaded studs into step-tapered holes drilled into the thickened root end wood structure. The studs were embedded into the wood structure a distance of 15-inches. Threaded shanks on the studs were fastened into the flange of the spool piece. The root end attachment arrangement is shown schematically in figure 4. Figure 5 shows a view of a Mod-OA stud. The embedded portion of the load take-off stud is tapered and has a modified ACME-type thread on its embedded surface to provide both an increased epoxy resin bonded shear area as well as a mechanical interlock between the adhesive and the wood structure.

3.2 Aerodynamic Configuration

A NACA 230XX series airfoil (fig. 2) was used for the blade airfoil shape in the power producing portion of the blade (Stations 168 to 750). As shown in figure 3(b), the blade thicknesses vary linearly in this portion of the blade, tapering from 19.8 inches at Station 168 to 1.8 inches at the blade tip at Station 750. Inboard of Station 168, the blade thickness increases to 22.5 inches.

As mentioned in the previous section the blade twist schedule begins at Station 168 and varies nonlinearly to a 4.8 degree twist at the blade tip. Although a 10 degree twist was specified in the contract, approval was given for this deviation. The primary reason for using the smaller twist was to implement the concept of linear leading and trailing edges into the blade design. The use of linear leading and trailing edge geometry was recognized as a significant aid in reducing the complexity of blade fabrication and minimizing blade costs. With a linear taper, the blade was trimmed in a single smooth plane, which simplified the use of the half-shell mold concept for blade fabrication. This half-shell mold concept will be described later in the report. Table I lists the chord lengths, thicknesses, thickness/chord length percents, and twists for the various blade Stations.

The planform of the blade was selected as a compromise between low blade solidity, as required by the contract specifications, and blade angle settings for optimum performance.

3.3 Lightning Protection

In the event that lightning were to strike the blades, a possibility exists that local impact, burning, or internal streamering could cause significant blade damage. Internal streamering could result in a rapid expansion of the moisture in the wood with explosive effects. To prevent this, and keep the charge on the outside of the blade, an aluminum window-type screening was used to cover essentially the entire outer surface of the blade. The aluminum screening would be bonded to the outer birch ply blade skin just below the outer resin and paint protective layers and a fiberglass cloth layer. The screening was to be attached to a grounding strap at the root end of the blade. The grounding strap would be connected to the wind turbine hub by means of a flexible cable.

The lightning protection concept was evaluated in simulated lightning-strike tests. A full-scale 20-foot length blade section of the wood composite blade was subjected to high voltage and current tests. The blade section was constructed with a laminated nose section and a trailing blade, or afterbody section made from honeycomb core sandwiched between plywood panels. The outer blade surfaces were covered with a thin layer of epoxy resin impregnated fiberglass cloth and full-coverage aluminum screening. A small aluminum rod was inserted partway inside the leading edge of the blade specimen to simulate internal wiring and other metallic components. Results of the tests, described in reference 6, indicated that the lightning protection concept effectively maintained the discharge currents on the blade surface and precluded penetration of the wood blade structure.

4.0 BLADE FABRICATION CONCEPT

The process selected for the fabrication of the low-cost, Mod-OA wood composite blade evolved from trade-off studies conducted during the design phase. The primary concern in blade fabrication was the type of molding process that would be used to bond the wood veneers and other materials into a reliable, low-cost structure. From the manufacturing standpoint, there are three major blade elements involved in the Mod-OA design; (1) the nose section, (2) the afterbody section, and (3) the longitudinal shear web.

4.1 Mold Concept

During the blade fabrication development phase, a decision was made to utilize female molds for the following reasons:

- (1) Exact surface contour reproducibility could be maintained from blade to blade and surface smoothness and overall blade fairness could be easily obtained and maintained once a set of accurate molds were produced.
- (2) Blade surface protection could be molded in place, which would minimize labor-intensive exterior finishing costs.

The female mold concept would construct the wood composite blade in two half shells by splitting the NACA 230XX airfoil approximately down the centerline and bonding together the two female half-shells, as shown schematically in figure 6. The advantage of this concept is that only two longitudinal external joining points are needed, one at the nose section and one at the trailing edge. One concern with this concept involved the accurate machining of an entire blade half in one operation. This was conducted by utilizing a specially designed band saw that could traverse the entire length of the blade with the saw blade held in the proper cutting plane. The band saw, shown schematically in figure 7, was designed to rest on a set of rails positioned at the outer perimeter of each of the female molds so that the saw could accurately traverse the length of the blades. This trimming concept provided accuracy in cutting as well as providing means to simultaneously cut all blade interior pieces and leading and trailing edges.

It was determined that the trimming point or "cut line" of the band saw could not follow the chord line of the airfoil section. This occurs because the chord line allows a slight reverse in one of the blade half sections and would result in significant molding problems. The solution to this problem was to establish a cut line from a point at the very leading edge of the airfoil section to a point in the center of the trimmed trailing edge. This departure of the "cut line" from the "true chordline," while minimal in dimension, greatly simplified the two half shell blade construction concept.

5.0 KEY BLADE COMPONENTS

This section describes key blade components and the materials used for their fabrication.

5.1 Nose Piece Laminate

The nose piece was constructed as a curved laminate of bonded veneer strips, as indicated schematically in figure 6. The wood species selected for the nose laminate was Douglas fir which accounts for approximately 70-percent of the blade weight. Douglas fir was selected for blade construction because this species best fit the following criteria:

- (1) Be available at a low cost per pound basis,
- (2) Have good physical properties for its density,
- (3) Be compatible with the blade manufacturing process.

The Douglas fir tree is indigenous to the Northwestern part of the United States and is considered a renewable resource because it is being replanted at a rate that exceeds the annual harvest. A large portion of the Douglas fir tree can be utilized to provide high quality veneer stock necessary for the fabrication of wood composite wind turbine blades.

During the design phase, a study effort provided definition how to economically utilize Douglas fir wood material with a female molding process. Sawn stock, or dimension lumber, in both square and rectangular shapes was initially evaluated but was soon rejected for the following reasons: (1) there was no developed efficient process for continuous application of adhesive on this type of wood material, and (2) it was difficult to conform relatively stiff and thick lumber sections into curved sections of the female mold. The use of Douglas fir veneer stock became the first choice because of the ready availability from a well-established veneer industry that provides raw material for the plywood industries. Tests conducted under the contract verified that veneer stock would be compatible with the female mold process.

Veneer stock is manufactured using two primary methods. One method is to slice the veneers from a log that has been sawn into sections. The next most common method provides a rotary cut veneer by positioning a veneer log in a lathe-type machine and then spinning the log against a horizontal knife that slowly moves in toward the center of the log. The knife peels off a relatively constant thickness of veneer on a continuous basis until the log is essentially consumed.

Although significantly more costly in terms of materials and labor costs, 1/16-inch thick sliced veneers were chosen for blade fabrication, primarily because of improved mold conforming properties compared to the relatively stiffer (and shorter) rotary cut veneers. Because sliced veneers, inherently have varying widths, depending on the width of the sectioned log, two or more trimmed veneers are temporarily bonded edge-to-edge by using a "stitching" machine that lays resin preimpregnated fiberglass roving in a zig-zag pattern along both edges of adjoining veneers. The application of roving on the veneers is shown schematically in figure 8. This process provides veneers of suitable width for blade fabrication. The roving remains in place during blade fabrication. The effects of roving thickness on veneer bond line thickness was determined to be negligible.

5.2 Shear Web

The shear web piece, shown schematically in figure 6, provides rigidity to the overall blade structure. The shear web was constructed from 4-foot lengths of 1/4-inch thick birch plywood. The individual pieces were bonded into a continuous shear web joined by adhesively bonded scarfed joints. A Douglas fir stringer, constructed from scarfed and overlapped dimension lumber, was used for the bonded interface between the shear web and the tail panels, as shown schematically in figure 9. Between Station 168 and the blade root end

at Station 50, a buildup occurs in the shear web. The purpose of this buildup is to provide a thickened section at the root end to furnish sufficient structural thickness to support the embedded steel load take-off studs. The web buildup was constructed from Douglas fir veneer, as shown in figure 10. The buildup is thickest at the root end and tapers linearly to zero at Station 168. The open root end is capped with 1/4-inch birch plywood. The truncated aft end of the blade is also covered with a bonded 1/4-inch birch plywood tail cap section.

5.3 Afterbody

The afterbody constitutes the trailing edge section of the blade. To develop optimum aeroelastic stability in the Mod-OA wood composite blade, the chordwise center of gravity should be maintained as far forward toward the leading edge as possible. In order to provide a blade design that emphasized a forward center of gravity, a lightweight afterbody was designed. Other design drivers for development of a satisfactory afterbody concept included other considerations as: (1) structural adequacy, (2) acceptable labor, material, and tooling costs, (3) applicability of the afterbody concept for a wide range of blade lengths.

Choices. - Nine different afterbody configurations were investigated. All of the afterbody types were classified under one of three basic configurations, that is, unsupported, partially-supported, and fully-supported. The unsupported afterbody concept was the simplest and least expensive option, but also produced the greatest weight for the amount of buckling resistance offered. All of the unsupported afterbody configurations studied required at least a 3/8-inch thickness of solid wood to provide the necessary strength and stiffness to prevent afterbody buckling near the root.

The trade-off studies (balancing labor and material costs against afterbody weight) showed that a significant amount of weight could be reduced by partially supporting the afterbody panels to increase buckling resistance. Among the options considered for this type of afterbody were: (1) longitudinal stringers with bulk-heads; and (2) periodic ribs made either with laminated wood or with the use of a honeycomb core. Both material and labor costs were found to be unacceptable for the partially-supported afterbody concept.

The fully-supported afterbody concept was studied in detail because this concept offered the best potential for both lightweight and low-cost blade fabrication. All of the fully-supported afterbody options studied required the use of a honeycomb core material to form a sandwich panel up to 1-inch in thickness. Three core materials were evaluated: (1) PVC (polyvinylchloride) foams; (2) balsa wood; and (3) resin-impregnated Kraft paper honeycomb. Both plywood and laminated veneers of various species were considered for construction of the inner and outer skin material for the cored laminate. Because of coring, the use of a high density wood species such as birch for the skins would produce the most structurally efficient afterbody panels.

Full-coring of the entire volume of the afterbody was also considered, but was not practical because of the large section thicknesses involved and the resulting heavier than necessary blade weight. This option did however look promising for the outer blade area where sections are relatively thin.

Selected configurations. - The selected afterbody configuration was a fully-supported cored sandwich section that utilized a resin-impregnated Kraft paper honeycomb core material, with 1/8-inch birch plywood for the inner and outer skin materials. The fully-supported cored afterbody configuration is shown schematically in figure 9. This three-piece laminate was bonded together in the female mold used to fabricate the blade. This configuration was selected because the afterbody could be assembled with reasonable fabrication and labor costs and resulted in the most structurally efficient afterbody at the lowest weight of any of the options studied.

Near the blade tip, the blade thickness becomes thinner and the inner birch plywood sheets become less effective. Therefore, from Station 600 to the tip (Station 750), a fully cored afterbody, shown schematically in figure 11, was selected for blade fabrication. Adoption of full internal coring in the outer blade tip area provided both weight savings and extreme shape rigidity in the blade part that experienced the highest airloads and produced the most energy. The cored panels taper linearly between Stations 500 to 600 so that there was a transition between the fully-supported and the fully-cored portions of the afterbody.

6.0 MATERIALS PROPERTY DATA

Materials used for blade fabrication are described below:

Structure	Material
Nose piece laminate	Sliced Douglas fir veneers
Secondary reinforcing stringers	Douglas fir and spruce dimension lumber
Shear web, outer blade wood surfaces, root end and tip caps	Aircraft grade birch plywood
Outer blade abrasion skin	Fiberglass cloth
Afterbody core material	Phenolic resin-impregnated Kraft paper honeycomb (Verticel brand)
Lightning protection	Aluminum screen
Blade surface protection	Polyurethane paint
Steel load take-off studs	Heat treated and Hardened 4140 Steel
Bonding adhesive	WEST(R) System epoxy resin system

6.1 Wood

The physical and mechanical properties of the materials used for the key blade structures are as follows:

Douglas fir wood species was utilized for the construction of the blade nose laminate structure and has the following nominal properties at 70° F and 12-percent moisture content:

Density	32.6 lb/ft ³
Compression Strength	7 500 lb/in ²
Tension Strength	15 000 lb/in ²
Shear Strength	1 200 lb/in ²
Elastic Modulus	2 x 10 ⁶ lb/in ²

The above values were obtained from reference 7 with corrections for the effect of the epoxy resin content in the laminate veneer structure.

Birch wood species was utilized for blade components where a balance of cross grain to longitudinal grain strength properties are desired, or where installation time could be saved. Significant areas where birch, in the form of plywood, was used, were the outer wood surfaces of the blade and the shear web. Birch has the following nominal properties at 70° F and 12-percent moisture content:

Density	38.7 lb/ft ³
Compression Strength	8 200 lb/in ²
Tension Strength	20 000 lb/in ²
Elastic Modulus	2 x 10 ⁶ lb/in ²

With the exception of tensile strength, the values were obtained from reference 7. The tensile strength parallel to the wood grain was estimated from the modulus of rupture (3-point bend test) strength of 16 000 pounds per inch² and the ratio of tensile strength to modulus of rupture for similar wood species.

Effect of Moisture and Temperature on Wood Properties - Increased moisture and temperature have an adverse effect on the static properties of wood. For an increase in moisture content from 10 to 15-percent, birch and Douglas fir show a 20-percent decrease in strength (ref. 7). In blade construction, the adverse effects of moisture are minimized by the use of epoxy resin coatings that serve as a moisture barrier. The key to successful utilization of wood composite blades, in a variable moisture environment, is to fabricate the blades using wood veneers equilibrated at the average moisture content that the structure will reach in service (about 6-percent for hot and dry climates, and about 12-percent for hot and humid climates), and then seal the entire laminated structure with epoxy resin and paint coatings.

In general, the mechanical properties of wood decrease when heated and increase when cooled. Figure 12 shows the effect of temperature on strength and modulus of elasticity (ref. 7). The variations are expressed for two levels of moisture content as a percentage of values at 68° F. The specific effect of temperature on the wood design properties depends on the local temperature of the critically stressed blade area. For a wind turbine blade stressed in bending, the outer wood fibers are subjected to the greatest loads. These outer fibers are also most likely to be effected by the ambient environment. Data from figure 12 indicate that degradation of strength properties can be severe for a high temperature-humidity environment, as typified by a damp tropical climate. In a desert environment, the low humidity would tend

to counteract the effect of the elevated temperature. For a wood composite blade with a epoxy resin/paint coating, the temperature effect would depend to a large extent on the as-laminated moisture content of the veneers during blade construction since changes in wood moisture are minimized by the epoxy resin barrier coating on inner and outer blade surfaces.

Contract specifications required that the Mod-OA wood composite blades perform adequately up to 120° F. Such temperatures are most likely to occur in desert areas. For such sites, the air is very low in humidity, so that the average, long-term moisture content of the wood will be less than 12-percent. A 12-percent moisture content is more likely at a site near a warm-climate coast, such as the Gulf states or Hawaii, where peak temperatures approach 100° F. This condition, shown in figure 12, also shows the strength degradations resulting from the hot-humid environment should adequately represent a desert site as well (12-percent moisture content and 100° F represent a drop of 0.2 from the reference strength value, and on an interpolated basis, a 6-percent moisture content and 120° F condition represents about the same 0.2 drop in reference strength value).

Fatigue - Cyclic fatigue is a factor which must be considered in the design of wood composite wind turbine blades. Wood is not subject to the kind of fatigue crack propagation common in metals. Wood failure cannot be discussed in terms of yield strength, but rather in terms of fiber crushing or tearing. Also, crack propagation due to stress concentrations has not been found to be a significant problem in wood laminates. Wood is a fibrous material, or a natural composite, and if some fibers are damaged, the load is generally re-distributed to adjacent fibers without causing a high stress concentration problem in the damaged area. Crack propagation is further inhibited in laminated wood composite structures because of the adhesive bond lines that must be crossed.

Fatigue strength for the design of the wood composite blade was estimated from the data in reference 8. This reference presents fatigue data for several wood species in terms of the ratio of stress at fatigue failure to the ultimate modulus of rupture at room temperature (68° F). After correction to ultimate compressive strength (compressive strength is lower in magnitude than the modulus of rupture), it was determined that an appropriate design value of ratio of fatigue stress, at 4×10^6 cycles, to nominal compressive strength for Douglas fir, was 0.3. It was further determined that the strength knockdown factor due to the design environment of 100° F maximum temperature and 12-percent moisture content should be 0.9.

Creep - Creep in wood is another factor which could significantly affect a wood composite blade structure. Wood, like other materials, will continue to deflect or elongate after an initial load has been applied. Creep variations in wood, as obtained from reference 7, are shown in figure 13 for three nominal stress levels. It is seen that the deflection from creep may vary from 0.5 to 1.0 times the initial deflection, with full creep reached after 300 to 400 days.

Creep behavior is approximately the same for all wood species, with creep at low stress levels being similar in bending, tension, or compression parallel to the wood grain. Ordinary environmental variations in temperature and humidity will cause variations in the creep rate. According to reference 7, a

temperature increase of 50° F can result in a two to three-fold increase in creep. The effects of creep are, therefore, a serious consideration in the design of a wood composite blade subjected to a static working load for a long period of time.

The effect of creep caused by blade weight is minimal during normal operation, since blade loading stresses are cyclic and in a given direction for a relatively short time. If the blades are "parked" horizontally and in a feathered condition, one blade would deflect toward the high pressure side, while the opposing blade would deflect toward the low pressure side. This could create an out-of-plane imbalance between blades and increase the centrifugal force component of bending stress when normal operation is resumed. To avoid this problem, the blades will be parked in a vertical position when not in operation, or will be allowed to rotate freely while fully feathered so that all blade orientations will be experienced. While in the vertical position, the out of plane stresses due to weight will be negligible and creep deflection of either blade will be inconsequential.

Creep Rupture - Wood is also subject to creep rupture in which a sustained steady load, lower in magnitude than the static ultimate strength of the wood, can result in failure after an extended period of time. A wood member under a continuous bending load for 10 years can carry only about 60-percent of the load required to produce a single-cycle-to-failure load in the same specimen loaded in a standard bending test (ref. 7). For the assumption of linear variation with time, the fatigue strength of the blade design life of 30 years would be approximately 55-percent of the static value. Thus creep rupture will not be as severe a factor as the cyclic fatigue strength.

6.2 Adhesive

The adhesive used to bond wood veneers, other wood structures, and the load take-off studs into the root-end wood structure was the WEST^(R) System epoxy resin formulated and distributed by the Gougeon Brothers, Inc. The formulation of this epoxy system is proprietary. Basic physical properties of the adhesive are as follows:

Density	71 lb/ft ³
Tensile strength	6 500 lb/in ²
Compressive strength	7 000 lb/in ²
Ultimate elongation	8-9 percent
Elastic modulus	3 x 10 ⁵ lb/in ²
*Shear strength	7 000 lb/in ²

*Ultimate shear strength of the adhesive was not measured, however, a shear strength of 7 000 pounds per inch² was estimated based on measured ultimate tensile and compression strengths and the ultimate shear strength of similar epoxy resins.

Unlike wood, the adhesive is stronger in compression than in tension. The adhesive, therefore, reinforces the wood fiber structure to increase wood compression strength. The adhesive coating also inhibits moisture penetration and helps to protect the wood structure from high moisture content-related effects as well as effects of a salt spray, fungus, and sunlight environments. Furthermore, the adhesive coating on the outer wood composite blade structure

provides a relatively hard surface when used with a surface skin of fiberglass cloth. This same coating provides an aerodynamically smooth finish on the blade surface.

The WEST System (R) epoxy resin adhesive is basically a room temperature cure system. Two types of resin hardeners (types 205 and 206) were used to provide a relatively short, or longer resin cure time, or "pot life". The physical properties of the short and long pot life adhesive formulations are within 10-percent of each other.

Several types of fillers were also used with the adhesive to provide reinforcement, where required. The fillers also change the viscosity of the adhesive formulation by providing a thixotropic consistency that favors minimum flow until curing is completed. The effect of various fillers on adhesive density and elastic modulus is given in Table II.

6.3 Honeycomb Core

The honeycomb material utilized for stiffening the afterbody of the wood composite blade is made from a phenolic resin impregnated Kraft paper. The honeycomb core material is manufactured by the Vertical Co. Properties of this core material are as follows:

Density	1.54 lb/ft ³
Longitudinal shear strength	45.1 lb/in ²
Longitudinal shear modulus	5 840 lb/in ²
Transverse shear strength	15.1 lb/in ²
Transverse shear modulus	1 880 lb/in ²
Compression strength	32.0 lb/in ²

The honeycomb core resists compression and deformation, when bonded between birch plywood panel skins; it increases panel stiffness by resisting movement of the load-carrying blade skins.

6.4 Load Take-Off Studs

The load take-off studs for attachment to the wind turbine hub were specified to be constructed from heat treated SAE 4 140 steel alloy. The result is a high strength stud with good toughness characteristics. Strength values for SAE 4 140, oil quenched alloy are as follows:

Ultimate strength	186 000 lb/in ² , minimum
Yield strength	160 000 lb/in ² , minimum
Rockwell hardness	C40-C42

7.0 KEY COMPONENT TESTS

Performance tests were conducted on specimens that represented the key blade components, i.e. the nose piece laminate, and the hub-to-root end attachment, to verify the selected designs. In addition, tests were conducted to provide design property data for the filler and adhesive combinations described in the section on material properties.

7.1 Nose Piece Laminate

Because the 1/16-inch Douglas fir sliced veneers used for the nose piece laminate (main structural beam member) have a maximum length of approximately 18 feet, lengths of veneer strips having accurately cut edges are butt joined with adhesive to provide the basic veneer material for the blade. Although care is taken to stagger these butt joints throughout the blade, specimens were constructed and tested for static strengths and the effect of butt joint gaps on laminate strengths.

As indicated in the materials property section, the compression strength of the adhesive (7 000 lbs./in²) is about the same as the compression strength of Douglas fir (7 500 lb/in²). The adhesive tensile strength (6 500 lbs./in²) is, however, less than the tensile strength of Douglas fir (15 000 lbs./in²). Tension, therefore, was the critical concern for the butted veneer joints. When loaded in tension, a laminate specimen would fail at the location with the least amount of cross sectional wood fiber. In order to investigate the tensile strength properties of butted joint veneers, specimens were constructed to simulate the most adverse case of 50-percent aligned joints. Two gap widths were studied. A small gap refers to the separation when the veneers are tightly butted, while a large gap refers to a space of 1 to 2 veneer thicknesses between the veneer pieces. In both cases the gaps were filled with adhesive, as was the practice used for blade fabrication. The butt joint specimens were approximately 1-inch by 12-inch in length, and were tested (three replicates) to failure (modulus of rupture) in simple beam bending with a central applied load. A specimen with continuous veneers was used for control purposes.

The test results of the butted and plain specimens indicated that the strength of the 50-percent butt joint specimens was approximately 70-percent of the strength of the control specimens without joints. For a modulus of rupture type of failure, these data implied that the behavior of the butt joined configuration was related to loss in cross-sectional area alone, and that there were no adverse stress concentration effects in the region of the joints. The test data also showed that no significant effects on strength between small and large gap joints.

7.2 Root-to-Hub Attachment

The root-to-hub attachment concept of transferring loads through steel studs embedded into the wood structure is another key structural feature of the blade design. As indicated previously, an extensive testing program was implemented during the blade design phase to develop a satisfactory stud/wood structure system. Details of these stud tests are described and analyzed in reference 5.

A brief summary of the stud development effort to provide ultimate and fatigue strength data is as follows. In the first phase of the stud development program, a number of prototype single-stud test specimens were constructed to define problem areas, explore variables, and establish a baseline test configuration. These stud specimens were typically constructed of a wood block 4-inch by 4-inch by 24-inch long in which a hole was bored in one end of the block. A threaded steel stud was then inserted into the hole, held in alignment, and bonded in place with thickened adhesive. Variables evaluated

included the type of wood construction (solid dimension lumber and sliced veneer laminates), the epoxy resin adhesive/filler system, the stud configuration (length, diameter, taper, type of embedded thread), and the hole configuration (straight sided, linear tapered, and step-tapered).

The experimental evaluation of stud design was supported by theoretical analysis. The critical strength property for the hub attachment is the shear stress in the adhesive generated by the axial load produced by the blade bending moment at the root end of the blade. Adhesive shear stress varies along the length of the embedded stud, with peak values at the end of the stud due to stress concentration effects. A representative value of peak shear stress in the adhesive was computed from a finite-difference computer program developed by the blade contractor. This analysis treated the steel stud and the adhesive as linear elements with variable elasticity. The peak shear calculation was used to select improved stud/hole geometries through balancing of wood and stud stress distributions along the length of the embedded stud.

The baseline stud and block configuration that evolved from these exploratory tests is shown in figure 14. Both the stud and the hole in the wood block were tapered. The stud was embedded into the wood for a length of 15-inch. The steel studs were turned from 2-1/4-inch diameter bar stock to provide a 2-inch diameter threaded section which was directly adapted into the test machine. The laminated wood block was constructed of 1/8-inch Douglas fir veneers, with the wood grain running parallel to the load direction. The wood veneer laminates were trimmed to the 4-inch by 4-inch by 24-inch size. The drilled end of the veneer block was reinforced with a birch plywood cap to provide cross grain strength improvement. Typical stud specimens are shown on figure 15.

A second set of baseline stud specimens (fig. 14) were tested for ultimate load-carrying capability and fatigue properties. These specimens included studs having varying degrees of taper and different embedded thread geometries designed to decrease the adhesive stress concentration. The effects of a mold release (anti-bonding) agent and types of adhesive fillers were also evaluated. The results of this second test phase was a bonded, step-tapered stud design with significantly improved fatigue properties, even when the stud threads were treated with the mold release agent. About 3×10^6 cycles were obtained at a maximum load of 35 000 pounds. An endurance load of up to 28 000 pounds was estimated for the blade design life of 4×10^8 cycles. The improved stud configuration design also sustained a single pull-out load of a minimum of 80 000 pounds. Both the fatigue and pull-out test load capabilities were considered acceptable for the blade design loads.

The stud design concept was also evaluated in a full-scale, 20-foot length wood composite blade section which contained the entire root end with embedded studs. The studs were untapered with 1-inch diameters and 15-inch embedded lengths. The stud shank had 3/4-inch rolled threads on the head portion of the stud. Wood thickness in the root end laminated blade section was 3.0 inch. This blade specimen was subjected to load-deflection tests at NASA Lewis Research Center in the edgewise, flatwise and combined modes. Following these tests, the blade specimen was subjected to fatigue tests at the U. S. Army Research and Technology Laboratory at Ft. Eustis, Virginia. The blade specimen was cantilever mounted with the load applied at the free end. The blade chord was set at 45-degrees to the load in order to approxi-

mate the combined application of flatwise and chordwise design loads. A steady-plus-cyclic loading profile was used. Details of these tests are described in reference 5.

The blade specimen was cycled 1×10^6 cycles, without failure, at loads that produced bending moments ranging from 8×10^4 to 14×10^4 foot-pounds. The respective maximum tensile loads on the studs were approximately 8.6×10^3 to 15.0×10^3 pounds. Failure at a high stress concentration in the steel stud occurred at about 0.7×10^6 cycles with an applied moment of 20×10^4 foot-pounds (21 480 pounds maximum load on the stud). The conclusion from this test of untapered studs was that adequate stress margin should be available for both the 30 year fatigue and the ultimate load (hurricane wind) capabilities to warrant use of the stud attachment concept for construction of full-scale, 60-foot Mod-OA blades.

As a result of the single stud/wood block specimen and the full-scale blade specimen tests, as well as further analysis of peak adhesive shear stress, a final stud design configuration was developed for used in fullscale blade Mod-OA construction. This design stud configuration is shown in figure 16 (and in fig. 6). The tapered stud had a maximum diameter of 1.5 inch at the root and 0.75-inch at the tip. The stud was to be embedded for a length of 15-inch into the wood structure. This configuration was found to produce a lower value of calculated peak adhesive shear stress than any of the stud specimens tested. The root diameter of the stud was maintained at 1.5-inch for about 3-inch in length before tapering linearly to the 0.75-inch diameter at the tip. The hole was to be step-taper drilled about 3/8-inch diameter larger than the stud for increased wood bonding area. To reduce stress concentrations in the adhesive, a modified Acme-type thread with 0.2-inch pitch and 0.1-inch depth was incorporated on the tapered stud section. The thread was started gradually at the root end and did not reach full depth until about 3-inch from the root. The purpose of this transition was to minimize stress concentrations in the steel at the stud root due to rapid changes in area that are encountered in the start of a thread. The bonding adhesive was a mixture of the slow curing resin with asbestos fiber reinforcing filler.

8.0 STRUCTURAL DESIGN ANALYSIS

After feasibility of the key blade components was established and the material properties were defined, a detailed structural analysis of the blade design was conducted. The design process is described in detail in reference 4. The structural design analysis defined the blade loads to be considered, the stresses generated by these loads, and the margin of safety against failure from the generated stresses. The analysis also established the overall structural characteristics of the blade design.

9.0 FINAL BLADE DESIGN

The geometry and dimensions of the final blade design are given in Table I and figure 3. As a result of the analysis of blade stress margins of safety, the thickness of the nose section of the blade was increased along the span. In particular, the thickness of the root section containing the studs was increased from 4.0 to 4.8 inch. The number of the fir veneers was, therefore, increased for the final design. Also, the inner stringer (1 in x 5/8 in) in

the tail panel was extended to the full length of the blade. To compensate for the added weight of these additions, the shear web blocking piece was reduced to a maximum of 2 x 1.5 inch in cross section. An additional stress analysis of the final blade configuration was waived in view of the small changes involved.

The other major change for the final blade design was the use of an intermediate spool piece between the hub spindle and blade root end, as shown in figure 4. This spool piece was necessary because the flange of the wind turbine hub spindle, which was designed to mate with a flange on an aluminum blade (previously designed for use with the Mod-OA wind turbine) was not believed to be sufficiently stiff to permit direct attachment to the wood blade studs.

An overall planform view of the blade design, with the upper half of the blade removed, is shown in figure 17. The figure also shows the various sections of the span that are detailed in succeeding figures. The heavy arrows indicate the stations for which detailed cross sections are presented.

The detailed construction of the individual spanwise sections in figure 17, is shown in figure 18(a) through (e). The light dashed arrows indicate the desired grain direction for the members involved. In general, grain or face grain of all parts were to be oriented longitudinally to the blade unless otherwise specified.

Several blade cross sections are detailed in figure 19(a) through (h). The sections shown in these figures, which are from the lower half of the mold, represent the low-pressure surface of the airfoil. The high-pressure side of the blade is fabricated the same, except that the blade contour differs from the blade contour of the low-pressure side.

A detailed weight analysis was made of the final design blade configuration. The revised calculated weight was 2 430 pounds, compared to the previous estimate of 2 080 pounds. The increase in weight was attributed mainly to the design construction changes mentioned above and to the addition of lightning protection screening. The application of the screening also required the use of a relatively thick layer of thixotropic adhesive to fill the mesh and establish full contact between the outer plywood and the covering fiberglass cloth glass layer.

10.0 COST ANALYSIS

A brief summary of the cost analysis of the wood composite blades, conducted in the design phase of this project, is covered in Appendix A (Section 15.0).

11.0 BLADE FABRICATION PREPARATION

This section includes discussions and descriptions of the blade fabrication procedure, and special tooling requirements.

11.1 Fabrication Procedure

Blade fabrication consists of two major activities involving the preparation of materials and assembly and bonding of these materials into a completed

blade. The assembly and bonding of the materials will be described in the Blade Fabrication section. Material preparation is described below.

Material Preparation - An outline of the material preparation procedures for blade fabrication is as follows:

(1) Veneer Preparation:

- (a) Veneer preparation started by the selection of Douglas fir sliced veneers of adequate quality and trimming to straighten all longitudinal edges. Figure 20 shows a view of the 18-foot length sliced veneers as they were received from the supplier. Note that the veneers have varying widths. Individual veneers were inspected for quality. Any flawed areas, caused by knots and sap-rich regions and etc., were cut out from the veneer. The resulting shorter veneer lengths were, however, utilized for blade fabrication where short length veneers could be used.
- (b) Veneers were "stitched" together to achieve desired mold width (approximately 25-inch at the blade root end). Figures 21 and 22 show side and top views, respectively, of the veneer stitching operation. Note the spools of resin-impregnated fiberglass glass roving on the top of the machine. When two trimmed veneers are passed through the machine (machine feed), the roving is applied on one side of the veneers across the joint in a zig-zag fashion.
- (c) The stitched veneers were trimmed and squared. Trimming is necessary to assure that veneers have square ends for butt joining of veneers during blade fabrication.
- (d) Stitched and trimmed veneers were assembled on the layout table with adequately staggered butt and longitudinal joints. The veneer layers, including individual pieces in a given layer, were assigned sequential serial numbers to aid in blade construction. Figure 23 is a view of the veneer layout table showing an assembly of veneers in a "lift". This particular view shows a lift that was used for the construction of the thickened shear web. Note the "drop-off" of the veneer lengths along the structure to provide the design thickness variation of the structure.
- (e) Final trimming of one edge of layout veneer pile was performed. The trimmed edges of individual veneers were positioned into the female mold against the shear web.
- (f) Final inspection was made of veneer lifts before adhesive coating. This inspection included assurance that all of the veneers were present in their design lengths, and were in proper sequence for application of adhesive and installation into the female blade mold.

(2) Plywood preparation

- (a) The 1/8-inch birch plywood pieces for the nose laminate outer surfaces were cut to size.

- (b) The 1/8-inch birch plywood pieces for tail panel assemblies were cut to size, edges were scarfed, and the plywood pieces were adhesively bonded in to full length panels.
 - (c) The 1/4-inch birch plywood section for the shear web were cut to size and the ends were scarfed. These scarfed pieces were bonded together in to a continuous shear web as individual pieces were fitted and positioned into the female blade mold.
- (3) Wood stock preparation
- (a) The Douglas fir dimension lumber for root end build-up were cut to size.
 - (b) Joining cleats for the shear web were cut to required dimensions and the ends of the pieces were scarfed.
 - (c) The Sitka spruce dimension lumber for the trailing edge stringer was cut to size.
 - (d) The Douglas fir dimension lumber stock for stringers aft of the shear web was cut to size.
- (4) Honeycomb core material preparation
- (a) Precutting of the 3/4-inch thick honeycomb core material to fit in the tail panel areas was conducted. These pieces of honeycomb were sandwiched between two pieces of 1/8-inch birch plywood during blade construction.
 - (b) The 3-inch thick honeycomb core material for the outer solid-cored tail area were precut. These honeycomb pieces were assembled into the blade mold over the birch plywood at the outer blade area. The excess core material thicknesses were cut to the required thickness during the band sawing operation.
- (5) Preparation of fiberglass cloth and aluminum screening
- (a) Precutting and fitting of the layers of 10-ounce fiberglass cloth to size was conducted. This material was cut to fit the mold in a continuous piece from root end to the blade tip.
 - (b) Precutting and fitting of the 14 mesh aluminum lightning protection screening was conducted. The screening was cut into one continuous piece that extended from the blade root end to the tip.

11.2 Special Tooling

Blade Fabrication Molds - Male molds, representing both high and low pressure sides of a blade were fabricated from sawn lumber and plywood. The surfaces of the male molds were made of plaster over a wood framework. The plaster surface was accurately contoured to the required airfoil surfaces by the use of full scale blade chord templates. The mold surfaces were then optically checked for correct alignment and blade twist. The mold surfaces were then

coated with adhesive. After curing of the adhesive was completed, a mold release agent was applied to the mold surfaces. Figure 24 shows one of the completed male molds.

The female molds were fabricated upside down on the male molds as follows:

1. Fiberglass cloth was cut and applied to the male mold surfaces and coated with adhesive. The application of the fiberglass cloth to the mold is shown in figure 25 (a).
2. This was followed by an adhesive-coated paper honeycomb core material, and a plywood skin that served as the mold backing. The core and plywood components were adhesively bonded to the fiberglass cloth, and to each other by vacuum bag compaction.
3. After curing was completed, plywood ribs, longitudinal stiffening members, and supporting legs and braces were bonded to the plywood backing, as shown in figure 25 (b), and (c).
4. After completion of adhesive curing, the female molds were lifted off the male molds and placed into position on the shop floor where the blades would be fabricated.
5. The female molds were optically aligned, leveled, and the legs were bonded into place on the shop floor.
6. Finishing operations included the installation of vacuum piping, guide tracks for the band saw, and application of a mold release agent on the mold surfaces. Figure 25 (d) shows the final finishing operations.

Vacuum pump and manifold - An 85 foot³ per minutes vacuum pump was installed to provide a vacuum source and associated piping to evacuate both female molds simultaneously.

Veneer "stitching" machine - Figures 21 and 22 show views of a machine to "stitch" two veneers in a longitudinal fashion by applying a resin-impregnated fiberglass roving in a zig-zag pattern over the veneers. This machine could stitch veneers at a rate up to 90 feet per minute

Adhesive application machine - Figure 26 shows a view of the adhesive application machine that provided a uniform thickness of adhesive on both sides of the veneers (as well as the 3/4-inch thick honeycomb core material used for afterbody construction). Adhesive thickness was controlled by a micrometer adjusted spreader blade that applied adhesive to two rubber rolls. The rolls, in turn, transferred adhesive to the veneer surfaces as the veneers were fed into the machine. The machine had the capability of handling materials having widths up to 26-inch. A goal of about 40 pounds of adhesive was applied per 1000 square foot of veneers used for construction of the blades described in this report. The adhesive thickness, after curing, ranged from 0.003 to 0.010-inch.

Stud hole drilling and attachment fixture - A fixture, for drilling of holes in the root-end wood structure of the blade, and for insertion of steel load take-off studs into the holes, is shown in figure 27. The fixture was

equipped to index the face plate to provide accurate drilling of the 24 stud holes. The holes on the opposite side of the face plate of the fixture have a chamfered surface. Tapered nuts that mated with the chamfered surfaces were used to fasten the threaded stud shanks to the face plate for insertion and bonding of the studs into the drilled holes.

Band saw - A specially designed band saw, shown in figure 28, was used to trim each blade half-shell in one continuous operation. During the half-shell trimming operation, the band saw was placed on guide tracks built into the female molds.

12.0 BLADE FABRICATION

This section describes the major steps involved in blade fabrication. Included in this section are descriptions of material loading into the female molds, blade half-shell trimming, assembly of the two half-shells into a blade root end and tip close-outs, insertion of load take-off studs, and blade competition. The blade fabrication was performed in accordance with the detailed blade design drawings shown on figures 17, 18 (a) through (e), and 19 (a) through (h).

12.1 Material Loading into Female Molds

Fabrication of the blades started by the application of a white pigmented adhesive coating (0.004-inch thick) to the mold surfaces (previously treated with a mold release agent). Precut fiberglass cloth was then inserted into the molds, as shown schematically in figure 29. After the fiberglass was smoothly formed over the adhesive coated mold surfaces, additional adhesive was applied to impregnate the cloth. This was followed by insertion into the mold the precut aluminum lighting protection screening. Additional adhesive was then applied to coat the screening.

Next the preassembled outer birch plywood afterbody panel, equipped with the longitudinal shear web stringer, was inserted into the mold and temporarily stapled into place as shown in figure 29 (to prevent movement of the panel assembly during subsequent vacuum bag compaction pressure). The outer birch plywood panel was fabricated as a subassembly on a layout table. The panel was fabricated from adhesively-bonded 4-foot lengths of 1/8-inch plywood that had scarfed joints. Figure 30 shows a view of the afterbody panel subassembly under construction.

This was followed by two 1/16-inch birch plywood outer nose plies that were butt joined to the 1/8-inch outer birch plywood afterbody panel, as shown schematically in figure 29. The remainder of the afterbody components, such as the sawn lumber frames, the 3/4-inch honeycomb core material, and the 1/8-inch inner birch plywood face panels (fabricated as a preassembly on a layout table), were then assembled into place on the outer afterbody panel already in the mold. All component parts were coated with adhesive prior to insertion into the mold. Figure 31 shows a view of the assembly of the honeycomb core material on the outer afterbody panel. The technicians on the left of the figure were applying adhesive to one face of the inner birch plywood face panel subassembly. The adhesive application machine can be seen positioned in front of the blade molds in the foreground of figure 31.

All of the blade assembly completed thus far was then vacuum bag compacted and the adhesive was allowed to cure (typ. 10-12 hr). After curing was completed, the vacuum bag was removed, and blade construction was continued by assembly of the shear web.

The shear web was constructed from 4-foot lengths of 1/4-inch birch plywood precut into varying widths. The ends of the 4-foot section were scarfed. Thickened adhesive was applied to the face of the longitudinal stringer on the afterbody outer panel skin. Individual shear web pieces were then positioned onto the stringer face, and held in place against the adhesive coated stringer with plastic staples. The scarfed joints were coated with unfilled adhesive as the pieces were joined together to form the full length shear web. Longitudinal cleats (fig. 42) made from sawn and scarfed lumber were then bonded to both sides of the shear web tops to provide a wide shear area for subsequent bonding of the shear web sections from both blade half-shells. Figure 32 shows a view of the bonding of the cleats to the top of the shear web. Spring clamps were used to apply pressure to the cleats during adhesive curing. This view also shows a technician stapling (plastic staples) through the scarfed joints on the shear web to apply pressure to the scarfed joints during adhesive curing.

Layers of Douglas fir veneers were then bonded to the shear web starting from Station 168 to the root end at Station 50 to provide a thickened wood structure for drilling and bonding of the load take-off studs at the blade root-end. The thickness of the shear web build-up varies from 1/4-inch at Station 168 to 4.5-inch at Station 50. Figure 33 shows a view of the shear web buildup.

The next phase of blade fabrication involved the insertion of the nose laminate veneers into the mold. An assembly or "lift" of precut and assembled veneers was positioned in front of the adhesive application machine, with the outermost veneer on top of the lift. All veneer layers and individual pieces of a given layer were previously identified to assure that all pieces would be assembled in correct order. Individual veneers were passed through the adhesive application machine and about 40 pounds of adhesive per 1 000 square foot of veneer surface was applied to the veneers. Figure 26 shows a view of a veneer being coated with adhesive. The adhesive-coated veneer pieces were inserted into the mold against a fixturing stop at the blade root end, and against the shear web. Thickened adhesive was applied to each veneer butt joint. Veneer lengths were designed to assure that butt joints on adjacent plies would be spaced a minimum of 6-inch. Thickened adhesive was also applied to the shear web surfaces as veneers were added to the mold. Figure 34 shows a view of the nose laminates after insertion into the mold and before vacuum bag compaction. This view also shows the shear web veneer buildup that was previously installed.

After completion of insertion of the nose veneers into the mold (total elapsed time of about 1 to 1.5 hours in order to stay within the "pot life" of the adhesive), a vacuum bag was installed over the entire blade assembly completed thus far. The adhesive was allowed to cure under vacuum compaction pressure. Figure 35 schematically shows the installation of the vacuum bag over the blade components, and how the bag was sealed around the periphery of the mold. In this view, the afterbody and the two 1/16-inch birch skins had been installed and cured in a previous step.

After completion of adhesive curing, the vacuum bag was removed and an inspection of the lamination was made. Figure 36 shows a view of the root-end part of the blade after removal of the vacuum bag. Note that the rough ends of the veneers protrude above the mold top (these were trimmed in a subsequent step). An inspection was made of the lamination to assure that the nose laminate/shear web interface was adequately bonded. Additional adhesive was applied, where necessary, to fill any gaps. The remaining blade components, such as triangular root-end veneer buildup at the shear web/nose laminate junctions, and the blade tip honeycomb core material were bonded into place.

12.2 Blade Half-shell Trimming

After installation and bonding of the blade components was completed, the band saw was set on guide tracks positioned at the outer perimeter of the mold. The blade half-shell was then trimmed in one continuous pass of the saw (about 1.5 hr). Figure 37 shows a view of the band saw in operation at about the blade mid-span. Note that the nose piece laminate, shear web, and afterbody were trimmed in one operation. Figure 38 shows the trimming of the honeycomb core near the blade tip. After completion of trimming, the cut surfaces were inspected for flatness. Minor ripples in the wood surfaces caused by saw blade chatter, were removed by hand planing.

The Station 168 rib (constructed from 1/4-inch birch plywood) was next installed in each blade half-shell. The installation of the rib is shown in figures 39 and 40. Note that figure 39 shows the bonding of sawn lumber cleats on the top of the rib.

12.3 Blade Assembly

After both half-shells were completed, preparations were made to bond the two half-shells into a blade. This operation is shown schematically in figures 41 and 42. Figures 41 and 42 show views at the root end and mid-span blade sections, respectively. Figure 43 shows one of the completed half-shells being lifted out of its mold. This half-shell was inverted and placed on wood beams and moved towards the other half-shell. Figure 44 shows a view of one of the half-shells suspended over the other half-shell still in its mold. The two half-shells were then "dry" fitted to each other to assure that all surfaces to be bonded would accurately contact each other. After completion of dry fitting, the upper half-shell was lifted away from the bottom half-shell a sufficient distance to allow the application of unfilled priming adhesive to all surfaces to be bonded. The priming adhesive was applied to all faying surfaces to fill in wood pores prior to application of thickened adhesive. Thickened adhesive was then applied to all faying surfaces on the bottom half-shell. The upper half-shell was then brought into contact with the lower half-shell. The two half shells were fixtured to prevent movement of the top half-shell during adhesive curing. Weights were applied to the top half-shell during curing to provide adequate flow of the adhesive to assure that all gaps were filled and that the bonding operation would be successful.

12.4 Root-End and Tip Close-Out

After completion of bonding of the two half-shells, the blade was lifted from its mold and prepared for completion. The blade root-end and tips were rough trimmed, as shown in figures 45 and 46, respectively. The blade root-

end was finish trimmed by means of a router attached to the face plate of the drilling fixture. Figure 47 shows a view of the finish-trimmed root-end. The view shows the technicians applying adhesive to the surface prior to bonding of a 1/4-inch birch plywood cap.

The blade tips were accurately trimmed, and wood blocking was installed. Afterwards, 1/4-inch birch plywood caps were bonded into place. Holes were drilled into the caps and blocking and release agent-coated threaded metal rods were cast in the holes using thickened adhesive. Afterwards the rods were removed and replaced with fiberglass bolts. The threaded holes were provided for the addition of tip tuning weights.

12.5 Insertion of Load Take-off Studs

As stated previously, the drilling fixture was used for stud hole drilling, root-end finishing, as well as positioning of the studs for bonding into the blade structure. The drilling fixture was accurately positioned with respect to the blade. The blade was also anchored to prevent movement during drilling and stud insertion. This drilling fixture and blade orientation procedure provided assurance that both blades would be in the correct orientation with respect to the design blade angle settings. Figure 48 schematically shows the drilling fixture set up for hole drilling. Figure 49 shows a view of the drilling motor installed on the face plate of the drilling fixture. As stated previously, the fixture was equipped with a face plate that could be indexed for drilling of the 24 holes. Figure 50 shows a view of the step-tapered drill prior to drilling of the first hole. Figure 51 shows a view after completion of hole drilling.

After drilling of the 24 holes was completed, a stud spacing fixture, made of 1/8-inch birch plywood was positioned on the drilling fixture face plate. This spacing fixture, shown in figure 52, was equipped with 24 holes slightly larger in diameter than the stud shoulders. Each hole was equipped with a 0.001-inch Mylar film diaphragm that was slit to allow the stud shanks to pass through the face plates holes. The purpose of the spacing fixture was to allow an 1/8-inch protrusion of the stud shoulders from the root-end birch plywood cap after bonding of the studs. The Mylar film diaphragms would provide a smooth adhesive fillet at each stud shoulder and prevent the flow of adhesive on the stud shanks. The 24 load take-off studs were attached to the drilling fixture face plate (treated with mold release agent) with centering nuts that mated with chamfered surfaces machined on the holes on the opposite side of the face plate. The flatness of the face plate was critical since it was necessary to provide accuracy of adjacent stud faces to within +/- 0.001-inch of lying in the same plane. This was the most critical tolerance for blade construction. Inaccuracies greater than about 0.001-inch between faces of adjacent studs could result in an overload of the epoxy resin adhesive stud bonds, early fatigue failure of the adhesive bond in the wood structure, or early fatigue failure of the stud shanks.

After completion of a "dry" fit of the studs into the drilled holes, the holes were prime coated with unfilled adhesive to fill the wood pores, as shown in figure 53. Afterwards, calculated quantities of thickened adhesive were added to each hole, as shown in figure 54. Care was taken to assure that no air pockets were formed during the addition of adhesive in the holes. Thickened adhesive was also applied to the modified Acme-type threads that would

be bonded into the drilled holes, as shown in figure 55. The studs, positioned on the face plate, were then slowly inserted into the holes (fig. 56) causing voids to be displaced by excess adhesive. The face plate of the drilling fixture (with its spacing fixture) was brought into full contact with the birch plywood root-end cap until the adhesive was cured. Afterwards, the stud nuts, and the drilling fixture were removed to expose the shanks on the embedded studs and provide an opportunity to inspect the completion of cure and accuracy of stud alignment.

12.6 Blade Completion

Operations to complete the blade included outer blade finishing and painting, serial numbering, attachment of the root end lightning protection grounding strap, and final blade weighing, and measurement of blade center of gravity. After completion of the second blade, weight and center of gravity measurements were also made. The weight of the two blades were 2 470 and 2 603 pounds with a center of gravity approximately 224 in from the root end of the blades. Figure 57 shows a view of the ballasting process for the addition of thickened and weighted adhesive to the lighter of the two blades in order to achieve an accurate match of weight and center of gravity. Note that figure 57 shows that the birch plywood cap on the root-end was drilled out for the insertion of the adhesive into the blade. After completion of the blade ballasting, the plywood cap was resealed.

After completion of final blade inspection, the blades were installed in a plywood container (fig. 58) for shipment to Hawaii. Upon arrival at Hawaii, the trailing edges of both blades were found to be split. The damage was caused when the blades were subjected to an internal pressure build-up during shipment over the Rockies. The blades were constructed and hermetically sealed at a low elevation at GBI and experienced a significantly lower external pressure during the time that splitting occurred. The blades were successfully repaired and a venting system was installed on each blade.

13.0 QUALITY ASSURANCE AND INSPECTIONS

To assure that the wood composite blades meet all specifications, a quality assurance program was implemented during all phases of material preparation and blade fabrication. The quality assurance program, in general, included the following:

- (1) Specifications and inspections of materials,
- (2) Written procedures for critical phases of blade fabrication,
- (3) Inspection of blades during fabrication.

Prior to blade fabrication, materials of adequate quality and properties were specified and procured. The wood veneers and dimensional lumber stock were inspected for correct species, and acceptable moisture content. The adhesive components were certified chemically prior to acceptance, and dated so that shelf life would not be exceeded. The resin and hardener components of the adhesive were color toned so that mixed adhesive could be visually discerned from unmixed resin or either adhesive component. Other adhesive ingredients such as fillers and additives in the uncured adhesive were certified by the original manufacturers that the materials complied with all procurement specifications.

The steel load take-off studs were inspected for compliance with design specifications and drawings. These inspections were made at all phases of stud manufacturing. The completed studs received an extensive inspection for dimensional accuracy, and for cracks and inclusions by dye penetrant and ultrasonic testing. The stud supplier was requested to certify that the studs complied with all drawing specifications.

During blade fabrication, particularly blade molding, there were many opportunities to inspect blade quality. Tolerances for shape and twist were controlled by the molds, therefore the male molds that were used to construct the female molds were extensively checked for correct airfoil shape, twist, and other key design requirements. During blade molding, quality control inspections were performed by both contractor and NASA-LeRC personnel for all key fabrication phases. After each vacuum bag compaction process, the exposed wood joints were inspected for flaws, gaps, or resin-poor areas. Before gaps were filled with adhesive in key areas, investigation of possible hidden void-ridden areas were checked by using small probes or drilling along a suspect joint. After inspection, the voids, along with any drilled areas, were filled with adhesive.

The final quality assurance technique was to insure that all components and operations were accomplished and checked prior to commencement of the next fabrication step. Written detailed procedures were prepared for key fabrication operations.

The effectiveness of the quality assurance program, implemented for blade fabrication, was checked upon removal of the Hawaii wood composite blades from service after eighteen months (nearly 8 000 hr) of continuous, high power (average 150 kW) service. The blades were removed from service because one of the stud shanks fractured due to stress-corrosion fatigue. The stud failure was caused by a lack of complete contact of the stud face with its mating wind turbine spool piece. Although the stud shanks and faces were protected from the marine environment by liberal application of petroleum grease, the moist salt air penetrated the protective film and caused pitting of the stud face.

The stud shank failure was attributed to lack of full contact of the stud face with the face of the spool piece flange. Lack of full contact was caused by the stud being a slightly tipped out of true position when the stud was bonded into the blade structure. The stud shanks and faces on the remaining studs on the blade, with the exception of four studs that indicated signs of corrosion, were in their original polished condition. The inspection also showed that the remainder of the blade components, including the wood composite structure, were in excellent condition.

A chemical analysis of the stud shank disclosed that the stud supplier provided 41L40 alloy rather than the specified 4 140 alloy. It is not certain if the lead-containing alloy contributed to the corrosion problem. The substituted alloy does, however, have 10-percent lower strength and fatigue properties than the specified alloy.

The failed stud, as well as the four questionable studs, were "cored-out" by the use of a special drilling fixture. Five new replacement studs (4 140 alloy) were successfully inserted and bonded into the blade wood structure. The blade is currently in a service-ready condition.

14.0 CONCLUSIONS AND CONCLUDING REMARKS

Conclusions derived from the design and fabrication process and experience described in this report are as follows:

1. The wood composite Mod-OA blade design and fabrication process developed in this project can provide blades having an excellent low cost potential.
2. Both the estimated and actual fabrication costs of the wood composite Mod-OA blades are significantly less than the cost of the original Mod-OA aluminum blades.
3. Unique tooling was developed for fabrication and cutting of blade half-shells, and for stud hole drilling and stud insertion.
4. The adequacy of the wood blade design and fabrication process was indicated by inspection of the wood structure of the Hawaii wood composite blades after a continuous, high power operational period of eighteen months (nearly 8 000 hr).

The development of the blade fabrication procedure has indicated that greater precision in stud placement is needed to preclude mis-alignment of stud faces and stud axes. The inspection of the Hawaii blades indicated that corrosion is minimized when stud face contact with the mating spool piece flange approaches a metal to metal contact condition.

In general, it is believed that, within the constraints of time and funding available, the prototype blade design and fabrication effort described in this report was, for the most part, extremely successful. The project demonstrated the adequacy of the basic blade design and fabrication procedure for constructing a low-cost, wood composite blade for Mod-OA service.

APPENDIX A

15.0 WOOD COMPOSITE BLADE COST ANALYSIS

This section summarizes the cost analysis of wood composite blades conducted during the design phase of this project.

15.1 Cost Data

The blade cost data presented in this Section contain two general types of information. The first is the estimated costs for large-quantity production initially generated by the blade manufacturer during the design of the Mod-OA wood composite blades. These data are then updated with cost data from laminated wood composite blades that have been designed and/or fabricated since that time.

15.2 Mod-OA Blades

Cost estimates were made for the 100th and 1 000th blade of the Mod-OA wood composite design. These estimates were based on 1977 dollars, as required by the contract. Blade costs were determined for production rates of 120 and

960 blades per year. These cost estimates were based on the construction of a new blade construction plant. The plant is designed around a basic manufacturing module shown schematically in figure 59(a). This basic manufacturing module is capable of producing 120 blades per year on a one-shift basis, and 240 blades per year with two shifts. Increased production to 960 blades per year (two shifts) would then be obtained through the addition of a similar manufacturing module, as shown in figure 59(b). Plant location was assumed to be 30 to 50 miles north of Bay City, MI to tap a basically agrarian labor market.

The details of the blade cost and analysis conducted during the design phase of this project are given in Appendix A of reference 4. The referenced analysis provides an estimated cost of \$4.33 per pound of blade weight for the 100th blade, and 2.81 per pound for the 1 000th blade in 1977 dollars.

Estimated blade costs were projected to current years based on a fixed blade design and materials specification, but with improvements in labor utilization, construction methods, material selection, and purchasing. Based on Appendix A of reference 4, the Mod-OA wood composite blade cost per pound in 1982 dollars was projected to increase to approximately \$6.20 to \$7.80 for the 100th blade (absolute cost, \$14 900 to \$18 700 for a 2 400 pounds blade). For the 1 000th blade, the unit cost in 1982 dollars is about \$4.00 to \$5.00 per pound.

Three additional sets of Mod-OA wood composite blades were fabricated since the completion of the first set of Mod-OA blades. The average purchase price was \$45 000 per blade in 1980 dollars, or about \$18.80 per pound. The original Mod-OA aluminum blades cost approximately \$200 000 each. However, both of these examples are prototype or single-item fabrication runs, which are more costly than large-production runs. The \$18.80 per pound actual cost for the prototype wood composite blades constructed for the Mod-OA wind turbine program compares to an estimated cost of \$5.40 to \$6.20 in 1980 dollars for a production rate of 100 blades per year.

16.0 REFERENCES

1. Linscott, B. S.; and Shaltens, R. K.; and Eggers, A.G.: Aluminum Blade Development for the Mod-OA 200-kW Wind Turbine. DOE/NASA/20370-20, NASA TM-82594, Dec. 1981.
2. Linscott, B. S.; Shaltens; R. K.; and Eggers, A. G.: Test Experience with Aluminum Blades on the Mod-OA 200-kW Wind Turbine at Clayton, New Mexico, DOE/NASA/20370-21, NASA TM-82595, Dec. 1981.
3. Gougeon, M.; and Zuteck, M.: The Use of Wood for Wind Turbine Blade Construction. Large Wind Turbine Design Characteristics and R&D Requirements, S. Lieblein, Ed., NASA CP-2106, CONF-7904111, 1979, pp. 293-308.
4. Lieblein, S.; Gougeon, M.; Thomas G. and Zuteck, M.: Design and Evaluation of Low-Cost Laminated Wood Composite Blades for Intermediate Size Wind Turbines: Blade Design, Fabrication Concept, and Cost Analysis. DOE/NASA/0101-1, NASA CR-165463, December 1982.

5. Faddoul, J.: Test Evaluation of a Laminated Wood Wind Turbine Blade Concept. DOE/NASA/20320-30, NASA TM-81719, May 1981.
6. Bankaitis, H.: Evaluation of Lightning Accomodation Systems for Wind-Driven Turbine Rotors. DOE/NASA/20320-37, NASA TM-82784, Mar. 1982.
7. Wood Handbook-Wood as an Engineering Material. Forest Products Laboratory, Forest Service, U. S. Dept. of Agriculture, Agriculture Handbook No. 72, Aug. 1974.
8. Kommers, W. J.: The Fatigue Behavior of Wood and Plywood Subjected to Repeated and Reversed Bending Stresses, Forest Products Laboratory, Forest Service, U. S. Dept. of Agriculture, No. 1327, 1943.
9. Spera, D.: Comparison of Computer Codes for Calculating Dynamic Loads in Wind Turbines. DOE/NASA/1028-78/16, NASA TM-73773, 1977.

TABLE I. - MOD-OA WOOD COMPOSITE BLADE GEOMETRY

Station	Chord length, (in)	Maximum thickness, (in)	Thickness/ chord length, (%)	Twist, (°)
50	22.5	22.25	----	0
120	47.5	20.9	----	0
168	62.4	19.8	31.7	0
318	52.8	15.3	29.0	0.6
418	46.4	12.3	26.5	1.0
518	40.0	9.3	23.3	1.7
618	33.6	6.3	18.7	2.6
718	27.2	3.3	12.1	3.9
750	24.0	1.8	7.5	4.8

TABLE II. - PROPERTIES OF WEST SYSTEM ADHESIVE VARIOUS HARDENERS AND FILLERS

Hardener type	Filler type	Density lb/ft ³	Elastic modulus, lb/ft ²	Specific modulus ft ³ /in ² ^a
205	None	71.0	327 000	4,610
	Asbestos	69.5	350 000	5,040
	Colodial silica	63.6	260 000	4,090
	Microballoons	39.0	147 000	3,770
	Microspheres	38.2	208 000	5,450
	1/8-inch graphite fibers	60.9	549 000	9,020
	1/4-inch graphite fibers	63.2	454 000	7,180
	Graphite fiber mat	59.5	527 000	8,860
206	None	73.8	296 000	4,010
206	Asbestos	72.2	333 000	4,610
206	Microspheres	39.7	166 000	4,180

^aSpecific modulus is defined as the ratio of modulus to density

ORIGINAL PAGE IS
OF POOR QUALITY



Figure 1. - DOE/NASA experimental MOD-OA wind turbine, Kahuku, Hawaii.

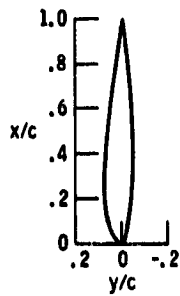

NACA 23012

(Stations and ordinates given in percent of airfoil chord)

Upper surface		Lower surface	
Station	Ordinate	Station	Ordinate
0	-----	0	0
1.25	2.67	1.25	-1.3
2.5	3.61	2.5	-1.71
5.0	4.91	5.0	-2.26
7.5	5.80	7.5	-2.61
10	6.43	10	-2.92
15	7.19	15	-3.50
20	7.50	20	-3.97
25	7.60	25	-4.28
30	7.55	30	-4.46
40	7.14	40	-4.48
50	6.41	50	-4.17
60	5.47	60	-3.67
70	4.36	70	-3.00
80	3.08	80	-2.16
90	1.68	90	-1.23
95	.92	95	-.70
100	(.13)	100	(-.13)
100	-----	100	0

L. E. radius: 1.58
Slope of radius through L. E.: 0.305

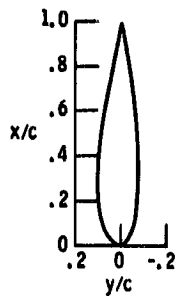

NACA 23018

(Stations and ordinates given in percent of airfoil chord)

Upper surface		Lower surface	
Station	Ordinate	Station	Ordinate
0	-----	0	0
2.5	4.09	1.25	-1.83
5.0	5.29	2.5	-2.71
7.5	6.92	5.0	-3.80
10	8.83	7.5	-4.00
15	9.86	10	-5.22
20	10.36	15	-6.18
25	10.56	20	-6.86
30	10.55	25	-7.27
40	10.04	30	-7.47
50	9.05	40	-7.37
60	7.73	50	-6.81
70	6.18	60	-5.94
80	4.40	70	-4.82
90	2.39	80	-3.48
95	1.32	90	-1.94
100	(.19)	95	1.09
100	-----	100	(-.19)
100	-----	100	0

L. E. radius: 3.56
Slope of radius through L. E.: 0.305

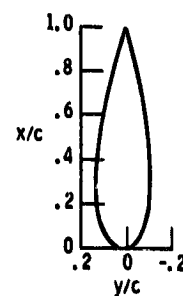

NACA 23024

(Stations and ordinates given in percent of airfoil chord)

Upper surface		Lower surface	
Station	Ordinate	Station	Ordinate
0	0	0	0
.277	4.017	2.223	-3.303
1.331	5.764	3.669	-4.432
3.853	8.172	6.147	-5.862
6.601	9.884	8.399	-6.860
9.423	11.049	10.577	-7.647
15.001	12.528	14.999	-8.852
20.253	13.237	19.747	-9.701
25.262	13.535	24.738	-10.223
30.265	13.546	29.735	-10.454
40.256	12.923	39.744	-10.278
50.235	11.590	49.766	-9.482
60.202	10.008	59.798	-8.242
70.162	7.988	69.838	-6.664
80.116	5.687	79.884	-4.803
90.064	3.115	89.936	-2.673
95.036	1.724	94.984	-1.304
100	-----	100	0

L. E. radius: 6.33
Slope of radius through L. E.: 0.305

Figure 2. - NACA 230-Series airfoils.

ORIGINAL PAGE IS
OF POOR QUALITY

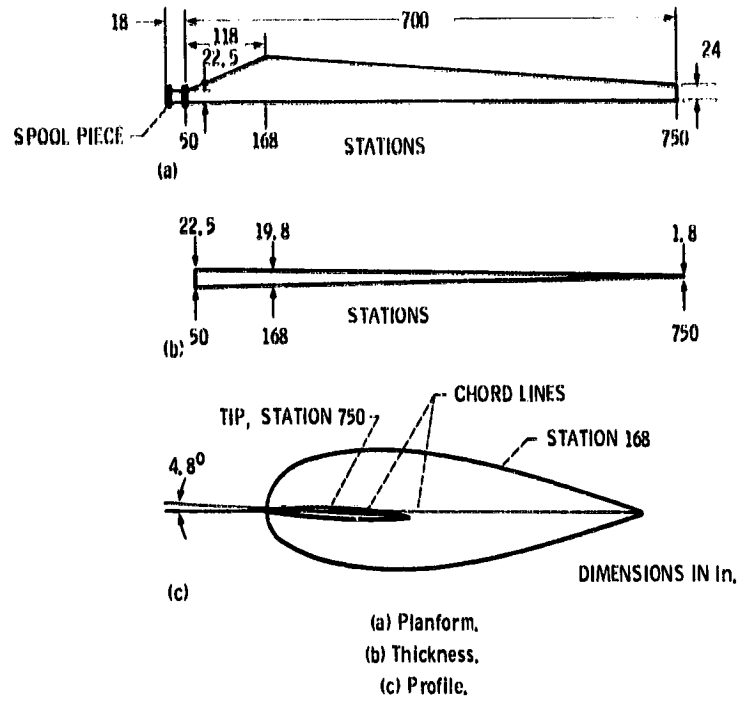

Figure 3. - External geometry of mod-oa wood composite blade.

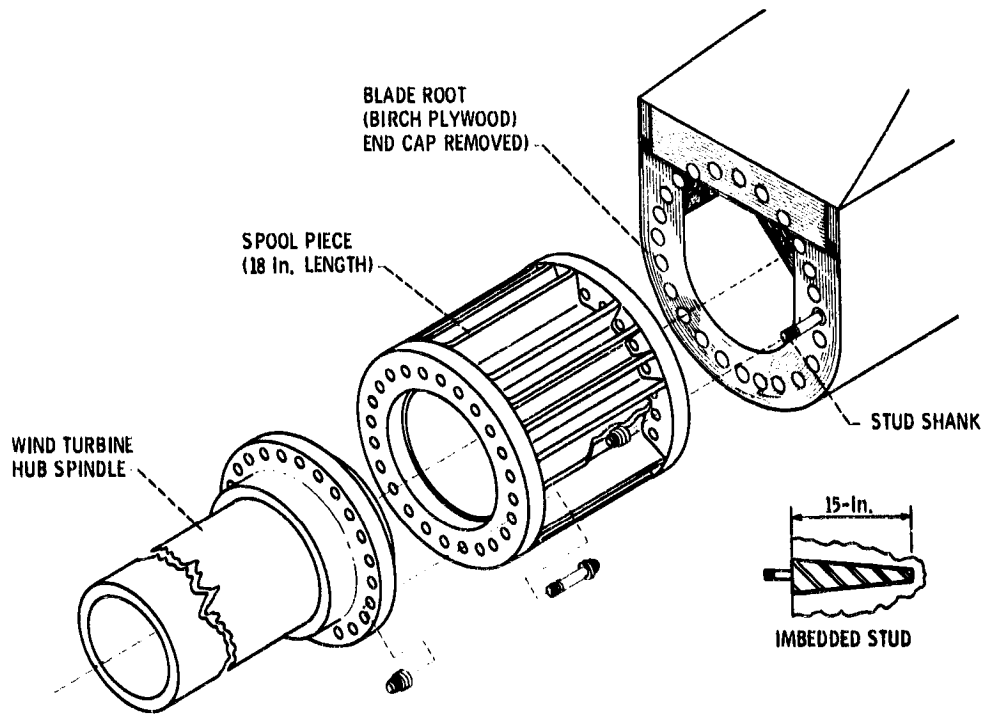

Figure 4. - Schematic of hub attachment for wood composite blade.

ORIGINAL PAGE IS
OF POOR QUALITY

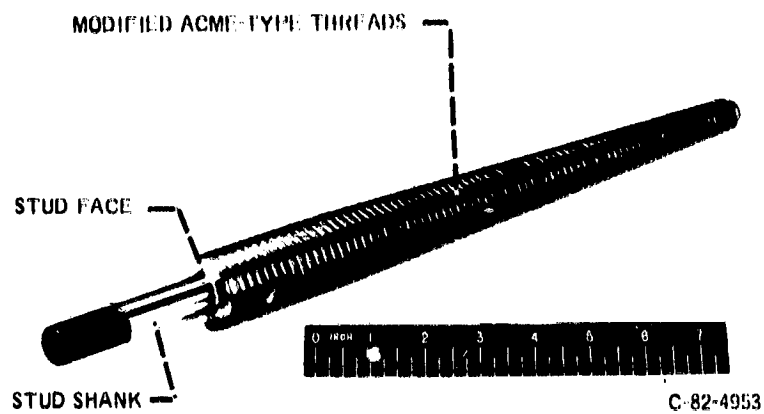

Figure 5. - MOD-OA steel load take-off stud.

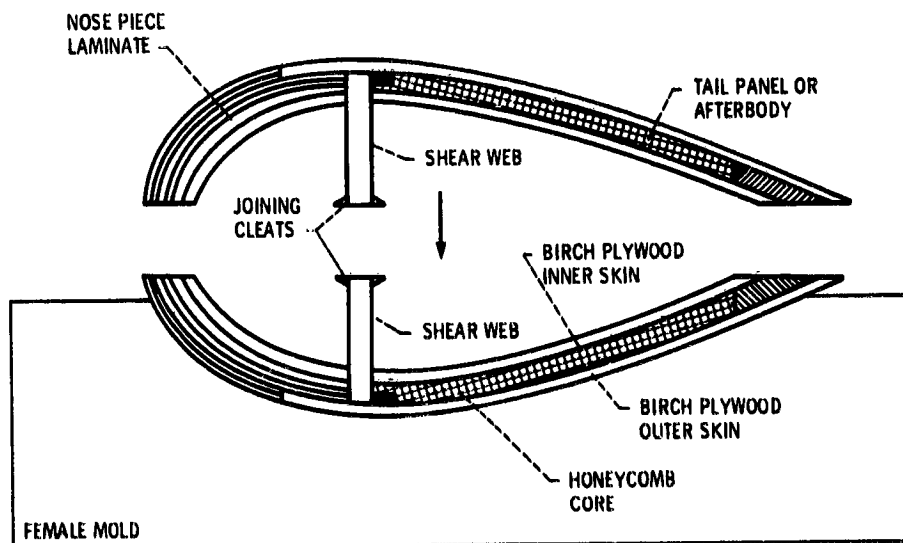

Figure 6. - Schematic of two-part half-shell mold.

ORIGINAL PAGE IS
OF POOR QUALITY

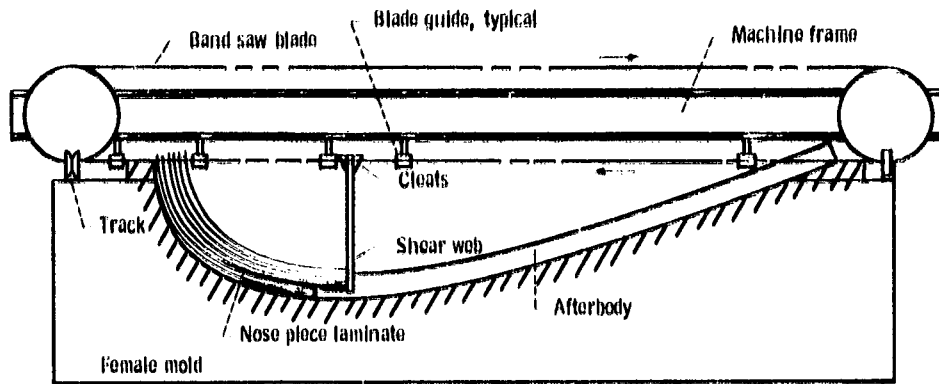

Figure 7. - Band saw concept for cutting blade half-shells.

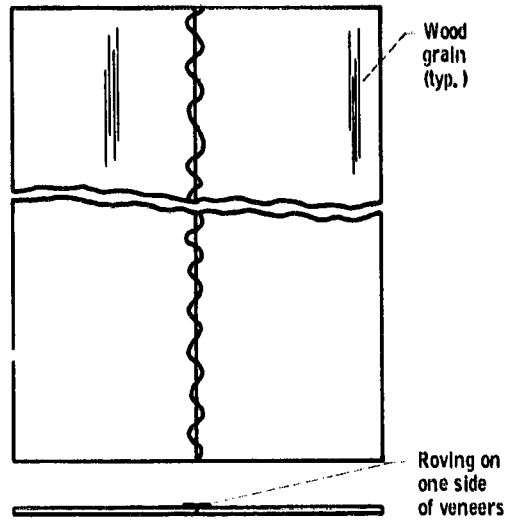

Figure 8. - Application of fiberglass roving on veneer edges by stitching machine.

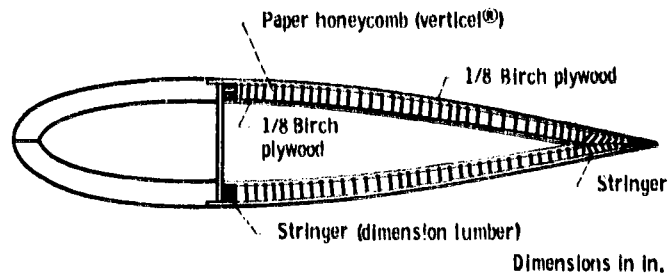

Figure 9. - Fully-supported cored afterbody.

ORIGINAL PHOTO OF POOR QUALITY

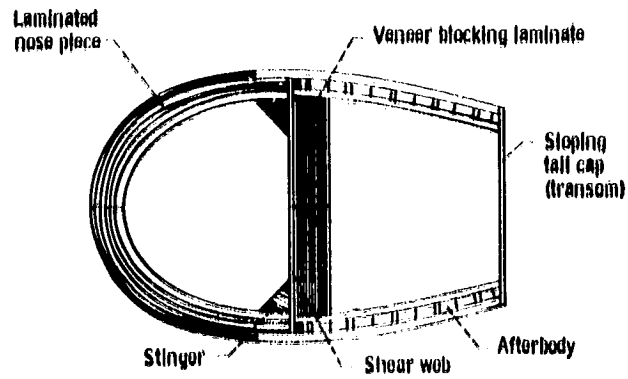
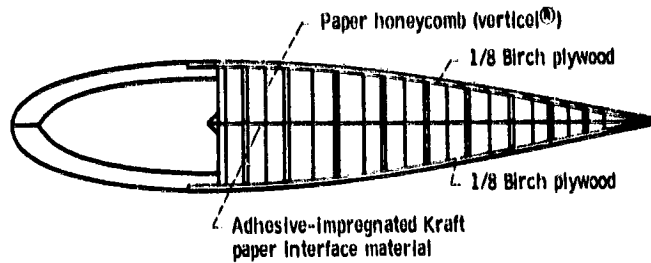

Figure 10. - Blade root build-up from root end to station 168.



Dimensions in in.

Figure 11. - Fully-cored section at outer tip of blade.

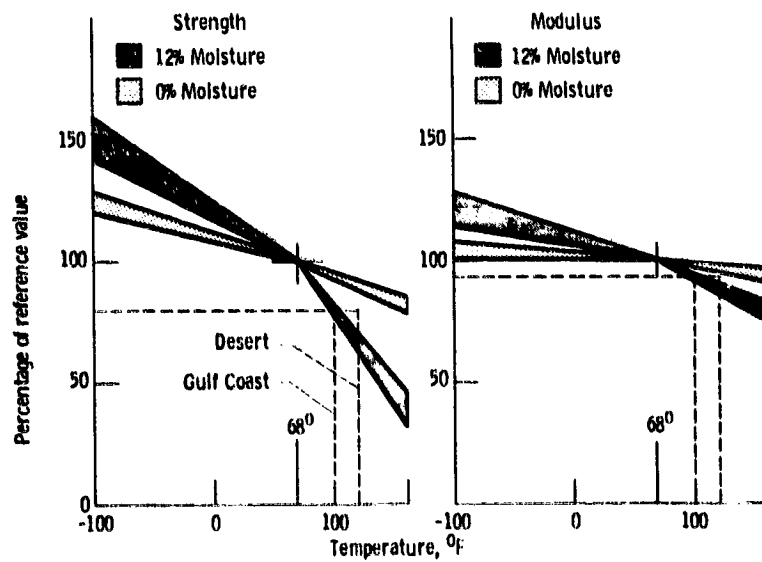

Figure 12. - Effect of temperature on mechanical properties of wood (ref. 7).

ORIGINAL PAGE IS
OF POOR QUALITY

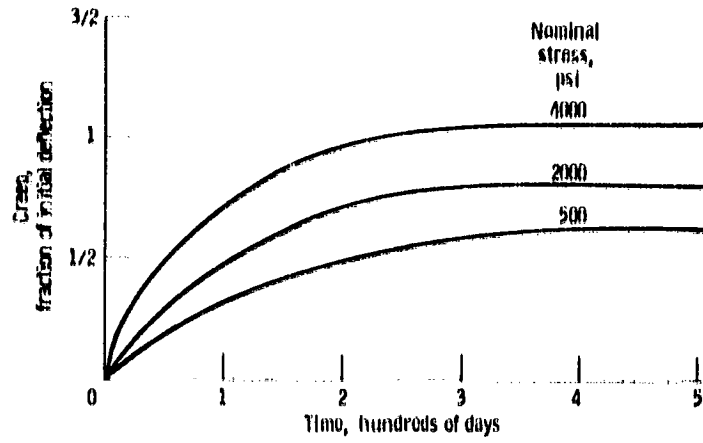

Figure 13. - Creep properties of wood (ref. 7).

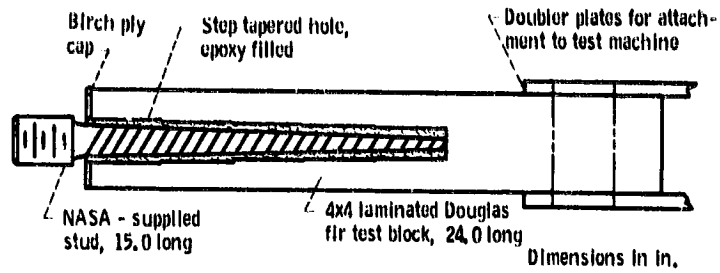

Figure 14. - Baseline specimen for test of stud bond strength.

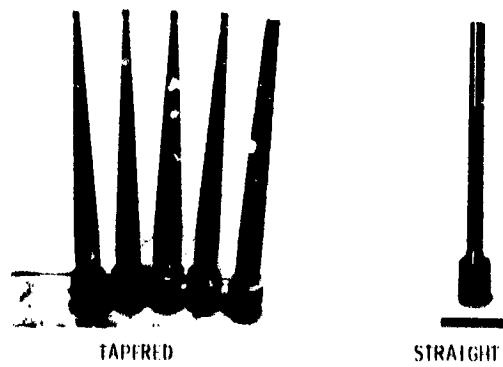

Figure 15. - Studs used in single-stud tests.

ORIGINAL PAGE IS
OF POOR QUALITY

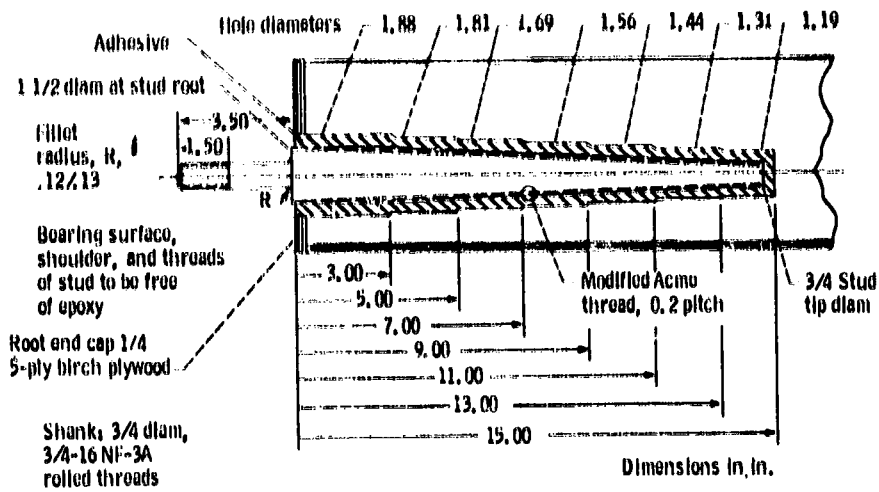

Figure 16. - Final stud design configuration

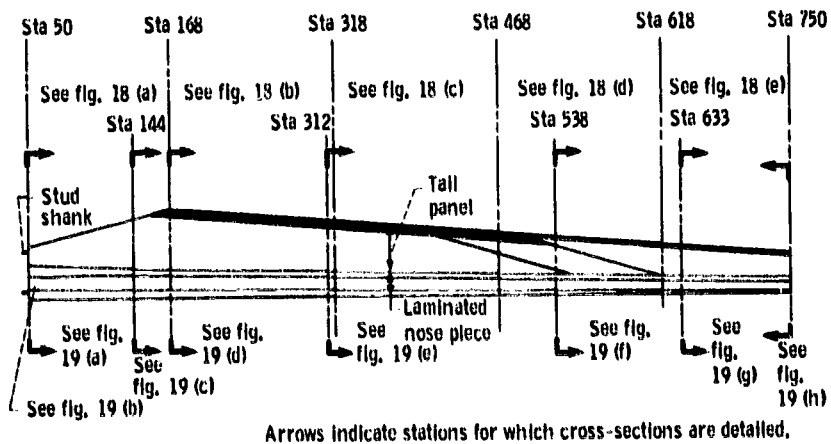
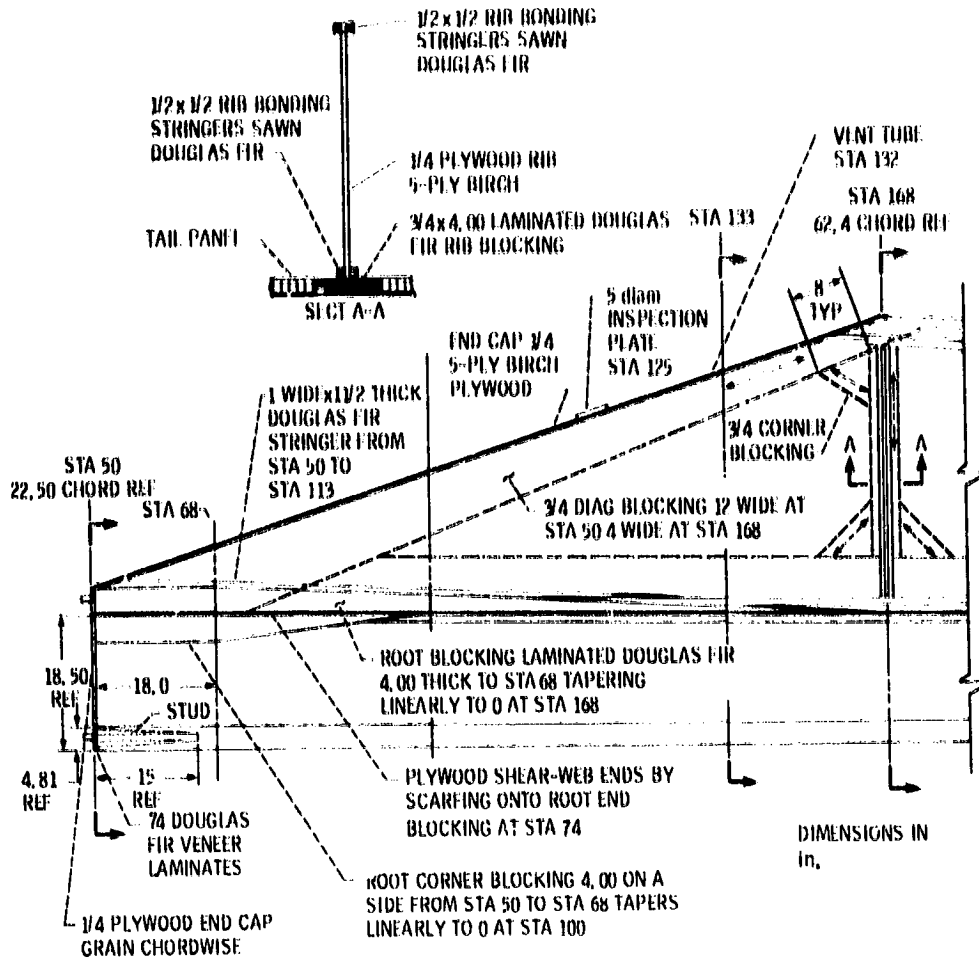
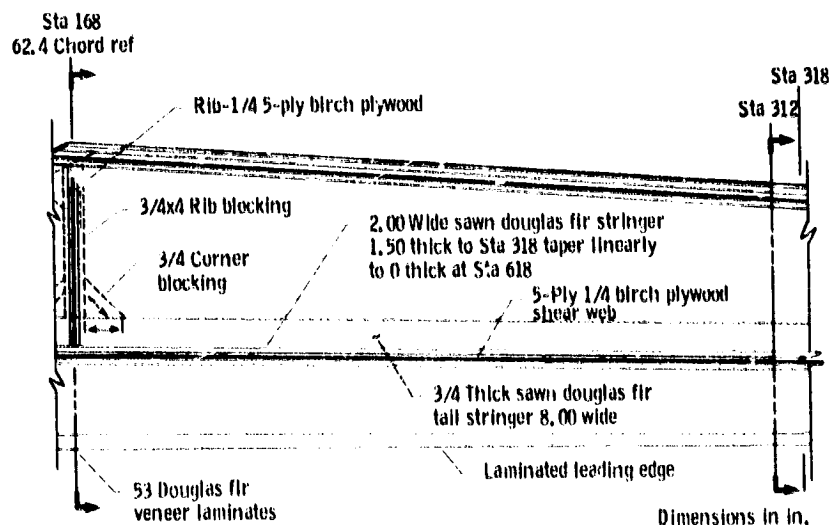

Figure 17. - Overall planform view of blade construction, looking into lower blade half (upper half removed).



(a) Stations 50 to 168.

Figure 18. - Details of blade construction, planform view of lower blade half.



(b) Stations 168 to 318.

Figure 18. - Continued.

GENERAL NOTES
 OF DRAWING

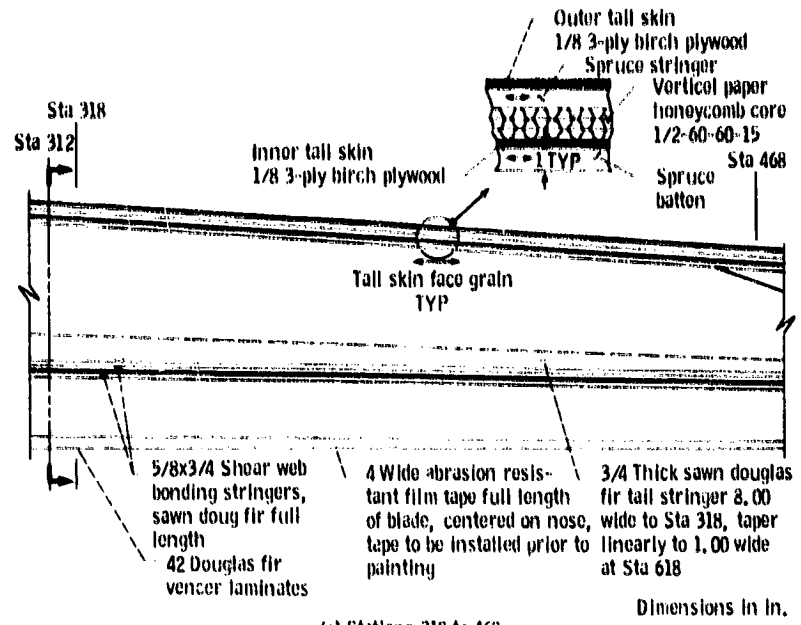

(c) Stations 318 to 468.

Figure 18. - Continued.

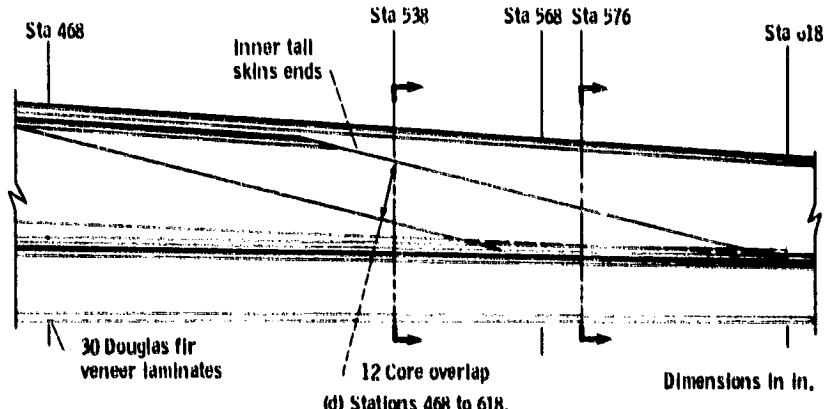

(d) Stations 468 to 618.

Figure 18. - Continued.

ORIGINAL PAGE IS
OF POOR QUALITY

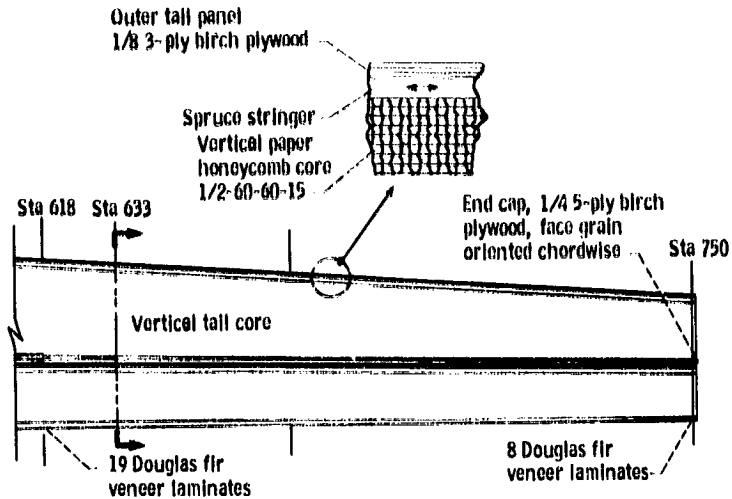

Dimensions in in.

(e) Stations 618 to 750.

Figure 18. - Concluded.

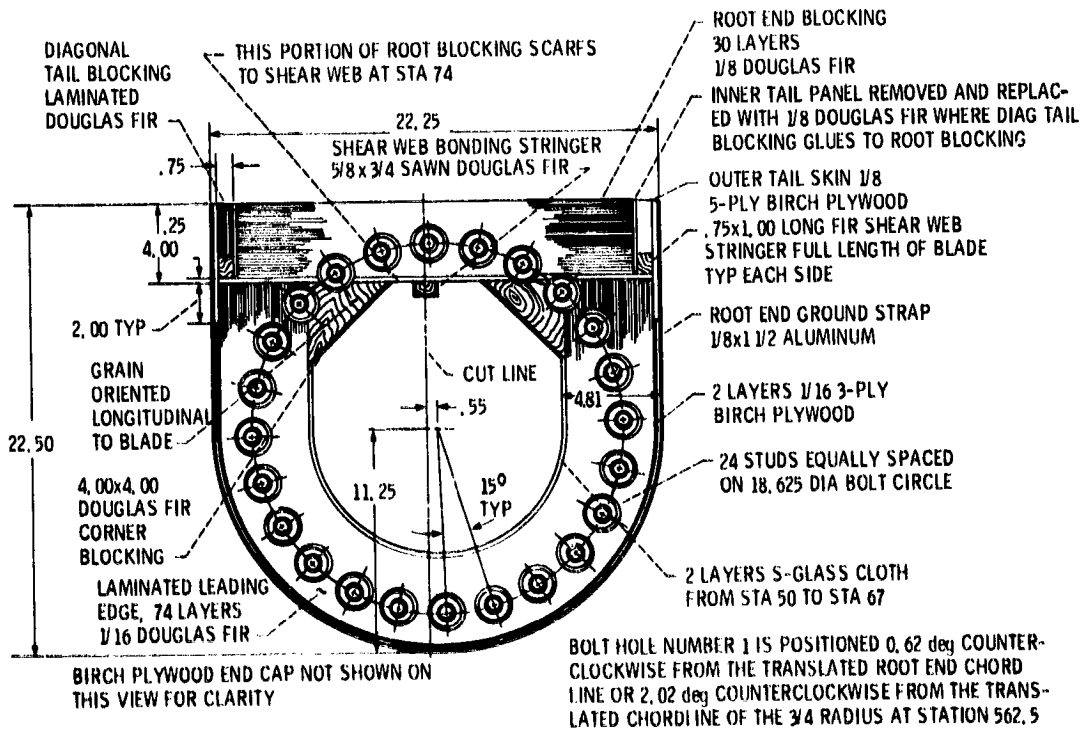

DIMENSIONS IN in.

(a) Blade root end, station 50.

Figure 19. - Detailed views of blade cross sections.

ORIGINAL DRAWING
DIE 1/2" X 1/2"

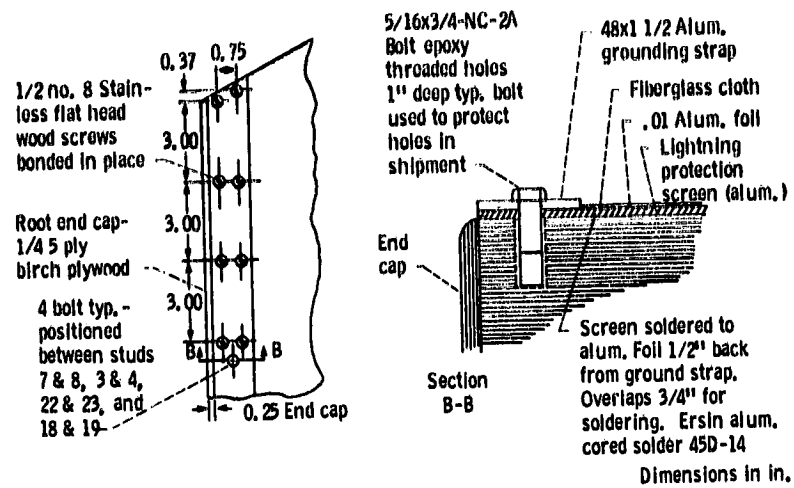

(b) Details of lightning protection grounding strap at blade root.

Figure 19. - Continued.

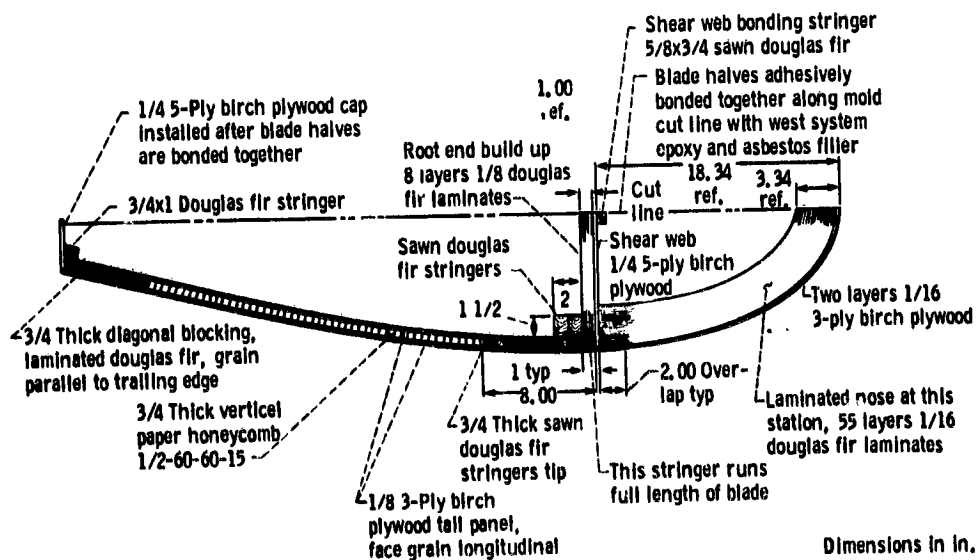

(c) Station 144.

Figure 19. - Continued.

ORIGINAL PAGE IS
OF POOR QUALITY

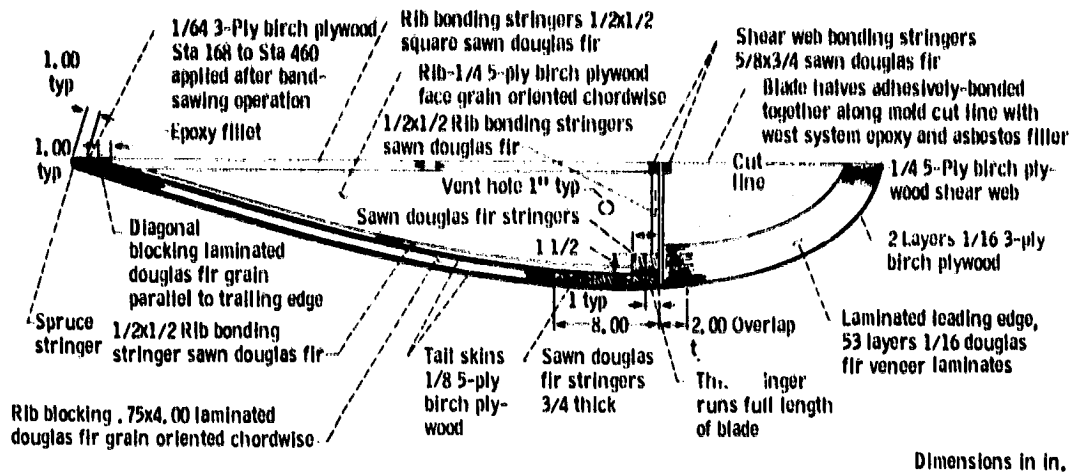

(d) Station 168.

Figure 19. - Continued.

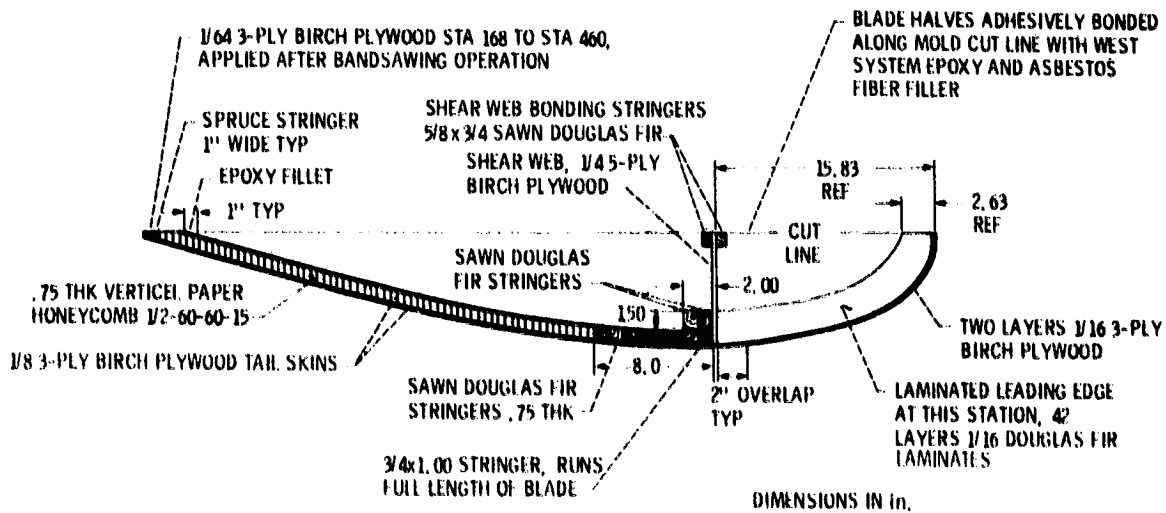

(e) Station 312.

Figure 19. - Continued.

ORIGINAL PAGE IS
OF POOR QUALITY

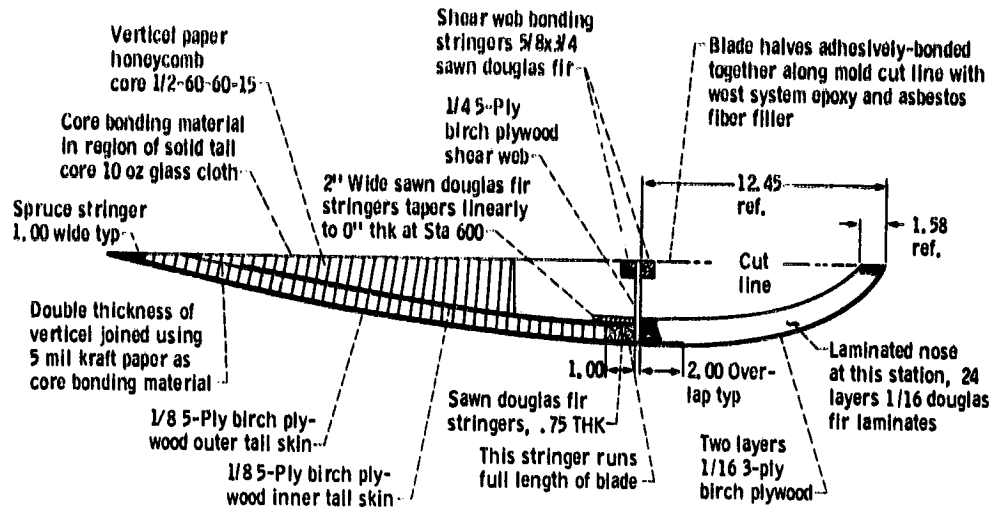

(f) Station 538.

Dimensions in In.

Figure 19. - Continued.

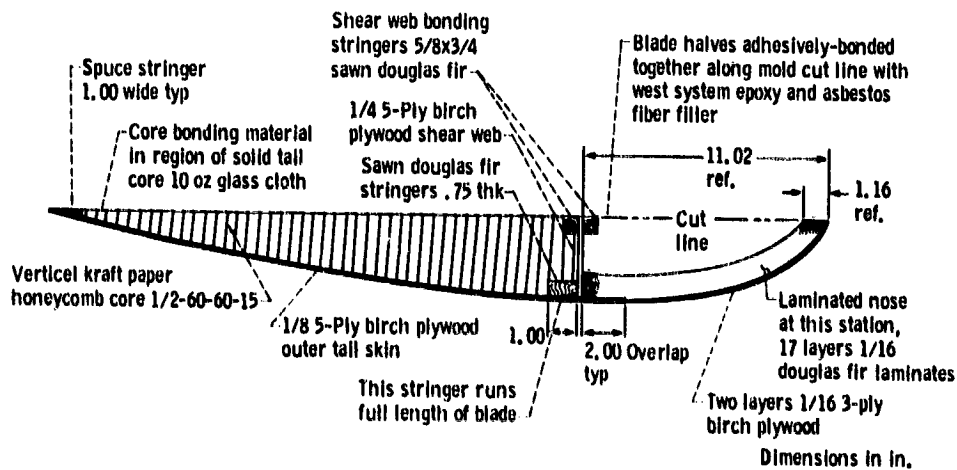

(g) Station 633.

Dimensions in In.

Figure 19. - Continued.

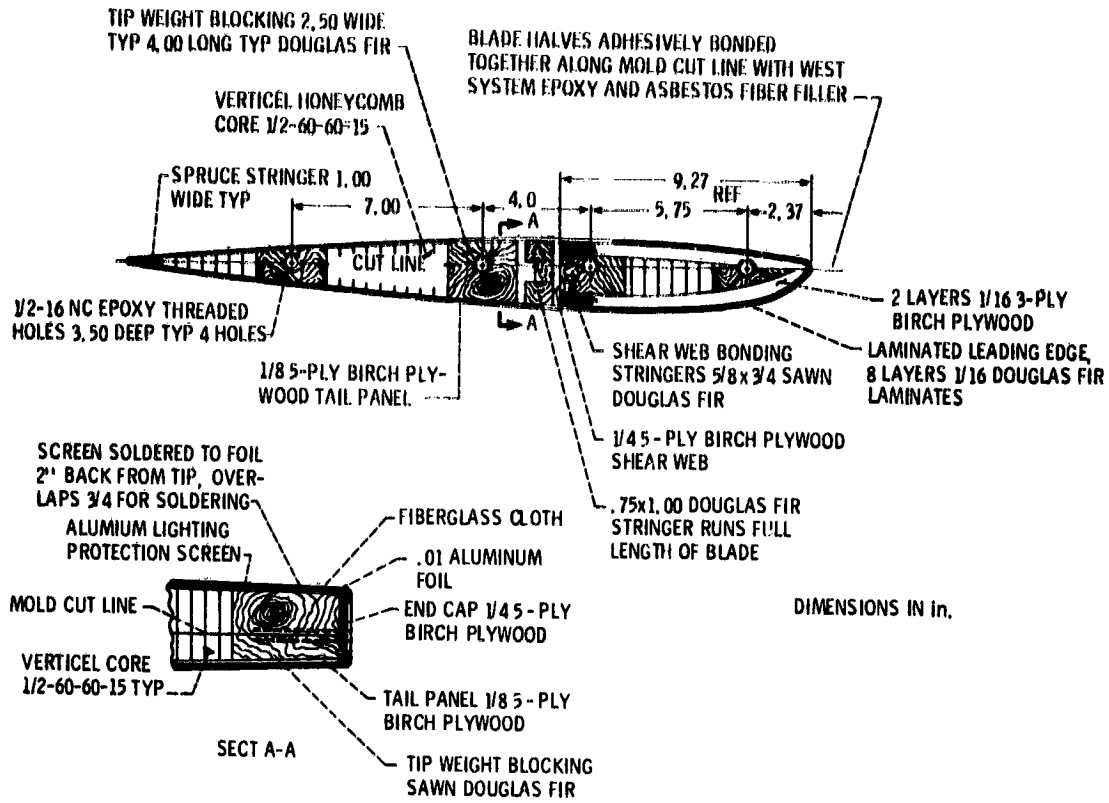

(h) Station 750.

Figure 19. - Concluded.

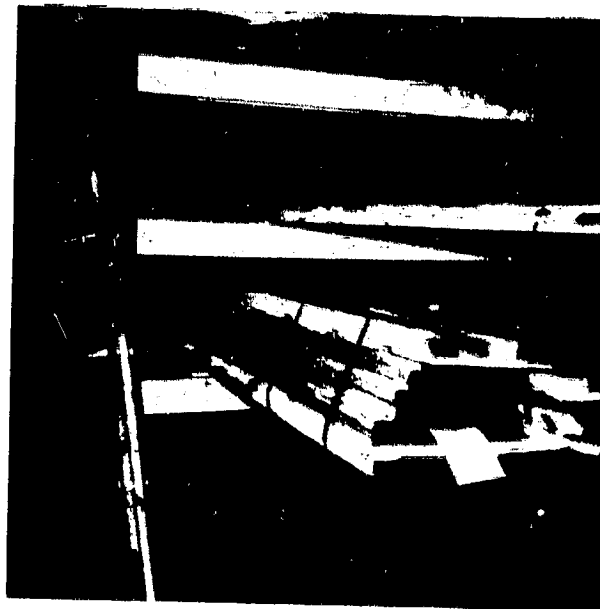

Figure 20. - Sliced veneers in as-received condition.

ORIGINAL PAGE IS
OF POOR QUALITY

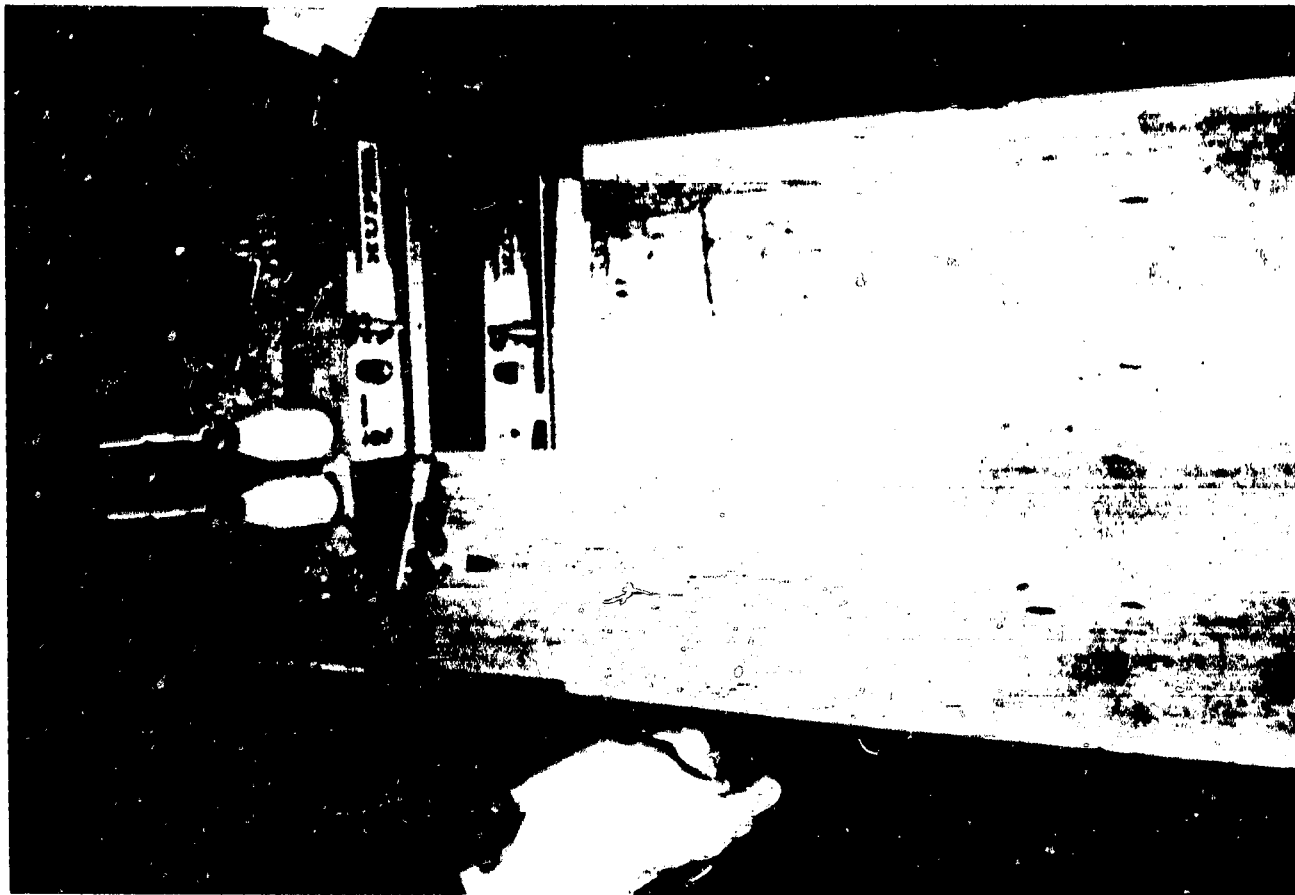

Figure 22. - Top view of veneer stitching operation.



Figure 21. - Veneer stitching machine.

ORIGINAL PAGE IS
OF POOR QUALITY

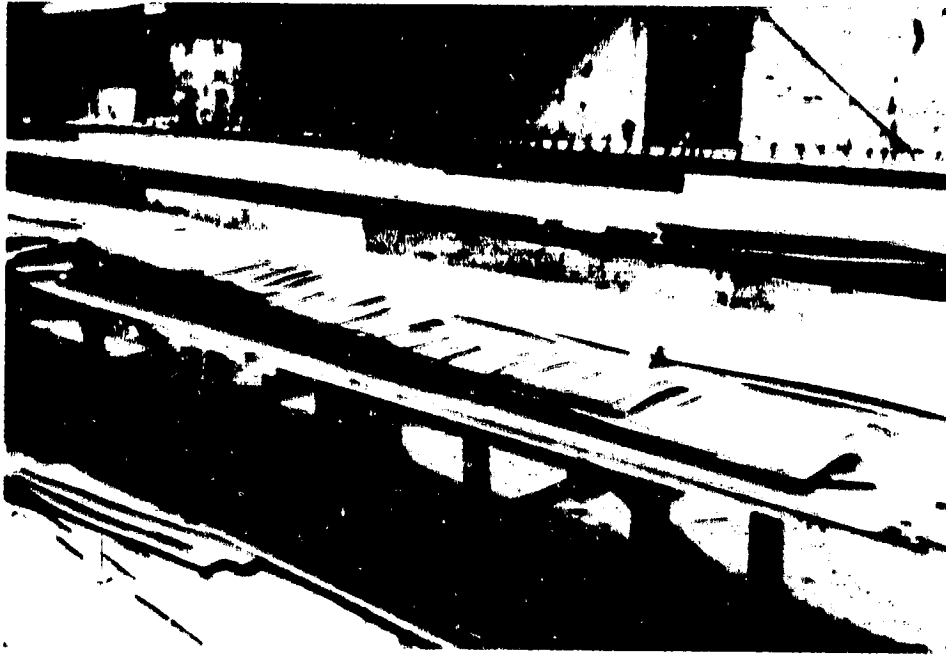

Figure 23. - Veneer layout table.

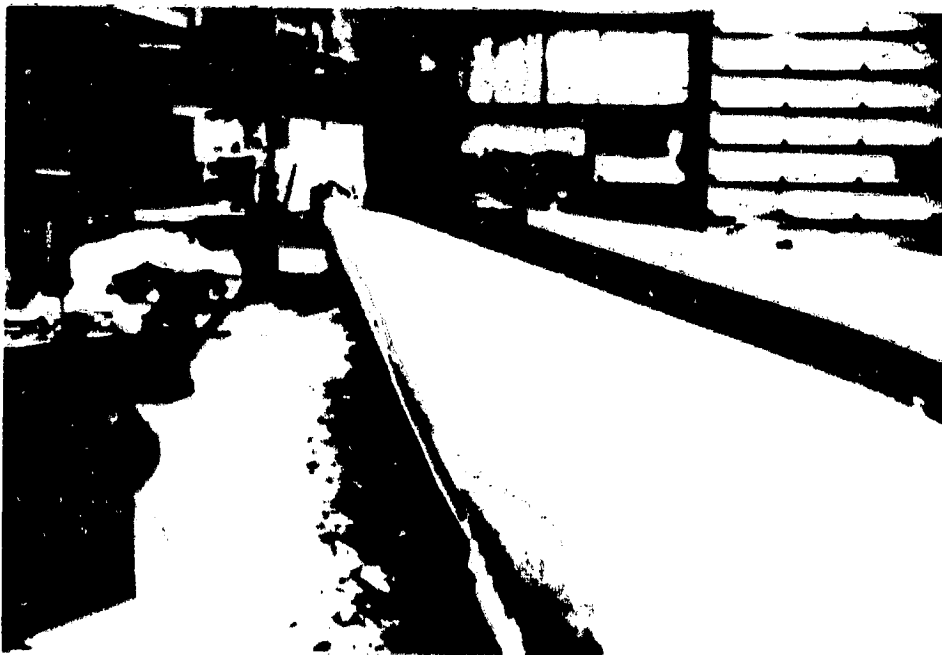

Figure 24. - Male molds.

ORIGINAL PAGE IS
OF POOR QUALITY

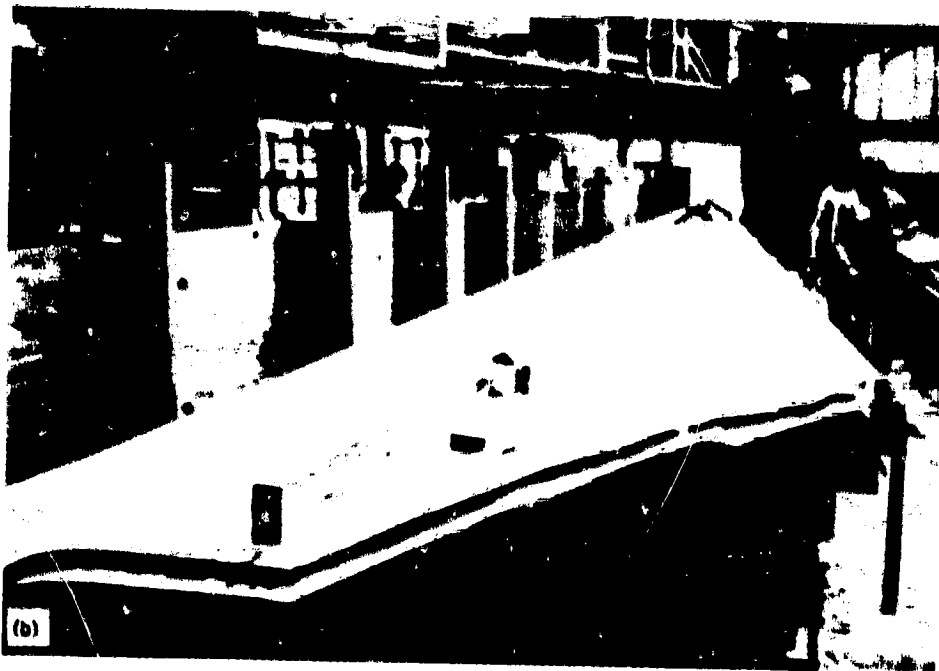
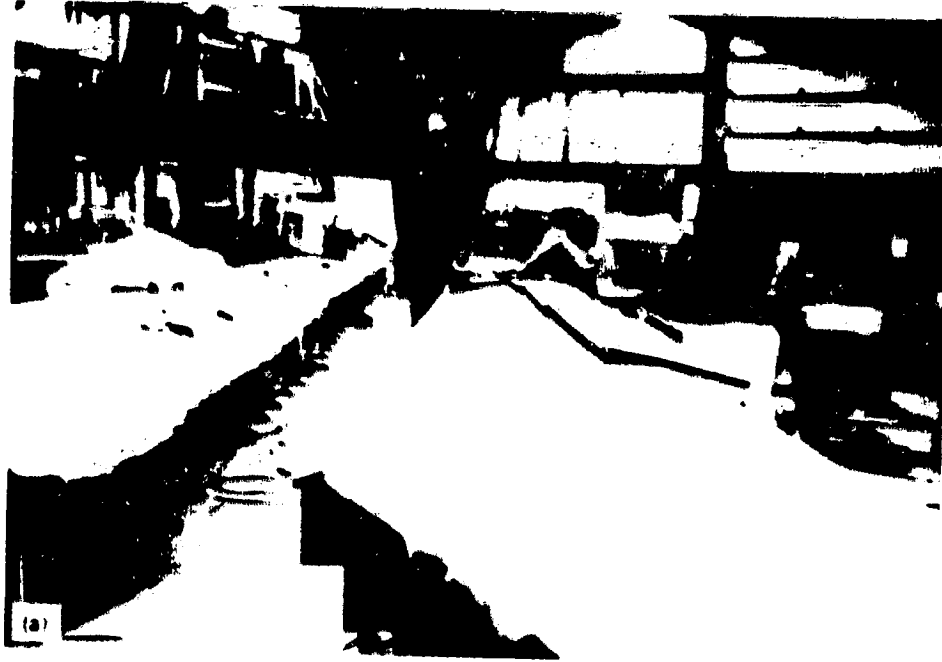

Figure 25. - Construction of female molds.

ORIGINAL PAGE IS
OF POOR QUALITY

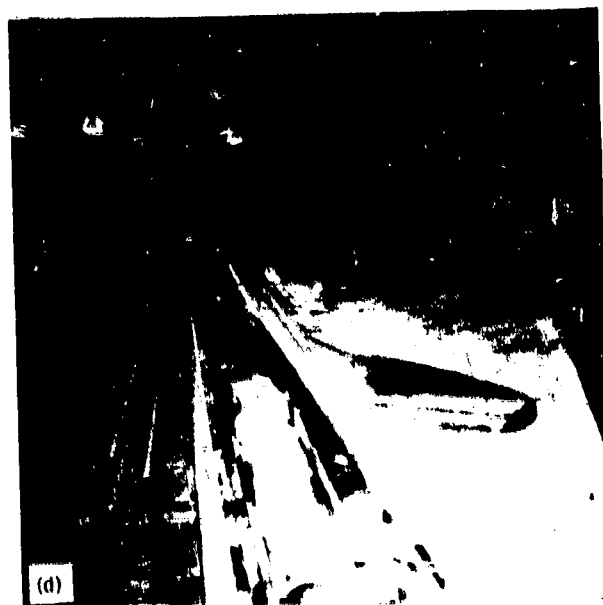
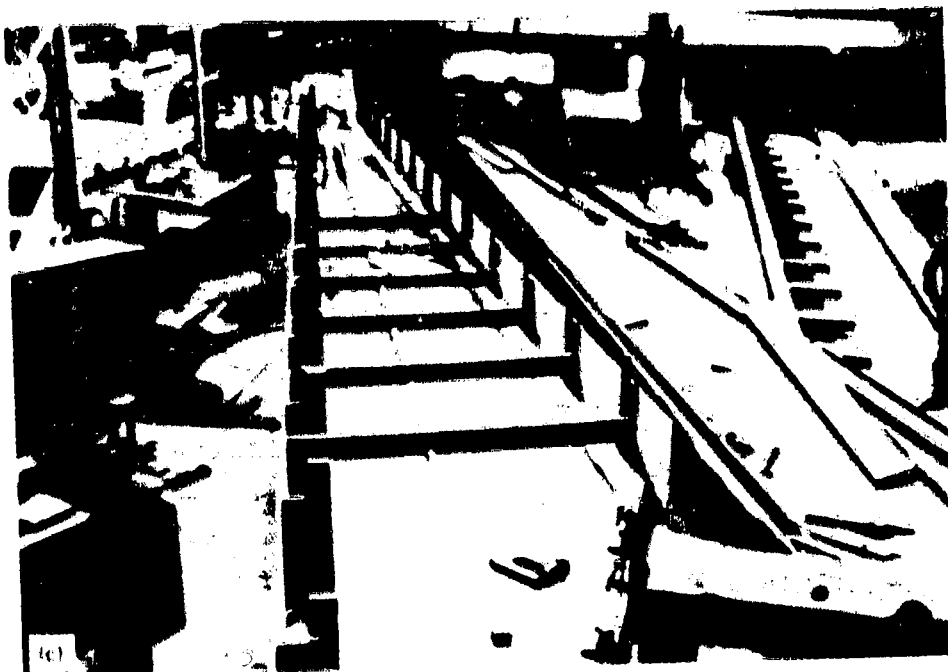

Figure 25. - Concluded.

ORIGINAL PAGE 13
OF POOR QUALITY

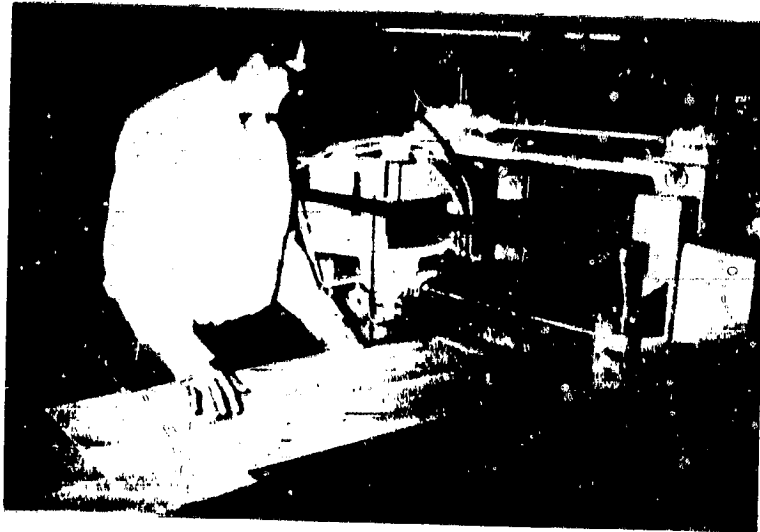

Figure 26. - Adhesive application machine.

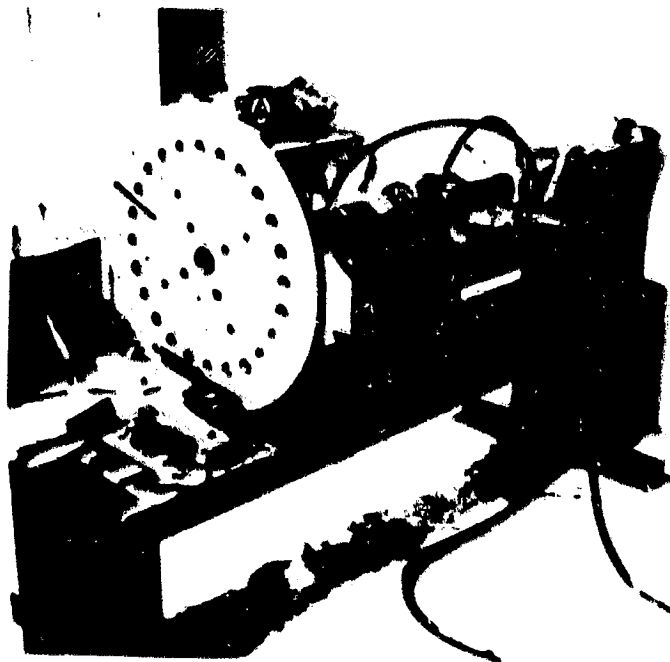

Figure 27. - Drilling and stud placement fixture.

ORIGINAL PHOTOGRAPH
OF POOR QUALITY

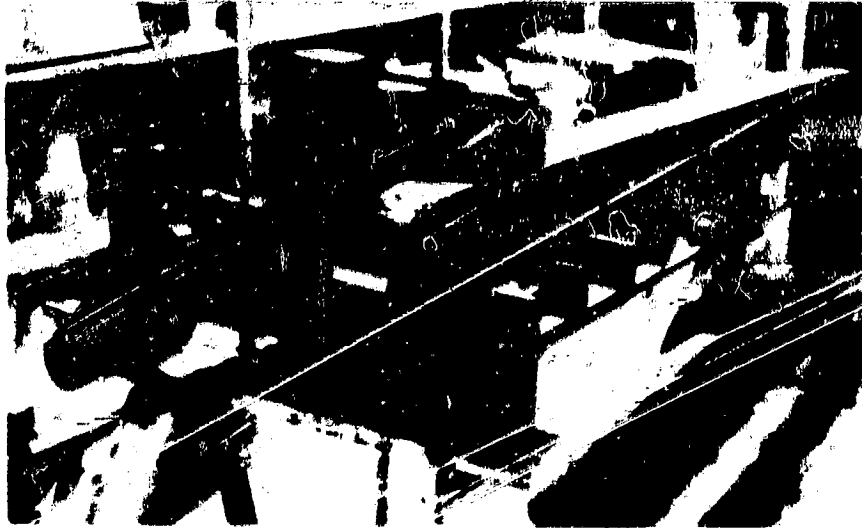

Figure 28. - Band saw.

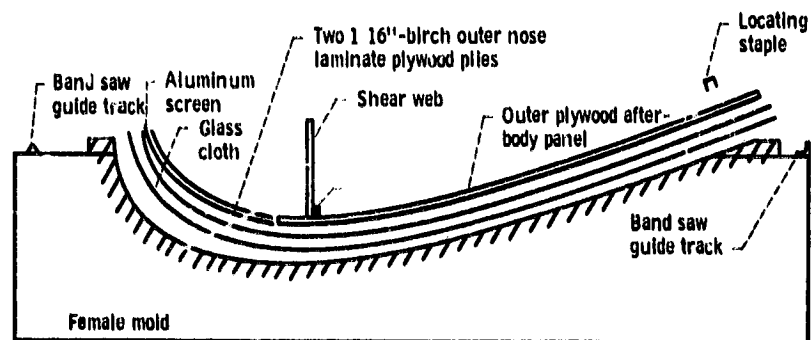

Figure 29. - Materials insertion in female mold.

**ORIGINAL PARTS
OF POOR QUALITY**

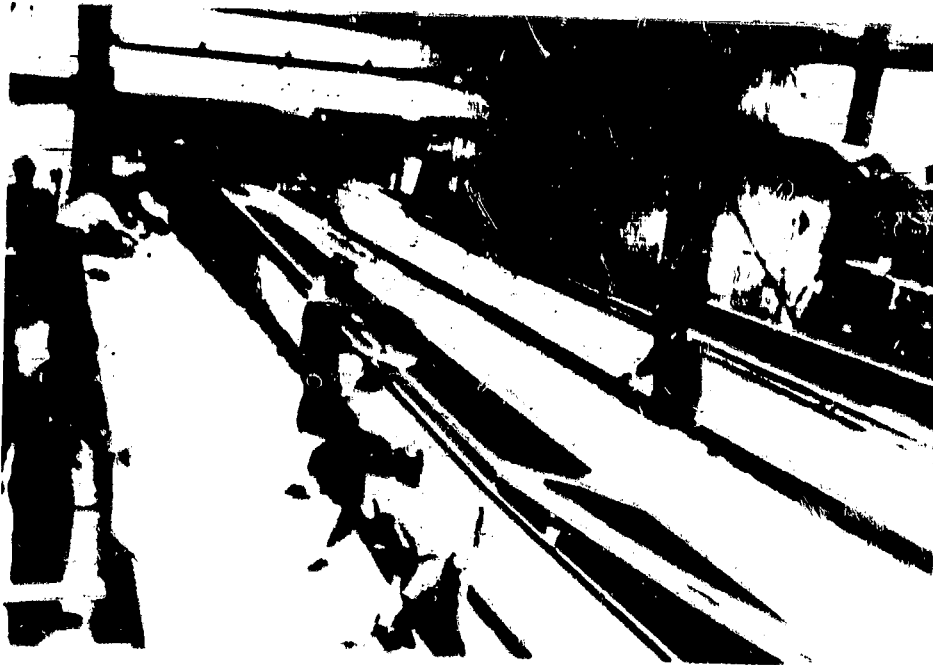

Figure 30. - Afterbody panel sub-assembly.

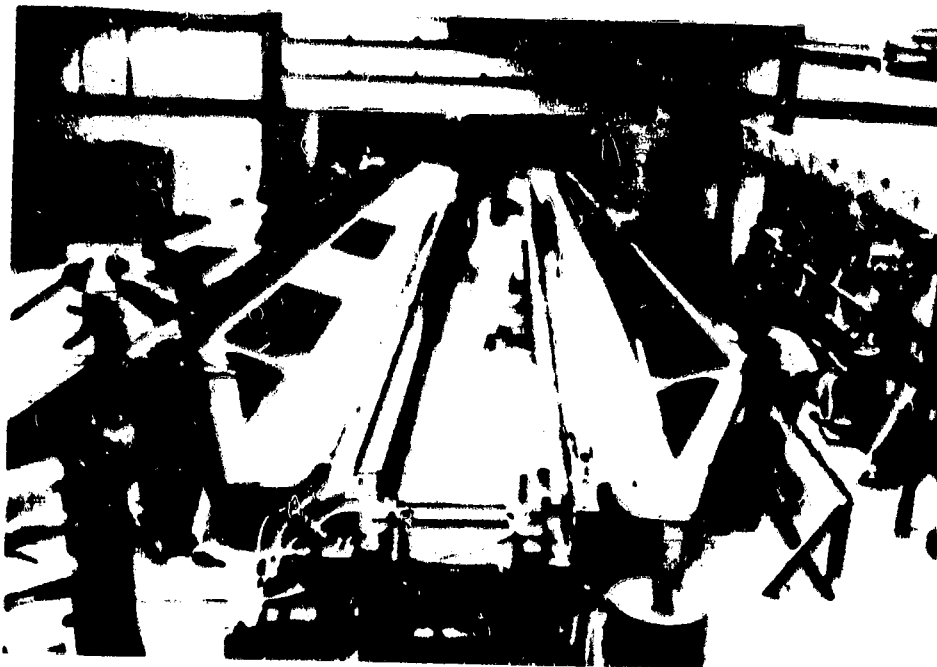

Figure 31. - Overall view of tail panel assembly.

ORIGINAL PAGE IS
OF POOR QUALITY

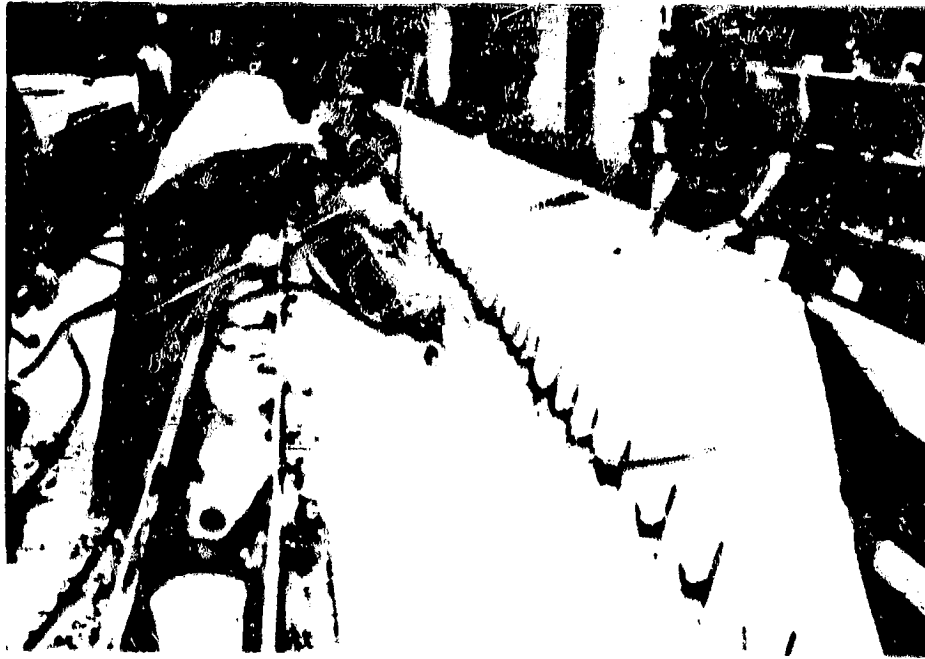

Figure 32. - Shear web assembly.



Figure 33. - Build-up of root-end shear web veneers.

ORIGINAL PAGE IS
OF POOR QUALITY



Figure 34. - View of nose piece laminates prior to vacuum bag compaction.

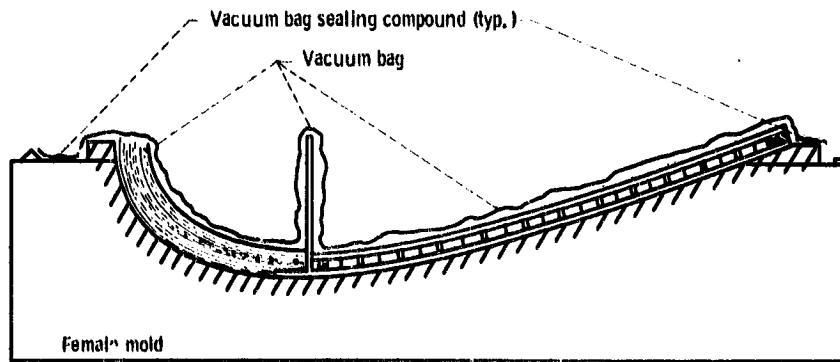

Figure 35. - Vacuum bag application.

**ORIGINAL PAGE IS
OF POOR QUALITY**



Figure 36. - View of nose piece laminate after completion of vacuum bag compaction and curing.

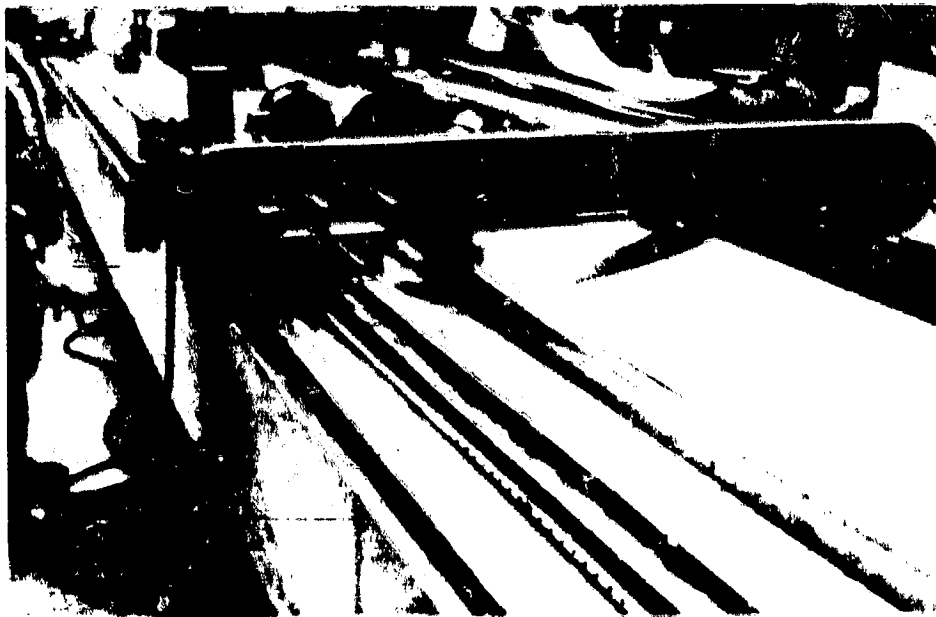

Figure 37. - Band saw trimming of blade half-shell.

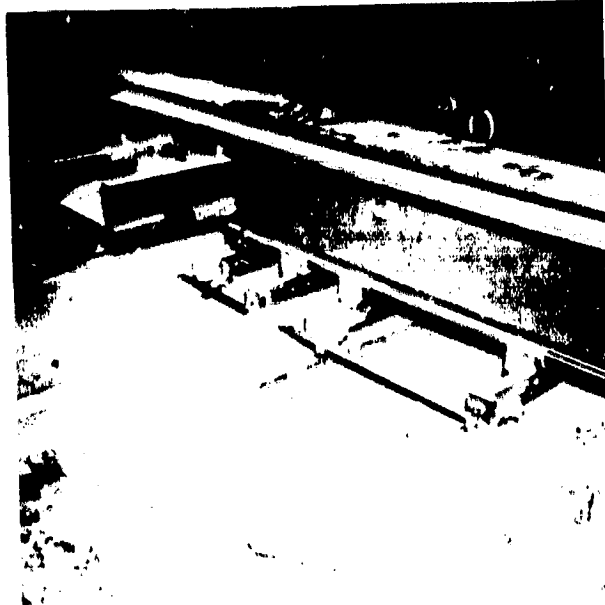

Figure 38. - Band saw cutting the tip area honeycomb comb material.

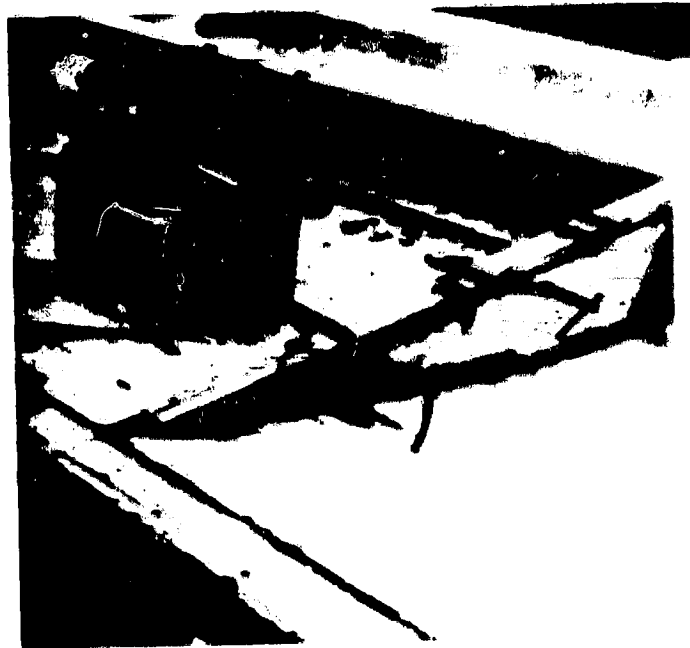

Figure 39. - Installation of station 168 rib.

ORIGINAL PAGE IS
OF POOR QUALITY

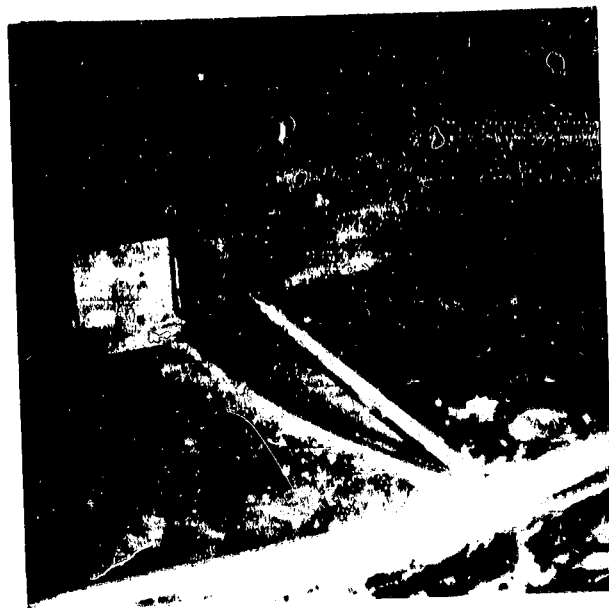

Figure 40. - Station 168 rib installation completed.

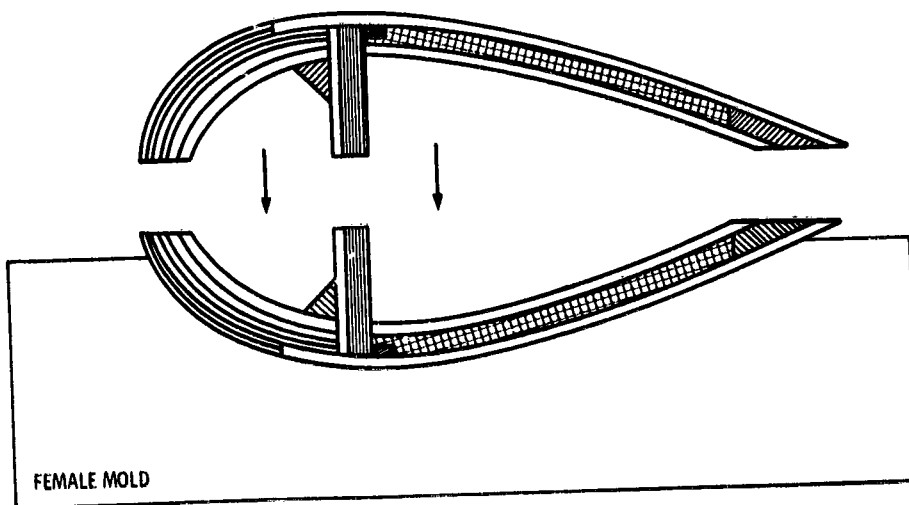

Figure 41. - Bonding of half-shells into complete blade structure.

ORIGINAL PAGE IS
OF POOR QUALITY

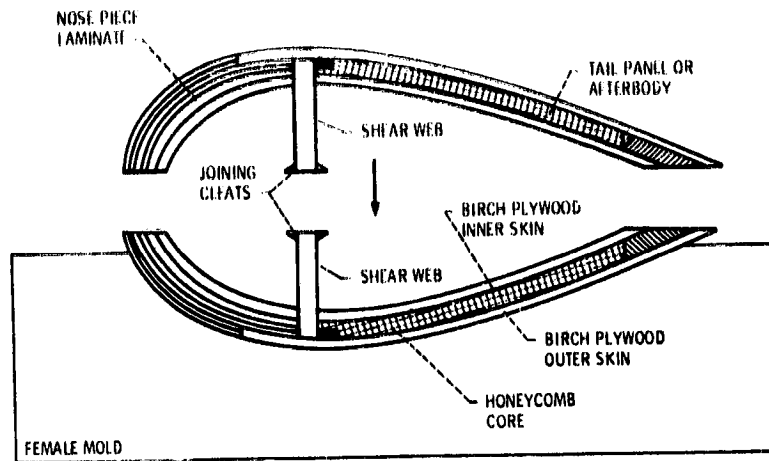

Figure 42. - Bonding of two blade half-shells about mid-span.

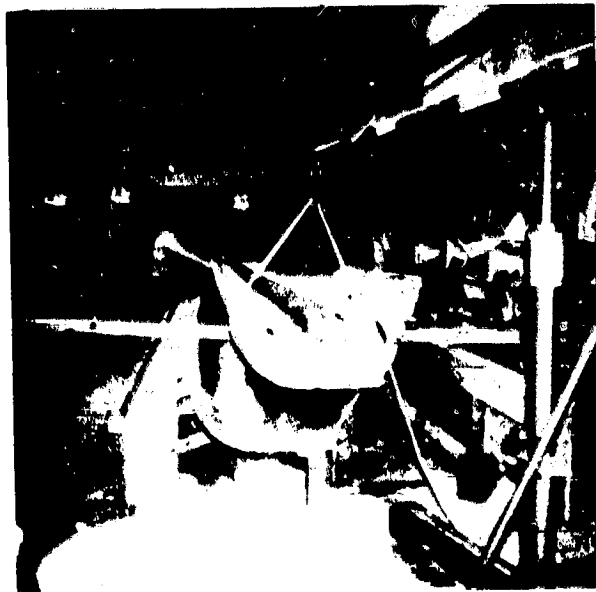

Figure 43. - Lifting completed blade half-shell from female mold.

ORIGINAL PAGE IS
OF POOR QUALITY

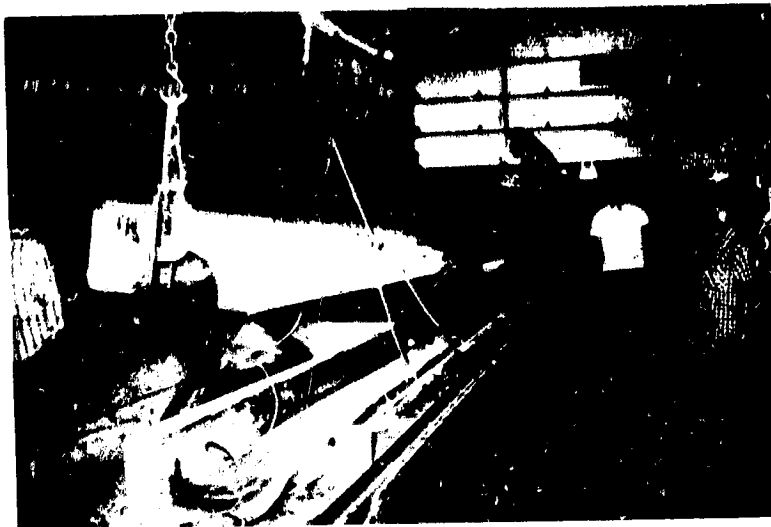

Figure 44. - Preparation for blade half-shell bonding.



Figure 45. - Rough trimmed root end.

ORIGINAL PAGE 12
OF POOR QUALITY



Figure 46. - Rough trimmed blade tip.



Figure 47. - View of routed root end.

ORIGINAL PAGE IS
OF POOR QUALITY

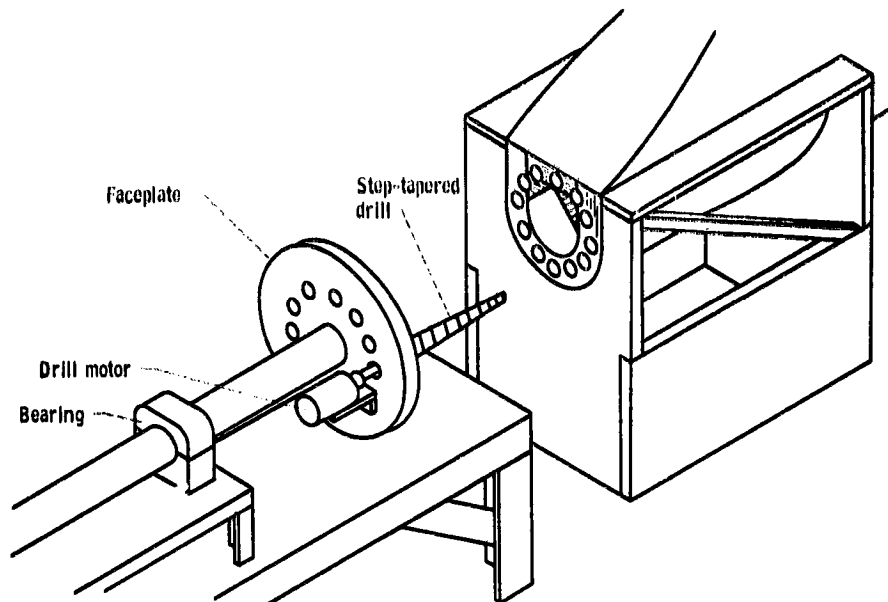

Figure 48. - Schematic of stud drilling fixture.



Figure 49. - Drilling fixture with drill motor.

ORIGINAL PAGE IS
OF POOR QUALITY



Figure 50. - Hole drilling.



Figure 51. - Drilled holes.

**ORIGINAL PAGE IS
OF POOR QUALITY**

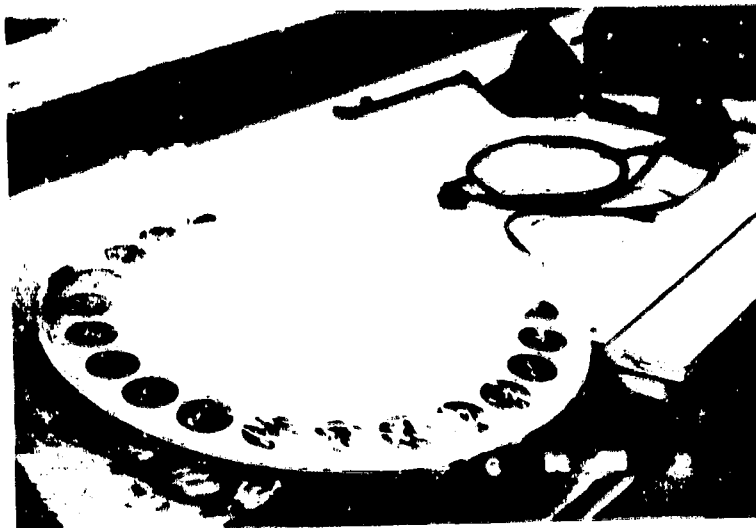

Figure 52. - Spacing fixture.

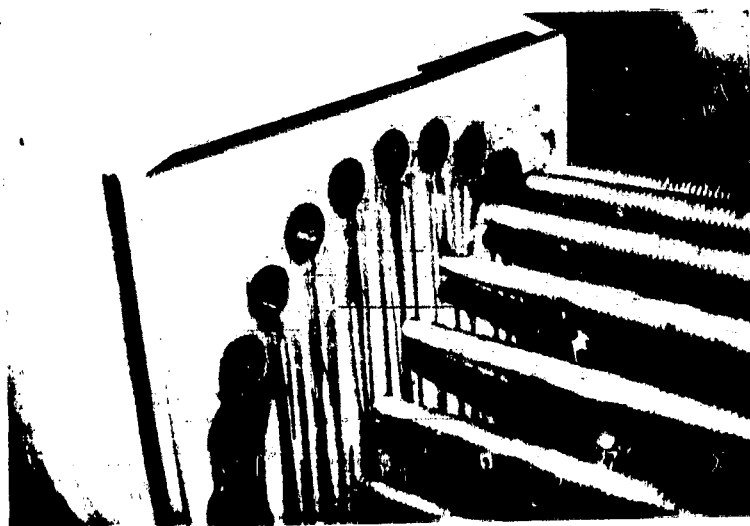

Figure 53. - Application of priming adhesive to holes.

ORIGINAL PAGE IS
OF POOR QUALITY



Figure 54. - Application of thixo adhesive to holes.



Figure 55. - Application of thickened adhesive to studs.

ORIGINAL PAGE IS
OF POOR QUALITY

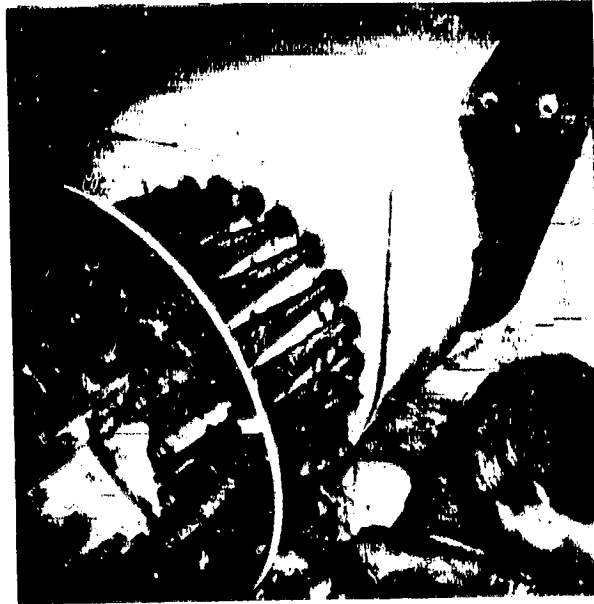

Figure 56. - Insertion of studs into holes.

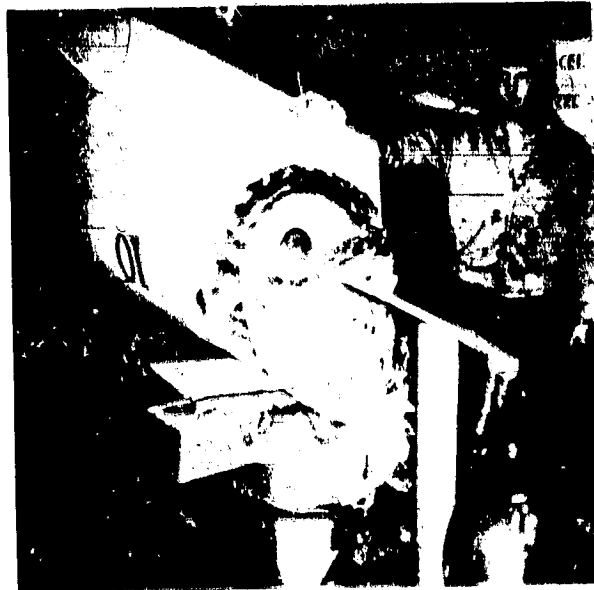

Figure 57. - Blade ballasting process.

ORIGINAL PAGE IS
OF POOR QUALITY

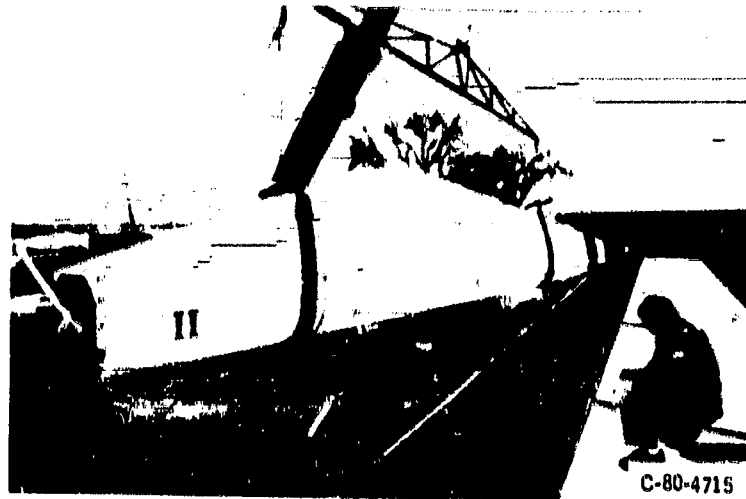
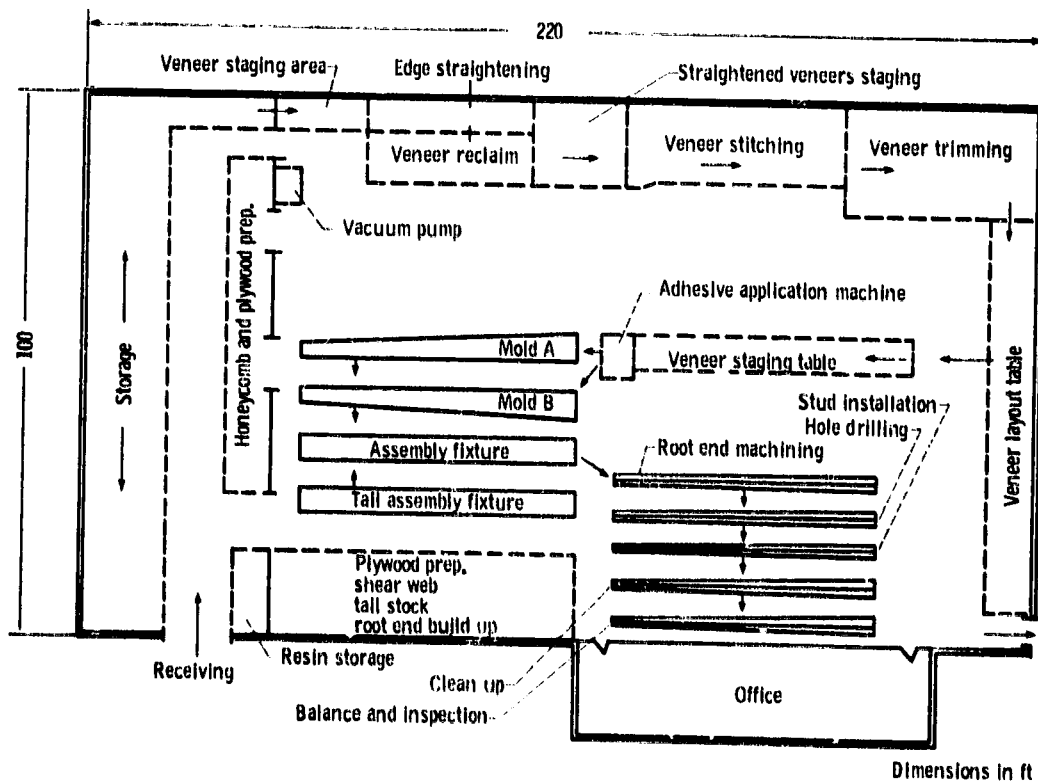

Figure 58. - Preparation for shipment.



(a) Module for 120 blades/yr (1 shift) to 240 blades/yr (2 shifts).

Figure 59. - Proposed manufacturing plant for MOD-0A wood composite blades.

ORIGINAL PAGE IS
OF POOR QUALITY

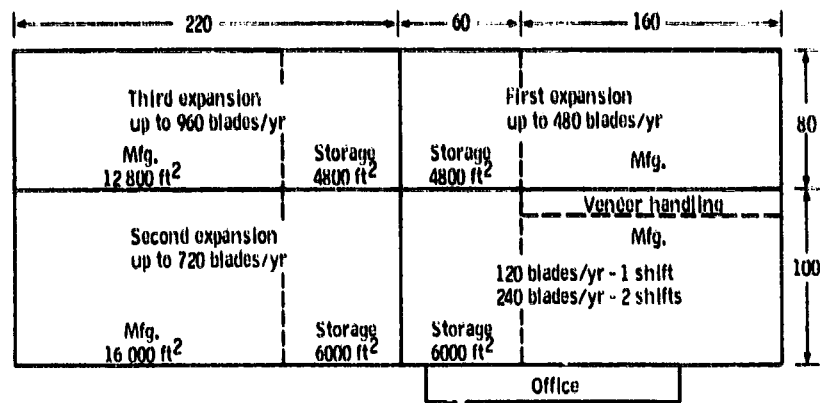

(b) Expansion plan for 960 blades per year (two shifts).
Dimensions in ft

Figure 59. - Concluded.