

ADVANCED COPY

Airborne Multispectral Linear Array Instruments

at

Goddard Space Flight Center

James R. Irons  
James C. Smith  
William L. Barnes

The fabrication of airborne instruments is contributing to the development of multispectral linear array (MLA) technology at NASA's Goddard Space Flight Center (GSFC). GSFC's first MLA instrument, the Linear Array Pushbroom Radiometer (LAPR-I), was built in 1979 to demonstrate capabilities for acquiring digital image data using linear arrays (Fig. 1). LAPR-I employed three arrays of 512 silicon photodiodes each to simultaneously acquire three channels of data for spectral bands within the visible and near-infrared portions of the spectrum. LAPR-I was operated from aircraft during 1979 to 1981 and useful imagery and thematic maps were derived from the digital image data (Wharton et al., 1981).

A second instrument, LAPR-II, is being built to enhance data acquisition capabilities for scientific investigations (Fig. 2). LAPR-II will use four arrays each consisting of 512 silicon detectors. A filter wheel containing six spectral filters will be used in conjunction with each array to allow filter changes in flight. This capability will facilitate studies into the utility of various bands within the visible and near infrared portions of the spectrum (0.4-1.0  $\mu\text{m}$ ). LAPR-II's aircraft mounting will allow off-nadir pointing (plus-or-minus 50° fore-and-aft and side-to-side) which will enable investigations of the radiometric and geometric effects of off-nadir viewing. The spatial and spectral characteristics of LAPR-II will be quantitatively characterized and the radiometric response of each detector will be calibrated before the instrument is flown in 1983 (Irons et al., 1982). Fabrication will be completed and test flights will be conducted in the late summer of 1982. LAPR-II will provide investigators with a well-described, flexible source of digital image data for scientific research.

A third linear array instrument has recently been completed for sensing energy within an additional portion of the spectrum. The Short Wave Infrared Radiometer (SWIR) will use a single array of 64 lead-sulfide detectors to acquire data for spectral bands within the 1.0  $\mu\text{m}$  to 2.6  $\mu\text{m}$  region (Fig. 3). An 80-hertz chopper blade is used to minimize electrical noise and drift. A filter wheel provides a selection of three spectral filters which can be switched in flight. SWIR has been operated in the laboratory and test flights are planned for the late summer 1982.

In the future, consideration will be given to the development of an airborne area array instrument (Fig. 4). This instrument would employ a two-dimensional array of detectors where each row of detectors would sense a narrow spectral band. An investigator could select data from any combination of detector rows or could integrate the signal from several adjacent rows to create a spectral band configuration which meets the requirements of a specific mission.

The creation of the airborne instruments is developing expertise in the design, fabrication, calibration, and operation of multispectral linear array systems. Furthermore, the instruments will provide investigators with a versatile source of digital image data. The instruments will familiarize both scientists and engineers with the attributes of MLA technology.

REFERENCES CITED

Irons, J. R., J. C. Smith, L. R. Blaine, and M. W. Finkel. 1982. A Plan for the Characterization, Calibration, and Evaluation of LAPR-II. NASA Technical Memorandum 83915. Goddard Space Flight Center, Greenbelt, MD.

Wharton, S. W., J. R. Irons, F. Huegel. 1981. LAPR: An Experimental Pushbroom Scanner. Photogrammetric Engineering and Remote Sensing, Vol. 47, No. 5. pp. 631-639.

# LAPR-1

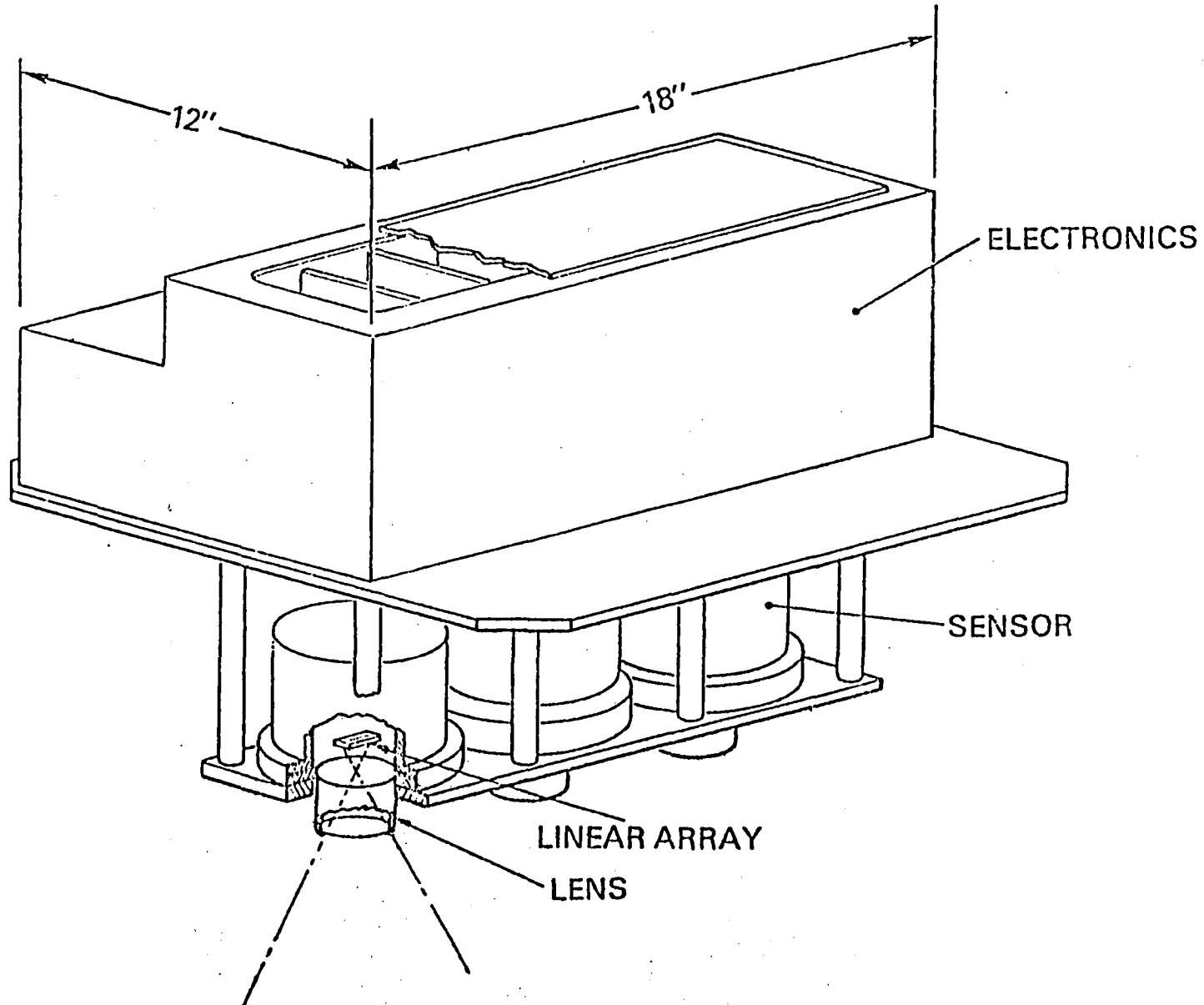

191

Figure 1. The First Linear Array Pushbroom Radiometer

# LAPR-II

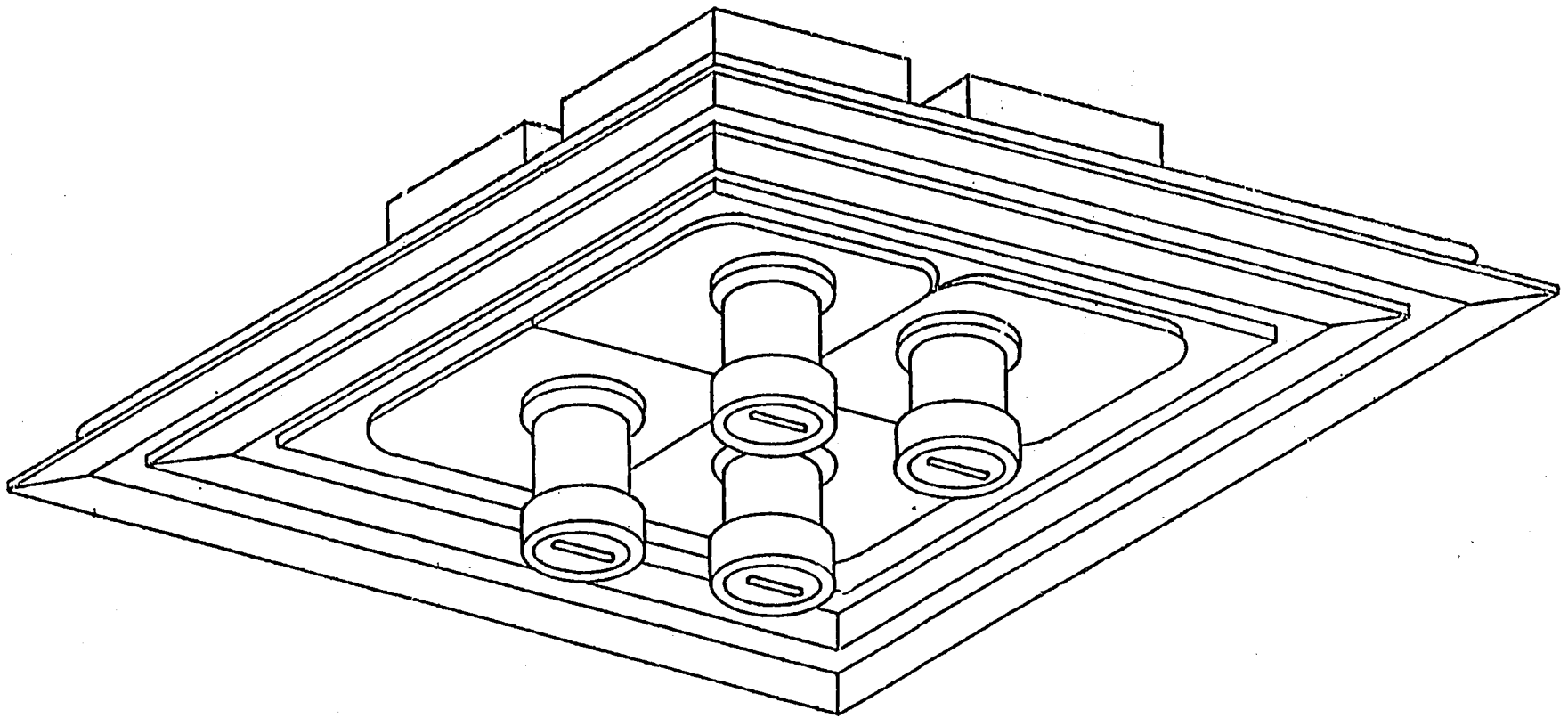

Figure 2. The Second Linear Array Pusibroom Radiometer

# LAPR-SWIR

FILTER WHEEL  
MOTOR

FILTER WHEEL

DETECTOR

LENS

CHOPPER  
BLADE

CHOPPER  
MOTOR

ELECTRONICS

Figure 3. The Short Wave Infrared Radiometer

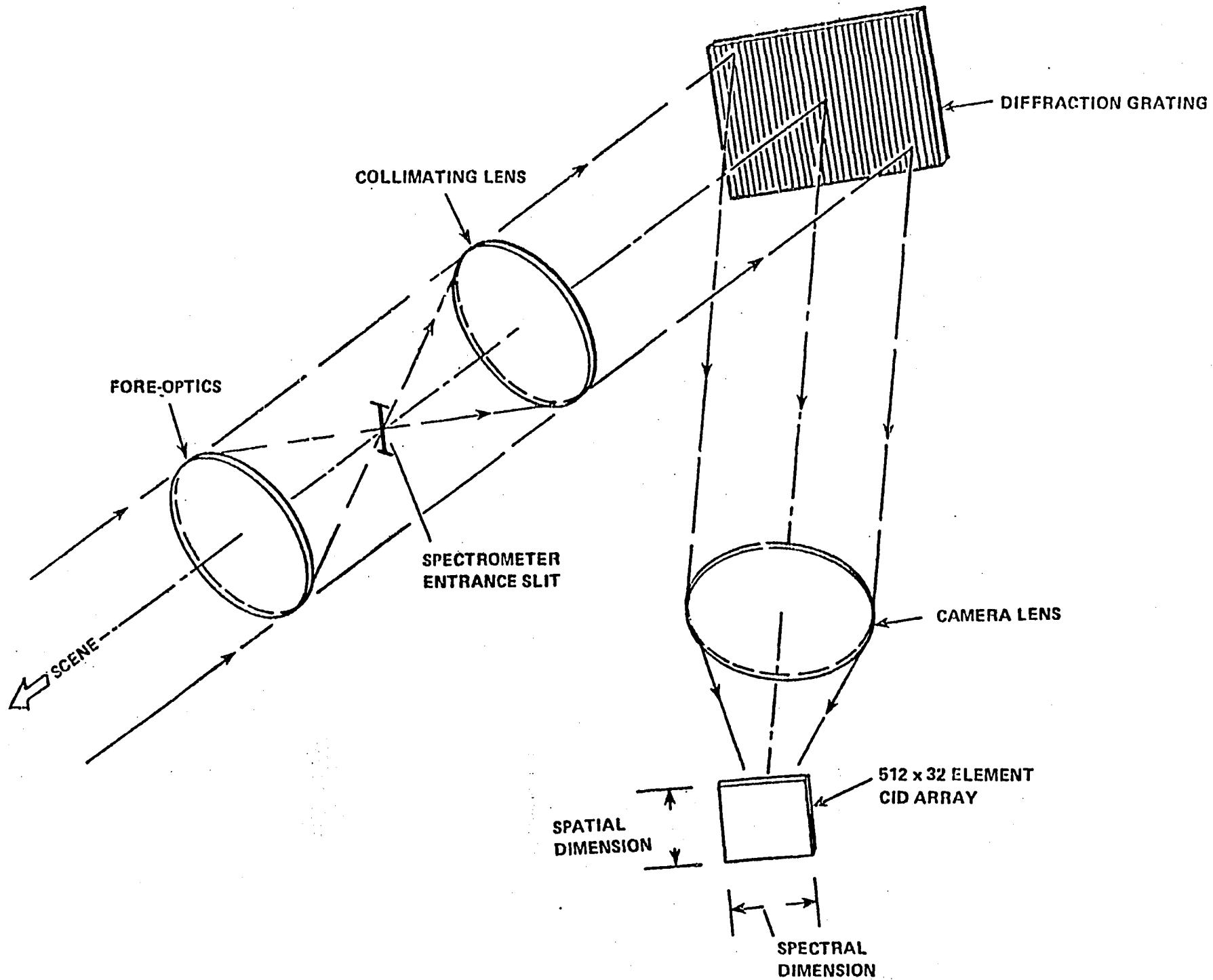

Figure 4. Configuration of an Airborne Area Array Instrument



NASA - NSTL EARTH RESOURCES LABORATORY  
SENSOR DEVELOPMENT  
OVERVIEW

- OPERATIONAL SENSORS
  - \* ● THEMATIC MAPPER SIMULATOR (TMS) (0.46 $\mu$  - 12.3 $\mu$ )
  - S-191 FIELD SPECTROMETER (0.45 $\mu$  - 2.5 $\mu$ )
  - THEMATIC MAPPER RADIOMETER (0.45 $\mu$  - 0.90 $\mu$ )
  
- DEVELOPMENTAL SENSORS
  - \* ● THERMAL INFRARED MULTISPECTRAL SCANNER (TIMS) (8.2 $\mu$  - 12.2 $\mu$ )
  
- DESIGN STUDIES
  - \* ● VARIABLE RESOLUTION MULTI-LINEAR ARRAY PUSHBROOM SCANNER (0.45 $\mu$  - 1.10 $\mu$ )
  - ACTIVE (TARGET - ILLUMINATING) MULTISPECTRAL SCANNER (0.45 $\mu$  - 1.10 $\mu$ )
  - SCANNING TERRAIN PROFILER
  - MICROPROCESSOR CONTROLLED SPECTROMETER (0.40 $\mu$  - 14.0 $\mu$ )

## THEMATIC MAPPER SIMULATOR (TMS)

- SINGLE CHANNEL THERMAL SCANNER (ANALOG) PURCHASED FROM TEXAS INSTRUMENTS IN 1971.
- CONVERTED TO FIVE BAND (LANDSAT MSS + THERMAL) SCANNER (DIGITAL) IN 1974.
- CONVERTED TO SEVEN BAND (LANDSAT D THEMATIC MAPPER) SIMULATOR IN 1980.
  - CONVERSION TO TMS ACCOMPLISHED IN-HOUSE FOR \$42K
- FIRST FLIGHT ON MAY 30, 1980, WITH FLIGHT EVALUATION JUNE-SEPTEMBER, 1980.
  - 12 MISSIONS CONDUCTED OVER 6 TEST SITES, INCLUDING DOS TEST SITES.
- SYSTEM OPERATIONAL OCTOBER, 1980.
- SPECTRAL/SPATIAL CAPABILITIES.

| BAND | LANDSAT-D |                     | NSTL    |                     | TMS     |                     | LANDSAT-D           |                     | TM                  |             |
|------|-----------|---------------------|---------|---------------------|---------|---------------------|---------------------|---------------------|---------------------|-------------|
|      | SPATIAL   | TM SPECTRAL         | SPATIAL | SPECTRAL            | SPATIAL | SPECTRAL            | SPECTRAL            | TM SPEC             | SPECTRAL            | SPEC        |
| 1    | 30M       | .45 - .52 $\mu$     | 5-33M   | .46 - .52 $\mu$     | 5-33M   | .46 - .52 $\mu$     | .45 - .52 $\mu$     | .45 - .52 $\mu$     | .45 - .52 $\mu$     | .52 $\mu$   |
| 2    | 30M       | .53 - .61 $\mu$     | 5-33M   | .53 - .60 $\mu$     | 5-33M   | .53 - .60 $\mu$     | .52 - .60 $\mu$     | .52 - .60 $\mu$     | .52 - .60 $\mu$     | .60 $\mu$   |
| 3    | 30M       | .62 - .69 $\mu$     | 5-33M   | .63 - .69 $\mu$     | 5-33M   | .63 - .69 $\mu$     | .63 - .69 $\mu$     | .63 - .69 $\mu$     | .63 - .69 $\mu$     | .69 $\mu$   |
| 4    | 30M       | .78 - .91 $\mu$     | 5-33M   | .77 - .90 $\mu$     | 5-33M   | .77 - .90 $\mu$     | .76 - .90 $\mu$     | .76 - .90 $\mu$     | .76 - .90 $\mu$     | .90 $\mu$   |
| 5    | 30M       | 1.57 - 1.79 $\mu$   | 5-33M   | 1.53 - 1.73 $\mu$   | 5-33M   | 1.53 - 1.73 $\mu$   | 1.55 - 1.75 $\mu$   | 1.55 - 1.75 $\mu$   | 1.55 - 1.75 $\mu$   | 1.75 $\mu$  |
| 7    | 30M       | 2.10 - 2.35 $\mu$   | 5-33M   | 2.06 - 2.33 $\mu$   | 5-33M   | 2.06 - 2.33 $\mu$   | 2.08 - 2.35 $\mu$   | 2.08 - 2.35 $\mu$   | 2.08 - 2.35 $\mu$   | 2.35 $\mu$  |
| 6    | 120M      | 10.40 - 11.60 $\mu$ | 5-131M  | 10.30 - 12.30 $\mu$ | 5-131M  | 10.30 - 12.30 $\mu$ | 10.40 - 12.50 $\mu$ | 10.40 - 12.50 $\mu$ | 10.40 - 12.50 $\mu$ | 12.50 $\mu$ |

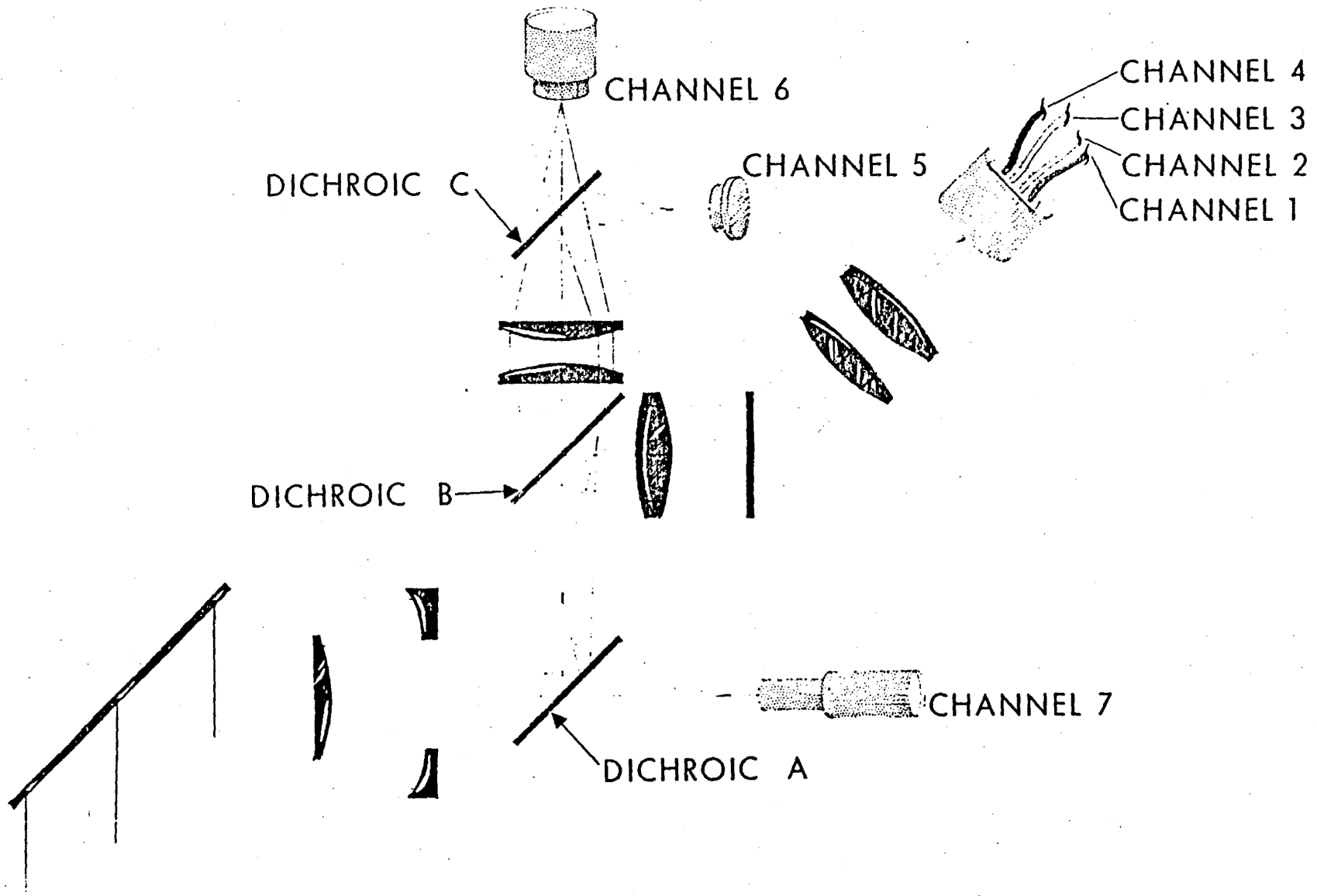

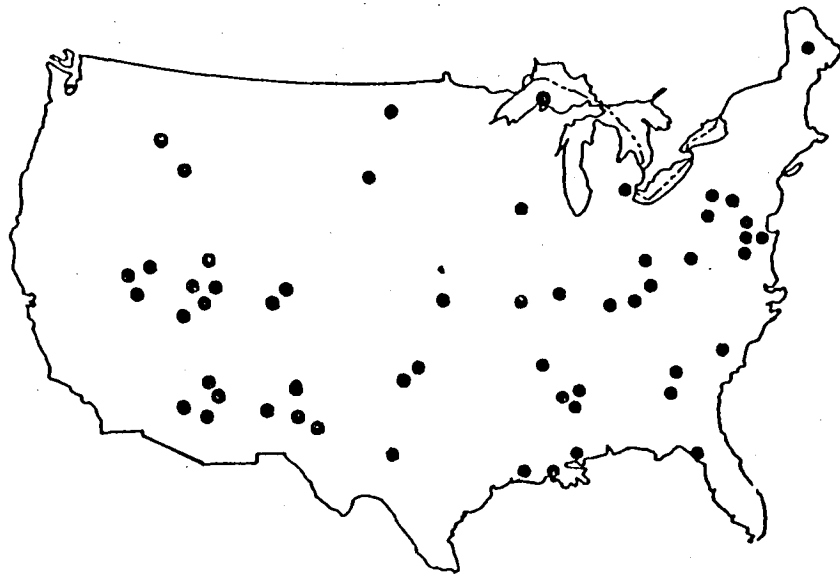

DISTRIBUTION OF FY81 TMS  
DATA ACQUISITION FLIGHTS  
IN CONTINENTAL UNITED STATES

FY81: 86 MISSIONS (7 REIMBURSABLE)  
367 AIRCRAFT FLIGHT HOURS

FY82: (OCT - MAR)  
18 MISSIONS (9 REIMBURSABLE)  
112 AIRCRAFT FLIGHT HOURS

TMS DATA USERS

NASA - NSTL

GSFC (R)

JPL (R)

JSC

DEPT OF STATE

USDA - USFS (R)

USGS - EROS (R)

LOUISIANA STATE UNIVERSITY

MISSISSIPPI STATE UNIVERSITY

MURRAY STATE UNIVERSITY (KY)

OKLAHOMA STATE UNIVERSITY

UNIVERSITY OF GEORGIA

UNIVERSITY OF MICHIGAN (R)

TAC-UNIVERSITY OF NEW MEXICO

WASHINGTON UNIVERSITY (MO)

ST. REGIS PAPER COMPANY

MEXICO (R)

COLOMBIA (R)

LAND COVER CLASSIFICATION ACCURACIES

| <u>SURFACE COVER</u> | <u>TMS ACCURACY (%)</u> |
|----------------------|-------------------------|
| INERT                | 97.62                   |
| OLD FIELDS           | 91.95                   |
| MARSH                | 89.29                   |
| RIVER BOTTOM         | 95.54                   |
| MIXED FOREST         | 92.54                   |
| PINE                 | 91.58                   |
| HAY/GRASS            | 98.19                   |
| WATER                | 100.00                  |
| OVERALL              | 92.30                   |

DATA ACQUIRED OVER PEARL RIVER, MISSISSIPPI TEST SITE WITH NASA TMS.

## THERMAL INFRARED MULTI SPECTRAL SCANNER (TIMS)

- SPECTROMETER DESIGN - JPL/DAEDALUS (AUGUST, 1980 - \$66K)
- SCANNER DESIGN, SPECTROMETER/SCANNER FABRICATION - NSTL/DAEDALUS (DECEMBER, 1980 - \$761K)
- SYSTEM LABORATORY ACCEPTANCE TEST - MAY 10-12, 1982.
- SYSTEM FLIGHT ACCEPTANCE TEST - MAY 13, 1982.
- SCHEDULE:

FLIGHT EVALUATION - MAY 14-24  
 CALIBRATION TESTS - MAY 25 - JULY 18  
 OPERATIONAL FLIGHTS - JULY 19 - AUGUST 1  
 DATA EVALUATION - AUGUST 2-31  
 OPERATIONAL FLIGHTS - SEPTEMBER 1

- SPECIFICATIONS:

|                   |                                      | <u>BAND</u> | <u>SPECTRAL COVERAGE</u>    | <u>NE<math>\Delta</math>T</u> |
|-------------------|--------------------------------------|-------------|-----------------------------|-------------------------------|
| FOCAL LENGTH      | 13.0 INCHES                          | 1           | 8.2 $\mu$ m - 8.6 $\mu$ m   | 0.09 <sup>o</sup> C           |
| CLEAR APERTURE    | 7.5 INCHES                           | 2           | 8.6 $\mu$ m - 9.0 $\mu$ m   | 0.09 <sup>o</sup> C           |
| SYSTEM IFOV       | 2.5 MR                               | 3           | 9.0 $\mu$ m - 9.4 $\mu$ m   | 0.09 <sup>o</sup> C           |
| GROUND RESOLUTION | 5-33 METERS                          | 4           | 9.4 $\mu$ m - 10.2 $\mu$ m  | 0.12 <sup>o</sup> C           |
| SWATH WIDTH       | 1.3 - 8.3 MILES                      | 5           | 10.2 $\mu$ m - 11.2 $\mu$ m | 0.14 <sup>o</sup> C           |
| SCAN SPEEDS       | 7.3, 8.7, 12.0, 25.0<br>SCANS/SECOND | 6           | 11.2 $\mu$ m - 12.2 $\mu$ m | 0.32 <sup>o</sup> C           |

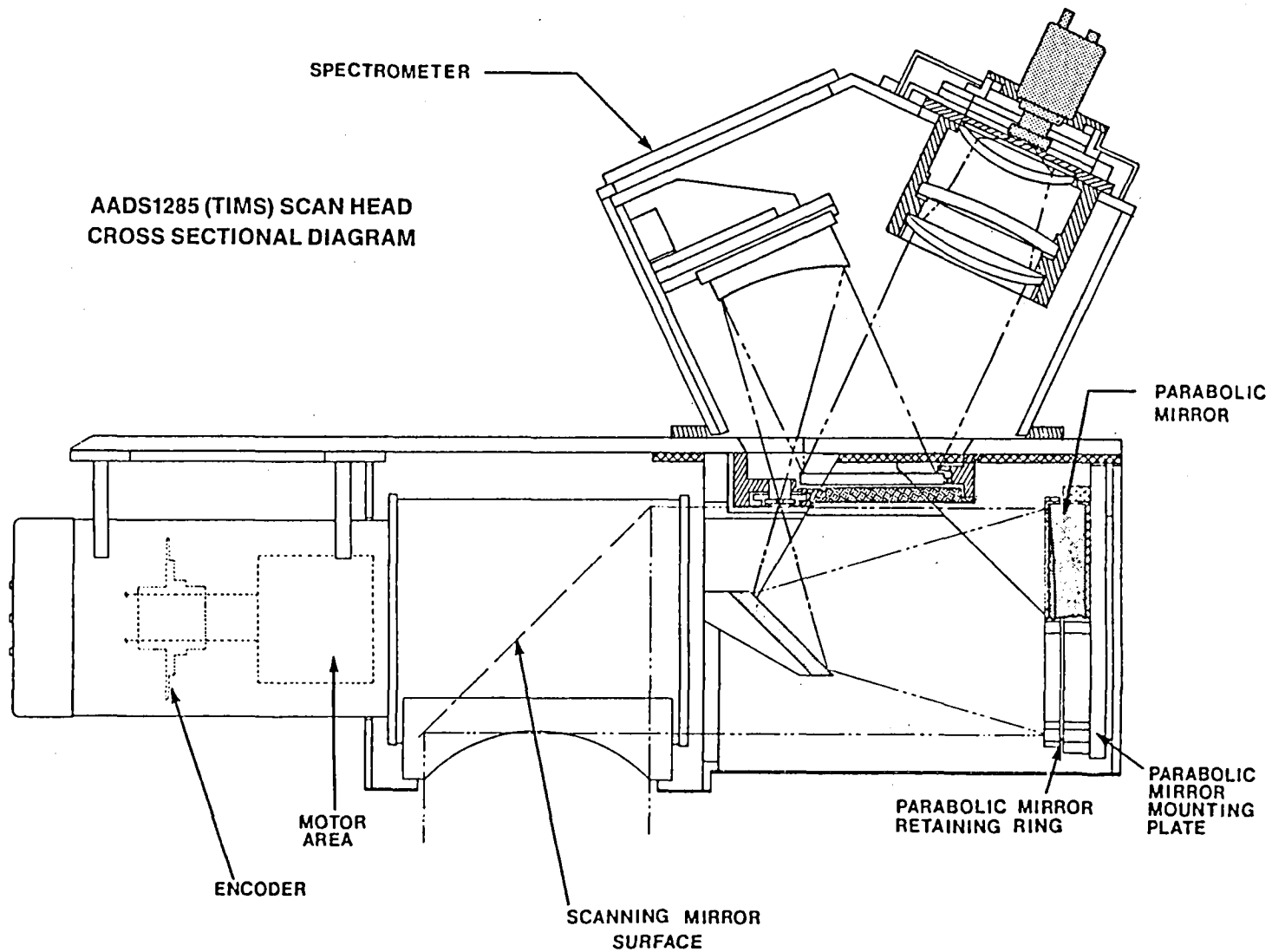

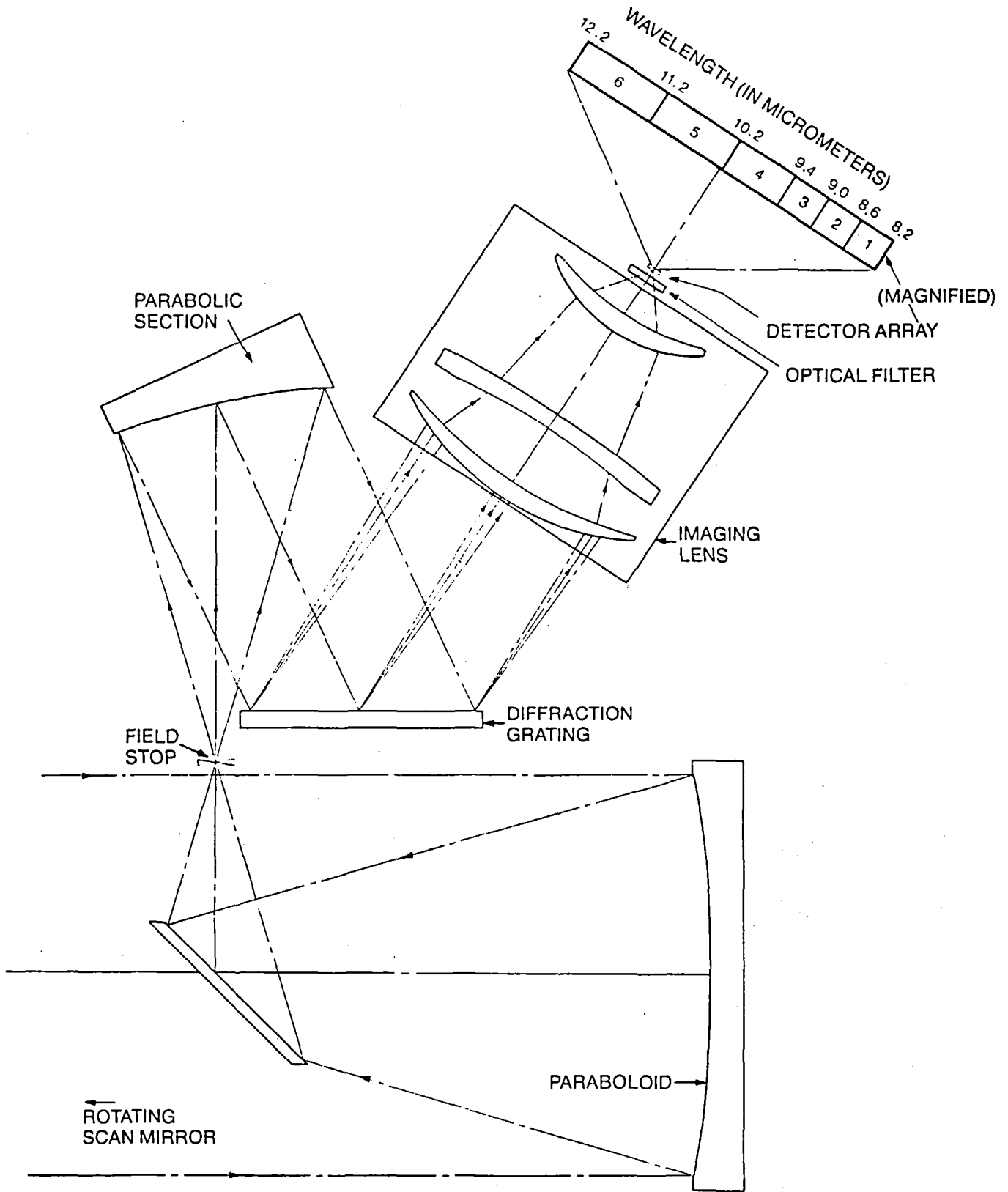



## NSTL SPATIAL RESOLUTION ANALYSIS SYSTEM

- BACKGROUND: 7 BAND TM SIMULATOR DATA WAS ACQUIRED AT 30, 25, 20, 15, 10, AND 5 METER RESOLUTIONS BY OPERATING AIRCRAFT AT DIFFERENT ALTITUDES. ANALYSIS EXTREMELY DIFFICULT DUE TO ATMOSPHERIC PATH LENGTHS AND RESULTING DATA PERTURBATIONS.
- OBJECTIVE: TO DESIGN AND BUILD A VERY LOW COST VARIABLE RESOLUTION (SPATIAL) MULTI-LINEAR ARRAY DEVICE TO PRODUCE 5-30 METER DATA FROM 40,000 FT.
- FEATURES:
  - 4 DISCRETE CHANNELS WITH 512 ELEMENT ARRAYS
  - 3-30 METER RESOLUTION FROM 40,000 FEET
  - FORE-AFT OFF NADIR VIEWING WITH VARIABLE LOOK ANGLE
  - MULTIPLE SPECTRAL BANDPASS FILTER SELECTION
  - ON-BOARD ELECTRONIC ROLL COMPENSATION
  - ON-BOARD ARRAY PARAMETER (RADIOMETRIC) CORRECTION
  - IN-HOUSE DESIGN AND FABRICATION
- FUND SOURCE: DISCRETIONARY FUNDS - \$25 K FOR FLIGHT PROTOTYPE