

## **General Disclaimer**

### **One or more of the Following Statements may affect this Document**

- This document has been reproduced from the best copy furnished by the organizational source. It is being released in the interest of making available as much information as possible.
- This document may contain data, which exceeds the sheet parameters. It was furnished in this condition by the organizational source and is the best copy available.
- This document may contain tone-on-tone or color graphs, charts and/or pictures, which have been reproduced in black and white.
- This document is paginated as submitted by the original source.
- Portions of this document are not fully legible due to the historical nature of some of the material. However, it is the best reproduction available from the original submission.

CR-166829



Made available under NASA sponsorship  
of earth resources survey  
program information and without liability  
for any use made thereof.

E83-10368

INSTITUTE OF FOOD AND AGRICULTURAL SCIENCES  
UNIVERSITY OF FLORIDA

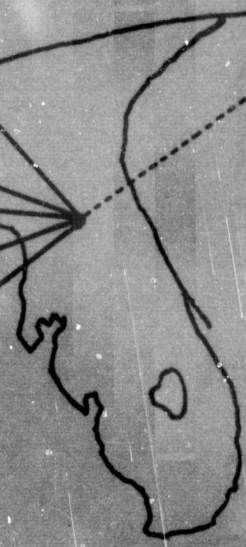
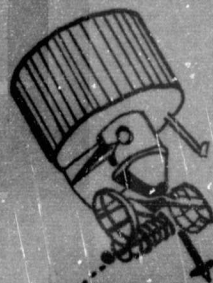
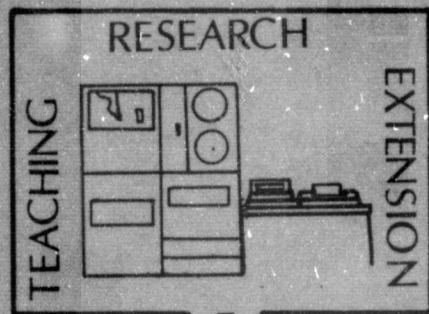
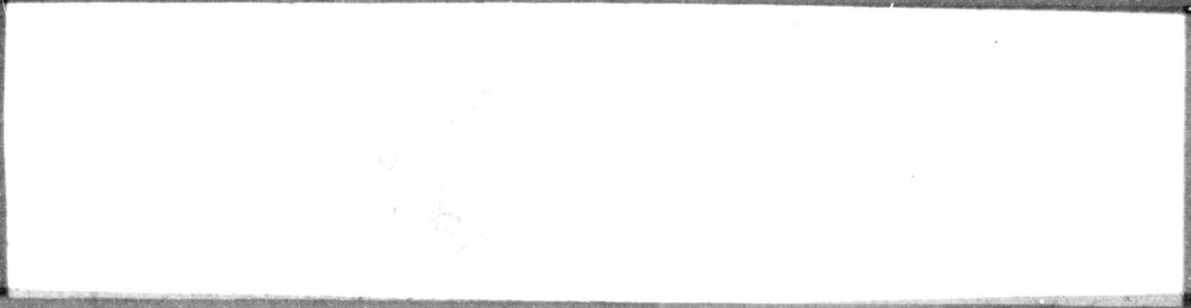

(E83-10368) SATELLITE FREEZE FORECAST  
SYSTEM: EXECUTIVE SUMMARY Final Report  
(Florida Univ.) 24 p HC A02/MF A01 CSCL 04B

N83-29778

Unclas  
G3/43 00368

Original photography may be purchased  
from EROS Data Center  
Sioux Falls, SD 57198

Original photography may be purchased  
from EROS Data Center  
Sioux Falls, SD 57198

EXECUTIVE SUMMARY  
FINAL REPORT  
SATELLITE FREEZE FORECAST SYSTEM  
PHASE VI

SUBMITTED TO  
SI-PRO-33/WILLIAM R. HARRIS  
CONTRACTING OFFICER  
NATIONAL AERONAUTICS AND SPACE ADMINISTRATION  
JOHN F. KENNEDY SPACE CENTER FLORIDA 32899

SUBMITTED BY  
CLIMATOLOGY LABORATORY, FRUIT CROPS DEPARTMENT  
INSTITUTE OF FOOD AND AGRICULTURAL SCIENCES (IFAS)  
2121 HS/PP, UNIVERSITY OF FLORIDA,  
GAINESVILLE, FLORIDA 32611

PRINCIPAL INVESTIGATOR  
J. DAVID MARTSOLF  
PROFESSOR OF CLIMATOLOGY

CONTRACT NO. NAS10-9892  
AMENDMENT NO. 3  
DATE: APRIL 14, 1983

TABLE OF CONTENTS

**FORWARD**..... 1

    Relationship To Other Reports..... 1

    General Acknowledgements..... 5

**INTRODUCTION**..... 6

**SFFS SYSTEM DESCRIPTION**..... 9

    Operational System ..... 9

        Minicomputer System..... 9

        Acquisition Of Satellite Data..... 14

        Automated Telephone Linkages..... 20

        Surface Weather Stations..... 21

        Predicted Products..... 22

    SFFS Development System..... 23

        Minicomputer System..... 23

        Antenna System..... 28

        Product Dissemination..... 32

    Integrated System..... 35

**FUTURE OUTLOOK**..... 36

    Antenna Systems..... 36

    FAST..... 37

    Downlinking GOES..... 37

    Acquisition Of AWS Data..... 38

    Satellite Communications..... 39

ORIGINAL PAGE IS  
OF POOR QUALITY

## LIST OF FIGURES

Figure 1:	Photograph of Operational System, Ruskin .....	10
Figure 2:	Diagram of AWS Components and Linkage .....	11
Figure 3:	Block Diagram of Operational System, Early .....	12
Figure 4:	Block Diagram of Operational System, Late .....	14
Figure 5:	Color Photograph of SFFS Display .....	15
Figure 6:	Antenna in Gainesville .....	27
Figure 7:	Block Diagram of Integrated System .....	29
Figure 8:	Photograph of APPLE II/SFFS Terminal .....	33

## LIST OF TABLES

Table 1:	List of Reports Under Final Contract .....	2
Table 2:	List of Previous NASA/SFFS Contracts .....	3
Table 3:	List of Previous SFFS Reports to NASA .....	4
Table 4:	List of Components of Operational System .....	16
Table 5:	Success Rates GOES Data Acquisition .....	19
Table 6:	List of Locations of AWS .....	22
Table 7:	Component List, Development System .....	25
Table 8:	Component List, Antenna System .....	30

## APPENDICES

Appendix A -	National Climate Program Office Workshop Demonstration Flyer .....	2 pages
Appendix B -	"Personnel and Acknowledgements", one diagram .....	6 pages
Appendix C -	UF President's Advisory Council Demonstration Flyer .....	2 pages
Appendix D -	"Dissemination of Agricultural Weather Information in Florida as Developed through the Satellite Frost Forecast System" Paper to be presented to the National Climate Program Office's Workshop in Tallahassee on March 23, 1983, Copy of submitted manuscript .....	19 pages

ORIGINAL PAGE IS  
OF POOR QUALITY

FOREWORDORIGINAL PAGE IS  
OF POOR QUALITYRelationship Of This Report To Other NASA Reports

This report is the first section of a final report called for by NASA contract, NAS10-9892-Amendment 3, effective date, April 22, 1982. The first two sections of the final report constitute:

1. The Executive Summary
2. Final Report by Tasks

The remaining three sections are SFFS manuals covering:

3. System configuration definition
4. System software documentation
5. System operation and troubleshooting

This report follows a report referred to as the 4th Quarterly Report, SFFS VI, dated November 30, 1982.

The current contract, NAS10-9892-S/A 3, extends the period covered by the NAS10-9892-S/A 2 to 16 months. This makes the new end date March 31, 1983, and this date becomes the effective date of this report. Table 1 lists reports submitted under the final contract, NAS10-9892-S/A 2 & 3.

ORIGINAL PAGE IS  
OF POOR QUALITY

**Table 1.** List of reports submitted under the final contract for the Satellite Freeze Forecast System (SFFS), NAS10-9892, Amendments 2 and 3.

Date	Report Name	Pages
Dec. 31, 1981	Plan and Schedule Milestones	17
Feb. 28, 1982	First Quarterly Report	70
May 31, 1982	Second Quarterly Report	73
Aug. 31, 1982	Mid-Term (Nine Months) Report	82
Nov. 30, 1982	Fourth Quarterly Report	96
Mar. 15, 1983	Final Report, Rough Draft	77
Apr. 14, 1983	Final Report, Executive Summary	39
Apr. 14, 1983	Final Report, Tasks	29
Apr. 14, 1983	System Manual, Configuration	16
Apr. 14, 1983	System Manual, Software	65
Apr. 14, 1983	System Manual, Operating	31
	Total Pages	595

Two previous contracts, NAS10-9892 and NAS10-9892-S/A 1, covered a six month and a ten month period, sequentially. The most recent Amendment, S/A 3, adds 4 months to the 12 month period of NAS10-9892-S/A 2, but Amendment 3 became effective during the contract period for Amendment 2. Essentially, the NAS-9892 series is an extension of a 3-year Contract, NAS10-9168. The relationship between this contract and previous NASA contracts that supported SFFS development is shown in Table 2.

Table 2 indicates only two of eight extensions that took place in NAS10-9168 through which a total of [redacted] was funded. NAS10-9892 totals [redacted] making the grand total received from NASA for SFFS equipment and development under the contracts indicated in Table 2 to be [redacted]. Mr. U. Reed Barnett, NASA/KSC, has indicated that the total development costs have been approximately 1.2 million

ORIGINAL PAGE IS  
OF POOR QUALITY

**Table 2.** Listing of NASA Contracts that have supported SFFS Development.

Short Title	Contract No.	Contract Period
SFFS I	NAS10-9168	10 May 77 -
SFFS II	NAS10-9168 ext.	
SFFS III	NAS10-9168 ext.	- 24 Jul 80
SFFS IV	NAS10-9892	31 Jul 80 - 31 Jan 81
SFFS V	NAS10-9892, A1	1 Jan 80 - 30 Nov 81
SFFS VI	NAS10-9892, A2	1 Dec 81 - 30 Nov 82
SFFS VI cont'd	NAS10-9892, A3	Apr 81 - 31 Mar 83

dollars. This figure likely includes some forerunning and accompanying contracts such as NAS10-8920, NAS10-9611 and NAS10-9876.

The                      should be used with caution since it includes some work sponsored by NASA indicated above not referenced directly as preceding this report. Secondly, it ignores salaries and equipment supplied by IFAS that seemed necessary to the development. The assumption that these two components of the estimate are nearly equal (for they are compensating) is made and such an assumption seems reasonable. Another complication that enters this estimate is caused by the growth of SFFS to include dissemination of SFFS products beyond the NWS forecasters in Ruskin, i.e. to extension agents and growers. The separation of the integrated SFFS into the operational system at Ruskin and the development system at Gainesville brings some order to this complication and avoids a significant portion of the IFAS contribution. This scheme has been followed carefully in preparing this executive summary.



ORIGINAL PAGE IS  
OF POOR QUALITY

The Roman numeral following SFFS in the short title of the various contracts (see Table 2) is an approximate indication of the years of development involved. The development required a period just 25 days less than 6 years.

**Table 3.** Listing of reports submitted under the indicated NASA Contracts covering SFFS I through SFFS V. See Table 1 for SFFS VI reports.

Date	NASA Contract	Report	Short Title	Pages
Sep. 1977	NAS10-9168	SFFS I	First Quarter	8
Dec. 1977	"	"	Second Quarter	*
Apr. 1978	"	"	Third Quarter	52
May 1978	"	"	User's Guide	186
Jun. 1978	"	"	Final	187
Sep. 1978	NAS10-9168	SFFS II	First Quarter	28
Dec. 1978	"	"	Second Quarter	104
Mar. 1978	"	"	Third Quarter	*
Sep. 1979	"	"	Final	107
Oct. 1979	NAS10-9168 S/A 8	SFFS III	First Quarter	56
Jan. 1980	"	"	Second Quarter	92
Apr. 1980	"	"	Third Quarter	138
Jul. 1980	" S/A 9	"	Final	303
Aug. 25, '80	NAS10-9892	SFFS IV	Milestones	31
Nov. 1980	"	"	Mid-term	154
Jan. 1981	"	"	Final	163
Feb. 28, '81	NAS10-9892 S/A 1	SFFS V	Milestones	17
Mar. 1981	"	"	Eval. Plan and lists	28
Aug. 1981	"	"	Mid-term & SFFS Evaluation	85
Nov. 1981	NAS10-9892 S/A 1	SFFS V	Final	142
TOTAL PAGES				1881

\* Report unavailable at time of developing this table.

ORIGINAL PAGE IS  
OF POOR QUALITY

### General Acknowledgements

SFFS has undergone numerous changes during its development and these have been the result of a large number of influences from a long list of contributions to the project. NASA has provided funding through the contracts listed above. UF/IFAS has executed these contracts with cooperation from NOAA/NWS. In that process, IFAS/Research has supported additional work as amendments to and extensions of these contracts. Since NOAA/NWS has accepted the SFFS operational system in December, 1981, they have provided upgrade and maintenance funds for the computer portion of that system as well as encouragement to IFAS to continue to support the effort. For three years IFAS/Extension has supported efforts to disseminate SFFS products to county agricultural agents and recently, the Federal Extension Service arm of USDA supported this effort through Grant 12-05-300-535.

An effort to acknowledge personnel who have developed SFFS or influenced that development in a significant way is appended to this report as Appendix B.

ORIGINAL PAGE IS  
OF POOR QUALITY

### INTRODUCTION

This report documents the completion of a six year project for development of a Satellite Freeze Forecast System (SFSS), its installation in the National Weather Service (NWS) office in Ruskin, Florida, and its operational checkout and implementation in an operational mode. The work was performed by the Institute of Food and Agricultural Sciences (IFAS) at the University of Florida under contract to the NASA Kennedy Space Center, Florida, and in cooperation with the NWS. This project represents the development of remote sensing technology and its application to resource management as authorized under NASA's Earth Resources Management Program. Because elements of this project were consistent with certain goals and objectives of IFAS under its charter, substantial IFAS resources were expended during the conduct of the project in addition to NASA funding.

The primary objective of the project at its inception was the development of a satellite-based temperature monitoring and prediction system and the transfer of that system and its technology to the NWS. The hardware components of that system consist of a computer

ORIGINAL PAGE IS  
OF POOR QUALITY

controlled acquisition, processing, and display system and the ten automated weather stations called by that computer.

Two handouts that document the type of visibility that the system enjoys are attached as Appendices A and C. A copy of a manuscript that has recently been prepared for the National Climate Program Office has been attached as Appendix D because it provides both an abbreviated description of the system and provides a fairly complete list of publications resulting from the project.

SFFS acquires satellite data from either one of two sources, surface data from 10 sites, displays the observed data in the form of color-coded thermal maps and in tables of automated weather station temperatures, computes predicted thermal maps when requested and displays such maps either automatically or manually, archives the data acquired, and makes comparisons with historical data. Except for the last function, SFFS handles these tasks in a highly automated fashion if the user so directs. The predicted thermal maps are the result of two models, one a physical energy budget of the soil and atmosphere interface and the other a statistical relationship between the sites at which the physical model predicts temperatures and each of the pixels of the satellite thermal map.

The primary project objective has been accomplished and that system, called the Operational System is in place and operating at Ruskin, Florida. In the course of developing this system it became

ORIGINAL PAGE IS  
OF POOR QUALITY

apparent that an additional system was required at the IFAS facility in Gainesville, Florida, in order to permit hardware and software development and improvement to proceed in parallel to the system operation, to provide backup and redundant capability, and to minimize logistics problems in system development. That system is called the Development System and is installed and operating in Gainesville, Florida. The functional improvements incorporated in the Development System and its use in conjunction with the Operational System provide greatly enhanced capability in weather monitoring for the state of Florida and that parallel and synergistic operation is called the Integrated System.

The Executive Summary portion of this report and supplemental documentation referenced herein describe those three systems as they now exist at the termination of NASA support for the project. In later sections of the report are contained a discussion of specific task accomplishments during the final phase of the present contract. The evolution of the system configuration and the technical and operational considerations influencing design choices are discussed in detail in prior reports referenced in the Forward of this summary.

ORIGINAL PAGE IS  
OF POOR QUALITY

### SFFS SYSTEM DESCRIPTION

#### The SFFS Operational System

The Operational System is shown as installed in the NWS office at Ruskin, Florida, in Figure 1. The system configuration is shown schematically in Figure 2. The system consists of a central computer and operator control complex at Ruskin including a HP-21MX-M computer with 448 Kbytes of memory. Figure 3 is a block diagram of the operational system as it was envisioned in early stages of development but still represents the system with two exceptions. The operational system now has two sources of GOES data and the dissemination to users other than the NWS forecasters is accomplished through the sister system, the development system, not pictured. A point is that the operational system is a stand-alone system.

#### The Minicomputer System

A list of the components of the operational system is contained in Table 4. The most apparent component of the system is the color monitor on which the color coded thermal maps are displayed. The

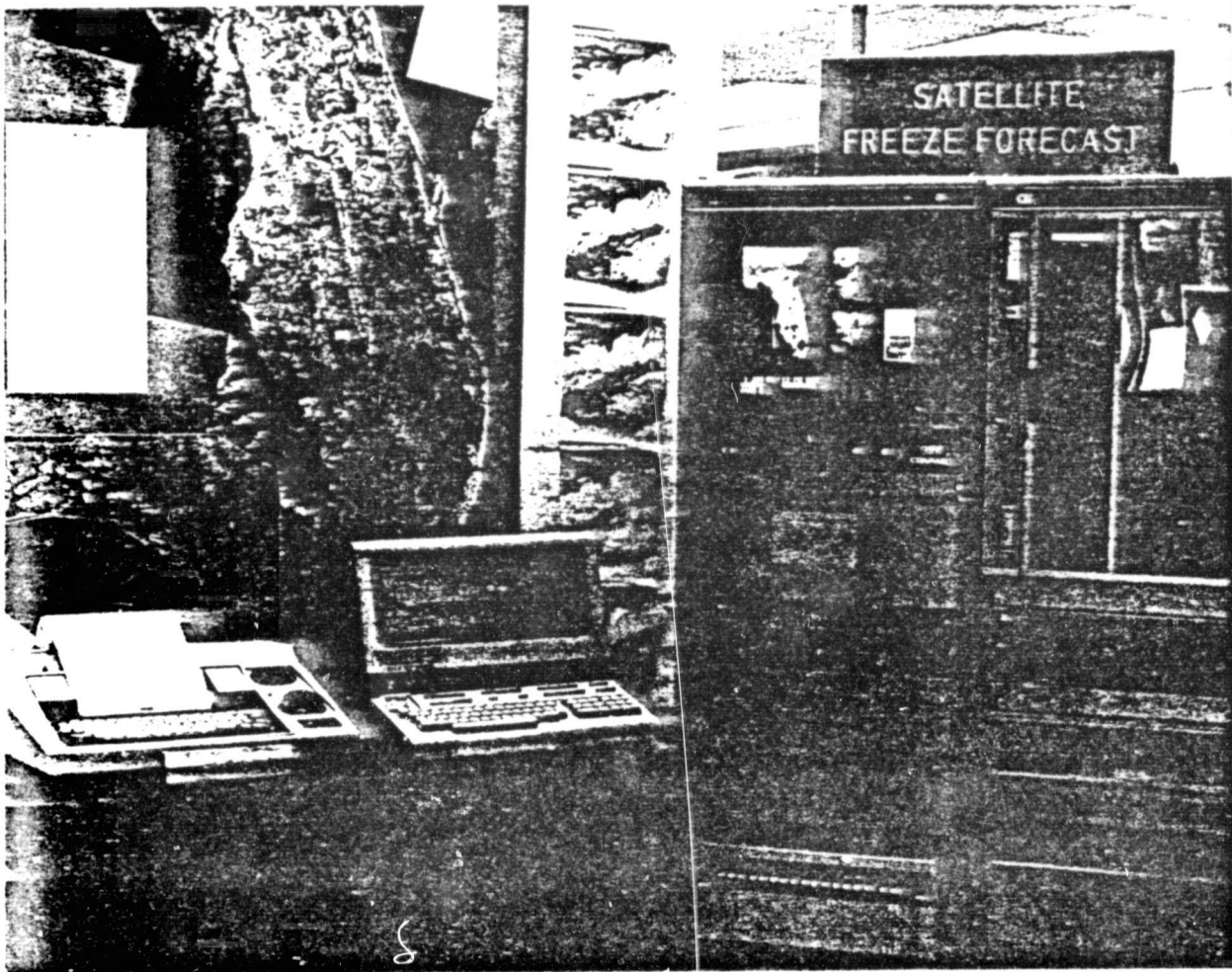

Fig. 1. SFSS Operational System located in National Weather Service Forecast Office in Ruskin, FL. A TI printer/terminal and an HP CRT terminal are visible on left. The Conrac color monitor, HP 21MX M, extender and Vadic modem chassis occupy the left hand rack from top to bottom while a mag tape and 15 megabit disc occupy right hand rack.

monitor is apparent in Figure 1 by noting the nearly white shape of Florida on the darker shaded TV screen near the center of the photograph. The other cathode ray tube (CRT) screen in the system is a part of the main terminal which provides the user with an interface to the system. This is a black and white screen which is used to reveal the exchange of information between the user and the

ORIGINAL PAGE IS  
OF POOR QUALITY

system necessary to the systems use. A printer and key board are apparent to the left in Figure 1. The printer terminal provides a system console record, tabular output of the AWS data and predictions, and by virtue of the keyboard this terminal serves as a back-up the the CRT terminal.

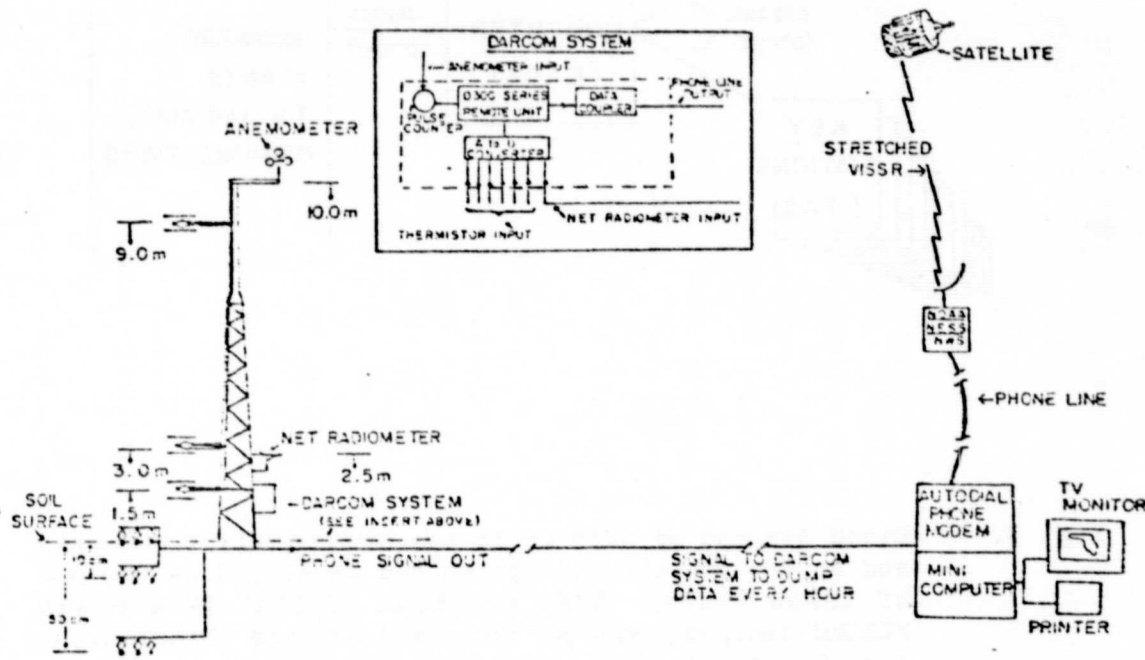

Fig. 2. Diagram of the automatic weather station and its relationship to the SFFS operational system.

SFFS is quite user friendly. Not only is it easy to start and stop but it is simple to manually request one or more optional tasks to be performed while SFFS continues its automatic tasks. For example, a user may sit at the keyboard and re-display the satellite



ORIGINAL PAGE IS  
OF POOR QUALITY

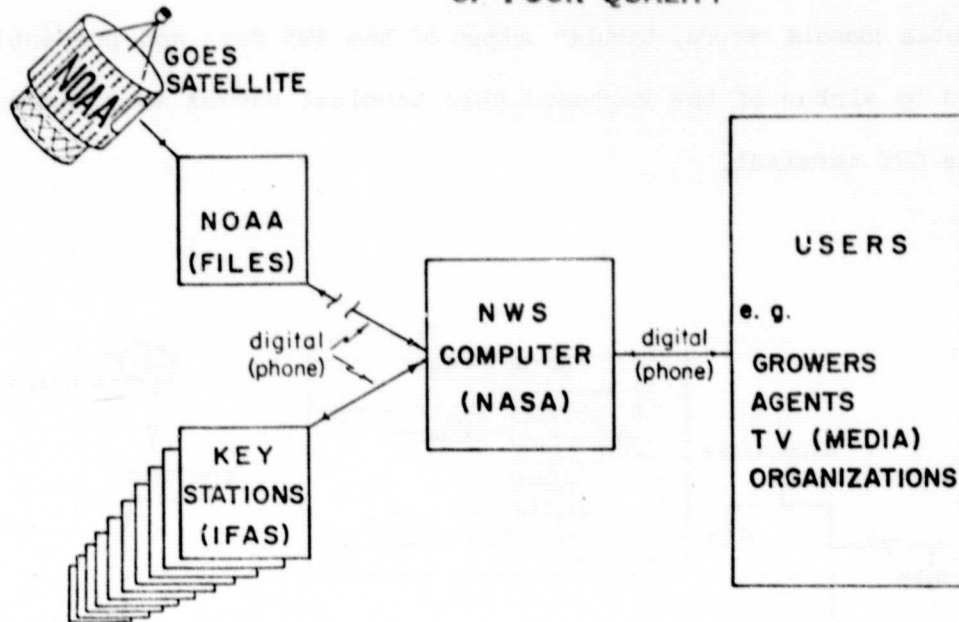

Fig. 3. Block diagram of SFFS as it was originally conceived and as the operational system had developed by the end of three years. SFFS acquired digital IR through NWS/Suitland, MD, once per hour, and surface observations from Key Stations by voice contact with volunteers by phone.

map while changing the temperature limits of the color-coded ranges so that a particular isotherm is revealed. The original name for the system anticipated this facility, the freezeline forecast system. The 32F or 0C line can be displayed as the interface between two of the 8 colors available to the display system. So SFFS operates either automatically or with rapid response to user intervention in

ORIGINAL PAGE IS  
OF POOR QUALITY

a very flexible combination of the manual and automated modes.

The system's operational convenience and flexibility are due, in large part, to the fact that the users (the NWS forecasters) were involved in the system's development and contributed substantially to the system's specification.

SFFS is a computer controlled, weather data acquisition, forecasting, and display system developed especially to aid frost forecasting services provided by the National Weather Service(NWS) of DOC/NOAA. Such service has taken place under an agreement known as the Federal- State Frost Warning Service. Service to the citrus growers and other frost sensitive activities has taken place for more than 40 years through this cooperative agreement between the National Weather Service and the University of Florida's Institute of Food and Agricultural Sciences (IFAS).

The primary elements of SFFS are located prominently, just inside the front door of the Tampa Weather Forecast Office, a relatively new and attractive facility near the agricultural town of Ruskin and approximately 20 miles SSW from the center of Tampa, Florida (see Figure 1). SFFS acquires infrared temperature data from the GOES East satellite (Figures 3 & 4), weather data from ten automated weather stations distributed over peninsular Florida (Fig. 4), and dew point temperatures from AFOS (Fig. 4). SFFS uses this information to create and display color coded thermal maps (both

ORIGINAL PAGE IS  
OF POOR QUALITY

currently observed and predicted) of Florida. Figure 5 is a photograph of the display on the RGB monitor for 6:30 AM EST on January 13, 1983.

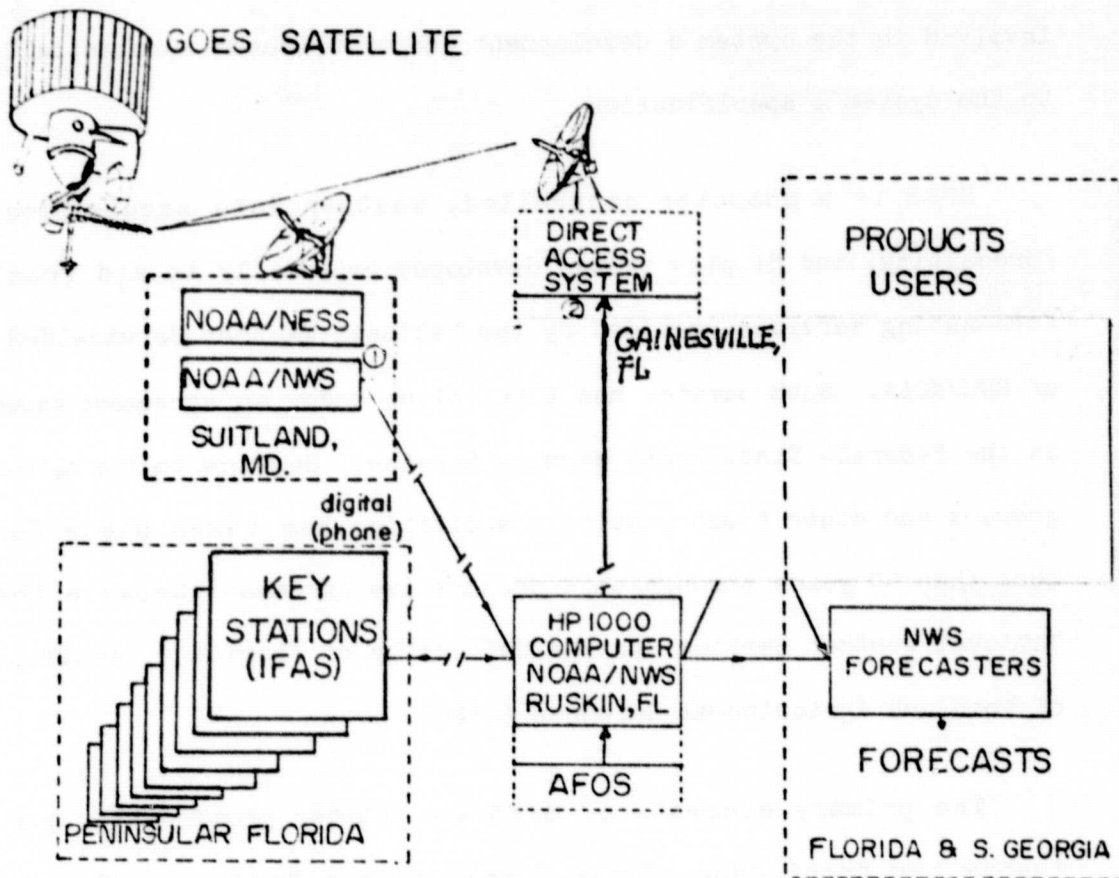

Fig. 4. Block diagram of SFFS Operational System indicating two sources of satellite data, 10 sources of surface weather observations, and product dissemination to the forecasters in Ruskin and to users through their forecasts.

#### Acquisition of Satellite Data

SFFS is primarily a data acquisition system. Data are acquired by telephone, the GOES via a 9600 Baud dedicated link or through a

ORIGINAL PAGE  
COLOR PHOTOGRAPH

Fig. 5. This is a photo of the television screen on which the color coded thermal maps are displayed for a typical but mild frost in 1983.

dial-up 1200 Baud link, and the AWS data via a dial-up 300 Baud link. These modems that permit the system to automatically utilize the phone links to required data bases occupy the space just beneath the minicomputer in the rack housing the color display. The second rack to the right houses the magnetic tape transport and the hard disc system, both of which are necessary to storage and archival of programs, data storage and archival.

SFFS is diagrammed in Figure 4 with related elements from which

ORIGINAL PAGE IS  
OF POOR QUALITY

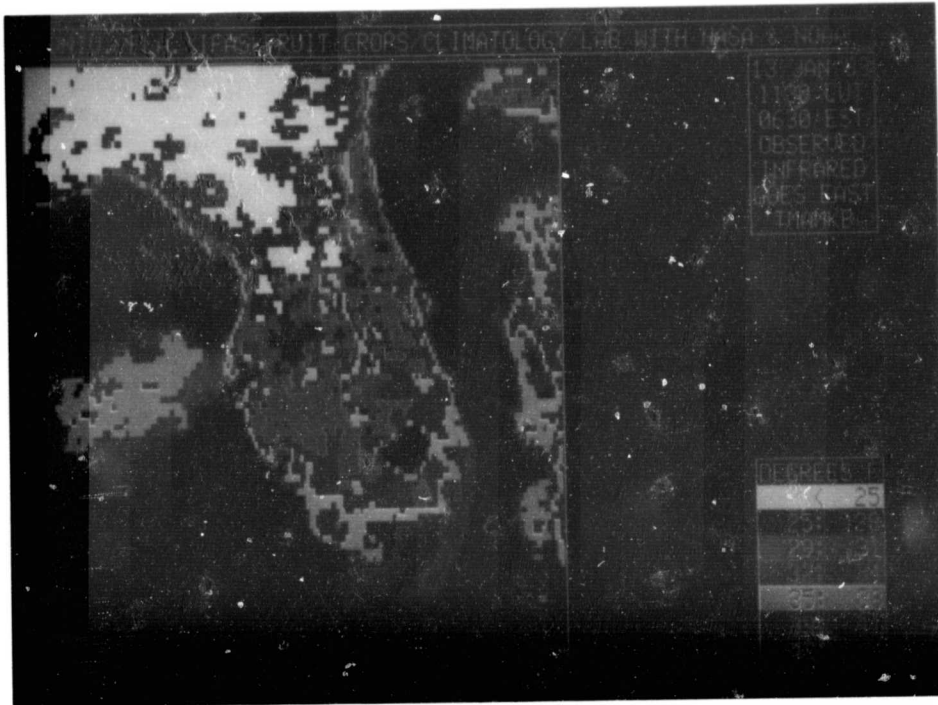
**Table 4.** List of Components of the SFFS Operational System, Ruskin, Fl.

Item	Brief Description
Mini-computer	- Hewlett-Packard Model 2112A (21MX-M) w/448 Kbytes of memory.
Terminal	- HP Model 2645A CRT type w/16 Kbytes of memory and 112 Kbytes of storage on two integrated magnetic tape cassette drives.
Disc	- HP Model 7905A Hard Disc drive with a 15 Mbyte capacity.
Printer	- Texas Instruments Model 733A thermal type, 30 Char./sec. serves as a back-up to the CRT and as the system console.
Tape Drive	- HP Model 7970B magnetic tape drive, 45 in/sec., 800 B.P.I., stores 20 to 24 Mbytes on 2400 inch tape.
TV Monitor	- Conrac Model 5211, a 19 in. high quality RGB color display system. The system is capable of displaying 256 horizontal pixels and 240 vertical pixels in 8 colors.
Modems	- 9600 baud dedicated line to development system in Gainesville as a distributed system. - 1200 Baud full duplex, autodialing for acquisition of satellite data from Suitland, MD. - 300 Baud full duplex, autodialing for calling 10 automatic weather stations.
AFOS Link	- listen only link to the Automated Field Operations System Data General computer through which weather data and forecasts are acquired.

data are acquired or to which products are disseminated. The computer system that is the heart of SFFS and which is pictured in Figure 1 occupies the small box in Figure 4 marked HP 1000 Computer, NOAA/NWS,

ORIGINAL PAGE IS  
OF POOR QUALITY

Ruskin, and which is located in the lower center of the diagram. Satellite data is acquired from NOAA in Suitland via a 1200 bit per second dial-up phone link. Air temperature and soil temperature profiles as well as mean wind speed data are acquired from 10 automated weather stations (sometimes referred to as key stations) by 300 bit per second dial-up phone links. The 10 automated stations and the minicomputer system located in Ruskin comprise SFFS and represent a stand alone system much like the original conception (cf Fig. 3).

Initially SFFS acquired satellite data by redigitizing analog data arriving by GOES-TAP from Miami/NWS on ground line. Concern regarding the effect that the two transformations on the data had on temperature accuracy and the inflexibility introduced by enhancement curves resulted in efforts to acquire the data in its original digital form. The two transformations refer to the digital to analog conversion in Suitland, MD, and the redigitizing of the GOES-TAP signal in Ruskin, FL. This concern was so great that no attempt was made to retain the capability when the possibility of obtaining the digital data directly from Suitland developed. The initial acquisition of data from Suitland via GOES-TAP was a temporary solution to the satellite data acquisition problem and is not recommended for consideration except in cases in which there is no opportunity to obtain the data in its original form. Incidentally, SFFS acquired data via this route very reliably and the resulting

ORIGINAL PAGE IS  
OF POOR QUALITY

products were received with excitement because the redigitizing permitted the creation of much finer (apparent higher resolution) detail than the original data contained. The color maps had a smoother appearance than those that were created directly from the original digital data. The attractiveness of this smoothing or interpolation to many of the viewers of products (and numerous opportunities were found to test the product before potential agricultural users) caused the developers to retain a two-way interpolation option in the SFSS display to this day.

For the final three years of SFSS development, SFSS has had the ability to acquire a Florida sector of the GOES East IR data via a 1200 Baud dial-up telephone link to a port operated by NOAA/NWS in FOB-4, Suitland, Md. Initially, the port was covered by a Vadic modem leased by SFSS but eventually NOAA/NWS took over this responsibility because additional users were given permission to use the port by NOAA/NWS. Concern that the port might be busy when SFSS was attempting to acquire data diminished because the other users apparently exercised the port in the daytime. This port provided access to a queue that was set up by NOAA/NWS especially for SFSS operation. The queue is filled under an experimental priority, i.e. secondary to operational tasks. Consequently, the time that the queue is filled with data from a particular hour is a variable. SFSS is programmed to call and pick up the most recent maps with instructions to check the list of those available against

ORIGINAL PAGE IS  
OF POOR QUALITY

a list of previous acquisitions. Since the maps come in at variable times, SFSS was frequently instructed to call at least twice during an hour and to pick up two maps if necessary. Even with this type of conditional acquisition software the reliability of data acquisition was relatively low and when the data was acquired it was frequently delayed by several hours after the satellite had originally scanned the earth's surface. Table 5 summarizes some of the experience with this method of acquiring satellite data.

**Table 5.** Success rates and average delays experienced by SFSS in acquiring GOES digital data via Suitland, MD.

Period	YR	System	Mean Success Rate	Mean Delay
173 hrs	1981	Development	60%	1.6 hrs
720 hrs	1981	Operational	50%	2.5 hrs
45 hrs	1982	Operational	78%	1.8 hrs
5 hrs	1983	Operational	100%	1.5 hrs

SFSS can be programmed to collect all the satellite data that arrives in the Suitland queue but at considerable telephone cost, i.e. by making numerous calls when data is expected but not received. Consequently the success rates begin to reflect the instances in which the queue is not filled for some reason. As long as SFSS's queue is filled under an experimental priority and the Suitland system's operational requirements remain as large, there seems to



ORIGINAL PAGE IS  
OF POOR QUALITY

be little hope that the reliability would be much greater than 75% and the delays less than one hour. A rather complete study of the channels through which the data had to travel in the Suitland system before becoming available to SFFS provided no expectation that the reliability of this method would increase or that the delay could be appreciably decreased.

Although the use of this link to the satellite data is considered the primary link, data in Table 5 reveals that it is infrequently used. It works well when the operational load on the Suitland computers is relatively light.

#### **Automated Telephone Linkages**

The operating system has two telephone line connection types. One is to a dedicated line through a M96 Paradyne 9600 Baud modem. This is the link over which the distributed system software operates and through which the satellite data is transferred from the development system to the operating system. The second is a series of Vadic modems that plug into a supporting chassis containing a common switching power supply. One of these modems is 1200 Baud full duplex and it handles the link to Suitland. The second modem in this chassis is a 300 Baud full duplex model with which the automated weather stations are called.

These modems are not under maintenance agreements and when

ORIGINAL PAGE IS  
OF POOR QUALITY

there are problems with them the development team generally becomes involved to see if the nature of the problem can be isolated with tests on the computer and with visual observations of the status of the lights on the front of chassis. In the case of the M96 (which belongs to the Climatology Lab and which was obtained through the Communications Division of the Department of General Services of the State of Florida) it is often possible to exchange it temporarily. In the case of the Vadic, a trade with one of the elements from the development system will get the operational system back on line.

#### Surface Weather Stations

The ground Automated Weather Station (AWS) consists of a 10m tower which supports three shielded (top and bottom), naturally aspirated, air temperature sensors at 1.5, 3 and 9 meters; a light-chopper anemometer at 10m; a weatherproof container for the microprocessor controlled data acquisition system and telephone modem; and connections to three soil temperature probes at the soil surface, 10 cm, and 50 cm beneath the surface. Some of the stations have had net pyrradiometers exposed in the past but these were not installed during the 82-83 season. Table 6 declares the locations of the automated weather stations and lists the owner of the land on which they are located. Notice that 4 are on NWS property while the remainder are on IFAS lands. Of the 6 that are on IFAS land, 2 of these are located at Agricultural Extension Centers and 4 are

at branch Agricultural Experiment Stations.

**Table 6.** List of locations of SFFS Automatic Weather Stations with an indication of the affiliation of the cooperator on whose property the station is located.

Station No.	Location	Affiliation
1.	Tallahassee Airport	NWS
2.	Jacksonville Airport	NWS
3.	Gainesville, Horticulture Unit	IFAS
4.	Tavares, Extension Center	IFAS
5.	Ruskin, Weather Forecast Office	NWS
6.	Bartow, Extension Center	IFAS
7.	West Palm Beach Airport	NWS
8.	Belleglade, Experiment Station	IFAS
9.	Immokalee, Experiment Station	IFAS
10.	Homestead, Experiment Station	IFAS

### Predicted Products

Since its conception SFFS was to have forecasting ability. The data from the AWS are required as inputs to the P-model, "P" standing for physical and predictive, which provides forecasted temperatures for each of the AWS sites. Current inputs to P-model include air temperature at 1.5, 3.0 and 9.0m, soil temperature at 0, 10 and 50cm depth, mean wind speed, net radiation, and dew point temperature. A table is generated on the system console which is updated every hour and which contains the observed 1.5m air temperatures and the predicted temperatures from the next hour through 7AM.

The S-model, "S" standing for space and statistical, accepts

ORIGINAL PAGE IS  
OF POOR QUALITY

the forecasted temperatures for each of the 10 AWS sites and uses them in conjunction with the most recent satellite map to produce predicted thermal maps for a given number of hours into the future. The scheduling options provide for the selection of these number of hours, e.g. 1, 3, 5, & 7, may be chosen. The S-model contains a set of coefficients for each pixel that indicates the weight that each AWS prediction will have in the determination of its future temperature. Several sets of coefficients have been produced. For most conditions the distance weighted set seems to work the best. However, these coefficients offer an opportunity for the distribution of temperatures from historic freezes to influence the S-model output.

#### SFFS Development System

The system located in 2116 HS-PP, the Climatology Laboratory of the Fruit Crops Department, UF/IFAS, in Gainesville, has been termed the development system to differentiate it from the operational system located in Ruskin, Florida.

#### Minicomputer System

The development system has a very similar minicomputer to that which controls the operational system, i.e. a Hewlett-Packard 1000

ORIGINAL PAGE IS  
OF POOR QUALITY

Series. The heart of the development system is a HP 21MX-E. The two systems have been purposely kept very similar so that programs developed on the "E" will run with no modification on the "M" (the Ruskin machine). All the statements that have been made about the operational system apply also to the development system, i.e. it can acquire satellite data from Suitland, weather data from the automated weather stations, run the models, display the products and more. It has multiple terminal capability, i.e. a multiplexer that facilitates the programming of the computer from several terminals at the same time. Its printer is better suited to printing out numerous programs, rough drafts of reports, configuration documentation, etc. A plotter is included from which the P-model evaluations have been produced. Table 7 provides a list of components of the development system.

ORIGINAL PAGE IS  
OF POOR QUALITY

**Table 7.** Components of the SFFS Development System, University of Florida, Gainesville, Florida.

Item	Brief Description
Mini-computer	- Hewlett-Packard Model 2113A (21MX-E) with 768 Kbytes of memory
Terminals	- 2 ea. HP Model 2645A w/16 Kbytes of self-contained memory. One terminal has a pair of integrated cassette magnetic tape drives, each with a capacity of 112 Kbytes of storage. - 3 ea HP Model 2621 w/4 Kbytes of memory. One of these contains an integral thermal printer.
System console	- Texas Instruments Model 733A thermal paper type printer.
Discs	- 3 ea. HP Model 7900A discs with 5 Mbyte per disc (2.5 Mbyte of which is removable). - 1 ea HP Model 7912P Winchester type disc with 67.5 Mbyte capacity.
Tape drive	- HP Model 7970B, 800 BPI, 20 to 24 Mbytes per 2400' reel.
Printer	- HP Model 2635A medium duty impact matrix with approx. 180 characters per second speed. A keyboard permits use as a back-up terminal.

ORIGINAL PAGE IS  
OF POOR QUALITY

Table 7 (continued).

---

Television display	- Conrac Model RHM-19, 19 in. TV monitor from NASA, RGB, capable of displaying 786 horizontal pixels and 480 vertical pixels in 8 colors. An additional white over-lay channel is non-destructive to under-lain colors. This display system is an Intermedia model 4601. Additionally a Hewlett-Packard model 91200B system drives a Panasonic model CT-1910M monitor displaying 256 horizontal pixels and 240 vertical pixels. The HP system emulates the Ruskin display system.
Plotter	- HP Model 7210 single-pen with a resolution of 100 points per in.
Modems	- 1 ea. 9600 Baud dedicated line modem serving the other half of the distributed system link with the Ruskin machine, Paradyne model M96. - 1 ea. 300 Baud full duplex autodial modems integrated in a Vadic chassis. - 2 ea. 300 Baud full duplex answer-only modem in same chassis. - 1 ea. 1200 Baud full duplex autodial modem in same chassis. - 1 ea. 300/1200 Baud full duplex answer-only auto speed detection modem in same chassis.
Antenna interface	- HP 12566 data interface card and lab developed and installed hand-shaking signal producing circuits.

---

ORIGINAL PAGE IS  
OF POOR QUALITY

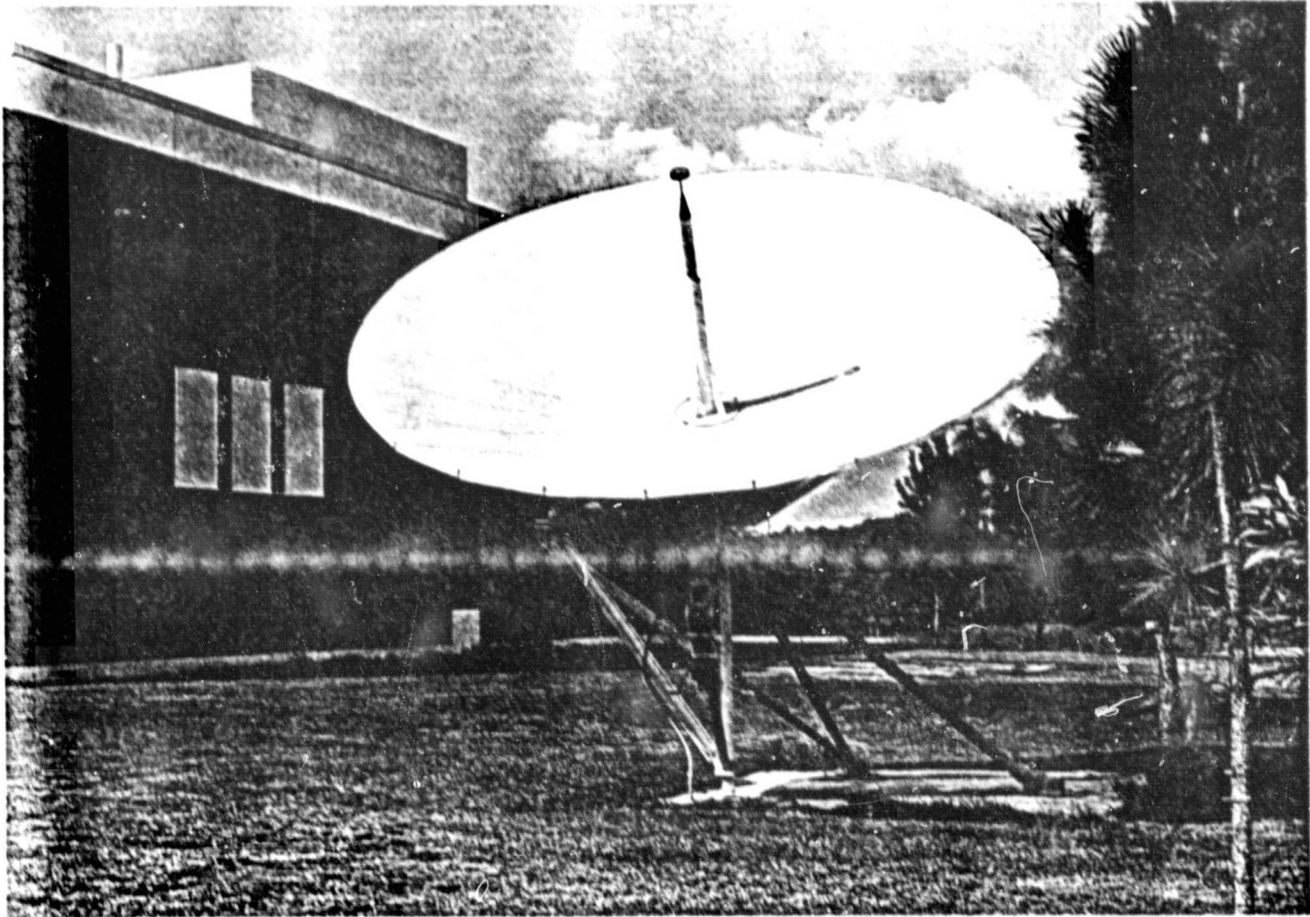

Fig. 6. SFFS direct downlink from GOES located just East of HS/PP Bldg. on the UF Campus in Gainesville, Florida.

Recently, in order to facilitate the interface with the antenna system (see Fig. 6), the "E" has been upgraded to a virtual memory operating system called RTE-6/VM. A Winchester disc has been added to bring the total disc space to 80 megabytes. The antenna system was installed in November of 1981 and the interfacing to the development system became operational on February 22, 1982. Since its installation the antenna system has been operated 24 hours/day,



ORIGINAL PAGE IS  
OF POOR QUALITY

7 days/week to test its reliability. It is estimated that the antenna has been inoperative for less than 50 hours due to a failure of a component of the antenna system. A view of the 5 meter dish is shown in Figure 6.

The development system exists in a laboratory environment and is, consequently, in a rather constant state of change. Experiments are in progress daily to expand and refine the downlink, expedite the exchange of satellite data and AFOS products with Ruskin, improve the products stored in queues in the IFAS Computer Network VAX, and provide experimental links with potential users of the SFFS like products (Fig. 7).

Currently, the development system has two operational tasks:

1. Downlink GOES-EAST stretched VISSR IR for SFFS and communicate the satellite data to Ruskin and
2. Disseminate SFFS products beyond the NWS Forecasters through the IFAS Computer System.

### Antenna System

The secondary manner in which SFFS acquires GOES EAST IR data is through the antenna system via the development system in Gainesville. The antenna system has been described in previous reports in some detail. It consists of a 5-meter dish, a low noise

ORIGINAL PAGE IS  
OF POOR QUALITY

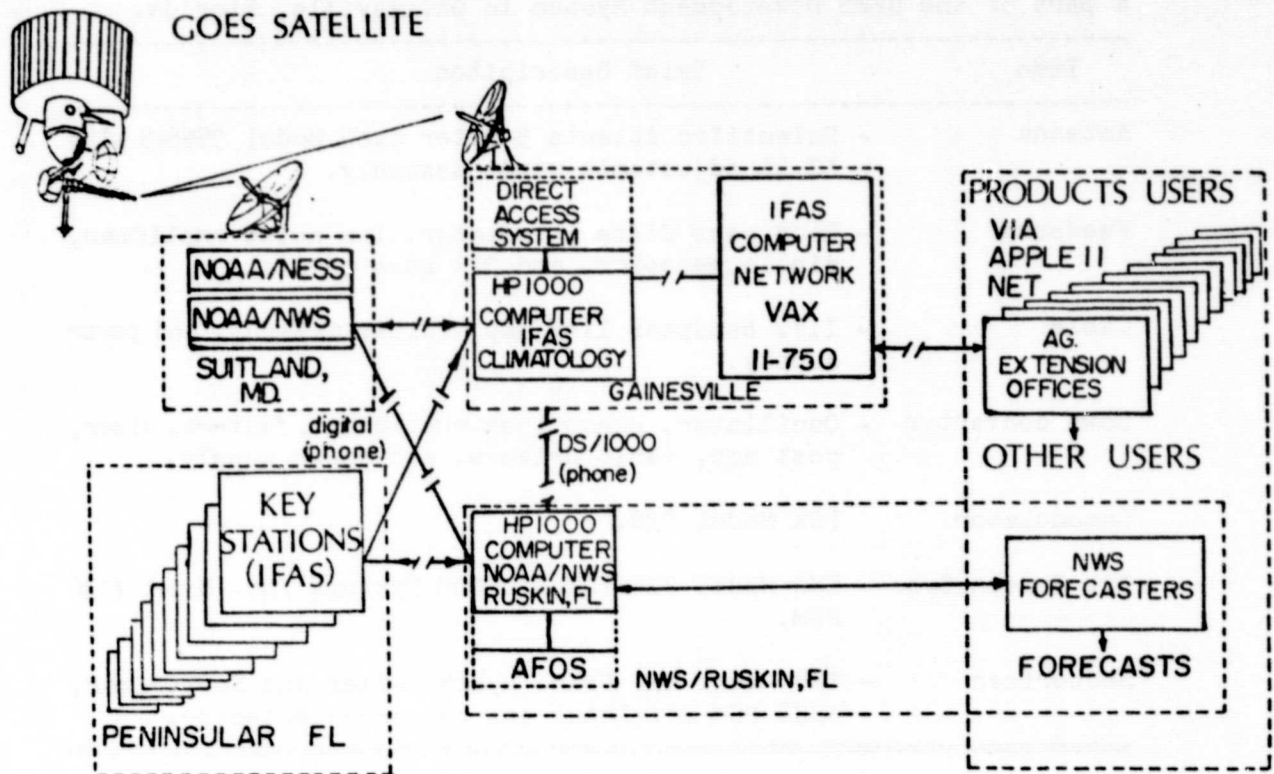

Fig. 7. Block diagram of the components of the Integrated SFFS System with the exception of the newest component FAST which may be placed above the the SFFS Antenna System (Direct Access System) and be interfaced initially with that antenna and to the development system (i.e. Climatology).

amplifier (LNA), a down converter, a demodulator, a transmission line with line drivers, two bit synchronizers and a sectorizer. The output from the sectorizer is interfaced with a interface card to the development system minicomputer referred to as the "E". Table 8. provides a list of the components of the antenna system.

ORIGINAL PAGE IS  
OF POOR QUALITY

**Table 8.** List of components of the Direct Downlink Antenna System, a part of the SFFS Development System in Gainesville, Florida.

Item	Brief Description
Antenna	- Scientific Atlanta 5 meter dish Model 3556-5 with AZ-EL adjustable mount assembly.
Feedhorn	- Band pass filter, isolator, low noise amplifier, dipole receptor, and 1/4 wave cavity.
Cable	- I.F. bandpass line amp, filter assembly, and power supply.
Down converter	- Oscillator, phase lock multiplier, filters, mixer, post amp, cable drivers, and power supply.
Demodulator	PSK Model 728.
Bit Stream Sync	- EMR Model 720 PCM & DECOM Systems Inc. Model 7136 PCM.
Sectorizer	- EMR Model 822 Frame synchronizer and Sectorizer, GOES PCM Simulator and bit error detector.

There are several advantages to this link over the Suitland link:

1. The link is more reliable. There have only been a matter of hours of down time since the antenna was first interfaced on Feb. 22, 1982, and some of these were caused by experiments on the system.
2. The delay is reduced to zero. The Florida sector is available to SFFS approximately 6 minutes after the hour and after the half-hour.
3. Data is available twice as frequently. The antenna provides IR data every half hour whereas the Suitland system made no

ORIGINAL PAGE IS  
OF POOR QUALITY

- attempt to link the half hour data to the Florida queue.
4. Also, twice as much apparent resolution is available, i.e. the IR data comes down from both the IR sensors.
  5. The data comes down in binary, i.e. there are 256 individual temperature steps of 0.5C. The data from Suitland has been translated into ASCII characters. Since there are only 92 characters, the temperature range must be truncated. This led to the less than 14F truncation in the freeze maps for 1981 and 1982 when unusually cold temperatures occurred in Florida and were below the resolution of the Suitland data.

The major disadvantage of the downlink is that it cost about \$40,000 for equipment initially, and approximately \$30,000 in redundant equipment has been acquired to increase its reliability since its installation. Without the redundancy, a new antenna with the same capability would cost about \$75,000. The cost of installing and operating the antenna has been roughly estimated \$35,000 per year, with the cost of maintaining personnel expertise being the most difficult portion of this cost to estimate.

Since February 22, 1982, the development system has been very reliable in its downlink of GOES-EAST IR data. It has continuously performed this task to provide an estimate of the reliability of

ORIGINAL PAGE IS  
OF POOR QUALITY

such a link. The reliability is surprisingly high since the down time has been a matter of hours during a period in excess of one year. Some of the down time that occurred was due to experiments with the link to bring visible data down. Currently, the development system is capable of downlinking either Visible or infrared data but not both at the same time. During the Fall of 1982, a decision was made to disseminate SFFS products to the Agricultural Extension Agents that make up the APPLE Network through the IFAS Computer System (Figs. 7 and 8). As the frost season continued the development system became more and more effective in passing to the IFAS Computer System the Florida sector of the IR data on a routine basis. That effort continued through the winter and is still in effect at the time of writing this report. The reliability of the link from the development HP to the IFAS VAX is nearly as great as that for the downlink itself, i.e. the antenna system plus the development system.

The dissemination of SFFS products to users beyond the forecasters now occurs from the development system through the IFAS VAX and to the extension agents of the APPLE Network.

#### **Product Dissemination**

The SFFS development system disseminates SFFS products by two routes. One of these is clearly indicated in Figure 7 and it involves the IFAS Computer Network VAX 11-750 super minicomputer. This is

ORIGINAL PAGE  
COLOR PHOTOGRAPH

Fig. 8. Apple II Plus used as a SFFS terminal. Two disc drives, a clock, a software controlled modem, and a color monitor are needed for a complete system capable of automatic data acquisition, display and archival.

the primary route to the county agricultural agents that cooperate as members of what has been called the SFFS APPLE Network. These members are no longer restricted to the APPLE II Plus (Fig. 8) as a SFFS terminal and this name is slipping into non-use. There are now more than 10 county offices that have the ability to interrogate the IFAS VAX for SFFS products. The SFFS development system automatically feeds these products to the IFAS VAX by calling over a 1200 Baud telephone link much like the one that is made between the SFFS minicomputer and the Suitland port, except that the Florida

ORIGINAL PAGE IS  
OF POOR QUALITY

sector moves from SFFS to VAX rather than the other direction. The APPLE software has been modified to permit IFAS users to interrogate the VAX automatically just as they used to call ports in the development system. Currently, these IFAS users retain the ability to operate through the SFFS development minicomputer directly if the VAX is inoperative.

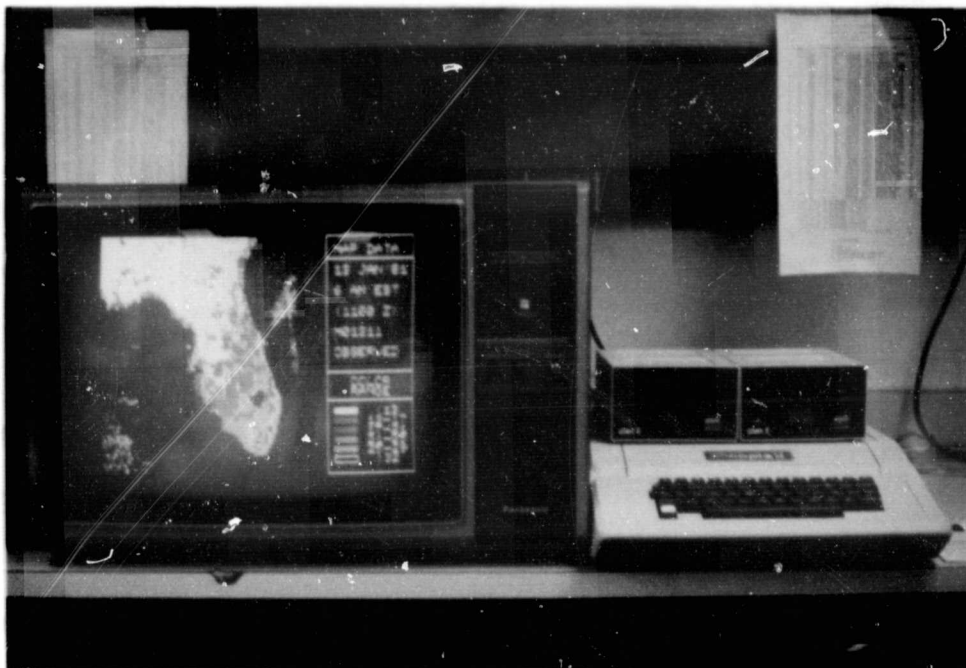
Policy restricts IFAS VAX use to IFAS personnel. Consequently, all non-IFAS users continue to access the SFFS products through the SFFS development system directly. These users all operate under an "experimental label", i.e. they are considered part of an experiment with such communications. These users researchers in other universities, a few television stations, and a few members of the private sector (mostly out of state). A policy is followed that indicates that the path to this information by computer link is through the county agent's microcomputer. Lake County has expanded to a hard disk system to accommodate 10 growers who are members of that network. Other counties have designated a privately owned microcomputer as the county computer to permit experiments to take place with the products.

The microcomputers that can acquire SFFS products and display them have increased to include the IBM PC and the Zenith Z-100. Software for these machines have been developed with help from a new organization known as FAST (see comments in Future Outlook

section of this report).

ORIGINAL PAGE IS  
OF POOR QUALITY

### **The Integrated System**

The combined system as it is frequently presented is shown in Figure 7. There are several advantages. Either system can acquire the satellite data from Suitland and either system can acquire the automated weather station data.

In the latter case, a recent change in the phone system on campus makes it impossible for the Gainesville system to call the automated weather stations on any network except Suncom. The line quality of Suncom is so much lower than normal phone connections that the programs that control AWS must run longer and make more tries to run to equal performance rates that can be achieved from the Ruskin system.

The coordination between the operational team in Ruskin and the development team in Gainesville across the 9600 Baud dedicated line via the distributed system (DS/1000-VM) increases with experience. Satellite data flows to Ruskin and AFOS data flows to Gainesville. Information exchange between operators is facilitated by software that permits the display of a message on the screen at the other location interactively when both parties to the communication are responding.



ORIGINAL PAGE IS  
OF POOR QUALITY

## FUTURE OUTLOOK

### Antenna Systems

So far, only the Gainesville system can downlink GOES. However, there are possibilities that either or both the Ruskin system and the FAST system will acquire this capability in the future. Only the Ruskin system can interface AFOS because of its location and of course it must be operational to present the products to the forecasters there. Currently, only the development system disseminates products beyond the forecaster. There has been a untested policy voiced by NWS that their system, the operational system, is not to be used for dissemination. If this policy is revised the Ruskin system could load some of the county APPLES directly or load the IFAS VAX which in turn provides ports for the county APPLES. The IFAS computer operates under a policy that only IFAS program personnel can acquire an account. Consequently, the few non-IFAS accounts for SFFS products are serviced directly from the development system in Gainesville under an "experimental label."

FASTORIGINAL PAGE IS  
OF POOR QUALITY

The Florida Agricultural Services and Technology corporation came into existence in January 1983. It seems quite likely that FAST will take over the operational tasks that the development system has accumulated. FAST is not drawn in the diagram of SFFS in Figure 7 because the CDC Cyber 730 that is to constitute the main computer in the FAST system is not expected to be in place until a couple of weeks following the effective date of this report. It is expected to quickly become a portion of the integrated system and as time passes it will rise to the prominent position in the integrated system. There are likely to be links with the development system and through it to the operational system.

Downlinking GOES

If FAST takes over the operational task of downlinking GOES there must be effective links with the IFAS VAX and with the operational system in Ruskin since both of these systems require satellite data in real time. It is unlikely that FAST will operate the downlink without first providing assurance that those current users of GOES IR would be able to continue such uses.

Part of this investment in the downlink is justified by the realization that the antenna downlinks visible as well as infrared data. These data have potential in water management and marine

programs in the future.

ORIGINAL PAGE IS  
OF POOR QUALITY

WEFAX data also comes down through the antenna and it seems to provide an alternative source for much of the material that AFOS transmits. In a broadened agricultural weather information system such as FAST many of these products are expected to find application.

#### Acquisition of Automated Weather Station Data

Previously in this report the ten automated weather stations (AWS) have been listed along with their affiliation (Table 6). Three years ago these stations made the transition from manual (voice over telephone) to automatic (microprocessor-computer telephone connection under software control) by the addition of Darcom data acquisition systems at the stations.

With the end of NASA support for SFFS an effort has been made to support each AWS locally. First, the two home stations, i.e. the one at Ruskin and the one in Gainesville are to be maintained locally by the NWS operational team and the IFAS development team respectively. Secondly, the two County Extension Center stations are to be integrated into automated stations served by microcomputers (APPLE II's) that are located near the station prior to the 83-84 season. These two stations are overseen by Mr. Tom Oswalt and Mr. John L. Jackson, both veteran cooperators with SFFS development. These stations are located at Tavares and Bartow. Of the remaining

ORIGINAL PAGE IS  
OF POOR QUALITY

6 stations, 3 are on IFAS turf and 3 on NWS land. NOAA/NWS has picked up the telephone line charges for their 3 and each of the branch experiment stations (IFAS) has taken over the line costs as of the end of March, 1984. In summary, the AWS network continues to exist in a cooperative arrangement with the local participants.

An effort is in progress to have the participants retrieve the sensors and the Darcoms and store them locally until next Fall. An instruction sheet has been developed for retrieval and installation and will become part of the SFSS manual.

#### Satellite Communications

Several grant proposals are in progress. One has been mentioned previously which is a cooperative effort between IFAS and the Communications Division of the Department of General Services of the State of Florida to provide up and downlinks to satellites in both the weather and the general communications areas. Another proposal involves the development of satellite, radar, and lightning data communication links to aid in the management of water resources by the Water Management Districts of Florida. NASA/KSC has shown some interest in this effort because of possibilities of the provision of both research and data transmission links important to the space shuttle landing mission.

Appendix A

AGRICULTURAL WEATHER INFORMATION DISSEMINATION IN FLORIDA<sup>1</sup>

Florida agriculturists benefit from space-age technology applied to a much older problem for those who farm in the Florida climate--the occasional frost or freeze. Color-coded thermal maps of the Florida peninsula were printed on the covers of the April issues (1981 & 1982) of the Florida Grower & Rancher (Vols. 74 & 75), as well as on the cover of the October, 1981 HortScience (Vol. 16:586) and in the Institute of Food and Agricultural Sciences (IFAS) Fruit Crops Fact Sheet 68. They document the freezes of January 13, 1981 and January 12, 1982 and serve as examples of products from the Satellite Frost Forecast System (SFFS).

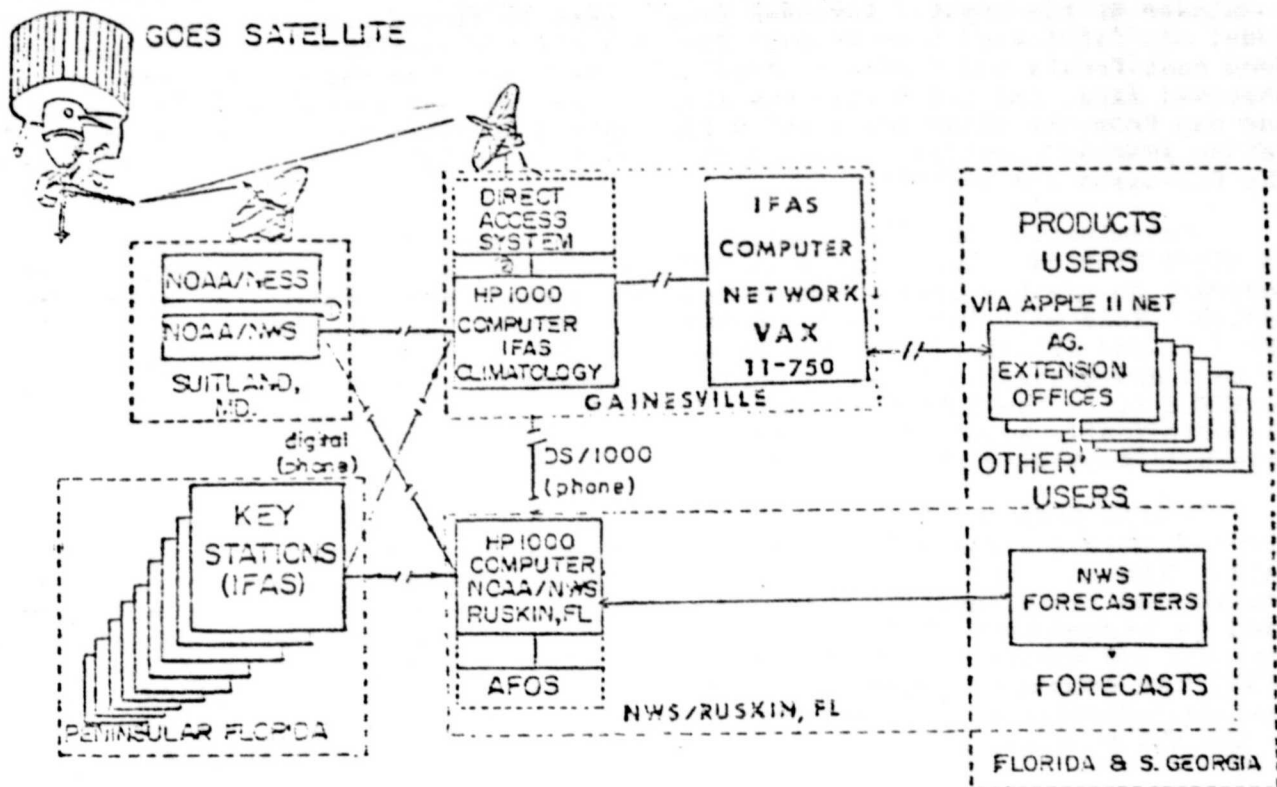

Block diagram of SFFS as it operated during the Winter of 1982-83, emphasizing the communication linkages.

<sup>1</sup>Prepared for the National Climate Program Office sponsored Conference and Workshop, Tallahassee, FL, 22-24 March 1983 by J. David Martsolf, Professor of Climatology, and Paul H. Heinemann, Doctorate Candidate, Fruit Crops Dept., IFAS, Univ. of Fla., Gainesville, FL 32611.

SFFS has been developed by the Climatology Laboratory of the Fruit Crops Department of the Institute of Food and Agricultural Sciences (IFAS) of the University of Florida with support from the National Aeronautics and Space Administration (NASA). SFFS acquires satellite sensed temperatures from the eastern Geostationary Operational Environmental Satellite (GOES) operated by the National Earth Satellite Service, National Oceanic and Atmospheric Administration (NOAA) of the Department of Commerce. Instructions within a NASA-supplied minicomputer, the heart of SFFS, partition the temperature data into color bands and cause the resulting map to be displayed on a color TV screen within minutes of the reception of the satellite data.

SFFS not only acquires temperatures from GOES to display thermal maps in color but also schedules programs which predict future temperatures during the frost night. A sister minicomputer in Ruskin interrogates via telephone 10 automated weather stations (called key stations on the block diagram) over the peninsula of Florida to acquire air temperature, soil temperature, wind speed and net radiation. These data are used by a model that solves the surface energy budget equation at each site. The model predicts the temperature fall at each of the ten sites for the remainder of the night. A second model takes predicted temperatures from the first model and fabricates thermal maps for each night by recalling the temperature patterns from past frosts and freezes. Prediction maps have the same configuration as the observed maps, and the system can display the two maps side by side. It can subtract one map from the other and display temperature differences as a third map. This latter process provides an excellent test of the predictability of the models as the forecasts are verified.

Dissemination of SFFS products currently occurs through an experimental network to eight Florida County Extension Offices and one in southern Georgia. Efforts are underway to use the IFAS Computer Network to provide dissemination ports for the system. This will increase the number of ports that IFAS personnel may call with APPLE II and III microcomputers to acquire SFFS products. An experiment took place in Lake and Orange Counties in which 10 growers received satellite views by calling an APPLE II in the Extension Center in Tavares. One commercial television station is periodically acquiring the products on an experimental basis and several stations have been following the development with interest.

Several products have been disseminated that do not require display by the microcomputer and color TV. One is a black-and-white printout of satellite map data. The map uses symbols which can be equated back to temperature through a translation table incorporated in the printout. These records of the freeze are used in assessment of frost damage and in modifying harvesting decisions. Such products are easily and rapidly copied for distribution. Recently, a link with AFOS, the computer controlled communication network used by NOAA/NWS to handle weather information, has been developed to pass the frost warning bulletins developed by the NWS forecast office in Ruskin to the SFFS network (see diagram).

SFFS has served as a forerunner to Florida Agricultural Science and Technology (FAST), a not-for-profit corporation that proposes to disseminate products like those demonstrated by SFFS but covering the broad area of agricultural weather and climate information. SFFS is serving as an experimental tool in feasibility studies related to acquisition of radar and AFOS data, in anticipation of products that describe precipitation, evapotranspiration and severe weather patterns in much the same way SFFS displays frost hazards. Agriculturists in Florida should have opportunities to display highly tailored weather and climate products on color TV monitors driven by microcomputers interrogating data bases in the IFAS computer network and FAST. Such rapidly communicated products are likely to aid agriculturists, and resource managers in general, to more efficiently and effectively utilize the most valuable resource in Florida, its climate.

Appendix B



APPENDIX B

ORIGINAL PAGE IS  
OF POOR QUALITY

ACKNOWLEDGEMENTS

The forward of this report contains acknowledgements of the NASA Contracts and the single USDA/Extension Grant that has supported this work and a closely related activity. This Appendix contains acknowledgements to many of a relatively large number of individuals and team members who have in some way made significant contributions to the development of SFFS. The acknowledgements are in no way exhaustive and this is especially true for cases in the early stages of the development. For these deficiencies, the author of this appendix apologizes.

Personnel

In general, the Climatology Laboratory personnel of the Fruit Crops Department of the Institute of Food and Agricultural Sciences of the University of Florida, Gainesville, Florida, has taken responsibility for the development of SFFS as a unit. Figure 1 provides an organizational chart of that Laboratory with personnel indicated that filled the positions in many cases throughout the SFFS development and in some cases only for periods extending from late 1982 to the present. Some of the personnel indicated in figure 1 worked with NASA support while others were supported by IFAS salaries or with funds from other grants. The core of the team: the PI, the systems analyst, and the engineers, remain on IFAS

ORIGINAL PAGE IS  
OF POOR QUALITY

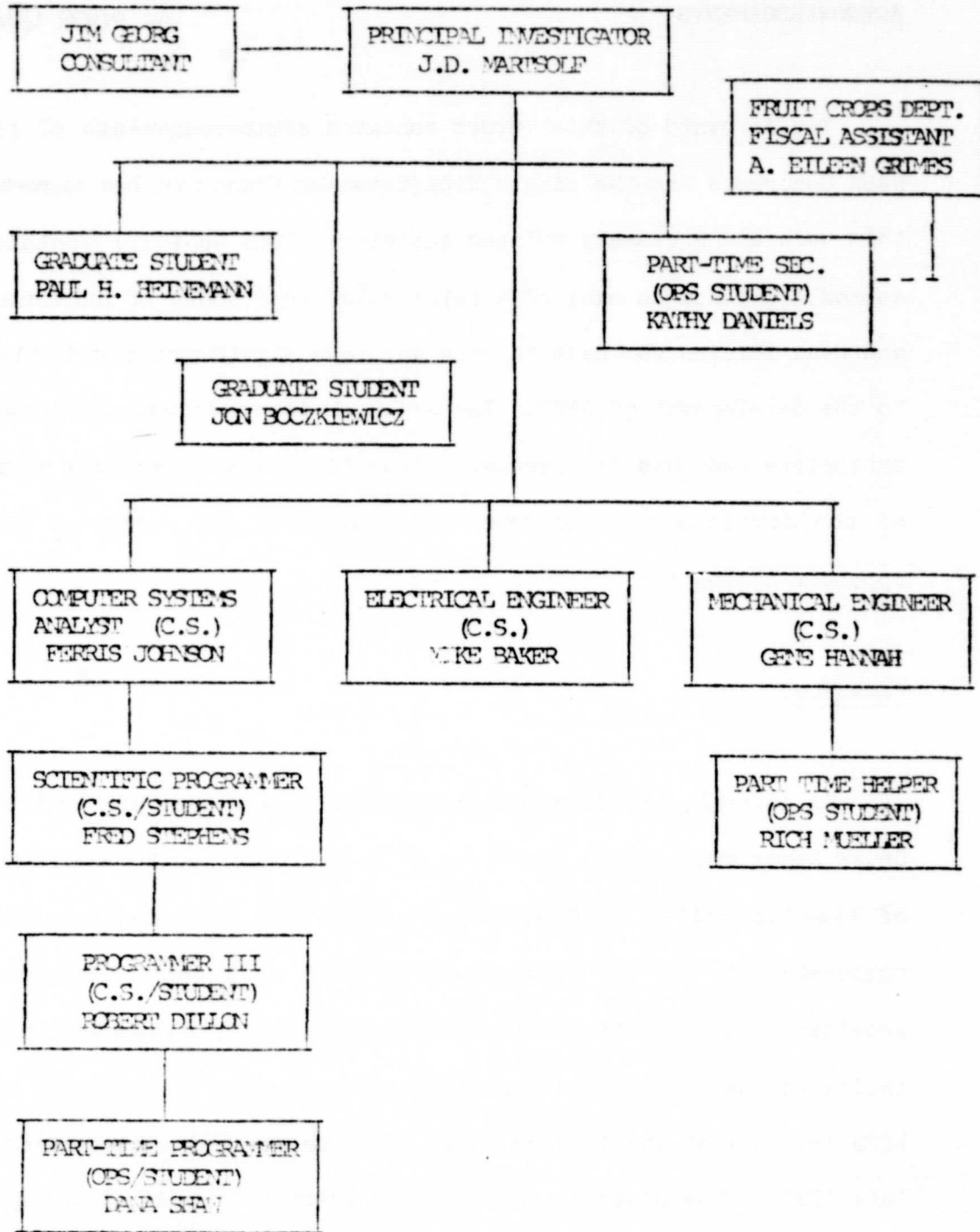

Figure 1. Organizational chart for Climatology Laboratory, Fruit Crops Department, effective for the winter and spring of 1982-83.

ORIGINAL PAGE IS  
OF POOR QUALITY

salaries by policy while the remaining members of the team may be and frequently are supported by grant funds or assistantships.

The following acknowledgements are included to provide some appreciation for personnel who do not show up on the organization chart along with some indication of their contributions (items 1 through 3). Items 3, 4, and 5 provide some addition insight into the type of contributions that members of the climatology team have made during the SFFS development and mentions, in some cases, team members who have moved on to other activities but deserve acknowledgement for their contributions while they served on the team. Finally, Item 6 points to some publications that have acknowledged such contributions.

1. Principal Investigator Changes: Seldom does a project survive one change in principal investigator; this development has sustained two. Dr. Jon F. Bartholic initiated the effort and remained in charge for approximately the first year (SFFS I in Table 1). Dr. John F. Gerber assumed the position in addition to job as Director of the IFAS Grants Office during and interim period (approximately SFFS II in Table 1) while Dr. J. David Martsolf was moving from The Pennsylvania State University to the University of Florida. Dr. Martsolf has directed the development since September 1979 which includes Phases III, IV,

V, and VI. Perhaps the major reason the project was not adversely affected by these changes is that Dr. Gerber had taken a keen interest in the effort since the beginning and Dr. Martsolf had served as a consultant to the project on several occasions prior to accepting the principal investigator's responsibilities.

-----  
Table 1. List of Six SFFS Development Stages with an indication of the period covered by each stage.  
-----

Stage	Period Covered	Contract No.
SFFS I:	Sept. '77 - June '78	NAS10-9168
SFFS II:	Sept. '78 - Sept. '79	NAS10-9168 A
SFFS III:	Oct. '79 - Jul. '80	NAS10-9168 A8,9
SFFS IV:	Aug. '80 - Jan. '81	NAS10-9892
SFFS V:	Feb. '81 - Nov. '81	NAS10-9892 A1
SFFS VI:	Dec. '81 - Mar. '83	NAS10-9892 A2,3

2. NASA Contract Monitor changes: Mr. C. Dale Pope handled these duties during the early stages of SFFS development under the supervision of Mr. U. Reed

ORIGINAL PAGE IS  
OF POOR QUALITY

ORIGINAL PAGE IS  
OF POOR QUALITY

Barnett. Mr. Frank W. Horn, Jr. served with Mr. Barnett during the early and mid periods of development to be replaced by Mr. Richard Withrow during the last two phases.

3. Personnel with unusually long tenures in SFFS development: Mr. James G. Georg has been a consultant with the project since its conception. Initially, he represented NOAA/NWS as the MIC of the Federal-State Frost Warning Service, Lakeland, FL, and UF/IFAS since his position had portfolio in both organizations. Upon retirement from NWS he accepted part-time responsibilities for SFFS development and has made contributions in general planning, user acceptance and model refinement. Mr. Ferris Johnson, Jr. and Mr. H. Eugene Hannah have been members of the development staff since before the project began and as such represent a major contribution by IFAS/Research since their salaries originate in that budget. Mr. Fredrick L. Crosby has cooperated with the development since the start from his position as Meteorologist in Charge of the NWS Forecast Office in Ruskin. Mr. Barnett's representation of NASA's interest has longevity nearly equal to these mentioned in this paragraph and Dr. John F. Gerber of IFAS has supported the effort since its beginning. One

of the main programmers with the effort, Mr. Fred Stephens has been with the team since 1978. The other main programmer, Mr. Robert Dillon joined the team full time in 1980.

4. Previous Post-Doctorate Support: Dr. Ellen Chen finished her doctorate program during the early portions of the development and continued to support the effort as a post-doctorate until January of 1981. Dr. Robert Sutherland remained on the staff until mid-1979 and became the chief author of the P-model in the process. Dr. Pierce Jones assumed Dr. Chen's responsibilities in 1981 and contributed a sensitivity analysis of P-model's predictions to various input parameters before returning to complete previous work later that year.

5. Previous programming and clerical support: It is quite typical of programs of this type to provide part-time employment to students studying computer science as programmers and to students who can benefit from experience in laboratory clerical duties. Mr. Bogdan Pelczynski, Mr. Steven E. Lasley and Mr. Gary del Valle were very productive programmers for relatively short periods during the SFFS development and the programs they developed have

served as good foundations for current software. Mr. Robert Lee preceeded Mr. Jon Boczkiewicz in programming the microcomputers and these efforts have greatly aided in the exposure of SFFS products beyond the NWS forecasters. Ms. Cynthia M. Weygant, Ms. Nancy Guzman, and Ms. Isabel Fernandez, the latter with draftsperson duties, have each contributed to the documentation of SFFS development through the numerous reports submitted to NASA and articles published in journals and magazines.

6. Additional documentation of acknowledgements: The following publications have published acknowledgements that supplement those provided by this appendix:

PUBLICATIONS THAT PROVIDE ACKNOWLEDGEMENTS

Martsolf, J. D. 1982. Satellite thermal maps provide detailed view and comparisons of freezes. Proc. Fla. State Hort. Soc. 95:(in press).

Martsolf, J. David. 1979. Frost protection: A Rapidly Changing Program. Proc. Fla. State Hort. Soc. 92:22-25.

Martsolf, J. David. 1980. An Improved Satellite Frost Warning System. Proc. Fla. State Hort. Soc. 93:41-44.

Martsolf, J. David. 1981. A Satellite Frost Forecasting System for Florida. In: Weiss, A. (Editor) Computer Techniques and Meteorological Data Applied to Problems of Agriculture and Forestry: a Workshop. NSF ATM-8020422 Proceedings, 143-164.

Martsolf, J. D. and J. F. Gerber. 1981. Florida Satellite Frost Forecast System Documents Freezes of January, 1981, and is Refined for Future Seasons. Proc. Fla. State Hort. Soc. 94:39-43.



Appendix C

SATELLITE WEATHER INFORMATION DISSEMINATION IN FLORIDA<sup>1</sup>

Florida decision makers benefit from space-age technology applied to a much older problem for those who capitalize on the Florida climate--the occasional frost or freeze. Color-coded thermal maps of the Florida peninsula were printed on the covers of the April issues (1981 & 1982) of the Florida Grower & Rancher (Vols. 74 & 75), as well as on the cover of the October, 1981 HortScience (Vol. 16:586) and in the Institute of Food and Agricultural Sciences (IFAS) Fruit Crops Fact Sheet 68. They document the freezes of January 13, 1981 and January 12, 1982 and serve as examples of products from the Satellite Frost Forecast System (SFFS).

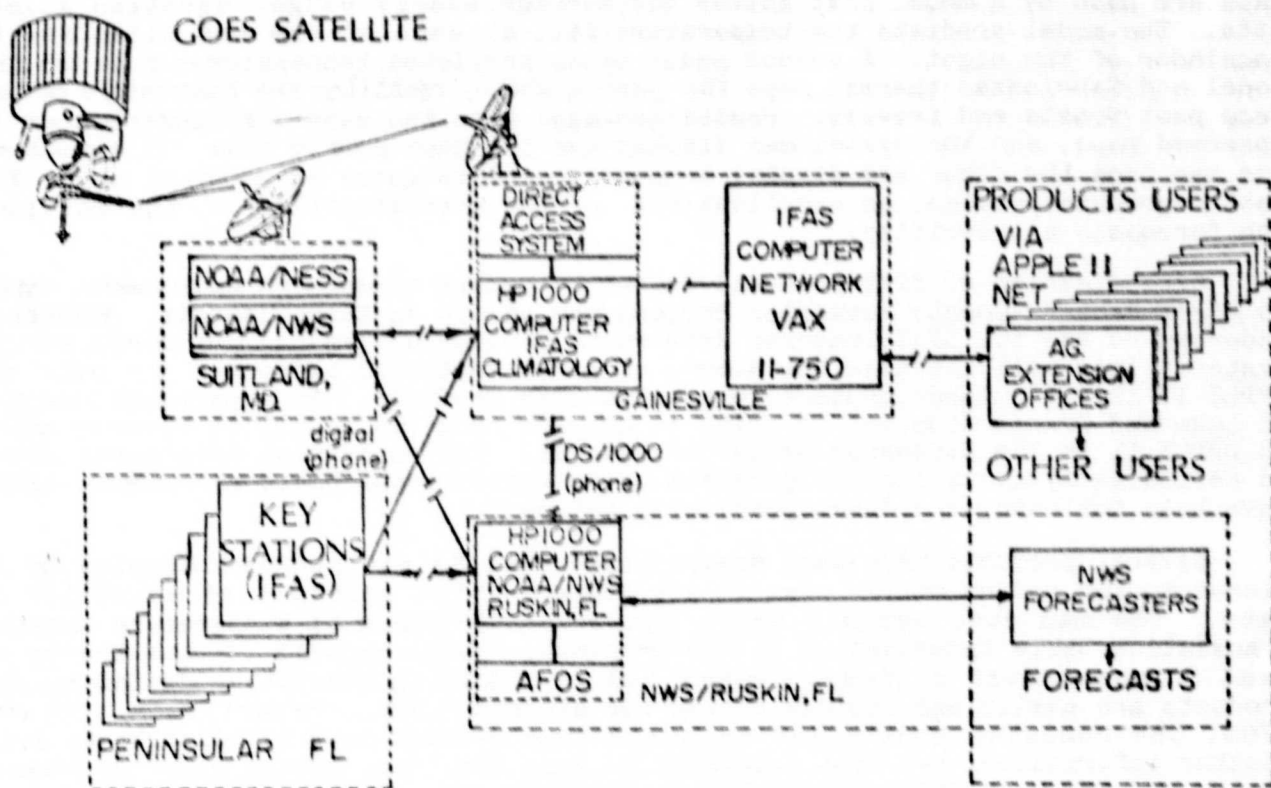

Satellite Freeze Forecast System as it appeared during the winter of 1982-83.

<sup>1</sup>Prepared for President's Advisory Council microcomputer demonstration, University of Florida, April 9, 1983 by J. David Martsolf, Professor of Climatology, and Paul H. Heinemann, Doctorate Candidate, Fruit Crops Dept., IFAS, Univ. of Fla., Gainesville, FL 32611.

SFFS has been developed by the Climatology Laboratory of the Fruit Crops Department of the Institute of Food and Agricultural Sciences (IFAS) of the University of Florida with support from the National Aeronautics and Space Administration (NASA). SFFS acquires satellite sensed temperatures from the eastern Geostationary Operational Environmental Satellite (GOES) operated by the National Earth Satellite Service, National Oceanic and Atmospheric Administration (NOAA) of the Department of Commerce. Instructions within a NASA-supplied minicomputer, the heart of SFFS, partition the temperature data into color bands and cause the resulting map to be displayed on a color TV screen within minutes of the reception of the satellite data.

SFFS not only acquires temperatures from GOES to display thermal maps in color but also schedules programs which predict future temperatures during the frost night. A sister minicomputer in Ruskin interrogates via telephone 10 automated weather stations (called key stations on the block diagram) over the peninsula of Florida to acquire air temperature, soil temperature, wind speed and net radiation. These data are used by a model that solves the surface energy budget equation at each site. The model predicts the temperature fall at each of the ten sites for the remainder of the night. A second model takes predicted temperatures from the first model and fabricates thermal maps for each night by recalling the temperature patterns from past frosts and freezes. Prediction maps have the same configuration as the observed maps, and the system can display the two maps side by side. It can subtract one map from the other and display temperature differences as a third map. This latter process provides an excellent test of the predictability of the models as the forecasts are verified.

Dissemination of SFFS products currently occurs through an experimental network to eight Florida County Extension Offices and one in southern Georgia. Efforts are underway to use the IFAS Computer Network to provide dissemination ports for the system. This will increase the number of ports that IFAS personnel may call with APPLE II and III microcomputers to acquire SFFS products. An experiment took place in Lake and Orange Counties in which 10 growers received satellite views by calling an APPLE II in the Extension Center in Tavares. One commercial television station is periodically acquiring the products on an experimental basis and several stations have been following the development with interest.

Several products have been disseminated that do not require display by the microcomputer and color TV. One is a black-and-white printout of satellite map data. The map uses symbols which can be equated back to temperature through a translation table incorporated in the printout. These records of the freeze are used in assessment of frost damage and in modifying harvesting decisions. Such products are easily and rapidly copied for distribution. Recently, a link with AFOS, the computer controlled communication network used by NOAA/NWS to handle weather information, has been developed to pass the frost warning bulletins developed by the NWS forecast office in Ruskin to the SFFS network (see diagram).

SFFS has served as a forerunner to Florida Agricultural Science and Technology (FAST), a not-for-profit corporation that proposes to disseminate products like those demonstrated by SFFS but covering the broad area of agricultural weather and climate information. SFFS is serving as an experimental tool in feasibility studies related to acquisition of radar and AFOS data, in anticipation of products that describe precipitation, evapotranspiration and severe weather patterns in much the same way SFFS displays frost hazards. Agriculturists in Florida should have opportunities to display highly tailored weather and climate products on color TV monitors driven by microcomputers interrogating data bases in the IFAS computer network and FAST. Such rapidly communicated products are likely to aid agriculturists, and resource managers in general, to more efficiently and effectively utilize the most valuable resource in Florida, its climate.

Appendix D

## FLORIDA FROST INFORMATION & DISSEMINATION SYSTEM<sup>1</sup>

J. David Martsolf  
University of Florida-IFAS  
Fruit Crops Department, Gainesville, FL 32611

### INTRODUCTION

The computer-controlled data acquisition, processing, and dissemination system that has recently been developed at the University of Florida is called the Satellite Frost Forecast System (SFFS). Most of the following discussion will concern SFFS but in light of a second generation system that is emerging from experiences with SFFS.

SFFS is a highly focused system. It has been created to fit a singular situation, frost. Color coded thermal maps are its primary products (see Fig. 1). Models provide forecasts of thermal maps that the satellite is expected to observe hours in the future.

Insights that have accrued through the experiments with SFFS provide a fertile environment in which to experiment with a larger system which has a much broader aim. Demands on SFFS for connecting ports provide convincing evidence that a larger system is required. A larger system is developing as the Florida Agricultural Science and Technology (FAST) system. In many ways SFFS is the model upon which FAST is developing. When FAST becomes operational, one of its initial tasks will be to assume the responsibilities that UF/IFAS has for SFFS operation, e.g. direct downlink of GOES and dissemination of products beyond the NWS forecasters. Consequently, it seems appropriate to discuss Florida's development of climate and weather information acquisition and dissemination in terms of what we have learned through SFFS, indicating how that experience will help build FAST.

### THE SATELLITE FROST FORECAST SYSTEM

The first of two minicomputers that are the main components of the Satellite Frost Forecast System (SFFS) was delivered in July of 1977. SFFS has evolved appreciably since then (Woods, 1977; Sutherland and Bartholic, 1977; Bartholic and Sutherland, 1978; Woods, 1979; Sutherland, et al., 1979; Martsolf, 1979, 1980abcd; Gaby, 1980; Sutherland, 1980; Barnett, et al., 1980; Martsolf, 1980abcd, 1981abc, Gerber, 1981; Martsolf, 1982). SFFS has developed with support from

---

<sup>1</sup>Florida Agricultural Experiment Station Journal Series No. 4638. NASA Contracts, NAS10-9168 & NAS10-9892, are acknowledged. Paper presented to NOAA Natl. Climate Program Office sponsored Workshop, Mar. 22-24, 1983, Tallahassee, FL.

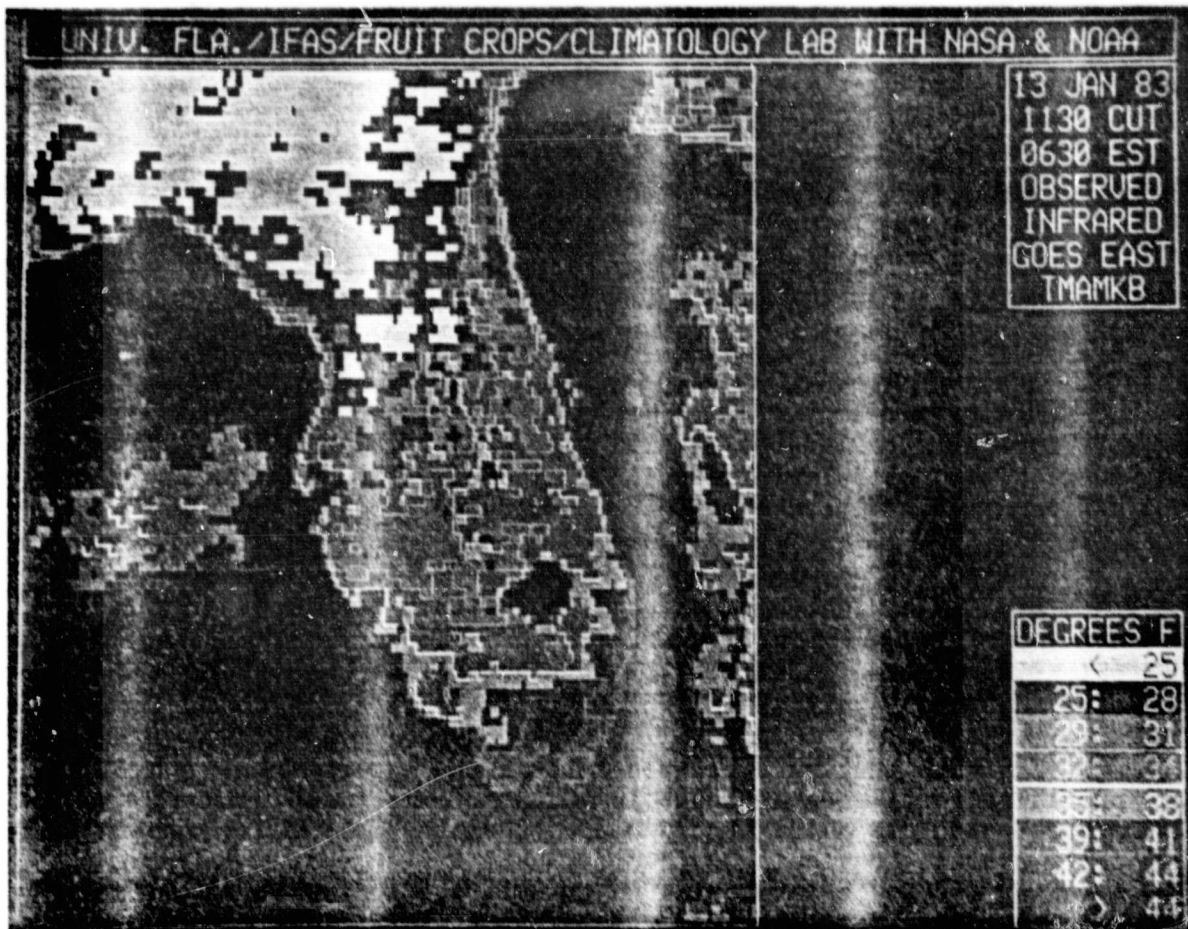

Fig. 1. Black and white rendition of the primary SFFS product. This is a photo of the television screen on which the color coded thermal maps are displayed for a typical but mild frost in 1983.

UF/IFAS and NASA (Contracts NAS10-9168 and NAS10-9892) and with the cooperation of NWS, over a period of almost 6 years. The last NASA contract for SFFS development has an end date of 31 March 1983. NOAA/NWS assumed responsibility for the SFFS operational computer system on December 1, 1982, and shares responsibility for the automated weather stations with UF/IFAS as of this March.

SFFS was originally conceived as not only a system with a very singular purpose but of stand-alone configuration (Fig. 2). The singular purpose broadened somewhat to include dissemination to growers through county extension agents as the hardware increased to include a development system and a direct downlink from the satellite. It simplifies the description to discuss SFFS as three systems:

1. the operational system
2. the developmental system
3. the integrated system

The operational system is located in Ruskin, Florida, where the Greater Tampa Bay NWS Forecast Office and radar are located. This is also the site of the Federal-State Frost Warning Service, a memorandum of understanding between NWS and UF/IFAS that has a history of more than 40 years of productive service to Florida agriculture and which has recently been updated to the Federal-State Agricultural Weather Service.

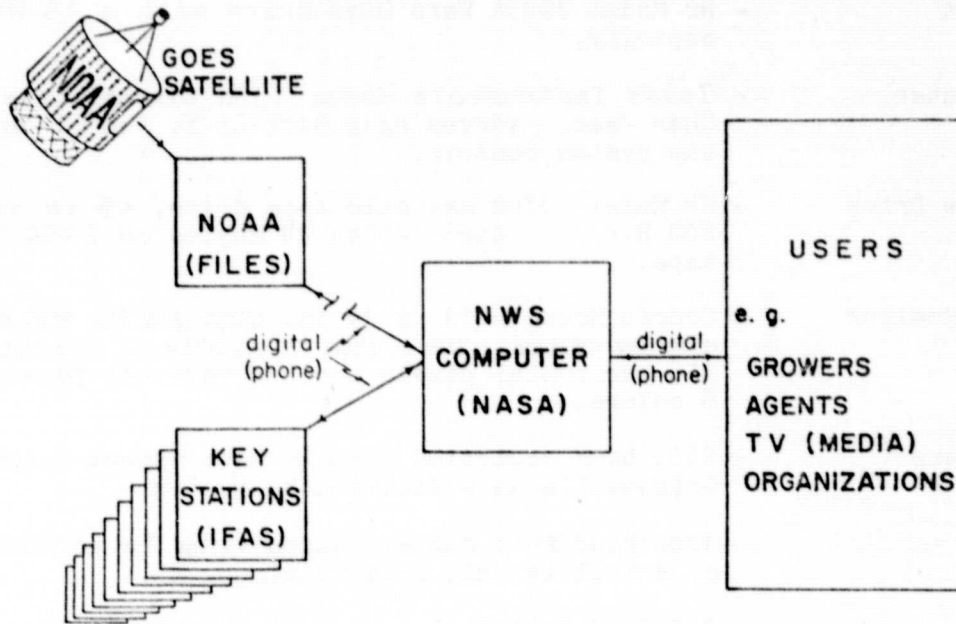

Fig. 2. Block diagram of SFSS as it was originally conceived and as the operational system had developed by the end of three years. SFSS acquired digital IR through NWS/Suitland, MD, once per hour, and surface observations from Key Stations by voice contact with volunteers by phone.

### SFSS OPERATIONAL SYSTEM

#### Description

The operational system can stand alone. (Figure 3) It is located in Ruskin, FL at the NWS Forecast Office. Table 1 lists the equipment that acquires the data, processes it into products and displays these products for the meteorologists to use in making their frost forecasts.

Table 1. Components list of the Operational System of SFFS, Ruskin, Fl.

Item	Brief Description
Mini-computer	- Hewlett-Packard Model 2112A (21MX-M) w/448 Kbytes of memory.
Terminal	- HP Model 2645A CRT type w/16 Kbytes of memory and 112 Kbytes of storage on two integrated magnetic tape cassette drives.
Disc	- HP Model 7905A Hard Disc drive with a 15 Mbyte capacity.
Printer	- Texas Instruments Model 733A thermal type, 30 Char./sec. serves as a back-up to the CRT and as the system console.
Tape Drive	- HP Model 7970B magnetic tape drive, 45 in/sec., 800 B.P.I., stores 20 to 24 Mbytes on 2400 inch tape.
TV Monitor	- Conrac Model 5211, a 19 in. high quality RGB color display system. The system is capable of displaying 256 horizontal pixels and 240 vertical pixels in 8 colors.
Modems	- 9600 baud dedicated line to development system in Gainesville as a distributed system. - 1200 Baud full duplex, autodialing for acquisition of satellite data from Suitland, MD. - 300 Baud full duplex, autodialing for calling 10 automatic weather stations.
AFOS Link	- listen only link to the Automated Field Operations System Data General computer through which weather data and forecasts are acquired.

Data acquisition

Satellite data.

SFFS acquires data from two sources: 1) GOES-EAST and 2) 10 automated weather stations scattered over Peninsular Florida. The acquisition of satellite data from GOES-East may occur by either of two routes: 1) to Suitland, MD, by 1200 baud land line or 2) by 9600 baud dedicated line to the development system in Gainesville, Florida. The Suitland source provides a Florida sector of the infrared data once per hour. However, the source is experimental in an operational environment. The batch program that fills the Florida queue (a series of files available to SFFS by phone) runs on a lower priority than



most of the operational tasks with the result that the queue is filled on the average of 66% of the time and when it is filled the data averages several hours delay. The Gainesville source has been available since February 22, 1982. Since that date its reliability has been nearly perfect and the delay but a few minutes. The data is available every half hour and the sector may be easily changed.

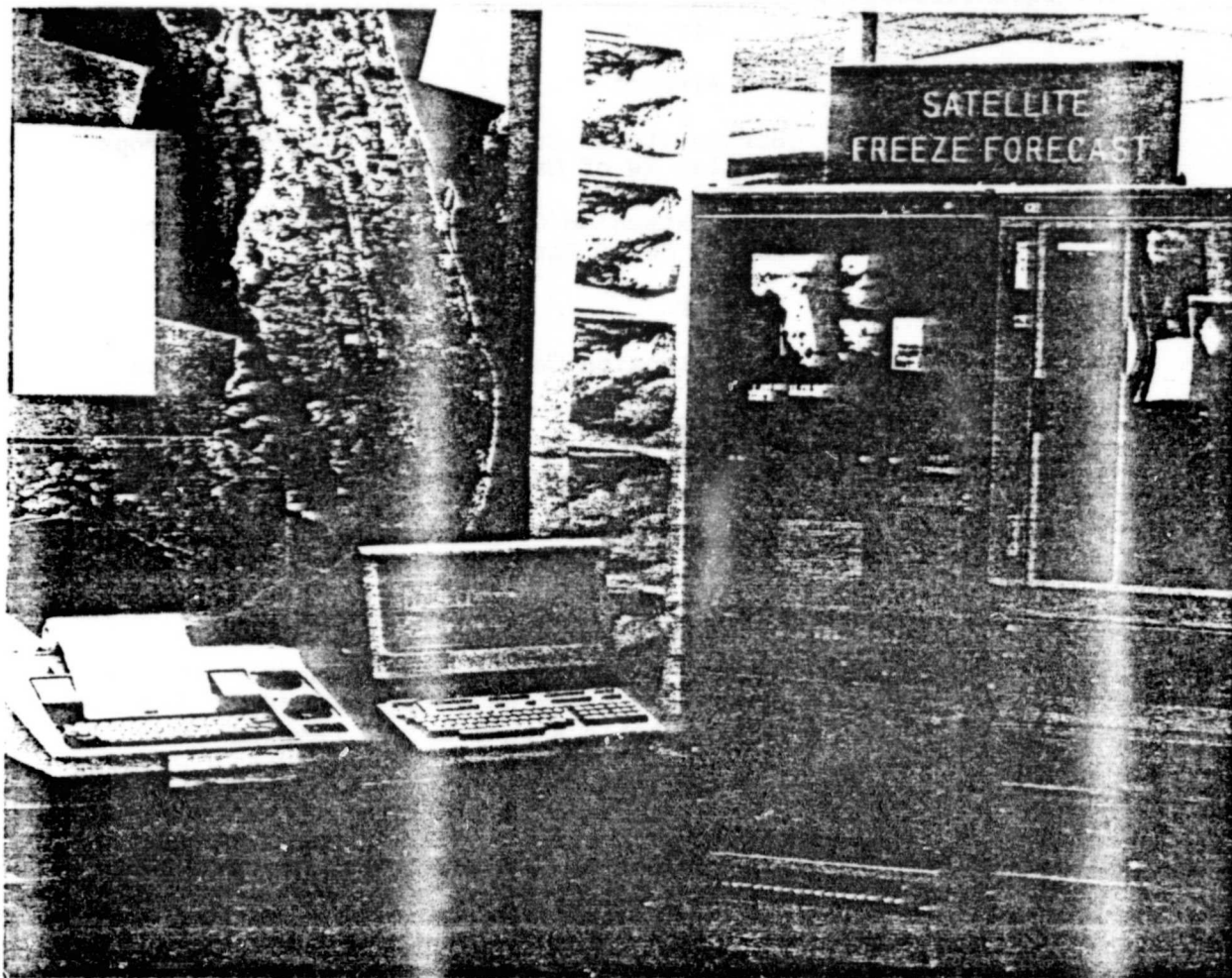

Fig. 3. SFFS Operational System located in National Weather Service Forecast Office in Ruskin, FL. A TI printer/terminal and an HP CRT terminal are visible on left. The Conrac color monitor, HP 21MX M, extender and Vadic modem chassis occupy the left hand rack from top to bottom while a mag tape and 15 megabit disc occupy right hand rack.

#### Surface data.

SFFS acquires surface observations from 10 automated weather stations. Their locations are given in Table 2.

The automated weather station (AWS) is diagrammed in Figure 4. The components of the AWS are listed in Table 3. Normally, the AWS's are interrogated once per hour on frost nights beginning near

ORIGINAL PAGE IS  
OF POOR QUALITY

Table 2. List of key stations serving SFFS, indicating their location and affiliation.

No.	Station	Location	Affiliation
1	Tallahassee	Airport	NWS
2	Jacksonville	Airport	NWS
3	Gainesville	Horticultural Unit 5 miles NW of Gainesville	IFAS/Fruit Crops
4	Tavares	Agr. Extension Center Rural, SW of Tavares	IFAS/Extension
5	Ruskin	Site of	NWS
6	Bartow	Ag. Extension Center	IFAS/Extension
7	West Palm Beach	Airport	NWS
8	Belleglade	Branch Experiment Station	IFAS/AEC
9	Immokalee	Branch Experiment Station	IFAS/AEC
10	Homestead	Branch Experiment Station	IFAS/AEC

sunset. The success rate is about 95% in acquiring data from these stations largely because the software has been refined to include numerous attempts for those stations that do not respond initially or send in data that is suspect. The extent to which the calling software will press the equipment to be successful in this acquisition process is controlled by the SFFS scheduling routines. Trial and error have been effective teachers. Refinements in the software have been checked against previous renditions to test improvement.

Initially these ground stations were manned by volunteers. There were a dozen key stations selected to represent peninsular Florida in locations in which volunteers read and reported the sensings. In the third frost season the 10 remaining stations were automated by the addition of microprocessors manufactured by Darcom.

Data Processing

Color coded thermal maps.

SFFS acquires data to process into products tailored to the needs of the user. The primary products of SFFS are a series of color-coded maps, often termed thermal maps, displayed on the Conrac color monitors located in Gainesville (the development system) and in Ruskin (the operational system). These products fall into two categories: observed maps and predicted maps. A scheduling program provides the operator with an opportunity to exercise options by

ORIGINAL PAGE IS  
OF POOR QUALITY

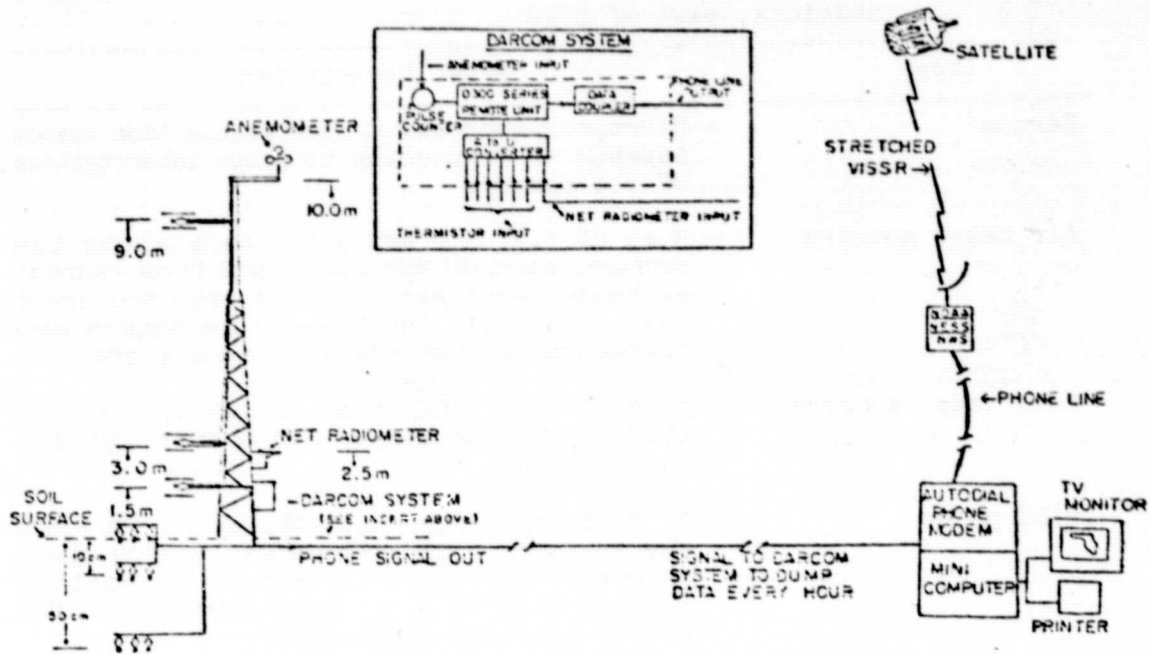

Fig. 4. Diagram of the automatic weather station and its relationship to the SFFS operational system.

modifying instructions when initiating SFFS operation. Once started (scheduled) SFFS operates on previous instructions, unless there are changes. Normally, one observed map and three predicted maps are displayed as the generating programs complete their construction during each hour of the system's operation. The scheduling program looks in an answer file for its instructions concerning the options. For example, the rather broad range of temperatures from 13 degrees  $F$  to 50 degrees  $F$  is often chosen for the initial thermal map display to assure complete coverage of the data. The operator then has the opportunity to request the system to refine the temperature resolution of the display by requesting a narrower temperature range.

In addition to flexibility in the temperature range per color, the operator has options in the type of presentation, split screen permitting comparison of two thermal maps side by side, or the enlargement of a particular portion of the screen. With a little practice the user can slice the temperature range into appropriate increments that reveal isotherms near critical values for the forecast or for plant damage.

Black and white symbols maps.

The big freeze of January 13-14, 1981, revealed that secondary products from the system were also in demand. Figure 5 is a copy

Table 3. List of Components of each of 10 automated weather stations, part of SFFS

Item	Brief Description
Darcom	- Microprocessor based data acquisition system capable of responding to phone interrogation of its memory.
Air temp. sensors	- 3 ea at 1.5, 3.0 and 9.0 meters above the surface, shielded top and bottom from radiant exchange, aspirated by wind, for nocturnal use. Initially, the temperature sensors were thermocouples but now are thermistors.
Soil temp. sensors	- 3 ea at 0, 10 and 50 cm in depth; 3 series thermistors per sensor for better spatial integration.
Wind speed	- R. M. Young 3-cup light-chopper at 10m above the surface. A GE silicon/Darlington photo detector (type L-14-F1) and an IR emitter (Type LED-55B) have been substituted for better counting reliability.

of a printout of the so-called "symbols map." A translation table has been added that permits the user to translate the symbols in a particular area into temperatures. The map can be easily reproduced in quantity and many of these have been used by decision makers in the areas of crop transportation, processing, futures, etc. A detail that becomes apparent in viewing this map is that differentiation of temperatures ceases below 13.7 degrees F. This is an arbitrary limitation that results from the necessity of assigning a symbol set to temperature values in order to easily move them through the NOAA/NWS program and into the SFFS queue in Suitland. The raw data covers a much broader temperature range, i.e. -110 degees C to 568 degrees C. covered by 256 counts.

Automated weather station temperatures.

A secondary product of the system is the printout of the 1.5m air temperatures from the automated weather stations. These data are available faster than those from minimum-temperature thermograph networks. The product is easily reproduced and inexpensively duplicated for mass dissemination.

Predicted thermal maps.

Two models operate in series to produce the predicted products. The first, known as P-model, is an energy budget model requiring as inputs data from the key stations and estimated or observed dew points from the SFFS operator. The P-model has been published

(Sutherland, 1980) and discussed in the literature (Shaw, 1981; Sutherland, 1981). The "P" in P-model stands for predictive as well as physical. The model outputs 1.5m air-temperature forecasts for the remainder of the night, i.e. up to 7AM the following morning. These forecasts are printed out in tabular form along with the previously observed 1.5m air temperatures at the key station for the operators to view at the system printer. The forecasters use these as part of the input information they have available to make their frost warnings for various areas of the state.

The second model, called the S-model, requires the output of the P-model and the satellite data to produce forecasted satellite maps. The "S" stands for space, statistical and satellite. It must build a predicted satellite view, a thermal map, from the predicted temperature at 10 locations, into temperatures for each of the 8 km by 8 km pixels within the borders of the peninsula. A matrix of coefficients relates the predicted key station temperatures to pixels surrounding the key station. These coefficients primarily describe the distance between the key station and the pixel to be predicted but they are one of the ways that recall of the distribution of temperatures in past freezes can be available to the prediction process.

#### SFFS Development System

Early in the development of SFFS, IFAS procured a sister minicomputer system. This avoided the problems of moving the SFFS operational system back and forth between Ruskin and Gainesville and provided a back-up to the Ruskin system during the frost season. The development system has been kept as compatible as possible with the operational system so that software developed for one runs on the other. Table 4 lists the components of the development system.

#### Data Acquisition

The development system has the capability of acquiring the same data as the operational system but with some minor considerations.

1. The development system has a more difficult time acquiring AWS data because a recent change in telephone policy on the campus forced it into use of SunCom lines which are notoriously more noisy than regular voice grade lines.

2. The operational system acquires the AFOS data initially and only portions of it are linked through the distributed system 9600 Baud line to the development system.

3. The development system downlinks the satellite directly and has the capability of viewing much more of the hemisphere of data than can be shared with the operational system. However, the 9600 Baud line follows.

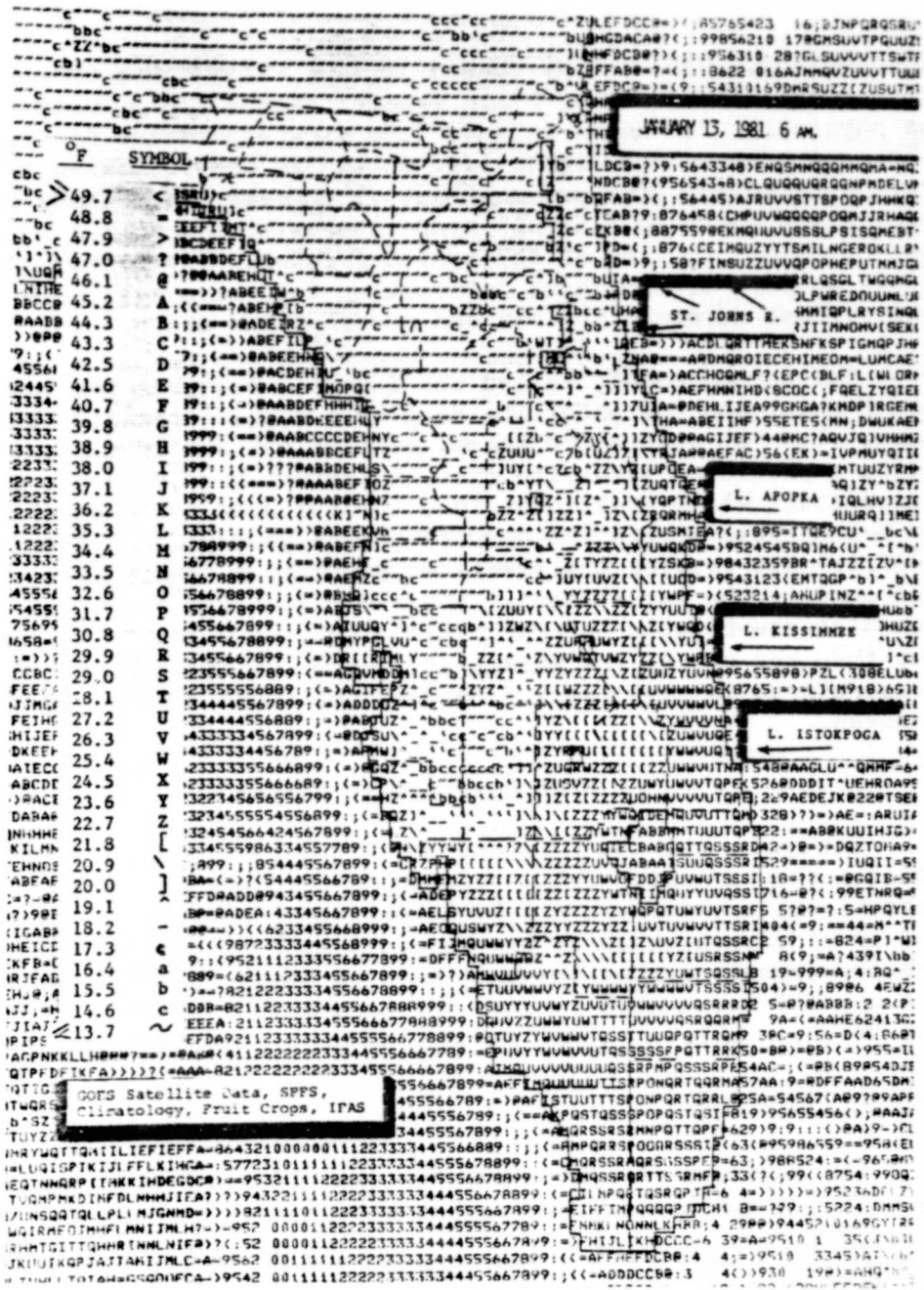

Fig. 5. January 13-14, 1981 Freeze, as diagrammed with a "Symbols" map. A translation table is superimposed.

The antenna system became operational February 22, 1982. Since then Software has been developed to take advantage of the data being available on half-hour intervals versus hourly, of twice as many pixels of IR data, and of numerous sectors scattered over the hemispheric view of GOES-East. Before GOES-WEST failed the antenna was occasionally turned to receive Goes-West data from it. A second bit sync was added to the system to permit uisition. The data arrives from the antenna in binary whereas these data are encoded

Table 4. Components of the SFFS Development System, University of Florida, Gainesville, Florida.

Item	Brief Description
Mini-computer	- Hewlett-Packard Model 2113A (21MX-E) with 768 Kbytes of memory
Terminals	- 2 ea. HP Model 2645A w/16 Kbytes of self-contained memory. One terminal has a pair of integrated cassette magnetic tape drives, each with a capacity of 112 Kbytes of storage. - 3 ea HP Model 2621 w/4 Kbytes of memory. One of these contains an integral thermal printer.
System console	- Texas Instruments Model 733A thermal paper type printer.
Discs	- 3 ea. HP Model 7900A discs with 5 Mbyte per disc (2.5 Mbyte of which is removable). - 1 ea HP Model 7912P Winchester type disc with 67.5 Mbyte capacity.
Tape drive	- HP Model 7970B, 800 BPI, 20 to 24 Mbytes per 2400' reel.
Printer	- HP Model 2635A medium duty impact matrix with approx. 180 characters per second speed. A keyboard permits use as a back-up terminal.
Television display	- Conrac Model RHM-19, 19 in. TV monitor from NASA, RGB, capable of displaying 786 horizontal pixels and 480 vertical pixels in 8 colors. An additional white over-layer channel is non-destructive to under-lain colors. This display system is an Intermedia model 4601. Additionally a Hewlett-Packard model 91200B system drives a Panasonic model CT-1910M monitor displaying 256 horizontal pixels and 240 vertical pixels. The HP system emulates the Ruskin display system.
Plotter	- HP Model 7210 single-pen with a resolution of 100 points per in.
Modems	- 1 ea. 9600 Baud dedicated line modem serving the other half of the distributed system link with the Ruskin machine, Paradyne model M96. - 1 ea. 300 Baud full duplex autodial modems integrated in a Vadic chassis. - 2 ea. 300 Baud full duplex answer-only modem in same chassis. - 1 ea. 1200 Baud full duplex autodial modem in same chassis. - 1 ea. 300/1200 Baud full duplex answer-only auto speed detection modem in same chassis.
Antenna interface	- HP 12566 data interface card and lab developed and installed hand-shaking signal producing circuits.

in the ASCII character set when communicated from Suitland. Having a 92 step range in the latter case versus a 256 step range in the original binary data causes truncation at some point. Thus the antenna cures a problem that has appeared in the cases of both the major freezes of '81 and '82 when temperatures fell below the lowest temperature encoded in the Suitland data, i.e. about 13 degrees F.

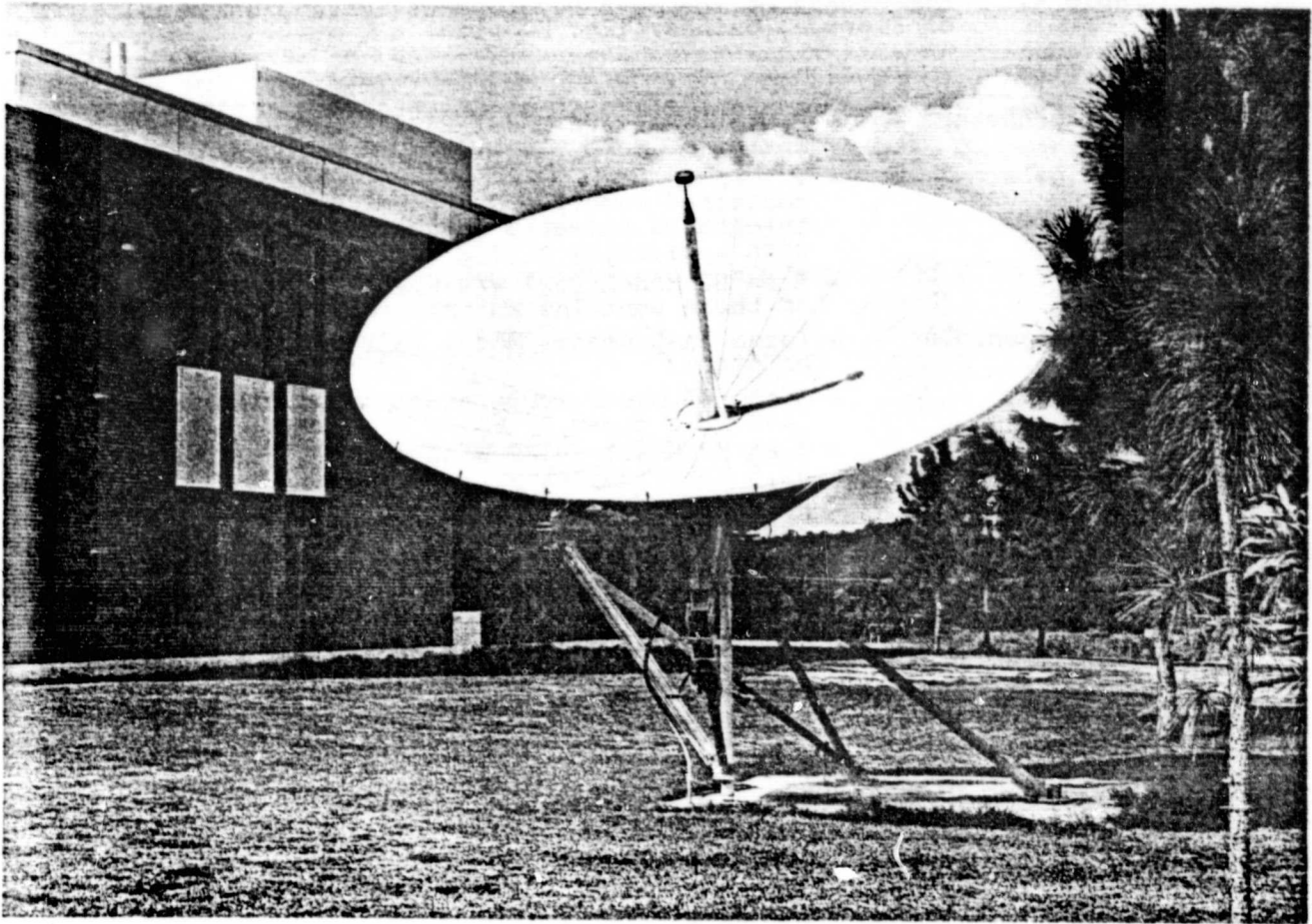

Fig. 6. SFFS direct downlink from GOES located just East of HS/PP Bldg. on the UF Campus in Gainesville, Florida.

#### Product Dissemination

The primary user of SFFS output is the forecaster. The NOAA/NWS forecaster incorporates SFFS information into the frost warnings and communicates these to users through the normal communication channels that have developed over years of NWS service to its clientel.

Additional users of SFFS information include all other consumers showing interest in receiving the information. During the 80-81 frost season, two county extension offices (one in Polk County and the other in Lake County) received the thermal maps by an APPLE II computer link with the Gainesville minicomputer. During the 81-82 frost season the number of agents linking to the system through the experimental APPLE network increased to ten. In the 82-83 season the IFAS Computer Network became the source of SFFS products for IFAS users, i.e. the county agents. The SFFS development system



Table 5. List of components of the Direct Downlink Antenna System, a part of the SFFS Development System in Gainesville, Florida.

Item	Brief Description
Antenna	- Scientific Atlanta 5 meter dish Model 3556-5 with AZ-EL adjustable mount assembly.
Feedhorn	- Band pass filter, isolator, low noise amplifier, dipole receptor, and 1/4 wave cavity.
Cable	- I.F. bandpass line amp, filter assembly, and power supply.
Down converter	- Oscillator, phase lock multiplier, filters, mixer, post amp, cable drivers, and power supply.
Demodulator	PSK Model 728.
Bit Stream Sync	- EMR Model 720 PCM & DECOM Systems Inc. Model 7136 PCM.
Sectorizer	- EMR Model 822 Frame synchronizer and Sectorizer, GOES PCM Simulator and bit error detector.

automatically loads the queues in the IFAS Computer System. APPLE III's, IBM PC's and Zenith Z-100's now have software that permits them to interrogate either the development system or the IFAS Computer System VAX for SFFS products but these programs do not have the automatic acquisition mode that characterizes the APPLE II software (see fig. 7). Growers, media, processors, etc. are expected to arrange to connect with the county computers or terminals to view thermal maps, as well as to obtain other system products through the cooperative extension service. Table 6 lists the agricultural extension agents that are members of the experimental APPLE network.

The integrated system is the sum of the two SFFS systems (the operational system in Ruskin with its associated automated weather stations and the development system in Gainesville with its downlink antenna system), the IFAS Computer System as a disseminator, and FAST. Figure 8 diagrams the integrated system with the exception of FAST which will initially interface through the development system and later with the IFAS Computer System.

#### FAST and the Future

FAST became tangible as a not-for-profit corporation with a non-faculty (UF) board of directors in January of this year. Dr. John F. Gerber is on temporary leave from his UF/IFAS duties to serve as the executive director of FAST. The author of this paper is the principal investigator of a contact between IFAS and FAST to



Fig. 7. Apple II Plus used as a SFFS terminal. Two disc drives, a clock, a software controlled modem, and a color monitor are needed for a complete system capable of automatic data acquisition, display and archival.

transfer technology to FAST accrued through SFFS development by the Climatoloy Laboratory of the Fruit Crops Department and to develop additional products from radar and AFOS sources.

FAST is leasing a Cyber 730 and space in a building in the new research park in Alachua, Fla., from the University of Florida Foundation (SHARE). It will supply products similar to those developed for SFFS but covering a broader spectrum of weather and climate information needs. FAST is expected to gradually assume much of the operational responsibility that the SFFS development system has accumulated and in the process acquire support for its services from members it serves. FAST is likely to develop color renditions of the following:

- thermal maps of GOES IR
- reflectance maps of GOES VIS
- summary maps of weather radar data
- composites of GOES and radar data
- lightning maps
- plotted severe weather advisories and other NWS forecasts.

Table 6. APPLE Network Listing, effective February of 1983, in approximately the order in which each joined the network.

County	City	Agent	Crop(s) Covered
Lake (& Orange)	Tavares	John Jackson (Francis Ferguson)	Citrus, ornamentals
Polk	Bartow	Tom Oswalt	Citrus
Bade	Homestead	Seymour Goldweber	Subtropicals, vegetables
St. Lucie	Ft. Pierce	Pete Spyke	Citrus, Ornamentals
Madison	Madison	Jacque Breman	Peaches
Brooks	Quitman, GA	Henry Carr	Peaches
Palm Beach	Palm Beach	Clayton Hutcheson	Citrus, vegetables, ornamentals
Collier	Naples	Reggie Brown	Citrus, IPM
Highlands	Sebring	Tim Hurner	Citrus
Manatee	Bradenton	Marlowe Iverson	Citrus, ornamentals
Indian River	Ft. Pierce	Brian Combs	Citrus
Lee	Punta Gorda	Susan Hedge	Citrus, ornamentals

Two Control Data Corporation software packages are expected to aid the development of these products, i.e. CDC/McIDAS and INTERSYS.

The characteristics of the system are primarily apparent to the end user as they are displayed on his system terminal. The new Zenith Z-100 dual-processor microcomputer is being programmed by members of the SFFS development team toward testing its ability to serve as one of many microcomputer systems with which the FAST system expects to be compatible. Sufficient development has occurred in this software that this microcomputer along with the more typical SFFS APPLE II Plus is demonstrated during the workshop in which this paper is presented.

One of the concepts that developed from experiences with SFFS operation which is expected to benefit the FAST system is the need to serve members as uniquely as possible with products tailored to their specific needs. The on-line storage capability of the Cyber 730 is expected to facilitate the handling of numerous unique account. Efforts will be made to accumulate and store information in the member's requests uniquely when their particular site, or the manner in which they have indicated they intend to use the information, warrants special processing of of their products.

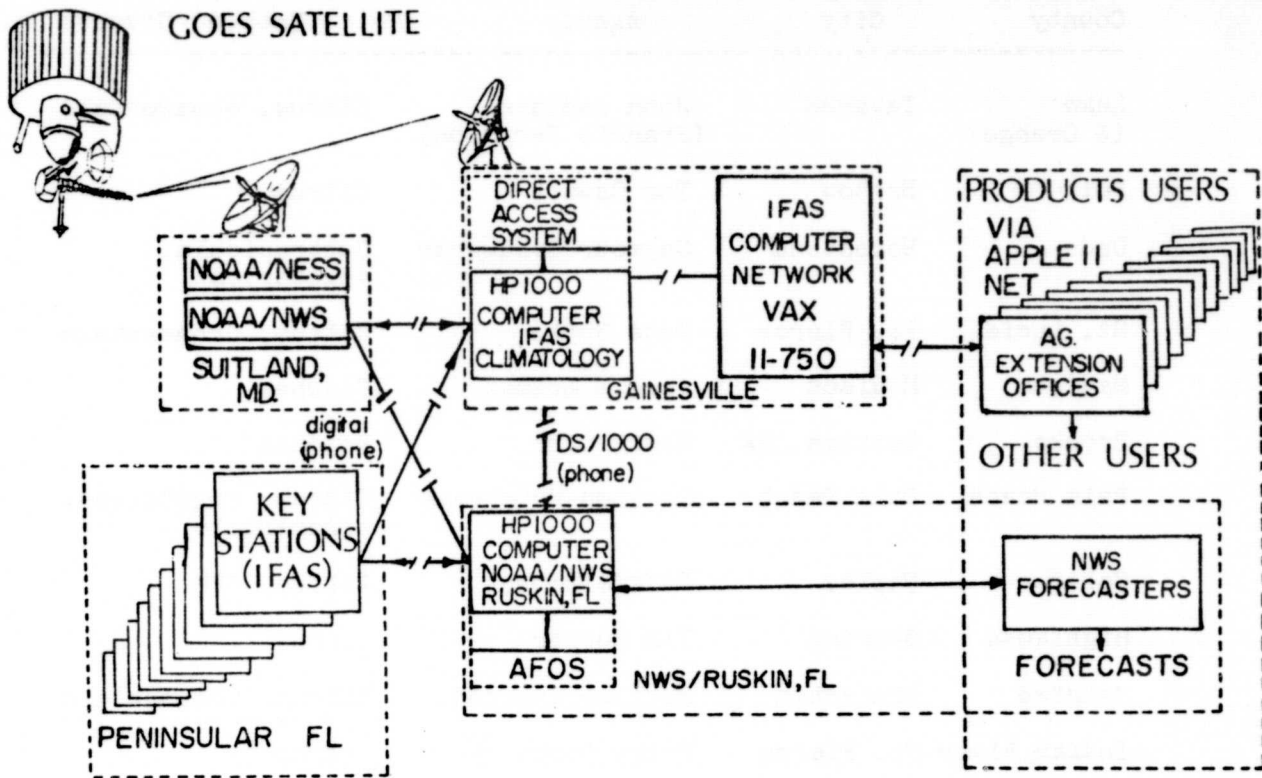

Fig. 8. Block diagram of the components of the Integrated SFFS System with the exception of the newest component FAST which may be placed above the the SFFS Antenna System (Direct Access System) and be interfaced initially with that antenna and to the development system (i.e. Climatology).

ACKNOWLEDGEMENTS

Both IFAS/UF and NASA (Contracts NAS10-9168 and NAS10-9892) have funded SFFS development with NOAA/NWS cooperating. USDA/Extension has funded product dissemination to county extension offices through Grant 12-05-300-535. Prior to this grant for the dissemination effort, Dean John f. Woeste, who participated in this workshop, should be acknowledged for his special interest in and support of the extension component of the effort. Dr. Jon F. Bartholic served as the principal investigator (PI) during the first 1.5 of the effort years before becoming an Assistant Director at Michigan State

University, Agricultural Experiment Station. Dr. John F. Gerber is acknowledged for his service as interim PI for a period of approximately one year, in addition to service as IFAS Grants Office Director. Dr. Michael J. Burke, Chairman of Fruit Crops, Dr. Robert Sutherland, and Dr. Ellen Chen, both previously Post Doctorate Assistants on the SFFS project, and Mr. James G. Georg, Consultant Meteorologist, have made special contributions to SFFS development. Dr. James M. Dodge, NASA/HQ, Mr. U. Reed Barnett, Jr., and Mr. Richard A. Withrow, both of NASA/KSC, have coordinated NASA's support to the development. Mr. Frederick C. Crosby of NOAA/NWS has coordinated NOAA's cooperation and provided operational testing of SFFS at the Ruskin WFO. Mr. Ferris G. Johnson, Jr. has coordinated the software development with recent programming support from Mr. Fred D. Stephens, Mr. Robert A. Dillon and Mr. G. Dana Shaw. Mr. Eugene H. Hannah and Mr. Michael P. Baker have developed the key station instrumentation and the latter has responsibility for the antenna system. Mr. Jon Boczkiewicz, a microcomputer specialist, and Mr. Paul H. Heinemann, a doctorate student, have aided dissemination, data acquisition, and modeling development. Mr. Richard E. Mueller has helped Mr. Hannah on a part time basis. Mrs. Alice E. Grimes continues her support in bookkeeping and procurement. Miss Kathleen M. Daniels, a part-time secretary, is responsible for the text processing that permitted the development system to output this report on one of its printers.

#### References

- Anonymous. 1981. Florida Grower and Rancher 94(4):Cover.
- Anonymous. 1982. Florida Grower and Rancher 95(4):Cover.
- Barnett, U. R. and J. D. Martsof. 1981. Satellite Freeze Forecast System. NASA/KSC Annual Report on Research and Technology, pages 12-13.
- Barnett, U. Reed, J. David Martsof, and Frederick L. Crosby. 1980. Freeze line system. Proc. 17th Space Congress, Cocoa Beach, Fl., 4:9-20.
- Bartholic, Jon F. 1978. Crop freeze protection - The energy crisis plus four years. The Citrus Industry, 59(10):22-28.
- Bartholic, J. F. and R. A. Sutherland. 1978. Future Freeze Forecasting. Proc. Fla. State Hort. Soc. 91:334-336. Brandli, Henry W. 1981. Weather satellites and Agriculture, Florida Grower and Rancher, 74(4):4,8,9,34.
- Chen, Ellen, L.H. Allen, Jr., J.F. Bartholic, R.G. Bill, Jr., and R.A. Sutherland. 1979. Satellite-sensed winter nocturnal temperature patterns for everglades agricultural area. J. Appl. Meteor. 18(8):992-1002.
- Chen E., Allen L.H., and J. F. Gerber. 1982. Delineation of cold-prone areas using Nighttime SMS/GOES Thermal Data: Effects of Soils and Water. J. Appl. Meteor. 21(10):1528-1537.

- Chen, E., and J. D. Martsolf. 1981. The development of nocturnal GOES infrared data as a source of climate information. Final Report, National Climate Program Office, NOAA, Contract NA80AA-D-00129, 174pp.
- Gaby, Donald C. 1980. Comments on "A real-time satellite data acquisition, analysis and display system - A practical application of the GOES network". J. Appl. Meteor. 19:340-341.
- Martsolf, J. D. and J. F. Gerber. 1981. Florida Satellite Frost Forecast System Documents Freezes of January, 1981, and is Refined for Future Seasons. Proc. Fla. State Hort. Soc. 94:39-43.
- Martsolf, J. David. 1980a. An improved satellite frost warning system. Proc. Fla. State Hort. Soc. 93:41-44
- Martsolf, J. David. 1980b. Evolution in frost protection. Amer. Fruit Growers 100(2):12,92-94.
- Martsolf, J. David. 1980c. Frost protection. The Citrus Industry Magazine 61(9):17-26.
- Martsolf, J. David. 1980d. Freeze line system. Proc. Workshop on Crop Management Modeling Utilizing Environmental Data. VPI & SU, NASA, and USDA/ARS sponsors. Jan. 17-18, pages 49-57.
- Martsolf, J. David. 1979. Frost protection: A Rapidly Changing Program. Proc. Fla. State Hort. Soc. 92:22-25.
- Martsolf, J. David. 1981a. Satellite frost forecast system, HortScience 16(5):cover, 586.
- Martsolf, J. David. 1981b. Satellite View of the January 13, 1981, Freeze. Fla. Coop. Ext. Serv. Fruit Crops Fact Sheet 68, 4 pages.
- Martsolf, J. David. 1981c. A Satellite Frost Forecasting System for Florida In: Weiss, A. (editor) Computer Techniques and Meteorological Data Applied to Problems of Agriculture and Forestry: a Workshop. NSF ATM-8020422 Proceedings, 143-164.
- Martsolf, J. David. 1982. Satellite thermal maps provide detailed view and comparisons of freezes. Proc. Fla. State Hort. Soc. 95 (In press).
- Oswalt, T. W. 1981. Comparison of Satellite Freeze Forecast System Thermal Maps with Conventionally Observed Temperatures. Proc. Fla. State Hort. Soc. 94:43-45.
- Schnapf, A. 1980. 20 years of weather satellites- where we have been and where we are going. Proc. 17th Space Congress, NASA/KSC, Apr. 30-May 2, Cocoa Beach, Fl., pages 2-1, 2-20.
- Shaw, Roger H. 1981. Comments on "A short-range objective nocturnal temperature forecasting model." J. Appl. Meteor. 20:95.
- Sutherland, Robert A., and Jon F. Bartholic. 1977. A freeze forecasting model based upon meteorological satellite data. Proc. International Soc. Citriculture 181-183.

- Sutherland, Robert., Jane L. Langford, Jon F. Bartholic, and Robert G. Bill, Jr. 1979. A real time satellite data acquisition, analysis and display system - A practical application of the GOES network. J. Appl. Meteor. 18(3):335-360.
- Sutherland, Robert A. 1980. A short range objective nocturnal temperature forecasting model. J. Appl. Meteor. 19:247-265.
- Sutherland, Robert A. 1981. Reply. J. Appl. Meteor. 20:96-97.
- Waters, Marshall P., and Robert N. Green. 1979. A merged satellite infrared and manually digitized radar product. Machine processing and Remotely Sensed Data Symposium Proceedings, pages 183-191.
- Woods, Chuck. 1977. Satellite freeze prediction system for Florida. Citrus and Vegetable Magazine 40(1): 6,24.
- Woods, Chuck. 1979. Satellite paints Florida weather portrait. Sunshine State Agricultural Research Report 23(1)4,5,22.