

NASA Technical Memorandum 83440

NASA-TM-83440 19830024672

# Tribological Measurements on a Charnley-type Artificial Hip Joint

William R. Jones, Jr.  
*Lewis Research Center  
Cleveland, Ohio*

July 1983

LIBRARY COPY

SEP 13 1983

LANGLEY RESEARCH CENTER  
LIBRARY, NASA  
HAMPTON, VIRGINIA

**NASA**

39

1

1

RN/NASA-TM-83440

DISPLAY 39/2/1

83N32943\*\*

ISSUE 21

PAGE 3444

CATEGORY 27

RPT#: NASA-TM-83440

E-T50T NAS 1.15:83440

83/07/00

30 PAGES

UNCLASSIFIED DOCUMENT

UTTL: Tribological measurements on a Charnley-type artificial hip joint

AUTH: A/JONES, W. R., JR.

CORP: National Aeronautics and Space Administration, Lewis Research Center,  
Cleveland, Ohio. AVAIL.NTIS SAP: HC A03/MF A01

MAJS: /\*FRICTION/\*JOINTS (ANATOMY)/\*PROSTHETIC DEVICES/\*TRIBOLOGY/\*WEAR

MINS: / METAL SURFACES/ PLASTIC DEFORMATION/ POLYMERIC FILMS/ SIMULATORS

ABA: Author

ABS: A total hip simulator was used to determine the friction and wear properties of Charnley-type (316L stainless steel balls and sterile ultrahigh molecular weight polyethylene cups) hip prostheses. Three different sets of specimens were tested to 395,000, 101,500 and 233,000 walking cycles, respectively. All tests were run unlubricated, at ambient conditions (22 to 26 C, 30 to 50 percent relative humidity), at 30 walking cycles per minute, under a dynamic load simulating walking. Polyethylene cup wear rates ranged from 1.4 to 39 ten billions cu m which corresponds to dimensional losses of 4.0 to 11 microns per year. Although these wear rates are lower than those obtained from other hip simulators and from in vivo X-ray measurements, they are comparable when taking run-in and plastic deformation into account. Maximum tangential friction forces ranged from 93 to 129 N under variable load (267 to 3090 N range) and from

ENTER: EXPAND RN/NASA-TM-

# TRIBOLOGICAL MEASUREMENTS ON A CHARNLEY-TYPE ARTIFICIAL HIP JOINT

by William R. Jones, Jr.  
National Aeronautics and Space Administration  
Lewis Research Center  
Cleveland, Ohio

## SUMMARY

A total hip simulator was used to determine the friction and wear properties of Charnley-type (316L stainless steel balls and sterile ultrahigh molecular weight polyethylene cups) hip prostheses. Three different sets of specimens were tested to  $3.95 \times 10^5$ ,  $10.15 \times 10^5$ , and  $23.31 \times 10^5$  walking cycles, respectively. All tests were run unlubricated, at ambient conditions (22° to 26° C, 30 to 50 percent relative humidity), at 30 walking cycles per minute, under a dynamic load simulating walking.

Polyethylene cup wear rates ranged from 1.4 to  $3.9 \times 10^{-13}$  m<sup>3</sup>/m which corresponds to dimensional losses of 4.0 to 11 μm per year. Although these wear rates are lower than those obtained from other hip simulators and from in vivo X-ray measurements, they are comparable when taking run-in and plastic deformation into account. Maximum tangential friction forces ranged from 93 to 129 N under variable load (267 to 3090 N range) and from 93 to 143 N under a static load of 3090 N.

A portion of one test ( $2.5 \times 10^5$  walking cycles) run under dry air (<1 percent relative humidity) yielded a wear rate almost 6 times greater than that obtained under wet air (>70 percent relative humidity) conditions. The maximum friction force was about 13 percent higher in dry air compared to wet air.

Light microscopy revealed a rapid buildup (during the first 42 000 cycles) of a polymer transfer film on the metal surface. This transfer film remained relatively constant throughout the remainder of the test. Most of the wear debris consisted of fine (<100 μm) powdery particles which collected near the equator of the ball specimen.

## INTRODUCTION

The replacement of diseased or damaged human joints with artificial devices has become commonplace. During 1976 there were 80 000 hip replacements and 30 000 knee replacements in the USA (ref. 1). Most currently used prostheses consist of either a Co-Cr-Mo alloy (Vitallium) or surgical stainless steel (316L) articulating against ultrahigh molecular weight polyethylene (UHMWPE).

One of the more commonly used total hip devices consists of a 22 mm ball and stem femoral component and an UHMWPE acetabular cup. This device is usually referred to as the Charnley total hip replacement (refs. 2 and 3) after the pioneering English surgeon.

Many investigators (refs. 4 to 16), using a variety of different bench type instruments, have reported on the friction and wear properties of the commonly used prosthetic materials. However, there is a paucity of data (refs. 9, 17 to 22) on actual prostheses run on hip or knee simulators.

The objective of the investigation was to provide baseline friction and wear data on standard Charnley type prosthesis components (316L stainless

N83-32943#

E-1501

steel balls and UHMWPE cups) using the NASA total hip simulator. Tests were conducted unlubricated, and at ambient temperature (22° to 26° C). Other conditions included: a relative humidity (RH) of 30 to 50 percent, 30 walking cycles per minute, a variable load ranging from 267 to 3090 N and test durations to 1.8 million walking cycles.

## TEST SPECIMENS

Standard Charnley commercial cups were used for the acetabular test component. They were made from ultrahigh molecular weight polyethylene (UHMWPE) which had been sterilized by gamma irradiation (2.5 mRad dose). The femoral component consisted of a standard stainless steel (316L) 22 mm head with a special threaded base. This base, which took the place of the normal stem, was used for ease of rig assembly, disassembly and alignment. The hemispherical head was identical in size, shape, tolerance and surface finish to commercial femoral components. All test specimens were supplied by Zimmer-USA, Warsaw, Indiana. Photographs of the femoral and acetabular components are shown in figure 1.

## APPARATUS

The total hip simulator (fig. 2) was designed to accept various designs of full-size total hip prostheses or a ball and socket test specimen (fig. 3) and to simulate the motions (ref. 9), and the variable loads (refs. 9 to 11) encountered in the hip joint.

The femoral specimens were mounted in a fixture extending from the end of an oscillating shaft (fig. 3). Three types of oscillating motions are superimposed on the prosthesis: flexion-extension, abduction-adduction, and internal and external rotation (fig. 4). The shaft oscillates up to  $\pm 18^\circ$  and simulates the major extension and flexion of the hip joint in the sagittal plane of walking (fig. 4) (see ref. 9). The shaft was driven by a variable speed direct current motor and worm gear box in unidirectional rotation. An eccentric was mounted on the output shaft of the gear box and was adjustable to give the desired extension and flexion. An adjustable length crank arm was connected on one end to the gear box eccentric that allows positioning of the ball in the sagittal plane (fig. 4). The other end of the crank arm was connected to a larger eccentric on the simulator drive shaft and drove the main shaft in oscillating motion (fig. 2). The femoral specimen was mounted on a bearing assembly in the femoral ball fixture (fig. 3) perpendicular to the drive shaft. The inner bearing assembly holds the femoral ball. It has an arm extending radially from its center. The radial arm is restrained at the extended end and thus as the drive shaft oscillates the femoral specimen will oscillate in the transverse plane (fig. 4). For normal walking this oscillation is  $\pm 7^\circ$  (ref. 9). The amount of internal and external rotation is determined by the restraining location on the radial arm.

The acetabular cup was mounted in a fixture that was stabilized with flexures (fig. 2). These flexures carry the load applied to the prosthesis assembly and permit the acetabular cup to move in a third motion  $\pm 6^\circ$  (ref. 9) and simulate abduction and adduction motion of walking as encountered in the frontal plane (fig. 4). That simulated motion was transmitted with a push rod driven by a cam on the main drive shaft. The cam was designed for the desired motion of the acetabular cup. The acetabular cup fixture has a special

flexure suspension and force transducer that enables measurement of the friction force in the sagittal plane.

A variable load was applied by means of a hydraulic cylinder and hydraulic pump system through rods and main flexures. The hydraulic cylinder was controlled by a hydraulic servosystem and an electronic programmer. A strain gage type load cell with two strain gage bridges was connected mechanically to the hydraulic cylinder. One of the bridge circuits served as an electrical feedback to the hydraulic servovalve and servocontroller amplifier. The second strain gage bridge was used to measure the load. The load output was recorded on an oscillographic recorder.

## PROCEDURE

The femoral balls and acetabular cups were assembled (fig. 3) on the femoral ball fixture. The tests were run dry at room temperature (22-26° C) to produce a worse case wear situation. The standard test was then run at a gait of 30 walking cycles per minute (60 steps/min) and a variable load simulating walking. The loads ranged from 267 N (60 lb) to 3090 N (696 lb) and the load pattern was as shown in figure 5 for a single walking cycle. The friction force as a function of walking cycle was recorded at 2 hour intervals.

During each walking cycle, the tangential friction force at the ball-socket interface is continuously measured. A saw toothed curve normally results with one spike representing the maximum friction as the ball rotates in one direction and a second or negative spike representing the maximum friction as the ball rotates in the opposite direction. Normally, these curves are fairly symmetrical and therefore the maximum friction force is taken as one-half the peak to peak value.

Three different friction and wear tests were performed, each with a new set of test components. Short, intermediate, and long term tests were completed to 576 000, 1 015 000, and 1 829 000 walking cycles, respectively. Tests were interrupted at various intervals for weight loss measurements and examination of the ball surfaces by light microscopy. At each shutdown, friction force measurements were performed at constant loads ranging from 123 N (28 lb) to 3090 N (696 lb).

All weight loss measurements were made on an analytical balance having a sensitivity of 10  $\mu\text{g}$ . Both control and sample cup measurements were made. Controls were used to eliminate weighing errors due to small changes in humidity. Both cups were weighed prior to the test, at various intervals during the test and at test conclusion. After a test interval, the difference in weight between the control and sample cup was obtained. After the next interval a second difference in weight was recorded. Then the difference between these two differences was considered as the wear weight loss. The average precision of the measurements was  $\pm 70 \mu\text{g}$ . A summary of the various test conditions is presented in table I.

## RESULTS AND DISCUSSION

Table II summarizes the friction and wear results for each test. This table includes the maximum tangential friction forces both during gait (dynamic load) and at a constant load of 3090 N for most test intervals. Incremental wear is reported both as a weight loss ( $\mu\text{g}$ ) and as a wear rate ( $\text{m}^3/\text{m}$  or  $\mu\text{m}/\text{yr}$ ). And finally, an average wear rate based on a straight line

fit to all data points appears as the wear slope in  $m^3/m$ . An equivalent dimensional wear rate ( $\mu m/yr$ ) is calculated from the wear slope. These calculations are based on a projected prosthesis contact area of  $3.8 \times 10^{-4} m^2$  and  $1.07 \times 10^4$  meters of sliding per year of use (ref. 15).

#### Friction Force During Gait

A typical set of oscillographic traces of the tangential friction force and normal load during gait are presented in figure 6 for four test durations (test 2). The friction pattern is characterized by a double peak during the support phase of the walking cycle. These two peaks directly correspond to the two primary peaks in the load cycle. During the swing phase, as the direction of motion in the prosthesis reverses, a negative friction peak occurs.

A similar set of friction traces for test 3A appear in figure 7. These traces are very similar to those of test 2 (fig. 6). Test 1 also yielded similar data and as indicated in table II, the maximum tangential friction force was fairly constant for each test. By averaging the tangential friction force data for each interval, one obtains the following: test 1 - 119 N, test 2 - 107 N, and test 3A - 107 N.

#### Friction Force at Constant Load

Tangential friction force traces for various constant loads after  $15.40 \times 10^5$  walking cycles during test 3A appear in figure 8. Here, at constant load, a nearly symmetrical (negative-positive) trace results. The maximum friction force at a constant load of 3090 N appears in table II for most test intervals. Values of tangential friction force (table II) for tests 1, 2, and 3A, range from 85 to 143 N and in general reflect the values obtained during gait under the variable load.

#### Incremental Wear Measurements

Acetabular cup weight losses are listed for most intervals in table II. The average precision of these measurements, as previously mentioned, was about  $\pm 70 \mu g$ , regardless of the amount of wear. Obviously, there is a greater uncertainty in the lower weight measurements than in the higher values. The incremental wear volumes ( $m^3$ ) are plotted as a function of sliding distance (m) in figure 9 for each test and the two sub-tests 3B and 3C. The best straight line fit to the data points was obtained for tests 1 and 3A and two straight line segments were fit for test 2. Correlation coefficients of these fits ranged from 0.9959 to 0.9999. Wear slopes ranged from 1.4 to  $3.9 \times 10^{-13} m^3/m$ . The slope of these lines ( $m^3/m$ ) also appears in table II.

Since the literature often quotes wear rates of prostheses as depth of wear per year of use, these slopes have been converted into these units in table II. The values range from 4 to 11  $\mu m/yr$ .

#### Dry Air Results

Tests 1, 2, and 3A were run in room air which had a relative humidity (RH) of 30 to 50 percent. In test 3B, a continuation of 3A, a dry air (<1 percent RH) atmosphere was used. In comparison to test 3A, the dry air atmosphere caused an increase in friction force and an increase in wear rate (table II).

## Wet Air Results

In test 3C, a wet air atmosphere was generated by bubbling dry air through a water reservoir. This yielded a wet air atmosphere (>70 percent RH). In this test both friction and wear were reduced compared to test 3A. The wear rate was about 1/6 of that obtained under dry air conditions. Oscillographic friction traces for both tests 3B and 3C appear in figure 10.

## Light Microscopy

The polar surface of the femoral ball specimens was examined by light microscopy after the various test intervals. The inner surface of the acetabular cup was not examined. A photomicrograph of the polar area of a new femoral ball is presented in figure 11. Except for a few surface scratches, the highly polished surface is devoid of any features. A series of photomicrographs taken during test 3A is presented in figure 12. A polymer transfer film is rapidly established during the first 42 000 cycles with only small changes thereafter. From the interference fringes the thickness of these films is estimated to vary from 0.4 to 0.8  $\mu\text{m}$ . Other surface features include dark thick (7 to 10  $\mu\text{m}$ ) deposits which may represent back transferred particles. These patches are relatively unchanging throughout the test.

The effect of atmosphere on transfer is illustrated in figure 13. Here the same polar area is photographed in room air (at 1829 K cycles), dry air (at 2079 K cycles) and finally wet air conditions (at 2331 K cycles). It is apparent that transfer is less under the dry conditions since previous transfer is actually removed. In contrast, in wet air, transfer is reestablished (fig. 13(c)).

## Wear Debris Morphology

At least four types of debris were observed. Fibrils (fig. 14), the dark patches (fig. 15), large birefringent particles (fig. 16), and finally a powdery debris (fig. 17). The majority of wear particles occurred as a finely divided powder which accumulated near the equator of the ball specimen. Fibrils were only occasionally seen. The dark patches formed early in the test (~42K cycles) and normally did not change during the remainder of the test. The large (<100  $\mu\text{m}$ ) birefringent particles were observed throughout the tests.

## Ball Surface Wear Pattern

A typical wear pattern on the femoral ball surface is illustrated in figure 18. Actually, this pattern represents the transfer film along with some surface scratching. Little or no wear occurs on this surface. The long scratches are in the direction of the flexion-extension motion of walking. Their curvature is due to the superimposed abduction-adduction motion.

## Wear Mechanisms

A variety of wear mechanisms have been postulated to occur in artificial hip components (metal-plastic couples). However, the most commonly reported mechanisms are adhesion, abrasion, and fatigue (ref. 29).

Adhesive wear involves transfer of polymer to the metal counterface by adhesive forces. This would result in the formation of a transfer film which is obviously occurring in this study and has been observed by many others (refs. 5, 11, 13, 14, 16, 23, 28).

Abrasive wear involves the removal of a softer material by a harder counterface (two body wear) or by a hard particle interposed between the surfaces (three body wear). This mechanism would produce grooves in the polymer surface in the direction of sliding. Since the polymer cup was not examined in these studies, this mechanism can not be verified. However, since the majority of the wear debris was in the form of small powdery particles, it does not appear to be a dominant mode.

Fatigue wear is characterized by cumulative surface damage caused by the alternating stress pattern. The fine powdery wear particles observed in this study were also observed by Atkinson, et. al. (ref. 13). They attributed this type of debris to a fatigue-like mechanism. In their work they reported an increased wear rate in the latter stages of their tests (Section B wear). The powdery debris only occurred in this wear region, thus they concluded that Section B wear was the onset of fatigue contribution to the overall wear rate. Wear rates increased from 30 to 100 percent in the Section B regime. Test 2 of the present study yielded an increased wear rate similar to that reported by Atkinson, et at. However, the powdery debris was observed in all three tests at all stages. If this type of debris is indeed produced by a fatigue process, then this process is occurring early in the wear test.

#### Friction as a Function of Time

In general, the maximum tangential friction force did not change appreciably with time. This is based on the variable load data (table II). This agrees with Fusaro (ref. 16) where the coefficient of friction stabilized (after run-in) in pin-on-disk tests. Similar results were also obtained by the author with a Vitallium - UHMWPE couple in a joint simulator (ref. 28) and in pin-on-disk tests (ref. 14).

#### Friction as a Function of Load

The coefficient of friction as a function of load for test 3A (after 1829 K cycles) is presented in figure 19. The coefficient of friction was measured at constant load. The peak to peak friction force (see fig. 8) was halved and divided by the appropriate load. The coefficient of friction decreases with increasing load. This behavior is common to metal-plastic couples where there is partial elastic and partial plastic deformation occurring.

Similar friction curves are reproduced in figure 19 from Weightman, et. al. (ref. 20) for a Charnley prosthesis both unlubricated (upper curve) and lubricated with serum (lower curve). As can be seen, the unlubricated data of this work corresponds more closely to the serum lubricated reference data.

#### CONCLUDING REMARKS

The reference wear data (table III) indicates that the wear data from the present study (i.e., 4 to 11  $\mu\text{m}/\text{yr}$ ) is much lower than that obtained by other researchers. However, some important points should be noted.

First, the Swikert-Johnson data (ref. 23) were based on very short duration tests (8 hr). Therefore, their wear data (420  $\mu\text{m}/\text{yr}$ ) really represents run-in wear which is typically much higher than longer duration tests. The Duff-Barclay and Spillman data (ref. 21) of 18  $\mu\text{m}/\text{yr}$  compares more favorably since these tests of much longer duration (200 to 500 hr).



On the other hand, the similar tests of Weightman, et al. (ref. 20) and the in vivo measurements of Charnley (refs. 24 to 26) used dimensional changes to calculate wear rates. Obviously these dimensional changes include plastic deformation. An estimate was made in the Weightman study (ref. 20) that from 1.5 to 30  $\mu\text{m}/\text{yr}$  was due to wear. The present wear data falls within this range. It would appear that our unlubricated tests run in moist air yield results (friction and wear) similar those obtained with serum lubrication.

#### SUMMARY OF RESULTS

A total hip simulator was used to determine the friction and wear properties of Charnley-type hip prostheses. Results are summarized as follows:

1. Wear rates of the polyethylene cup range from 1.4 to  $3.9 \times 10^{-13}$   $\text{m}^3/\text{m}$ . This corresponds to 4.0 to 11  $\mu\text{m}$  per year.
2. These wear rates are lower than those obtained in other hip simulators and from in vivo X-ray measurements. However, when one takes into account run-in effects and plastic deformation, the results are comparable.
3. Maximum tangential friction forces ranged from 93 to 129 N under dynamic load and from 93 to 143 N under a constant load of 3090 N.
4. A portion of one test run under dry air (<1 percent RH) conditions yielded a wear rate almost 6 times that obtained under wet air (>70 percent RH) conditions. The maximum friction force was about 13 percent higher in dry air compared to wet air.
5. Polymer transfer films were rapidly (during the first 42 000 cycles) established on the ball surface and remained stable throughout the remainder of the test.
6. Wear debris mainly consisted of fine (<100  $\mu\text{m}$ ) powdery particles which collected near the equator of the ball specimen.

#### REFERENCES

1. Sonstegard, D. A.; Matthews, L. S.; and Kaufer, H.: The Surgical Replacement of the Human Knee Joint. *Sci. Am.*, vol. 238, no. 1, Jan. 1978, pp. 44-51.
2. Charnley, J.: Arthroplasty of the Hip - A New Operation. *The Lancet*, vol. 1, May 27, 1961, pp. 1129-1132.
3. Charnley, J.: Factors in the Design of an Artificial Hip Joint. *Proc. Inst. Mech. Eng. (London)*, vol. 181, pt.3J, 1966-67, pp. 104-111.
4. Amstutz, H. C.: Polymers as Bearing Materials for Total Hip Replacement: A Friction and Wear Analysis. *J. Biomed. Mater. Res.*, vol. 3, no. 3, 1968, pp. 547-568.
5. Seedhom, B. B.; Dowson, D.; and Wright, V.: Wear of Solid Phase Formed High Density Polyethylene in Relation to the Life of Artificial Hips and Knees. *Wear*, vol. 24, 1973, pp. 35-51.
6. Miller, D. A., et. al.: A Comparative Evaluation of the Wear of Ultra-High Molecular Weight Polyethylene Abraded by Ti-6Al-4V. *Wear*, vol. 28, 1974, pp. 207-216.
7. Shen, C.; and Dumbleton, J. H.: The Friction and Wear Behavior of Irradiated Very High Molecular Weight Polyethylene. *Wear*, vol. 30, 1974, pp. 349-364.
8. Beutler, H.; Lehmann, M.; and Stahli, G.: Wear Behavior of Medical Engineering Materials. *Wear*, vol. 33, 1975, pp. 337-350.

9. Ungeth, M.: Requirements of Operational Tests and Test Results in Total Hip and Knee Arthroplasty. *Advances in Artificial Hip and Knee Joint Technology. Engineering in Medicine*, vol. 2, M. Schaldach and D. Hohmann, eds., Springer-Verlag (Berlin), 1976, pp. 493-518.
10. Rostoker, W.; and Galante, J. O.: Some New Studies of the Wear Behavior of Ultra-High Molecular Weight Polyethylene. *J. Biomed. Mater. Res.*, vol. 10, no. 2, Mar. 1976, pp. 303-310.
11. Dumbleton, J. H.; and Shen, C.: The Wear Behavior of Ultra-High Molecular Weight Polyethylene. *Wear*, vol. 37, 1976, pp. 279-289.
12. McKellop, H., et. al.: Wear Characteristics of UHMW Polyethylene: A Method for Accurately Measuring Extremely Low Wear Rates. *J. Biomed. Mater. Res.*, vol. 12, no. 6, Nov. 1978, pp. 895-927.
13. Atkinson, J. R.; Brown, K. J.; and Dowson, D.: The Wear of High Molecular Weight Polyethylene. Part I: The Wear of Isotropic Polyethylene Against Dry Stainless Steel in Unidirectional Motion. *J. Lubr. Technol.*, vol. 100, no. 2, Apr. 1978, pp. 208-218.
14. Jones, W. R.; Hady, W. F.; and Crugnola, A.: Effect of  $\gamma$ -Irradiation on the Friction and Wear of Ultrahigh Molecular Weight Polyethylene. *Wear*, vol. 70, 1981, pp. 77-92.
15. McKellop, H., et. al.: Friction and Wear Properties of Polymer, Metal, and Ceramic Prosthetic Joint Materials Evaluated on a Multichannel Screening Device. *J. Biomed. Mater. Res.*, vol. 15, no. 5, Sept. 1981, pp. 619-653.
16. Fusaro, R. L.: Effect of Sliding Speed and Contact Stress on Tribological Properties of Ultra-High-Molecular-Weight Polyethylene. NASA TP 2059, Nov. 1982.
17. Dumbleton, J. H.; Miller, D. A.; and Miller, E. H.: A Simulator for Load Bearing Joints. *Wear*, vol. 20, 1972, pp. 165-174.
18. Swanson, S. A. V.; Freeman, M. A. R.; and Heath, J. C.: Laboratory Tests on Total Joint Replacement Prostheses. *J. Bone Jt. Surg.*, vol. 55B, no. 4, Nov. 1973, pp. 759-773.
19. Walker, P. S.; and Salvati, E.: The Measurement and Effects of Friction and Wear in Artificial Hip Joints. *J. Biomed. Mat. Res.*, vol. 7, no. 3, 1973, pp. 327-342.
20. Weightman, B. O., et. al.: A Comparative Study of Total Hip Replacement Prosthesis. *J. Biomech.*, vol. 6, no. 3, 1973, pp. 299-311.
21. Duff-Barclay, I.; and Spillman, D. T.: Total Human Hip Joint Prostheses - A Laboratory Study of Friction and Wear. *Proc. Inst. Mech. Eng.* (London), vol. 181, pt.3J, 1966-67, pp. 90-103.
22. Clarke, I. C.: Wear of Artificial Joint Materials IV. Hip Joint Simulator Studies, *Eng. Med.*, vol. 10, no. 4, Oct. 1981, pp. 189-198.
23. Swikert, M. A.; and Johnson, R. L.: Simulated Studies of Wear and Friction in Total Hip Prosthesis Components with Various Ball Sizes and Surface Finishes. NASA TND-8174, Mar. 1976.
24. Charnley, J.: Low Friction Arthroplasty of the Hip Joint. *J. Bone and Jt. Surg.*, vol. 53B, 1971, pp. 149.
25. Charnley, J.; and Cupric, Z.: The Nine and Ten Year Results of the Low Friction Arthroplasty of the Hip. *Clin. Orthop. Relat. Res.*, vol. 95, 1973, pp. 9-25.
26. Charnley, J.; and Halley, D.K.: Rate of Wear in Total Hip Replacement. *Clin. Orthop. Relat. Res.*, vol. 112, Oct. 1975, pp. 170-179.
27. Rose, R. M., et. al.: On the True Wear Rate of Ultra High-Molecular-Weight Polyethylene in the Total Hip Prosthesis. *J. Bone Jt. Surg.*, vol. 62A, 1980, pp. 537-549.

28. Jones, W. R., Jr.; Roberts, J. C.; and Ling, F. F.: Tribological Characteristics of a Composite Total-Surface Hip Replacement, NASA TP-1853, Jan. 1982.
29. Dumbleton, J. C.: Tribology of Natural and Artificial Joints, Tribology Series, vol. 3, Elsevier (Amsterdam), 1981.

TABLE I. - SUMMARY OF TEST CONDITIONS

Test <sup>a</sup>	Atmosphere	Total test duration walking cycles, m
1	Room air (30 to 50 percent relative humidity [RH])	$5.76 \times 10^5$ (7950)
2	Room air (30 to 50 percent relative humidity [RH])	$10.15 \times 10^5$ (14 000)
3A	Room air (30 to 50 percent relative humidity [RH])	$18.29 \times 10^5$ (25 200)
3B	Dry air (<1 percent RH)	$2.50 \times 10^5$ (3450)
3C	Wet air (>70 percent RH)	$2.53 \times 10^5$ (3490)

<sup>a</sup>All tests were unlubricated; room temperature (22° to 26° C), 30 walking cycles per minute, variable load simulating walking, 267 to 3090 N).

TABLE II. - SUMMARY OF FRICTION AND WEAR RESULTS

Test	Incremental test duration, cycles	Maximum tangential friction force, N		Incremental weight loss, $\mu\text{g}$	Incremental wear rate, $\text{m}^3/\text{m}$	Wear slope		Relative humidity
		Variable load	Constant load (3090 N)			$\text{m}^3/\text{m}$	$\mu\text{m}/\text{yr}$	
1	0-0.42x10 <sup>5</sup>	129±11 <sup>a</sup>	143	<sup>c</sup> 880	16x10 <sup>-13</sup>	2.3x10 <sup>-13</sup>	6.5	30-50
	0.42-2.15	123±5	nm <sup>b</sup>	520	2.3			
	2.15-3.95	105±3	nm <sup>b</sup>	510	2.2			
	3.95-5.76	120±6	nm <sup>b</sup>	nm <sup>b</sup>	nm <sup>b</sup>			
2	0-0.42	101±3	104	134	2.4	1.4	4.0	30-50
	0.42-2.52	105±4	100	371	1.3			
	2.52-5.0	108±4	104	471	1.4			
	5.0-7.53	113±4	100	1041	3.2			
	7.53-10.15	108±6	85	1370	4.1			
3A	0-0.42	113±4	104	nm <sup>b</sup>	nm <sup>b</sup>	3.9	11	30-50
	0.42-2.5	107±4	98	557	2.0			
	2.5-5.0	105±3	102	973	3.0			
	5.0-7.5	93±4	97	1795	5.6			
	7.5-10.15	104±3	93	940	2.8			
	10.15-12.51	104±5	108	1685	5.2			
	12.51-15.40	112±9	100	1218	3.2			
15.40-18.29	114±6	97	1012	2.7				
3B	18.29-20.79	116±5	122	2445	7.5	7.5	21	< 1
3C	20.79-23.31	103±6	93	435	1.3	1.3	3.7	> 70

<sup>a</sup>Standard deviation.

<sup>b</sup>Not measured.

<sup>c</sup>Average precision ±70  $\mu\text{g}$ .

TABLE III. - REFERENCE WEAR RATES

Reference	Wear rate, $\mu\text{m}/\text{yr}$	Notes
Swikert and Johnson (ref. 23)	420	Unlubricated, gravimetric, acetabular cup not sterilized, short duration test - 14 400 cycles
Duff-Barclay and Spillman (ref. 21)	18	Unlubricated, gravimetric
Weightman, et al. (ref. 20)	150 (1.5 to 30) <sup>a</sup>	Bovine serum lubrication, wear measured by dimensional changes
Charnley, et al. (refs. 24 to 26)	120 to 150	In vivo wear measured by X-rays

<sup>a</sup>Estimate of dimensional change due to wear (ref. 27).

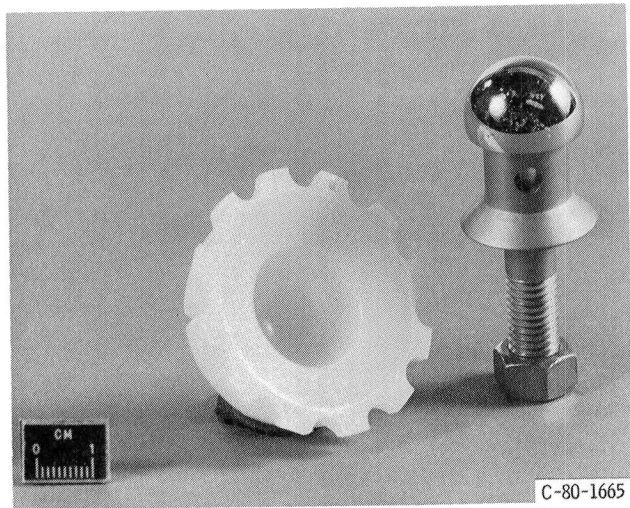

Figure 1. - Charney femoral and acetabular test components.

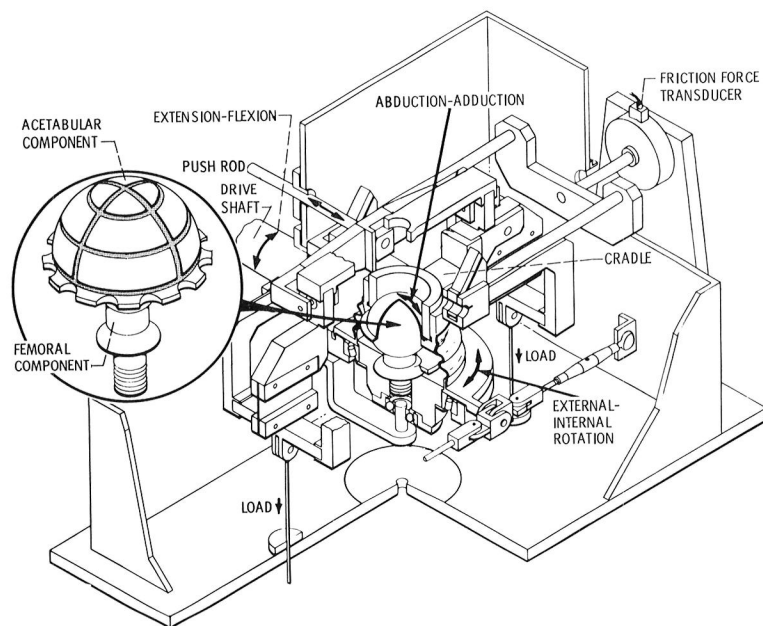

Figure 2. - Perspective and partial cutaway view of total hip simulator with prosthesis specimens, showing directions of motion and load.

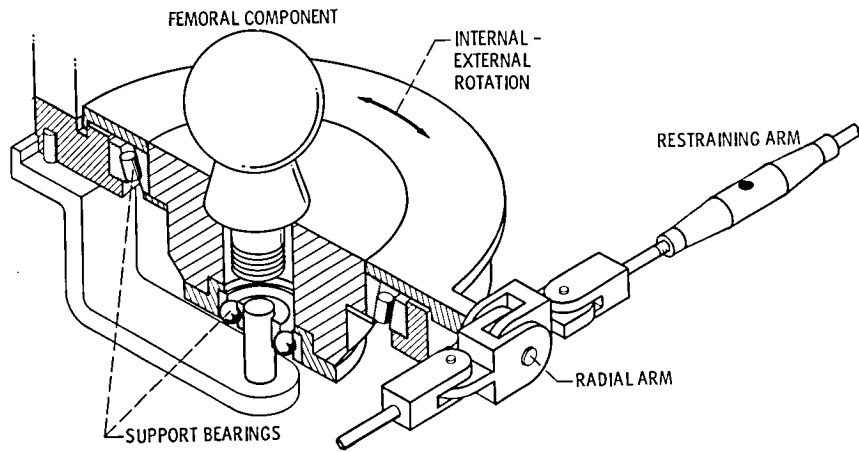

Figure 3. - Test fixture for femoral specimen.

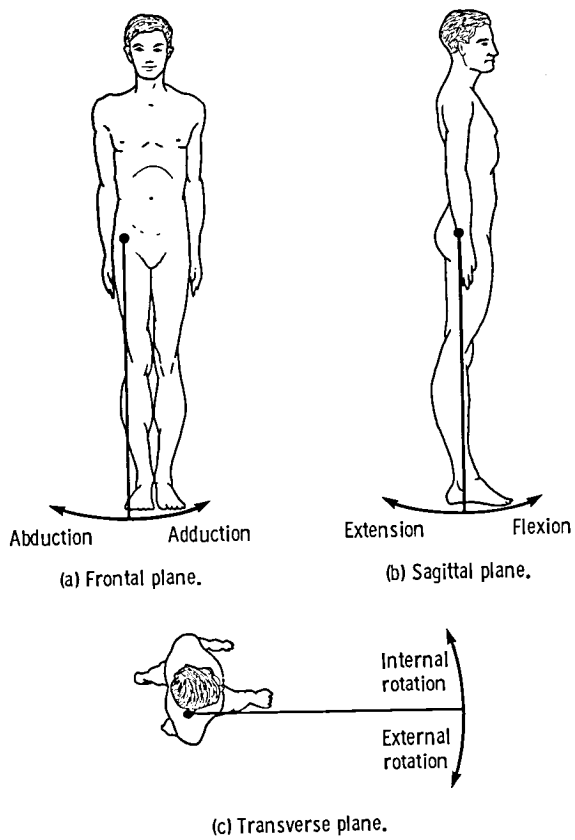

Figure 4. - Planes and motions of the hip joint (ref. 21).



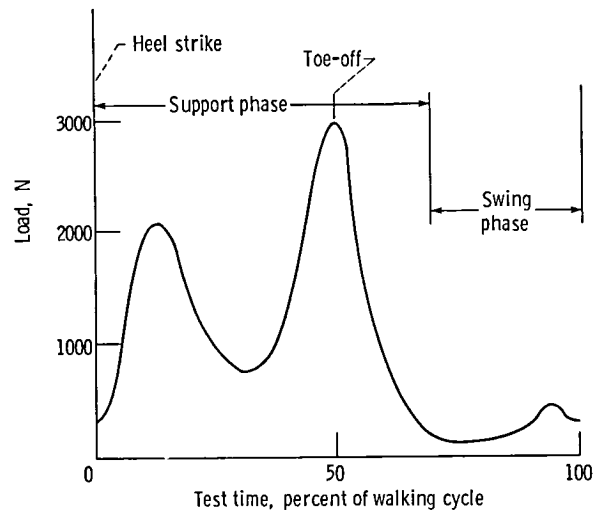

Figure 5. - Hip joint loads during gait.

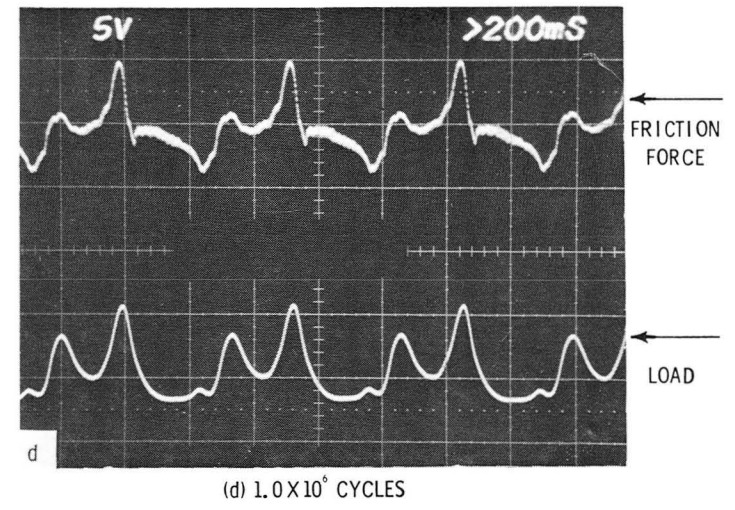
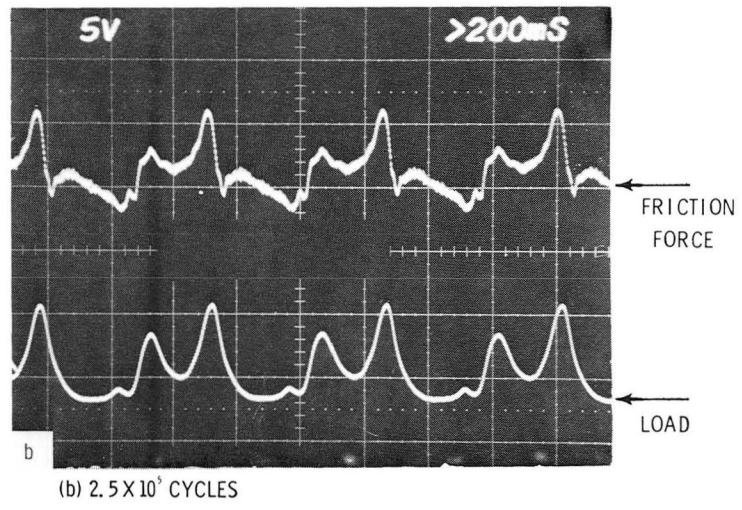
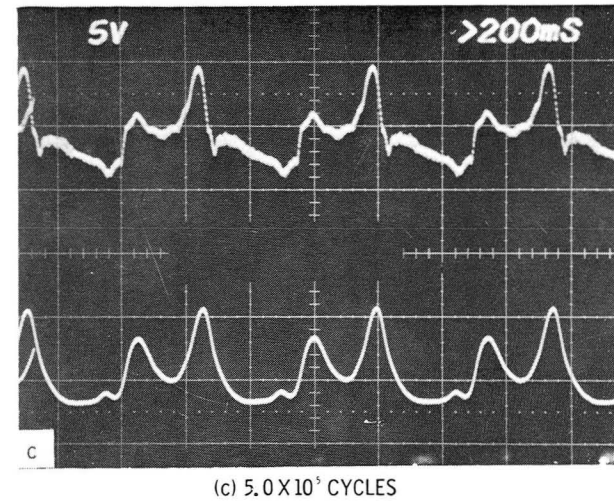
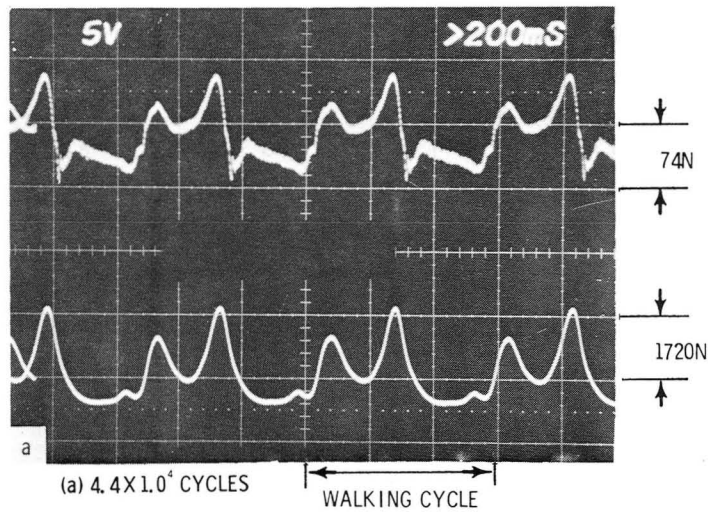
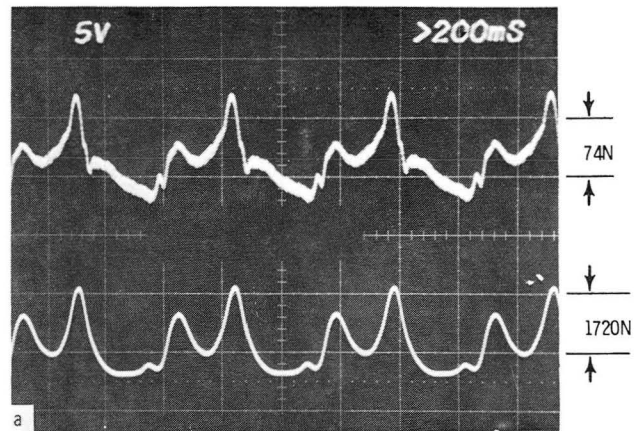
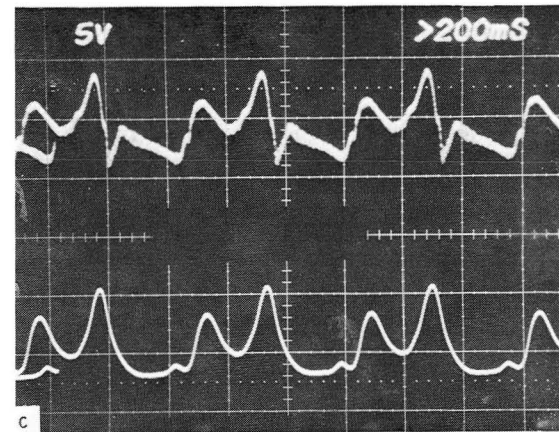

Figure 6. - Tangential friction force and programmed load at various test durations (test 2).

Figure 6. - Concluded.



(a)  $4.2 \times 10^4$  CYCLES



(c)  $1 \times 10^6$  CYCLES

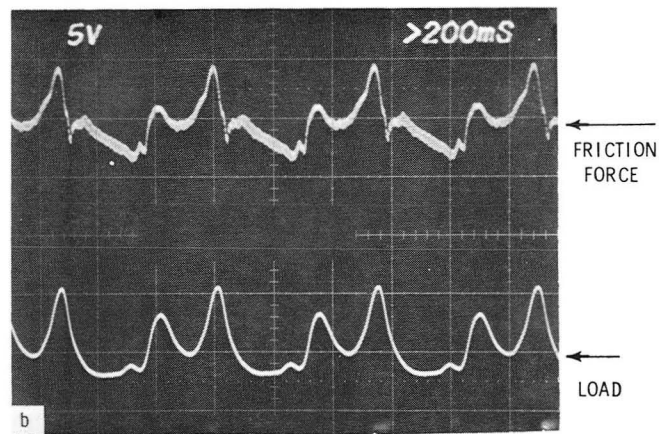

(b)  $5.0 \times 10^5$  CYCLES

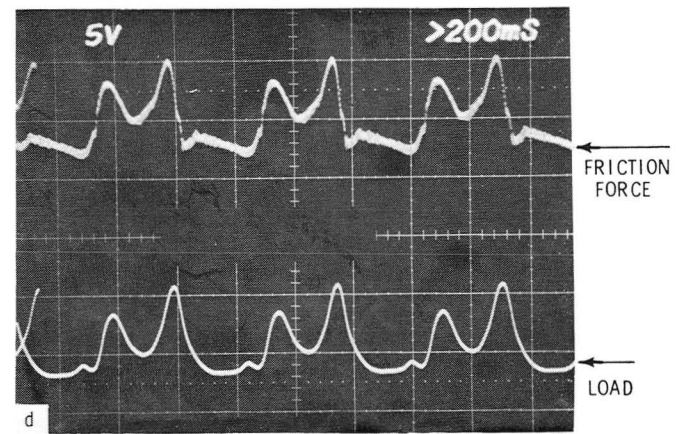

(d)  $1.54 \times 10^6$  CYCLES

Figure 7. - Tangential friction force and programmed load at various test durations (test 3A).

Figure 7. - Concluded.

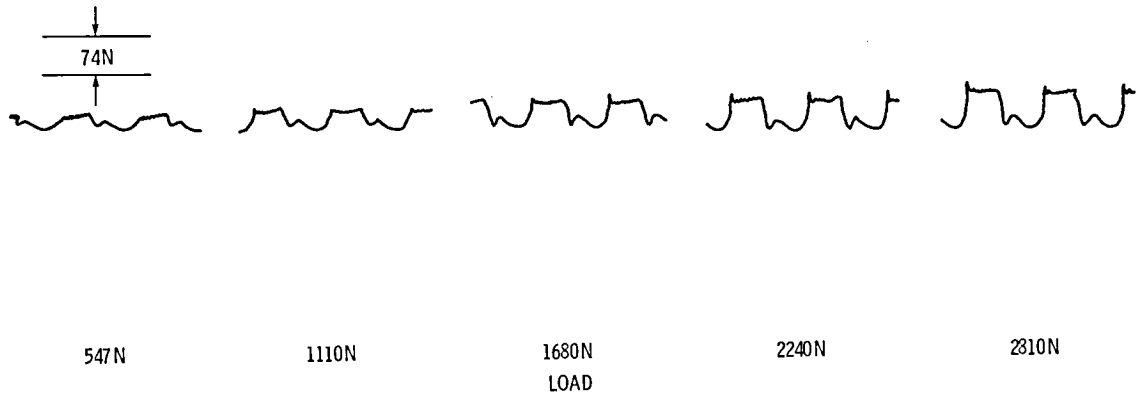

Figure 8. - Tangential friction force at various constant loads for test 3A (post  $15.40 \times 10^5$  walking cycles).

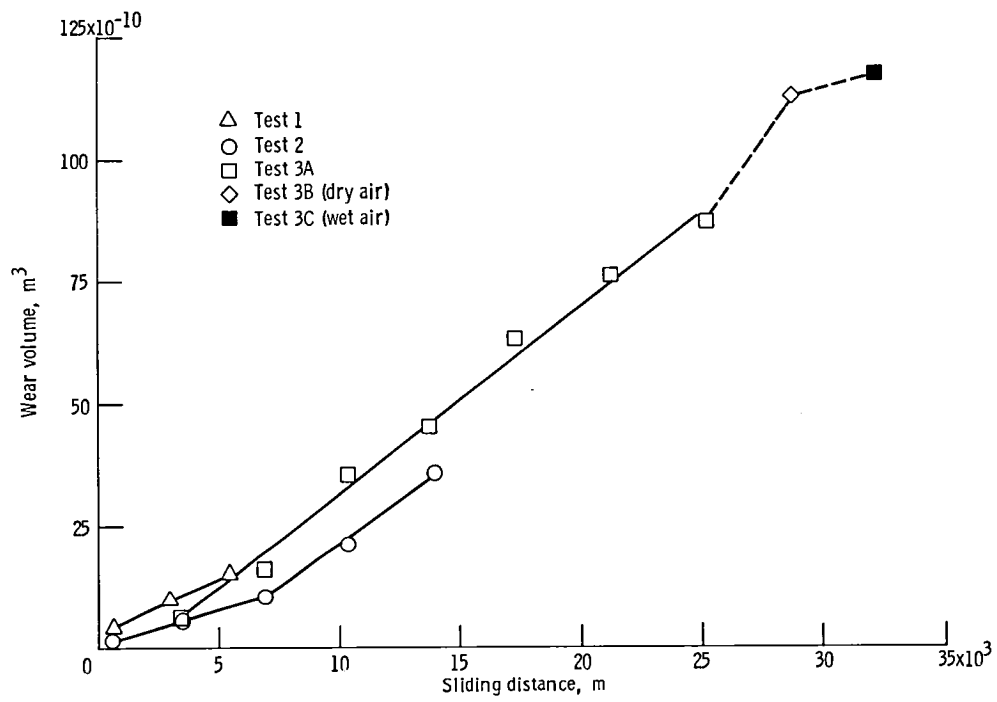
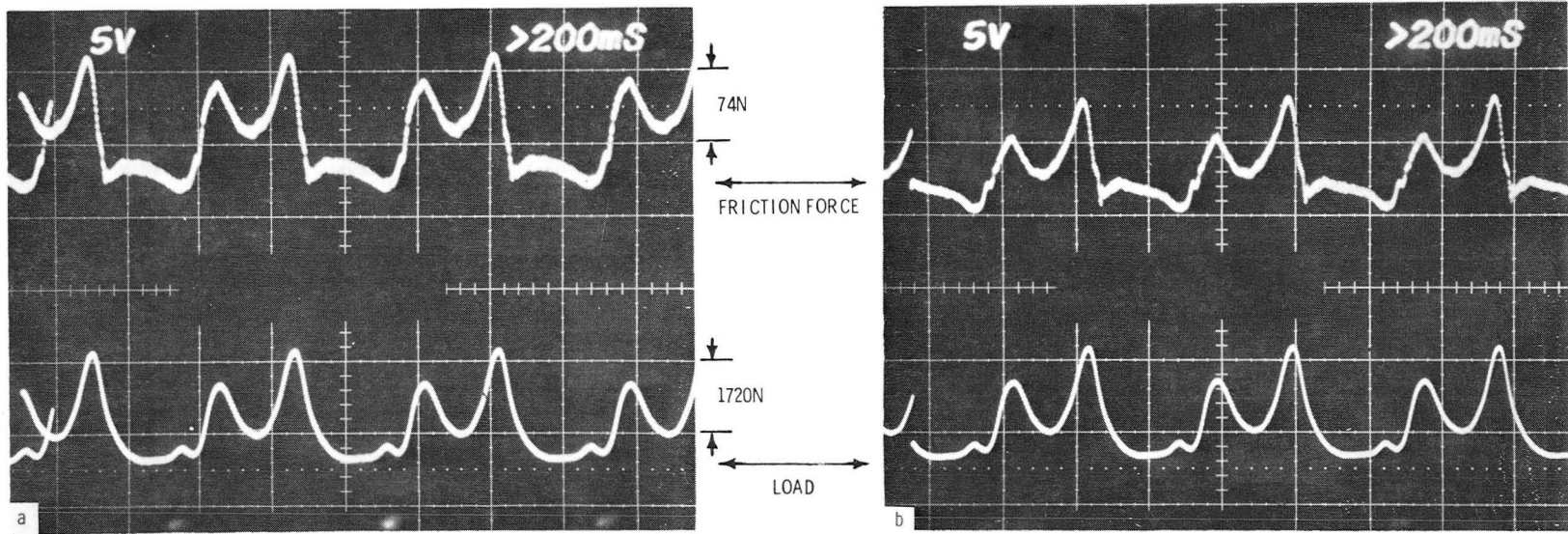

Figure 9. - Wear volume as a function of sliding distance.



(a) DRY AIR (<10% RH, test 3B).

(b) WET AIR (>70% RH, test 3C).

Figure 10. - Tangential friction force and programmed load for test atmospheres of dry and wet air.

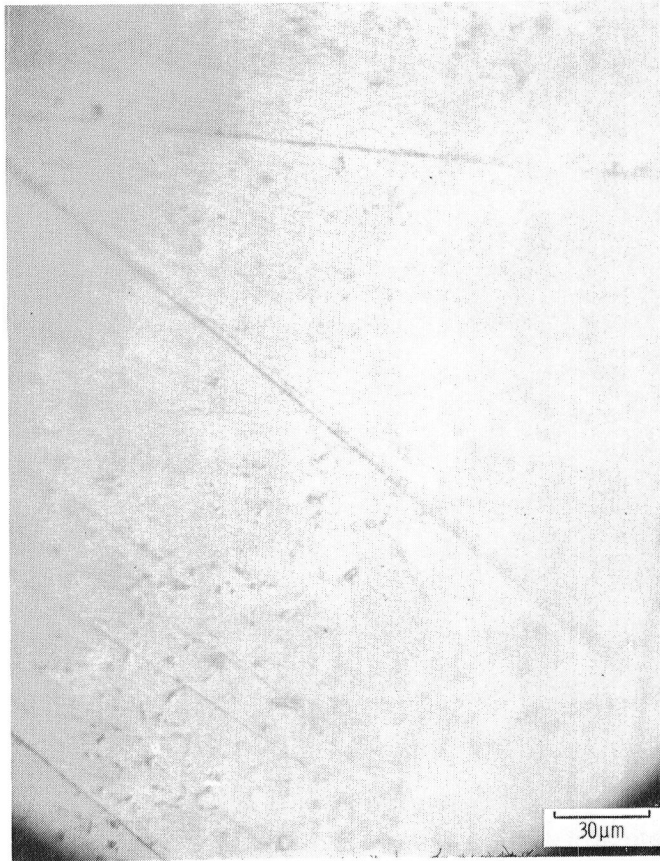

Figure 11. - Polar surface of new femoral ball (test 3, pretest).



(a) 42K CYCLES



(b) 127K CYCLES

Figure 12. - Polar surface of femoral ball after various test intervals (test 3A).



(c) 500K CYCLES

Figure 12. - Concluded.





(a) ROOM AIR (1829K CYCLES)



(b) DRY AIR (2079K CYCLES)

Figure 13. - Polar surface of femoral ball after various test intervals in room air (test 3A, dry air (test 3B) and wet air (test 3C).



C

(c) WET AIR (2331K CYCLES)

Figure 13. - Concluded.



Figure 14. - Fibril type of wear debris (test 1, 42K cycles).



Figure 15. - Dark patch type of wear debris (test 2, 1015K cycles).

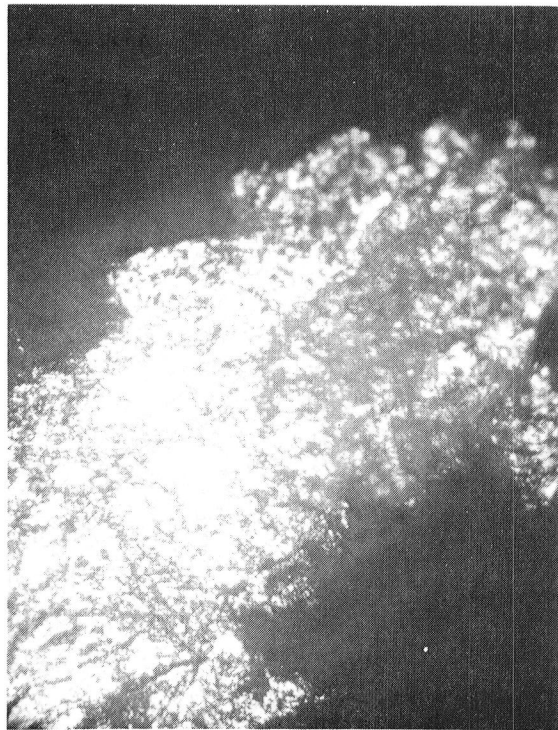

Figure 16. - Birefringent type of wear debris (test 3A, post 250K cycles).

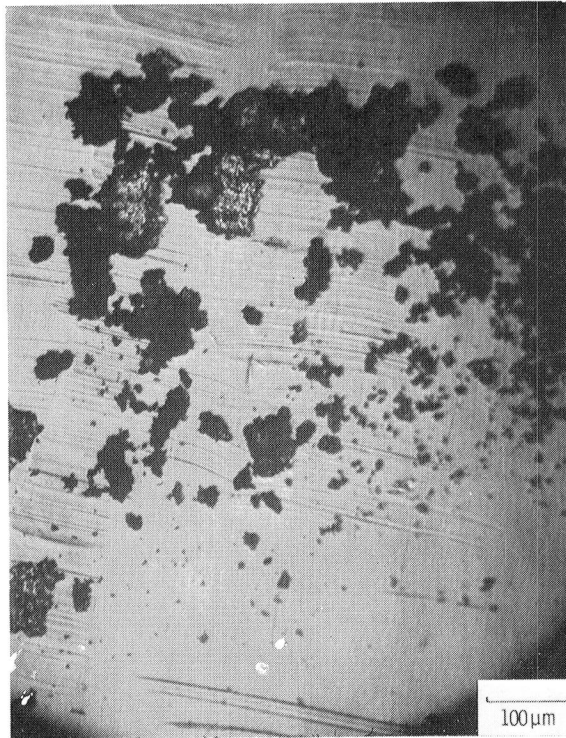

Figure 17. - Powdery type of wear debris (test 3B, 2079K cycles).

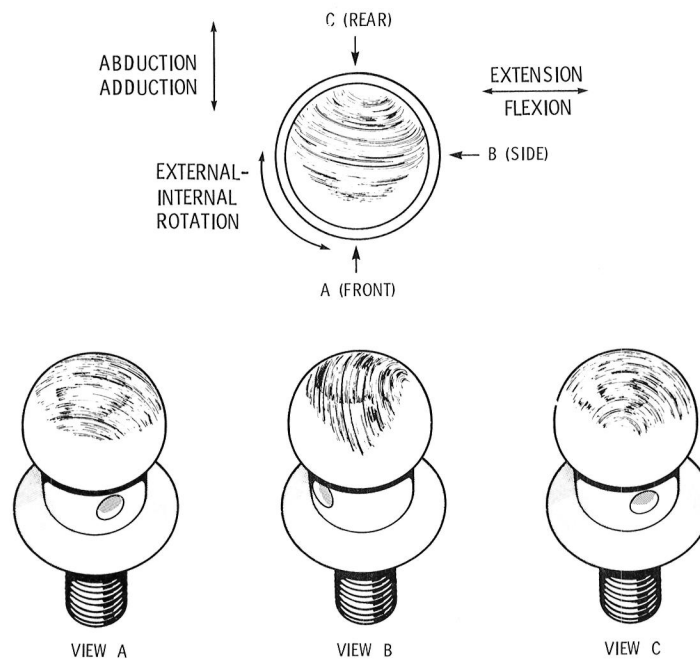

Figure 18. - Typical ball surface wear pattern.

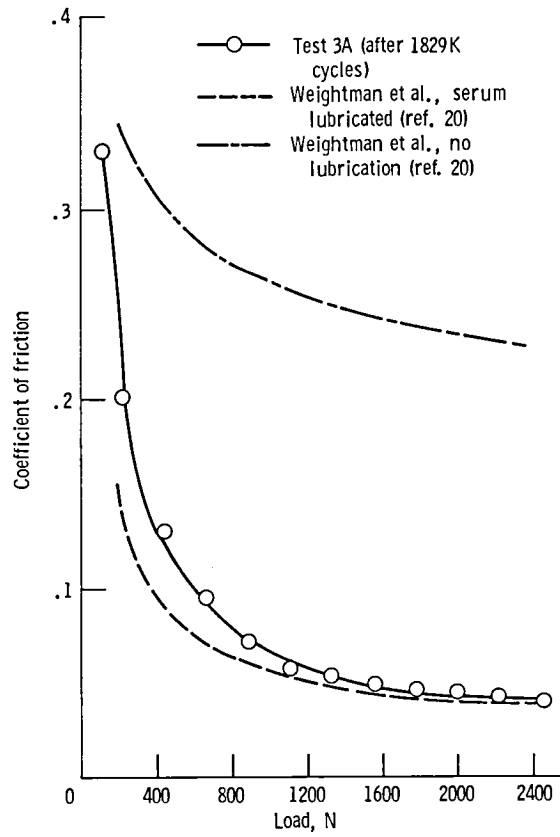

Figure 19. - Coefficient of friction as a function of load.

1. Report No. NASA TM-83440	2. Government Accession No.	3. Recipient's Catalog No.	
4. Title and Subtitle Tribological Measurements on a Charnley-Type Artificial Hip Joint		5. Report Date July 1983	
		6. Performing Organization Code 505-32-42	
7. Author(s) William R. Jones, Jr.		8. Performing Organization Report No. E-1501	
		10. Work Unit No.	
9. Performing Organization Name and Address National Aeronautics and Space Administration Lewis Research Center Cleveland, Ohio 44135		11. Contract or Grant No.	
		13. Type of Report and Period Covered Technical Memorandum	
12. Sponsoring Agency Name and Address National Aeronautics and Space Administration Washington, D.C. 20546		14. Sponsoring Agency Code	
		15. Supplementary Notes	
16. Abstract A total hip simulator was used to determine the friction and wear properties of Charnley-type (316L stainless steel balls and sterile ultrahigh molecular weight polyethylene cups) hip prostheses. Three different sets of specimens were tested to $3.95 \times 10^5$ , $10.15 \times 10^5$ , and $23.31 \times 10^5$ walking cycles, respectively. All tests were run unlubricated, at ambient conditions ( $22^\circ$ to $26^\circ$ C, 30 to 50 percent relative humidity), at 30 walking cycles per minute, under a dynamic load simulating walking. Polyethylene cup wear rates ranged from 1.4 to $3.9 \times 10^{-13}$ m <sup>3</sup> /m which corresponds to dimensional losses of 4.0 to 11 $\mu$ m per year. Although these wear rates are lower than those obtained from other hip simulators and from in vivo X-ray measurements, they are comparable when taking run-in and plastic deformation into account. Maximum tangential friction forces ranged from 93 to 129 N under variable load (267 to 3090 N range) and from 93 to 143 N under a static load of 3090 N. A portion of one test ( $2.5 \times 10^5$ walking cycles) run under dry air (<1 percent relative humidity) yielded a wear rate almost 6 times greater than that obtained under wet air (>70 percent relative humidity) conditions. The maximum friction force was about 13 percent higher in dry air compared to wet air. Light microscopy revealed a rapid buildup (during the first 42 000 cycles) of a polymer transfer film on the metal surface. This transfer film remained relatively constant throughout the remainder of the test. Most of the wear debris consisted of fine (<100 $\mu$ m) powdery particles which collected near the equator of the ball specimen.			
17. Key Words (Suggested by Author(s)) Hip prosthesis Friction Wear		18. Distribution Statement Unclassified - unlimited STAR Category 27	
19. Security Classif. (of this report) Unclassified	20. Security Classif. (of this page) Unclassified	21. No. of pages	22. Price*

National Aeronautics and  
Space Administration

Washington, D.C.  
20546

Official Business  
Penalty for Private Use, \$300

SPECIAL FOURTH CLASS MAIL  
BOOK



Postage and Fees Paid  
National Aeronautics and  
Space Administration  
NASA-451

**NASA**

POSTMASTER: If Undeliverable (Section 158  
Postal Manual) Do Not Return

---