

**NASA
Technical
Paper
2207**

August 1983

NASA
TP
2207
c.1

LOAN COPY: RETURN TO
AFWL TECHNICAL
KIRTLAND AFB, TX



Friction and Hardness of Gold Films Deposited by Ion Plating and Evaporation

**Kazuhisa Miyoshi,
Talivaldis Spalvins,
and Donald H. Buckley**

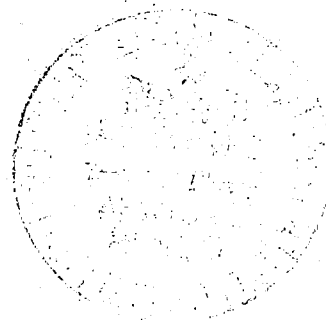

NASA



25th Anniversary
1958-1983



**NASA
Technical
Paper
2207**

1983

Friction and Hardness of Gold Films Deposited by Ion Plating and Evaporation

**Kazuhisa Miyoshi,
Talivaldis Spalvins,
and Donald H. Buckley**
*Lewis Research Center
Cleveland, Ohio*

NASA

National Aeronautics
and Space Administration

Scientific and Technical
Information Branch

1983

Summary

Sliding friction experiments and hardness measurements were conducted on an ion-plated gold film, the graded interface between film and substrate, and the substrate. Friction experiments were conducted with a 0.025-millimeter-radius spherical silicon carbide rider sliding on a coated surface in mineral oil. Various substrates were examined and included copper, iron, nickel and 440 C stainless steel. Comparative experiments were also conducted with vapor-deposited gold on these same substrates. The hardness depth profile for the ion-plated gold indicates that the hardness is influenced by the depth of the gold coating from the surface. The hardness increases with an increase in the depth. The hardness is also related to the composition gradient in the graded interface between the gold coating and the substrate. The graded interface exhibited the highest hardness as a result of an alloy hardening effect. The coefficient of friction, where the sliding action resulted in a permanent groove, is inversely related to the hardness, namely, the load carrying capacity of the metal surface. The greater the hardness that the metal surface possesses, the lower is the coefficient of friction. The graded interface between gold and nickel exhibited the lowest coefficient of friction. The coefficients of friction for ion-plated gold on various substrates correlate with the hardness of the gold and the substrate. The relationship is a linearly decreasing one. The behavior of friction and hardness for vapor-deposited gold on the various substrates is similar to that with ion-plated gold, but there is almost no graded interface between the vapor-deposited gold and the substrate.

Introduction

Most ion-plated films in aerospace mechanical components are used for tribological applications (adhesion, friction, wear and lubrication) and as protective films to increase corrosion resistance, fatigue limit, and creep resistance (refs. 1 and 2). Soft metallic films, such as silver, gold, and lead have been used very successfully as lubricants for bearings in space applications.

The excellent adherence and the high throwing power of the ion-plating process make it an extremely important technique for aircraft applications as well. It is used, for example, to coat aircraft fasteners, main landing gear cylinders, piston axle assemblies, stator vane assemblies and bulkheads.

The strong adherence of the film is attributed to the ionization of the evaporant and subsequent acceleration of the positively ionized evaporant atoms into the substrate with the formation of a graded interface between coating and substrate (refs. 3 to 5).

The basic controlling factors in ion plating are the sputter etched surface, the kinetic energy, and the amount of the ionized evaporant. The exact reaction mechanism for the interfacial formation, however, has not been established.

To understand the reaction mechanism for adhesion and interfacial formation and to improve tribological properties of thin film coatings on different substrates, it is important to know the composition and its variation in the film as well as in the interface between the film and substrate. Depth profiling is actually a very favorable technique that can be used in conjunction with any of the analytical methods, such as X-ray photoelectron spectroscopy, Auger electron spectroscopy, secondary ion mass spectroscopy, and ion scattering spectroscopy.

The present authors have conducted X-ray photoelectron spectroscopy (XPS) and depth profiling studies of ion-plated gold on nickel and iron surfaces to determine the composition profiles of the graded interfaces (ref. 6). The gold and nickel in the graded interface can form an alloy. The gold in the graded interface with iron was atomically dispersed in the iron and thus formed only a physically bonded interface.

The present investigation was conducted to examine friction and microhardness of the ion-plated gold film, the graded interface and the substrate. The various substrates examined included copper, iron, nickel and 440 C stainless steel. Sliding friction experiments were conducted with the coating, the graded interface, and the substrate in contact with a 0.025-millimeter radius spherical silicon carbide rider specimen (ref. 7) using mineral oil lubrication. Reference experiments for friction and hardness were also conducted with vapor-deposited gold on the above substrates. The surfaces were lubricated to minimize adhesion effects on friction.

Materials

Gold of 99.99 percent purity was the plating material, and the coating had a maximum thickness 0.6 micrometers. The copper substrate was 99.999 percent pure, and the nickel and iron were 99.99 percent pure.

The rider specimen that was made to slide on the coating surfaces was single-crystal silicon carbide (99.9 percent pure). The mineral oil used for lubrication was a pharmaceutical grade that had been degassed.

Apparatus

Coating

The ion plating chamber used in this study is shown in figure 1. The chamber is evacuated by a mechanical-oil

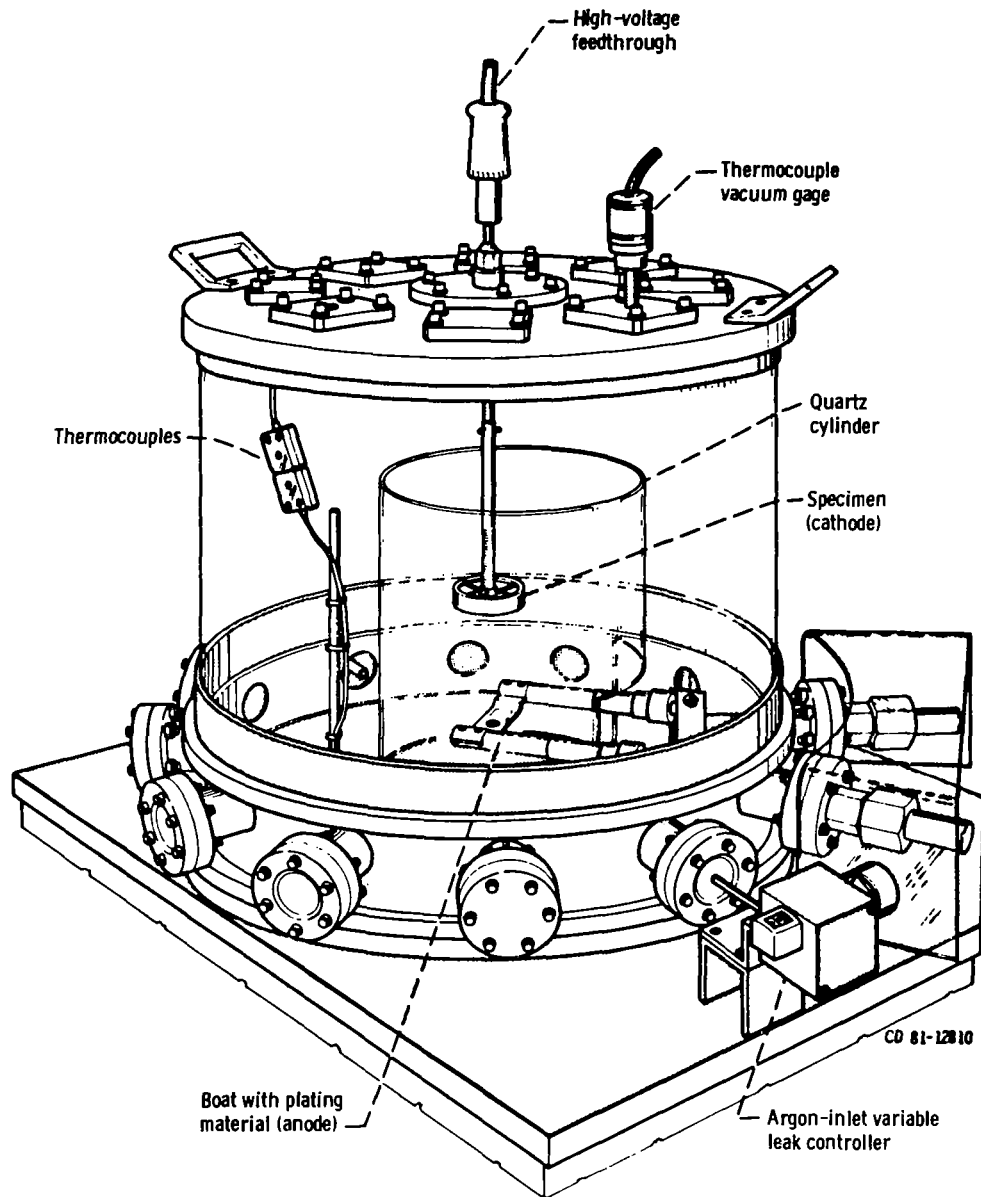

Figure 1. - Ion-plating chamber.

diffusion pumping system and a liquid-nitrogen trap. An alternative pumping system was also used to eliminate any possible external contamination, such as oil backstreaming during the pumping cycle. The mechanical and diffusion pumps were isolated from the chamber, and the pumping was performed directly by two vacsorb pumps. The chamber shown in figure 1 was also used for vapor-deposition of gold.

Friction

A friction apparatus used in this investigation is shown schematically in figure 2. It was basically a pin (rider) on a flat. The specimens were retained in a vice on a screw-

driven platform. The platform was driven through the screw by an electric motor with a gear box that allowed for changing the sliding velocity. The rider (pin) specimen was made to traverse on the surface of the flat specimen. The rider was loaded against the flat with dead weights. The arm retaining the rider contained strain gages to measure the tangential forces. The entire apparatus was housed in a plastic box.

XPS

An ultrahigh vacuum system contained an X-ray photoelectron spectroscopy analyzer and ion sputter gun. It is shown schematically in figure 3. The figure indicates

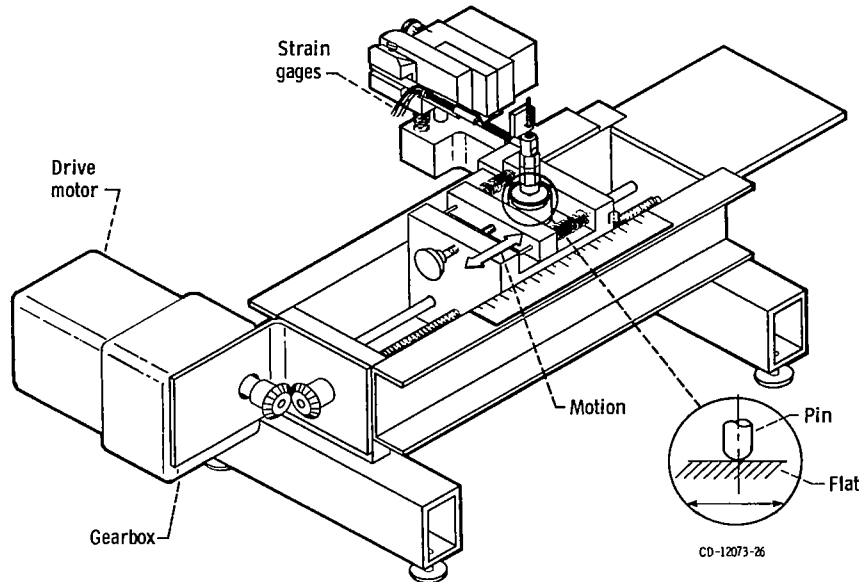

Figure 2 - Friction and wear apparatus.

the major components, including the electron energy analyzer, the X-ray source, and the ion gun used for sputter etching. The X-ray source consists of a magnesium anode. The X-ray source is located at an angle of 79° from the analyzer axis. The ion gun was located at an angle of 72° to the analyzer axis.

Experimental Procedure

Coating

The specimen to be ion-plated is the cathode of the high-voltage, direct-current circuit, and the resistance-heated tungsten evaporation boat is the anode. The plating conditions used during this study are those most commonly used in commercial ion plating. A negative potential of 3 to 5 kilovolts was applied to the specimen, with a substrate current density of 0.3 to 0.8 milliamperes per square centimeter in argon at a pressure of 2.7×10^{-1} pascal (20 millitorr). The specimen-to-boat distance was about 10 centimeters. Before evaporation, the substrates were direct-current sputter cleaned for about 10 minutes.

Before ion-plating the flat specimens were finished on 600-grit emery paper, then polished with 6-micrometer diamond powder, with 3-micrometer diamond powder, and with 1-micrometer aluminum oxide powder, respectively. The specimens were finally rinsed with acetone and absolute ethyl alcohol. For ion plating the flat specimens were mounted in a circular, stainless-steel holder (6.25 cm in diameter and 1.25 cm thick). The coating thickness ranged from 0.2 to 0.8 micrometer. The bulk temperature was monitored by a Chromel-Alumel thermocouple embedded in the holder and maintained at 125°C .

The same ion plating experimental configuration was used for the vapor deposition of gold films. Before vapor deposition the substrates were dc sputter cleaned for about 10 minutes, and subsequently the chamber pumped to a pressure of 5×10^{-6} torr where the gold evaporation was performed.

Friction

Sliding friction experiments were conducted with a 0.025-millimeter radius single crystal silicon carbide

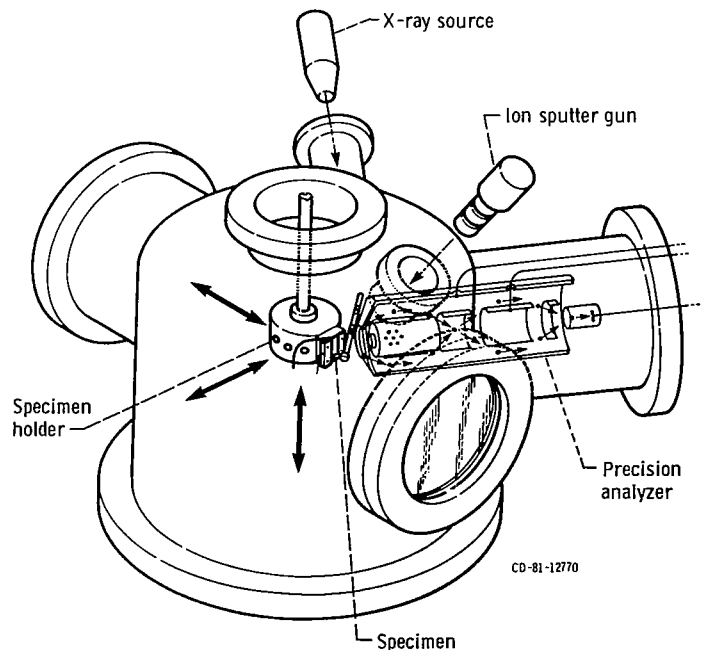

Figure 3 - Schematic representation of X-ray photoelectron spectroscopy.

spherical rider in contact with the coating in oil. The surfaces of the silicon carbide rider specimen were polished with 3-micrometer-diameter diamond powder, and then 1-micrometer-diameter aluminum oxide (Al_2O_3) powder. Both the silicon carbide and ion-plated gold surfaces were rinsed with absolute ethyl alcohol before use. The friction experiments consisted of a single pass over a total sliding distance of 3 to 10 millimeters at a sliding velocity of 0.7 millimeter per second. They were conducted in mineral oil at 25° C. The oil was used to minimize the adhesion effect.

XPS Depth Profiling

The instrument was calibrated regularly. The analyzer calibration was determined by assuming the binding energy for the Au $4f_{7/2}$ peak to be 83.8 eV. The Au $4f_{7/2}$ level was used as the reference line. All survey spectra (scans of 1000 eV) were taken at a pass energy of 50 eV. The Mg $K\alpha$ X-ray source was used with a power of 400 watts (10 kV, 40 mA). The narrow scans of such individual peaks as Au 4f and Ni 2p were obtained with a pass energy of 25 eV.

The ion-plated flat specimens were depth profiled in order to obtain the elemental composition and structure as function of depth. The ion sputtering was performed with a beam energy of 3000 eV at a beam current of 20 milliamperes with an argon pressure of 7×10^{-4} pascal for a desired sputtering time. The ion beam was continuously rastered over the specimen surface. After the sputtering, the system was re-evacuated to a pressure of 30 nanopascals or lower, and subsequently the surface was examined by XPS.

The depth in terms of a sputtering time was obtained by average measurements of ten or more surface profile records. The profilometer records made on the flat

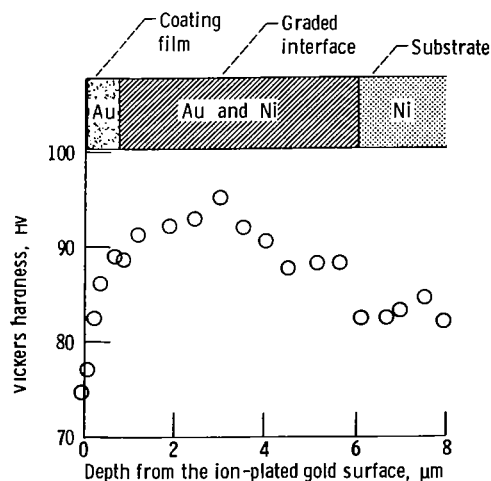

Figure 4. - Depth profiles of hardness for ion-plated gold on nickel. Thickness of gold film on nickel, 0.6 micrometer; Vickers hardness (load, 0.1 N).

specimen included the underlying area and the area in which a series of ion sputterings had been done. The depth of ion-plated gold films on substrates was also measured by a profilometer.

Hardness

The conventional microhardness (Vickers) tester used was mounted on a vibration-free table. The indentation experiments were conducted at loads of 0.1 N, 1 N, and 3 N, and at 25° C in air. The relative humidity was 40 percent. The hardness depth profiling was conducted with the ion-plated gold on nickel at a load of 0.1 N. The ion-plated gold specimen was etched by argon ion sputtering. The hardness was obtained by averaging three to five indentation measurements.

Results and Discussion

Hardness

Ion-plating. - Micro-Vickers hardness measurements were conducted in air at atmospheric pressure on the ion-plated gold deposited on nickel. Figure 4 presents the Vickers microhardness and elemental structure analyzed by XPS as a function of depth from the ion-plated gold surface. The hardness is influenced by the depth from the coating surface and is related to the composition gradient between the ion-plated gold and the substrate. The microhardness increased with increasing depth from the ion-plated gold surface. In the graded interface, the hardness increased slightly with increasing depth. The graded interface exhibited the highest hardness. Below a

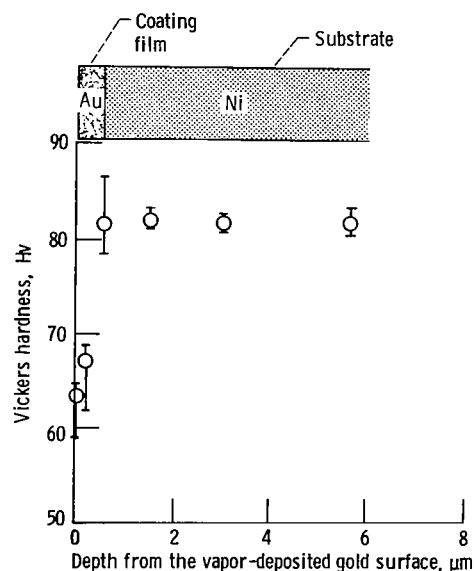
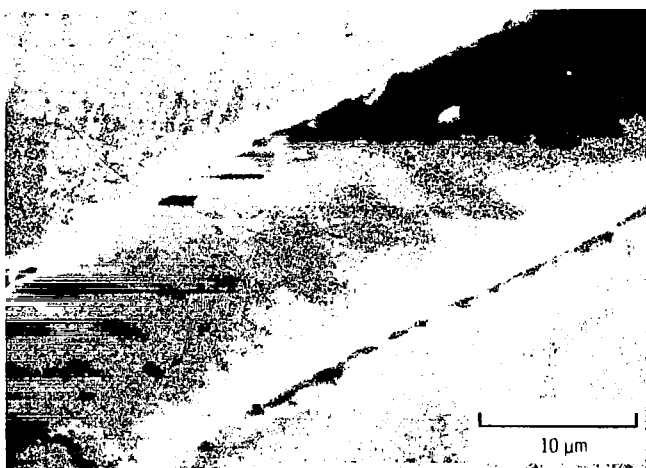

Figure 5. - Depth profiles of hardness for vapor-deposited gold on nickel. Thickness of gold film on nickel, 0.3 micrometer; Vickers hardness (load, 0.1 N).

certain depth (about 3 μm in fig. 4) in the graded interface, the hardness decreases with an increase in depth and gradually approached the hardness of the nickel substrate. The behavior of hardness in the graded interface is due to an alloy hardening effect (refs. 7 and 8).

Vapor deposition.—Figure 5 presents the microhardness and elemental structure of the vapor-deposited gold on nickel as a function of depth from the gold surface. The hardness of the gold surface was the lowest hardness value obtained. The hardness increased with an increase in the depth of the vapor-deposited gold. The hardness of the substrate, where the gold film was removed by argon ion sputtering, is almost the same as that of the bulk nickel substrate.



(a) Ion-plated gold on nickel.

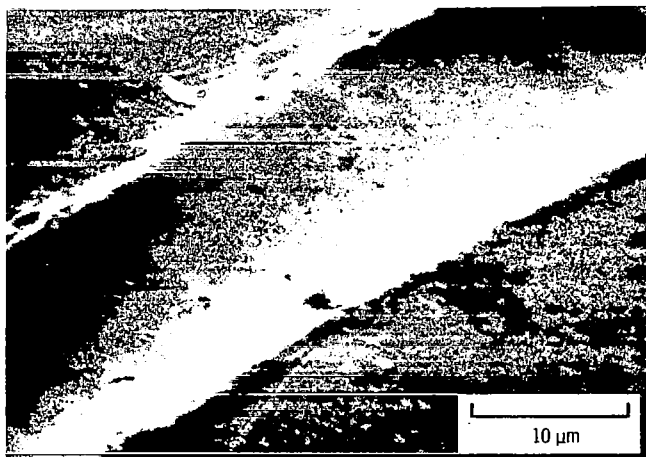

(b) Nickel substrate (6 μm etched from the ion-plated gold surface).

Figure 6. — Scanning electron micrographs of wear tracks on the ion-plated gold on nickel and on the nickel substrate. Single pass of spherical pin of radius 0.025 millimeter; mineral oil; load, 0.1 N; thickness of gold film on nickel, 0.6 micrometer.

Friction

Ion plating.—Sliding friction experiments were conducted with the ion-plated gold surface on nickel, the graded interface, and the nickel substrate in contact with a 0.025-millimeter radius spherical silicon carbide rider with a mineral oil lubricant at loads of 0.1 N and 0.05 N.

Figure 6 shows typical scanning electron micrographs of wear tracks on the ion-plated gold surface, and on the nickel substrate, from which the ion-plated gold films were removed by argon ion sputtering. Figure 6 reveals that the sliding action resulted in permanent grooves in the ion-plated gold surface and in the metal substrate, with deformed metal piled up along the sides of the groove. Under these conditions, the friction is due primarily to plowing of the ion-plated gold and the substrate, and to the shearing of adhesive bonds at the interface between the silicon carbide and the metal. The friction-force traces obtained in this investigation were characterized by randomly fluctuating behavior with no evidence of stick-slip.

Figure 7 presents the coefficients of friction for the ion-plated gold surface, the graded interface, and the nickel substrate in contact with the silicon carbide pin

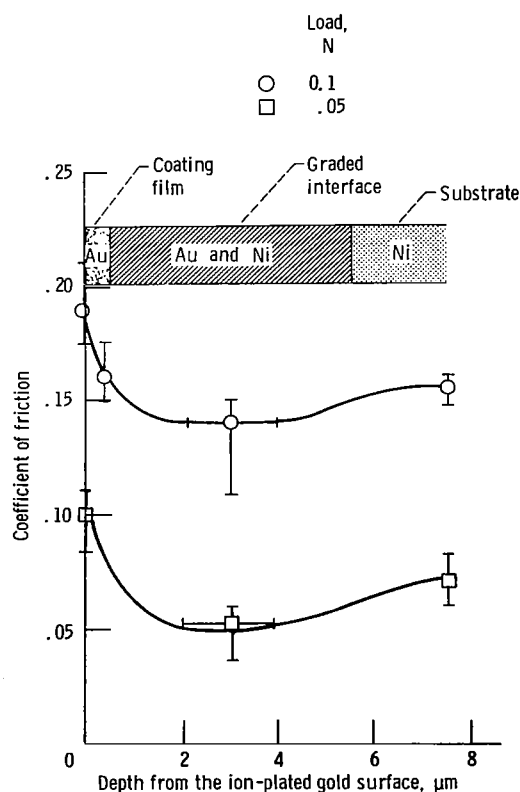
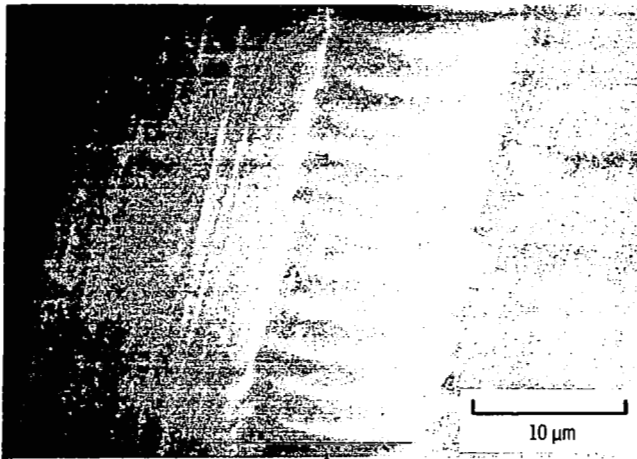

Figure 7. — Coefficient of friction as function of depth from the ion plated gold surface. 0.025-millimeter radius spherical SiC pin sliding on the ion-plated gold on nickel, the graded interface, and bulk substrate in mineral oil. Thickness of gold film on nickel, 0.6 micrometer; load, 0.1 N and 0.05 N.

(rider) lubricated with mineral oil. The coefficient of friction decreases as the depth from the gold coating surface increases. This is shown in figure 7. The graded interface resulted in the lowest coefficient of friction, as a result of an alloy hardening effect produced by the alloying of the gold with the nickel. The coefficient of friction then increases slightly with an increase in depth. The trend of the data indicate that the coefficient of friction is inversely related to the hardness, and is related to the apparent contact area of the metal. The greater the hardness the metal surface possesses, the lower is the coefficient of friction. This observation is consistent with the authors' earlier work (ref. 7).

Vapor deposition. – Sliding friction experiments were conducted with vapor-deposited films of gold on a nickel substrate in contact with a 0.025-millimeter radius



(a) Vapor-deposited gold on nickel.

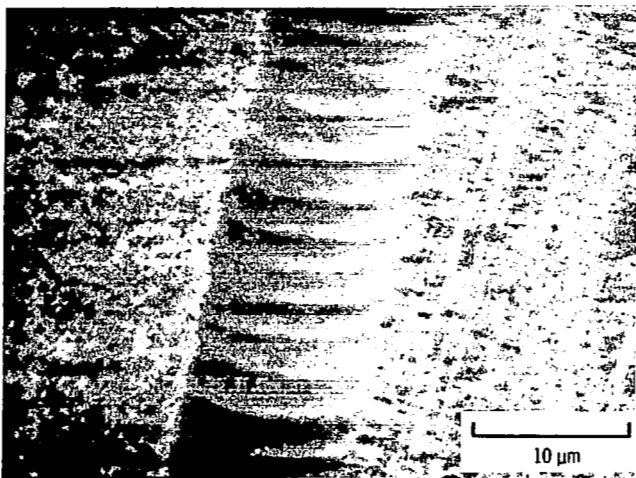

(b) Nickel substrate (3 μm etched from the vapor-deposited gold surface).

Figure 8. – Scanning electron micrographs of wear tracks on the vapor-deposited gold on nickel and the nickel substrate. Single pass of spherical pin of radius 0.025 millimeter; mineral oil; load, 0.05 N; thickness of gold film on nickel, 0.3 micrometer.

spherical silicon carbide rider lubricated with mineral oil at loads of 0.05 N and 0.1 N. Figure 8 presents typical scanning electron micrographs of wear tracks on the vapor-deposited gold surface, and on the nickel substrate, where the vapor-deposited gold film was removed by argon ion sputtering. Figure 8 reveals that the sliding action resulted in a permanent groove in the vapor-deposited gold surface and the metal substrate, with deformed metal piled up along the sides of the groove. The friction-force traces obtained in this investigation were characterized by randomly fluctuating behavior.

Figure 9 presents the coefficients of friction for vapor-deposited gold on nickel and the nickel substrate as a function of depth from the gold surface at a load of 0.1 N. The coefficient of friction is inversely related to the hardness, namely, the load-carrying capacity of the vapor-deposited gold surface and the substrate. The measured coefficients of friction and the elemental structure of the ion-plated gold on nickel indicate that there is almost no graded interface between the coating film and the substrate.

Effect of Substrate on Friction

Sliding friction experiments were conducted with ion-plated and vapor-deposited gold films on copper, nickel, and 440 C stainless steel substrates in contact with a 0.025-millimeter radius spherical silicon carbide rider with a mineral oil lubricant. The coefficients of friction are presented as a function of hardness measured at a normal load of 0.1 N in figure 10(a). The coefficients of friction also correlate with the hardness of the gold film

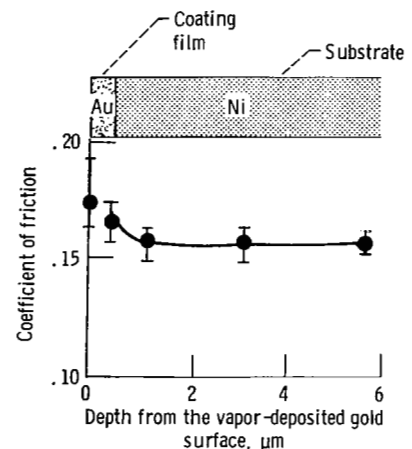

Figure 9. – Coefficient of friction as function of the depth from the vapor-deposited gold surface. 0.025 millimeter radius spherical SiC pin sliding on vapor-deposited gold on nickel and argon ion etched surface of nickel in mineral oil. Thickness of gold film on nickel, 0.3 micrometer; load, 0.1 N.

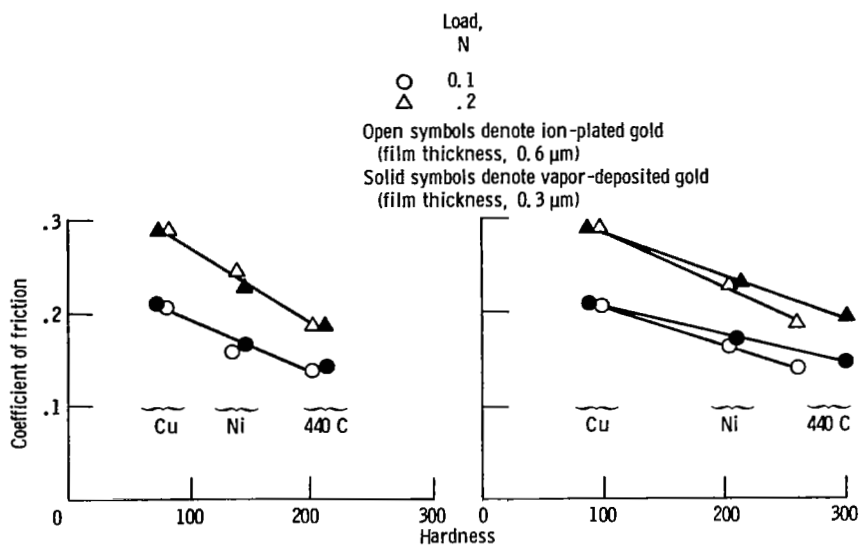

Figure 10. - Coefficients of friction for ion-plated gold and vapor-deposited gold on nickel, copper and 440 C stainless steel as function of hardness.

on the substrate, and the relationship is a linearly decreasing one. The coefficient of friction data were reexamined as a function of hardness of the substrate at loads of 1 N and 3 N. The results are presented in figure 10(b). The coefficients of friction also correlate with the hardness of the substrate itself.

Conclusions

As a result of the sliding friction experiments and Vickers microhardness measurements conducted with the ion-plated and vapor-deposited gold films on various substrates, the following conclusions are drawn:

1. The hardness depth profile for the ion-plated gold indicates that the hardness is influenced by the depth of the gold coating from the surface, and it is also related to the composition gradient between the gold and the substrate. The hardness increased with increasing depth from the ion-plated gold surface. The graded interface exhibited the highest hardness due to an alloy hardening effect.

2. The sliding action resulted in a permanent microgroove in the ion-plated gold surface, the graded interface, and in the substrate. The coefficient of friction is inversely related to the hardness, namely, the load carrying capacity of the metal surface. The greater the hardness of the metal surface, the lower the coefficient of friction. The graded interface between gold and nickel resulted in the lowest coefficient of friction due to an alloy hardening effect.

3. The coefficient of friction correlates with the

hardness of the gold, the interface and the substrate. The relationship is a linearly decrease one.

4. The behavior of friction and hardness for vapor deposited gold on various substrates is similar to that with ion-plated gold, but there is almost no graded interface between the gold and the substrate.

Lewis Research Center
 National Aeronautics and Space Administration
 Cleveland, Ohio, May 2, 1983

References

- Spalvins, T.: Sputtering and Ion Plating for Aerospace Applications. NASA TM-81726, 1981.
- Spalvins, T.: Ion Plating for the Future. NASA TM-82630, 1981.
- Johnson, R. L.: Why Ion Plating and Sputtering. Sputtering and Ion Plating, NASA SP-5111, 1972, pp. 1-9.
- Mattox, D. M.: Ion Plating—Concepts and Applications. Sputtering and Ion Plating, NASA SP-5111, 1972, pp. 11-39.
- Spalvins, T.: Characteristics of Ion Plated Films Including Mechanical Properties and Lubrication. Sputtering and Ion Plating, NASA SP-5111, 1972, pp. 41-57.
- Miyoshi, K.; Spalvins, T.; and Buckley, D. H.: Tribological Properties and X-ray Photoelectron Spectroscopy Studies of Ion-Plated Gold on Nickel and Iron. Thin Solid Films, vol. 96, 1982, pp. 9-16.
- Miyoshi, K.; and Buckley, D. H.: The Friction and Wear of Metals and Binary Alloys in Contact with an Abrasive Grit of Single-Crystal Silicon Carbide. ASLE Trans., vol. 23, no. 4, 1980, pp. 460-472.
- Stephens, J. R.; and Witzke, W. R.: Alloy Softening in Binary Iron Solid Solutions. J. Less-Common Met., vol. 48, Aug. 1976, pp. 285-308.

1. Report No. NASA TP-2207		2. Government Accession No.		3. Recipient's Catalog No.	
4. Title and Subtitle FRICTION AND HARDNESS OF GOLD FILMS DEPOSITED BY ION PLATING AND EVAPORATION				5. Report Date August 1983	
				6. Performing Organization Code 506-53-1B	
7. Author(s) Kazuhisa Miyoshi, Talivaldis Spalvins, and Donald H. Buckley				8. Performing Organization Report No. E-1528	
				10. Work Unit No.	
9. Performing Organization Name and Address National Aeronautics and Space Administration Lewis Research Center Cleveland, Ohio 44135				11. Contract or Grant No.	
				13. Type of Report and Period Covered Technical Paper	
12. Sponsoring Agency Name and Address National Aeronautics and Space Administration Washington, D.C. 20546				14. Sponsoring Agency Code	
15. Supplementary Notes					
16. Abstract <p>Sliding friction experiments were conducted with ion-plated and vapor-deposited gold films on various substrates in contact with a 0.025-mm-radius spherical silicon carbide rider in mineral oil. Hardness measurements were also made to examine the hardness depth profile of the coated gold on the substrate. The results indicate that the hardness is influenced by the depth of the gold coating from the surface. The hardness increases with an increase in the depth. The hardness is also related to the composition gradient in the graded interface between the gold coating and the substrate. The graded interface exhibited the highest hardness resulting from an alloy hardening effect. The coefficient of friction is inversely related to the hardness, namely, the load carrying capacity of the surface. The greater the hardness that the metal surface possesses, the lower is the coefficient of friction. The graded interface exhibited the lowest coefficient of friction.</p>					
17. Key Words (Suggested by Author(s)) Ion plating; Friction; Hardness; Graded interface			18. Distribution Statement Unclassified - unlimited STAR Category 26		
19. Security Classif. (of this report) Unclassified		20. Security Classif. (of this page) Unclassified		21. No. of pages 10	22. Price* A02

National Aeronautics and
Space Administration

THIRD-CLASS BULK RATE

Postage and Fees Paid
National Aeronautics and
Space Administration
NASA-451



Washington, D.C.
20546

Official Business

Penalty for Private Use, \$300

9 1 10,C, 830810 500903DS
DEPT OF THE AIR FORCE
AF WEAPONS LABORATORY
ATTN: TECHNICAL LIBRARY (SUL)
KIRTLAND AFB NM 87117

ER: If Undeliverable (Section 158
Postal Manual) Do Not Return