

NASA  
TP  
2208  
c.1**NASA  
Technical  
Paper  
2208****September 1983**

# **Simplified Method for Nonlinear Structural Analysis**

**Albert Kaufman****LOAN COPY: RETURN TO  
AFWL TECHNICAL LIBRARY  
KIRTLAND AFB, N.M. 87117****NASA****25**25th Anniversary  
1958-1983



**NASA  
Technical  
Paper  
2208**

**1983**

# **Simplified Method for Nonlinear Structural Analysis**

**Albert Kaufman**

*Lewis Research Center  
Cleveland, Ohio*

**NASA**

National Aeronautics  
and Space Administration

Scientific and Technical  
Information Branch

## Summary

Nonlinear, finite-element computer programs are too costly to use in the early design stages for hot-section components of aircraft gas turbine engines. To improve the durability of these components, it is necessary to develop simpler and more economical methods for representing the structural response of materials under cyclic loading. This study was conducted to develop a computer program for performing a simplified nonlinear structural analysis using only an elastic solution as input data.

The simplified method was based on the assumption that the inelastic regions in the structure are constrained against stress redistribution by the surrounding elastic material. Therefore the total strain history can be defined by an elastic analysis. A computer program (ANSYMP) was created to predict the stress-strain history at the critical fatigue location of a thermomechanically cycled structure from elastic input data. Appropriate material stress-strain properties and a plasticity hardening model were incorporated into the program. Effective stresses and plastic strains are approximated by an iterative and incremental solution procedure. Initial development of the simplified inelastic analysis method considered only plasticity effects. The method will be further developed to account for creep and relaxation effects.

A series of three cases were analytically examined to verify the accuracy of the simplified method. Verification was made through comparison with a three-dimensional, nonlinear, finite-element analysis (MARC). These cases were (1) a uniaxial specimen subjected to strain cycling under isothermal conditions; (2) a benchmark notch specimen subjected to load cycling; and (3) a prismatic wedge specimen subjected to thermal cycling. Monotonic stress-strain properties for IN 100 alloy and a combined isotropic-kinematic hardening model were assumed for the uniaxial and wedge specimen problems. Cyclic stress-strain properties for Inconel 718 alloy and a kinematic hardening model were used for the benchmark notch specimen problem.

Elastic and elastic-plastic finite element analyses were performed for all three cases by using the MARC computer program. The elastic solutions for the critical locations were used as input data for the simplified analysis computer program. Comparisons were made of the stress-strain histories at the critical locations as calculated from the simplified and elastic-plastic finite element analyses.

The comparisons demonstrated that the simplified method can duplicate the cyclic stress-strain hysteresis loops from the MARC nonlinear analysis to a high degree of accuracy. Mean stresses calculated from the simplified method were in generally good agreement with the MARC results. In a typical problem, ANSYMP used less

than 1 percent of the central processor unit (CPU) time required by MARC to compute the inelastic solution.

## Introduction

The drive toward better performance and fuel economy for aircraft gas turbine engines has resulted in higher turbine inlet temperatures, pressure ratios, and rotor speeds. These more severe operating conditions have subjected the hot-section components to thermomechanical load cycles that induce significant inelastic strains and eventual fatigue cracking. It has become increasingly difficult to design reliable components to meet both the engine life and performance requirements. Improvements in the durability of these components depend on accurate structural analysis and life prediction. Life prediction methods have been under development by the NASA Lewis Research Center and other organizations (refs. 1 to 4). Application of these methods requires knowledge of the temperature-stress-strain history at the critical crack initiation location of the structure.

The primary structural parameters of interest for life prediction are the total strain range and the mean cyclic stress. For most practical cases, the critical location and the total strain range can be satisfactorily obtained from an elastic analysis as demonstrated in references 3 to 9. However, in cases involving purely mechanical load cycling or large plastic strains, an elastic analysis may not be adequate to determine the total strain range. Mean stresses for hot-section components, as well as multiaxial and thermomechanical fatigue specimens, must be calculated from some type of nonlinear analysis. The accuracy of the solutions is largely dependent on the adequacy of the stress-strain properties and the plasticity model used in the analysis.

Nonlinear finite-element analysis is being increasingly used for calculating inelastic structural response. However, nonlinear methods are not feasible for use as a component design tool because of the high computing costs associated with the iterative and incremental nature of the plasticity solutions. Computing costs are further increased by the presence of high thermal gradients and geometrical irregularities, such as cooling holes, which necessitate three-dimensional analyses. Three-dimensional, nonlinear finite-element analyses are prohibitively time consuming and expensive to conduct in the early design stages for combustor and turbine structures.

To improve the design of hot-section components, it is necessary to develop simpler and more economical methods for representing structural behavior under cyclic loading. Development of life prediction methods would also benefit from a simplified analysis method for

determining the structural behavior of multiaxial and thermomechanical fatigue specimens.

Under contract to NASA Lewis, Pratt & Whitney Aircraft developed a simplified approach for approximating the stress-strain history from a linear elastic analysis (ref. 10). This method uses a conventional yield surface concept without a specific plasticity hardening model. Shifts in the stress origin due to load reversal are accounted for by assuming back stresses at various points in the loading cycle. A combined elastic-creep response was used to predict overall material behavior under cycling. Simulations of a series of Hastelloy X uniaxial experiments showed that the P&WA simplified approach gave results of similar accuracy to nonlinear finite element solutions. Since the primary aim of this contract was to develop an approach rather than a computer program, no attempt was made to automate this method.

This study was conducted to develop a fully automated simplified analytical procedure for estimating the stress-strain history of a thermomechanically cycled structure. In a different approach from that of reference 10, a simulated plasticity model was used to track the cyclic yielding. The initial development of the simplified procedure was limited to consideration of plasticity effects. Further development will consider creep and stress relaxation effects.

A computer program (ANSYMP) was created to predict the stress-strain history at the critical location of a thermomechanically cycled structure from the elastic solution. An incremental and iterative procedure estimates the plastic strains from the material stress-strain properties and the simulated plasticity hardening model. Analytical predictions from the simplified method were compared with nonlinear finite-element solutions from the MARC computer program (ref. 11) for a number of cases. These cases involved uniaxial and multiaxial stress states, isothermal and nonisothermal conditions, and various materials and plasticity hardening models. These cases included an Inconel 718 benchmark notch specimen that was load cycled in an experiment to verify structural analysis methodologies (ref. 12). Nonlinear analyses using the MARC program were performed for the benchmark problem in the study reported in reference 5. A kinematic hardening model was found to give excellent agreement with the experimental results for this problem. Another case for which the simplified method was evaluated was a double-edge wedge specimen that had been thermally cycled in fluidized beds (ref. 13). MARC nonlinear analysis results for this problem are reported in reference 6. A combined isotropic-kinematic hardening model was used for the MARC analyses because only monotonic stress-strain properties were available for the wedge specimen material.

The simplified analysis method was able to duplicate the cyclic stress-strain hysteresis loops from the nonlinear

analysis to a high degree of accuracy for most of the cases that were evaluated. Mean stresses calculated from the simplified method for the benchmark notch and wedge problems were in good agreement with results from the nonlinear analyses. For a typical problem, the simplified analysis program required less than 1 percent of the central processor unit (CPU) time required by a nonlinear finite-element program. ANSYMP is available from the Computer Software Management Information Center (COSMIC), University of Georgia, Athens, Ga. 30620.

## Analytical Procedure

A simplified inelastic procedure was developed for calculating the stress-strain history at the critical fatigue location of a structure subjected to cyclic thermal or mechanical loading. The fundamental assumption in this procedure is that the plastic region is local and is constrained from redistribution by the surrounding elastic material. It follows from this assumption that the total strain history at the critical location can be defined by an elastic solution. Justification for the assumption of elastic constraint of local inelasticity can be found in references 3 to 9, where structural analyses of combustor liners, air-cooled turbine blades, and wedge fatigue specimens have shown that the total strain ranges from elastic and nonlinear solutions are in close agreement. A corollary to this assumption is that the elastic loading and unloading segments of the effective stress-equivalent total strain hysteresis loops constructed from an elastic-plastic analysis will be parallel to the elastic hysteresis loops. This is demonstrated by comparing the nonlinear and elastic hysteresis loops in references 5 and 6.

The basic problem in developing the simplified analytical procedure was to characterize the yield surface in terms of the total strain obtained from an elastic analysis or strain measurements. Classical plasticity theory characterizes the yield surface by a yield condition to describe yielding under multiaxial stress states and by a hardening model to establish the location of the yield surface during cycling. The simplified procedure was set up to accommodate itself to any yield criterion or hardening model. The only requirements are that the elastic input data be consistent with the yield criterion and that the appropriate material properties be used in conjunction with the hardening model. Currently the simplified analysis is limited to consideration of time-independent plasticity. Future development will extend the method to creep- and time-dependent plasticity effects.

Most nonlinear computer programs use the von Mises yield criterion and deformation theory. Implicit in the von Mises yield criterion is the conversion of the total strain from a uniaxial stress-strain curve to modified equivalent total strain for multiaxial problems, as

discussed in reference 14. The modified elastic equivalent total strain corresponds to the uniaxial total elastic strain multiplied by  $2(1 + \nu)/3$ , where  $\nu$  is Poisson's ratio. This relationship must be taken into account in applying strain results from elastic finite-element programs or strain measurements as input for the simplified inelastic analysis. Both elastic and nonlinear finite-element analyses for this study were conducted with the MARC computer program. The elastic solutions computed from MARC for input into the simplified analysis method were automatically obtained in terms of von Mises effective stresses and modified equivalent total strains.

The elastic input data are subdivided into a sufficient number of increments to define the stress-strain cycle. These increments are analyzed sequentially to obtain the cumulative plastic strains and to track the yield surface. An iterative procedure is used to calculate the yield stresses for increments undergoing plastic straining. First, an estimated plastic strain is assumed for calculating an initial yield stress from the stress-strain properties and the simulated hardening model. Second, a new plastic strain is calculated as the difference between the total strain and the elastic strain component. Then the yield stress is recalculated by using the new plastic strain value. This iterative procedure is repeated until the new and previous plastic strains agree within a tolerance of 1 percent.

A Fortran IV computer program (ANSYMP) was created to automatically implement the simplified analytical procedure. The program consists of the main executive routine (ANSYMP) and two subroutines (ELAS and YIELD). The incremental elastic data and temperatures are read into subroutine ELAS. Material stress-strain properties as a function of temperature and a simulated hardening model are incorporated in subroutine YIELD.

The computer code is available from COSMIC, University of Georgia, Athens, Ga. 30602. Sample input and output data are shown in appendixes A and B, respectively. Figure 1 is a flow chart of the program.

The calculational scheme initially follows the effective stress-equivalent strain input data from subroutine ELAS until the occurrence of initial yielding. The stress-strain solution then proceeds along the yield surface as determined from the stress-strain properties in subroutine YIELD. At each increment during yielding, the stress shift (difference between new yield stress and stress predicted from elastic analysis) from the original input data is calculated. Elastic load reversal is signaled when the input stress is less than the yield stress from the previous increment. During elastic unloading, the stresses are translated from the original elastic analysis solution by the amount of the calculated stress shift. Reverse yielding occurs when the stress reaches the reverse yield surface as determined from the hardening model incorpo-

rated in subroutine YIELD. Again, the solution follows the yield surface until another load reversal is indicated when the stress based on the shifted elastic solution is less than the yield stress. The elastic response during load reversal is obtained by translating the original elastic solution according to the new stress shift calculated during reverse yielding. The stress-strain response for subsequent cycles is computed by repeating this procedure of identifying load reversals, tracking reverse yield surfaces, and translating the original elastic solution during elastic loading and unloading.

The computer program was verified by conducting simplified analyses for a series of three problems and comparing the results with those from MARC nonlinear analyses. The first of these problems was a uniaxial specimen subjected to strain cycling under isothermal conditions. Variations of this problem were run with reverse loading and strain ratcheting. A combined isotropic-kinematic hardening model was used with monotonic stress-strain properties for IN 100 alloy obtained from reference 5. Nonlinear and elastic MARC analyses of this problem were performed by using a single 20-node, three-dimensional element. The MARC solutions for the uniaxial problem were computed for the centroid of the single solid-element model. The second problem considered was a mechanically load-cycled benchmark notch specimen shown in figure 2. This specimen was tested under isothermal conditions as part of a program to provide controlled strain data for constitutive model verification (ref. 12). A MARC analysis of this problem using kinematic hardening demonstrated excellent agreement with the experimental data in reference 5. The simplified analysis of the benchmark notch problem used the kinematic model and the cyclic stress-strain data for Inconel 718 alloy given in reference 12. The third problem was an IN 100 double-edge wedge specimen that was thermally cycled in the fluidized-bed facility discussed in reference 13. This problem provides a nonisothermal case for evaluating the computer program. The simplified analysis used the combined isotropic-kinematic hardening model and the same IN 100 monotonic stress-strain properties as reported in reference 6 for direct comparison with the MARC nonlinear analysis results. The geometry of the double-edge wedge specimen is illustrated in figure 3. MARC elastic and elastic-plastic solutions for the benchmark notch and wedge specimens were computed at the closest Gaussian integration point to the critical crack initiation location.

The material properties and simulated hardening models were incorporated in subroutine YIELD. Values for the pointer KKK of 1, 2, or 3 indicate the uniaxial, benchmark notch, or wedge cases, respectively. The sample input in appendix A and output in appendix B are for the uniaxial, strain-controlled problem. The elastic

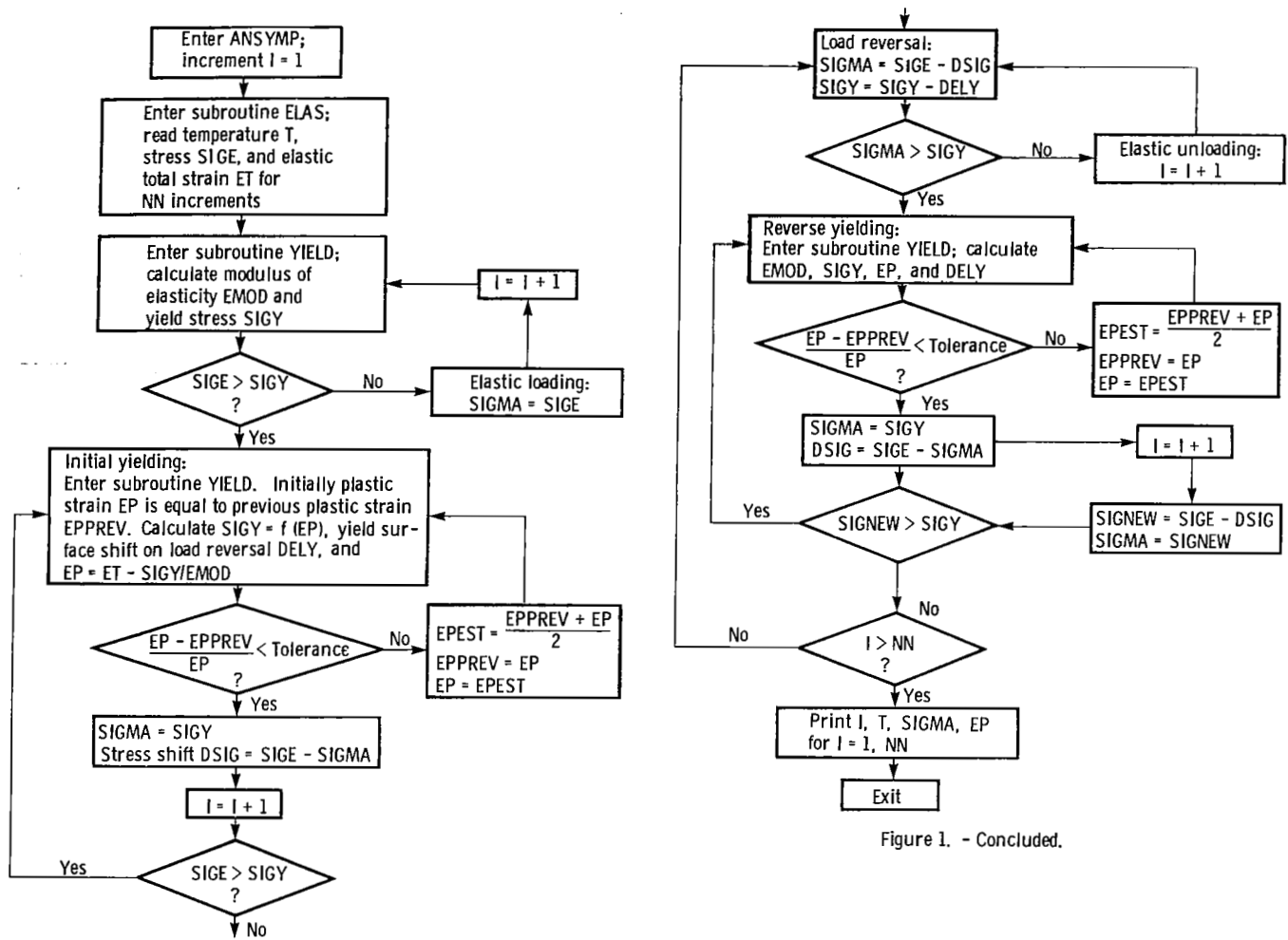

Figure 1. - Concluded.

Figure 1. - Program flow chart.

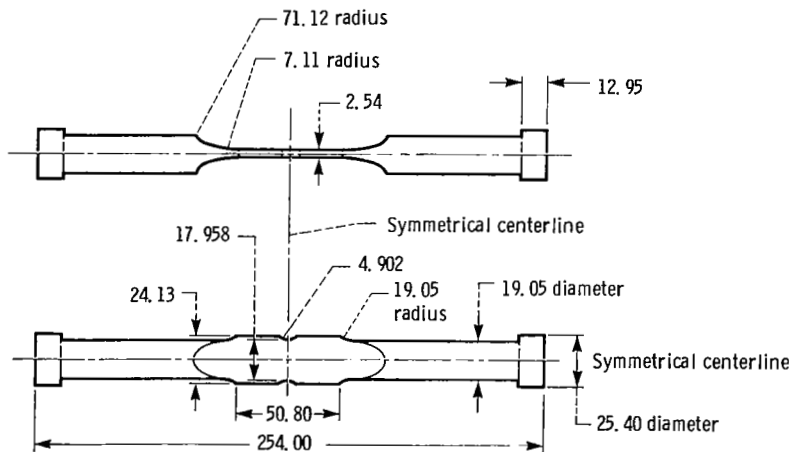

Figure 2. - Benchmark notch specimen. (Dimensions are in millimeters.)

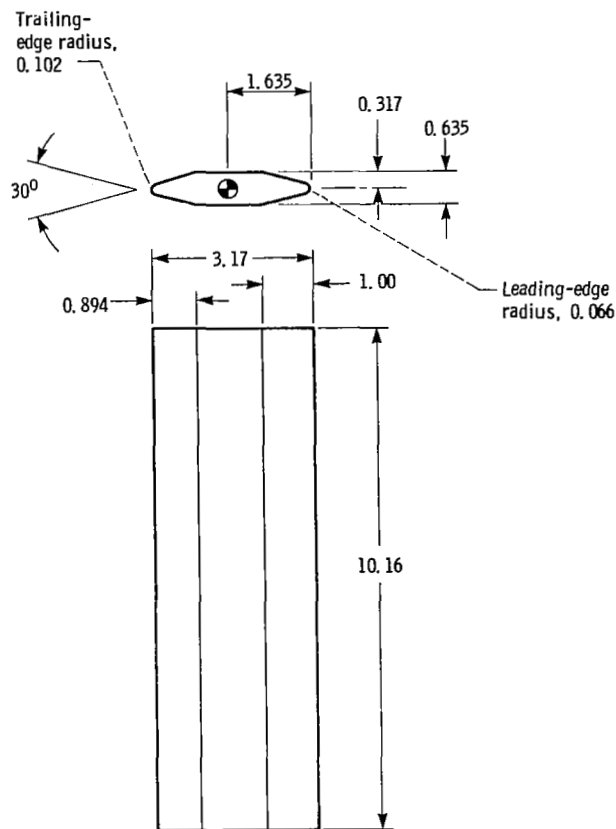

Figure 3. - Double-edge wedge. (Dimensions are in centimeters.)

input data were repeated a second time, as shown in appendix A, to conduct the simplified analyses for two cycles for all of the problems considered in this study.

## Discussion of Analytical Results

The results of the simplified elastic-plastic analyses of the uniaxial, benchmark notch, and wedge specimen cases are discussed herein. Comparisons are made with MARC elastic-plastic solutions. Stress-strain cycles used for comparison are in terms of effective stresses and equivalent total strains based on the von Mises yield criterion. The discussion is based on the critical location in the specimen where cracks would start.

### Uniaxial Problem

The uniaxial problem was used for the basic development of the simplified approach and computer program. Since the loading was strain controlled, the maximum and minimum total strains were identical for the elastic and elastic-plastic finite-element solutions. Although a combined isotropic-kinematic model was used, the peak plastic strains were large enough that the

stress-strain cycle was reduced to stabilized kinematic hardening.

Three variations of the uniaxial problem were considered: initial tensile loading, initial compressive loading, and imposed strain ratcheting. A constant temperature of 982° C was assumed during the cycles. Figure 4 shows a comparison of the stress-strain cycles obtained from the simplified and MARC elastic-plastic analyses. Agreement between the simplified and MARC elastic-plastic results was generally excellent for all of the uniaxial cases. The minor discrepancies during initial loading are due to two factors: the simplified procedure had a more gradual approach to initial yielding, and the MARC results became temporarily perturbed in the sharp transition between the elastic and work-hardening slopes.

### Benchmark Notch Problem

The rationale for the simplified approach is that strain redistribution is prevented because the local plastic region is contained by the surrounding elastic material. This assumption is most likely to be violated in a mechanically loaded structure, especially where the peak strain occurs at a discontinuity. The benchmark notch test had the major features that promote strain redistribution: testing was conducted by mechanical load cycling, the temperature was kept constant at 649° C, and the critical location was at the notch root of the specimen.

The consequences of the failure of the assumption of contained plasticity are apparent in the analytical results for the benchmark notch problem. As shown in figure 5, the total strain range from the MARC elastic-plastic analysis was about 20 percent greater than that obtained from the elastic analysis. This foreshortening of the elastic strain range caused the simplified procedure to truncate the stress-strain hysteresis loop, as shown in figure 5(a). When the elastic solution was extended to be consistent with the measured notch root strain, the agreement between the simplified and MARC elastic-plastic stress-strain hysteresis loops was excellent, as demonstrated in figure 5(b). Further study is required to develop rules or guidelines for adjusting the elastic solution in this type of problem. Both the simplified and MARC elastic-plastic analyses gave stable stress-strain hysteresis loops for the second cycle.

In terms of cycle mean stresses, the simplified procedure gave results more consistent with MARC elastic-plastic analyses than were possible from an elastic solution. Even with the unadjusted elastic solution used in figure 5(a), the mean stresses from the simplified and elastic solutions were 36 and 223 MPa, respectively, as compared with 77 MPa for the elastic-plastic solution. When the extended elastic solution shown in figure 5(b) was used, the simplified procedure had an even closer mean stress prediction of 68 MPa. The ANSYMP analy-

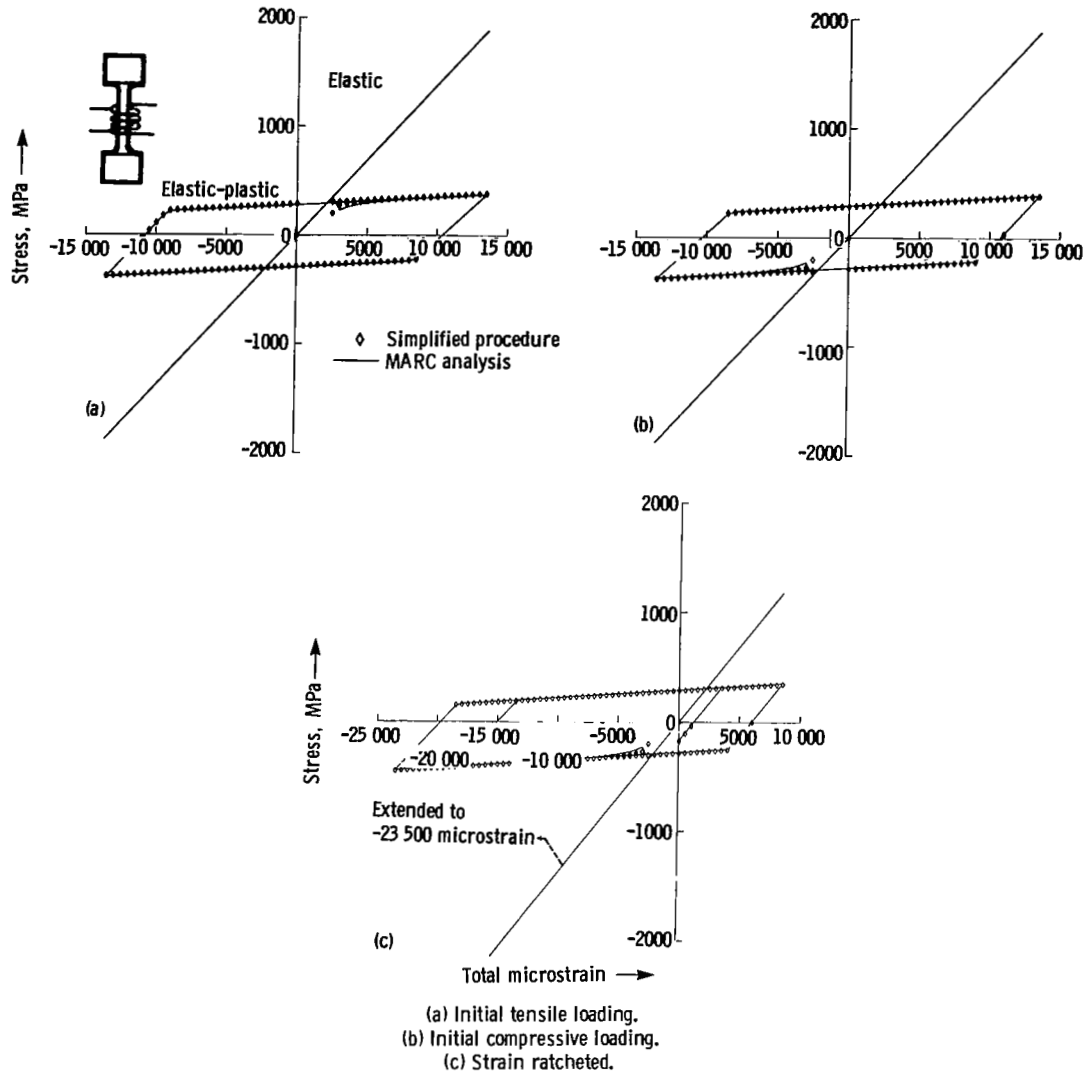

Figure 4. - Uniaxial problem.

sis of the benchmark notch problem used less than 1 percent of the CPU time required by the MARC nonlinear analysis.

### Wedge Specimen Problem

The double-edge wedge specimen provided a nonisothermal case for evaluating the simplified procedure and the operation of the ANSYMP program. Because of the incremental temperature changes, the elastic solution was no longer linear as for the isothermal uniaxial and benchmark notch cases.

In figure 6, the stress-strain hysteresis loops calculated from the simplified procedure and the MARC elastic-plastic analyses are compared for two thermal cycles. Reasonably good agreement is seen between the ANSYMP and MARC stress-strain hysteresis loops in figure 6(a). The mean stress for the second MARC stress-

strain cycle was 55 MPa. The simplified procedure predicted a mean stress of 20 MPa as contrasted with -201 MPa for the elastic solution.

It can be seen that the peak strains from the MARC elastic analyses shown in figure 6(a) are somewhat displaced in the tensile direction from the MARC elastic-plastic results. The reason for this displacement of the two MARC solutions is that there is a small initial tensile thermal stress at the first increment. This is equivalent to an initial residual stress that one would expect to be shaken out on subsequent cycling. The elastic solution was therefore displaced as shown in figure 6(b) so that the solution was at zero stress and strain at the start of the first cycle. The results from rerunning the simplified procedure using the displaced elastic solution are shown in figure 6(b). There is some improvement in the correlation between the hysteresis loops obtained from the MARC elastic-plastic and the simplified analyses.



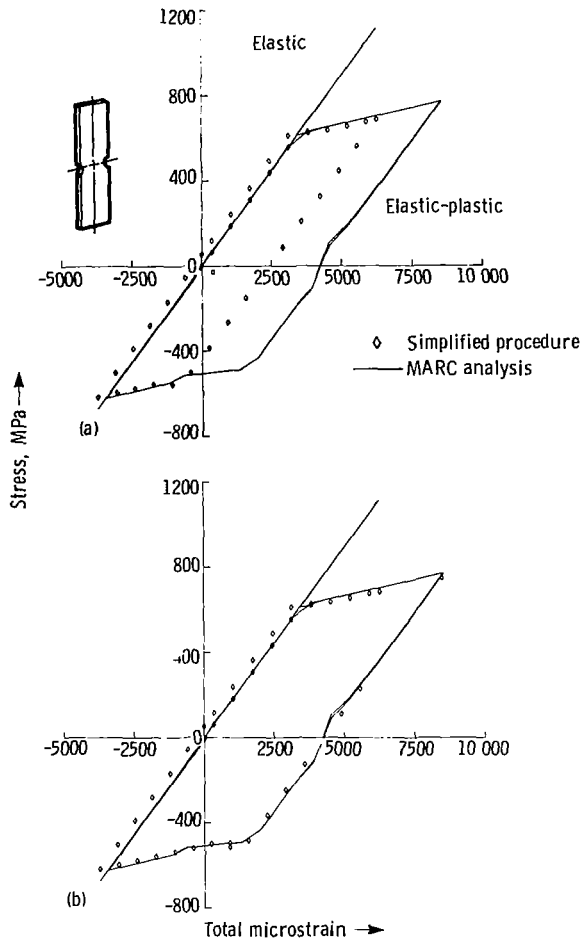

(a) Elastic solution from finite-element analysis.  
 (b) Elastic solution based on strain measurement.

Figure 5. - Benchmark notch problem.

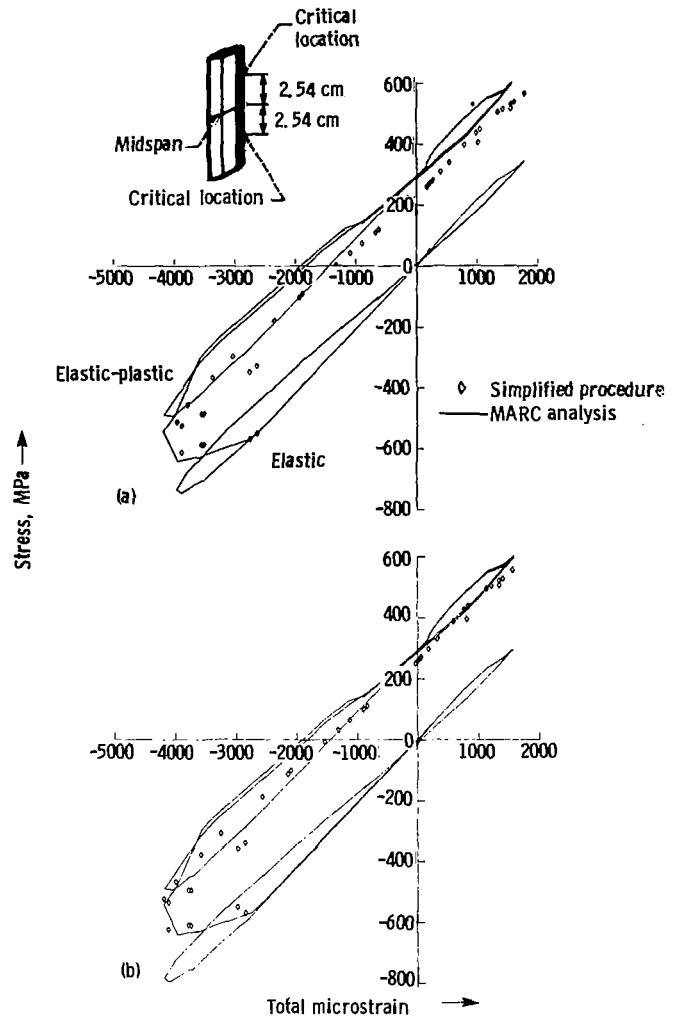

(a) Elastic solution from finite-element analysis.  
 (b) Elastic solution displaced to zero initial stress.

Figure 6. - Wedge specimen problem.

## Summary of Results

A simplified analysis procedure was developed for calculating the stress-strain history at the critical location of a thermomechanically cycled structure. A Fortran IV computer program (ANSYMP) was created to implement this procedure. The general conclusions and observations that were drawn from the evaluation of the method are as follows:

1. The predicted stress-strain response showed good to excellent agreement with nonlinear finite-element analysis results obtained by using the MARC program.

2. Mean cyclic stress predictions were in considerably better agreement with MARC nonlinear analysis results than mean stresses obtained from elastic solutions.

3. Nonlinear stress-strain histories were computed

from the ANSYMP program with less than 1 percent of the central processor unit (CPU) time required by the MARC program.

4. The main limitation of the simplified method is that strain redistribution adversely affects the solution accuracy. Strain redistribution is most likely to occur with mechanical load cycling and near geometrical discontinuities. Further study is needed to develop guidelines for adjusting the elastic input data to improve the simplified solution for this type of problem.

National Aeronautics and Space Administration  
 Lewis Research Center  
 Cleveland, Ohio, April 11, 1982

## Appendix A

### Sample Program Input

INC	TEMP F	STRESS PSI	TOTAL STRAIN				
1	1800.	0.	0.000	48	1800.	-60601.	-3.000E-03
2	1800.	50500.	2.500E-03	49	1800.	-70701.	-3.500E-03
3	1800.	60600.	3.000E-03	50	1800.	-80801.	-4.000E-03
4	1800.	70700.	3.500E-03	51	1800.	-90901.	-4.500E-03
5	1800.	80800.	4.000E-03	52	1800.	-101001.	-5.000E-03
6	1800.	90900.	4.500E-03	53	1800.	-111101.	-5.500E-03
7	1800.	101000.	5.000E-03	54	1800.	-121201.	-6.000E-03
8	1800.	111100.	5.500E-03	55	1800.	-131301.	-6.500E-03
9	1800.	121200.	6.000E-03	56	1800.	-141401.	-7.000E-03
10	1800.	131299.	6.500E-03	57	1800.	-151501.	-7.500E-03
11	1800.	141399.	7.000E-03	58	1800.	-161601.	-8.000E-03
12	1800.	151499.	7.500E-03	59	1800.	-171701.	-8.500E-03
13	1800.	161599.	8.000E-03	60	1800.	-181801.	-9.000E-03
14	1800.	171699.	8.500E-03	61	1800.	-191900.	-9.500E-03
15	1800.	181799.	9.000E-03	62	1800.	-202000.	-1.000E-02
16	1800.	191899.	9.500E-03	63	1800.	-212100.	-1.050E-02
17	1800.	201999.	1.000E-02	64	1800.	-222200.	-1.100E-02
18	1800.	212099.	1.050E-02	65	1800.	-232300.	-1.150E-02
19	1800.	222199.	1.100E-02	66	1800.	-242400.	-1.200E-02
20	1800.	232299.	1.150E-02	67	1800.	-252500.	-1.250E-02
21	1800.	242399.	1.200E-02	68	1800.	-262600.	-1.300E-02
22	1800.	252499.	1.250E-02	69	1800.	-272700.	-1.350E-02
23	1800.	262599.	1.300E-02	70	1800.	-222200.	-1.100E-02
24	1800.	272699.	1.350E-02	71	1800.	-212100.	-1.050E-02
25	1800.	171699.	8.500E-03	72	1800.	-202000.	-1.000E-02
26	1800.	161599.	8.000E-03	73	1800.	-191900.	-9.500E-03
27	1800.	151499.	7.500E-03	74	1800.	-181800.	-9.000E-03
28	1800.	141399.	7.000E-03	75	1800.	-171700.	-8.500E-03
29	1800.	131299.	6.500E-03	76	1800.	-161600.	-8.000E-03
30	1800.	121199.	6.000E-03	77	1800.	-151500.	-7.500E-03
31	1800.	111099.	5.500E-03	78	1800.	-141400.	-7.000E-03
32	1800.	100999.	5.000E-03	79	1800.	-131300.	-6.500E-03
33	1800.	90899.	4.500E-03	80	1800.	-121200.	-6.000E-03
34	1800.	80799.	4.000E-03	81	1800.	-111100.	-5.500E-03
35	1800.	70699.	3.500E-03	82	1800.	-101000.	-5.000E-03
36	1800.	60599.	3.000E-03	83	1800.	-90900.	-4.500E-03
37	1800.	50499.	2.500E-03	84	1800.	-80800.	-4.000E-03
38	1800.	40399.	2.000E-03	85	1800.	-70700.	-3.500E-03
39	1800.	30299.	1.500E-03	86	1800.	-60600.	-3.000E-03
40	1800.	20199.	9.999E-04	87	1800.	-50500.	-2.500E-03
41	1800.	10099.	4.999E-04	88	1800.	-40400.	-2.000E-03
42	1800.	-1.	-6.519E-08	89	1800.	-30300.	-1.500E-03
43	1800.	-10101.	-5.001E-04	90	1800.	-20200.	-1.000E-03
44	1800.	-20201.	-1.000E-03	91	1800.	-10100.	-5.000E-04
45	1800.	-30301.	-1.500E-03	92	1800.	0.	1.863E-09
46	1800.	-40401.	-2.000E-03	93	1800.	50500.	2.500E-03
47	1800.	-50501.	-2.500E-03	94	1800.	60600.	3.000E-03
				95	1800.	70700.	3.500E-03
				96	1800.	80800.	4.000E-03
				97	1800.	90900.	4.500E-03
				98	1800.	101000.	5.000E-03
				99	1800.	111100.	5.500E-03
				100	1800.	121200.	6.000E-03
				101	1800.	131299.	6.500E-03
				102	1800.	141399.	7.000E-03

103	1800.	151499.	7.500E-03	158	1800.	-252500.	-1.250E-02
104	1800.	161599.	8.000E-03	159	1800.	-262600.	-1.300E-02
105	1800.	171699.	8.500E-03	160	1800.	-272700.	-1.350E-02
106	1800.	181799.	9.000E-03	161	1800.	-222200.	-1.100E-02
107	1800.	191899.	9.500E-03	162	1800.	-212100.	-1.050E-02
108	1800.	201999.	1.000E-02	163	1800.	-202000.	-1.000E-02
109	1800.	212099.	1.050E-02	164	1800.	-191900.	-9.500E-03
110	1800.	222199.	1.100E-02	165	1800.	-181800.	-9.000E-03
111	1800.	232299.	1.150E-02	166	1800.	-171700.	-8.500E-03
112	1800.	242399.	1.200E-02	167	1800.	-161600.	-8.000E-03
113	1800.	252499.	1.250E-02	168	1800.	-151500.	-7.500E-03
114	1800.	262599.	1.300E-02	169	1800.	-141400.	-7.000E-03
115	1800.	272699.	1.350E-02	170	1800.	-131300.	-6.500E-03
116	1800.	171699.	8.500E-03	171	1800.	-121200.	-6.000E-03
117	1800.	161599.	8.000E-03	172	1800.	-111100.	-5.500E-03
118	1800.	151499.	7.500E-03	173	1800.	-101000.	-5.000E-03
119	1800.	141399.	7.000E-03	174	1800.	-90900.	-4.500E-03
120	1800.	131299.	6.500E-03	175	1800.	-80800.	-4.000E-03
121	1800.	121199.	6.000E-03	176	1800.	-70700.	-3.500E-03
122	1800.	111099.	5.500E-03	177	1800.	-60600.	-3.000E-03
123	1800.	100999.	5.000E-03	178	1800.	-50500.	-2.500E-03
124	1800.	90899.	4.500E-03	179	1800.	-40400.	-2.000E-03
125	1800.	80799.	4.000E-03	180	1800.	-30300.	-1.500E-03
126	1800.	70699.	3.500E-03	181	1800.	-20200.	-1.000E-03
127	1800.	60599.	3.000E-03	182	1800.	-10100.	-5.000E-04
128	1800.	50499.	2.500E-03	183	1800.	0.	1.863E-09
129	1800.	40399.	2.000E-03				
130	1800.	30299.	1.500E-03				
131	1800.	20199.	9.999E-04				
132	1800.	10099.	4.999E-04				
133	1800.	-1.	-6.519E-08				
134	1800.	-10101.	-5.001E-04				
135	1800.	-20201.	-1.000E-03				
136	1800.	-30301.	-1.500E-03				
137	1800.	-40401.	-2.000E-03				
138	1800.	-50501.	-2.500E-03				
139	1800.	-60601.	-3.000E-03				
140	1800.	-70701.	-3.500E-03				
141	1800.	-80801.	-4.000E-03				
142	1800.	-90901.	-4.500E-03				
143	1800.	-101001.	-5.000E-03				
144	1800.	-111101.	-5.500E-03				
145	1800.	-121201.	-6.000E-03				
146	1800.	-131301.	-6.500E-03				
147	1800.	-141401.	-7.000E-03				
148	1800.	-151501.	-7.500E-03				
149	1800.	-161601.	-8.000E-03				
150	1800.	-171701.	-8.500E-03				
151	1800.	-181801.	-9.000E-03				
152	1800.	-191900.	-9.500E-03				
153	1800.	-202000.	-1.000E-02				
154	1800.	-212100.	-1.050E-02				
155	1800.	-222200.	-1.100E-02				
156	1800.	-232300.	-1.150E-02				
157	1800.	-242400.	-1.200E-02				

## Appendix B

### Sample Program Output

INC	TEMP F	STRESS PSI	TOTAL STRAIN	PLASTIC STRAIN					
					48	1800.	-44587.	-0.300E-02	-0.789E-03
					49	1800.	-45099.	-0.350E-02	-0.126E-02
1	1800.	0.	0.000E+00	0.000E+00	50	1800.	-45603.	-0.400E-02	-0.173E-02
2	1800.	29252.	0.250E-02	0.000E+00	51	1800.	-46116.	-0.450E-02	-0.221E-02
3	1800.	39872.	0.300E-02	0.102E-02	52	1800.	-46628.	-0.500E-02	-0.268E-02
4	1800.	41495.	0.350E-02	0.144E-02	53	1800.	-47140.	-0.550E-02	-0.316E-02
5	1800.	43143.	0.400E-02	0.186E-02	54	1800.	-47653.	-0.600E-02	-0.363E-02
6	1800.	44353.	0.450E-02	0.229E-02	55	1800.	-48144.	-0.650E-02	-0.410E-02
7	1800.	45334.	0.500E-02	0.275E-02	56	1800.	-48656.	-0.700E-02	-0.457E-02
8	1800.	46318.	0.550E-02	0.320E-02	57	1800.	-49167.	-0.750E-02	-0.505E-02
9	1800.	47302.	0.600E-02	0.365E-02	58	1800.	-49679.	-0.800E-02	-0.552E-02
10	1800.	48189.	0.650E-02	0.410E-02	59	1800.	-50191.	-0.850E-02	-0.599E-02
11	1800.	48700.	0.700E-02	0.458E-02	60	1800.	-50702.	-0.900E-02	-0.647E-02
12	1800.	49212.	0.750E-02	0.505E-02	61	1800.	-51214.	-0.950E-02	-0.694E-02
13	1800.	49696.	0.800E-02	0.551E-02	62	1800.	-51726.	-0.100E-01	-0.742E-02
14	1800.	50208.	0.850E-02	0.599E-02	63	1800.	-52237.	-0.105E-01	-0.789E-02
15	1800.	50720.	0.900E-02	0.646E-02	64	1800.	-52749.	-0.110E-01	-0.836E-02
16	1800.	51233.	0.950E-02	0.694E-02	65	1800.	-53261.	-0.115E-01	-0.884E-02
17	1800.	51746.	0.100E-01	0.741E-02	66	1800.	-53772.	-0.120E-01	-0.931E-02
18	1800.	52259.	0.105E-01	0.789E-02	67	1800.	-54284.	-0.125E-01	-0.979E-02
19	1800.	52772.	0.110E-01	0.836E-02	68	1800.	-54796.	-0.130E-01	-0.103E-01
20	1800.	53285.	0.115E-01	0.883E-02	69	1800.	-55307.	-0.135E-01	-0.107E-01
21	1800.	53798.	0.120E-01	0.931E-02	70	1800.	-4807.	-0.110E-01	-0.107E-01
22	1800.	54311.	0.125E-01	0.978E-02	71	1800.	5293.	-0.105E-01	-0.107E-01
23	1800.	54824.	0.130E-01	0.103E-01	72	1800.	15393.	-0.100E-01	-0.107E-01
24	1800.	55337.	0.135E-01	0.107E-01	73	1800.	25493.	-0.950E-02	-0.107E-01
25	1800.	-32726.	0.850E-02	0.102E-01	74	1800.	32167.	-0.900E-02	-0.107E-01
26	1800.	-33250.	0.800E-02	0.967E-02	75	1800.	32755.	-0.850E-02	-0.102E-01
27	1800.	-33737.	0.750E-02	0.921E-02	76	1800.	33279.	-0.800E-02	-0.968E-02
28	1800.	-34282.	0.700E-02	0.872E-02	77	1800.	33766.	-0.750E-02	-0.921E-02
29	1800.	-34783.	0.650E-02	0.825E-02	78	1800.	34312.	-0.700E-02	-0.872E-02
30	1800.	-35284.	0.600E-02	0.778E-02	79	1800.	34812.	-0.650E-02	-0.825E-02
31	1800.	-35831.	0.550E-02	0.729E-02	80	1800.	35313.	-0.600E-02	-0.779E-02
32	1800.	-36339.	0.500E-02	0.682E-02	81	1800.	35861.	-0.550E-02	-0.730E-02
33	1800.	-36846.	0.450E-02	0.635E-02	82	1800.	36368.	-0.500E-02	-0.682E-02
34	1800.	-37353.	0.400E-02	0.588E-02	83	1800.	36875.	-0.450E-02	-0.635E-02
35	1800.	-37894.	0.350E-02	0.539E-02	84	1800.	37382.	-0.400E-02	-0.588E-02
36	1800.	-38405.	0.300E-02	0.492E-02	85	1800.	37924.	-0.350E-02	-0.539E-02
37	1800.	-38915.	0.250E-02	0.444E-02	86	1800.	38434.	-0.300E-02	-0.492E-02
38	1800.	-39425.	0.200E-02	0.397E-02	87	1800.	38944.	-0.250E-02	-0.445E-02
39	1800.	-39957.	0.150E-02	0.349E-02	88	1800.	39454.	-0.200E-02	-0.397E-02
40	1800.	-40469.	0.100E-02	0.301E-02	89	1800.	39986.	-0.150E-02	-0.349E-02
41	1800.	-40981.	0.500E-03	0.254E-02	90	1800.	40498.	-0.100E-02	-0.302E-02
42	1800.	-41505.	-0.652E-07	0.206E-02	91	1800.	41010.	-0.500E-03	-0.254E-02
43	1800.	-42017.	-0.500E-03	0.159E-02	92	1800.	41534.	0.186E-08	-0.206E-02
44	1800.	-42536.	-0.100E-02	0.111E-02	93	1800.	44107.	0.250E-02	0.315E-03
45	1800.	-43049.	-0.150E-02	0.634E-03	94	1800.	44616.	0.300E-02	0.788E-03
46	1800.	-43566.	-0.200E-02	0.157E-03	95	1800.	45128.	0.350E-02	0.126E-02
47	1800.	-44077.	-0.250E-02	-0.316E-03	96	1800.	45633.	0.400E-02	0.173E-02
					97	1800.	46145.	0.450E-02	0.221E-02
					98	1800.	46657.	0.500E-02	0.268E-02
					99	1800.	47170.	0.550E-02	0.316E-02
					100	1800.	47682.	0.600E-02	0.363E-02
					101	1800.	48173.	0.650E-02	0.410E-02
					102	1800.	48685.	0.700E-02	0.457E-02

103	1800.	49196.	0.750E-02	0.504E-02	158	1800.	-54284.	-0.125E-01	-0.979E-02
104	1800.	49708.	0.800E-02	0.552E-02	159	1800.	-54796.	-0.130E-01	-0.103E-01
105	1800.	50220.	0.850E-02	0.599E-02	160	1800.	-55307.	-0.135E-01	-0.107E-01
106	1800.	50731.	0.900E-02	0.647E-02	161	1800.	-4807.	-0.110E-01	-0.107E-01
107	1800.	51243.	0.950E-02	0.694E-02	162	1800.	5293.	-0.105E-01	-0.107E-01
108	1800.	51755.	0.100E-01	0.741E-02	163	1800.	15393.	-0.100E-01	-0.107E-01
109	1800.	52266.	0.105E-01	0.789E-02	164	1800.	25493.	-0.950E-02	-0.107E-01
110	1800.	52778.	0.110E-01	0.836E-02	165	1800.	32167.	-0.900E-02	-0.107E-01
111	1800.	53290.	0.115E-01	0.884E-02	166	1800.	32755.	-0.850E-02	-0.102E-01
112	1800.	53801.	0.120E-01	0.931E-02	167	1800.	33279.	-0.800E-02	-0.968E-02
113	1800.	54313.	0.125E-01	0.978E-02	168	1800.	33766.	-0.750E-02	-0.921E-02
114	1800.	54825.	0.130E-01	0.103E-01	169	1800.	34312.	-0.700E-02	-0.872E-02
115	1800.	55336.	0.135E-01	0.107E-01	170	1800.	34812.	-0.650E-02	-0.825E-02
116	1800.	-32138.	0.850E-02	0.107E-01	171	1800.	35313.	-0.600E-02	-0.779E-02
117	1800.	-33250.	0.800E-02	0.967E-02	172	1800.	35861.	-0.550E-02	-0.730E-02
118	1800.	-33737.	0.750E-02	0.921E-02	173	1800.	36368.	-0.500E-02	-0.682E-02
119	1800.	-34282.	0.700E-02	0.872E-02	174	1800.	36875.	-0.450E-02	-0.635E-02
120	1800.	-34783.	0.650E-02	0.825E-02	175	1800.	37382.	-0.400E-02	-0.588E-02
121	1800.	-35284.	0.600E-02	0.778E-02	176	1800.	37924.	-0.350E-02	-0.539E-02
122	1800.	-35831.	0.550E-02	0.729E-02	177	1800.	38434.	-0.300E-02	-0.492E-02
123	1800.	-36339.	0.500E-02	0.682E-02	178	1800.	38944.	-0.250E-02	-0.445E-02
124	1800.	-36846.	0.450E-02	0.635E-02	179	1800.	39454.	-0.200E-02	-0.397E-02
125	1800.	-37353.	0.400E-02	0.588E-02	180	1800.	39986.	-0.150E-02	-0.349E-02
126	1800.	-37894.	0.350E-02	0.539E-02	181	1800.	40498.	-0.100E-02	-0.302E-02
127	1800.	-38405.	0.300E-02	0.492E-02	182	1800.	41010.	-0.500E-03	-0.254E-02
128	1800.	-38915.	0.250E-02	0.444E-02	183	1800.	41534.	0.186E-08	-0.206E-02
129	1800.	-39425.	0.200E-02	0.397E-02					
130	1800.	-39957.	0.150E-02	0.349E-02					
131	1800.	-40469.	0.100E-02	0.301E-02					
132	1800.	-40981.	0.500E-03	0.254E-02					
133	1800.	-41505.	-0.652E-07	0.206E-02					
134	1800.	-42017.	-0.500E-03	0.159E-02					
135	1800.	-42536.	-0.100E-02	0.111E-02					
136	1800.	-43049.	-0.150E-02	0.634E-03					
137	1800.	-43566.	-0.200E-02	0.157E-03					
138	1800.	-44077.	-0.250E-02	-0.316E-03					
139	1800.	-44587.	-0.300E-02	-0.789E-03					
140	1800.	-45099.	-0.350E-02	-0.126E-02					
141	1800.	-45603.	-0.400E-02	-0.173E-02					
142	1800.	-46116.	-0.450E-02	-0.221E-02					
143	1800.	-46628.	-0.500E-02	-0.268E-02					
144	1800.	-47140.	-0.550E-02	-0.316E-02					
145	1800.	-47653.	-0.600E-02	-0.363E-02					
146	1800.	-48144.	-0.650E-02	-0.410E-02					
147	1800.	-48656.	-0.700E-02	-0.457E-02					
148	1800.	-49167.	-0.750E-02	-0.505E-02					
149	1800.	-49679.	-0.800E-02	-0.552E-02					
150	1800.	-50191.	-0.850E-02	-0.599E-02					
151	1800.	-50702.	-0.900E-02	-0.647E-02					
152	1800.	-51214.	-0.950E-02	-0.694E-02					
153	1800.	-51726.	-0.100E-01	-0.742E-02					
154	1800.	-52237.	-0.105E-01	-0.789E-02					
155	1800.	-52749.	-0.110E-01	-0.836E-02					
156	1800.	-53261.	-0.115E-01	-0.884E-02					
157	1800.	-53772.	-0.120E-01	-0.931E-02					

## References

1. Halford, G. R.; and Saltsman, J. F.: Strainrange Partitioning – A Total Strain Range Version. NASA TM-83023, 1983.
2. Hirschberg, M. H.; and Halford, G. R.: Use of Strainrange Partitioning to Predict High-Temperature Low-Cycle Fatigue Life. NASA TN D-8072, 1976.
3. Moreno, V.: Combustor Liner Durability Analysis. (PWA-5684-19, Pratt & Whitney Aircraft Group; NASA Contract NAS3-21836.) NASA CR-165250, 1981.
4. McKnight, R. L.; Lafien, J. H.; and Spamer, G. T.: Turbine Blade Tip Durability Analysis. (R81AEG372, General Electric Co.; NASA Contract NAS3-22020.) NASA CR-165268, 1981.
5. Kaufman A.: Evaluation of Inelastic Constitutive Models for Nonlinear Structural Analysis. NASA TM-82845, 1982.
6. Kaufman A.; and Hunt, L. E.: Elastic-Plastic Finite-Element Analyses of Thermally Cycled Double-Edge Wedge Specimens. NASA TP-1973, 1982.
7. Kaufman, A.; and Gaugler, R. E.: Cyclic Structural Analyses of Air-Cooled Gas Turbine Blades and Vanes. SAE Paper 760918, Nov. 1976.
8. Kaufman, A.; and Gaugler, R. E.: Nonlinear, Three-Dimensional Finite-Element Analysis of Air-Cooled Gas Turbine Blades. NASA TP-1669, 1980.
9. Kaufman, A.: Comparison of Elastic and Elastic-Plastic Structural Analyses for Cooled Turbine Blade Airfoils. NASA TP-1679, 1980.
10. Moreno, V.: Development of a Simplified Analytical Method for Representing Material Cyclic Response. (PWA-5843-13, Pratt & Whitney Aircraft Group; NASA Contract NAS3-22821.) NASA CR-168100, 1983.
11. MARC Analysis Research Corporation: User Manual – MARC General Purpose Finite Element Analysis Program. Vols. A and B, MARC Analysis Research Corporation, 1979.
12. Domas, P. A.; et al.: Benchmark Notch Test for Life Prediction. (R82AEB358, General Electric Co.; NASA Contract NAS3-22522.) NASA CR-165571, 1982.
13. Bizon, P. T.; and Spera, D. A.: Comparative Thermal Fatigue Resistances of Twenty-Six Nickel- and Cobalt-Base Alloys. NASA TN D-8071, 1975.
14. Mendelson, A.: Plasticity. Theory and Application. The Macmillan Company, 1968.

1. Report No. NASA TP-2208		2. Government Accession No.		3. Recipient's Catalog No.	
4. Title and Subtitle SIMPLIFIED METHOD FOR NONLINEAR STRUCTURAL ANALYSIS				5. Report Date September 1983	
				6. Performing Organization Code 505-33-22	
7. Author(s) Albert Kaufman				8. Performing Organization Report No. E-1646	
				10. Work Unit No.	
9. Performing Organization Name and Address National Aeronautics and Space Administration Lewis Research Center Cleveland, Ohio 44135				11. Contract or Grant No.	
				13. Type of Report and Period Covered Technical Paper	
12. Sponsoring Agency Name and Address National Aeronautics and Space Administration Washington, D.C. 20546				14. Sponsoring Agency Code	
15. Supplementary Notes Computer program ANSYMP is available from COSMIC, University of Georgia, Athens, Ga. 30602.					
16. Abstract A simplified inelastic analysis computer program was developed for predicting the stress-strain history of a thermomechanically cycled structure from an elastic solution. The program uses an iterative and incremental procedure to estimate the plastic strains from the material stress-strain properties and a simulated plasticity hardening model. The simplified method was exercised on a number of problems involving uniaxial and multiaxial loading, isothermal and nonisothermal conditions, and different materials and plasticity models. Good agreement was found between these analytical results and nonlinear finite-element solutions for these problems. The simplified analysis program used less than 1 percent of the CPU time required for a nonlinear finite-element analysis.					
17. Key Words (Suggested by Author(s)) Nonlinear structural analysis Simplified procedure			18. Distribution Statement Unclassified - unlimited STAR Category 39		
19. Security Classif. (of this report) Unclassified		20. Security Classif. (of this page) Unclassified		21. No. of pages 16	22. Price* A02