

General Disclaimer

One or more of the Following Statements may affect this Document

- This document has been reproduced from the best copy furnished by the organizational source. It is being released in the interest of making available as much information as possible.
- This document may contain data, which exceeds the sheet parameters. It was furnished in this condition by the organizational source and is the best copy available.
- This document may contain tone-on-tone or color graphs, charts and/or pictures, which have been reproduced in black and white.
- This document is paginated as submitted by the original source.
- Portions of this document are not fully legible due to the historical nature of some of the material. However, it is the best reproduction available from the original submission.

DOE/NASA/2701-2
NASA CR-168130
ATR-83(3813-08)-1ND



Phosphoric Acid Fuel Cell Platinum Use Study

(NASA-CR-168130) PHOSPHORIC ACID FUEL CELL
PLATINUM USE STUDY Final Report (Aerospace
Corp., El Segundo, Calif.) 119 p
HC 206/MF A01

N83-34452

CSSL 10A

Unclas
36102

G3/44

Herbert L. Lundblad
Government Support Operations
The Aerospace Corporation

May 1983

Prepared for
NATIONAL AERONAUTICS AND SPACE ADMINISTRATION
Lewis Research Center
Under Purchase Order C-42701-D

for

U.S. DEPARTMENT OF ENERGY
Morgantown Energy Technology Center

DOE/NASA/2701-2
NASA CR-168130
ATR-83(3813-08)-1ND

Phosphoric Acid Fuel Cell Platinum Use Study

Herbert L. Lundblad
Government Support Operations
The Aerospace Corporation
El Segundo, California

May 1983

Prepared for
National Aeronautics and Space Administration
Lewis Research Center
Cleveland, Ohio 44135
Under Purchase Order C-42701-D

for
U.S. DEPARTMENT OF ENERGY
Morgantown Energy Technology Center
Morgantown, WV 26505
Under Interagency Agreement DE-AI-21-80ET17088

FOREWORD

This report was prepared by The Aerospace Corporation under the direction and sponsorship of the National Aeronautics and Space Administration - Lewis Research Center (NASA-LeRC). The NASA-LeRC effort was funded by the Department of Energy, as part of the Phosphoric Acid Fuel Cell Program, in accordance with Interagency Agreement No. DE-AI01-80-ET-17081 dated June 30, 1980. Aerospace funding was supplied under NASA Defense Purchase Request No. C-42701 to the Air Force Space Division and processed through the Space Division (AFSC) Contract No. F04701-82-C-0083 under an interagency agreement.

PRECEDING PAGE BLANK NOT FILMED

CONTENTS

	<u>Page</u>
SUMMARY	1
1. INTRODUCTION	3
1.1 Platinum Background	4
1.2 PAFC Technology	4
1.3 The National Fuel Cell Program	6
1.4 Study Contents	6
2. PLATINUM: THE METAL AND ITS MARKET	7
2.1 Platinum-Group Metals	7
2.2 Platinum Supply Market	10
2.2.1 Platinum Resources	11
2.2.2 Platinum Reserves	12
2.2.3 Platinum Mining	13
2.2.4 Platinum Refining	15
2.2.5 World Trade of Platinum	16
2.2.6 Recycling of Platinum	21
2.2.7 Platinum Inventories and Stockpiles	24
2.2.8 Components of U.S. Platinum Supply	25
2.2.9 Platinum Supply Forecast	25
2.2.10 Substitutes for Platinum	28
2.3 Platinum Demand Market	29
2.3.1 U.S. and World Consumption	29
2.3.2 Distribution of U.S. Platinum Supply	31
2.3.3 Specific Uses of Platinum	31
2.3.4 Possible New Uses for Platinum	37
2.3.5 Platinum Demand Forecast	39
2.4 Platinum Prices	48
2.5 Platinum Market Summary	55
2.6 References	56
3. PLATINUM DEMAND OF PAFC COMMERCIALIZATION	58
3.1 PAFC Platinum Use Rates	58
3.1.1 Platinum Use Rates of Early PAFC Power Plants	59
3.1.2 Research Activities	61
3.1.3 Platinum Use Rates of Mature PAFC Power Plants	66
3.2 PAFC Market Penetration	69
3.3 Future PAFC Platinum Demand	72
3.4 Conclusions	79
3.5 References	80

PRECEDING PAGE BLANK NOT FILMED

CONTENTS (Continued)

	<u>Page</u>
4. PLATINUM MARKET ANALYSIS	81
4.1 Future Platinum Demand	81
4.2 Future Platinum Supply	85
4.3 Potential Platinum Price Changes	86
4.3.1 Market Structures	86
4.3.2 Market Behavior	91
4.3.3 Case History of Market Reaction	92
4.3.4 Correlation and Regression Analyses	93
4.4 Platinum Price Effect on Power Plant Costs	96
4.5 Vulnerability of U.S. Platinum Supply	97
4.6 Discussion of Study Findings	100
4.7 References	106
5. SUMMARY AND CONCLUSIONS	107
5.1 Platinum Market	107
5.2 PAFC Commercialization	108
5.3 Market Analysis	110
5.4 Study Conclusions	112

SUMMARY

Phosphoric acid fuel cell (PAFC) power plants use platinum catalysts in the anodes and cathodes of their fuel cell stacks. This study was conducted to evaluate the impacts that the platinum demand of PAFC power plant commercialization will have on the worldwide supply and price of platinum during 1985-2000. In specific, this study evaluates the effects of PAFC platinum demand on (1) the ability of platinum producers to meet world platinum demand, (2) the market price of platinum, and (3) the capital costs of PAFC power plants. These are issues of concern for PAFC development because inadequate platinum supplies and inflated prices could raise the capital costs of PAFC power plants and thereby hamper commercialization.

The platinum demand of PAFC commercialization is estimated by developing forecasts of platinum use per unit of generating capacity and penetration of PAFC power plants into the electric generation market. The adequacy of future platinum supplies is gauged by assessing the size of platinum reserves and the ability of platinum producers to market sufficient quantities of the reserves. The size and timing of platinum price shifts induced by the added demand of PAFC commercialization are investigated by several analytical methods. Estimates of these price shifts are then used to calculate the subsequent effects on PAFC power plant capital costs.

It was determined that the world platinum producers can market sufficient quantities of primary platinum metal to meet all demands, including the demand of PAFC commercialization, for the rest of this century and beyond. World demand for primary platinum is expected to grow at an annual rate of about 3.0 percent during 1978-2000. The platinum demand of PAFC commercialization is projected to increase world annual demand by only 2.2 to 5.7 percent during these years. Existing world reserves of platinum are large enough to last for more than 192 years at 1978 production levels and more than 116 years at projected year 2000 production levels. In the past, the platinum producers have demonstrated an ability to expand their output rapidly to meet sudden increases in demand. The moderate growth rate projected for world platinum demand and the relatively small increase that PAFC commercialization will add to this demand should not overly stress the ability of the platinum producers to keep pace with demand.

The commercialization of PAFC power plants will probably produce a 3 to 6 percent increase in the price of platinum in the first year of commercialization over the price that would be demanded in the absence of PAFC market penetration. This increase could rise to a 4 to 8 percent range with high market penetration and high platinum use rates. After these short run price impacts, however, moderate shifts in platinum demand by PAFC commercialization will likely have little effect on the price of platinum

since general economic conditions are likely to be determined more by general economic factors and precious metal speculation than by modest shifts in demand.

The projected 3 to 6 percent rise in platinum price during the first year of PAFC commercialization will raise the total initial capital costs of PAFC power plants by only 0.5 percent or less. Based on a price of \$475/tr. oz., the price of platinum would have to rise by 16.2 and 12.0 percent to cause even a 1.0 percent increase in the initial capital costs of multi-megawatt and multi-kilowatt power plants, respectively. Hence, the initial capital costs of PAFC power plants are fairly insensitive to changes in platinum price. In addition, the overall capital costs of the power plants (costs that account for the periodic replacement of the fuel cell stacks) are even less sensitive to platinum price changes than the initial capital costs.

The United States imports nearly all of its primary platinum directly or indirectly from the Republic of South Africa and thus is very vulnerable to platinum supply disruption. Although these imports have never been interrupted in the past, the potential exists in and around South Africa for political and social upheaval that could halt production for a prolonged period. A disruption of platinum imports would likely result in a major increase in platinum price until supply is resumed. However, even a doubling of the \$475/tr. oz. price would induce only relatively small power plant cost increases: 2.0 percent or less for replacement fuel cell stacks and 6.2 to 8.3 percent for initial capital costs of new PAFC power plants.

Domestic industrial platinum inventories could meet U.S. demands during an import disruption lasting a maximum of four months, but longer disruptions would have to be met by programs of platinum conservation, recycling, and substitution. Development of domestic platinum resources could fulfill a large part of domestic demand but such development would take years to complete and would likely cause significant environmental impacts. PAFC research is studying catalytic substitutes for platinum and methods to reduce platinum loading. If platinum prices ever rise high enough to seriously impact the competitiveness of PAFC power plants, platinum substitutes and reduced platinum loadings would probably be employed to soften the impact.

1. INTRODUCTION

As part of its continuing efforts to reduce United States dependence on foreign energy supplies, the U.S. Department of Energy (DOE) is promoting the private development of phosphoric acid fuel cell (PAFC) power plants for terrestrial applications. Current PAFC technology utilizes platinum catalysts in the electrodes of the fuel cell to facilitate the electrochemical reactions necessary for power production. Based on projections of platinum usage rates in PAFC power plants and projections of PAFC power plant penetration into the electric generation market, PAFC technology will apparently become a major user of platinum metal beginning in the mid to late 1980s.

This study investigates the possible repercussions that the platinum demand of PAFC commercialization will have on the worldwide supply and price of platinum from the outset of commercialization to the year 2000. This is an area of concern for PAFC power plant development because it is conceivable that inadequate platinum supplies and increased platinum demand could push the price of platinum high enough to increase significantly the overall capital costs of PAFC power plants. Higher capital costs could hamper the commercialization process. In specifics, this study addresses the following issues:

- The ability of the world platinum supply market to meet the future world demand for platinum including the demand of PAFC power plant commercialization;
- The size and timing of platinum price shifts induced by the added platinum demand of PAFC power plant commercialization; and
- The effects of the expected platinum price shifts on the overall capital costs of the PAFC power plants.

In order to evaluate the ability of the world platinum supply market to satisfy future platinum demand, including the demand of PAFC commercialization, this study reviews both the demand and supply aspects of the world platinum market. Estimates of future world platinum demand are taken from demand forecasts by the U.S. Bureau of Mines. The platinum demand of PAFC power plant commercialization is estimated by developing forecasts of both the platinum use per unit of generating capacity and the penetration of PAFC power plants into the electric generation market. The sum of the two demand estimates is then compared to the ability of the platinum supply market to meet these demands. This ability is approximated by assessing the availability of platinum reserves for extraction and the likelihood that platinum producers will be able to extract, refine, and market sufficient platinum to meet demand. The size and timing of platinum price shifts induced by the added demand of PAFC commercialization are investigated by several analytical methods. Estimates of these price shifts are then used to calculate the subsequent effects on PAFC power plant capital costs.

The need for this platinum use study was identified by the Environmental Assessment for the DOE National Fuel Cell Program. The environmental assessment indicated that the platinum demand of PAFC commercialization could stress the world platinum supply market which, in turn, could lead to the development of domestic platinum resources. The analysis of environmental impacts resulting from such development is beyond the scope of this study and is left to the environmental assessment.

The remainder of this introductory section consists of abbreviated background information on platinum, PAFC power plant technology, and the DOE PAFC Program.

1.1 PLATINUM BACKGROUND

Platinum is a precious metal with unique physical and chemical properties. It is immune to attack by most chemical reagents and resists oxidation even at high temperatures. Its electron structure confers a high degree of catalytic activity that is useful in promoting hydrogenation and oxidation reactions. Important applications for these unique properties in various industries have caused a large increase in the worldwide use of platinum during the past three decades. Platinum's appeal as jewelry and as an investment commodity has added to the growth of platinum demand and production.

Platinum is a relatively rare metal that is found in sporadic deposits around the globe. Although its worldwide reserves are large, these reserves are concentrated in a handful of foreign countries; consequently, nearly all of the newly mined platinum used in the United States is imported. The combination of platinum's importance to industry and United States reliance on platinum imports has resulted in the placement of platinum near the top of the Nation's list of strategically important minerals.

The tremendous growth in world platinum demand during the mid-1970s that was prompted by the use of platinum in automobile catalytic converters is indicative of the influence that a new source of platinum demand can exert on the platinum supply market. The sharp upswing in platinum prices of the late 1970s, followed by the recent sharp dip in platinum prices, demonstrate the price volatility of this precious metal.

1.2 PAFC TECHNOLOGY

A fuel cell is an electrochemical energy conversion device that can continuously transform the chemical energy of a fuel and oxidant directly into electrical energy. It produces useful heat as a by-product. Unlike a battery, a fuel cell does not run down or require recharging; it will operate as long as both fuel and oxidant are supplied to the electrodes and an adequate level of electrolyte is maintained. The electrodes act as catalytic reaction sites where the electrochemical transformation of fuel and oxidant occurs producing direct current electricity. Because the fuel cell is able to achieve a direct conversion of the fuel's chemical energy

into electrical energy, the Carnot cycle efficiency limitation based on the difference in temperature does not apply. The fuel cell can therefore yield a higher fuel to electrical energy conversion efficiency than conventional energy conversion devices operating at comparable temperatures.

A fuel cell consists of a positive electrode (cathode) and a negative electrode (anode) separated by an electrolyte which transmits ions but not electrons. Phosphoric acid is used as the electrolyte in PAFC power plants. Hydrogen is supplied to the anode and oxygen is supplied to the cathode. In fuel cell power plants for terrestrial use, the hydrogen is derived from hydrogen-containing fuels and air is used as the oxygen source. A platinum catalyst on the porous anode facilitates the dissociation of the hydrogen molecules in the fuel into hydrogen ions and electrons. In the acidic electrolyte, the hydrogen ions migrate through the electrolyte to the cathode and the electrons flow from the anode to the cathode through an external circuit when the electrodes are connected by an electrical conductor. Hydrogen ions, electrons, and oxygen react at the cathode to form water. This reaction is promoted by platinum catalyst on the cathode. Heat is a by-product of this process. Total platinum loading in the fuel cell is currently about 0.75 mg/cm^2 : 0.25 gm/cm^2 on the anode and 0.50 mg/cm^2 on the cathode. A single cell produces 0.5 to 1.0 volt of direct current electricity at a current that is proportional to the cell area. Individual cells are connected in series so that a fuel cell stack can be constructed with an output voltage compatible with the application.

If terrestrial fuel cell power plants are to be useful generators of electricity, they must be adaptable to the types of fuels that are economically available and produce an alternating current compatible with customer needs. Therefore, a fuel cell power plant must include not only the fuel cells that produce direct current electricity, but also a fuel processor and a power conditioner. The fuel processor converts a hydrocarbon or alcohol fuel into a hydrogen-rich gas usable by the fuel cells. The fuel processor also removes impurities in fuel that are damaging to the catalysts in the fuel cells. Because fuels have considerable variability in their chemical and heat content, the fuel processor must be tailored to the particular fuel that the power plant will be using. The power conditioner converts the direct current electricity produced by the fuel cells into alternating current electricity compatible with the utility grid and usable by utility customers. The power conditioner also regulates voltage, harmonic distortion, and other power output variables. A fourth basic power plant subsystem is thermal management. This subsystem controls the temperature of the fuel cell stack by removing waste heat produced during the fuel cell chemical reactions. This waste heat is in the form of steam and hot water and can be made available for heating, cooling, and other uses.

1.3 THE NATIONAL FUEL CELL PROGRAM

DOE is supporting the development of PAFC power plant systems through its National Fuel Cell Program. A goal of this program is to realize the potential that PAFC technology holds for reducing oil and natural gas use in the United States. This reduction of primary fuel use can be achieved in the near term by PAFC high energy efficiency and over the long term by the increased use of coal, coal-derived fuels, unconventional hydrocarbons, and alcohols in fuel cell systems capable of providing clean and efficient energy conversion and cogenerated heat at reasonable costs. The rationale underlying DOE interest in and support of PAFC technology is based upon this long term fuel use flexibility and the potential that fuel cells offer as environmentally benign and efficient conversion systems.

The National Fuel Cell Program supports development of PAFC power plants for a variety of applications. Multimegawatt power systems are under development for electric utility and large industrial applications while multikilowatt power systems are being developed for residential, commercial, and small industrial applications.

Program objectives are to develop reliable prototype PAFC power plant systems in both multimegawatt and multikilowatt power sizes that will meet national goals to conserve energy, reduce energy costs, and preserve the environment. The program seeks to achieve these objectives through support of competitive fuel cell technology development in the private sector.

Fuel cell development support is also being provided by nongovernment sources. The Electric Power Research Institute and the Gas Research Institute have programs promoting the development and demonstration of fuel cell technology. Gas and electric utilities have banded together to form fuel cell users groups that provide consultation, funding, and demonstration opportunities. These nongovernment support activities are coordinated with those of DOE to maximize development progress.

1.4 STUDY CONTENTS

This study analyzes the effects that PAFC power plant commercialization will exert on the platinum supply and price markets. The groundwork for the study is developed in Sections 2 and 3. Section 2 provides a comprehensive overview of the world and national platinum markets including supply and demand data, pricing systems, and market forecasts. Section 3 addresses the future platinum demand of PAFC commercialization. It utilizes forecasts of PAFC penetration into the electric utility market and estimations of PAFC platinum use rates to quantify the PAFC platinum demand.

The platinum market and PAFC platinum demand information of Sections 2 and 3 form the basis of the platinum market analysis of Section 4. In Section 4, the background data and forecasts are combined and examined in order to determine the effects that PAFC commercialization will have on the future supply and price of platinum. Section 5 provides a summary of the platinum market conclusions developed in Section 4.

2. PLATINUM: THE METAL AND ITS MARKET

The unique physical and chemical properties of platinum have greatly expanded the world's platinum demand during the past several decades. Platinum is being used in increasing quantities for important manufacturing, energy production, and environmental control purposes. Its use by the United States and other countries is projected to increase steadily throughout the remainder of this century. Although suppliers of platinum appear to be capable of meeting new demands, responsibility for satisfying world demand is becoming evermore concentrated on two key supplying countries--South Africa and the Soviet Union.

This section discusses the unique characteristics of platinum that have made it essential to a variety of traditional and innovative processes. Platinum resource and production figures for the United States and the world are described in detail, as are figures for platinum trade, consumption, recycling, stockpiles, and prices.

2.1 PLATINUM-GROUP METALS

The platinum group is composed of six closely related metals: platinum, palladium, rhodium, ruthenium, iridium, and osmium. The metals occur together as (1) native alloys or mineral compounds in alluvial and glacial deposits and (2) hard rock deposits where they are commonly associated with nickel and copper. They are among the scarcest of the metallic elements and are known as precious or noble metals.

The platinum-group metals (PGMs) occur in Group VIII of the periodic table in the second and third rows of the d-block elements. Figure 2-1 shows the relationship of the PGMs to neighboring elements in the periodic table. The numeral is the atomic number of the element shown.

Platinum is immune to attack by most chemical reagents and is immune to oxidation even at high temperatures. It is both malleable and ductile. Table 2-1 lists the physical properties of platinum. Reaction of platinum with oxygen, halogens, and acids is influenced, both in rate and in extent, by the state of subdivision of the metal. Some reactions that apparently do not take place with massive metal will occur with metal sponge. Platinum in colloidal form can enter into a variety of otherwise impossible reactions and also exhibits striking catalytic capabilities toward other reactions. All of the PGMs, including platinum, are susceptible to attack by the halogen elements, especially fluorine and chlorine (Ref. 2-1).*

*Applicable references are listed at the back of each section.

ORIGINAL PAGE IS
OF POOR QUALITY

<table border="1"> <tr> <td>44 Ru RUTHENIUM</td> <td>45 Rh RHODIUM</td> <td>46 Pd PALLADIUM</td> <td colspan="12"></td> </tr> <tr> <td>76 Os OSMIUM</td> <td>77 Ir IRIDIUM</td> <td>78 Pt PLATINUM</td> <td colspan="12"></td> </tr> </table>																		44 Ru RUTHENIUM	45 Rh RHODIUM	46 Pd PALLADIUM													76 Os OSMIUM	77 Ir IRIDIUM	78 Pt PLATINUM												
44 Ru RUTHENIUM	45 Rh RHODIUM	46 Pd PALLADIUM																																													
76 Os OSMIUM	77 Ir IRIDIUM	78 Pt PLATINUM																																													
H																	He																														
Li	Be															B	C	N	O	F	Ne																										
Na	Mg															Al	Si	P	S	Cl	Ar																										
K	Ca	Sc	Ti	V	Cr	Mn	Fe	Co	Ni	Cu	Zn	Ga	Ge	As	Se	Br	Kr																														
Rb	Sr	Y	Zr	Nb	Mo	Tc	PLATINUM GROUP METALS			Ag	Cd	In	Sn	Sb	Te	I	Xe																														
Cs	Ba	La	Hf	Ta	W	Re				Au	Hg	Tl	Pb	Bi	Po	At	Rn																														
Fr	Ra	Ac																																													
<table border="1"> <tr> <td>Ce</td><td>Pr</td><td>Nd</td><td>Pm</td><td>Sm</td><td>Eu</td><td>Gd</td><td>Tb</td><td>Dy</td><td>Ho</td><td>Er</td><td>Tm</td><td>Yb</td><td>Lu</td> </tr> <tr> <td>Th</td><td>Pa</td><td>U</td><td>Np</td><td>Pu</td><td>Am</td><td>Cm</td><td>Bk</td><td>Cf</td><td>Es</td><td>Fm</td><td>Md</td><td>No</td><td>Lr</td> </tr> </table>																		Ce	Pr	Nd	Pm	Sm	Eu	Gd	Tb	Dy	Ho	Er	Tm	Yb	Lu	Th	Pa	U	Np	Pu	Am	Cm	Bk	Cf	Es	Fm	Md	No	Lr		
Ce	Pr	Nd	Pm	Sm	Eu	Gd	Tb	Dy	Ho	Er	Tm	Yb	Lu																																		
Th	Pa	U	Np	Pu	Am	Cm	Bk	Cf	Es	Fm	Md	No	Lr																																		

Figure 2-1. Location of PGMs Within Periodic Table

Table 2-1. Physical Properties of Platinum

Atomic number	78
Atomic weight	195.09
Specific gravity	21.45 (20°C)
Melting point	1772°C
Boiling point	3827 + 100°C
Hardness	47 Brinell
Specific electrical resistivity	9.97 microhms/cc (20°C)
Color	Silvery-white

Nearly all of the world's platinum is derived from deposits in igneous rocks (lode deposits). It is associated with other PGMs and occurs as (1) disseminated minerals consisting of one or more elements of the group and often associated with nickel and copper sulfides and (2) native alloys, discrete minerals, and in solid solution in the lattices of other minerals (Ref. 2-1).

The relative proportions of the six PGMs vary from one lode deposit to another. Differences in the composition of the parent magmas and in the ore-forming process are responsible for this variation. The relative proportions of platinum and palladium are especially variable; for example, Canadian lode deposits contain about equal amounts of platinum and palladium, Soviet deposits contain half as much platinum as palladium, and South African deposits contain more than twice as much platinum as palladium. Platinum and palladium together almost always account for 80 to 90 weight-percent of the metals, followed in a usual order by ruthenium, rhodium, iridium, and osmium (Ref. 2-1).

PGMs are sometimes concentrated in sedimentary rock deposits upon disintegration of the host rock (placer deposits). These placer deposits are characterized by the nearly complete absence of palladium and the common presence of gold. Placer deposits of economic importance are rare and together account for about 2 percent of total world production of PGMs (Ref. 2-1).

The PGMs are infrequently found in alkalic and silicic rocks. The metals are recovered from these rock types during the final stages of copper refining, however, even though the PGM concentration in the ore is extremely low. Most of the U.S. platinum-group metal production is presently derived from copper ores mined from silicic or alkalic rocks (Ref. 2-1).

The first significant use of platinum was by the pre-Columbian Indians of Ecuador and Columbia who collected platinum nuggets from local streams and used them to make a variety of articles. Spanish conquerors named the metal platina, meaning little silver, but took little interest in the metal because of difficulty in melting and working the impure nuggets. Although platinum was the object of experimentation during the 1700s, the quality of platinum metal remained inconsistent until the early 1800s when W.H. Wollaston produced platinum products of a high quality. The other five metals of the platinum group were isolated and named between 1802 and 1844 (Ref. 2-1).

Platinumware was in common use in scientific laboratories by the end of the 1800s. The high catalytic activity of platinum was also recognized and led to platinum's use as the catalyst in the contact process for manufacturing sulfuric acid by about 1890 (Ref. 2-1).

Platinum was later used as a catalyst in the manufacture of nitric acid (prior to World War I), in the reforming of gasoline (1949), and in automobiles to control exhaust emissions (1974). Catalytic usage for the

other PGMs also became important in the production of many chemical products. The combination of chemical inertness and thermal refractoriness led to the use of PGMs in the glass, electrical, and dental alloy industries, while the intrinsic value and good workability of platinum increased its use as jewelry (Ref. 2-1).

The mining of Columbian platinum placer deposits began in 1778 and was followed by the mining of Soviet placer deposits in 1823. Production of Canadian platinum as a by-product of nickel-copper mining began in 1909. Platinum occurrences in the Bushveld Complex of South Africa were reported in 1908, but were not defined and developed until 1924. South African platinum production increased rapidly after World War II and exceeded Canadian production in 1953. Soviet placer production of platinum was augmented in the 1940s with by-product PGMs from nickel mines in northwestern Siberia and the Kola Peninsula (Ref. 2-1).

In 1957, the total world production of PGMs, including that from the Soviet Union, was estimated to be about 1.3 million troy ounces. For the next three years or so this rate of production remained reasonably steady, but thereafter increased and reached 6.2 million troy ounces in 1976 and 6.8 million troy ounces in 1980.

Exploration for PGMs in the United States declined drastically between 1900 and the mid-1960s because of the availability of foreign supplies and the lack of directly applicable modern geological, geothermal, and geophysical techniques for finding new deposits. Exploration activities increased and new domestic deposits were discovered with the development of analytical techniques for finding PGMs in geologic materials at the low parts-per-billion level and a better understanding of the geochemistry and geology of PGMs. In addition to the earlier known Goodnews Bay (Alaska) placer deposits, three other major potential PGM-producing areas were identified in the mid-1960s and 1970s: the Stillwater (Montana), Duluth (Minnesota), and Crillion-La Perouse (Alaska) Complexes. Large areas of Alaska remain unexplored for PGMs, and some areas of the conterminous United States have not been examined in detail (Ref. 2-2).

2.2 PLATINUM SUPPLY MARKET

The discussion of platinum supply describes various aspects of both the world and U.S. supply markets. Characterization of the world supply market is divided into separate descriptions of platinum resources, platinum reserves, platinum mining activities, platinum refining outputs, and world trading of platinum. The U.S. supply market is further defined by looking at domestic recycling activities, platinum inventories and stockpiles, and the contribution of all supply components to the total U.S. platinum supply. The discussion of platinum supply concludes with world platinum supply forecasts and a survey of possible platinum substitutes.

2.2.1 Platinum Resources

The classification of mineral resources is necessarily arbitrary since definitional criteria do not always coincide with natural mineral boundaries. Geologists, mining engineers, and others operating in the minerals field have used various terms to describe and classify mineral resources. In 1976, the U.S. Bureau of Mines and the U.S. Geological Survey developed a classification and nomenclature system which is now in general use.

This classification system defines a resource as:

"A concentration of naturally occurring solid, liquid, or gaseous material in or on the Earth's crust in such form and amount that economic extraction of a commodity from the concentration is currently or potentially feasible." (Ref. 2-3.)

The resource inventory is subdivided into four classes: (1) identified economic resources (reserves), (2) identified subeconomic resources, (3) undiscovered economic resources, and (4) undiscovered subeconomic resources. Identified resources can be proven or only inferred. The stocks of all resource inventories change over time as the result of exploration, technology, changes in production costs, and changes in price. Exploration locates previously undiscovered mineral deposits and thereby shifts their classification to the inventories of identified resources and reserves. This shift augments the identified resource inventories while reducing the undiscovered stock. Likewise, advances in technology and rising mineral prices can shift resources from the subeconomic inventories into the economic inventories. However, increased production costs can move deposits in the opposite direction. Mining, of course, depletes reserve inventories.

As indicated by Table 2-2, total world resources of PGMs are estimated to be 3,220 million troy ounces and are concentrated in South Africa (75 percent), the Soviet Union (12 percent), and the United States (9 percent) (Ref. 2-1).

U.S. resources of PGMs are sizable (300 million troy ounces) and are concentrated in Montana, Alaska, and Minnesota. Resources in Montana alone are estimated to be 225 million troy ounces. The platinum content of U.S. PGM resources averages about 20 percent by weight, which means that the U.S. has about 60 million troy ounces of platinum resources. The very large resources of the Republic of South Africa are located in three horizons in the Bushveld Complex in Transvaal Province. The Merensky Reef has been mined for PGMs for decades. The Upper Group Chrome horizon and the Platreef horizon are currently unmined, but several companies are conducting feasibility studies that could result in production of PGMs from them. Canadian and Soviet PGMs are virtually all by-products of nickel mining, and the resource figures of Table 2-2 are based mainly on estimates of nickel resources (Ref. 2-1).

Table 2-2. World Platinum-Group Metal Resources
(million troy ounces) (Ref. 2-1)

	Platinum Reserves	Platinum Resources ^a	Total Platinum- Group Resources
North America			
United States	NA	60	300
Canada	4	7	4
South America			
Columbia	-	4	4
Asia			
U.S.S.R	60	100	400
Africa			
Republic of South Africa	456	1128	2400
Zimbabwe	NA	41	100
World total (rounded)	520	1340	3200

^aEstimate based on platinum weight percentage of total PGM resource.

2.2.2 Platinum Reserves

A reserve is defined as the resource subset which is currently economical to extract regardless of whether the resource is proven or only inferred. The term "reserves" need not signify that extraction facilities are in place and operative, but rather indicates that the resource is considered economical to recover. The reserve is the generally accepted measure of a mineral resource since it is the quantity considered currently economically available for extraction. Its size can be modified by changes in resource size, extraction techniques, and mineral prices (Ref. 2-1).

World platinum reserves are almost entirely limited to South Africa and the Soviet Union, with a small amount of reserves in Canada. The total world PGM reserve is estimated to be 1,180 million troy ounces, of which 520 million troy ounces are platinum reserve. At current world platinum production rates (2.7 million troy ounces in 1978), this reserve will last for nearly 200 years. At projected production rates in the year 2000 (4.5 million troy ounces per year), this reserve would last about 116 years. As shown by Table 2-2, platinum reserves of 456 million troy ounces (88 percent of world total) are located in South Africa and 60 million troy ounces of platinum reserves (11 percent of world total) are located in the Soviet Union. These figures indicate the importance of these two countries to the world platinum market (Ref. 2-1).

ORIGINAL PAGE 19
OF POOR QUALITY

The United States has large PGM resources, but only about 1.0 million troy ounces of these resources are classified as reserves. Domestic reserves will increase greatly, however, if exploration and feasibility studies prove deposits in the Stillwater Complex, Montana, and Duluth Gabbro, Minnesota, to be economic and mineable.

The large South African reserves are located within the Bushveld Complex in Transvaal Province. Soviet reserves are located mainly in the Norilsk-Talnakh nickel area of northwestern Siberia, with lesser reserves at Pechenga and Monchegorsk on the Kola Peninsula. Canadian reserves are mainly at Sudbury, Ontario, and the Lynn Lake-Moak Lake region of northwestern Manitoba (Ref. 2-1).

2.2.3 Platinum Mining

Deposits of platinum-group metals are located and developed by conventional geological and mining methods. Nearly all PGMs now come from underground deposits mined by a variety of conventional methods designed for the particular ore body. These bodies can be as different as the massive sulfide emplacements of Sudbury, Canada, and the thin uniform pay zone of the Merensky Reef in South Africa. Most of the placer platinum that is mined is recovered by bucketline dredging.

South African Merensky Reef outcrops or is covered by only a thin overburden. This allows the mining of shallow ore by surface excavations and inclined shafts. Access to ore at greater depths is generally by vertical shafts. Matpacks, waste fill, and pillars provide ground support in stoping areas. Pillars remaining after mining account for about 5 percent of the stope ore. South African mines are increasingly using mechanization and modified longwall mining to increase productivity and reduce labor costs. In Canada and the Soviet Union, most sulfide, nickel-copper ore is mined underground by modified cut and fill, square set, or shrinkage stoping methods. Shafts and spiral ramps provide access to working levels (Ref. 2-2).

Nearly all of South Africa's huge production is mined from the Merensky Reef of the Bushveld Complex in Transvaal by three companies. Rustenburg Platinum Mines Ltd. (RPM) is the world's largest platinum producer and accounts for about 60 percent of South Africa's output. It is a subsidiary of Rustenburg Platinum Holding Ltd. (RPH) and operates three major mines on the western arm of the Merensky Reef. Impala Platinum Ltd., the world's second largest producer of PGMs, operates four mines near Rustenburg. Western Platinum Ltd., a smaller producer, also mines the Merensky Reef. Another small producer, ATOK Platinum Mines Ltd., mines the eastern arm of the Merensky Reef and is a subsidiary of RPH (Ref. 2-4).

INCO Ltd. operates nickel mines in Canada at Sudbury, Ontario, and at Thompson, Manitoba, from which PGMs are obtained as by-products. It is the world's third largest producer of PGMs. Falconbridge Nickel Mines Ltd., the second largest Canadian producer, produces by-product PGMs from nickel mines in Ontario and Manitoba (Ref. 2-4).

The Soviet Union publishes little information on production of PGMs and only estimates are available. Probably greater than 97 percent of its output is a by-product of nickel-copper mining, mainly at Norilsk in northwestern Siberia (Ref. 2-1).

Domestic mine production of PGMs, largely a by-product of copper mining, decreased from 7,300 troy ounces in 1979 to 3,350 troy ounces in 1980 as a result of prolonged strikes in the copper industry (Ref. 2-4). Production rebounded to an estimated 6,000 troy ounces in 1981 (Ref. 2-5). Test samples were collected at Goodnews Bay, Alaska, during 1980 and dredging operations resumed in 1981. Dredging of the placer deposit ceased in 1975 because of the low PGM content (Ref. 2-4).

Throughout the 1970s, world PGM production expanded to meet the growing world demand for platinum and the other PGMs. In South Africa, the only country to mine platinum ore as a primary ore, major expansion projects are underway, or have recently been completed, at many of its large mines. Expansion and substantial investments of capital over the years have been based upon carefully researched estimates of future world requirements, but unexpected economic trends and the 18- to 24-month lead time required to establish new capacity have made it difficult to achieve a close balance between supply and demand. During the mid-1970s, Rustenburg Platinum Mines (RPM) planned a major capital program for expansion of the Amandelbult mining section in response to anticipated automotive catalyst requirements. This program was postponed in 1977 because of lower platinum prices but was reinstated in 1978 due to higher demand and prices. RPM, the world's largest producer of platinum with an estimated production of 1.2 million troy ounces in 1979, completed the expansion of mining capacity at the Amandelbult section in 1980. RPM also finished the sinking of a new shaft at the Rustenburg section and completed construction of a second smelter in the Union section in 1980. RPM is exploring the Potgietersrust area for possible future mining operations (Ref. 2-4).

Two important characteristics of PGM deposits influence their production volumes. First, with the exception of the relatively rich material found in the Merensky Reef in South Africa and possibly the Stillwater Complex in Montana, the PGM content in ore bodies is so low as to make their recovery uneconomical except as a by-product of the production of other base metals, notably nickel and copper. Thus the production of platinum-metal concentrates in a country like Canada is tied to the production of, and hence to the market for, these base metals. In 1975 and 1979, for example, Canadian PGM production was significantly reduced largely because of a cutback in nickel mining prompted by a weak nickel demand (Ref. 2-6). Second, the ratios in which the individual metals stand to each other in mine production tend to be fairly constant in the output of each major deposit. Thus a large change in the production of one metal cannot be made without incurring a supply imbalance among the others. For example, the increased demand for rhodium for use in automobile catalytic converters has caused its price to soar. However, to double the production of rhodium to

ORIGINAL PAGE IS
OF POOR QUALITY

meet demand would require doubling the output of platinum and other PGMs and would risk oversupplying these markets. Thus the world production of platinum is tied not only to the demand for base metals such as nickel and copper, but it is also tied to the demand for the other PGMs as well.

2.2.4 Platinum Refining

The refining of the sulfide ores of Canada and the Soviet Union generates PGMs as by-products. The ores are crushed, milled, and treated by established mineral dressing techniques to produce copper-nickel concentrates that contain about 85 percent of the PGM content of the ore. These concentrates are smelted in reverberatory, blast, or electric furnaces to create the impure nickel-copper-iron matte containing the precious metals. Furnace matte is blown and fluxed in a converter to produce a low-iron, sulfur-deficient matte. Leaching and electromining methods extract the nickel and copper from the converter matte, and yield a PGM residue, slime, or sludge (Ref. 2-2).

The treatment of South African ores is different since the nickel and copper in the ore are subordinate in value to the PGMs. These ores are crushed, milled, concentrated, and then blown in converters to a high-grade nickel-copper matte containing about 40 ounces of PGMs and gold to the ton. The matte is treated to remove copper, nickel, and iron oxide. This leads to the formation of anode slimes or residues containing 25 to 75 percent PGMs (Ref. 2-1).

The methods by which PGMs are extracted from concentrates, separated, and refined are entirely chemical. Platinum and palladium are the easiest to extract. Typically, they emerge from the refinery in a few weeks at purities of 99.95 percent or higher. Recovery from concentrate is greater than 98 percent. Recovery of the other four PGMs takes longer and is considerably less efficient. Overall, about 80 percent of the PGMs content of the Sudbury, Canada, ores is recovered. Most losses occur in the ore concentration stages (Ref. 2-1).

The PGMs are usually melted in induction or vacuum-arc furnaces to prepare them for casting. Commercial articles of platinum and palladium are produced by rolling, drawing, or spinning since these two metals are ductile and easily worked. Rhodium and iridium are more difficult to work, ruthenium is still more difficult, and osmium is essentially unworkable (Ref. 2-1).

Seven or eight refineries process most of the world's primary PGMs. Rustenburg Platinum Mines' output is processed by Matthey Rustenburg Refiners Ltd., jointly owned by RPM and Johnson Matthey and Co. Ltd., of the United Kingdom. Matthey Rustenburg's refineries are located near Johannesburg and London and are operated by wholly owned subsidiary companies. Impala Platinum Ltd. has its own refinery near Johannesburg. The concentrates of Western Platinum Ltd. are converted to matte and sent to Falconbridge Nickel's refinery in Kristiansand, Norway, for separation of copper and nickel. The precious metal concentrate is returned to South Africa for refining by Lonrho Refinery Ltd. (Ref. 2-1).

Falconbridge Nickel sends nickel-copper matte from its Sudbury smelter to its electrolytic refinery in Norway and sludges bearing PGMs from this refinery are refined in Norway, the United States, and South Africa. PGM residues resulting from nickel and copper processing at the INCO refineries at Ontario, Canada, are sent to the PGM refinery of its subsidiary, Mond Nickel Co. Ltd., at Acton, England. In the Soviet Union, residues bearing PGMs from the electrolytic refinery at Norilsk and refineries in the other copper-nickel-platinum mining districts are sent to a refinery at Krasnovarsk, 900 miles south of Norilsk (Ref. 2-1).

Platinum and palladium are recovered from copper ores in the United States by U.S. Metals Refining Co. (subsidiary of AMAX Inc.) in New Jersey, ARARCO Inc., in Texas, and Kennecott Copper Corp. in Utah. Approximately 30 to 40 refiners handle or process domestic PGM scrap on a toll and nontoll basis; however, most refiners treat only platinum and palladium (Ref. 2-1). The largest processors in the United States are Engelhard Minerals and Chemical Corp., Johnson Matthey Inc., and Simmons Refining Co. (Ref. 2-4).

Impala Platinum added three additional tube mills and flotation units to its concentration facilities during 1980 and is installing added capacity to its Springs refinery to increase the company's PGM production to over 1.0 million troy ounces per year. Western Platinum announced plans in 1980 to increase capacity for PGM production from 135,000 troy ounces per year to 245,000 troy ounces per year by 1983. The company also plans to build a \$33 million project to recover an estimated 50,000 troy ounces per year from the UG-2 Reef, which underlies the Merensky Reef. The company will use a new type of recovery process that separates PGM from chromite by flotation, followed by smelting in hotter than normal furnaces to remove any remaining chromite. Matthey Rustenburg Refiners is expanding the capacity of its Waterville refinery and has announced plans to build a \$24 million PGM refinery at Royston, England. The facility, which will process both South African concentrate and secondary materials, will use solvent extraction and is scheduled for completion at the end of 1982 (Ref. 2-4). The new solvent process reduces both the number of refining stages and the time required to yield the insoluble metals. It also permits a greater use of automation (Ref. 2-7).

The Soviet Union has completed construction of new nickel and copper production facilities at Norilsk that are expected to increase the production level for PGMs, especially palladium. The smelters have a rated capacity of 550,000 metric tons per year of nickel concentrate and 650,000 metric tons per year of copper concentrate (Ref. 2-4).

2.2.5 World Trade of Platinum

The world's production of primary platinum in 1978 was 2,675,000 troy ounces. This accounted for 42 percent of the world's PGM production (Ref. 2-1). As illustrated by Figure 2-2, the majority of the world's platinum production was supplied by the Republic of South Africa (65 percent). The vast majority of world PGM production is divided nearly evenly between

ORIGINAL PAGE IS
OF POOR QUALITY

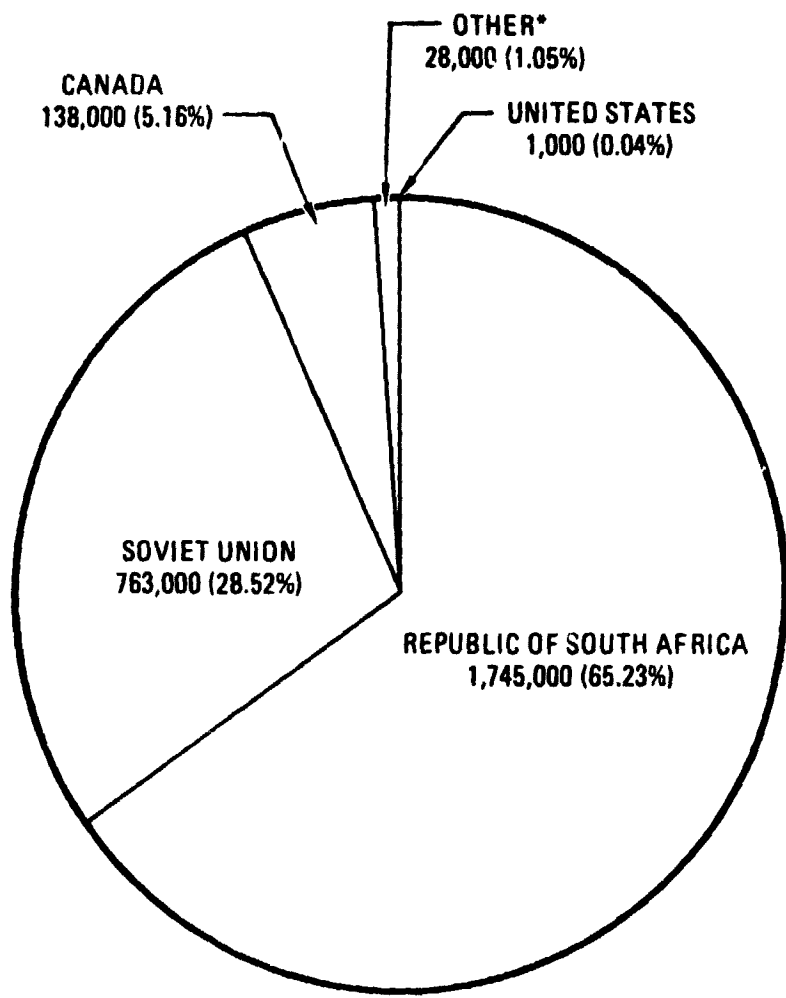

TOTAL WORLD PRODUCTION = 2,675,000 troy ounces

*INCLUDES AUSTRALIA, COLOMBIA, ETHIOPIA, FINLAND, AND YUGOSLAVIA.

Figure 2-2. World Production of Platinum in 1978
(troy ounces) (Ref. 2-1)

platinum and palladium with the other four metals of the PGM group contributing only a minor share. While U.S. platinum production has declined from 11,000 troy ounces in 1969 to only 1,000 troy ounces in 1978, world production has nearly doubled over the same period. Figure 2-3 charts the growth in world platinum production from 1969 to 1979.

All of the platinum mattes and concentrates produced in South Africa were formerly shipped to England for refining to metal. With the opening of three sizable PGM refineries in the Republic of South Africa since 1969, increasing quantities of refined metal are being shipped directly from South Africa to the consuming countries, primarily in Western Europe and North America. Most Canadian PGM concentrates are shipped to England for refining to metal. The remainder goes to Norway, where part is refined to metal and part undergoes intermediate processing and then is shipped to the United States or South Africa for refining. The Soviet Union sends a large part of its PGM exports to Japan and most of the remainder to the United States and Western Europe. The United States and Japan currently consume about two-thirds of the world's PGM production, with Western Europe and the Soviet Union dividing most of the remainder (Ref. 2-1).

The platinum output of Rustenburg Platinum Mines is marketed exclusively through Johnson Matthey. Part of Rustenburg's output is purchased by Engelhard Minerals and Chemical Corp. under a long-term sales agreement. Impala Platinum sells worldwide through Ayrton Metals Ltd. and through Platinum Sales Inc. in the United States. Western Platinum's output is sold by Falconbridge and Lonrho S.A. Ltd. INCO markets its own platinum and also sells through Engelhard in the United States and other firms in Europe. The Soviet Union sells through its trading companies and through European and New York dealers. Platinum and palladium futures are traded on the New York Mercantile Exchange. The Chicago Mercantile Exchange has a contract on platinum, but the commodity is not actively traded. In the United States, semifabricated and fabricated PGM products are produced principally by Engelhard and Matthey Bishop, a subsidiary of Johnson Matthey (Ref. 2-1).

PGMs are bought and sold in troy ounce units in most markets and in grams or kilograms where the metric system is used. Platinum and palladium are traded on the New York Mercantile Exchange in units of 50 and 100 troy ounces, respectively. On the New York Exchange, platinum metal in bar or sheet must contain at least 99.8 percent PGM with a minimum of 99.5 percent platinum (Ref. 2-1).

Metallic platinum and palladium are available in many basic forms including powder, single crystals, sponge, sheet, ribbon, foil, bars, plate, and wire. Sponge is the imperfectly consolidated metal which is the end product of chemical refining. They are also available as salts (Ref. 2-1).

The purity required for many uses of platinum has increased over the years to the point that commercial-grade platinum must now be at least 99.7 percent pure. Platinum for alloying and for laboratory utensils and

ORIGINAL PAGE 13
OF POOR QUALITY

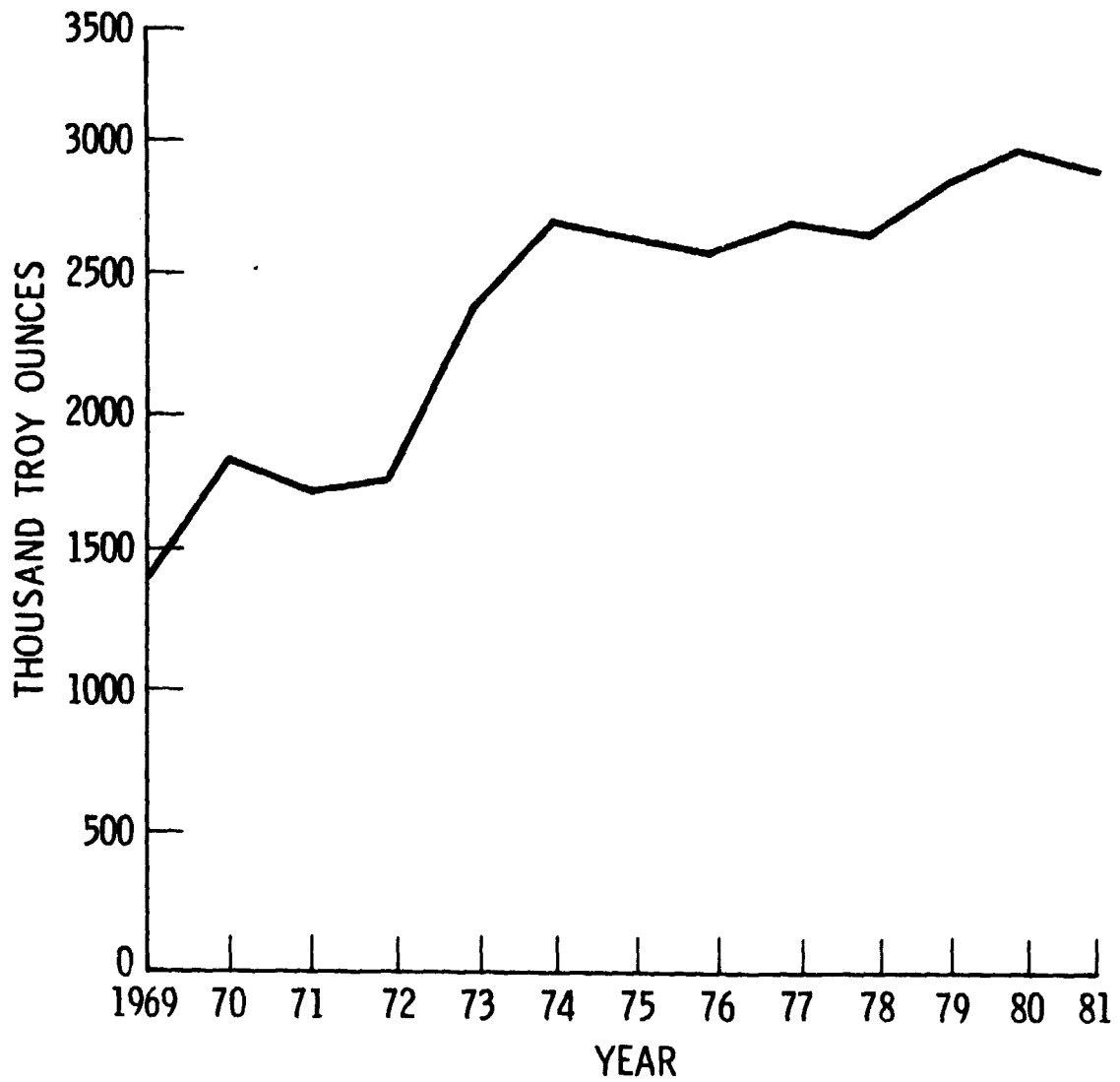

Figure 2-3. World Production of Platinum, 1969-1981
(thousand troy ounces; totals for 1980-81 are estimates) (Ref. 2-1)

electrical contacts must be at least 99.9 percent pure. Platinum at least 99.999 percent pure is considered chemically pure and is the grade required for thermocouples and resistance thermometers (Ref. 2-1).

The world production of primary platinum in 1978 was an estimated 2,675,000 troy ounces, of which the United States imported 1,258,000 troy ounces. This was about 47 percent of the world's production. These imports were in the form of platinum grains, nuggets, sponge, semimanufactured metal, scrap, and ores. Table 2-3 lists U.S. platinum imports for 1978 according to their country of origin. Platinum imported from the United Kingdom actually originated in South Africa and Canada, since the United Kingdom is not itself a PGM producer. Also, a majority of the platinum imported from "other" countries originated in Canada, South Africa, and the U.S.S.R., since the total 1978 platinum production of these other countries was only an estimated 28,000 troy ounces. Thus U.S. reliance on the three major platinum producers (Canada, South Africa, and the U.S.S.R.) is actually greater than is indicated by Table 2-3.

Table 2-3. U.S. Imports of Platinum in 1978, by Country
(troy ounces)

	<u>Grains, Nuggets</u>	<u>Sponge</u>	<u>Semimanu- factured Metal</u>	<u>Other^{a, b}</u>	<u>Estimated Total</u>
Canada	757	4,708	863	5,672	12,000
South Africa	19,314	885,562	28,535	12,589	946,000
U.S.S.R.	1,283	5,216	3,711	13,790	24,000
United Kingdom	1,975	139,713	16,487	14,825	173,000
Other ^c	<u>2,764</u>	<u>60,320</u>	<u>3,032</u>	<u>36,879</u>	<u>103,000</u>
Total	26,093	1,095,519	52,628	83,755	1,258,000

a

Derived by subtracting figures for grains and nuggets, sponge, and semimanufactured metal from the estimated total.

b

Includes platinum sweepings, waste, scrap, and ores.

c

Includes Belgium, Chile, Colombia, Italy, Japan, Luxembourg, Mexico, Netherlands, Norway, and Switzerland.

ORIGINAL PAGE 65
OF PCOR QUALITY

The United States exported 764,964 troy ounces of PGM in 1980, of which 254,495 troy ounces (33 percent) were unrolled platinum metal and 34,959 troy ounces (5 percent) were rolled platinum metal. An additional unspecified amount of platinum was exported in the form of waste, scrap, and sweepings. Total value of 1980 PGM exports was \$341 million. The principal export destinations were Japan, the United Kingdom, and West Germany (Ref. 2-4). Figure 2-4 illustrates the trends of platinum imports and exports over the 1969-1980 period.

2.2.6 Recycling of Platinum

Consumption of platinum by most industries is largely nondissipative. Platinum is virtually indestructible in normal uses, and its high cost ensures that every effort is made to conserve and recover it. The relative ease with which it can be separated from other less chemically stable materials allows nearly complete recovery.

Platinum scrap generated in manufacturing semifinished and final products is generally reprocessed for platinum recovery. Casting scrap is frequently recovered simply by adding it to melt charges. Grindings, ingot scalplings, and machining chips are generally processed through refining. Overall, there is practically no wastage of platinum in the precious-metals manufacturing industry (Ref. 2-2).

Recycling of platinum can entail remelting and refabrication of a worn metal part or coating, or complete re-refining of the constituent platinum. The consumer of the metal usually does not perform the reclaiming operation. Many industries, such as the chemical, petroleum refining, and glass industries, usually retain ownership of the platinum and pay the refiner a conversion fee. The quantity of platinum "toll-refined" in this way each year in the United States is large (533,101 troy ounces in 1980). The amounts of platinum refined from purchased scrap, called "nontoll-refined" platinum, is considerably smaller (154,075 troy ounces in 1980). The quantities of both types of secondary platinum (toll-refined and nontoll-refined) recycled in the United States from 1975 through 1980 are listed in Table 2-4. Toll-refined platinum is not considered a component of new domestic supply since its ownership does not change.

Table 2-4. Platinum Recycled in the United States, 1975-1980 (Ref. 2-4)
(troy ounces)

	<u>Toll-Refined</u>	<u>Nontoll-Refined</u>
1975	635,148	105,623
1976	494,069	64,901
1977	620,848	50,838
1978	630,961	75,585
1979	585,932	75,038
1980	533,101	154,075

ORIGINAL PAGE IS
OF POOR QUALITY

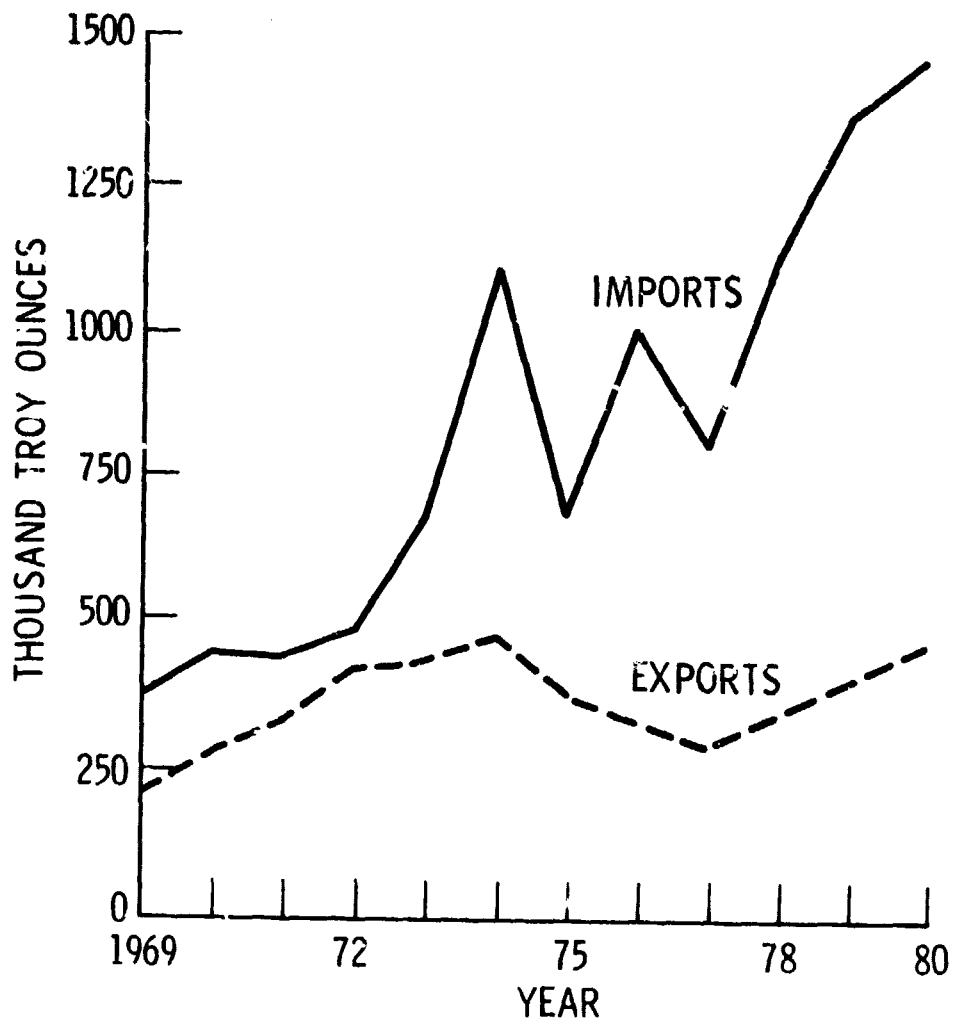

Figure 2-4. U.S. Platinum Imports and Exports, 1969-1980
(thousand troy ounces) (Ref. 2-4)

The petroleum industry efficiently recovers most of the platinum catalyst that it uses by sending the spent catalyst back to the refiner for purification and refabrication. The glass industry also recovers, with similar efficiency, most of the platinum that it uses. It is difficult to determine how much of the platinum used in the diverse chemical industry is recycled. Platinum for electrodes or electrode coatings are customarily recycled, as are platinum crucibles (Ref. 2-2).

There is little recycling in the jewelry industry apart from the reuse of machine chips and grindings resulting from jewelry fabrication. Consumption of platinum by the electrical industry is generally dissipative, and recovery of platinum from used electronic equipment is usually uneconomic even when physically possible. The platinum used in the dental and medical field, other than fabrication scrap, is for the most part not recovered (Ref. 2-2).

The catalytic converters being installed in the exhaust systems of cars and trucks are the single greatest users of platinum in the United States. This is a nondestructive use, but has been viewed as a dissipative use because of the small quantity of platinum in each converter (typically about 0.05 troy ounce). The amount of platinum loading in converters has increased with the use of three-way catalyst systems, and the accumulating quantities of platinum, palladium, and rhodium carried by converters represent an increasing aboveground resource of all three metals (Ref. 2-2).

Processes for the recovery of precious metals from catalytic converters have been developed, but only small amounts have been recovered from this source, primarily because of economic and logistics problems. Automobile and canister manufacturers do recover inhouse scrap; but once the catalyst is mounted on autos, it has not been regarded as an item for recovery. The size of this potential aboveground platinum resource is a function of factors such as catalyst loading, auto scrapage rates, and the percentage of platinum recoverable from a used converter. Utilizing the resource requires proper economic incentives and the establishment of a specialized infrastructure for collecting and processing the used converters. It is estimated that if catalytic converters were reprocessed on a large scale, more than 200,000 ounces of PGMs could be recovered from this source annually, beginning in the early 1980s (Ref. 2-1). A second study indicates that depending on catalyst loading, scrapage rates, and refining recovery, PGM recovery from catalytic converters could range as high as 1,200,000 troy ounces annually, but would more likely be about 600,000 troy ounces annually. Approximately half of this total would be platinum (Ref. 2-2). It is becoming increasingly evident that the rising price of platinum and the growing platinum resource in catalytic converters will eventually stimulate the large-scale utilization of this resource. This recovery could account for a significant percentage of platinum required by new catalytic converters in the future.

2.2.7 Platinum Inventories and Stockpiles

Stocks of platinum metal are held in reserve in private inventories and government stockpiles. These stocks represent an important domestic platinum resource. While the size of private inventories fluctuates constantly in response to market conditions, the size of government stockpiles is nearly static. Government stockpiles are held off the market until needed during a national supply emergency.

Private inventories are held by the New York Mercantile Exchange, refiners, importers, and dealers. The size of these inventories is a function of platinum supply, demand, and price, and has fluctuated from year to year. Private stocks of inventories increased sharply during 1980 as a result of a substantial increase in inventories held by the New York Mercantile Exchange. Private stocks at the end of 1980 amounted to 502,185 troy ounces of platinum. Over recent years, private inventories have exceeded the equivalent of four months of domestic platinum consumption. Private inventories are actually greater than these figures indicate, since inventory data are not collected from end-users of platinum, some of whom may hold sizable inventories (Ref. 2-4).

The U.S. National Defense Stockpile consists of 93 minerals, metals, and other materials stored at 114 locations in the United States. Total stocks of platinum in the stockpile amount to 453,000 troy ounces, which is equivalent to about a four-month platinum supply for all domestic industries. The purpose of the stockpile is to ensure that the United States will have available the necessary raw materials to support military and essential civilian requirements during periods of extended conflict or other disruption of foreign supplies. The stockpile goal is 1,314,000 troy ounces of platinum; enough to supply only these essential requirements for a three-year period. The current platinum stockpile amounts to only 34 percent of this goal, and platinum has not been added to the stockpile for a number of years. In fact, nearly the entire platinum inventory is more than 20 years old, and none of this inventory meets both the current chemical requirements for purity and physical requirements for form. Only 65 percent of the current inventory meets or exceeds the 99.95 percent purity specification. The entire inventory is in bar, plate, or sheet form in contrast to 1976 purchase specifications that changed the form to metallic sponge (Ref. 2-2).

The goals and policies of the National Defense Stockpile have varied frequently since its inception in 1939. The Strategic and Critical Materials Stockpiling Revision Act was enacted in 1979 to lay the groundwork for a uniform national policy regarding stockpiles. The Act directs the President to determine those materials necessary to sustain the military and essential civilian activities of the nation for three years. The Congress can authorize sales and purchases of stockpile materials and can appropriate money for buying the materials. It can make acquisitions and sales independent of economic or budgetary pressures. The Act also creates a Stockpile Transaction Fund so that money derived from stockpile sales can be accumulated for stockpile purchases (Ref. 2-8).

**ORIGINAL PAGE IS
OF POOR QUALITY**

The Government's immediate concern is the elimination of shortages of strategic materials listed as critical, particularly the platinum group metals, cobalt, chromium, manganese, and tantalum. As a result of changes in U.S. stockpile goals, there are plans to sell some of the surplus minerals and metals in the stockpile. The market value of the surplus materials, particularly the silver and tin, is larger than the cost of purchasing the deficient critical materials; however, Congress is reluctant to sell the silver surplus, and the world demand for tin is currently depressed (Ref. 2-8).

In short, private platinum inventories (502,185 troy ounces in 1980) and government platinum stockpiles (453,000 troy ounces) compose a valuable domestic reserve of the metal. However, in contrast to private inventories that are readily usable upon demand, government stockpiles are held off the market as a safeguard against supply emergencies. In addition, the majority of the platinum in the government stockpiles is not of the form and purity that lends itself to immediate use by industry.

2.2.8 Components of U.S. Platinum Supply

The U.S. supply of platinum is derived from three main sources: (1) imported platinum, (2) domestic industrial stocks of platinum, and (3) secondary refined (recycled) platinum. A very minor portion of supply is provided by domestic production of platinum. Table 2-5 lists and quantifies the components of U.S. platinum supply from 1969 through 1979. The levels of industrial stocks and exports fluctuated during these years while domestic demand expanded tremendously (from 517,000 troy ounces in 1969 to 1,409,000 troy ounces in 1979). The apparent surplus or deficit for each year is composed of unaccounted platinum distribution.

2.2.9 Platinum Supply Forecast

The world is projected to consume approximately 75 million troy ounces of primary platinum during 1978-2000, a third of which will be consumed by the United States (refer to Section 2.3.5). World reserves of platinum (estimated to be about 520 million troy ounces) are more than sufficient to meet this demand; however, world production of primary platinum will have to be expanded from the 1978 level of 2.7 million troy ounces per year to approximately 4.5 million troy ounces per year in 2000. This represents an average annual production growth rate of 2.4 percent over this period. Nearly two-thirds of the current world supply of platinum is provided by South Africa, and it is likely that the burden of supplying the bulk of expanded world production will fall to South African producers. Despite its huge platinum resources, the United States will probably supply only a small fraction of the world's platinum during the next two decades; and the platinum production of Canada and the Soviet Union is closely tied to the future demand for copper and nickel and thus is somewhat unreliable.

Explicit forecasts of world platinum production are not generally made because it is assumed that the platinum-producing countries will be capable

Table 2-5. Components of U.S. Platinum Supply, 1969-1979 (Ref. 2-1)
(thousand troy ounces)

	<u>1969</u>	<u>1970</u>	<u>1971</u>	<u>1972</u>	<u>1973</u>	<u>1974</u>	<u>1975</u>	<u>1976</u>	<u>1977</u>	<u>1978</u>	<u>1979</u>
Domestic production	177	191	167	58	38	20	20	1	1	1	2
Imports	379	540	492	673	886	1,363	980	1,138	931	1,258	1,482
Secondary Refined	127	118	103	76	95	96	104	65	51	76	75
Industry Stocks, Jan 1	<u>305</u>	<u>361</u>	<u>292</u>	<u>386</u>	<u>427</u>	<u>487</u>	<u>533</u>	<u>621</u>	<u>536</u>	<u>438</u>	<u>370</u>
Total U.S. Supply	988	1,210	1,056	1,193	1,406	1,926	1,637	1,635	1,519	1,773	1,929

ORIGINAL PAGE IS
OF POOR QUALITY

of expanding their production facilities to match any reasonable forecasts of world platinum consumption. South African producers closely monitor platinum usage trends, and recognize that platinum has the potential for a wide variety of new uses and will be required in ever greater quantities in the years ahead. Since the 1950s, a series of expansion programs have been implemented by South African producers to match the increase in world demand for platinum. In recent years, great attention has been given to mine productivity, involving new mining methods as well as mechanization of both underground and surface operations. These have resulted in higher worker outputs and a high degree of operation control. Expansion and investments of capital are based upon carefully researched estimates of future world requirements. Shifting economic cycles and the 18 to 24 months of lead time required to establish new capacity have made it difficult for South African producers to achieve a close balance between supply and demand. On several occasions, expansion programs have been postponed because of downward swings in the platinum demand cycle. For these reasons, South African producers generally take a long-term view of world platinum demand in order to justify the investment of expansion capital and the employment of thousands of additional workers that are needed to boost platinum output (Ref. 2-7).

Only a fraction of a percent of annual U.S. platinum demand through the year 2000 is forecast to be supplied by domestic mines. Domestic reserves are small, and although domestic resources are huge, only the Stillwater Complex and Duluth Gabbro have been sufficiently explored to indicate that mining for PGMs is a possibility. Other deposits are poorly explored, and there is no assurance that they could be developed successfully. Although production from Alaskan placers has recently resumed at Goodnews Bay, these deposits are small compared with U.S. requirements. By-product production, nearly all from copper mining, will be about 2,000 troy ounces in 1990 and reach 4,000 troy ounces in 2000 (Ref. 2-1).

In addition to the earlier known Goodnews Bay, Alaska, deposits, three other major potential PGM producing areas were identified in the United States in the mid-1960s and 1970s: the Stillwater (Montana), Duluth (Minnesota), and Crillion-La Perouse (Alaska) Complexes. Development interest is primarily centered on the Stillwater Complex which has several zones of varying PGM concentration. Stillwater PGM Resources, a joint venture of Manville Corporation and Chevron USA, Inc., has done extensive exploration and mapping within the Stillwater Complex to determine if commercial development is feasible. A final decision on whether to proceed with a development project is expected in 1983 (Ref. 2-4). Among the factors affecting this decision are marginal economic conditions and environmental constraints. Domestic platinum production will probably remain far short of satisfying domestic platinum demand unless the Stillwater deposit is developed. This deposit could supply about one-quarter of the U.S. requirement for platinum (Ref. 2-1). The Duluth Complex has not been studied as extensively as the Stillwater Complex and no development plans have been proposed. The Crillion-La Perouse Complex has only been partially explored and it, too, has not been the subject of serious development proposals. Development of

domestic platinum resources would decrease reliance on imports, but even if sizable mines are developed in Montana, Minnesota, or Alaska, it is probable that the United States would continue to import a significant portion of its supply of primary platinum (Ref. 2-1).

Approximately one-third of the current world production of platinum is a by-product of copper and nickel mining in Canada and the Soviet Union. The growth of platinum production from these sources will be a function of the growth of copper and nickel production in these two countries. The Bureau of Mines forecasts that, from 1978 to 2000, the world demand for copper will increase at an average annual rate of 3.6 percent. During this same time period, the world demand for nickel is forecast to grow at an average annual rate of 3.9 percent (Ref. 2-1). These forecasts indicate that the supply of platinum from these sources should continue to increase during the next two decades as long as each country maintains its share of the copper and nickel markets.

2.2.10 Substitutes for Platinum

Platinum is a relatively high priced metal and is therefore used only where well justified for technical and economic reasons. Substitution for platinum can include direct replacement of platinum components by other materials, replacement by other elements in compounds or alloys, or replacement of solid platinum components by a base metal support clad with platinum. In many platinum applications, however, substitutions are not feasible or are distinctly inferior.

In general, it is more expedient to substitute metals of the platinum group for one another, especially in alloys, rather than use alternative materials. For example, platinum and palladium are interchangeable to a limited extent in dental alloys, and the higher cost of platinum has led to the enhanced use of palladium-containing alloys (Ref. 2-1).

Several types of catalysts may replace platinum in chemical synthesis, but with penalties in efficiency and usually in capital and operating costs. Examples are catalysts containing the transition metals, such as rare-earth elements, nickel, molybdenum, tungsten, chromium, cobalt, vanadium, and silver, and their compounds. The recent widespread introduction of bimetallic catalysts in petroleum reforming is one instance where significant improvement in performance and durability resulted from substitution. These bimetallic catalysts replace about one-fifth of the platinum metal content in the catalyst with rhodium. The development of a non-PGM catalyst for automobile emission control would cause a substantial decrease in platinum use. Although such a catalytic breakthrough cannot be discounted, neither can it be predicted nor relied upon to occur at any particular point in the future (Ref. 2-2).

Alternatives to platinum use in electrical applications include tungsten, nickel, gold, and silicon carbide. In several of the platinum uses where corrosion resistance is crucial, other materials, such as stainless steel

and ceramics, can sometimes be used. These substitutes may have a shorter useful life, however, and some contamination of the product may result from their use. Platinum alloys are ideal jewelry materials and are projected to capture a growing share of the jewelry material market. Possible substitutes for this growth include other PGMs, particularly palladium, and, of course, the precious metals gold and silver.

The volume of platinum that will be displaced by other materials in the future is dependent on the price of platinum relative to other suitable materials and the development of new materials capable of meeting minimum standards. As the price of platinum rises relative to other materials, it may at some point become more economical to use less expensive substitutes even though reductions in performance or product quality may result. The high price of platinum also stimulates research activities that strive to develop cheaper, more abundant substitutes for its use. Development of alternative catalysts in several key applications could significantly reduce overall platinum usage.

2.3 PLATINUM DEMAND MARKET

2.3.1 U.S. and World Consumption

About two-thirds of the world's PGM production is consumed by the United States and Japan, with Western Europe and the Soviet Union dividing most of the remainder. The changing pattern of platinum consumption in the U.S. is indicated by Table 2-6 which lists the platinum sales to consuming industries for the years 1969 through 1980. The end-use pattern changed in 1974, the first year in which platinum-palladium catalysts were used extensively in automobile emission-control devices.

The statistical data given in Table 2-6 do not represent actual consumption figures, but rather are sales to major consuming industries. These data are obtained from reports submitted by refiners, dealers, and consumers. The Bureau of Mines estimates sales figures when reporting is incomplete. The totals shown include primary and nontoll-refined secondary metals, but do not include toll-refined metals. They are restricted to material processed no further than the initial stages of fabrication.

The United States and Japan are the only major countries for which data on consumption of PGMs are available. With the exception of Japan, the pattern of platinum consumption, excluding automobile catalysts usage, in all industrialized countries is believed to be similar to that of the United States. In Japan, about 70 percent of the platinum goes into jewelry, whereas in the United States and Western Europe only 5 to 15 percent is used in jewelry. In 1979, world sales of platinum were estimated to be about equally divided between jewelry, general industrial, and automotive industries (Ref. 2-1).

Table 2-6. U.S. Platinum Demand Pattern, 1969-1980 (Refs. 2-1, 2-4)
(thousand troy ounces)

	1969	1970	1971	1972	1973	1974	1975	1976	1977	1978	1979	1980
Automotive	--	--	--	--	--	350	273	481	354	598	803	517
Chemicals	175	148	135	226	239	216	149	84	84	150	99	118
Petroleum Refining	62	145	137	99	124	139	108	59	75	108	170	144
Glass	62	47	41	27	72	74	34	42	60	98	88	52
Electrical	112	103	52	92	117	99	74	89	90	106	116	150
Dental & Medical	22	18	23	30	28	26	17	27	27	44	27	25
Jewelry	36	29	19	21	22	23	23	23	35	26	28	50
Other	47	19	20	50	56	17	21	46	65	66	78	58
Total Demand	517	509	427	545	638	944	699	851	790	1,196	1,409	1,118

Table 2-7. Distribution of U.S. Platinum Supply (Ref. 2-1)
(thousand troy ounces)

	1969	1970	1971	1972	1973	1974	1975	1976	1977	1978	1979	1980
Industry Stocks, Dec 31	361	292	386	427	447	533	421	421	536	438	370	305
Govt. Acquisitions	--	--	3	--	--	--	--	--	--	--	--	--
Exports	224	226	241	346	381	401	328	225	214	248	248	195
Demand	517	509	427	545	658	944	699	851	790	1,196	1,409	1,409
Apparent Surplus (+), Deficit (-)	-114	+183	-3	-125	-40	+48	+189	+23	+77	-41	-80	-80
Total U.S. Supply	988	1,210	1,054	1,193	1,446	1,926	1,637	1,635	1,519	1,773	1,929	1,929

ORIGINAL PAGE IS
OF POOR QUALITY

2.3.2 Distribution of U.S. Platinum Supply

The U.S. platinum supply consists of domestically produced platinum, imported platinum, secondary refined (recycled) platinum, and domestic industrial stocks of platinum. This supply is distributed to meet the requirements of domestic industrial demand, domestic industrial stocks, and exports. A portion of the supply may also be acquired by the government for addition to the national stockpile. Table 2-7 quantifies the distribution of the total U.S. platinum supply in each year from 1969 through 1979. The level of industrial stocks and exports fluctuated during these years, while domestic demand expanded tremendously (from 517,000 troy ounces in 1969 to 1,409,000 troy ounces in 1979). The apparent surplus or deficit for each year is composed of unaccounted platinum distribution. The platinum distribution figures of Table 2-7 correspond to the platinum supply figures of Table 2-5 (page 2-21).

The platinum supply-demand relationship for the United States in 1978 is shown in Figure 2-5. As is typical, imported platinum provided the majority of U.S. platinum supply in 1978, and the overwhelming majority of these imports came directly or indirectly from the Republic of South Africa. Large quantities of platinum were both exported and retained in industrial stocks, and of the platinum actually used by U.S. industries, approximately half was consumed by the automotive industry for catalytic converters. Figure 2-4 does not count secondary toll-refined platinum as a supply source since it remains the property of the industrial user during reprocessing.

2.3.3 Specific Uses of Platinum

This section outlines typical uses of platinum in the major industrial categories of Table 2-6. The special properties of platinum and its alloys on which their industrial use depends include: extensive and sometimes unique catalytic activity; resistance to corrosion and oxidation, even at high temperatures; and high melting points and great strength. Substitutes for platinum are not often feasible and are usually distinctly inferior.

Figure 2-6 illustrates the uses of platinum in the United States in 1980. The overwhelming majority of all sales of platinum to the automotive, petroleum, and chemical industries are for catalytic uses (Ref. 2-2). Figure 2-7 divides 1980 U.S. demand into its industrial categories.

Automotive Industry - Platinum-palladium exhaust catalysts have been used to reduce the emission of carbon monoxide and hydrocarbons from light-duty vehicles since 1974. This is the largest single use of platinum in the United States, accounting for 57 percent of demand in 1979 and 46 percent of demand in 1980. A typical automobile exhaust catalyst contains about 0.05 troy ounce of platinum-palladium in a 70:30 ratio. Exhaust catalysts are poisoned by lead and so it was necessary to market lead-free gasoline in 1974. Catalysts are typically supported on ceramic monoliths or alumina pellets and the former are wash coated with an alumina layer prior to impregnation with the catalyst. The strong influence that domestic

ORIGINAL PAGE IS
OF POOR QUALITY

Figure 2-5. Platinum Supply-Demand Relationship for the U.S. in 1978 (Ref. 2-1)
(thousand troy ounces)

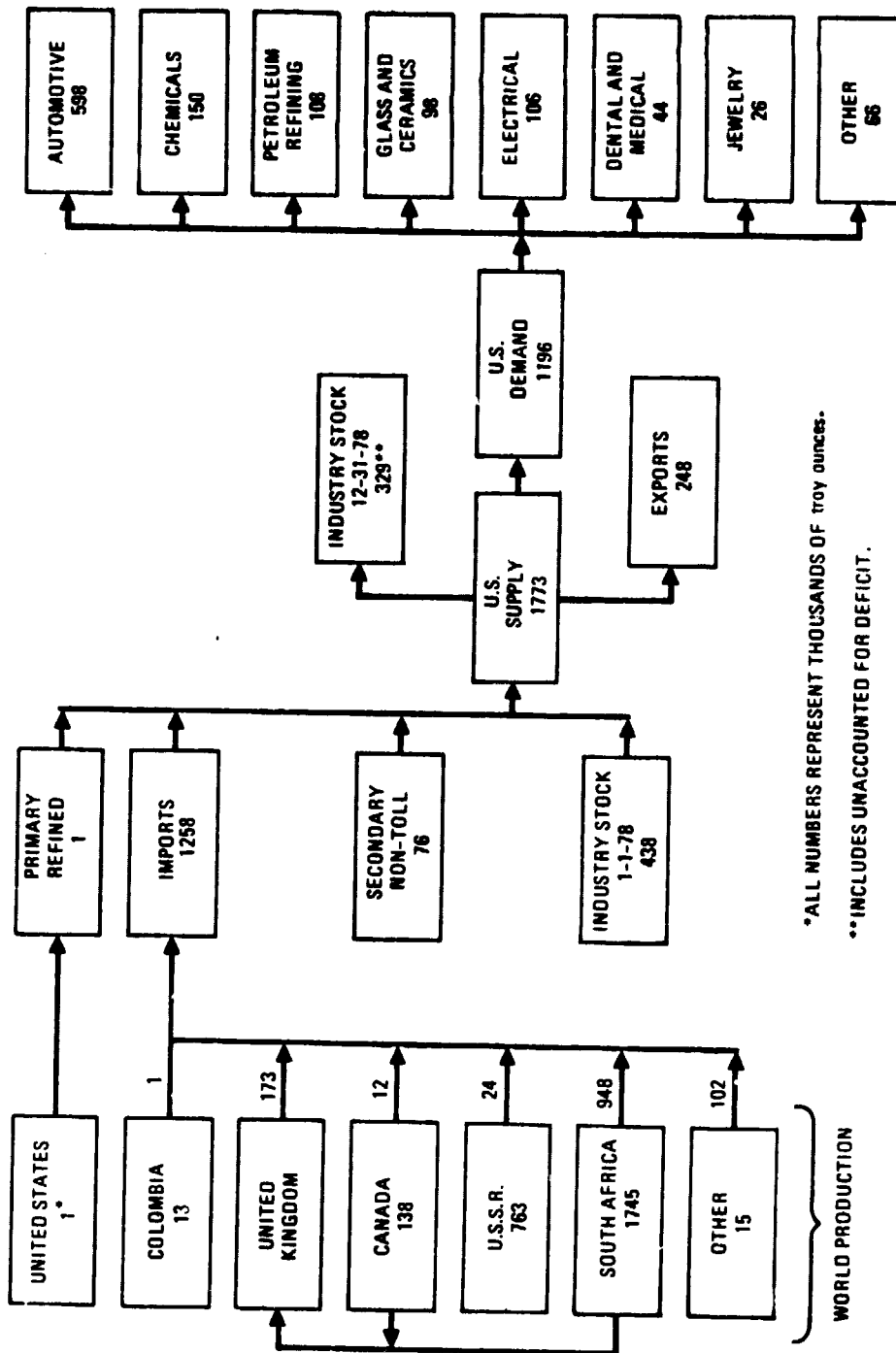

*ALL NUMBERS REPRESENT THOUSANDS OF TROY OUNCES.

**INCLUDES UNACCOUNTED FOR DEFICIT.

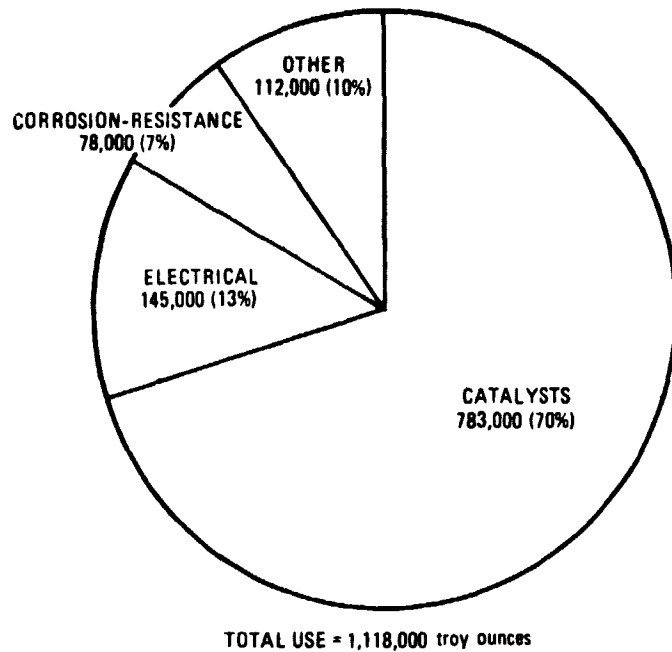

Figure 2-6. U.S. Uses of Platinum in 1980
(troy ounces) (Ref. 2-4)

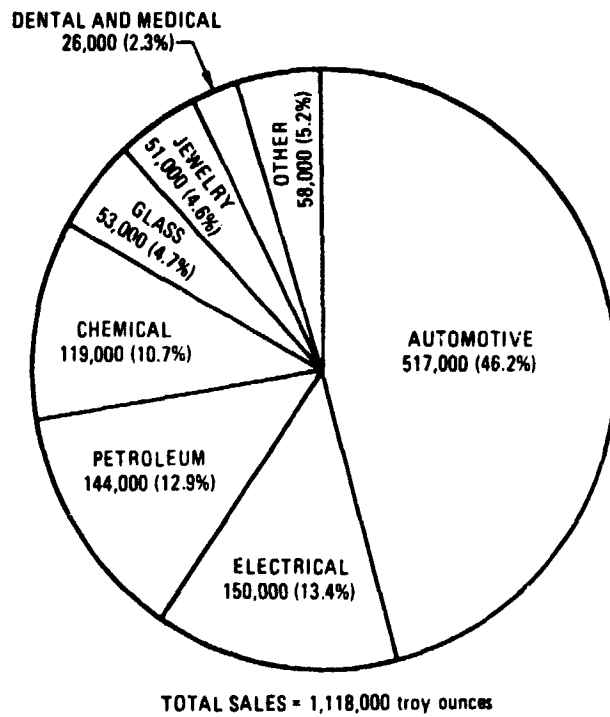

Figure 2-7. Platinum Sold to Consuming Industries
in the U.S. in 1980 (troy ounces) (Ref. 2-4)

automobile sales exert on total U.S. demand for platinum is evidenced by the demand figures for 1979 and 1980 shown in Table 2-6. The sharp drop in total U.S. demand for platinum in 1980 was caused almost entirely by lower automotive platinum demand that resulted from the slump in auto sales.

All methods aimed at reducing auto pollutant levels to meet emission standards are designed to give the best possible exhaust gas quality with the smallest possible reduction in vehicle performance. Prior to 1975, a combination of mechanical techniques, such as lean idle, spark retard, and exhaust gas recirculation, together with thermal reactors, was capable of meeting emission standards. Standards became more severe in 1975, and mechanical devices could no longer practically meet the requirements. Exhaust catalyst systems were introduced at this point and they not only enabled closer control of emissions, but also allowed engines to be retuned for greater fuel economy.

The progressive tightening of emission standards culminated in 1981 in the necessity to control nitrogen oxides by a method other than exhaust gas recirculation, since over application of this technique results in increased fuel consumption and poorer performance. Three-way exhaust catalysts were developed to meet this challenge. Three-way catalysts are so named because they simultaneously oxidize hydrocarbons, oxidize carbon monoxide, and reduce nitrogen oxides. Three-way catalysts are based on a platinum/rhodium system and their use caused rhodium consumption in the United States to rise sharply. In order for the three-way catalyst to operate properly, the stoichiometry of the gases entering it must be rigidly controlled. Such control is difficult under widely fluctuating auto operating conditions and, therefore, a different catalyst concept--known as the dual bed concept--was conceived for effective emission control. In the dual bed system, emissions are passed first through a three-way (platinum/rhodium) catalyst operating in the reducing mode and then through an oxidation catalyst (platinum/palladium). Air is injected into the exhaust system between the two catalysts. Much of the nitrogen oxides and some of the hydrocarbons and carbon monoxide are removed on the reducing catalyst and the remainder of the hydrocarbons and carbon monoxide is removed on the oxidation catalyst (Ref. 2-9).

Chemical Industry - The chemical industry uses platinum catalysts in the manufacture of a wide range of chemicals and pharmaceuticals. The chemical industry accounted for 7 percent of U.S. platinum demand in 1979 and 11 percent of U.S. platinum demand in 1980. In reporting platinum demand statistics, the Bureau of Mines assumes that all sales of platinum to the chemical industry are for catalytic uses. Only limited, and perhaps insignificant, noncatalytic uses of platinum have been identified in the chemical industry (Ref. 2-2).

The industrial use of platinum catalysts began with the first Ostwald process plants for oxidizing ammonia to nitric acid during World War I. This process utilizes stacked screens of platinum alloyed with rhodium or palladium. It is still the principal one used for nitric acid manufacture

ORIGINAL PAGE IS
OF POOR QUALITY

and is the single major chemical industry consumer of platinum. Nitric acid is used for the production of nitrogenous fertilizers (78 percent), explosives (12 percent), and miscellaneous applications (10 percent). The same catalyst is used in the Andrussov and Degussa processes for the manufacture of hydrogen cyanide from methane and ammonia. The hydrogen cyanide is used especially for the manufacture of methacrylate (Ref. 2-2).

PGM catalysts are broadly used elsewhere in the drug and chemical industry, but beyond ammonia oxidation, their use in large-scale processes has been relatively recent. For example, the hydrogenation of benzene to cyclohexane is done largely with homogeneous platinum, nickel, or cobalt catalysts, or platinum-nickel catalysts. Other catalytic uses of platinum in the drug and specialty chemical industry undoubtedly account for an important segment of the overall use, but they are so fragmented that a quantitative audit of their combined use does not seem possible (Ref. 2-2).

Platinum is widely used in chemical laboratories because of its resistance to chemical attack. Crucibles or combustion boats fabricated from rhodium-hardened platinum are used for high-temperature fusions and combustions. Platinum electrodes are used for electrodepositions and as low-corrosion anodes. The development of new manufacturing procedures has lessened the demand for these types of laboratory ware, however. No significant changes are foreseen in demand for other laboratory purposes (thermocouples, thermistors, electrodes, instrument components, etc.), but, in any event, the total consumption of platinum in such applications is relatively very small (Ref. 2-2).

The growth of single crystals of oxide compounds that melt at high temperatures requires the use of platinum and platinum alloys as crucible materials because platinum is suitable for use to 1500°C in oxidizing or reducing atmospheres. The most important single-crystal oxide compounds grown are: pure sapphire for semiconductor substrates, gadolinium gallium garnet for bubble memory devices, and neodymium-doped yttrium aluminum garnet and ruby for optically pumped lasers. Synthetic and imitation gemstones form a small but steady market, and minor amounts of lithium niobate and tantalate are grown as modulator and transducer materials (Ref. 2-2).

Petroleum Industry - Platinum and platinum-alloy catalysts are used in petroleum refining for hydrocarbon reforming, isomerization, and hydroprocessing. Platinum demand by the petroleum industry accounts for a significant share of total U.S. demand: 12 percent in 1979 and 13 percent in 1980. All petroleum industry platinum is used for catalytic purposes. The rather erratic purchase pattern for platinum by the petroleum industry, as revealed by Table 2-6, is apparently due to industry stockpiling of platinum in the early 1970s.

Hydrocarbon reforming is the major use of platinum by the petroleum industry. It is used mainly to upgrade the octane ratings of lighter fuel

ORIGINAL DOCUMENT
OF POOR QUALITY

components and isomerized butane for alkylation feed. The platinum contained in isomerization units was probably less than 100,000 troy ounces in 1978. Hydroprocessing is a rapidly growing refining process that can remove impurities, and therefore its use is limited to upgrading highly refined products, such as saturating the aromatic molecules of medicinal oils or hydrogenating diolefins out of gasoline produced by ethylene crackers (Ref. 2-2).

Glass Industry - Platinum and platinum alloys are used in glass melting furnaces and as liners in pots used to make optical glass because of their ability to withstand severe high-temperature corrosive conditions with little wear and without contaminating the glass. The glass industry accounted for 6 percent of total U.S. platinum demand in 1979 and 5 percent of total demand in 1980.

Pure platinum is used for glass melting tanks, stirrers, and crucibles for melting high-quality optical and special glasses. In glass fiber manufacture, platinum-rhodium bushings (perforated plates from which streams of molten glass emerge) are the major use of platinum in the glass industry. Similarly, platinum-rhodium alloys are used for crucible liners, structures for conveying molten glass, fiber-optics forming devices, laser-glass melters, and stirrers for glass homogenization (Ref. 2-2).

Electrical Industry - Platinum and platinum alloys are used in a wide variety of electrical and electronic devices, such as relays, voltage regulators, meters, thermostats, thermocouples, electric motor commutator rings, spark plugs, high-strength magnets, electron tubes, printed circuits, resistors, and various instruments. The applications for platinum in this industry are probably more numerous, involve more product forms, and utilize a wider range of platinum alloy compositions than in any other industry. Usually, it is platinum's chemical inertness and/or thermal stability that justifies its use in electrical devices. The electrical industry accounts for a significant share of the total U.S. platinum demand: 8 percent in 1978 and 13 percent in 1980.

PGMs are used in low-voltage, low-current relays, such as telephone exchange relays, which are required to work reliably for decades. The chemically inert PGMs (usually palladium, but sometimes platinum) remain free of surface compounds that degrade electrical conductivity and contribute to electrical noise. In higher voltage relays, the hardness and high melting points of platinum-iridium and platinum-ruthenium alloys minimize wear and arc transfer of metal between contacts (Ref. 2-1).

In thin-film circuits and some silicon integrated circuitry, thin layers of platinum are used to provide reliable conductor adhesion. In thick-film and hybrid integrated circuits, compositions of gold and platinum are used for conductors. Platinum versus platinum-rhodium thermocouples are used in many industries to accurately measure high temperatures. Ultrapure platinum is used as a resistance thermometer. Platinum is used for heater windings, and platinum-rhodium alloys are used for furnace windings. Materials for spark

ORIGINAL PAGE IS
OF POOR QUALITY

plug electrodes include platinum and platinum-rhodium alloys. Fine platinum-iridium wire is used as fuse wire for explosive detonators (Refs. 2-1, 2-2).

Dental and Medical Industries - Platinum and platinum alloys are widely used in dentistry and medicine. Platinum adds strength and improves the color of gold-based dental alloys. It is used in orthodontic and prosthodontic devices because of its corrosion resistance and high strength. It is used as a firing mount and reinforcement in dental porcelains because it does not discolor the porcelain during firing. In medicine, platinum is used in cauterizing points, hypodermic needles, and the cases of implanted cardiac pacemakers. The primary medical use of platinum in humans is in cancer chemotherapy. It is administered in the form of an inorganic coordination complex and appears to be effective in the treatment of several types of cancers (Refs. 2-1, 2-2).

The dental and medical uses of platinum account for a minor component of total U.S. platinum demand. This component was 2 percent of total demand in both 1979 and 1980.

Jewelry Industry - Platinum has long been used in articles of jewelry because of its scarcity, value, strength, and workability. Hardened with iridium or ruthenium, platinum makes a secure mount for jewels, and its color makes it particularly suitable as a diamond mount. Platinum is also used in inks and pastes for the decoration of china, glass, and ceramics. Jewelry demand for platinum remained fairly constant during the 1970s but increased substantially in 1980. The jewelry industry accounted for 2 percent of total U.S. platinum demand in 1979 and 4 percent of total demand in 1980.

Platinum jewelry was very popular in the United States during the 1920s, but during World War II the use of platinum for jewelry applications was banned. Annual domestic demand has remained less than 30,000 troy ounces since then. Platinum jewelry is very popular in Japan, however, and the Japanese have consumed as much as 1.0 million troy ounces of platinum for jewelry annually. They have almost single-handedly made jewelry the world's largest consumer of platinum (Ref. 2-2).

Other Industries - Platinum and platinum alloys play important roles in many other industries. These miscellaneous uses accounted for 6 percent of total U.S. platinum demand in 1979 and 5 percent of total demand in 1980. Among other uses, platinum and its alloys are used for: spinnerets in the production of synthetic fibers, brazing alloys for jet engines, rupture discs, portable chlorine generators, galvanic systems for protecting ships and pipelines against corrosion, and electrocatalysts in fuel cells (Ref. 2-1).

2.3.4 Possible New Uses for Platinum

The unique characteristics of platinum and platinum alloys encourage ongoing research into innovative and important future uses of the metal. Just as

ORIGINAL PAPER OF POOR QUALITY

many current uses of platinum were nonexistent 25 years ago, future uses of platinum may greatly outnumber current uses. These future uses will likely rely on platinum's catalytic, refractory, and inert characteristics, and may include revolutionary applications in such fields as metallurgy, electronics, medicine, energy production, transportation, and pollution control.

The development and successful production of dispersion strengthened platinum and a number of its alloys are a recent important achievement in the metallurgy of platinum metals. These materials contain a uniform distribution of extremely fine refractory precipitate dispersed throughout the mass, and the mechanically worked material develops a highly fibrous recrystallation structure on annealing that is unusually stable. In this condition it is extremely resistant to creep failure at elevated temperatures. When under stress at 1400°C, dispersion strengthened pure platinum can endure for at least twice as long as an alloy of platinum with 40 percent rhodium, which is generally accepted as the strongest commercially available high-temperature alloy. Such materials can have future advantages in the construction of equipment required to operate in air at very high temperatures (Ref. 2-10).

Another metallurgical advance offering new applications potential is the development of platinum-enriched superalloys. The strongest conventional superalloys have relatively poor corrosion resistance, particularly in sulphidising atmospheres. The addition of platinum metals can significantly improve the corrosion resistance of superalloys and thus expand their application (Ref. 2-10).

Development is continuing on a catalytic engine, an internal combustion engine where the heat release is brought about by a catalyst. The advantages of a catalytic combustion system incorporating PGM include the ability to burn fuel more cleanly and efficiently than conventional internal combustion engines. Other catalytic developments include commercialization of a catalytic converter to decompose ozone and a catalytic combustor to reduce the ignition point of wood-burning stoves (Ref. 2-4).

Programmable read-only memory fuses which utilize platinum silicide fuse links are reported to have significant advantages over the nickel-chrome fuses commonly used. The platinum silicide fuse, when blown, forms a gap up to 10 times longer than that formed by nickel-chrome materials, retarding regrowth of the fuse link (Ref. 2-6).

The electrochemical properties of platinum are finding growing applications in medical detection and stimulation devices. The development and testing of new platinum coordination complexes for use as cancer-inhibitory compounds are being actively pursued.

New platinum alloys with improved properties and casting characteristics have been developed to increase efficiency in investment casting of platinum jewelry.

2.3.5 Platinum Demand Forecast

The consumption of PGMs, though subject to changes caused by technical innovation, has shown a consistent and substantial growth throughout the past 25 years. In view of the essential role played by these metals in the industrial economy of the United States and other countries, especially in a number of applications concerned with fuel production, environmental protection, and provision of alternative energy supplies, this growth trend is expected to continue into the future. Several recent studies have forecast growth rates and demand levels for PGMs. Herein are summarized the results of three recent forecast studies: (1) The Global 2000 Report to the President (1980) (Ref. 2-11), (2) the 1980 Bureau of Mines PGM forecast (Ref. 2-1), and (3) the 1980 PGM forecast by the National Materials Advisory Board (Ref. 2-2). All three studies agree that domestic and world demand for platinum, and PGMs as a whole, will continue to climb for the remainder of the century; but the studies differ in their projected rates of growth.

The Global 2000 study forecasts future world and U.S. demand (consumption) for 18 nonfuel minerals, including PGMs as a composite. These forecasts are based on the forecasts of two previous studies: (1) the 1975 Bureau of Mines forecast (Ref. 2-12), and (2) a set of projections prepared by Wilfred Malenbaum, University of Pennsylvania, in 1977 (Ref. 2-13). The Global 2000 Report combined aspects of both previous studies in order to project 1985 and 2000 demand levels for the United States and nine other countries or global regions. These projections are given in Table 2-8, accompanied by the average demand figures for the years 1971-75 and average annual growth rates to the year 2000. U.S. demand for all metals of the platinum group is projected to grow at an average annual rate of 2.72 percent and reach 3,335,000 troy ounces by 2000. World PGM demand is projected to reach 14,030,000 troy ounces in 2000, with an average annual growth rate of 3.75 percent. As shown by Table 2-8, Japan is projected to be the leading PGM consumer in 2000, followed at a considerable distance by the United States, the U.S.S.R., and Western Europe. Third World countries are projected to still demand a minor share of world PGM supply by 2000.

The Bureau of Mines (BOM) is responsible for helping to ensure the continued strength of the domestic minerals and materials economy and the maintenance of an adequate minerals and materials base. In carrying out this responsibility, the Bureau develops forecasts of future trends in the supply and demand of minerals on a global basis for the purpose of identifying changes that might affect the national interest. Projections of future consumption are published by the Bureau every five years. The 1975 Bureau of Mines PGM forecast was used in the development of the Global 2000 study forecasts. The Bureau published an updated forecast in 1980 (Ref. 2-1). This forecast addressed each specific metal of the platinum group and projected U.S. and world consumption to 1990 and 2000. Table 2-9 summarizes the 1980 Bureau of Mines demand forecasts for all six PGMs taken as a group. A forecast range is provided for the year 2000. Domestic demand is forecast to grow at an average annual rate of 2.5 percent for the remaining years of this century, rising to 3.2 million troy ounces in 2000 (2.59

Table 2-8. The Global 2000 Study PGM Demand Projections
(thousand troy ounces) (Ref. 2-11)

	<u>Average 1971-75</u>	<u>1985</u>	<u>2000</u>	<u>Average Annual Growth (%)</u>
United States	1,660	2,442	3,335	2.72
Western Europe	653	948	1,391	2.95
Japan	1,765	3,146	5,765	4.66
Other Developed Western Countries	272	403	625	3.25
U.S.S.R. and Eastern Europe	702	1,218	1,806	3.70
Africa	38	65	129	4.81
Asia	141	242	418	4.27
Latin America	34	79	158	6.09
China	<u>123</u>	<u>210</u>	<u>343</u>	<u>4.02</u>
World Total	5,388	8,753	13,970	4.05

Table 2-9. Summary of Bureau of Mines PGM Demand Forecasts
(thousand troy ounces)

	<u>1978</u>	<u>1990</u>	<u>2000 Forecast Range</u>			Probable Average Annual Growth Rate <u>(%)</u>
			<u>Low</u>	<u>Probable</u>	<u>High</u>	
United States						
Annual ^a	2,260	2,700	1,790	3,240	5,110	2.5 ^c
Cumulative ^b	--	24,000	34,000	49,000	61,000	
Rest of World						
Annual	4,819	6,505	6,750	8,575	11,875	2.7
Cumulative	--	59,000	110,000	124,000	155,000	
World						
Annual	7,019	9,205	8,540	11,815	16,985	2.6 ^c
Cumulative	--	83,000	144,000	173,000	116,000	

^a Primary and secondary metal.

^b Primary metal only.

^c Calculated from the U.S. demand trend value of 1,868,000 troy ounces for 1978.

ORIGINAL PAGE IS
OF POOR QUALITY

ORIGINAL PAGE IS
OF POOR QUALITY

million troy ounces of primary metal and 0.65 million troy ounces of secondary metal). Demand in the rest of the world is forecast to grow slightly faster than the United States, reaching approximately 8.6 million ounces in 2000. At these growth rates, the United States will consume 49 million troy ounces of primary PGM in 1978-2000, and the rest of the world will consume 124 million troy ounces (Ref. 2-1).

A comparison of PGM demand forecasts made by the Global 2000 Report and the Bureau of Mines reveals that the Global 2000 Report projects a slightly higher demand growth rate for the United States (2.7 percent versus 2.5 percent) and a substantially higher demand growth rate for the world (3.75 percent versus 2.6 percent). Thus, while the two forecasts project a U.S. PGM demand in the 3.2 to 3.3 million troy ounces range by 2000, the Global 2000 Report forecasts a world PGM demand in 2000 that is approximately 2.2 million troy ounces greater than the Bureau of Mines forecast.

The 1980 mineral forecasts by the Bureau of Mines included a distinct set of demand forecasts for platinum. This set of forecasts is more relevant to the evaluation of the future platinum market since it considers platinum separate from the other PGMs. The platinum forecasts are shown in Table 2-10 and have the same format as the PGM forecast with the exception that the platinum demand is split into components for primary and secondary metal.

U.S. platinum demand is projected to grow at an average annual rate of 2.3 percent (from 1978 to 2000) and reach 1,495,000 troy ounces per year in 2000. This composite growth rate can be split into components for 1978-1990 (4.0 percent) and 1991-2000 (1.0 percent). U.S. demand for primary platinum metal is projected to grow at only a 1.6 percent average annual growth rate over this period and reach 1,195,000 troy ounces per year in 2000. These growth rates are calculated from the Bureau's 20-year U.S. primary platinum demand trend value of 840,000 troy ounces for 1978. Table 2-10 lists the actual 1978 U.S. primary platinum demand value of 1,120,000 troy ounces, which is considerably higher than the 20-year trend value. Growth rates based on this actual primary demand value (0.3 percent for primary platinum demand and 1.0 percent for total platinum demand) are much lower than the growth figures of Table 2-10. In fact, these figures actually show a small decline in U.S. demand for primary platinum during the 1980s. Although the forecasts range from 14 to 30 million troy ounces, the cumulative U.S. demand for primary platinum for 1978-2000 is expected to be 24.3 million troy ounces.

The world platinum demand is projected to grow at a 3.2 percent average annual rate and reach an annual demand level of 5,495,000 troy ounces by 2000. The primary metal component of this demand is projected to have a 2.9 percent average annual growth rate and rise to 4,470,000 troy ounces per year by 2000. This growth rate is also based on the 1978 demand trend value and is lower (2.4 percent) if the actual 1978 demand figure is used.

Table 2-10. Summary of Bureau of Mines Platinum Demand Forecast
(thousand troy ounces) (Ref. 2-1)

	1978	1990	2000 Forecast Range			Probable Average Annual Growth Rate (percent)
			Low	Probable	High	
United States						
Primary metal	1,120	1,100	605	1,195	2,020	1.6 ^a
Secondary metal	76	250	135	300	400	6.4
Total	1,196	1,350	740	1,495	2,420	2.3 ^a
Cumulative (primary) --		11,700	14,000	24,300	30,000	
Rest of World						
Primary metal	1,555	2,350	2,635	3,275	4,695	3.4
Secondary metal	300	500	590	725	770	4.1
Total	1,855	2,850	3,225	4,000	5,465	3.6
Cumulative (primary) --		23,300	46,000	51,400	65,000	
World Total						
Primary metal	2,675	3,450	3,240	4,470	6,715	2.9 ^a
Secondary metal	376	750	725	1,025	1,170	4.7
Total	3,051	4,200	3,965	5,495	7,886	3.2 ^a
Cumulative (primary) --		35,000	60,000	75,700	95,000	

^a Calculated from the 20-year Bureau of Mines U.S. demand trend value of 916,000 troy ounces of primary platinum for 1978.

The Bureau of Mines subdivided its 1980 platinum demand forecasts for the year 2000 into forecasts for major classes of consumers. These forecasts for the eight major classes of consumers are given in Table 2-11. In preparing its forecasts, the Bureau attempts to establish relationships between past consumption and economic indicators, such as gross national product, Federal Reserve Board indexes of industrial production, and population; however, correlations were poor for most of the statistical projections. The range of demand in each industry and the probable demand within that range were determined after analyzing economic, technological, and social trends pertinent to that industry (Ref. 2-1).

According to Bureau forecasts, the chemical industry will be the leading consumer of platinum in the United States in 2000 and will account for nearly half of the probable 2000 domestic consumption. The high platinum forecast for the chemical industry reflects the growth rate of gross private domestic investment in the chemical industry, while the low forecast reflects the high cost of energy and chemical feedstocks and the influence of a maturing economy. The probable forecast takes into account estimated demand for basic organic and inorganic chemicals (Ref. 2-1).

**ORIGINAL PAGE IS
OF POOR QUALITY**

Table 2-11. Bureau of Mines Forecasts for U.S. Platinum Demand by End Use
(thousand troy ounces) (Ref. 2-1)

	<u>2000 Forecast Range</u>			
	<u>1978</u>	<u>Low</u>	<u>Probable</u>	<u>High</u>
Automotive	598	60	150	500
Chemicals	150	300	700	900
Petroleum	108	50	60	250
Glass	98	80	120	150
Electrical	106	100	200	250
Dental and Medical	44	30	60	70
Jewelry	26	30	75	125
Other	<u>66</u>	<u>100</u>	<u>130</u>	<u>175</u>
Total	1,196	750	1,495	2,420

The Bureau forecasts that the use of platinum as an automotive-emission-control catalyst may well have been phased out by 2000 because of alternatives such as stratified-charge, diesel, and lean-burn engines; precise control of ignition and carburetion by electronic devices; improved fuels; and electric cars. The high automotive forecast, however, accounts only for the continued downsizing of vehicles, improvements in fuel mileage, and increasing numbers of nonconventionally powered vehicles. The low 2000 forecast assumes almost total platinum catalyst phaseout, with limited replacement of spent catalysts in older automobiles and retention of the catalytic converter on special vehicles.

The Bureau forecasts low platinum demand in petroleum refining if (1) lead compounds are retained in some gasolines, (2) engines capable of using low-octane gasolines are developed, (3) diesel engines capture a larger share of the engine market, or (4) nonplatinum petroleum-reforming catalysts are developed. The use of gasoline additives, such as alcohol, could also reduce demand. The probable forecast assumes that platinum will continue to be used in petroleum reforming, but in somewhat lighter loadings in multimetallic catalysts having a longer service life than present catalysts. Large use of platinum in oil shale or coal processing is not expected (Ref. 2-1).

According to the Bureau forecast, platinum demand in the glass industry will be high if (1) glass fiber continues to displace other textile fibers, (2) glass-reinforced plastics displace structural metals, and (3) high energy costs lead to greater use of glass fiber building insulation. Demand could be low, however, if housing construction rates decline. Use of platinum in electrical and electronic devices will be high if the economy expands and the use of computer and high-technology products increases as in the past. But demand will be low if substitute metals, miniaturization, and solid-state devices reduce platinum requirements. Demand for platinum in jewelry manufacture could increase greatly if the promotional campaigns of

ORIGINAL PAGE IS
OF POOR QUALITY

major producers are successful. The probable forecast reflects the Bureau's belief that there is ample room for growth in this market, as exemplified by the large Japanese demand for platinum jewelry. Interest in the buying and hoarding of platinum metal increased in 1979. Growth in this area could be substantial, depending on monetary uncertainties and world crises. Platinum usage for other purposes, such as in fuel cells, could offset declining use in some applications after 1990 (Ref. 2-1).

The National Materials Advisory Board (NMAB) of the National Research Council published a study in 1980 of PGM supply and use patterns. The study was based on 1977 PGM data and contained platinum consumption forecasts for the United States up through 1991. The Board analyzed past and present platinum usage trends, together with information available about proposed new uses, to develop their platinum consumption projections. Forecasts were made for each major class of domestic end user. As displayed in Table 2-12, separate forecasts were made for the 1979-1983, 1984-1988, and 1989-1991 time periods. The numbers in Table 2-12 are the average annual consumption figures for the respective time periods and represent total platinum demand (primary and secondary metal). Minor classes of end use were either grouped with the major classes or were not counted.

Table 2-12. U.S. Platinum Consumption Forecasts
of the National Materials Advisory Board
(thousand troy ounces per year) (Ref. 2-2)

Application	1977	Yearly Average		
		1979-1983	1984-1988	1988-1991
Automotive	357	761	615	505
Chemicals	84	186	229	252
Petroleum Refining	75	25	25	25
Glass	60	70	85	85
Electrical	90	127	155	238
Dental/Medical	27	34	39	45
Jewelry	35	100	150	225
Fuel Cells	1	16	168	340
Total	729	1,319	1,466	1,715

A comparison of Tables 2-10 and 2-12 reveals that NMAB forecasts a substantially higher 1990 domestic consumption of platinum (1,715,000 troy ounces) than does BOM (1,350,000 troy ounces). The NMAB and BOM platinum demand forecasts are also compared in Figure 2-8. Based on the actual U.S. total platinum demand of 1,118,000 troy ounces in 1980, the NMAB forecast represents a 4.4 percent average annual increase in demand during the 1980s, while the BOM forecast represents a 2.0 percent average annual increase. This discrepancy is probably attributable to three factors: (1) differences in consumption projections for the major end-user classes, (2) a large

ORIGINAL PAGE IS
OF POOR QUALITY

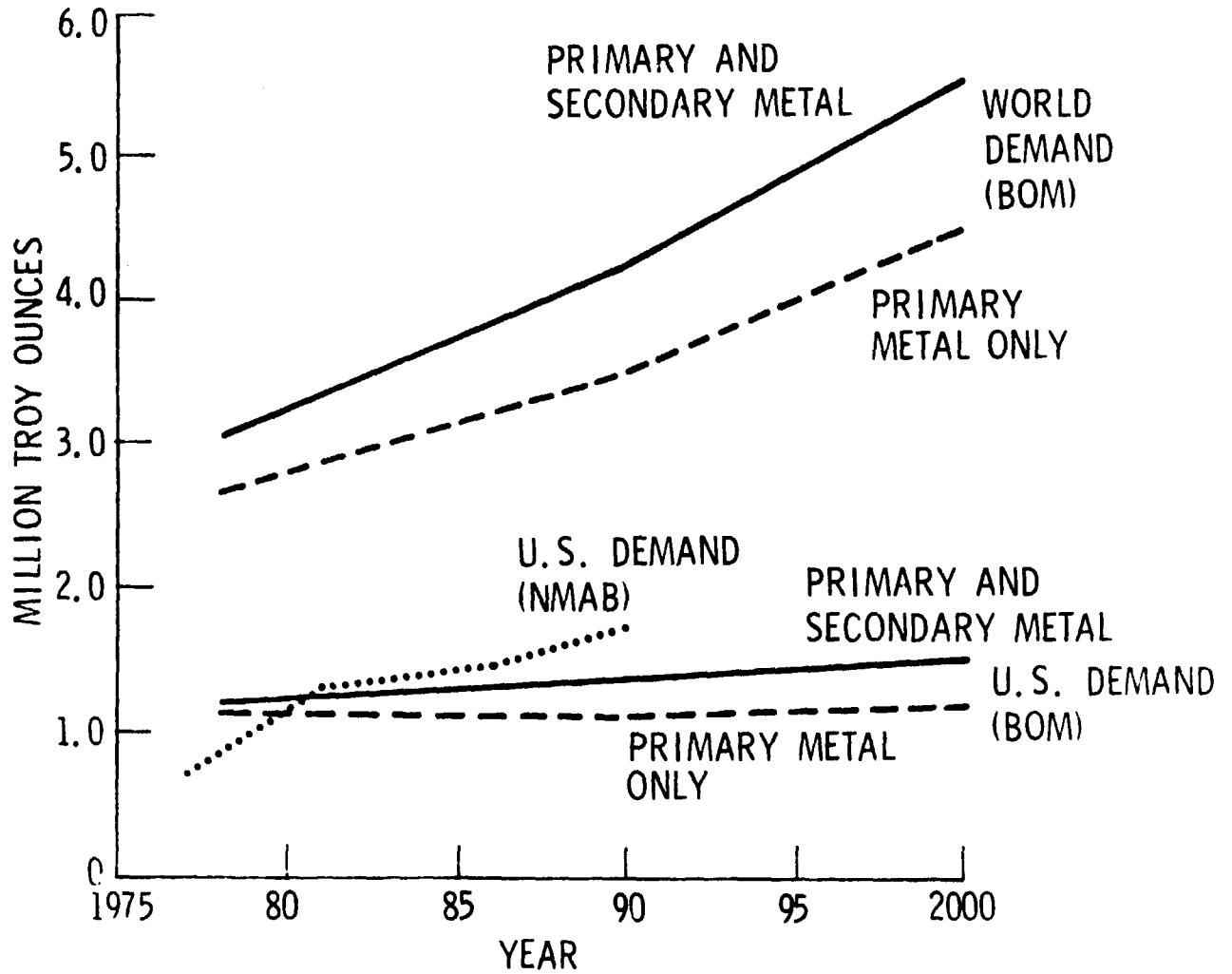

Figure 2-8. World and U.S. Platinum Demand Forecasts

platinum consumption by fuel cells projected by NMAB, and (3) a nonaccounting of minor classes of platinum consumers by NMAE. These factors are illuminated by Tables 2-11 and 2-12. Although the NMAB platinum end-use forecasts are for 1990 and the BOM end-use forecasts are for 2000, both reflect the same prevailing trends for the majority of end-use classes. For example, both forecasts project large consumption decreases by the automotive industry and large increases by the chemical industry. Both forecasts indicate decreases of comparable scale for the petroleum industry and increases of comparable scale for the glass, electrical, and dental-medical industries. A source of major disagreement between the two forecasts, however, is the projection of platinum consumption by the jewelry industry. Both forecasts anticipate a growing popularity of platinum jewelry in the United States due to promotional campaigns by suppliers and the example set by Japanese consumers, but while the NMAB projects an explosive growth in platinum consumption for jewelry (15 percent average annual growth rate, 1977-90), the BOM projects a significantly more modest growth (5 percent average annual growth rate, 1978-2000). The resulting difference in projected platinum consumption for jewelry is substantial.

The NMAB forecast projects a high level of platinum use in fuel cells by 1990. In fact, this average annual consumption rate of 340,000 troy ounces elevates fuel cells to the second leading consumer of platinum, behind only the automotive industry. The BOM forecast does not specifically address platinum consumption by fuel cells, but rather groups it under projected consumption by "other" industries. Table 2-11 clearly shows that BOM anticipates much lower platinum demand growth rate by fuel cells than does the forecast by NMAB. The total annual consumption in 2000 by all "other" industries as forecast by BOM is only 130,000 troy ounces of platinum and ranks fourth among classes of end-users.

The fact that the NMAB forecast does not account for platinum consumption other than by the major consuming industries is another distinction between the two forecasts. In 1978, for example, BOM estimated platinum consumption by these other industries to be 66,000 troy ounces. The consideration of this miscellaneous class of end-users by the NMAB would have likely raised their forecast totals by a significant amount.

In summary, the following important points can be highlighted from this brief review of the three platinum demand forecast studies:

- Domestic demand for platinum will experience a moderate average annual growth rate during the 1980s (BOM - 2.0 percent; NMAB - 4.4 percent), but the average annual growth rate will be substantially less during the 1990s (BOM - 1.0 percent).
- The United States will consume a cumulative total of 11.7 million troy ounces of primary platinum during 1978-1990 and 24.3 million troy ounces of primary platinum during 1978-2000.

ORIGINAL PAGE IS
OF POOR QUALITY

- World demand for platinum will grow at an average annual rate of 2.8 percent during 1978-1990 and 2.5 percent during 1991-2000. Beginning in 1978, the world will consume 35.0 million troy ounces of primary platinum by 1990 and 75.7 million troy ounces by 2000 (BOM).
- Domestic platinum consumption by most industries will rise during 1978-2000. The chemical industry will have a very high consumption growth rate, and the jewelry industry has the potential for a very high growth rate. Consumption by the automotive and petroleum industries is expected to decrease substantially. Platinum demand by fuel cells could be very high and might offset demand decreases in other industries.
- The uncertainty inherent in platinum demand forecasts is reflected by the wide forecast range of BOM projections. For example, the BOM platinum demand forecast for the United States in 2000 has a range from a low of 740,000 troy ounces to a high of 2,420,000 troy ounces.
- World demand for platinum is forecast by BOM to grow at a faster rate than the demand for PGM as a whole (3.2 percent vs. 2.5 percent average annual growth rate, 1978-2000). In fact, world platinum demand is forecast to grow faster than the demand for any of the other PGMs except rhodium. The projected average annual growth rate of rhodium of 4.0 percent (1978-2000) will likely stimulate platinum production, while the lower growth rates of the other PGMs may impede platinum production.

2.4 PLATINUM PRICES

There are basically three prices for platinum: the producer price, the dealer price, and the futures price. The producer price is set by Rustenburg Platinum Mines Ltd. and Impala Platinum Ltd., South Africa's two largest platinum producers. The dealer price is determined by several large bullion dealers in the United States and overseas. The futures price for various contract months is set on the New York Mercantile Exchange. Short-term price trends are generally set by the dealers and futures market and followed by the producers. The South African producers effectively control long-term price trends, however. On occasion, they have influenced the world platinum market prices by lowering their production and purchasing excess platinum in the marketplace (Ref. 2-1).

In general, the producer price applies to industrial accounts and to long-term purchases while the dealer price pertains to spot purchases. The futures price applies to hedging and speculative accounts. Most South African platinum is committed to major consumers and only a relatively small quantity is marketed through the dealers. Some automobile manufacturers have special contracts with South African producers that allow purchase of

platinum at less than the quoted producer price. The dealer market is largely fed by suppliers from Europe, including platinum from the Soviet Union (Ref. 2-1).

The price of platinum in dollars per troy ounce (\$/tr. oz.) was around \$80 in 1928 but fell to \$21 in 1933. In 1941-42, the price was at \$35 and started to move up in 1946 as more platinum was demanded by the petroleum industry for reforming catalysts. There was a price drop around 1954, but the general price upswing soon resumed. The gradual price climb continued until the mid-1960s when increased demand for platinum jewelry by the Japanese caused a steeper price climb. During 1973-74, the price surged as platinum began being used in catalytic converters. Although slowed by recession during the mid-1970s, the price of platinum shot up dramatically in 1978-79 as more platinum was demanded for use in catalytic converters and for investment purposes. Figure 2-9 charts the growth during 1945-1981 of both the world production of platinum and the producer price of platinum.

The correlation of producer and dealer prices for platinum is illustrated by Figure 2-10 for the period 1972-1981. The dealer price corresponds closely to market demand and is more dynamic than the producer price. Figure 2-10 highlights the point that the setting of the producer price is based on the price trends established by the dealer price.

The price of platinum is determined by a variety of technical, economic, and political factors. A brief recounting of the pricing history of platinum from 1974 through 1982 follows in order to elucidate the reasons for the radical price changes that occurred during this period. Some of this material is provided verbatim from the referenced source.

- 1974 - Reacting to speculative pressure, the price of platinum on the New York Mercantile Exchange hit a record high of \$315/tr. oz. in March. The price declined until June, however, as platinum followed the downward trend of the other precious metals, most notably gold. As the recession deepened later in the year and it became apparent the auto sales would not improve, both speculators and industrial users began to liquidate inventories. As a result, platinum prices fell and were in the \$150/tr. oz. range by mid-January of 1975. Platinum sales to most U.S. industries declined in 1974, but the drop was made up by the start of manufacture of catalytic converters. Platinum consumption by Japan declined drastically in the second half of 1974 as the Japanese jewelry industry was particularly hard hit by the recession (Ref. 2-14).
- 1975 - Platinum prices were on the defensive for the first half of 1975 as industrial demand declined from the previous year. The producer price began the year at \$190/tr. oz., some \$30 above dealer market prices, and was quickly cut to \$170 following extensive discounting by the producers. South African producers announced plans to trim output by 25 percent; but when this announcement failed to rally dealer prices, the producers were

ORIGINAL PAGE IS
OF POOR QUALITY

ORIGINAL PAGE IS
OF POOR QUALITY

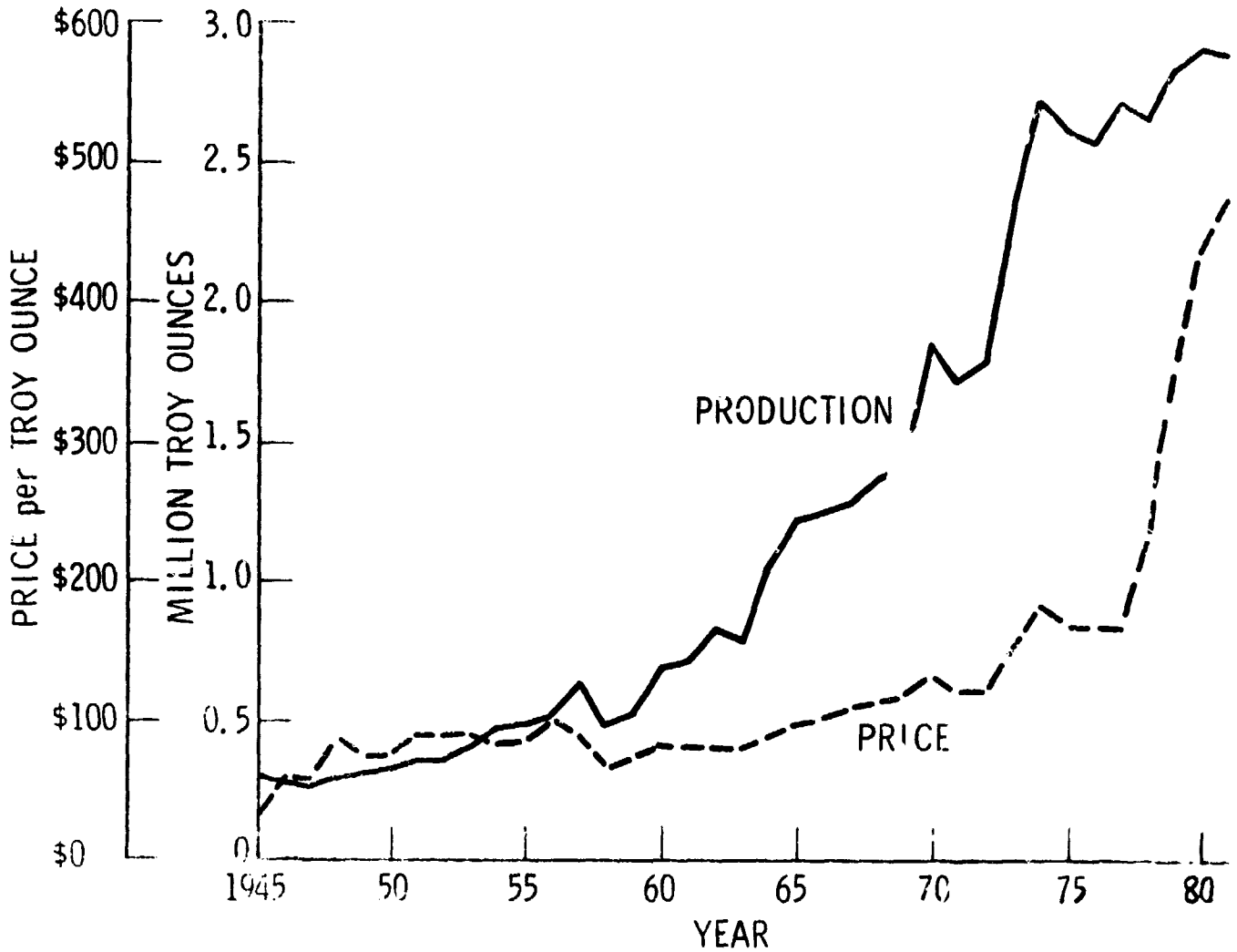

Figure 2-4. World Platinum Production Versus
Producer Price of Platinum, 1945-81
(Refs. 2-1, 2-5, 2-15)

ORIGINAL PAGE IS
OF POOR QUALITY

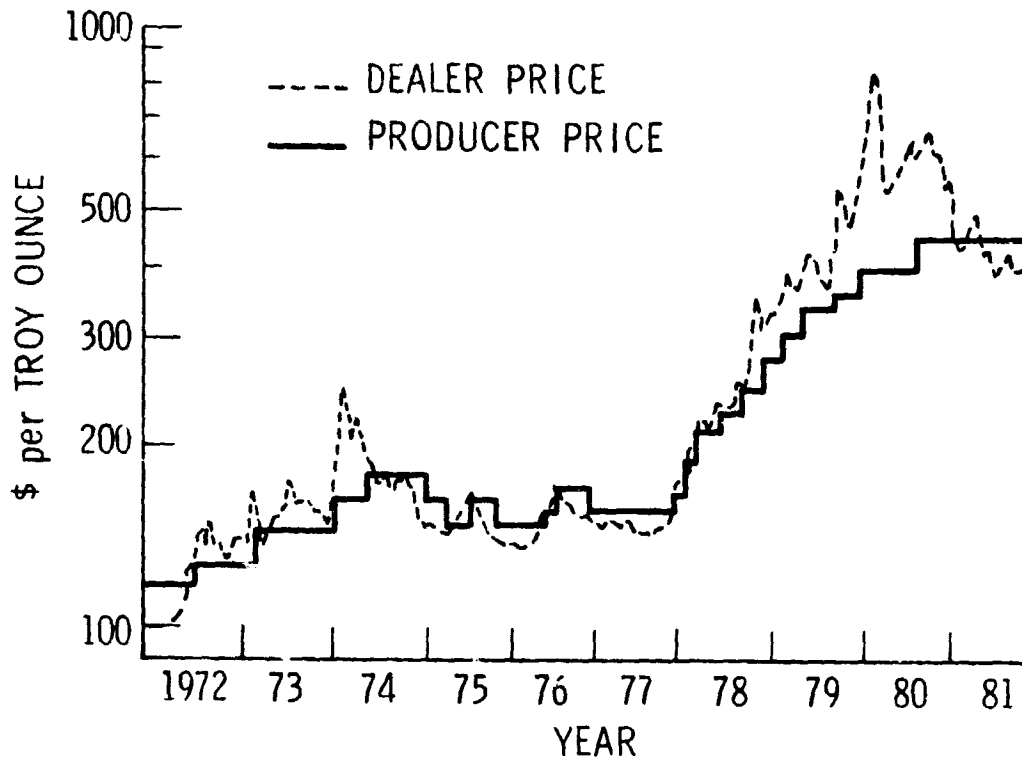

Figure 2-10. Dealer and Producer Prices of Platinum, 1972-1981
(Ref. 2-16)

forced to reduce their price in April to \$155. In June, heavy buying by Japanese and Swiss concerns caused the quantity of platinum stocks on the New York Mercantile Exchange to decline dramatically. Platinum prices were also strengthened by rising investments in precious metals because of inflation fears. The producers responded to higher dealer prices by quickly raising their price back up to \$170. However, without underlying support from U.S. consumers, the dealer market rally proved premature, forcing producers to again cut their price back to \$155 in October (Ref. 2-17).

- 1976 - World platinum production in 1976 matched production in 1975, but the price of the metal weakened because of declining consumption. The world's slow recovery from the recession coupled with a bad year for the Japanese jewelry industry was apparently responsible for the sagging prices. The price was strengthened somewhat by news that allayed fears that the use of catalytic converters might be terminated because of adverse effects from sulfuric acid emissions. The basic reason for platinum's price weakness was a continued slight surplus of platinum on the market which stood at about 175,000 troy ounces. At the end of 1976, the producer price was in the \$162-\$170/tr. oz. range and the dealer price ranged from \$150 to \$161 (Ref. 2-18).
- 1977 - Platinum prices were weak for most of 1977, but they forged ahead at the end of the year because of a pronounced change in supply. Platinum's dealer price jumped from a \$143/tr. oz. low in August to finish the year at \$186. Like other precious metals, platinum was spurred on by rising hedge demand generated by dollar weakness and other economic uncertainties. More importantly, however, the Soviet Union curtailed its platinum sales and shipments and South Africa, squeezed between rising costs and low prices, announced plans to reduce output. Soon afterwards, the dealer price climbed above the producer price of \$162. In November, Rustenburg raised its price to \$170 and in December Impala raised its price to \$180. The Impala increase was immediately matched by Rustenburg (Ref. 2-19).
- 1978 - During 1978, the dealer price of platinum rose to \$351/tr. oz. from \$190, an increase of 85 percent. The producer price rose 67 percent to \$300 from \$180. Both prices rose steadily during the year with the dealer price peaking at \$375 and then falling in November to \$315 following the announcement by President Carter of several measures aimed at supporting the dollar. Platinum prices during the year were subject to wide price fluctuations because of sharply increased speculative activity stemming from reaction to news of international economic and political significance. The weakening of the dollar led many domestic and foreign investors to alter their investment

ORIGINAL PAGE IS
OF POOR QUALITY

strategy and increase their holdings of precious metals, including platinum. Increased industrial demand from the United States and strong demand from Japan for platinum jewelry, coupled with decreasing supplies from the Soviet Union, were also bullish factors in the market. In general, the market was characterized by tight supply and sharply rising prices (Ref. 2-20).

- 1979 - During 1979, the dealer price of platinum rose to \$638/tr. oz. from \$339 at the beginning of the year, an increase of 88.2 percent. The producer price rose to \$420 at the end of 1979, an increase of 40 percent from the \$300 price at the start of the year. Both prices rose steadily throughout most of the year; however, fueled by speculators and the fact that the Soviet Union stopped delivering platinum to the United States because of the Afghanistan situation, the dealer price shot up in the latter part of 1979 and was not followed by the producers. The producers decided to wait until dealer prices stabilized before setting a new price. Generally, as in 1978, the market was characterized by tight supply and strong industrial demand (Ref. 2-21).
- 1980 - The dealer price for platinum rose as high as \$1,055/ tr. oz. in March of 1980 before declining to a \$600-\$700 range in April. The producer price deviated only slightly, rising from \$420 at the beginning of the year to \$475 by year's end.
- 1981 - The dealer price for platinum declined sharply in 1981. It was at its highest in January (\$565/tr. oz.) and declined steadily throughout the year. By October, the dealer price had slid below the producer price and it finished the year in the \$400 neighborhood. The producer price remained at \$475 throughout the year. U.S. imports of platinum declined approximately 14 percent in 1981 (Ref. 2-5).
- 1982 - The dealer price of platinum continued to decline in the first half of 1982. By March, it had fallen to about \$320/tr. oz. and in June it hit a low of \$250. The price moved back up to \$300 in July. The producer price remained fixed at \$475 throughout the first half of 1982. The recession and high interest rates are blamed for reducing industrial demand for platinum and moving investments out of precious metals and into high-interest accounts (Ref. 2-22).

A large part of platinum's tremendous price increases during the late 1970s was actually due to the influence of inflation. Figure 2-11 charts two platinum prices from 1970-1981: the actual producer price and the producer price in terms of constant 1970 dollars that removes the influence of inflation. While the actual price rose from \$125/tr. oz. to \$475/tr. oz. during this period, the constant dollar price rose only to approximately \$200/tr. oz. The constant dollar price was in fact lower in 1977 than in

ORIGINAL PAGE IS
OF POOR QUALITY

1970. From 1977 through 1981, the constant dollar price approximately doubled (\$100 to \$200/tr. oz.) while the actual price nearly tripled (\$162 to \$475/tr. oz.).

The price index trends for two important world commodities, oil and gold, are shown in Figure 2-12 for the period 1970-80. The steep rise in these two price indices is indicative of both a high inflation rate and increased speculative buying of precious metals due to a variety of political and economic events. The price of platinum was strongly influenced by both of these factors during this period.

PGM production employs relatively few persons in the United States and probably less than 500 persons are involved domestically through the semifabrication stage. In South Africa, however, where PGM production is a major industry and the mining is labor intensive, total employment has been estimated at about 85,000 persons. Productivity is approximately 35 to 40 ounces of PGM per worker-year. In 1975, capital and operating costs for a medium-sized PGM refinery in South Africa were estimated at about \$31 and \$7, respectively, per ounce produced. The high costs were mainly attributed to high labor and capital costs and to the expensive equipment involved (Ref. 2-1).

The United States imported 1,437,574 troy ounces of platinum in 1980 valued at \$697.9 million. This was substantially larger than U.S. platinum exports in 1980 of 462,507 troy ounces (valued at \$241.7 million) and yielded a platinum trading deficit for the United States of \$456.2 million. Table 2-13 lists the quantities and values of U.S. platinum imports and exports for 1970 through 1980. The large growth in the deficit resulting from the platinum trade is due to both the growth in import quantities and the tremendous growth in platinum price. The platinum trade deficit represented 1.7 percent of the total 1979 U.S. trade deficit of \$27.6 billion and 1.9 percent of the total 1980 U.S. trade deficit of \$24.2 billion (Ref. 2-22).

Table 2-13. Value of U.S. Platinum Imports and Exports (Ref. 2-22)

Year	Imports		Exports		Pt Trade Deficit (\$M)
	Troy Oz.	Value (\$M)	Troy Oz.	Value (\$M)	
1970	439,331	50.0	270,584	33.0	17.0
1971	439,956	47.5	320,842	29.4	18.1
1972	483,637	57.5	417,037	44.3	13.2
1973	674,132	85.7	439,452	61.4	24.3
1974	1,103,631	269.7	474,494	78.1	191.6
1975	683,349	272.8	376,450	56.4	216.4
1976	1,000,000	291.5	325,805	52.7	238.8
1977	778,475	129.2	289,307	46.5	82.7
1978	1,121,582	292.7	345,557	81.9	210.8
1979	1,360,286	605.3	397,050	139.7	465.6
1980	1,437,574	697.9	462,507	241.7	456.2

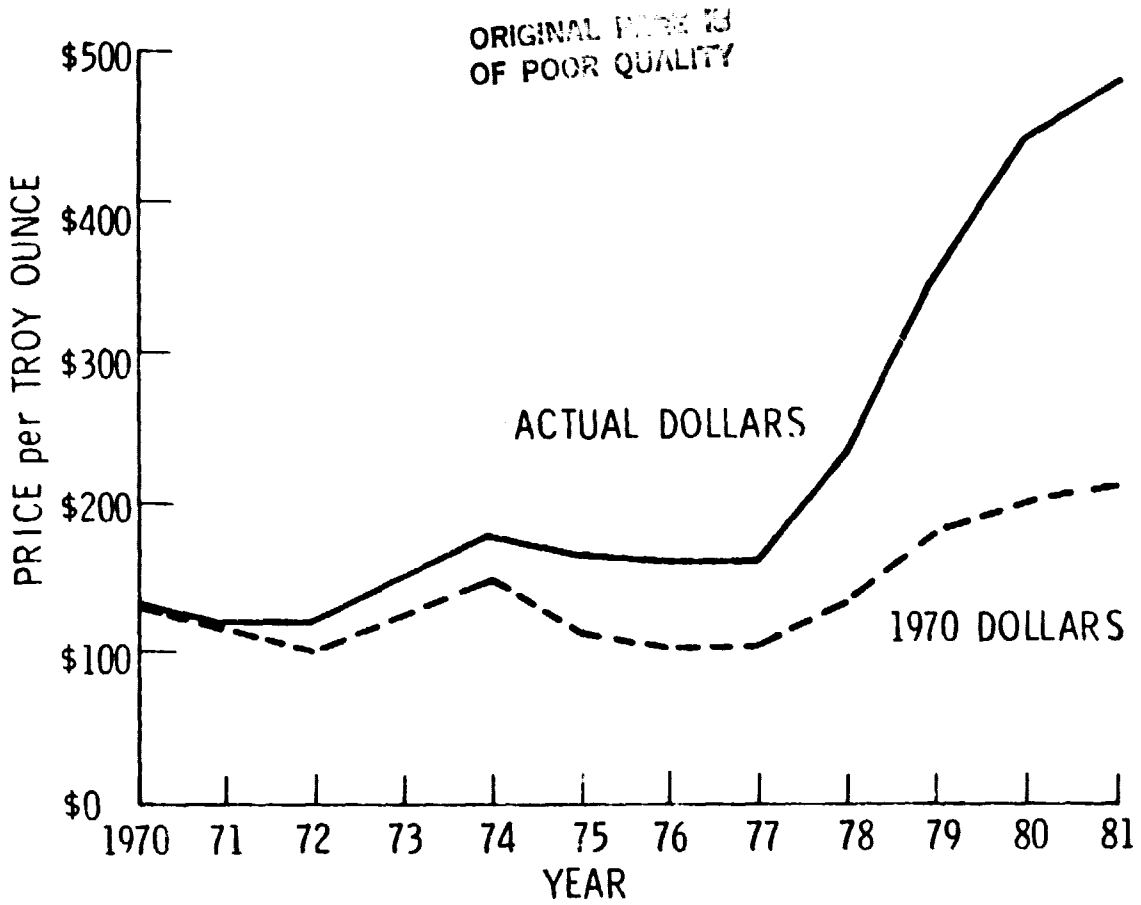

Figure 2-11. Price of Platinum in Actual and Constant Dollars, 1970-1981 (Ref. 2-16)

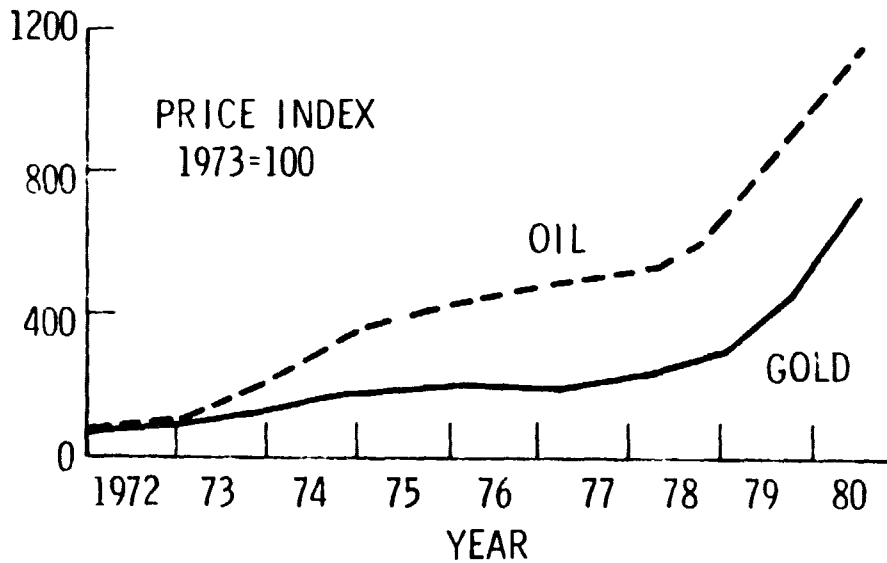

Figure 2-12. Price Trends of Gold and Oil, 1970-1980 (Ref. 2-23)

2.5 PLATINUM MARKET SUMMARY

The following important points regarding the platinum market are distilled from the preceding discussion and re-emphasized:

- Eighty-eight percent of the world's platinum reserves are located in the Republic of South Africa.
- Although the United States has very small platinum reserves, it has very large platinum resources; at least one resource area is being seriously studied for possible development.
- Of the total world production of primary platinum in 1978, 65 percent was marketed by South Africa and 28 percent was marketed by the Soviet Union.
- The world production of platinum has risen substantially during the past decade, and platinum producers are continuing to expand their production facilities.
- The PGM ratio varies from one PGM deposit to another; but since the ratio is generally constant within a given deposit, increased PGM production to meet higher demand for one metal can oversupply and imbalance the markets of other metals.
- Only the Republic of South Africa currently mines platinum as a primary product; the platinum production rates of other producing countries are closely tied to their copper and nickel production rates.
- The United States is a major platinum consumer and imported 47 percent of the world's production of primary platinum in 1978. U.S. platinum imports increased greatly during the 1970s, while U.S. platinum exports remained constant.
- Much of the platinum used in domestic petroleum, chemical, and glass industries is recovered and recycled. The platinum in automobile catalytic converters is not currently recycled; it is estimated catalytic converter recycling could provide 300,000 troy ounces of platinum per year.
- Private industry and the federal government each holds the equivalent of about a four-month domestic supply of platinum in reserve. The industry reserves are readily available for use on demand, but government stockpiles are held for emergency use only and most of them are not in usable forms for industry.
- Seventy percent of all platinum used in the U.S. is for catalytic purposes. The automobile industry consumes nearly half of the total U.S. platinum demand. Other major users include the electronics, petroleum refining, and chemical industries.

- New uses are being developed for platinum in such fields as metallurgy, electronics, medicine, energy production, transportation, and pollution control.
- Recent forecasts agree that platinum demand by the United States and by the world will continue to grow for the remainder of the century. This growth rate will be highest during the 1980s and will gradually shrink during the 1990s.
- The United States is forecast to demand 24.3 million troy ounces of primary platinum during 1978-2000; the world is forecast to demand 75.7 million troy ounces of primary platinum during this period.
- The domestic chemical and jewelry industries are expected to expand their demand for platinum during the next 20 years, while the domestic automobile and petroleum refining industries are expected to reduce their demand over the same period.
- It is generally assumed that platinum producers will be capable of expanding their platinum production to match increasing world demand.
- After remaining fairly steady for more than two decades, the producer price of platinum began a steep increase in 1977 that lasted until 1980 when it again leveled out at \$475/tr. oz.

2.6 REFERENCES

- 2-1. U.S. Bureau of Mines, Mineral Facts and Problems, Bulletin 671, 1980 Edition.
- 2-2. National Research Council, National Materials Advisory Board, Supply and Use Patterns for the Platinum-Group Metals, PB80-179038, 1980.
- 2-3. U.S. Geological Survey, Principles of a Resource/Reserve Classification for Minerals, Circular 831, 1980.
- 2-4. U.S. Bureau of Mines, Minerals Yearbook, Vol. I, 1981.
- 2-5. U.S. Bureau of Mines, Mineral Commodity Summaries, 1982.
- 2-6. U.S. Bureau of Mines, Minerals Yearbook, Vol. I, 1980.
- 2-7. Maxwell, K.W., "Meeting the Increasing Demand," Platinum Metals Review, January 1982.
- 2-8. Maimoni, A., "How Vulnerable Are U.S. Sources of Strategic Materials?" Energy Technology Review, Lawrence Livermore National Laboratory, February 1982.

ORIGINAL PAGE IS
OF POOR QUALITY

- 2-9. Harrison, B., "Control of Nitrogen Oxide Emissions from Automobile Engines," Platinum Metals Review, January 1981.
- 2-10. Chaston, J.C., "The Growing Industrial Use of the Platinum Metals," Platinum Metals Review, January 1982.
- 2-11. Council on Environmental Quality and the U.S. Department of State, The Global 2000 Report to the President, Volume Two: The Technical Report, 1980.
- 2-12. U.S. Bureau of Mines, Mineral Facts and Problems, Bulletin 671, 1975 Edition.
- 2-13. Malenbaum, W.; World Demand for Raw Materials in 1985 and 2000, McGraw-Hill Inc., 1978.
- 2-14. American Metal Market, Metal Statistics 1975, 1975.
- 2-15. American Bureau of Metal Statistics, Inc., Non-Ferrous Metal Data 1980, New York, 1981.
- 2-16. Cleare, M.J., Platinum Availability and Its Overall Cost Contribution in Electrocatalytic Systems, Johnson Matthey Research Centre, May 1982.
- 2-17. American Metal Market, Metal Statistics 1976, 1976.
- 2-18. American Metal Market, Metal Statistics 1977, 1977.
- 2-19. American Metal Market, Metal Statistics 1978, 1978.
- 2-20. American Metal Market, Metal Statistics 1979, 1979.
- 2-21. American Metal Market, Metal Statistics, 1980, 1980.
- 2-22. American Metal Market Newspaper, Vol. 90, No. 147, July 30, 1982.
- 2-23. Board of Governors, Federal Reserve System, Federal Reserve System, Vol. 68, No. 8, August 1982.

3. PLATINUM DEMAND OF PAFC COMMERCIALIZATION

This section presents projections of the quantity of platinum catalyst demanded by PAFC power plant commercialization to the year 2000. Projections are based on assumed platinum use rates and market penetration levels. They account for platinum recovery and reuse. Projections are made for PAFC commercialization in both the U.S. and worldwide generation markets.

The following discussion describes the bases for assuming future PAFC platinum use rates and market penetration levels. These two factors are then combined to achieve forecasts of cumulative PAFC platinum demand to the year 2000.

3.1 PAFC PLATINUM USE RATES

As described in Section 1, PAFC power plants utilize the catalytic properties of platinum to facilitate electrochemical reactions in the anodes and cathodes of the fuel cell stacks. The platinum catalyst, present as dispersed crystallites on carbon supports, promotes the oxidation of hydrogen molecules into hydrogen ions and electrons at the anode, and the reduction of oxygen molecules at the cathode. Platinum is currently the preferred catalyst material due to its high exchange current densities and its resistance to oxidation and dissolution under acidic and high-temperature operating conditions. Platinum can be poisoned by sulfur and carbon monoxide impurities in the fuel, but this problem is minimized by desulfurizing the fuel and operating the fuel cell stack at temperatures high enough (190°C) to restrict poisoning by carbon monoxide.

All prototype PAFC power plants currently under development use platinum as the fuel cell stack catalyst. The rates at which platinum is required by the power plants, in terms of quantity per unit of power output capacity, vary according to power plant application and manufacturer. These platinum use rates are further discussed below. A number of factors could affect the future platinum use rates of PAFC power plants. These factors include platinum application techniques, the use of platinum alloys and substitutes for platinum, platinum catalyst recovery and reuse, fuel cell operating variables, and fuel cell material and design variables. Each of these factors has the potential to reduce the platinum demand rate of PAFC power plants; some could even eliminate the demand for platinum entirely. Research and development activities concerning each factor will be reviewed in order to gain insight into the potential for reducing platinum use in the fuel cell stack. The potential use of other PGMs, such as palladium, as fuel cell catalysts will also be reviewed. By combining the platinum use reduction influences of all factors, the discussion of use rates will conclude with the development of a range of plausible PAFC platinum use rates for future PAFC power plants.

Prototype PAFC power plants use a variety of metallic catalysts in their air preprocessing and fuel processing subsystems. These catalysts include nickel, copper, and platinum. The use of platinum as a catalyst in

ORIGINAL PAGE IS OF POOR QUALITY

the fuel system is restricted, however, because of platinum's sensitivity to impurities such as sulfur and carbon monoxide. The amount of platinum used in the fuel system is, in general, much smaller than the total amount of platinum used throughout the fuel cell stack; hence, its contribution to total PAFC platinum demand will not be considered. In the United Technologies Corporation 40 kW fuel cell power plant, for example, platinum catalysts in the fuel system are found only in the hydrogenator, where they promote the saturation of olefinic hydrocarbons.

3.1.1 Platinum Use Rates of Early PAFC Power Plants

The amount of power that a fuel cell of a given size is capable of generating (its power density) is determined by a variety of physical and operational characteristics, in addition to the quantity of platinum catalyst contained by the fuel cell. The performance curve of a fuel cell (current density vs. cell potential) is a function of cell temperature, cell pressure, reactant composition and utilization, and fuel impurity levels. Increasing the operating temperature of the fuel cell will enhance mass transfer, increase the reaction rates, and usually decrease cell resistance, thus reducing polarization and increasing cell performance. Deleterious performance effects can result from too high an operating temperature, however. These effects include increased corrosion, catalyst sintering and recrystallization, and electrolyte loss due to evaporation. Operating a fuel cell at elevated pressures will improve cell performance by promoting increased reactant partial pressures and high gas solubilities in the electrolyte. Decreasing fuel and oxidant utilization, or inlet concentrations, results in decreased cell performance. Fuel impurities, such as carbon monoxide, sulfur, and nitrogen compounds, will decrease cell performance by poisoning the fuel cell catalyst and altering the chemical composition of the electrolyte (Ref. 3-1).

The early commercial PAFC power plants of the three fuel cell manufacturers [United Technologies Corporation (UTC), Westinghouse Electric Corporation/Energy Research Corporation (W/ERC), and Engelhard Industries] are projected to differ in several key operational parameters that affect fuel cell power density. Therefore, despite the fact that the early commercial PAFC power plants of these three manufacturers are expected to contain similar amounts of platinum per unit of cell area (about 0.75 mg of platinum per square centimeter of cell area), the power densities of these power plants are projected to be significantly different from one another. This means that early commercial PAFC power plants will differ in their power output per unit of platinum loading.

The projected characteristics of early commercial PAFC power plants are displayed in Table 3-1. All four power plants have projected platinum loadings of 0.75 mg/cm²; however, the large multimegawatt power plants use less platinum per watt of power output capacity because of their higher power densities. These higher power densities are at least partly attributable to the operation of multimegawatt power plants at elevated pressures. The large size of these power plants affords greater design flexibility that, in turn, permits achievement of higher power densities and lower platinum use rates. The power density of the fuel cell is, of course,

Table 3-1 Projected Characteristics of Early Commercial Power Plants^a (Ref. 1-2)

	UTC Electric Utility	UTC On-Site	W/ERC Electric Utility	Engelhard On-Site
Rated electrical power output ^b	10 MW	300 kW	7.5 MW	100 kW
Fuel	Natural gas or naphtha	Natural gas	Natural gas or naphtha	Methanol
Electrical efficiency (%)	41	40	40	41
Pressure, $N/m^2 \times 10^3$ (psia)	690-828 (100-120)	101 (14.7)	414-483 (60-70)	101 (14.7)
Temperature, K ($^{\circ}F$)	491 (425)	477 (400)	477 (400)	477 (400)
Acid addition	Not required	Not required	Required	Required
Cooling method ^c	Liquid (2 phase water)	Liquid (2 phase water)	Air	Liquid (dielectric fluid)
Heat recovery	Possible with minor modifications	Available	Customer option	Available
Cell size, m^2 (ft^2)	0.92 (10)	0.34 (3.7)	0.12 (1.25)	0.18 (2)
Power density ^d , W/m^2 (W/ft^2)	1793 (165)	1413 (130)	2500 (230)	978 (90)
Pt loading ^e , mg/cm^2	0.75	0.75	0.75	0.75
Pt loading, mg/W	4.22	5.36	3.03	7.74

^a All characteristics are subject to change as a result of technology improvements, further study, and changes in customer requirements.

^b Other power plant sizes will be produced as the market matures.

^c Two phase water cooling generates steam for reforming directly.

^d Design power density is selected based on tradeoff between heat rate and capital cost; power density is based on dc power output of stack.

^e Approximately 2/3 of catalyst for cathode, 1/3 for anode (in addition to platinum, the cathode contains some vanadium).

only one of many factors of concern in the design of a PAFC power plant, and differences in power density will exist even among designs of the large electric utility PAFC power plants. This is verified by the power density projections for UTC and W/ERC 7.5 MW electric utility power plants in Table 3-1. The W/ERC 7.5 MW power plant will be designed to achieve a relatively high power density of 2500 W/m² with a correspondingly low platinum loading rate of 3.03 mg/W. The UTC 10 MW power plant design, on the other hand, will have a lower power density of 1793 W/m² and a correspondingly higher platinum loading rate of 4.22 mg/W.

The power densities of multikilowatt PAFC power plants for on-site applications are usually less than those of the larger electric utility PAFC power plants because the on-site power plants operate at ambient pressures and have other design and operation restrictions stemming from their size and the nature of their application. The UTC 300 kW power plant is projected to have a power density of 1413 W/m² and a platinum loading rate of 5.36 mg/W, while the Engelhard 100 kW power plant is projected to have a power density of 978 W/m² with a platinum loading rate of 7.74 mg/W. Once again, different design approaches by the fuel cell manufacturers will result in varying power density and platinum use characteristics even among PAFC power plants of a similar power output class.

3.1.2 Research Activities

Fuel cell researchers are seeking to improve many aspects of PAFC power plant design, materials, and operation. Researchers on a number of projects are looking specifically at ways to optimize the use of platinum catalysts in the fuel cell. Research targets include development of: (1) innovative platinum loading techniques to increase platinum's catalytic activity, (2) platinum alloys that will permit a reduction in platinum use with little or no sacrifice in performance, and (3) catalyst substitutes that will eliminate the need for platinum while achieving a comparable level of performance. Personnel on other research projects are investigating methods of improving the physical properties of various cell components to permit operation at higher temperatures and pressures. This could lead to increases in fuel cell power densities and related decreases in platinum loading rates. Development of efficient and economical platinum catalyst recovery techniques would bolster the percentage of fuel cell catalyst that is recovered and reused, and would thereby reduce the demand for replacement catalysts. The following discussion reviews the progress of research activities striving to reduce the platinum use rate of PAFC power plants.

Platinum Loading - The platinum catalyst is applied to the fuel cell electrodes in the form of small crystallites. The small size of these platinum crystallites increases the surface area of platinum available for catalytic reactions. State-of-the-art fuel cell technology disperses the crystallites on highly conductive carbon supports. The application of the catalyst to the carbon supports, and the subsequent application of the

supports to the electrodes, is achieved by using a colloidal mixture of platinum and carbon powders. The colloidal mixture ensures small crystallite size and a uniform distribution of the catalyst. With this method of application, it has been possible during the past 15 years to achieve a 40-fold reduction in the quantity of platinum loading required for cell operation (Ref. 3-3).

Existing platinum loading levels are approximately 0.25 mg/cm^2 on the anode and 0.50 mg/cm^2 on the cathode. Research is attempting to determine whether this catalyst load is being utilized completely, and if not, whether further reductions in platinum loading rates are possible. Stonehart Associates, under contract to NASA, is studying fuel cell reaction rates with various catalyst particle densities. The overall objective of this electrocatalysis program is to define the feasibility of lowering the electrocatalyst cost and increasing the activity. Researchers on current tasks have attempted to separate the influences of electrode structure, catalyst activity, and carbon support material on electrode behavior. The initial interpretation of results is that the present good electrode structures permit far less than 50 percent of the platinum to be used efficiently.

Stonehart Associates assumed that for a given particle size, the reaction rate should correspond to catalyst particle density. Therefore, if the catalyst particle density increases manifold (the catalyst active area increases manifold), a concomitant increase in the reaction rate should also be observed. If the reaction rate does not increase by the multiple of the catalyst surface area, then reactant gas diffusion limitations are suspected and catalyst utilization is incomplete.

Stonehart Associates determined specific reaction rates on anodes with low platinum loadings (0.05 mg/cm^2) and compared them with the reaction rates of anodes having higher platinum loadings (0.5 mg/cm^2). It was found that the current densities of the low-loaded anodes were nearly as high as the current densities of the high-loaded anodes. It was also discovered that the current densities of intermediate-loaded anodes (0.20 mg/cm^2) should have been at least two or three times greater than was actually recorded. It was concluded that catalyst utilization at the anode is less than 30 percent for a 0.20 mg/cm^2 loading and less than 10 percent for a 0.50 mg/cm^2 loading. It is postulated that the same catalyst utilization levels will be obtained at the cathodes for the same catalyst loadings (Ref. 3-4).

These results indicate that improvement is possible in catalyst utilization. Apparently, improvement can be realized by increasing the solubility and diffusivity of the reacting gas molecules in the electrolyte environment, or alternatively, by more efficiently applying the platinum load to the electrodes. Reductions of platinum loading rates by a factor of 2 or 3 are conceivably possible in both the anode and cathode. Further studies may provide information on the location of platinum crystallites in the electrode structures that can be used to modify both the catalyzation procedures and electrodes fabrication methods.

ORIGINAL DOCUMENT
OF POOR QUALITY

ORIGINAL PAGE IS
OF POOR QUALITY

DOE- and Electric Power Research Institute (EPRI)-funded research programs are investigating concepts that may reduce the decay rate of the platinum catalytic activity or may lead to higher catalytic activity than the standard platinum catalyst. The major reasons for activity decay appear to be loss of platinum surface area and corrosion of the carbon support. In the high temperature environment of the fuel cell, the platinum crystallites are sintered into larger masses and thereby lose surface area and catalytic activity. Corrosion of the support may accelerate the rate of surface area loss as well as cause "flooding" of the gas pores in the catalyst layer (Ref. 3-3).

Recent research has successfully identified a number of carbon black support materials that have much better corrosion resistance than the carbon supports in current usage. One of the best materials so far identified is steam-treated acetylene black. It has the high surface area needed for accepting the platinum crystallites, and yet its corrosion rate is about 1 percent of that of conventional carbon black supports. Although the interaction of the support with platinum is not fully understood, support characteristics may be improved by chemically etching the support material to remove corrodable material and developing additional surface area. The etching of "trap sites" for platinum crystallites into the support material could retard the sintering mechanism and reduce the activity decay rate (Ref. 3-5).

Platinum Alloys - Several research organizations are pursuing concepts to improve the performance and cost of fuel cell catalysts by alloying the platinum with other materials. The emphasis for PAFC catalyst technology has been platinum on carbon supports for both the anode and cathode. The emphasis for future catalyst development will be on substituting for the platinum with equally active but lower cost materials. The characteristics needed for anode catalysts are considerably different from those needed for cathode catalysts, particularly when alloys or intermetallic compounds are being considered. Anode catalysts that have a high activity for hydrogen oxidation in the presence of catalyst poisons may be unstable or inactive for oxygen reduction in the cathode.

The most promising catalysts developed for cathodes by past investigations are noble metal-refractory intermetallics. The noble metals have been either platinum or palladium. Refractory metals have been from the carbide-forming refractory metals, principally zirconium, hafnium, vanadium, niobium, and tantalum. Intermetallics so far reported, VPt_3 and $TaPt_5$ have shown promising results. They have outperformed platinum for oxygen reduction in phosphoric acid and in the process have not corroded significantly.

The most important consideration for the anode catalyst is that it be capable of oxidizing hydrogen in the presence of carbon monoxide. In the past, platinum and other PGMs have been alloyed together or with other materials in attempts to improve the performance and cost of anode

catalysts. Alloys of platinum and rhodium have shown increased activity over that of platinum alone, but during extended operation, the rhodium removed itself from use by segregating to the insides of the alloy crystallites. Platinum-ruthenium alloy combinations were also examined but showed little benefit. Alloys of palladium and gold have produced active catalysts resistant to carbon monoxide, but their development has not been pursued due to other shortcomings.

Lawrence Berkeley Laboratory (LBL) has conducted extensive work on the crystallite size effect of platinum catalysts, and in particular, on the morphology of platinum clusters and the relation between surface structure and the kinetics of oxygen reduction. Results show that there is a negative crystallite size effect for oxygen reduction with supported platinum at elevated temperatures. This indicates that there is little benefit to dispersion of platinum below a crystallite size of about 2 nm. This crystallite size effect appears to be an intrinsic property of small ensembles of platinum atoms. Photoelectron spectroscopy studies by LBL suggest, however, that alloying platinum with other metallic constituents will alter the electronic state of these small platinum clusters and could improve their catalytic activity (Ref. 3-3).

LBL has studied a variety of platinum alloy catalysts, particularly platinum with titanium, zirconium, hafnium, vanadium, niobium, and tantalum. Preparation as dispersed bimetallic clusters of uniform composition is required and is difficult to accomplish in all cases. Platinum-titanium and platinum-vanadium are the easiest to prepare; however, the best results from kinetic studies were obtained with platinum-tantalum. The optimum concentration of base metals appears to be 15 to 20 percent. The LBL catalyst studies demonstrate that on a unit area basis, the platinum-vanadium and the platinum-tantalum catalysts are a factor of 4 to 5 times more active than standard supported platinum catalysts (Ref. 3-3).

Platinum-vanadium catalysts are being evaluated by DOE and EPRI-sponsored research. Initial results indicate a 20 to 30 mV improvement in air cathode potential at 200 mA/cm². This is about the level of improvement expected based on the results of laboratory-scale experiments. The gain in catalytic activity of the platinum in these new catalysts could eventually lead to a halving of the 0.5 mg/cm² platinum loading at the cathode (Ref. 3-3).

Stonehart Associates is also evaluating various platinum alloy catalysts for use in phosphoric acid fuel cells. The overall objective of this catalyst program is to define the feasibility of lowering the catalyst cost and to increase the activity in the fuel cells as a way to increase the commercial viability of fuel cells. A number of catalyst combinations were prepared and characterized. These catalysts were formulated to contain platinum combined with transition metal carbide-forming elements (tungsten, molybdenum, and vanadium) for cathodes and platinum combined with palladium for anodes. These alloys were tested on carbon supports. The performance of the anode catalyst formulations matched the performance of pure platinum catalysts with a decrease in catalyst cost of 50 to 80 percent. The cathode

catalyst formulations demonstrated the potential to improve significantly the current density of the cell per unit of platinum with improved electrode structures (Ref. 3-4).

Platinum Substitutes - A variety of nonplatinum materials are being evaluated for possible use as catalysts in the electrodes of PAFC power plants. It is hoped that substitutes can be found that have stability and activity characteristics equal to or exceeding those of platinum, and in addition, will be tolerant of fuel impurities such as carbon monoxide.

The two primary platinum substitutes being investigated are tungsten alloys and metallic-organics. Cubic alloys of tungsten-titanium carbide have been extensively explored. While titanium carbide itself is inactive as a catalyst, alloys with tungsten have been found to be both active and tolerant of carbon monoxide (Ref. 3-6). However, despite the fact that they are the best metallic nonplatinum materials found thus far, continued research on tungsten alloys has shown them to be useless as cathode catalysts and poor as anode catalysts (Ref. 3-7).

Metallo-organic fuel cell catalysts feature metals linked to organic complexes. These materials are active in cathodes and are relatively inexpensive. Among the more prominent metallo-organic catalysts under development is CoTAA. This catalyst utilizes cobalt as its metal constituent. It has demonstrated a lack of stability in hot acids, but research activities continue to improve its stability. For example, CoTAA was stable only a few hours at room temperature in 1977, but by improving its linkage to the carbon support, the stability has been increased to hundreds of hours at 100°C. Its activity has also been improved by modifying the CoTAA dimer (Ref. 3-7).

The development of nonplatinum fuel cell catalysts does not hold any immediate prospects for replacing the use of platinum in PAFC power plants. The tremendous cost savings that could be realized from the development of a cheap substitute catalyst continue to stimulate research efforts. These efforts may eventually lead to a partial or total phaseout of platinum use in PAFC power plants by any one of a number of possible substitute catalysts.

Energy Conversion Efficiency - Improvements in the energy conversion efficiency of fuel cells (lowering of the heat rate) would likely permit the reduction of stack size per unit of power output and thereby reduce the required amount of platinum catalyst. Electrochemical reaction rates in the fuel cells appear to be greatly influenced by interactions among the catalyzed support, the polytetrafluoroethylene (PTFE) binder-wetproofers on the support, and the electrolyte. A better understanding of the interaction of cell components could raise the fuel cell energy conversion efficiency via improvements in operational factors such as solubility and diffusion of reactants within the cell. Currently, the upper voltage potential limit for fuel cells is about 0.8 volt. Corrosion of carbon supports becomes unacceptable above this potential. Operation at the 0.8 volt limit could increase energy conversion efficiencies to 46 percent. Even higher

efficiencies are possible at higher cell potentials. Achievement of efficiencies of this magnitude are obtainable if corrosion can be further reduced and cell temperature further increased. The possibility of replacing high-surface carbon supports by a more stable material, such as carbides and silicides, is being explored. It also appears probable that new intermetallic catalysts will be sufficiently stable to operate at potentials over 0.8 volt. Replacement of the phosphoric acid electrolyte by less corrosive materials is being evaluated as a method of permitting increases in cell potential while limiting corrosion of both platinum and carbon (Ref. 3-5).

Catalyst Reprocessing - Efficient catalyst reprocessing techniques have been developed over the last two decades. Platinum catalysts are routinely recovered and reused by the chemical and petroleum industries. It is expected that platinum will be recovered from used fuel cell stacks because: (1) it is not as widely dispersed as in automobile catalytic converters, but rather is concentrated in a limited number of stacks; and (2) it is relatively easy to recover from the fuel cell's carbon substrate. An estimated 90 to 95 percent of the platinum catalyst is recoverable from state-of-the-art fuel cell stacks (Ref. 3-7). This recovery rate could be altered by further improvements in recovery techniques or modifications in stack construction. Lengthening stack life will reduce the frequency of stack overhaul and therefore reduce the quantity of platinum lost during reprocessing procedures. For the purpose of estimating PAFC platinum demand, this study assumes that 92 percent of the platinum catalyst in used fuel cells will be recycled during 1985-2000.

3.1.3 Platinum Use Rates of Mature PAFC Power Plants

As described in Section 3.1.1, early commercial PAFC power plants are projected to have a uniform platinum loading rate of about 0.75 mg/cm^2 of cell area (0.50 mg/cm^2 in the anode). The projected power density differences among these power plants give platinum loadings in terms of power capacity of from 3 mg/W to nearly 8 mg/W. The research and development activities described in Section 3.1.2 are attempting to lower these loading rates by increasing the efficiency of platinum use and substituting other suitable catalysts for platinum. In order to forecast the platinum demand of PAFC power plant commercialization, it is necessary to have reasonable estimates of the platinum loading rates of future mature commercial PAFC power plants. In making these estimates, several important R&D trends are borne in mind:

- Intermetallic catalysts of platinum and a refractory metal have outperformed platinum for oxygen reduction in hot phosphoric acid and in the process have not corroded significantly. Tests with these intermetallics, and in particular platinum-vanadium, indicate that the gain in catalytic activity could eventually lead to a halving of the 0.5 mg/cm^2 platinum loading in the cathode (Ref. 3-3).

- Carbon supports interact strongly with platinum and other catalysts. Although this interaction is not fully understood, support characteristics may be improved by several methods such as etching catalyst trap sites into the support and removing corrodable material from the support prior to catalyst application. These techniques could retard platinum sintering and reduce the decay rate of platinum activity (Ref. 3-5).
- Breakthroughs in research on substitute catalysts (e.g., tungsten carbides, metallo-organics) are not foreseeable in the near future and cannot be relied on to reduce or eliminate the need for platinum catalysts in PAFC power plants. Development of these substitutes has been hampered by lack of catalytic activity and stability (Ref. 3-7).

These trends indicate that the platinum loadings of mature commercial PAFC power plants will be less than those projected for early commercial PAFC power plants. Problems in the development of catalytic substitutes indicate that the need for platinum catalysts may not be eliminated entirely; however, a halving of the cathode loading does appear to be realistically possible without decreasing the cell's power density. Improvements in cell components that permit a more efficient use of the catalyst and operation at higher temperatures and pressures would increase the cell's power density and thereby further reduce the loading rate per power output capacity.

Two platinum loading reduction schedules will be assumed for the purposes of this study. Both proposed schedules cover the 1985-2000 time period. The first schedule is considered by NASA-Lewis Research Center fuel cell researchers to be the most likely estimate of the future platinum loading trend. According to this "most probable" schedule, expected breakthroughs in platinum loading technology will permit the reduction of loading from the current rate of 0.75 mg/cm^2 to a new rate of only 0.30 mg/cm^2 by 1990 (Ref. 3-8). The schedule consists, therefore, of a straight-line reduction from 0.75 mg/cm^2 in 1985 to 0.30 mg/cm^2 in 1990, followed by a constant loading of 0.30 mg/cm^2 throughout the 1990s. The second proposed platinum loading schedule is extremely conservative and in fact is considered a "worst case" by NASA-Lewis fuel cell researchers (Ref. 3-8). This schedule also reduces the platinum loading rate but to a much smaller degree. According to this worst case schedule, platinum loading will be reduced on a straight line from 0.75 mg/cm^2 to 0.50 mg/cm^2 over the 1985-2000 time period. Both proposed platinum loading schedules are illustrated in Figure 3-1.

The average of the platinum loadings (in terms of power output) projected for the early commercial UTC and W/ERC electric utility power plants is approximately 3.60 mg/W (see Table 3-1). The average of the loadings projected for the UTC and Engelhard on-site power plants is approximately 6.60 mg/W . If it is assumed that fuel cell power densities remain steady during 1985-2000, the platinum loading decreases of the two proposed schedules will reduce these figures by equivalent percentages. For example, the drop of the first schedule from 0.75 mg/cm^2 to 0.30 mg/cm^2 will reduce the

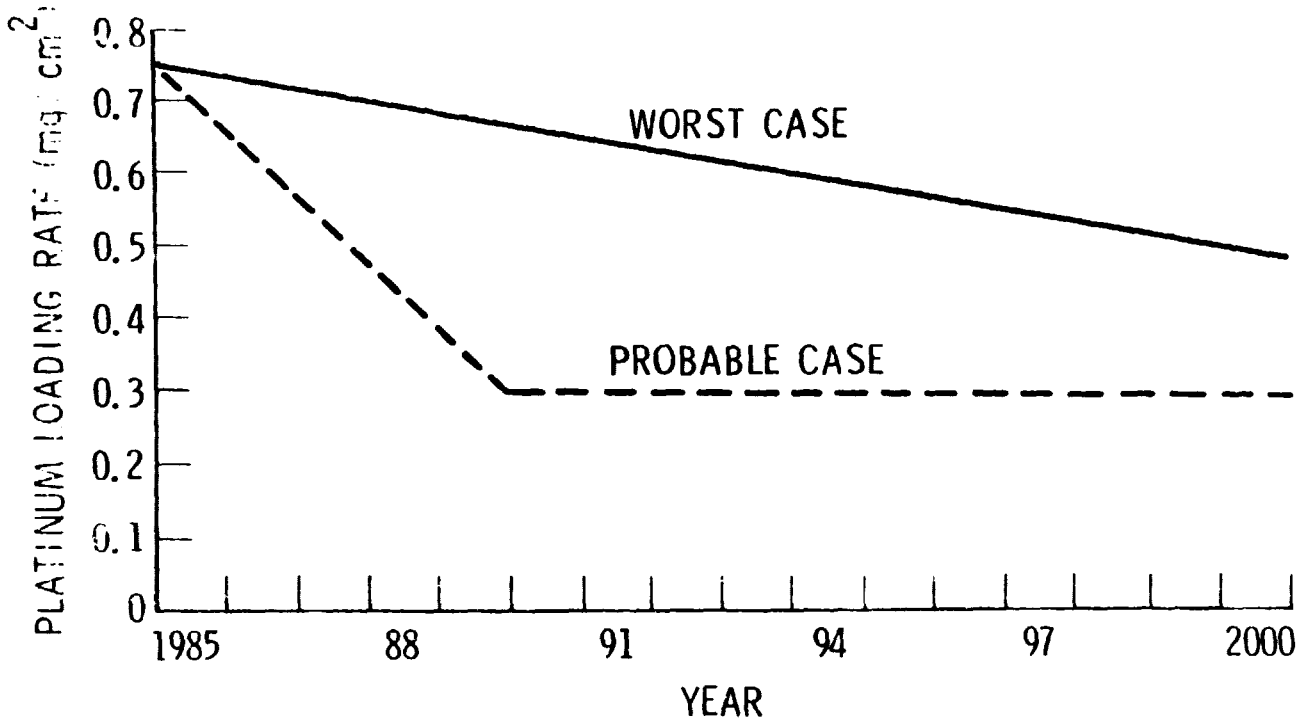

Figure 3-1. Two Platinum Loading Rate Schedules

electric utility power plant rate to 1.44 mg/W and the on-site power plant rate to 2.64 mg/W. These rates will be used in Section 3.3 to determine the platinum demand of PAFC commercialization.

3.2 PAFC MARKET PENETRATION

Numerous studies have been completed during the past five years that have forecast the level of market penetration of both on-site and utility power plants in the United States at a future date, generally the year 2000. Each of these studies is based on a set of assumptions addressing power plant size, fuel availability, financial incentives, and penetration initiation dates. Taken as a whole, these studies have predicted total fuel cell penetration by the year 2000 that range from a high of 400,000 MW to a low of 180,000 MW (Refs. 3-9 through 3-12). However, because of declines in the generation capacity growth rate and delays in the initiation of PAFC commercialization that have occurred since the studies, these forecasts are now regarded as highly optimistic. The current consensus within the fuel cell community is that PAFC penetration in the United States will reach a range of 20,000 to 40,000 MW by the year 2000. This will represent approximately 2 to 4 percent of the total national generation capacity by that date.

PAFC market penetration will be composed of (1) multimegawatt power plants for use by electric utilities and (2) multikilowatt power plants for on-site use at locations such as stores, schools, restaurants, and apartment buildings. Past PAFC market penetration studies have forecast that between 5 and 10 percent of total PAFC penetration will consist of on-site power plants while the remainder will be composed of the larger electric utility power plants. For the purpose of estimating the platinum demand of PAFC commercialization, this study assumes that 10 percent of total PAFC penetration will be accounted for by on-site power plants. As described by Section 3.1, on-site power plants are projected to have higher platinum loading rates than the electric utility power plants. Use of the 10 percent figure for the on-site power plant share of total PAFC penetration will help ensure that the contribution of this higher platinum use rate to total PAFC platinum demand is not underestimated.

The potential market for PAFC power plants is global in scope rather than limited solely to the United States. While global market penetration studies have not been published, significant demand for fuel cell power plants is expected to arise in several areas of the world outside of the United States, most notably Western Europe and Japan. European and Japanese firms are also developing fuel cell power plants and they will vie with U.S. manufacturers for shares of the global fuel cell market. Foreign demand for fuel cell power plants will increase world platinum consumption regardless of where the power plants are manufactured. An analysis of the effects of PAFC commercialization on the platinum market is not complete without an accounting of fuel cell penetration into all global markets.

ORIGINAL PAGE 13
OF POOR QUALITY

Worldwide installed generating capacity can be divided roughly into thirds among (1) the United States, (2) Western Europe and Japan, and (3) the rest of the world. The majority of fuel cell commercialization is expected to be concentrated in the United States, Western Europe, and Japan. Although fuel cell power plants are under development by both European and Japanese companies, the development lead established by U.S. companies will likely result in the penetration by fuel cells of the U.S. electric utility market in advance of foreign electric utility markets. Historically, application of electric utility innovations to the U.S. market has generally preceded their application to the European and Japanese markets by at least five years. In the case of PAFC development, Japanese technology is estimated to be about five years behind the technology of U.S. companies (Ref. 3-13). This study assumes that the onset and growth of foreign market penetration will lag five years behind market penetration in the United States, regardless of whether the foreign markets are penetrated by United States or foreign fuel cell manufacturers. Therefore, assuming that market penetration in Western Europe and Japan proceeds at the same rate as in the United States, but retarded by five years, 20,000 to 40,000 MW of fuel cell capacity would be operational in Western Europe and Japan by the year 2005. Some fuel cell penetration may occur in the utility markets of the third group of countries (communist, Third World, and other western countries), but the volume of this penetration will probably be small compared to penetration in the more concentrated and profitable United States, Western European, and Japanese markets.

This study assumes that PAFC market penetration will commence in the United States in 1985 and in Western Europe and Japan in 1990. Market penetration data from previous studies lead to the formulation and use of the following market penetration growth curve:

$$y = x^{1.3}/1.225$$

where x = number of years of PAFC commercialization
 y = cumulative PAFC market penetration (1000 MW).

This equation has been fashioned to yield the market penetration levels assumed by this study. It yields a total U.S. market penetration of 30,000 MW for the 16-year period of 1985-2000. This total is in the middle of the 20,000 to 40,000 MW penetration range assumed for this study. As previously described, market penetration in the rest of the world (primarily Western Europe and Japan) is expected to have the same overall potential as the U.S. market, but to lag U.S. penetration by five years. Application of the growth equation to the foreign market yields approximately 18,400 MW of PAFC penetration for the period 1990-2000. Combination of the two staggered market penetration curves (U.S. and foreign) yields a total world penetration of approximately 48,400 MW from the outset of commercialization in 1985 through the year 2000.

Yearly and cumulative market penetration figures for the world and U.S. are given in Table 3-2 for the middle of the projected penetration range. The upper and lower ranges of market penetration are obtained by multiplying the

ORIGINAL PAGE 11
OF POOR QUALITY

Table 3-2. Mid-Range Values of Projected Market Penetration^a
(1000 MW)

	United States		Rest of World		World Total	
	<u>Yearly</u>	<u>Cumulative</u>	<u>Yearly</u>	<u>Cumulative</u>	<u>Yearly</u>	<u>Cumulative</u>
1985	0.82	0.82	-	-	0.82	0.82
1986	1.19	2.01	-	-	1.19	2.01
1987	1.39	3.40	-	-	1.39	3.40
1988	1.55	4.95	-	-	1.55	4.95
1989	1.66	6.61	-	-	1.66	6.61
1990	1.77	8.38	0.82	0.82	2.59	9.20
1991	1.86	10.24	1.19	2.01	3.05	12.25
1992	1.95	12.19	1.39	3.40	3.34	15.59
1993	2.01	14.20	1.55	4.95	3.56	19.15
1994	2.09	16.29	1.66	6.61	3.75	22.90
1995	2.14	18.43	1.77	8.38	3.91	26.81
1996	2.21	20.64	1.86	10.24	4.07	30.88
1997	2.27	22.91	1.95	12.19	4.22	35.10
1998	2.31	25.22	2.01	14.20	4.32	39.42
1999	2.37	27.59	2.09	16.29	4.46	43.88
2000	2.41	30.00	2.14	18.43	4.55	48.43

^a

High level of market penetration range is 1.33 times the mean value; low level of range is 0.667 times the mean value.

penetration numbers of Table 3-2 by factors of 1.33 and 0.667, respectively. Figure 3-2 charts the growth in cumulative world and U.S. market penetration from 1985 through 2000 according to mid-range market penetration forecasts.

3.3 FUTURE PAFC PLATINUM DEMAND

The two most important factors in determining the future platinum demand of PAFC power plant commercialization are: (1) the PAFC platinum use rates per unit of installed capacity and (2) the market penetration of PAFC commercialization in terms of newly installed capacity per year. Current PAFC platinum use rates are described in Section 3.1 along with details of research efforts underway to reduce these use rates. Projections of future use rates are based on current use rates and indications of future rate reductions. Section 3.2 addresses the question of future PAFC market penetration. Based on past penetration studies, current informal forecasts, and several assumptions, Section 3.2 projects ranges of market penetration through the year 2000 for both the domestic and global electric generation markets.

Section 3.1 suggests the use of two different PAFC loading rate schedules for 1985-2000 as shown in Figure 3-1. The first schedule is considered a probable loading trend and reduces the current platinum loading rate by 60 percent from 1985 to 1990 (0.75 mg/cm^2 to 0.30 mg/cm^2). This lower rate is then maintained throughout the 1990s. The second schedule is considered to be very conservative because it reduces the loading by only 33 percent over the 1985-2000 time period.

Following the stated assumption that 90 percent of installed PAFC capacity will be in the form of large electric utility power plants and only 10 percent will be in the form of the smaller on-site power plants, composite loading factors can be derived for application to market penetration figures. The projected early commercial loading rate figures of 3.60 mg/W (average of electric utility power plants) and 6.60 mg/W (average of on-site power plants) can be combined to give a composite of 3.90 mg/W . Reducing the composite loading figure of 3.90 mg/W by 60 percent yields a composite figure of 1.55 mg/W for use by the "probable case" schedule in 1990. The conservative or "worst case" schedule reduces the 3.90 mg/W composite by 33 percent to yield a 2.60 mg/W composite for its use in the year 2000.

Section 3.2 formulates a range of market penetration figures for both the U.S. domestic market and the total global market. The penetration forecast for the U.S. market is 20,000 to 40,000 MW by 2000. The forecast range is wide because of the numerous uncertainties currently surrounding PAFC commercialization. Little information is available on market penetration potential of foreign markets. It was assumed that the combined penetration of foreign markets by PAFC power plants will be equivalent to domestic penetration levels but that their onset and magnitude will lag five years behind U.S. penetration. It was further assumed that U. S. market penetration levels will be reached during a 16-year period commencing in

ORIGINAL SOURCE
OF POOR QUALITY

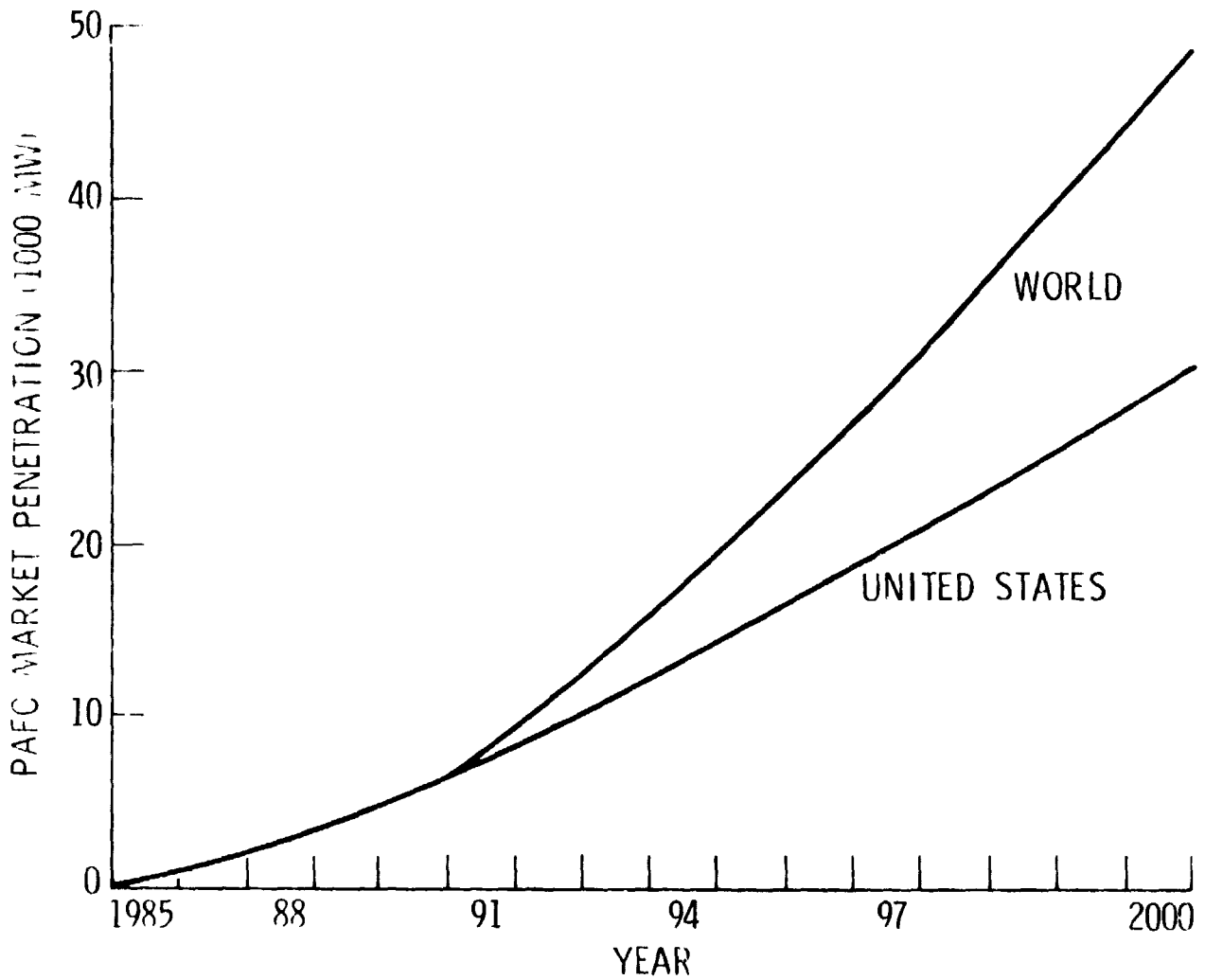

Figure 3-2. Cumulative World and U.S. PAFC Market Penetration, 1985-2000 (middle of forecast range)

ORIGINAL PAGE IS
OF POOR QUALITY

1985 and extending through 2000. The growth of the combined European and Japanese market penetration was assumed to be identical to U.S. penetration except that it will commence in 1990 rather than in 1985 and it will lag the level of U.S. penetration by five years.

The operational life of preprototype fuel cell stacks is approximately 40,000 hours or about five years with near continuous operation. Improvements in stack duration are likely, but the conservative figure of five years will be adopted for this study. At the end of five years of operation, the fuel stack will require removal and reconditioning. Much of the platinum catalyst will be recovered and reused during reconditioning. By use of the 92 percent recovery figures discussed in Section 3.1, about 8 percent of the platinum in PAFC power plants will require replacement every five years. The need to supplement fuel cell catalysts will begin five years following the initiation of commercialization. According to our projected penetration schedule, platinum supplements will be required in the U.S. market beginning in 1990 and in the foreign markets beginning in 1995.

Figures 3-3 and 3-4 combine many of these assumptions into charts of cumulative PAFC platinum demand for the probable and worst case platinum loading schedules, respectively. Each chart plots two platinum demand ranges for 1985-2000: one range for the United States and the other range for the world including the United States. As reflected by these charts, U.S. and world PAFC platinum demands are synonymous until 1990, at which time foreign PAFC commercialization boosts total world demand above U.S. demand.

Table 3-3 provides comprehensive platinum demand data for the probable case platinum loading schedule. The platinum demand numbers in Table 3-3 apply to the middle level of the probable case range which corresponds to market penetration levels of 30,000 MW in the United States and 48,400 MW in the world by the year 2000. The highest level of the range is obtained by multiplying the numbers of the middle level by 1.33; the lowest level of the range is obtained by multiplying the middle level values by 0.667.

Table 3-3 divides PAFC platinum demand into demand by the United States demand by the rest of the world, and demand by the entire world, including the United States. Each of these groupings is split into four columns of numbers: (1) platinum demanded each year for new PAFC power plant installations, (2) platinum demanded each year for "topping off" recycled fuel cell stacks, (3) the total yearly platinum demand of the first two columns, and (4) the cumulative platinum demand induced by PAFC commercialization up through the given year. The negative numbers in the recycle columns indicate that more platinum was recovered from the used stacks than was required by the reconditioned stacks. This situation results from the large drop in the loading rate during the five years of stack operation. For example, Table 3-3 shows that when fuel cell stacks installed in 1985 (820 MW) are recycled in 1990 (five-year stack life), an excess of 53,730 troy ounces of platinum is produced for use in new fuel cell stacks. This excess is created by recovery of 94,590 troy ounces of

ORIGINAL PAGE IS
OF POOR QUALITY

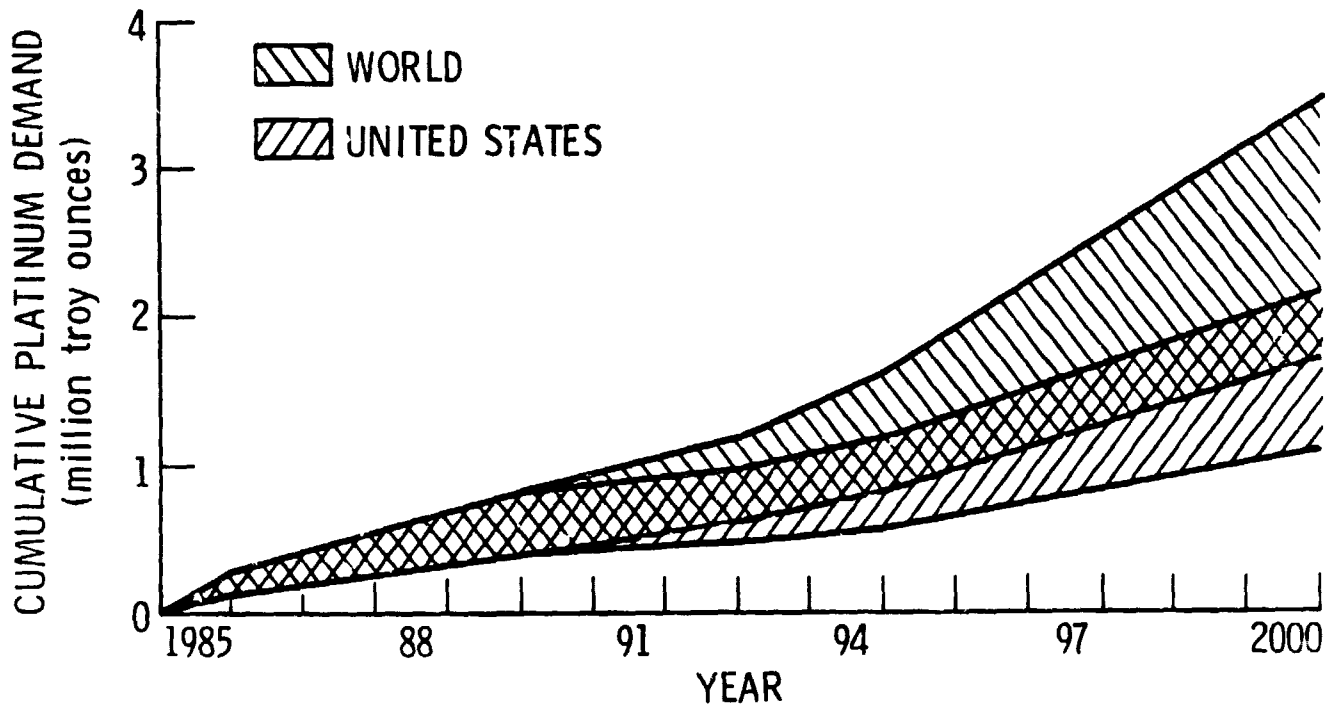

Figure 3-3. Cumulative PAFC Platinum Demand According to Probable Case Loading Schedule

ORIGINAL COSTS
OF POOR QUALITY

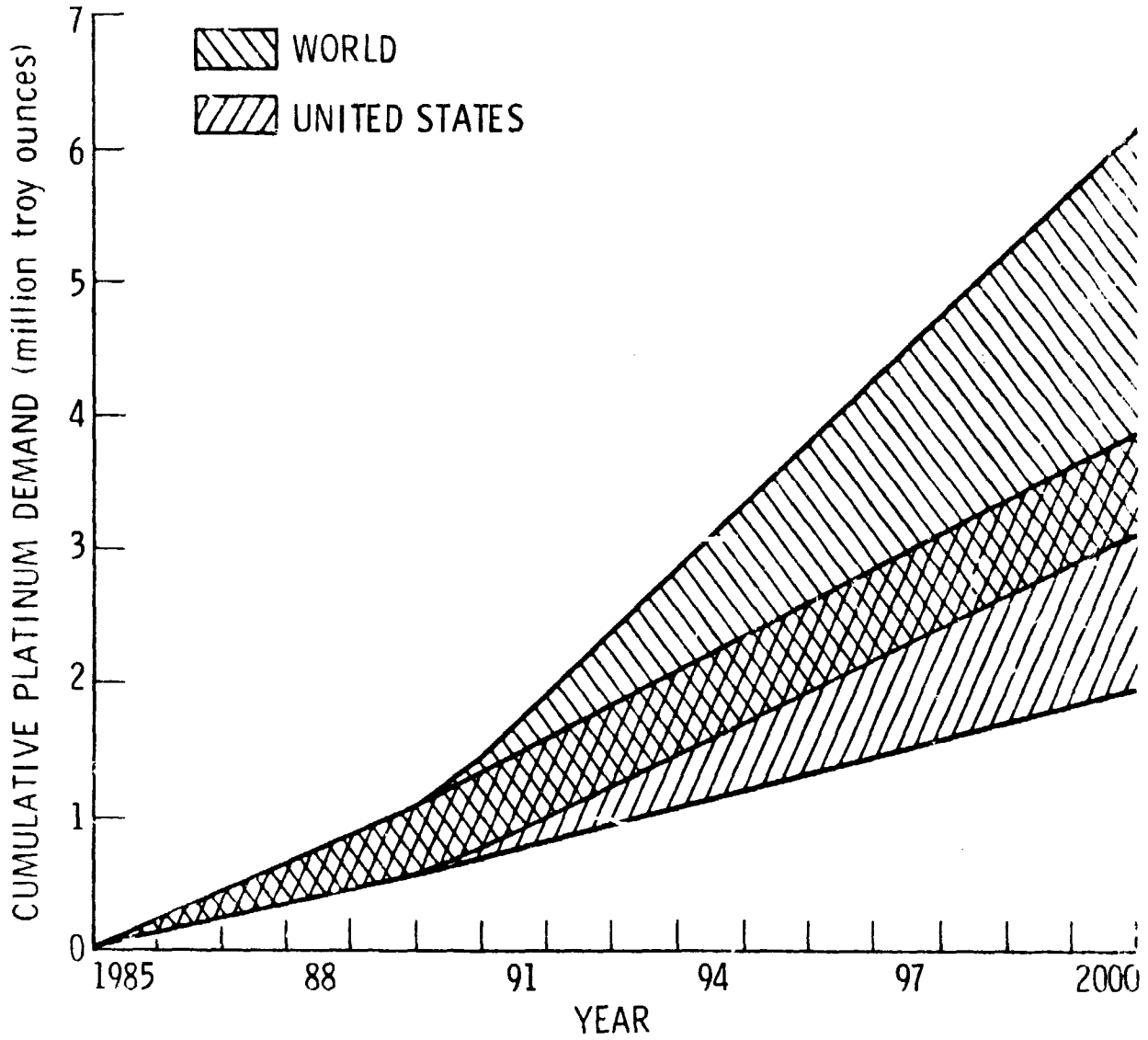

Figure 3-4. Cumulative PAFC Platinum Demand According to Worst Case Loading Schedule

Table 3-3. Middle of PAFC Platinum Demand Range
According to Probable Case Loading Schedule
(1000 troy ounces)

Year	Loading Rate (kg/MW)	New	United States			Rest of World				World Total			
			Recycle	Total	Cum.	New	Recycle	Total	Cum.	New	Recycle	Total	Cum.
1985	3.90	102.82	--	102.82	102.82	--	--	--	--	102.82	--	102.82	102.82
1986	3.43	131.23	--	131.23	234.05	--	--	--	--	131.23	--	131.23	234.05
1987	2.96	132.28	--	132.28	366.33	--	--	--	--	132.28	--	132.28	366.33
1988	2.49	124.08	--	124.08	490.41	--	--	--	--	124.08	--	124.08	490.41
1989	2.02	107.81	--	107.81	598.22	--	--	--	--	107.81	--	107.81	598.22
1990	1.55	88.20	-53.73	34.47	632.69	40.86	--	40.86	40.86	129.06	-53.73	75.33	673.55
1991	1.55	92.69	-61.43	31.26	663.95	59.30	--	59.30	100.16	151.99	-61.43	90.56	764.11
1992	1.55	97.17	-52.44	44.73	708.68	69.27	--	69.27	169.43	166.44	-52.44	114.00	878.11
1993	1.55	100.16	-36.91	63.25	771.93	77.24	--	77.24	246.67	177.40	-36.91	140.49	1018.60
1994	1.55	104.15	-16.47	87.68	859.61	82.72	--	82.72	329.39	186.87	-16.47	170.40	1189.00
1995	1.55	106.64	10.33	116.97	976.58	88.20	3.26	91.46	420.85	194.84	13.59	208.43	1397.43
1996	1.55	110.13	12.16	122.29	1098.87	92.69	4.74	97.43	518.28	202.82	16.90	219.72	1617.15
1997	1.55	113.12	13.32	126.44	1225.21	97.17	5.54	102.71	620.99	210.29	18.86	229.15	1846.30
1998	1.55	115.11	14.15	129.30	1354.61	100.16	6.18	106.34	727.33	215.27	20.37	235.64	2081.94
1999	1.55	118.10	14.95	133.05	1487.66	104.15	6.62	110.77	838.10	222.25	21.57	243.82	2325.76
2000	1.55	120.10	18.86	138.96	1626.62	106.64	10.32	116.96	955.06	226.74	29.18	255.92	2581.68

Table 3-4. Middle of PAFC Platinum Demand Range
According to Worst Case Loading Schedule
(1000 troy ounces)

Year	Loading Rate (kg/MW)	New	United States			Rest of World				World Total			
			Recycle	Total	Cum.	New	Recycle	Total	Cum.	New	Recycle	Total	Cum.
1985	3.90	102.82	--	102.82	102.82	--	--	--	--	102.82	--	102.82	102.82
1986	3.81	145.76	--	145.76	248.58	--	--	--	--	145.76	--	145.76	248.58
1987	3.73	166.69	--	166.69	415.27	--	--	--	--	166.69	--	166.69	415.27
1988	3.64	181.39	--	181.39	596.66	--	--	--	--	181.39	--	181.39	596.66
1989	3.55	189.46	--	189.46	786.12	--	--	--	--	189.46	--	189.46	786.12
1990	3.47	197.46	-3.11	194.35	980.47	91.48	--	91.48	91.48	288.94	-3.11	285.83	1071.95
1991	3.38	202.12	-4.79	197.33	1177.80	129.31	--	129.31	220.79	331.43	-4.79	326.64	1398.59
1992	3.29	206.26	-6.32	199.94	1377.74	147.03	--	147.03	367.82	353.29	-6.32	346.97	1745.56
1993	3.21	207.44	-6.92	200.52	1578.26	159.96	--	159.96	527.78	367.40	-6.92	360.48	2106.04
1994	3.12	209.64	-7.79	201.85	1780.11	166.51	--	166.51	694.29	376.15	-7.79	368.36	2474.40
1995	3.03	208.47	-13.52	194.95	1975.06	172.42	-4.28	168.14	862.43	380.89	-17.80	363.09	2837.49
1996	2.95	209.60	-15.65	193.95	2169.01	176.41	-6.11	170.30	1032.73	386.01	-21.76	364.25	3201.74
1997	2.86	208.72	-17.91	190.81	2359.82	179.30	-7.46	171.84	1204.57	388.02	-25.37	362.65	3564.39
1998	2.77	205.72	-20.97	184.75	2544.57	179.00	-9.12	169.88	1374.45	384.72	-30.09	354.63	3919.02
1999	2.68	204.20	-22.95	181.25	2725.82	180.08	-10.16	169.92	1544.37	384.28	-33.11	351.17	4270.19
2000	2.60	201.45	-28.52	172.93	2898.75	178.88	-15.62	163.26	1707.63	380.33	-44.14	336.19	4606.38

platinum from the used stacks (92 percent of 102,820 troy ounces) and raising only 40,860 troy ounces in the replacement stacks. The reduction in platinum use by the 820 MW of installed capacity is caused by the drop in the platinum loading rate from 3.90 kg/MW in 1985 to 1.55 kg/MW in 1990.

According to the probable case loading schedule, PAFC commercialization during 1985-2000 will demand a cumulative amount of platinum in the U.S. equal to 1,626,620 troy ounces. This demand could range as high as 2,168,000 troy ounces or as low as 1,084,000 troy ounces. Cumulative PAFC demand for the entire world, including the United States, is projected by Table 3-3 to be 2,581,680 troy ounces during 1985-2000 with a range of from 1,721,000 to 3,442,000 troy ounces.

As shown by Table 3-4, the platinum demands induced by the worst case loading schedule are significantly higher than the demands induced by the probable case loading schedule. Cumulative worst case demand for the United States through 2000 is projected to be 2,898,750 troy ounces with a range from a low of 1,932,000 troy ounces to a high of 3,864,000 troy ounces. For the entire world, the cumulative demand is projected to be 4,606,380 with a range of from 3,071,000 to 6,142,000 troy ounces.

Table 3-5 summarizes the cumulative platinum demand ranges of the two loading schedules for both the U.S. and the entire world including the United States. Actual domestic consumption could be higher if domestic fuel cell manufacturers capture a share of the foreign PAFC market.

Table 3-5. Cumulative Platinum Demands
of PAFC Commercialization During 1985-2000
(troy ounces)

Penetration Level by Year 2000	Loading Level	
	Probable Case	Worst Case
World		
High (64,560 MW)	3,442,000	6,142,000
Medium (48,430 MW)	2,581,680	4,606,380
Low (32,280 MW)	1,721,000	3,071,000
United States		
High (40,000 MW)	2,168,000	3,864,000
Medium (30,000 MW)	1,626,620	2,898,750
Low (20,000 MW)	1,084,000	1,932,000

ORIGINAL COPY IS
OF POOR QUALITY

3.4 CONCLUSIONS

This section has assumed PAFC platinum loading rate schedules and market penetration curves and has combined the two to forecast the amount of platinum demanded by PAFC commercialization to the year 2000. Because of the many uncertainties surrounding future PAFC technology and marketing, numerous study assumptions were required. These assumptions are based on existing fuel cell information and include:

- A set of two platinum loading rate schedules: (1) a probable case schedule that reduces the loading rate from 3.90 mg/W in 1985 to 1.55 mg/W in 1990 and holds it at 1.55 mg/W throughout the 1990s, and (2) a worst case schedule that reduces the loading rate in even increments from 3.90 mg/W in 1985 to 2.60 mg/W in 2000;
- A PAFC stack life of five years and a platinum recovery rate during stack reprocessing of 92 percent;
- A PAFC penetration into the U.S. utility market of 20,000 to 40,000 MW by 2000; and
- A total PAFC penetration into the utility market of the rest of the world equal to 12,280 to 24,560 MW by 2000; this is equivalent to the U.S. penetration growth curve retarded by five years.

Based on these assumptions, it was determined that commercialization of PAFC power plants in the U.S. domestic market will require a cumulative total of between 1.08 and 3.86 million troy ounces of platinum from 1985 to 2000. As displayed in Table 3-5, the wide forecast range results from the use of two different platinum loading rate schedules and a wide range of projected market penetration. The future platinum demand of global PAFC power plant commercialization was determined to be 1.72 to 6.14 million troy ounces from 1985 to 2000.

The cumulative platinum demand of PAFC commercialization is not very sensitive to changes in either the platinum recovery rate or the fuel cell stack life. In the absence of any PAFC platinum recycling, the cumulative platinum demand of 2.52 million troy ounces (Table 3-3) would inflate to 4.52 million troy ounces -- an increase in platinum use of 79 percent. However, small rate changes above or below the assumed 92 percent recovery level will stimulate only relatively minor changes in total PAFC platinum demand. For example, increasing the 92 percent recovery rate to 95 percent will decrease PAFC platinum demand by only 2.2 percent during 1985-2000. Shortening the five-year stack life by one year increases PAFC platinum demand by only 1.0 percent during 1985-2000. Lengthening the five-year stack life by one year decreases PAFC platinum demand by only 1.4 percent over the same period.

ORIGINAL SOURCE
OF POOR QUALITY

3.5 REFERENCES

- 3-1. T.G. Benjamin, Camara, E.H., and Marionowski, L.G., Handbook of Fuel Cell Performance, Institute of Gas Technology, May 1980.
- 3-2. G. Bollenbacher (NASA-Lewis Research Center), personal communication, 1981.
- 3-3. P.R. Ross, Jr., Improvements in the Utilization of PT in Phosphoric Acid Fuel Cells, Lawrence Berkeley Laboratory, extended abstract for Spring 1982 ECS Meeting, Montreal, January 1982.
- 3-4. Stonehart Associates, Advanced Electrocatalysts for Primary Phosphoric Acid Fuel Cells, Monthly Technical Status Report No. 22, November 1981.
- 3-5. A.J. Appleby, The Potential for Improvements in Phosphoric Acid Technology, Electric Power Research Institute, June 1981.
- 3-6. A.J. McAlister, Non-Noble Catalysts and Catalyst Supports for Phosphoric Acid Fuel Cells, National Bureau of Standards, Metallurgy Division, November 1980.
- 3-7. M. Warshay (NASA-Lewis Research Center), personal communication, August 1981.
- 3-8. P. Lauver (NASA-Lewis Research Center), personal communication, July 1982.
- 3-10. Burns and McDonnell Engineering Company, An Assessment of the Fuel Cell's Role in Small Utilities, EPRI EM-696, February 1978.
- 3-11. Mathtech, Inc., Venture Analysis Case Study for On-Site Fuel Cell Energy Systems, July 1978.
- 3-12. A.P. Sanghvi, "Framework for Evaluating the Socioeconomic Impacts of Commercializing New Energy Technologies with an Application to the On-Site Fuel Cell Energy System," Energy, Vol. 5, pp 1231-44, 1980.
- 3-13. C. Fujishima, Japanese Research and Development of Fuel Cells, DOE/SF/10538-T6, Galaxy Inc., February 1981.

SECTION 4. PLATINUM MARKET ANALYSIS

This section presents the analyses of the potential impacts of PAFC power plant commercialization on the world platinum market. Platinum demand forecasts of the two previous sections are used to estimate future platinum demand increases prompted by widespread commercialization. The ability of the platinum supply market to furnish increasing quantities of primary platinum is examined, including the adequacy of world platinum reserves and platinum production facilities. The effect that PAFC platinum demand will have on platinum prices is analyzed by characterizing the cartel-like market structure and estimating its probable price response.

Changes in platinum prices alter the cost of the platinum catalysts within the fuel cell stacks and hence the capital costs of the entire power plant. The impact that the market price response to PAFC commercialization will have on the capital costs of PAFC power plants is estimated by considering projections of power plant capital costs and the platinum cost component of these costs. This section concludes with a discussion of the vulnerability of U.S. platinum supplies to disruption, the domestic response to supply disruption, and the possible platinum price and PAFC power plant capital cost repercussions of a supply disruption.

4.1 FUTURE PLATINUM DEMAND

Projections of U.S. and world platinum demands are described in Section 2.3. Figure 2-8 charts the BOM demand forecasts for 1978-2000 and shows the fraction of demand projected to be satisfied with available secondary (recycled) metal. Primary (newly mined) metal is required to satisfy the balance of demand not met by secondary metal. As illustrated by Figure 2-8, the majority of platinum demand will continue to be met by primary metal although the percentage met by secondary metal is projected to increase worldwide from 12 percent in 1978 to 19 percent in 2000.

Platinum demand increases prompted by PAFC commercialization will add to the demand balance exceeding secondary metal supply and will have to be answered by corresponding increases in the production of primary metal. Projections of PAFC platinum demand were developed in Section 3.3 for three market penetration levels and two platinum loading rate schedules. PAFC penetration of the on-site and electric utility generation markets was assumed to begin in 1985 and was projected through the year 2000. Figure 4-1 links the primary platinum demand projections of Section 2.3 with the PAFC platinum demand projections of Section 3.3 to illustrate the relative magnitude of PAFC platinum demand. Figure 4-1 includes platinum demand projections for both the United States and the world. Two separate PAFC demand projections are shown by Figure 4-1: (1) the probable demand projection derived from a middle range market penetration value using the probable fuel cell loading rate schedule, and (2) the high demand

ORIGINAL INTENT
OF POOR QUALITY

Figure 4-1. World and United States Primary Platinum Demand Forecasts, 1983-2000

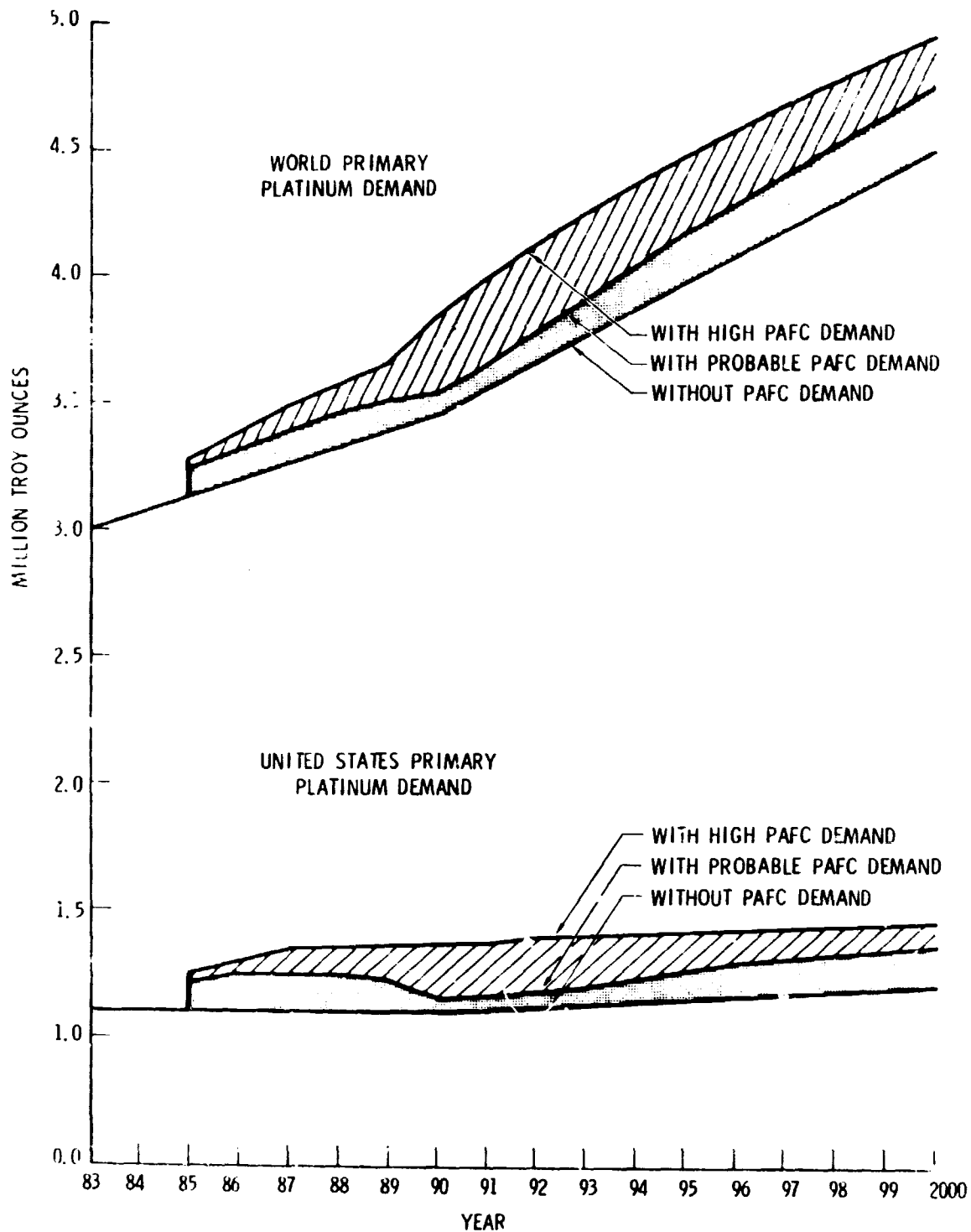

projections derived from a high range market penetration value using the worst case fuel cell loading rate schedule. These demand projections represent the net amount of platinum required and do not include platinum demand met by recycled platinum from other fuel cell power plants. The world platinum demand figures corresponding to Figure 4-1 are listed in Table 4-1.

An examination of Figure 4-1 reveals that PAFC commercialization will add small to moderate percentage increases to the yearly world and U.S. primary platinum demands during 1985-2000. The probable PAFC projection for the world will add 3.3 percent to world primary platinum demand starting in 1985. The size of the increase lessens to 2.2 percent in 1990 and then gradually grows to 5.2 percent in 1995 and 5.7 percent in 2000. The high PAFC demand projection will cause larger increases in platinum demand because of the higher market penetration level and the higher loading rate schedule. Worldwide, the high PAFC demand projection will cause a 4.4 percent increase in primary platinum demand in 1985. The yearly percentage increase will climb to 10.9 percent in 1990, peak at 12.7 percent in 1994, fall to 12.2 percent in 1995, and then decline to 10.0 percent in 2000.

The percentage increase in primary platinum demand caused by PAFC commercialization will be higher in the United States than in the world as a whole because the majority of PAFC market penetration during 1985-2000 is projected to occur in the United States. Figure 4-1 shows that the probable PAFC demand projection will cause a 9.3 percent increase in American demand in 1985. This demand increase will peak at 12.0 percent in 1987, fall to 3.1 percent in 1990, and then gradually climb to 11.5 percent in 2000. The high PAFC demand projection for the United States starts at 12.3 percent in 1985, rises to 23.5 percent in 1990, and then gradually falls to 19.1 percent by 2000.

The increase in U.S. platinum imports stimulated by PAFC commercialization has importance in terms of its effects on national reliance on foreign sources for strategic materials; however, in terms of impact on the world platinum market, the increase in world primary platinum demand is the more relevant factor. The BOM world platinum demand forecast projects demand for primary platinum to grow from 3.1 million troy ounces in 1984 to 4.5 million troy ounces in 2000. This is an average annual demand increase of 2.4 percent during this period. The probable PAFC platinum demand raises the average annual demand increase to 2.8 percent during this period. The high PAFC platinum demand raises it to 3.0 percent. Therefore, the increase in primary platinum demand caused by PAFC commercialization will probably raise the world demand growth rate for primary platinum by less than one-half percentage point. The worst projected increase will be only slightly more than one-half percentage point.

It should be noted that the BOM primary platinum demand forecast accounted for a small, unspecified amount of platinum demand by PAFC power plants. This analysis has ignored this small fraction because of its unspecified size and the fact that accounting for it, even if possible, would not affect the size of PAFC platinum demand and would lower total platinum demand by only a very small percentage.

Table 4-1. World Primary Platinum Demand Forecasts,
1984-2000 (1000 troy ounces)

<u>Year</u>	<u>BOM Forecast</u>	<u>Probable PAFC Demand</u>	<u>High PAFC Demand</u>
1984	3060	-	-
1985	3125	102	135
1986	3190	131	192
1987	3255	132	220
1988	3320	124	240
1989	3385	107	251
1990	3450	75	379
1991	3552	90	433
1992	3654	114	460
1993	3756	140	478
1994	3858	170	489
1995	3960	208	482
1996	4062	219	484
1997	4164	229	481
1998	4266	235	470
1999	4368	243	466
2000	4470	255	446

ORIGINAL FILED IN
OF POOR QUALITY

4.2 FUTURE PLATINUM SUPPLY

World reserves of platinum are estimated to be 520 million troy ounces. This is a sizable reserve since world demand is currently less than 3 million troy ounces per year. World reserves would last 192 years at the 1978 world production rate of 2.7 million troy ounces. The year 2000 production rate of 4.5 million troy ounces per year (as forecast by BOM) would require 116 years to exhaust world platinum reserves. BOM forecasts that 75.7 million troy ounces of platinum will probably be mined between 1978 and 2000. This is less than 7 percent of the current world reserve and would leave 444 million troy ounces of platinum reserves still unmined. In addition, resource exploration and improvements in mining technology will likely expand the size of world platinum reserves by upgrading portions of the platinum resource base to reserve status. In view of the size of world platinum reserves and the rates of current and projected platinum mining, it is evident that world platinum reserves are more than adequate to meet the world's demand for primary platinum metal for the remainder of this century and well into the next century, even with the added demand arising from PAFC commercialization.

Nearly 99 percent of the world's annual supply of primary platinum metal is mined in three countries: the Republic of South Africa (65%), the Soviet Union (29%), and Canada (5%). Predicted future increases in world platinum demand, including increases stimulated by PAFC commercialization, will require the expansion of platinum production facilities. During the past two decades, world platinum producers have demonstrated a remarkable ability to rapidly expand their production levels in response to escalating world demand. In the 11-year period from 1963 to 1974, annual world platinum production rose from 0.8 million troy ounces to 2.7 million troy ounces. This three and one-half fold increase was stimulated by rising Japanese jewelry demand in the 1960s and automobile catalytic converter demand in the 1970s. In the five years preceding introduction of catalytic converters on American automobiles (1969-1974), the annual world production of primary platinum jumped by nearly 1.5 million troy ounces.

The majority of recent platinum production increases was contributed by South African producers through a series of mine and refinery expansions. South African mines account for approximately two-thirds of the world's newly mined platinum and produce it as a main product rather than as a by-product. This permits control of platinum production levels. South African producers monitor indicators of future platinum demand and attempt to adjust their output accordingly. In 1970, these producers anticipated the forthcoming platinum demand of American automakers by rapidly increasing their production capabilities and inventories. The large platinum inventory that resulted caused production and prices to dip during the next two years until the inventory was diminished. The steep rise in production by the South Africans resumed in 1973 and 1974. Major mine expansions have occurred during the past several years and previously untapped reserves are now being evaluated for possible future production.

The platinum production of the Soviet Union and Canada together accounts for approximately one-third of the world's newly mined platinum. This production is a by-product of copper and nickel mining and hence its level is tied to world demands for copper and nickel. This dependence severely inhibits the ability of Soviet and Canadian producers to respond to fluctuations in world platinum demand. However, world demands for copper and nickel are forecast by BOM to grow at average annual rates of 3.6 percent and 3.9 percent, respectively, during 1978-2000. These rates are higher than the predicted annual growth rates for primary platinum metal. Over the long-term, therefore, by-product platinum production from copper and nickel mining should expand sufficiently to at least maintain a one-third share of the platinum market. This is assuming that the Soviet Union and Canada maintain their shares of the world copper and nickel markets.

In summary, the huge platinum reserves of South Africa combined with the proven ability of South African producers to rapidly expand their output within a short period of time indicate that South African producers should be able to increase production levels enough during the rest of the century to match increasing world demand for platinum including PAFC platinum demand. Soviet and Canadian platinum production will increase as a function of copper and nickel mining and will continue to supply a large percentage of world demand. However, the responsibility for meeting short-term jumps in demand will likely fall to South African producers because they have the ability to alter their production levels radically over the short term.

4.3 POTENTIAL PLATINUM PRICE CHANGES

The impact of PAFC commercialization on the price of platinum is analyzed by describing the cartel-like structure of the platinum supply market. PAFC platinum demand numbers are then applied to a simple economic model of this cartel structure to predict market behavior in terms of platinum price shifts. Insight of actual market behavior is provided by a case history of the platinum price effects stemming from the introduction of the use of platinum catalysts in automobile catalytic converters. A correlation analysis of several key factors is also conducted to provide additional insight into the importance of these factors in determining platinum price.

4.3.1 Market Structure*

A framework for analyzing the impact of increased demand for platinum, induced by PAFC penetration, on the world market price of platinum is provided by the economic theory of price determination. According to this theory, price is determined by the interaction of supply and demand. The supply of a product is modelled by a functional relationship which depicts the maximum quantity that would be produced as a function of the selling price. The demand for a product is modelled by a functional relationship which depicts the minimum quantity that would be purchased as a function of the selling price. Supply is an increasing function of price, and demand is

*Sections 4.3.1-3 were authored by Dr. Karl Wedemeyer and Jules Kamin of the Economic Evaluation Directorate, The Aerospace Corporation.

a decreasing function of price. Examples of demand and supply functions are labelled $D_x - D_x$ (demand) and $S_x - S_x$ (supply) in Figure 4-2. In a competitive market no individual producer or consumer can influence the market price. The equilibrium market price is determined as that price at which consumers would willingly purchase all of the product that producers would willingly sell. This condition occurs at the intersection of the supply and the demand functions. A price impact due to a shift of the demand function is just the difference between the post-shift and pre-shift equilibrium prices.

Certain aspects of the organization of the world platinum industry suggest that primary producers are operating as a cartel, however, and thus the competitive market model requires modifications for application to the platinum market. A cartel is an association of suppliers of a product that coordinates output in order to maximize profits. Production is coordinated because the maximum profits that may be obtained in this way exceed those which would be obtained without such cooperation.

A key to understanding production decisions by cartels, and the consequent impact of these decisions on the product price, is the economic theory of monopoly pricing. A monopoly occurs where a single supplier serves a market. Monopoly pricing is most easily understood when compared to competitive pricing. In a competitive industry both producers and consumers are price takers. That is, they base their respective production and consumption decisions on the market price which cannot be influenced by any one member of either group but which is determined by the collective interaction of their desires to supply and consume the product at any given price. The equilibrium market price occurs where the quantity that suppliers are willing to provide equals the quantity that consumers are willing to purchase. Competitive suppliers, when facing the equilibrium market price, expand production as long as the incremental or "marginal" revenue exceeds the marginal cost of the last unit produced. Since the incremental revenue from each unit produced and sold is the market price, the quantity supplied by each competitive producer is that for which marginal cost equals market price. A competitive market supply curve can be derived by summing, at each given price, the quantity that would be supplied by each producer. This is equivalent to summing all the producer's marginal cost curves.

In a monopoly market, the marginal revenue can be controlled by the single supplier. At successively lower prices, more of the product would be consumed as more buyers would be attracted into the market or as existing buyers bought more. The added revenue due to increased unit sales, however, is partly offset by the reduction in price needed to induce those sales. The monopolist expands supply as long as marginal revenue exceeds marginal cost, just as in the case of the competitive producer. Unlike the case of the competitive producer, however, marginal revenue is not equal to price. Price is determined by the point on the demand curve above the production rate at which marginal revenue equals marginal cost. The quantity supplied by the monopolist is lower and the price is higher than would occur with competitive supply conditions.

Figure 4-2. Functional Relationships of Supply and Demand Curves to Product Price and Level of Production

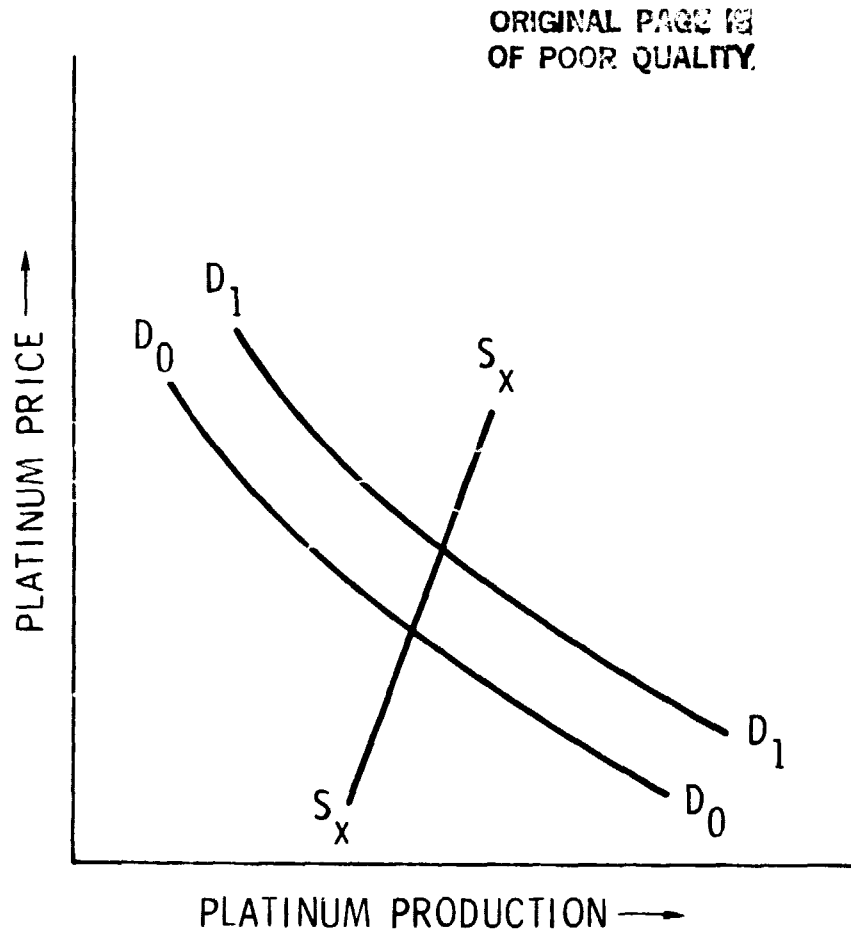

The monopoly market model has implications which, when compared to historical data on price and production, tend to support the conclusion that the primary platinum production industry operates as a cartel with members coordinating production to control price as if there were only one producer. The key to establishing a monopoly price and profits is control of the supply of the good. When there is more than one producer, maintaining coordination and monitoring of associates become increasingly difficult as the number of producers increases. If there are several phases of production, such as mining and refining, maintenance of control over end-use supply, which determines price, requires integration of operating decisions. As has been indicated elsewhere in this study, the primary platinum production industry is characterized by geographical, cultural and numerical concentration and by integrated ownership of production and refining facilities.

The observed behavior of producer price in real (i.e., inflation adjusted) dollars over a long period of time appears to be consistent with the model of market control. Figure 2-10 shows that producers successfully resisted dropping the price as far as dealers did on the occasions (1972, 1974, 1976, 1977, and 1981) when prices fell noticeably. In addition, producer price declines lagged the declines in the dealer price. These are indications of market control.

Another feature of the platinum market supports the cartel model. This is the low elasticity of the industrial demand for platinum. The elasticity of demand is the ratio of percentage reduction of quantity consumed to the percentage increase in price that causes the reduction. The lower the elasticity of demand, the higher the monopoly profit that can be obtained and, therefore, the greater the incentive to organize a cartel. The low elasticity of demand for platinum in industrial applications may be attributed to the lack of cheaper substitutes in its role as a catalyst in automobile pollution control and petrochemical processes.

The impact of introduction and penetration of PAFC's on the platinum market can be modelled in terms of a rightward shift of the demand curve in Figure 4-2. This curve, labelled D_0D_0 or D_1D_1 , shows the maximum price that would be paid by the marginal (i.e. "last") consumer for any given amount of total consumption. The rightward shift is depicted as a shift of the curve from the base position D_0D_0 to D_1D_1 . This indicates that the quantity demanded at any given price would be greater on D_1D_1 than on D_0D_0 by the amount of the horizontal shift between the two curves. The curve labelled S_xS_x is a postulated supply curve which shows the amount that would be produced at any given price in a competitive market. Market price is established at the intersection of the demand and supply curves. The shift of the demand curve from D_0D_0 to D_1D_1 results in a new curve intersection at a higher market price. This increase in demand may stimulate a shift of the entire supply curve to the right which would lower the market price.

If demand increases (i.e., shifts to the right) the monopolist's profit-maximizing price increase exceeds that which would occur in a competitive market of profit-maximizing price-taking producers. If demand decreases (i.e., shifts to the left) the monopolist's profit-maximizing price reduction is less than would occur in the competitive situation. The size of the price change when demand shifts and supply is stationary depends on the elasticity of supply in the competitive case but on both the elasticity of supply and the elasticity of demand in the monopoly case. Application of this methodology to obtain projected price increases due to PAFC demand shifts would require estimates of future elasticities of supply and demand as well as projections of prices and corresponding output rates. This is beyond the scope of this study. It is also possible to model the relationships algebraically and test sensitivities to alternative assumptions.

The actual response of platinum price and production rate to shifts in the demand curve may be less pronounced than those implied by the simple monopoly model. This is partly due to the role played by dealers who are numerous and behave competitively. The amount by which producers can raise the long-term contract price in response to an increase in demand may be limited to some extent by the additional supply that would be induced by the higher price. This supply would come from dealers' inventories and from additional reclamation of scrap. The extent of the effect would depend on the cost of dealer storage, the cost of reclamation, and expected future prices.

The fact that additional supplies would be forthcoming from a spot or short-term market does not negate the potential effect that these supplies would have on long-term prices. Since a futures market exists for platinum, a contract of maximum duration equal to the expiration date of the longest futures contract can be assembled, at some cost, from a spot contract and a sequence of futures contracts for spot deliveries in the future. The price implicit in this "homemade" contract cannot deviate too much from that of a long-term contract of the same maximum duration with a member of the producers' cartel.

Adjustment costs in the production-refining process may also play a role in dampening demand induced fluctuations in output and price. If the rate of monopoly profit is very high, cartel members may be relatively immune from price reductions resulting from short-run declines in demand. The costs of adjusting production rates, especially if adjustments must be made frequently, may offset the gains from maintaining continual short-run optimality of monopoly profit sufficiently for the cartel to avoid adjusting the production rate except when permanent long-run shifts in demand are perceived. The mere fact that a significant effort must be expended to coordinate production rates among cartel members must introduce considerable dampening into short-run adjustments. Thus, if demand falls off temporarily, the cartel is likely to maintain its production rate and store product in the expectation of a future rise in demand and a price above some "normal" level, when it would sell from stocks.

ORIGINAL PAGE IS
OF POOR QUALITY

4.3.2 Market Behavior

In the theoretical discussion which follows, it is assumed that the total world demand for platinum is fairly price inelastic. This would imply that changes in price which result from a general increase in demand will be higher on a percentage basis than the original percent change in overall demand which caused the price increases. Even though a case can be made for asserting that world platinum supply is price elastic, the available evidence relating to platinum producers would suggest that monopolistic conditions of supply prevail. As the following discussion explains, under these circumstances the price elasticity of the demand curve, in addition to that of the supply curve, determines the price response to a shift to the right (increase) in the demand curve.

The primary result of this situation is that the percentage price increase will always be higher than the percent increase in demand. How much higher cannot be determined without knowledge of the elasticities of both supply and demand, as explained below. At a minimum, however, a given annual percent increase in platinum consumption due to the introduction of a new set of platinum purchasers will at least raise the price, in the short run, by that percentage.

Table 3-3 of this report projects an initial platinum requirement based on a mid-range PAFC market penetration level occurring in 1985 of 102,820 troy ounces. Comparing this with a 1985 world demand quantity of 3,125,000 troy ounces, the increase in new demand for platinum, from 0 to 102,820, represents about a 3 percent demand shift in that year. Thus, successful market penetration of fuel cells as projected for 1985 would produce at least an increase in price of 3 percent. If the supply and demand elasticities are such that a 1 percent increase in demand leads to a 2 percent increase in price, which is not out of the question, then the price would go up by 6 percent for the 1985 case, which would definitely be a significant jump.

The high market penetration level is 1.33 times the figures shown in Table 3-3. This would produce a minimum price increase in 1985 of 4 percent, and an actual increase which could be much higher.

Based on the data presented in Table 3-3, projected PAFC demand for platinum increases from 1985 through 1987, and then decreases to a low of 75,330 troy ounces in 1990. PAFC platinum demand increases from 1991 through 2000, with the rate of increase peaking in 1994 and gradually declining thereafter. If all other demand factors remained unchanged (a highly unlikely possibility), it would be expected that world platinum prices would increase from the end of 1985 through 1987, decrease each year from 1988 through 1990, and then increase again from 1991 to the year 2000.

In reality, after the short-run impacts of the increased demand for platinum based on successful PAFC market penetration have been absorbed, moderate shifts in the demand for platinum derived from higher market penetration or

changes in usage during fuel cell manufacture will probably have very little effect on the price of platinum. The market for this rare metal is very complex. The fact that it is frequently produced jointly with other metals makes it somewhat difficult to develop independent supply or price estimates. Speculation in platinum tends to generate more erratic price fluctuations than would be the case for a more common mineral. General economic conditions, however, appear to affect platinum prices in a dramatic fashion; these impacts are likely to overshadow any future price impacts caused by increased PAFC market penetration.

4.3.3 Case History of Market Reaction

A certain amount of insight may be gained by studying the case of the introduction of catalytic converters in 1974. During this year, automotive demand for platinum amounted to 350,000 troy ounces, which represented an increase along the whole demand curve of about 12 or 13 percent (assuming production just equalled consumption during the year). Both dealer and producer prices, in fact, hit historic peaks early in the year, with dealer prices, the more volatile indicator, almost doubling from late 1973 levels. Nevertheless, by the end of 1974, both prices had declined significantly with dealer prices dropping all the way back down to 1973 levels. From the beginning of 1976 through the end of 1977, both price categories, while displaying a number of fluctuations, remained below \$200 per troy ounce. By mid-1980, both had more than doubled, climbing to levels above \$400 per troy ounce (up to almost \$1,000 with respect to dealer prices).

Meanwhile, during 1975, automotive use of platinum declined by 22 percent. After an increase in 1976, purchases of platinum dropped back to their original level in 1977. Then came a jump of 68 percent in 1978 followed by an increase of 34 percent in 1979 to a peak for the decade of 803,000 troy ounces. However, automotive demand declined by 36 percent in 1980. These figures suggest that it would not be easy to establish a significant, continuous relationship between changes in automotive demand for platinum and changes in the price of platinum.

Evidence would indicate that speculative pressure pushed platinum prices up early in 1974, although this may have been partially based on expectations of future purchases by the U.S. automotive industry. However, after this, the main factor affecting prices was the state of the U.S. economy, which went into a sharp recession during 1974-75. In 1977, with worldwide demand increasing, the supply of platinum was affected by both the Soviet Union and South Africa announcing plans to reduce production. Speculation caused sharp price fluctuations throughout the balance of the decade, but the main reason for constant upward movement in prices was the combination of increasing upward shifts in worldwide demand along with a relatively static supply curve.

In conclusion, after producing an initial short run impact, automotive demand for platinum remained a continuing, but minor, factor affecting changes in the price of platinum. With substantially lower percentages of

total world demand projected for PAFC platinum usage, even high market penetration is unlikely to cause severe long-run impacts on world platinum prices.

4.3.4 Correlation and Regression Analyses

Correlation and regression analyses are techniques for studying the relationship between two or more variables. Correlation analysis measures the closeness of the relationship between variables, while regression analysis derives an equation that relates a dependent variable to one or more independent variables. These techniques are used to measure the nature and degree of association between variables rather than to establish causality.

The dependent variable of interest is the producer price of platinum. The relationship of the following independent variables to the price of platinum was analyzed: (1) world primary platinum production, (2) the price of silver, (3) the consumer price index, (4) the U.S. gross national product, and (5) the exchange rate of the U.S. dollar to the United Kingdom (U.K.) pound. This group of independent variables was selected for analysis because it is indicative of price-determining forces: platinum demand, precious metal speculation, inflation, and the value of the dollar. Average annual data were collected for each variable for the period 1950-1980. These data are displayed in Table 4-2. Time is also included as an independent variable in terms of the last two digits of the data year.

A correlation analysis was performed to determine the strength of the linear relationship between the price of platinum and each of the independent variables. The relationships among independent variables was also calculated. The result of this analysis is given by the correlation matrix in Table 4-3. This matrix contains product-moment coefficients of correlation that may vary from -1 to +1. Perfect positive correlation, where an increase in one variable determines exactly an increase in the other variable, yields a coefficient of +1. Perfect negative correlation, where an increase in one variable determines exactly a decrease in the other variable, yields a coefficient of -1. As seen in Table 4-2, the producer price of platinum has the strongest correlation (0.9678) with the price of silver, and a relative weak correlation (0.7739) with the world primary production of platinum. It is interesting to note that the platinum price correlation with the time variable (0.7184) is nearly as strong as the correlation with platinum production. This is an indication of the weak correlation between platinum production and price.

A multiple regression analysis was conducted to derive a least-squares linear equation to fit the data of Table 4-2. This equation predicts values of the dependent variable (platinum price) based on the values of the independent variables. The multiple correlation coefficient, which correlates the actual values of platinum price with the predicted values of platinum price, was found to equal 0.9859. The square of this coefficient is called the coefficient of determination. It measures the percentage of

C-2

Table 4-2. Data Set for Correlation and Regression Analyses

<u>Year</u>	<u>Producer Platinum Price (\$)</u>	<u>World Primary Platinum Production (1000 Troy Ounce)</u>	<u>N.Y. Price of Silver (\$/tr.oz.)</u>	<u>Consumer Price Index</u>	<u>Gross National Product (\$ billion-current)</u>	<u>Foreign Exchange Rate (\$ per U.K. Pound)</u>
50	76.56	320	74.169	72.1	286.2	2.8007
51	90.00	350	89.368	77.8	330.2	2.7996
52	90.00	350	89.941	79.5	347.2	2.7926
53	91.24	400	85.188	80.1	366.1	2.8127
54	83.90	480	85.250	80.5	366.3	2.8087
55	85.98	490	89.099	80.2	399.3	2.7913
56	103.90	510	90.826	81.4	420.7	2.7957
57	89.45	620	90.820	84.3	442.8	2.7932
58	64.93	490	89.044	86.6	448.9	2.8098
59	73.25	510	91.202	87.3	486.5	2.8088
60	81.73	690	91.375	88.7	506.0	2.9076
61	82.00	710	92.449	89.6	523.3	2.8022
62	82.00	820	108.521	90.6	563.8	2.8078
63	79.76	790	127.912	91.7	594.7	2.8000
64	87.99	1040	129.300	92.9	635.7	2.7921
65	97.58	1210	129.300	94.5	688.1	2.7959
66	99.17	1230	129.300	97.2	753.0	2.7930
67	108.51	1280	154.967	100.0	796.3	2.7504
68	114.50	1370	214.464	104.2	868.5	2.3945
69	121.67	1403	179.067	109.8	935.5	2.3901
70	130.00	1839	177.082	116.3	982.4	2.3959
71	120.52	1708	154.564	121.3	1063.4	2.4442
72	120.78	1785	168.455	125.3	1171.1	2.5008
73	150.07	2365	255.756	133.1	1306.6	2.4510
74	180.85	2703	479.798	147.7	1412.9	2.3403
75	164.01	2613	441.852	161.2	1598.0	2.2216
76	161.73	2589	435.346	170.5	1756.1	1.8048
77	162.00	2705	462.302	181.5	1971.3	1.7449
78	237.25	2675	540.089	195.4	2235.2	1.9184
79	351.65	2856	1109.379	217.4	2539.0	2.1224
80	439.43	2900	2063.157	249.8	2756.0	2.3258

ORIGINAL PART IS
OF POOR QUALITY

Table 4-3. Correlation Matrix

	<u>Year</u>	<u>Platinum Price</u>	<u>Platinum Production</u>	<u>Silver Price</u>	<u>Consumer Price Index</u>	<u>Gross National Product</u>	<u>Foreign Exchange Rate</u>
Year	1.0000						
Platinum Price	0.7184	1.0000					
Platinum Production	0.9624	0.7739	1.0000				
Silver Price	0.6377	0.9678	0.6846	1.0000			
Consumer Price Index	0.8772	0.9294	0.9214	0.8781	1.0000		
Gross National Product	0.9056	0.9113	0.9409	0.8433	0.9955	1.0000	
Foreign Exchange Rate	-0.8293	-0.6201	-0.8824	-0.5193	-0.8338	-0.8547	1.0000

variation in the dependent variable that can be explained by the independent variables. It was calculated to be 0.9719. This means that more than 97 percent of the variation in platinum price can be explained by the variation in platinum production, silver price, gross national product, dollar exchange rate, and year. The consumer price index was dropped from the analysis because it did not improve the correlation. The standard error of the analysis is 14.6248.

In summary, the correlation analysis found that a weak correlation exists between platinum price and production. Stronger linear relationships exist between platinum price and silver price, the consumer price index, and the gross national product. The multiple regression analysis yielded a linear equation for platinum prices that correlated strongly with the actual values of platinum price. The analysis found that 97 percent of the variation in platinum prices is accounted for by the variation in the five independent variables.

4.4 PLATINUM PRICE EFFECT ON POWER PLANT COSTS

As previously discussed, platinum crystallines are used as catalysts on the anodes and cathodes of the fuel cell stack. As derived from Table 3-1, the average projected platinum loading rates of early commercial multimegawatt and multikilowatt PAFC power plants are 3.63 g/kW and 6.55 g/kW, respectively. At the current platinum producer price of \$475/tr. oz., these loading rates represent platinum costs of \$55/kW for multimegawatt power plants and \$100/kW for multikilowatt power plants.

PAFC manufacturers have established production cost goals for commercialization of PAFC power plants that range from \$700/kW to over \$1200/kW in 1981 dollars (Ref. 4-1). These are sale price goals based on a mature PAFC industry. In general, multimegawatt power plants are within the lower portion of this cost range while multikilowatt power plants compose the upper portion of the range. Assuming average initial capital costs of \$900/kW for multimegawatt power plants and \$1200/kW for multikilowatt power plants, the cost of platinum accounts for approximately 6.1 percent of the initial capital cost of multimegawatt power plants and approximately 8.3 percent of the initial capital cost of multikilowatt power plants.

PAFC power plants differ from many other energy conversion technologies in that they require the periodic replacement of a major subsystem -- the fuel cell stacks. During the assumed 20-year life of a PAFC power plant, three additional stacks would have to be purchased, assuming a stack replacement interval of five years. The initial capital cost figures do not account for these later capital expenses; therefore, fuel cell cost evaluation requires revised capital cost figures that account for stack replacement. Such capital cost figures are greater than the initial capital costs, but are less than the simple arithmetic sum of the initial capital costs plus the costs of all replacement stacks. The precise difference is dependent on the rate of inflation, replacement interval, and fixed charge rate assumptions. Since nearly all of the platinum catalyst (about 92 percent) will be

recovered from used stacks and reused in the replacement stacks, the purchase of new platinum will be a minor component of replacement stack cost. Consequently, the cost of platinum represents an even smaller percentage of the overall capital costs that account for later capital expenses than it does of the initial capital costs.

Section 4.3 predicts that according to assumed levels of PAFC market penetration and platinum loading, PAFC commercialization will likely cause an immediate jump of 3 to 6 percent in the price of platinum. Following this short-term impact, moderate shifts in platinum demand by PAFC market penetration will probably have little effect on the price of platinum.

The effect that a 3 to 6 percent increase in platinum price will have on the initial capital costs of PAFC power plants can be easily calculated. It was previously estimated that the cost of platinum at current producer prices is \$55/kW for multimegawatt power plants and \$100/kW for multikilowatt power plants. The 3 to 6 percent rise in platinum price will result in hikes of \$1.67 to \$3.33/kW in the initial capital costs of multimegawatt power plants and \$3.01 to \$6.01/kW in the initial capital costs of multikilowatt power plants. These cost increases represent only a fraction of a percent of the total initial capital costs of the power plants -- a high of 0.37 percent for multimegawatt power plants and a high of 0.50 percent for the multikilowatt power plants. The platinum cost increases will cause even smaller percentage increases in the overall capital costs of the power plants.

It is estimated that the high PAFC market penetration level will produce a 4 to 8 percent short-term increase in the price of platinum. An 8 percent increase in platinum price will cause only 0.49 and 0.67 percent increases in the initial capital costs of multimegawatt and multikilowatt power plants, respectively. In fact, the price of platinum would have to rise by 16.2 percent (based on a price of \$475/tr. oz.) to stimulate even a 1.0 percent increase in the initial capital costs of multimegawatt power plant. For multikilowatt power plants, the price would have to rise by 12.0 percent to cause a 1.0 percent increase in the initial capital cost. These platinum price increase figures would have to be even higher to produce a 1.0 percent increase in the overall capital costs of the power plants because of the credit received by recycling the platinum in used fuel cell stacks.

The platinum cost component of power plant costs could shrink if platinum loading rates decline as anticipated. Higher platinum prices would, therefore, have less of an impact on overall power plant costs. As PAFC technology develops, this effect may be offset, to some measure, by reductions in the costs of other power plant components.

4.5 VULNERABILITY OF U.S. PLATINUM SUPPLY

Although the United States now mines or refines more nonfuel minerals than any other country, it does not have the resource base to become self-sufficient in all the minerals and metals now being imported. The

vulnerable strategic materials of greatest concern to the United States are chromium, cobalt, manganese, tantalum, and the platinum-group metals, because a substantial portion of these metals is produced in potentially unstable or unfriendly countries. As detailed in Section 2, nearly 95 percent of the world supply of platinum originates in the Republic of South Africa and the Soviet Union.

The chance that U.S. imports of platinum may be interrupted, at least temporarily, at some future date is increased by three factors: (1) the cartel-like relationship of the several large South African producers, (2) the possibility of political instability in the Republic of South Africa, and (3) the possible use of platinum exports as a political weapon by the Soviets. The United States relies on three South African mining companies for over three-quarters of its supply of primary platinum. These producers standardize their platinum prices and control the long-term worldwide supply and price of platinum by manipulating their production and inventories. They do not have a history of causing major supply disruptions and, in fact, have aggressively attempted to meet all increases in demand. However, the control of the market by such a small number of private foreign producers is cause for some degree of concern regarding the future possibilities of supply restrictions.

Subequatorial Africa has important deposits of important minerals and metals that have attracted the attention of both the West and the Soviet Union. Political developments in the mineral-producing countries in central Africa coupled with recent shifts in the Soviet Union's policy on procuring minerals have increased the likelihood of supply disruptions of many African mineral and metal exports (Ref. 4-2). Sources of African platinum are limited almost entirely to the Republic of South Africa, however, and this is one of the few South African countries that has not had its mineral production affected by political unrest or Soviet influence. Despite this, the racial policies of the government of the Republic of South Africa have caused it to be ostracized by much of the world community and has created a large potential for social and political upheaval within the country. Major internal strife within the Republic of South Africa, possible although not necessarily inevitable, could disrupt platinum exports for a significant period of time.

The Soviet Union produces approximately 28 percent of the world's platinum but accounts for only a small percentage of United States supply. The Soviets have halted deliveries of platinum to the United States in the past as a political gesture. Deliveries were stopped in late 1979, for example, because of the Afghanistan situation. The Soviet component of U.S. supply is not large enough for its absence to cause an important supply problem; however, since most Soviet platinum is marketed through the dealer market, withdrawal of Soviet supply does cause increases in the dealer price of platinum.

In summary, the greatest threat to the U.S. platinum supplies appears to be the potential for social and political upheaval in the Republic of South

Africa. In the event of major internal disorder, platinum exports to the United States could be suspended. A lengthy suspension would be a blow to U.S. industry because of its heavy reliance on South African platinum. It does not appear likely that the South African government or producers would voluntarily cease platinum exports to the United States, and suspension of Soviet-supplied platinum would not have enough impact to significantly disrupt U.S. platinum users.

The best means of alleviating short- and mid-term disruptions in imported supplies of platinum is usage of government and private platinum inventories. As described in Section 2.2.7, the goal of the National Defense Stockpile with regard to platinum is the supply of military and essential civilian platinum requirements for three years. This stockpile currently contains enough platinum to meet these requirements for only about one year and most of this platinum is in forms unusable for most applications. The federal government is taking steps to upgrade and expand this platinum stockpile. Private inventories of platinum fluctuate in size according to market conditions but tend to average around one-half million troy ounces. These inventories would be pressed into use in the event of a supply disruption and would be large enough to meet all U.S. demands for a four-month period if properly distributed. In the event that a platinum priority use system is ordered by the federal government, PAFC platinum use would probably be ranked above some uses (e.g., jewelry and catalytic converters) and ranked below other uses (e.g., petroleum and chemical).

Long-term platinum supply disruptions would exhaust stockpiles and inventories and would have to be mitigated by other actions. Market forces would likely foster development of domestic platinum resources, improved platinum recovery techniques, additional platinum recycling, and substitution of other materials for platinum where feasible. These actions would lessen reliance on imports, but only over the long term. They would also raise the price of platinum (Ref. 4-2).

For example, development of the Stillwater platinum deposit in Montana would take several years and could supply about one-quarter of domestic demand. Development of sizable platinum mines in Montana, Minnesota, and Alaska would not supply enough platinum, however, to replace the loss of South Africa imports (Ref. 4-3).

PAFC power plants use rather than consume their platinum catalysts and most of the catalyst is recoverable for reuse. It is estimated that approximately 92 percent of the platinum in the fuel cell stack will be recycled and this figure could go higher with improvements in recovery technology. A disruption in platinum supply will, therefore, have a diminished effect on PAFC power plants already in the field since they will require only a periodic topping off of their catalyst. Production of new PAFC power plants will be more severely affected by a supply disruption, however, since new units require a full initial platinum loading.

ORIGINAL PAGE IS
OF POOR QUALITY

A platinum supply disruption will destabilize the price of platinum and will likely result in a large increase in price until supply is resumed. If platinum is available for purchase through the market or from private inventories, its high price will increase the cost of replacement fuel cell stacks and new PAFC power plants. For example, a doubling of platinum price, from \$475/tr. oz. to \$950/tr. oz., would increase the cost of replacement stacks by 1.5 percent in multimegawatt power plants and 2.0 percent in multikilowatt power plants (assuming that cost of replacement stacks equals one-third of the initial capital cost of the power plant). The same doubling of price would cause the initial capital cost to rise by 6.2 percent for multimegawatt power plants and 8.3 percent for multikilowatt power plants.

4.6 DISCUSSION OF STUDY FINDINGS

This section has merged platinum market data and PAFC platinum use data from the previous two sections to analyze the effects of PAFC platinum demand on the supply and pricing facets of the world platinum market. The following is a discussion of the findings generated by this study regarding platinum demand, supply, and pricing; PAFC power plant costs; and platinum supply vulnerability.

Platinum Demand - The annual U.S. demand for platinum doubled during the 1970s, primarily because of the use of platinum in automobile catalytic converters. The United States currently imports about one-half of the world's production of primary platinum. Recent platinum demand forecasts agree that U.S. and worldwide platinum demand will continue to grow for the remainder of the century. The U.S. demand for primary platinum is expected to grow at an average annual rate of approximately 1.5 percent through the year 2000, while worldwide demand increases at an average annual rate of approximately 3 percent. The higher worldwide growth rate will reduce the U.S. share of world primary platinum imports to slightly more than one-quarter by the year 2000.

The Bureau of Mines forecasts that the U.S. will demand a cumulative total of 24.3 million troy ounces of primary platinum during 1978-2000. Cumulative world demand for primary platinum is forecast to be 75.7 million troy ounces during this period. These forecasts are based on analyses of future platinum usage trends. Unexpected new platinum applications or alterations of existing applications could radically change these forecast totals.

The platinum demand of PAFC power plant commercialization to the year 2000 was estimated by assuming platinum loading rate schedules and power plant market penetration levels. These assumptions were based on previously published studies, expert opinion, and the general consensus of the fuel cell development community. It was determined that the commercialization of PAFC power plants will probably require cumulative platinum totals of 1.63 million troy ounces in the United States (range of 1.08 to 3.86 million troy ounces) and 2.58 million troy ounces worldwide (range of 1.72 to 6.14

million troy ounces). The probable PAFIC demand totals will increase the BOM cumulative demand forecasts for the U.S. by 6.7 percent and for the world by 3.4 percent. The high range demand numbers will increase the BOM forecasts by greater percentages: 15.9 percent for the United States and 8.1 percent for the world.

It is estimated that development of PAFIC power plants in the United States is about five years ahead of development in Japan and Europe. This lead should give U.S. developers a good opportunity to capture most or all of the domestic PAFIC power plant market to the year 2000, and possibly a percentage of the foreign market. Production of PAFIC power plants in the United States for export would further increase U.S. platinum imports. It should be remembered, however, that the increase in overall world primary platinum demand is the important factor in terms of impact on the world platinum market. Platinum producers will have to supply the platinum demands of PAFIC power plant commercialization regardless of whether the power plants are manufactured in the United States, Japan, or Europe.

PAFIC power plant commercialization will add small percentage increases to the yearly world demand for primary platinum during 1985-2000. The probable PAFIC platinum demand projection for the world will add 3.3 percent to world primary platinum demand starting in 1985 (assuming commercialization begins in 1985). The size of the increase lessens to 2.2 percent in 1990 and then gradually grows to 5.2 percent in 1995 and 5.7 percent in 2000. The high PAFIC platinum demand projection will cause larger increases in platinum demand because of the higher market penetration level and the higher loading rate schedule. Worldwide, the high PAFIC platinum demand projection will cause a 4.4 percent increase in primary platinum demand in 1985. The yearly percentage increase will climb to 10.9 percent in 1990, peak at 12.7 percent in 1994, fall to 12.2 percent in 1995, and then decline to 10.0 percent in 2000.

Platinum Supply - World reserves of platinum are large enough to last for more than 192 years at 1978 production levels and more than 116 years at projected year 2000 production levels. The size of these reserves could increase in the future as the methods of locating and extracting the resource are improved. Current reserves are more than sufficient to meet worldwide demands for primary platinum, including PAFIC platinum demand, for the remainder of this century and well into the next century.

Although the United States has an estimated 60 million troy ounces of platinum resources, only about 1.0 million troy ounces of this resource are classified as reserves (e.g., economical to extract). The United States produces several thousand troy ounces of platinum per year, primarily as a by-product of copper mining, and this production satisfies only a tiny fraction of one percent of total domestic demand. Nearly all the platinum used in the United States is imported and the overwhelming majority of these imports comes directly or indirectly from the Republic of South Africa. At least one large platinum resource area in the United States is being seriously studied for possible development (Stillwater Complex in Montana),

but the chances of actual development are hampered by marginal economic conditions and environmental constraints. Development of this large resource would take several years and it would only supply about one-quarter of domestic demand. In fact, it is estimated that the development of all domestic platinum resources would not result in enough new platinum production to replace the need for at least some imported platinum. Therefore, in lieu of significant reductions in domestic platinum demand, the United States will continue to be dependent, at least in part, on imported platinum.

World platinum reserves are almost entirely limited to South Africa (88 percent) and the Soviet Union (11 percent), with a small amount of reserves in Canada. Only South Africa currently mines platinum as a primary product; the platinum production rates of other producing countries are closely tied to their copper and nickel production rates. The rate of annual world platinum production doubled during the 1970s to nearly 3 million troy ounces in 1980. Production output is divided between South Africa (65 percent), the Soviet Union (29 percent), and Canada (5 percent). Nearly all of South Africa's huge platinum production is mined by just three companies. These effectively control about two-thirds of the world's primary platinum production. They operate in a cartel-like arrangement by coordinating their production and pricing levels.

Platinum producers, primarily the South Africans, have demonstrated an ability over the past two decades for rapidly expanding their platinum output in response to major jumps in world platinum demand. Large platinum demand increases were satisfied in the 1960s (Japanese jewelry) and the 1970s (American catalytic converters). Recent mine and refinery expansions indicate a continuation of this response capability. It is generally assumed that the platinum producing countries will be capable of expanding their production facilities to match any reasonable forecasts of world platinum consumption. This expansion could be inhibited by two important factors, however: (1) approximately one-third of the current world production of platinum is a by-product of copper and nickel mining in Canada and the Soviet Union, and thus the growth of production from these sources will be a function of the growth of copper and nickel production in these two countries, and (2) since platinum is usually found in association with the other five PGMs, increased platinum production could oversupply and imbalance the markets of these other PGMs. Overall, only South Africa has the resources and production flexibility to rapidly increase platinum production in response to sudden jumps in world demand. The responsibility for meeting demand increases induced by PAFC commercialization will likely rest on the three big South African producers.

Consumption of platinum by most industries is largely nondissipative which often permits recovery and reuse of the platinum. The annual amount of platinum recycled in the United States (toll and nontoll) averaged approximately 0.7 million troy ounces during 1975-1980. This secondary platinum accounted for between one-third and one-half of the total amount of platinum used in the United States. The use of secondary platinum by U.S.

ORIGINAL PAGE IS
OF POOR QUALITY

industries is projected by the Bureau of Mines to increase substantially during the rest of the century. It is estimated, for example, that recycling of automobile catalytic converters could supply 300,000 troy ounces of platinum per year. Recycling will retard the growth of primary platinum demand, but the use of secondary platinum will probably not increase quickly enough to actually decrease the level of primary platinum demand.

Platinum Price - The South African platinum producers coordinate their production levels and prices and, therefore, appear to be operating in a cartel-like manner. Since these producers market approximately two-thirds of the world's primary platinum, their production and pricing policies greatly affect the world market price of platinum. In fact, the two largest South African producers jointly set the producer price and their production levels have a major influence on the dealer price.

In general, the producer price applies to industrial accounts and to long-term purchases while the dealer price pertains to spot purchases. The dealer price responds to actual market demand and is much more dynamic than the producer price. The producer price often remains at the same level over long periods of time before being reset by the producers. The dealer price usually stays close to the producer price, but in times of surging or shrinking platinum demand, the dealer price will often split away from the producer price by significant margins. The producers will often adjust their prices upward and downward to match dealer prices; but rather than always dropping their prices to match falling dealer prices, they sometimes reduce production to eliminate market surpluses and force the dealer price back up.

The South African producers have a history of promptly increasing their output in response to higher platinum demand. Despite this history of benevolent behavior towards the world's platinum consumers, the price impact of PAFC power plant commercialization on the world price of platinum should be analyzed with a monopoly model of market price determination rather than a competitive model. It is estimated by this study that the long-term platinum price increase triggered by PAFC commercialization will not be severe unless PAFC platinum demand is much higher than expected. Moderate market penetration with probable platinum use rates will likely produce a 3 to 6 percent increase in platinum price in the first year of widespread commercialization (1985) over the price that would be demanded in the absence of PAFC penetration. This increase could rise to a 4 to 8 percent range with high market penetration and high platinum use rates. After short-run price impacts, moderate shifts in platinum demand by PAFC commercialization will probably have little effect on the price of platinum, since general economic conditions are likely to overshadow any further price impacts of PAFC commercialization.

Correlation and regression analyses found a weak correlation between the producer price of platinum and the world production of primary platinum. The price of platinum appears to correlate much more strongly with precious

metal speculation (as reflected by the price of silver) and with general economic conditions (as reflected by the consumer price index and the gross national product). This finding supports the proposition that moderate shifts in platinum demand should have little effect on the price of platinum after the initial short-run impacts.

Power Plant Cost - If one assumes average initial capital costs of \$900/kW and \$1200/kW in 1981 dollars for multimegawatt and multikilowatt PAFC power plants, respectively, the cost of platinum accounts for approximately 6.1 percent of the initial capital cost of multimegawatt power plants and approximately 8.3 percent of the initial capital cost of multikilowatt power plants. These average initial capital cost figures are cost production goals established by PAFC power plant manufacturers for a mature PAFC industry. The cost of platinum is based on projected platinum loading rate schedules and the current platinum producer price of \$475/tr. oz.

A 3 to 6 percent rise in platinum price will result in initial capital cost hikes of \$1.67 to \$3.33/kW for multimegawatt power plants and \$3.01 to \$6.01/kW for multikilowatt power plants. These cost increases represent only a fraction of a percent of the total initial capital costs of the power plants--a high of 0.37 percent for multimegawatt power plants and a high of 0.50 percent for the multikilowatt power plants. Based on a price of \$475/tr. oz., the price of platinum would have to rise by 16.2 and 12.0 percent to cause a 1.0 percent increase in the initial capital costs of multimegawatt and multikilowatt power plants, respectively. These figures indicate that the initial capital cost of PAFC power plants is fairly insensitive to changes in platinum price.

The initial capital cost figures of PAFC power plants do not account for the periodic replacement of the fuel cell stacks during the life of the power plant. Capital cost figures that do account for these later capital expenses are greater than the initial capital costs. However, since nearly all of the platinum (92 percent) will be recovered from the used stacks and reused in the replacement stacks, the purchase of new platinum for the replacement stacks will be a small part of the replacement cost. In fact, the cost of platinum is a smaller percentage of the replacements than it is of the initial capital costs. This means that platinum cost is a smaller part of the overall capital costs than it is of the initial capital costs and that the price of platinum would have to rise even higher than the 16.2 and 12.0 percent levels to cause a one percent increase in the overall capital costs that account for later capital expenses.

Supply Vulnerability - Nearly 95 percent of the world supply of primary platinum originates in the Republic of South Africa and the Soviet Union. The United States is almost entirely dependent on imported platinum to meet its platinum demands; in fact, the United States receives about three-quarters of its primary platinum directly from three South African mining companies and much of the remainder indirectly from these same three companies. This platinum supply situation has elevated platinum to nearly the top of the U.S. list of strategically important materials and has put the United States in a position of serious supply vulnerability.

ORIGINAL PAGE IS
OF POOR QUALITY

Disruption of U.S. platinum imports could be caused by (1) conflict in or around South Africa, (2) cartel action by the South African producers, or (3) use of platinum exports as a political weapon by the Soviets. Of these possible causes, the most threatening appears to be the potential for conflict in or around South Africa. The government's racial policies have created the potential for social and political upheaval within the country that could halt platinum production for an extended period. Also, regional or global conflict could sever supply routes and thus isolate the South African producers from world consumers. It's beyond the scope of this study to evaluate the likelihood of internal or external conflict related to South Africa, but the occurrence of such conflict is not inevitable.

Cartel action by South African producers against the United States in order to radically raise platinum prices is very unlikely. The government of South Africa relies on the friendship of the U.S. government for support within an international community opposed to the South African racial policies. It's doubtful that the South Africans would risk this support for the monetary gains of higher platinum prices. An intentional cutback in Soviet platinum exports is also unlikely. The Soviets depend on the sale of platinum and other metals as an aid to their national economy and a prolonged stoppage of these exports could worsen domestic economic problems. The Soviets have halted deliveries of platinum to the United States in the past as a political gesture, but the Soviet component of U.S. supply is not large enough for its absence to cause a serious supply problem.

In the event of a major disruption in its platinum imports, the United States would be forced to rely on its platinum stockpiles and inventories for short- and mid-term relief. Private industry and the federal government each holds the equivalent of about a four-month domestic supply of platinum in reserve. The industry reserves are readily available for use on demand, but government stockpiles are held for emergency use only and most of them are not in usable forms for industry. Until these stockpiles are upgraded, they cannot be counted as a hedge against a supply disruption.

Long-term supply disruption would exhaust inventories and stockpiles and would necessitate means of reducing reliance on imported platinum. Actions would probably be taken to recycle greater quantities of platinum, substitute suitable materials for platinum, and possibly develop domestic reserves of platinum. A combination of these actions could eventually compensate for the loss of platinum imports.

A platinum supply disruption will probably result in a large increase in platinum prices until supply is resumed. This will increase the cost of new PAFC power plants and replacement fuel cell stacks. A doubling of the platinum price of \$475/tr. oz. would increase the cost of replacement stacks by 2.0 percent or less, and increase the initial capital cost of new PAFC power plants by 6.2 and 8.3 percent. The projected price increase for replacement stacks is low because of the credit received for recycled platinum.

4.7 REFERENCES

- 4-1. National Aeronautics and Space Administration, Lewis Research Center, Phosphoric Acid Fuel Cell Program Lead Center Operating Plan, For the period January 1, 1982 to December 31, 1982, January 1982.
- 4-2. Lawrence Livermore National Laboratory, "How Vulnerable Are U.S. Sources of Strategic Materials?," Energy Technology Review, February 1982.
- 4-3. U.S. Bureau of Mines, Mineral Facts and Problems, Bulletin 671, 1980 edition.

ORIGINAL PAGE IS
OF POOR QUALITY

5. SUMMARY AND CONCLUSIONS

PAFC power plants use platinum catalysts in the anodes and cathodes of their fuel cell stacks. This study was conducted to evaluate the impacts that the platinum demand of PAFC power plant commercialization will have on the worldwide supply and price of platinum during 1985-2000. In specific, this study evaluates the effects of PAFC platinum demand on (1) the ability of platinum producers to meet world platinum demand, (2) the market price of platinum, and (3) the capital costs of PAFC power plants. These are issues of concern for PAFC development because inadequate platinum supplies and inflated prices could raise the capital costs of PAFC power plants and thereby hamper commercialization.

The background information necessary for this study is provided in Sections 2 and 3. Section 2 consists of a comprehensive description of the world platinum market, including world platinum demand forecasts. Section 3 describes projections of PAFC market penetration and PAFC platinum use rates, as well as the assumptions inherent in these projections. Section 4 analyzes the background information to develop conclusions regarding platinum supply and price and their effects on PAFC power plant costs. This section summarizes the information generated in Sections 2 through 4 and reviews the conclusions developed by this study.

5.1 PLATINUM MARKET

World reserves of platinum are highly localized in a few countries, and these countries are responsible for nearly all of the world's production of primary (newly mined) platinum. For example, the Republic of South Africa has 88 percent of the world's platinum reserves and produced 65 percent of the 1978 world primary platinum output of 2,675,000 troy ounces. The Soviet Union produced 29 percent of this world output, and Canada contributed 5 percent. Only the Republic of South Africa currently mines platinum as a primary product; the platinum production of other producing countries is a by-product of copper and nickel mining and, therefore, is closely tied to the production rates of these metals. The world production of platinum has risen substantially during the past decade, and platinum producers are continuing to expand their production facilities.

Although the U.S. has large platinum resources, only a tiny fraction of these resources is classified as platinum reserves. Domestic platinum production is almost insignificant (about 1,000 troy ounces in 1978), and practically all domestic demand must be met by imported platinum. The United States is a major platinum consumer and imported 47 percent of the world's production of primary platinum in 1978. U.S. platinum imports increased greatly during the 1970s, while U.S. platinum exports remained steady.

ORIGINAL PAGE IS
OF POOR QUALITY

Seventy percent of all platinum used in the U.S. is for catalytic purposes. The automobile industry consumes nearly half of the total U.S. demand. Other major users include the electronics, petroleum refining, and chemical industries. Much of the platinum used in the petroleum, chemical, and glass industries is recovered and reused. The platinum in automobile catalytic converters is not currently recycled on a large scale.

Because of platinum's many important uses and the near nonexistence of a domestic primary platinum supply, platinum has been placed near the top of the nation's list of strategic materials. Private industry and the federal government each holds the equivalent of about a four-month domestic supply of platinum in reserve. The industry reserves are readily available for use on demand, but government stockpiles are held for emergency use only and most of them are not in usable forms for industry.

Recent forecasts agree that platinum demand by the United States, and by the world as a whole, will continue to grow for the remainder of the century. This growth rate will be highest during the 1980s and will gradually shrink during the 1990s. The annual world demand for primary platinum is expected to grow from 2,675,000 troy ounces in 1978 to 4,470,000 troy ounces in 2000. The United States is forecasted to demand 24.3 million troy ounces of primary platinum during 1978-2000; the world is forecasted to demand 75.7 million troy ounces of primary platinum during this period. The domestic chemical and jewelry industries are expected to expand their demand for platinum during the next 20 years, while the domestic automobile and petroleum refining industries are expected to reduce their demand over the same period.

There are basically three prices for platinum: the producer price, the dealer price, and the futures price. The producer price is set by several large South African producers, the dealer price is determined by several large bullion dealers in the United States and overseas, and the futures price is established on the New York Mercantile Exchange. Short-term price trends are generally set by the dealers and futures market and followed by the producers. The South African producers effectively control long-term price trends, however. After remaining steady for more than two decades, the producer price of platinum began a steep increase in 1977 that lasted until 1980 when it leveled out at \$475/tr. oz. It has remained at this level while the dealer price has fluctuated around it.

5.2 PAFC COMMERCIALIZATION

PAFC power plants utilize the catalytic properties of platinum to facilitate electrochemical reactions in the anodes and cathodes of the fuel cell stacks. All prototype PAFC power plants currently under development use platinum as the fuel cell catalyst. The two important factors in determining the future platinum demand of PAFC power plant commercialization are: (1) the PAFC platinum use rates per unit of installed capacity, and (2) the market penetration of PAFC commercialization in terms of newly installed capacity per year.

ORIGINAL PAGE IS
OF POOR QUALITY

The average platinum loadings (in terms of power output) projected for the early commercial multimegawatt and multikilowatt PAFC power plants are 3.60 mg/W and 6.60 mg/W, respectively. Fuel cell research activities are attempting to lower these platinum loading rates by increasing the efficiency of platinum use and substitute other suitable catalysts for platinum. Research trends indicate that the platinum loadings of mature commercial PAFC power plants will be less than those projected for early commercial PAFC power plants. This study assumes that future platinum loading rates will be reduced according to either of two schedules. The first schedule is considered by NASA-Lewis Research Center fuel cell researchers to be the most likely estimate of the future platinum loading trend. It reduces the loading rate projected for early commercial PAFC power plants by 60 percent from 1985 to 1990, and then holds the loading rate steady to 2000. The second schedule is considered the worst possible case and reduces the loading by only 33 percent over the entire 1985-2000 time period.

Following the assumption that 90 percent of installed PAFC capacity will be in the form of large electric utility power plants and only 10 percent will be in the form of the smaller on-site power plants, the projected early commercial loading rate figures of 3.60 mg/W (average of electric utility power plants) and 6.60 mg/W (average of on-site power plants) can be combined to give a composite of 3.90 mg/W. Reducing the composite loading figure of 3.90 mg/W by 60 percent yields a composite figure of 1.55 mg/W for use by the "probable case" schedule in 1990. The conservative or "worst case" schedule reduces the 3.90 mg/W composite by 33 percent to yield a 2.60 mg/W composite for its use in the year 2000.

A range of market penetration figures for both the United States and global electric generation markets are formulated by this study. The penetration forecast for the U.S. market is 20,000 to 40,000 MW by 2000. The forecast range is wide because of the numerous uncertainties currently surrounding PAFC commercialization. Little information is available on market penetration potential of foreign markets. It was assumed that the combined penetration of foreign markets by PAFC power plants will be equivalent to domestic penetration levels but that their onset and magnitude will lag five years behind U.S. penetration. It was further assumed that U.S. market penetration levels will be reached during a 16-year period commencing in 1985 and extending through 2000. The growth of the combined European and Japanese market penetration was assumed to be identical to U.S. penetration except that it will commence in 1990 rather than in 1985 and it will lag the level of U.S. penetration by five years.

The operational life of preprototype fuel cell stacks is approximately 40,000 hours or about five years with near continuous operation. Improvements in stack duration are likely, but the conservative figure of five years is adopted for this study. At the end of five years of operation, the fuel stack will require removal and reconditioning. Much of the platinum catalyst will be recovered and reused during reconditioning. Using the 92 percent recovery figures discussed in Section 3.1, about 8

percent of the platinum in PAFC power plants will require replacement every five years. The need to supplement fuel cell catalysts will begin five years following the initiation of commercialization. According to our projected penetration schedule, platinum supplements will be required in the U.S. market beginning in 1990 and in the foreign markets beginning in 1995.

According to the probable case loading schedule, PAFC commercialization during 1985-2000 will demand a cumulative amount of platinum in the United States equal to 1,626,620 troy ounces. This demand could range as high as 2,168,000 troy ounces or as low as 1,084,000 troy ounces. Cumulative PAFC demand for the entire world, including the United States, is projected to be 2,561,680 troy ounces during 1985-2000 with a range of from 1,721,000 to 3,442,000 troy ounces. The platinum demands induced by the worst case loading schedule are significantly higher than the demands induced by the probable case loading schedule. Cumulative worst case demand for the United States through 2000 is projected to be 2,898,750 troy ounces with a range from a low of 1,932,000 troy ounces to a high of 3,864,000 troy ounces. For the entire world, the cumulative demand is projected to be 4,606,380 with a range of from 3,071,000 to 6,142,000 troy ounces.

5.3 MARKET ANALYSIS

The PAFC platinum use data are merged with the platinum market data in order to analyze the effects of PAFC commercialization on the supply and price of platinum, and the resulting impact on the capital costs of PAFC power plants. This study finds that PAFC commercialization will add small percentage increases to the yearly world demand for primary platinum during 1985-2000. The probable PAFC platinum demand projection for the world will add 3.3 percent to world primary platinum demand starting in 1985 (assuming commercialization begins in 1985). The size of the increase lessens to 2.2 percent in 1990 and then gradually grows to 5.2 percent in 1995 and 5.7 percent in 2000. The high PAFC platinum demand projection will cause larger increases in platinum demand because of the higher market penetration level and the higher loading rate schedule. Worldwide, the high PAFC platinum demand projection will cause a 4.4 percent increase in primary platinum demand in 1985. The yearly percentage increase will climb to 10.9 percent in 1990, peak at 12.7 percent in 1994, fall to 12.2 percent in 1995, and then decline to 10.0 percent in 2000.

The producers responsible for a majority of the world's primary platinum production appear to be operating as a cartel, and therefore the price impact of PAFC market penetration should be analyzed with a monopoly model of market price determination rather than a competitive model. It is estimated by this study that the long-term platinum price increase triggered by PAFC commercialization will not be severe unless PAFC platinum demand is much higher than expected. Moderate market penetration with probable platinum use rates will likely produce a 3 to 6 percent increase in platinum price in the first year of widespread commercialization (1985) over the amount that would be demanded in the absence of PAFC penetration. This increase could rise to a 4 to 8 percent range with high market penetration

and high platinum use rates. After short run price impacts, moderate shifts in platinum demand by PAFC commercialization will probably have little effect on the price of platinum since general economic conditions are likely to overshadow any further price impacts of PAFC commercialization.

Assuming average initial capital costs of \$900/kW and \$1200/kW for multimegawatt and multikilowatt PAFC power plants, respectively, the cost of platinum accounts for approximately 6.1 percent of the initial capital cost of multimegawatt power plants and approximately 8.3 percent of the initial capital cost of multikilowatt power plants. A 3 to 6 percent rise in platinum price will result in initial capital cost hikes of \$1.67 to \$3.33/kW for multimegawatt power plants and \$3.01 to \$6.01/kW for multikilowatt power plants. These cost increases represent only a fraction of a percent of the total initial capital costs of the power plants--a high of 0.37 percent for multimegawatt power plants and a high of 0.50 percent for the multikilowatt power plants. Based on a price of \$475/tr. oz., the price of platinum would have to rise by 16.2 and 12.0 percent to cause a 1.0 percent increase in the initial capital costs of multimegawatt and multikilowatt power plants, respectively. The price of platinum would have to rise even higher to cause a 1.0 percent increase in the overall capital costs of the power plants.

World reserves of platinum are large enough to last for more than 192 years at 1978 production levels and more than 116 years at projected year 2000 production levels. These reserves are more than sufficient to meet worldwide demands for primary platinum, including PAFC platinum demand, for the remainder of this century and well into the next century. Platinum producers, primarily the South Africans, have demonstrated an ability over the past two decades for rapidly expanding their platinum output in response to major jumps in world platinum demand. Large platinum demand increases were satisfied in the 1960s (Japanese jewelry) and the 1970s (American catalytic converters). Recent mine and refinery expansions indicate a continuation of this response capability.

Nearly 95 percent of the world supply of primary platinum originates in the Republic of South Africa and the Soviet Union, and the United States relies on three South African mining companies for over three-quarters of its supply of primary platinum. In the event that internal or external conflict disrupts the South African supply of platinum to the United States, the United States would be forced to rely on its platinum stockpiles and inventories for short- and mid-term relief. Long-term supply disruptions would exhaust these stockpiles and inventories and would necessitate means of reducing reliance on imported platinum. A platinum supply disruption will probably result in a large increase in platinum prices until supply is resumed. This will increase the cost of new PAFC power plants and replacement fuel cell stacks. A doubling of the platinum price of \$475/tr. oz., would increase the cost of replacement stacks by 2.0 percent or less, and increase the initial capital cost of new PAFC power plants by 6.2 to 8.3 percent.

5.4 STUDY CONCLUSIONS

Adequacy of World Platinum Supply - The world platinum producers can market sufficient quantities of primary platinum metal to meet all demands, including the demand of PAFC commercialization, for the rest of this century and beyond. World demand for primary platinum is expected to grow at an annual rate of about 3.0 percent during 1978-2000. The platinum demand of PAFC commercialization is projected to increase world annual demand by only 2.2 to 5.7 percent during these years. Existing world reserves of platinum are large enough to last for more than 192 years at 1978 production levels and more than 116 years at projected year 2000 production levels. The platinum producers have demonstrated an ability in the past to expand their output rapidly to meet sudden increases in demand. The moderate growth rate projected for world platinum demand and the relatively small increase that PAFC commercialization will add to this demand should not overly stress the ability of the platinum producers to keep pace with demand.

The United States imports nearly all of its primary platinum directly or indirectly from the Republic of South Africa and thus is very vulnerable to platinum supply disruption. Although these imports have never been interrupted in the past, the potential exists in and around South Africa for political and social upheaval that could halt production for a prolonged period.

Platinum Prices Effects - The commercialization of PAFC power plants will probably produce a 3 to 6 percent increase in the price of platinum in the first year of commercialization over the price that would be demanded in the absence of PAFC market penetration. This increase could rise to a 4 to 8 percent range with high market penetration and high platinum use rates. After these short run price impacts, however, moderate shifts in platinum demand by PAFC commercialization will likely have little effect on the price of platinum since general economic conditions are likely to overshadow any further price impacts. The price of platinum appears to be determined more by general economic factors and precious metal speculation than by modest shifts in demand.

Power Plant Cost Effects - The projected 3 to 6 percent rise in platinum price during the first year of PAFC commercialization will raise the total initial capital costs of PAFC power plants by only 0.5 percent or less. Based on a price of \$475/tr. oz., the price of platinum would have to rise by 16.2 and 12.0 percent to cause even a 1.0 percent increase in the initial capital costs of multimegawatt and multikilowatt power plants, respectively. Hence, the initial capital costs of PAFC power plants are fairly insensitive to changes in platinum price. In addition, the overall capital costs of the power plants (costs that account for the periodic replacement of the fuel cell stacks) are even less sensitive to platinum price changes than the initial capital costs.

A disruption of platinum imports would likely result in a major increase in platinum price until supply is resumed. However, even a doubling of the \$475/tr. oz. price would induce only relatively small power plant cost increases: 2.0 percent or less for replacement fuel cell stacks and 6.2 to 8.3 percent for initial capital costs of new PAFC power plants.

Domestic industrial platinum inventories could meet U.S. demands during an import disruption lasting a maximum of four months, but longer disruptions would have to be met by programs of platinum conservation, recycling, and substitution. Development of domestic platinum resources could fulfill a large part of domestic demand but such development would take years to complete and would likely cause significant environmental impacts. PAFC research is studying catalytic substitutes for platinum and methods to reduce platinum loading. If platinum prices ever rise high enough to seriously impact the competitiveness of PAFC power plants, platinum substitutes and reduced platinum loadings would probably be employed to soften the impact.

ORIGINAL PAGE IS
OF POOR QUALITY