

**NASA
Technical
Paper
2201**

September 1983

**Fabrication and Evaluation
of Cold-Formed/Weld-Brazed
Beta-Titanium Skin-Stiffened
Compression Panels**

**Dick M. Royster,
Thomas T. Bales,
Randall C. Davis,
and H. Ross Wiant**

NASA



25th Anniversary
1958-1983

**NASA
Technical
Paper
2201**

1983

**Fabrication and Evaluation
of Cold-Formed/Weld-Brazed
Beta-Titanium Skin-Stiffened
Compression Panels**

**Dick M. Royster,
Thomas T. Bales,
and Randall C. Davis**
*Langley Research Center
Hampton, Virginia*

H. Ross Wiant
*Kentron International, Inc.
Hampton, Virginia*

NASA
National Aeronautics
and Space Administration
**Scientific and Technical
Information Branch**

The use of trade names in this publication does not constitute endorsement, either expressed or implied, by the National Aeronautics and Space Administration.

INTRODUCTION

Material requirements for advanced aircraft dictate increased use of more efficient materials and cost-effective fabrication techniques. Current use of titanium in aircraft has been deterred by high fabrication and machining costs. These costs are further aggravated by rising material and labor costs.

A family of titanium alloys that offers the potential to reduce fabrication costs is the all-beta titanium alloys. The beta titanium alloys are inherently cold-formable but have received relatively little use because of high springback after forming and low elongation after aging. However, a beta titanium alloy, Ti-15V-3Cr-3Al-3Sn (Ti-15-3), has been evaluated (ref. 1), and the preliminary data indicate that this alloy has excellent cold-formability and has properties that are an advantage over the properties of other beta titanium alloys. Ti-15-3 is continuous strip-producible, thus less costly than the alpha-beta titanium alloy, Ti-6Al-4V (Ti-6-4), which must be produced by hand mill. A recent study on Ti-15-3 (ref. 2) reported a 28-percent cost savings and a 16-percent weight savings by using a cold-formed beta titanium structure over a conventional Ti-6-4 hot-formed structure.

The objective of the research reported herein was to evaluate the performance at room temperature and elevated temperature of Ti-15-3 cold-formed stiffeners that were joined by the weld-brazing process (ref. 3) to Ti-6-4 skins to form compression panels. The stiffeners had a conventional hat-shaped configuration. A preliminary set of single-stiffener, 254-mm (10.0-in.) long compression panels was made to develop a data base for material and panel properties. The data from these preliminary panel tests include load-shortening curves, local buckling strengths, and failure loads. Comparisons were made between the test data from the room temperature tests and the elevated temperature tests. Material characterization tests on standard ASTM dogbone tensile specimens were made to substantiate results from the panel tests.

A final set of multi-stiffener compression panels 726 mm (28.6 in.) wide by 533 mm (21.0 in.) long were fabricated by the process developed for the single-stiffener compression panels 254 mm (10.0 in.) long. The overall geometrical dimensions for these panels were derived by the structural sizing computer code PASCO (ref. 4). For a given length and load, the code determines the number of stiffeners and the mass-optimum dimensions for the panel cross section. The multi-stiffener compression panels were tested at room temperature and similar data were obtained as those for the single-stiffener compression panels 254 mm long. The experimental buckling loads for the multi-stiffener panels were compared with the buckling loads calculated by the linked-strip analysis within the PASCO code.

PANEL FABRICATION

Material

The preliminary panels in this study were single-stiffener compression panels 254 mm (10.0 in.) long consisting of a cold-formed beta titanium alloy, Ti-15V-3Cr-3Al-3Sn (Ti-15-3), stiffeners joined by weld-brazing (WB) to titanium alloy, Ti-6Al-4V (Ti-6-4) skins. The Ti-15-3 material used for the stiffeners in

this investigation was 0.965-mm (0.038-in.) thick experimental grade sheet that was in the solution-treated condition during panel fabrication. The fabricated panels were then subjected to a thermal cycle to age the Ti-15-3 to obtain material properties suitable for aircraft use. The Ti-6-4 material used for the skins was commercial grade, hot-rolled, mill-annealed, 1.35-mm (0.053-in.) thick sheet.

Forming

Beta Ti-15-3 hat-shaped stiffeners were cold-formed in a power brake with the four bends either in the rolling direction of the sheet (longitudinal) or across the rolling direction (transverse). The radius of the bends in each stiffener was 3.175 mm (0.125 in.) or approximately 3 × Thickness. These bends were made with a 0.314-rad (18°) overbend to overcome springback. There was little or no evidence of orange peel on the surface in the bends. A typical formed stiffener 279 mm (11.0 in.) long is shown in figure 1.

Joining

After forming, the stiffeners were stress-relieved in a vacuum at 677°C (1250°F) for 5 min in an unrestrained position to alleviate residual forming stresses. The stiffeners were then chemically cleaned and spot-welded to Ti-6-4 skins with two rows of four spot-welds spaced 63.5 mm (2.50 in.) on each flange. The spot-welding parameters were developed such that weld nugget expansion resulted in a 0.051-mm (0.0020-in.) faying-surface gap between the stiffeners and skins. Strips of 3003 aluminum braze alloy 0.406 mm (0.0160 in.) thick were placed adjacent to the skin-stiffener joints and the assembly placed in the brazing furnace. The assembly was then heated to 677°C in a vacuum and held there for 5 min during which time the 3003 aluminum braze alloy melted and was drawn into the faying surface by capillary action. The panels were then cooled to room temperature and removed from the furnace. Nondestructive evaluation, including visual inspection and C scan, verified complete wetting between the stiffeners and skins and the establishment of good integral joints. A typical weld-brazed skin-stiffened panel is shown in figure 2. The panels were aged in air at 504°C (940°F) for 12 hr to obtain material properties suitable for aircraft use of the Ti-15-3 alloy. The material properties of the Ti-6-4 skins were not affected by the aging process. With this cold-formed/weld-brazed process, 12 single-stiffener compression panels were fabricated for testing at room temperature or at the elevated temperature of 316°C (600°F). Six of the panels had stiffeners formed in the longitudinal direction of the Ti-15-3 sheet and six had stiffeners formed in the transverse direction.

Potting

The fabricated panels were trimmed on the edges and ends and the ends potted using an epoxy material of either Hysol TE5467 for room temperature test panels or Epoxylite #813-9 for 316°C (600°F) elevated temperature test panels. The potting material was used to facilitate grinding the ends of the panels flat, parallel to each other, and perpendicular to the skins and for support during compression testing. The potting material for 316°C tests was cast around titanium clips that were spot-welded to the panel ends (ref. 5). The clips provided a mechanical lock

to prevent separation of the epoxy from the panels during cure or testing at 316°C caused by differences in thermal expansion between the titanium and the epoxy. A typical single-stiffener compression test panel was 254 mm (10.0 in.) long and 121 mm (4.75 in.) wide.

Process Scale-Up

The final panels in this study were multi-stiffener compression panels, 726 mm (28.6 in.) wide by 533 mm (21.0 in.) long, fabricated by the process used to fabricate the previously discussed single-stiffener compression panels 254 mm (10.0 in.) long. The beta Ti-15-3 stiffeners were cold-formed with the four bends of each stiffener in the rolling direction of the sheet to the configuration shown in figure 3. The stiffeners were spot-welded to the Ti-6-4 skin and the 3003 aluminum braze alloy strips were placed adjacent to the skin-stiffener joints at each end of the panel. The stiffeners were then brazed to the skin to fabricate a panel as shown in figure 4. Nondestructive evaluation using a C scan showed good aluminum braze wetting at the skin-stiffener interface following brazing. Three multi-stiffener compression panels were fabricated by the scaled-up process for the room temperature test only. The ends of the multi-stiffener panels were potted using the epoxy material Hysol TE5467 for machining the ends and for support during testing. A typical multi-stiffener compression test panel is shown in figure 5.

TEST PROCEDURE

The single-stiffener panels 254 mm (10.0 in.) long were loaded in compression along the stiffener axis using a 1.3-MN (300 kip) hydraulic testing machine. The unloaded edges of the specimens were supported with knife edge fixtures positioned 6.35 mm (0.250 in.) from the edge. Relative motion between the upper and lower platens of the testing machine was measured with linear variable differential transformers. Foil strain gages attached to the stiffener and skin were used to measure strain response in the panels. For the 316°C (600°F) tests, the foil strain gages had a phenolic reinforced backing, and they were attached to the panels with a polyimide adhesive. The strain gages were balanced at the test temperature, the platens of the test machine were brought into contact with the panels, and the panels were loaded to failure at a load rate of 89 N/s (1200 lbf/min). Data were recorded every 2 s prior to local instability and every second thereafter.

The single-stiffener panels for the 316°C (600°F) tests were heated radiantly with quartz lamps on both the skin and stiffener sides. A temperature survey on a representative panel was used to determine uniformity of heating. The survey indicated a temperature range of +28°C to -28°C (+50°F to -50°F) over the entire panel and a temperature range of +5°C to -5°C (+10°F to -10°F) in the strain-gage area. Panels were heated at a rate of 0.5°C/s (50°F/min) and held at temperature for 20 min prior to loading.

The multi-stiffener panels were loaded in compression along the stiffener axis by using a 5.34 MN-capacity (1 200 000-lb) universal hydraulic testing machine at a load rate of 1112 N/s (15 000 lbf/min). The test procedure used on the multi-stiffener compression panels was the same as that described for the single-stiffener compression panels.

RESULTS

Single-Stiffener Panels

Load shortening. - Typical load-shortening data obtained for the single-stiffener compression panels tested at room temperature and at 316°C (600°F) are shown in figure 6. The data show that the load-shortening curves for panels with stiffeners formed either in the longitudinal or transverse directions are nearly the same for the room temperature tests and for the 316°C tests. There is an approximate 14-percent difference between the extensional stiffnesses of the panel tests at room temperature and those at 316°C, as indicated by the initial slope of the load-shortening curves. This slope difference indicates that the material modulus is reduced by about 14 percent from the room temperature material modulus.

The panels were loaded until crippling of the skin and stiffener occurred. The crippling load is defined as the maximum load carried by the panel and is represented by termination of the load-shortening curves in figure 6 and tabulated in table I. As shown by the typical failures in figure 7, none of the panels tested exhibited a debond or separation between the stiffener and skin which is indicative of the good integrity of the weld-braze joint.

Buckling load. - The average buckling load for the single-stiffener panels tested at room temperature and 316°C (600°F) is shown in figure 8. The buckling load is defined as the load where the strain response reversed, as indicated by tabulated load and strain data from the strain gages located on the panels. The buckling load is tabulated in table I for each panel. The panels tested at room temperature for the conventional hat-shaped stiffeners formed in the longitudinal and transverse directions developed average buckling loads of 165 kN (37 179 lbf) and 175 kN (39 319 lbf), respectively. The panels tested at 316°C for the same stiffener configurations in the longitudinal and transverse directions developed average buckling loads of 144 kN (32 437 lbf) and 143 kN (32 194 lbf), respectively. A comparison of the data at room temperature and 316°C revealed that the average buckling load at 316°C is 13 and 18 percent less for the panels with the longitudinal and transverse stiffeners, respectively, than the average buckling load at room temperature.

The dashed lines in figure 8 indicate the predicted buckling loads calculated from the program entitled PASCO (ref. 4). The predicted buckling load at 316°C (600°F) is found by reducing the room temperature results by the 14-percent reduction in material modulus at 316°C. Agreement was excellent between the average experimental buckling loads and those derived analytically for the panels, the maximum difference being 7 percent.

In table II and represented graphically in figure 9 are data from standard ASTM dogbone test specimens made from the same titanium sheet material used to fabricate the stiffeners and skins of the panels in the current study. Prior to testing, the tensile specimens were thermally exposed to temperatures and times to simulate the aging and weld-brazing cycles of the compression panels. The data show the differences in modulus of elasticity and yield strength between the tests at room temperature and 316°C (600°F) for both the beta Ti-15-3 and Ti-6-4. The effect of the temperature reduced the modulus of elasticity for the beta Ti-15-3 and the Ti-6-4 by 3 and 6 percent, respectively, which is less than the 14 percent found from the compression panel load-shortening curves. The effect of temperature reduced the yield strength of the Ti-6-4 by 31 percent, which is a greater reduction than the 16-percent reduction for the beta Ti-15-3. In conjunction with the 0.2-percent offset strain for the stress-strain curves of figure 9, the average

buckling strains in table I show that the compression panels buckled elastically for both the room temperature and 316°C tests.

Multi-Stiffener Panels

The load-shortening curves for the three multi-stiffener compression panels tested at room temperature are shown in figure 10. The curves show good repeatability in the data from the three panels. Failure of the panels occurred by crippling of the stiffeners as depicted by the photograph of a typical failed panel in figure 11. None of the panels tested exhibited a debond or separation between the stiffeners and skin after testing.

An analysis of the strain-gage response data revealed evidence of local and general instability occurring nearly simultaneously near the crippling load. In figure 12 is shown a typical strain-gage response curve with the strain divided by the predicted buckling strain of 0.00489 and the panel load divided by the predicted buckling load of 871 kN (195 853 lb). The responses of the strain gages lie along the line from the origin through the point of intersection of buckling load and buckling strain; this indicates that the experimental extensional stiffness of the panel was very close to the predicted value. The occurrence of local buckling of the hat stiffener caps and webs, as evidenced by the reversal in the strain response curve, causes a reduction in cap stiffness which in turn causes a reduction in overall buckling stiffness. As a result, the development of local buckling modes in the stiffeners precedes a crippling or general instability failure of the entire panel.

The experimental buckling load for each multi-stiffener panel as well as the predicted buckling load from the program PASCO is shown in figure 13 and also tabulated in table III. The graphical comparison between predicted and experimental buckling loads indicate that the buckling loads are higher than the experimental values. The experimental values range from approximately 89 to 99 percent of the predicted value which is excellent agreement.

Metallurgical Investigation

The microstructures shown in figure 14 are representative for the beta Ti-15-3 material either in the as-received condition, longitudinal direction (fig. 14(a)) and transverse direction (fig. 14(b)), or following thermal exposures simulating stress relieving, brazing, and aging, longitudinal direction (fig. 14(c)) and transverse direction (fig. 14(d)). The microstructure in the longitudinal direction or the transverse direction appears to be similar; this correlates with the similarity of the panel data in table I and tensile data in table II for the two directions. The effect of stress relieving, brazing, and aging on the microstructure of the beta Ti-15-3 material was to change from an all-beta microstructure to an alpha-beta microstructure. This resulted in a 50-percent increase in material strength and a 50-percent decrease in elongation.

Typical metallurgical cross sections of a weld-braze joint are shown in figure 15. The braze alloy, which was placed adjacent to the flange of the stiffener, has penetrated completely through the joint coming into contact with the spot-weld (fig. 15(a)). The higher magnification of the braze joint (fig. 15(b)) shows little or no reaction between the titanium and aluminum braze alloy.

CONCLUDING REMARKS

Hat-shaped stiffeners were successfully cold-formed from the all-beta titanium alloy, Ti-15V-3Cr-3Al-3Sn, and joined by the weld-brazing process to alpha-beta titanium alloy, Ti-6Al-4V, skins to fabricate single-stiffener compression panels, 254 mm (10.0 in.) long. Stiffeners were cold-formed with a bend radius of $3 \times$ Thickness in either the longitudinal or transverse direction of the sheet and showed little or no evidence of orange peel in the bends. Panels were tested at room temperature and at 316°C (600°F) under in-plane compression in the direction of the stiffeners. The panels tested at 316°C buckled at loads about 18 percent lower than those tested at room temperature. There were no significant differences in panel stiffness or buckling strength for the panels with stiffeners formed in either the longitudinal or transverse direction. The panels continued to carry load after buckling until they failed by crippling. There were no debonds or separations of the stiffener-skin joints showing the good integrity of the weld-braze joining process.

The single-stiffener panel fabrication process was successfully scaled-up to fabricate multi-stiffener compression panels, 726 mm (28.6 in.) wide by 533 mm (21.0 in.) long, for room temperature tests. Agreement was excellent between the experimental buckling loads and those derived analytically for the panels by using the linear elastic linked-strip analysis computer program PASCO.

Langley Research Center
National Aeronautics and Space Administration
Hampton, VA 23665
August 1, 1983

REFERENCES

1. Lenning, G.: Formable Sheet Titanium Alloys. AFML-TR-76-45, U.S. Air Force, Aug. 1976. (Available from DTIC as AD A033 187.)
2. Kaneko, R. S.; Davis, G. W.; Woods, C. A.; and Royster, D. M.: Low Cost Fabrication of Sheet Structure Using a New Beta Titanium Alloy, Ti-15V-3Cr-3Al-3Sn. Materials Overview for 1982, Volume 27 of National SAMPE Symposium and Exhibition, Soc. Advance. Mater. & Process Eng., May 1982, pp. 589-604.
3. Bales, Thomas T.; Royster, Dick M.; and Arnold, Winfrey E., Jr.: Development of the Weld-Braze Joining Process. NASA TN D-7281, 1973.
4. Anderson, Melvin S.; and Stroud, W. Jefferson: A General Panel Sizing Computer Code and Its Application to Composite Structural Panels. AIAA J., vol. 17, no. 8, Aug. 1979, pp. 892-897.
5. Royster, Dick M.; and Shearin, W. Albert, Jr.: J-Channel Locks Potting to Compression Panel. NASA Tech Brief LAR-12913, 1983.

TABLE I.- COLD-FORMED/WELD-BRAZED SINGLE-STIFFENER COMPRESSION PANEL DATA

Panel (a)	Buckling load		Average strain at buckling, in/in.	Crippling load		Predicted buckling load	
	kN	lbf		kN	lbf	kN	lbf
Tests at room temperature							
1L	166	37 411	0.00463	249	55 943	163	36 665
2L	159	35 708	.00435	249	55 975	163	36 665
3L	171	38 419	.00471	253	56 821	163	36 665
1T	167	37 443	.00462	254	57 179	163	36 665
2T	163	36 576	.00478	255	57 369	163	36 665
3T	195	43 939	.00520	265	59 512	163	36 665
Tests at 316°C (600°F)							
4L	169	37 921	0.00549	201	45 298	140	31 532
5L	134	30 123	.00472	187	42 127	140	31 532
6L	127	28 539	.00450	182	40 961	140	31 532
4T	165	37 126	.00542	204	45 930	140	31 532
5T	143	32 146	.00492	190	42 781	140	31 532
6T	125	28 038	.00433	188	42 182	140	31 532

^aL indicates stiffener formed with the bends in sheet roll (longitudinal) direction; T indicates stiffener formed with the bends across sheet roll (transverse) direction.

TABLE II.- TENSILE PROPERTIES OF Ti-15V-3Cr-3Al-3Sn AND Ti-6Al-4V SHEET MATERIALS

Specimen (a)	Cross-sectional area		Yield stress		Maximum stress		Modulus of elasticity	
	cm ²	in ²	MPa	ksi	MPa	ksi	GPa	ksi
Ti-15V-3Cr-3Al-3Sn ^b at room temperature								
1L	0.117	0.0182	1118	162.1	1231	178.5	110	16 000
2L	.116	.0180	1126	163.3	1229	178.3	112	16 200
3L	.114	.0176	1132	164.2	1240	179.8	112	16 200
1T	.119	.0185	1137	164.9	1247	180.8	112	16 200
2T	.124	.0192	1140	165.4	1246	180.7	112	16 300
3T	.124	.0193	1143	165.8	1243	180.3	112	16 200
Ti-15V-3Cr-3Al-3Sn ^b at 316°C (600°F)								
4L	0.113	0.0175	945	137.0	1057	153.1	111	16 100
5L	.115	.0179			1057	153.1	110	15 900
6L	.114	.0177	943	136.7	1095	158.8	112	16 200
4T	.123	.0191	978	141.9	1119	162.3	114	16 500
5T	.123	.0190			1071	155.3	107	15 500
6T	.122	.0189			1069	155.0	113	16 400
Ti-6Al-4V ^c at room temperature								
7L	0.158	0.0245	992	143.9	1083	157.1	111	16 100
8L	.160	.0248	993	144.0	1082	156.9	116	16 800
9L	.163	.0252	978	141.9	1076	156.0	114	16 500
Ti-6Al-4V ^c at 316°C (600°F)								
10L	0.161	0.0249			814	118.1	108	15 700
11L	.161	.0250	676	98.0	807	117.0	108	15 600
12L	.160	.0248			806	116.9	108	15 600

^aL indicates longitudinal tensile specimens; T indicates transverse tensile specimens.

^bTensile specimens were thermally exposed to simulate temperatures and times associated with stress relieving, brazing, and aging test panels.

^cTensile specimens were thermally exposed to simulate temperatures and times associated with brazing and aging test panels.

TABLE III.-- COLD-FORMED/WELD-BRAZED MULTI-STIFFENER COMPRESSION PANEL DATA

Panel	Buckling load		Average strain at buckling, in/in.	Crippling load at buckling		Predicted buckling load	
	kN	lbf		kN	lbf	kN	lbf
1	866	194 684	0.00452	1070	240 491	871	195 853
2	773	173 831	.00424	1016	228 356	871	195 853
3	782	175 711	.00421	1060	238 269	871	195 853

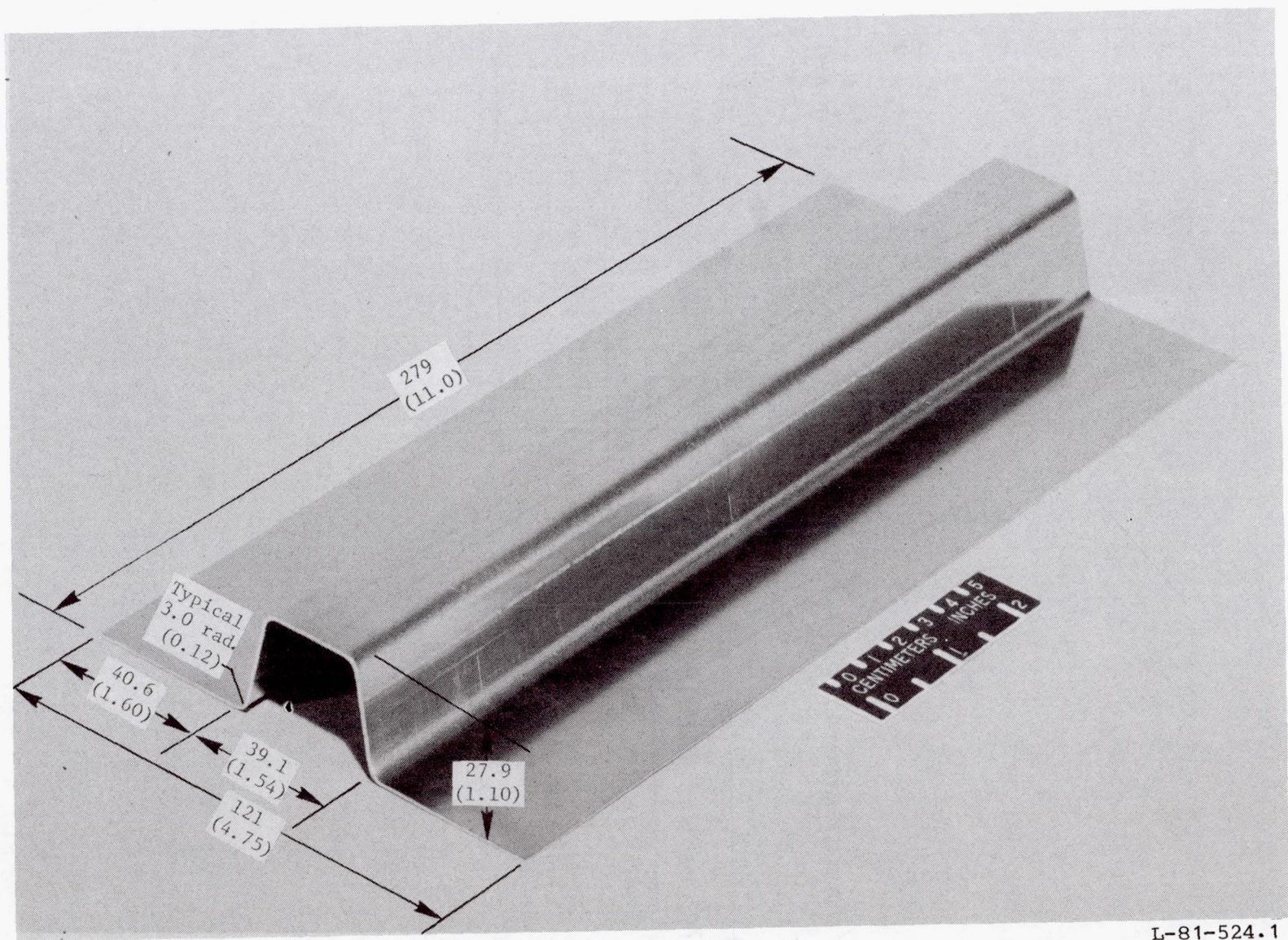

L-81-524.1

Figure 1.- Cold-formed beta Ti-15-3 stiffener. Dimensions are in millimeters (inches).

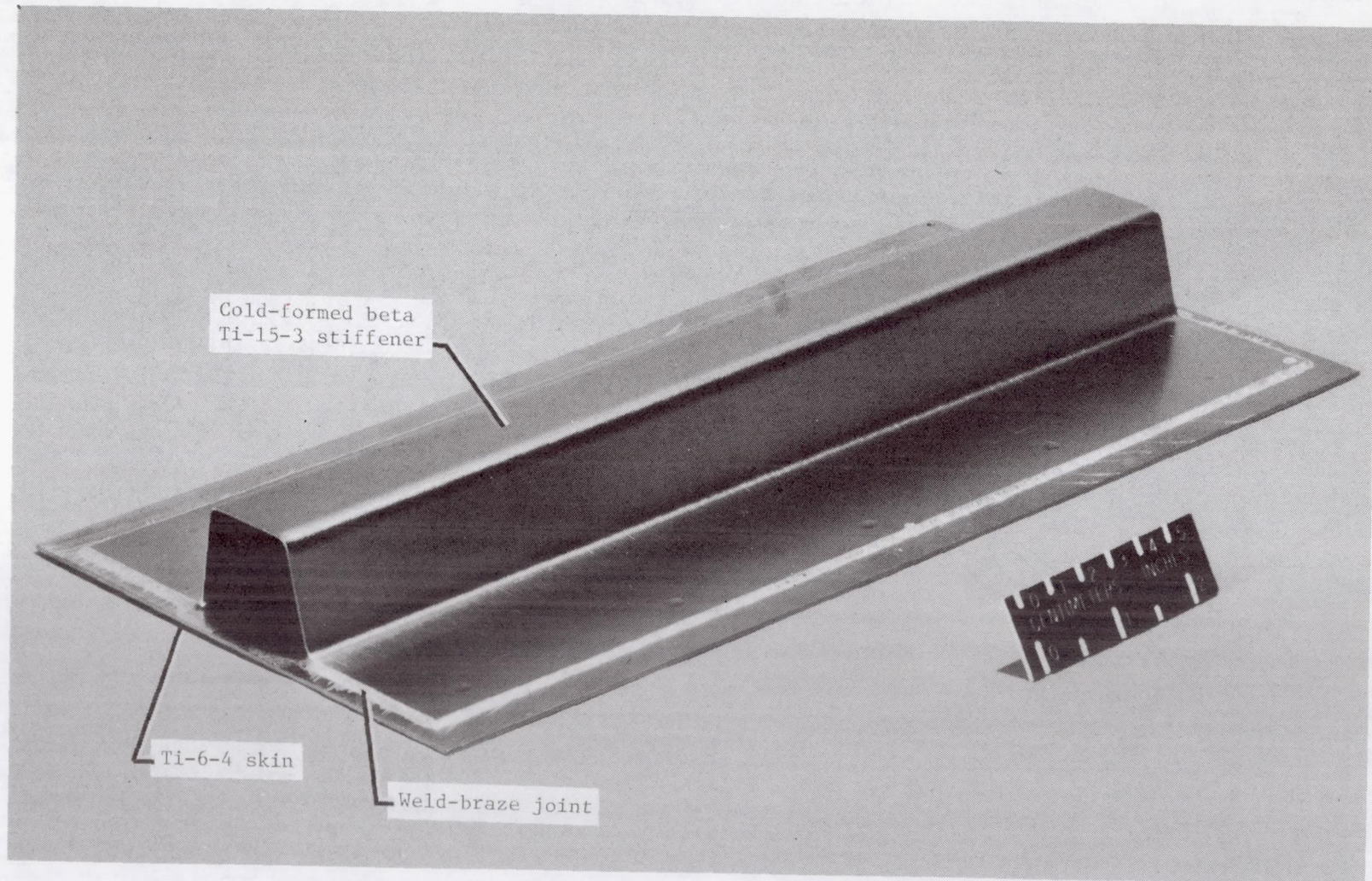

Figure 2.- Panel assembly after brazing and before trimming.

L-81-2640.1

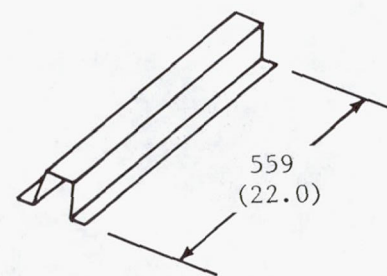
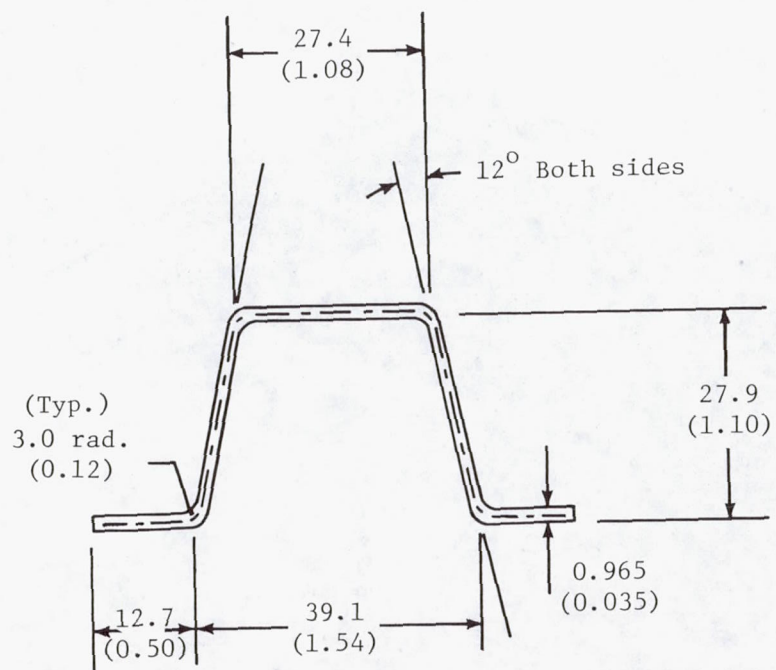

Figure 3.- Configuration of beta Ti-15-3 cold-formed stiffener for multi-stiffener panels.
Dimensions are in millimeters (inches).

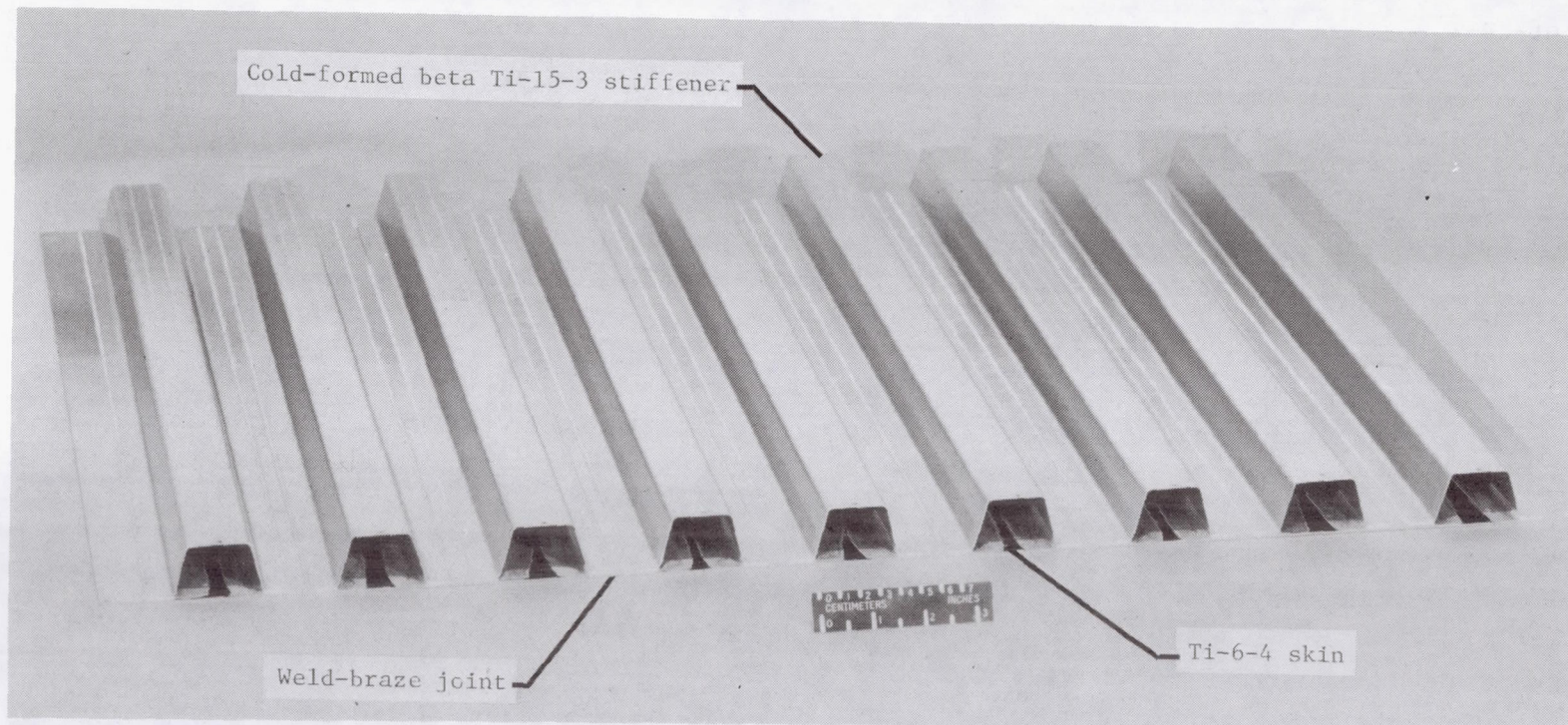
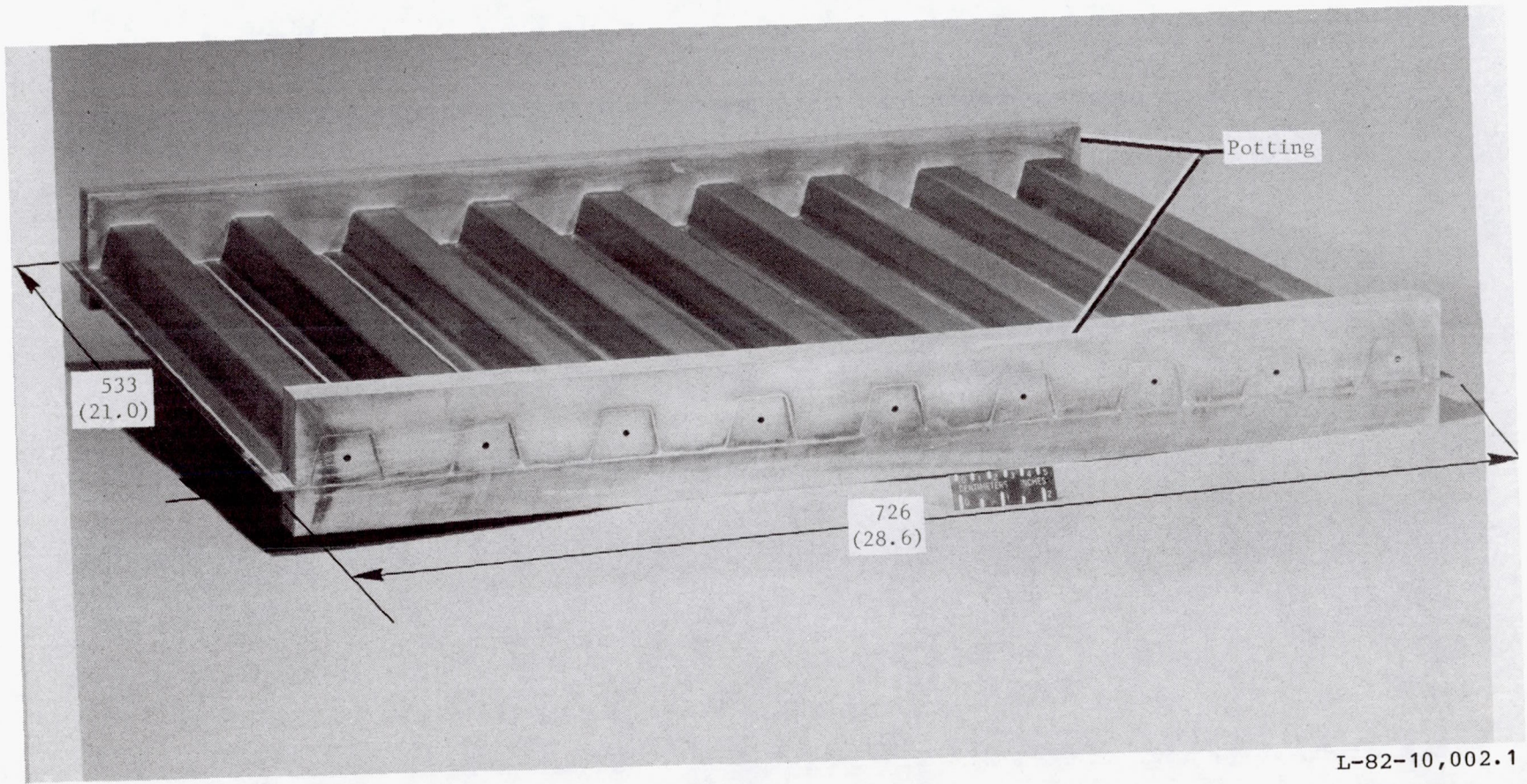

Figure 4.- Multi-stiffener panel assembly after brazing and before trimming.

L-82-5306.1



L-82-10,002.1

Figure 5.- Multi-stiffener test panel trimmed and potted for test. Dimensions are in millimeters (inches).

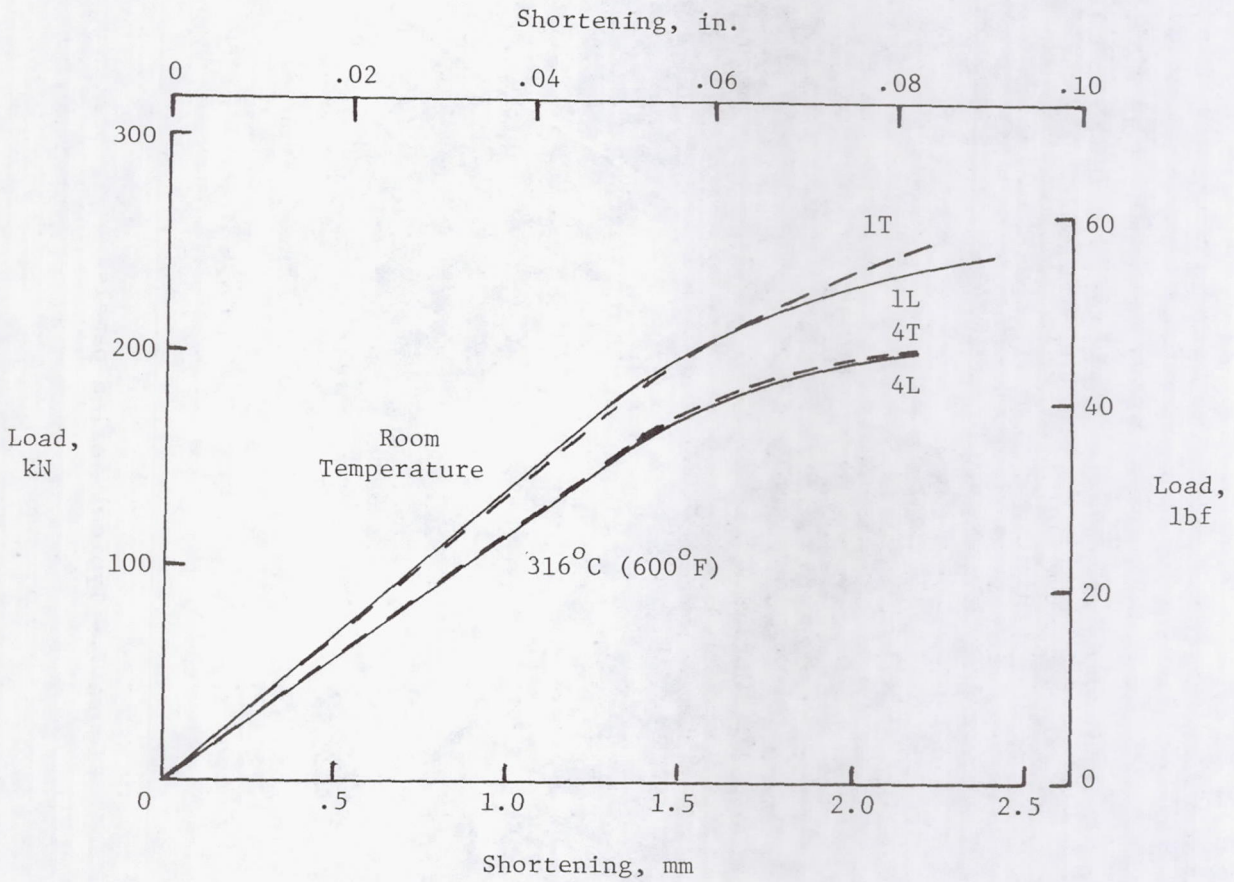
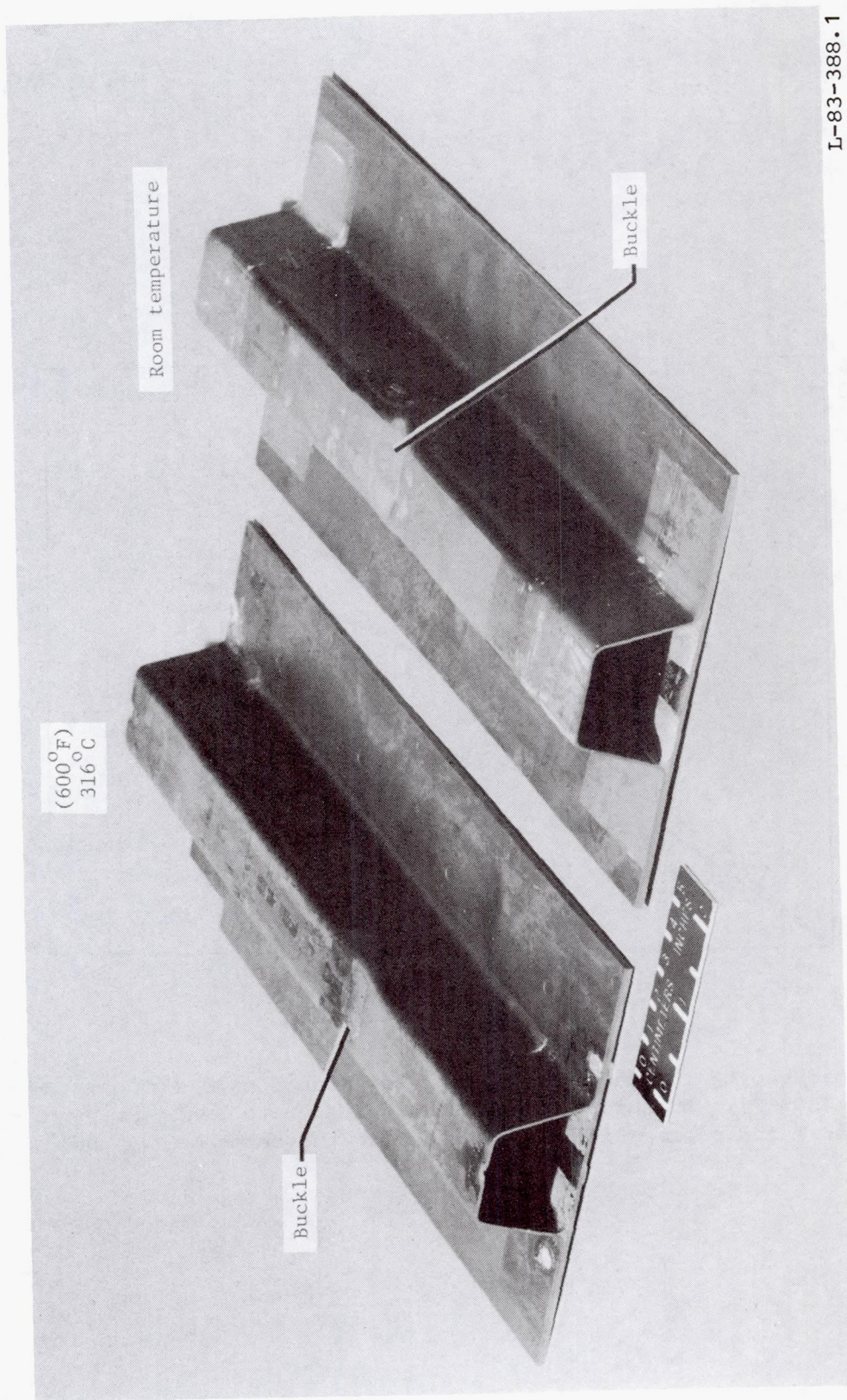
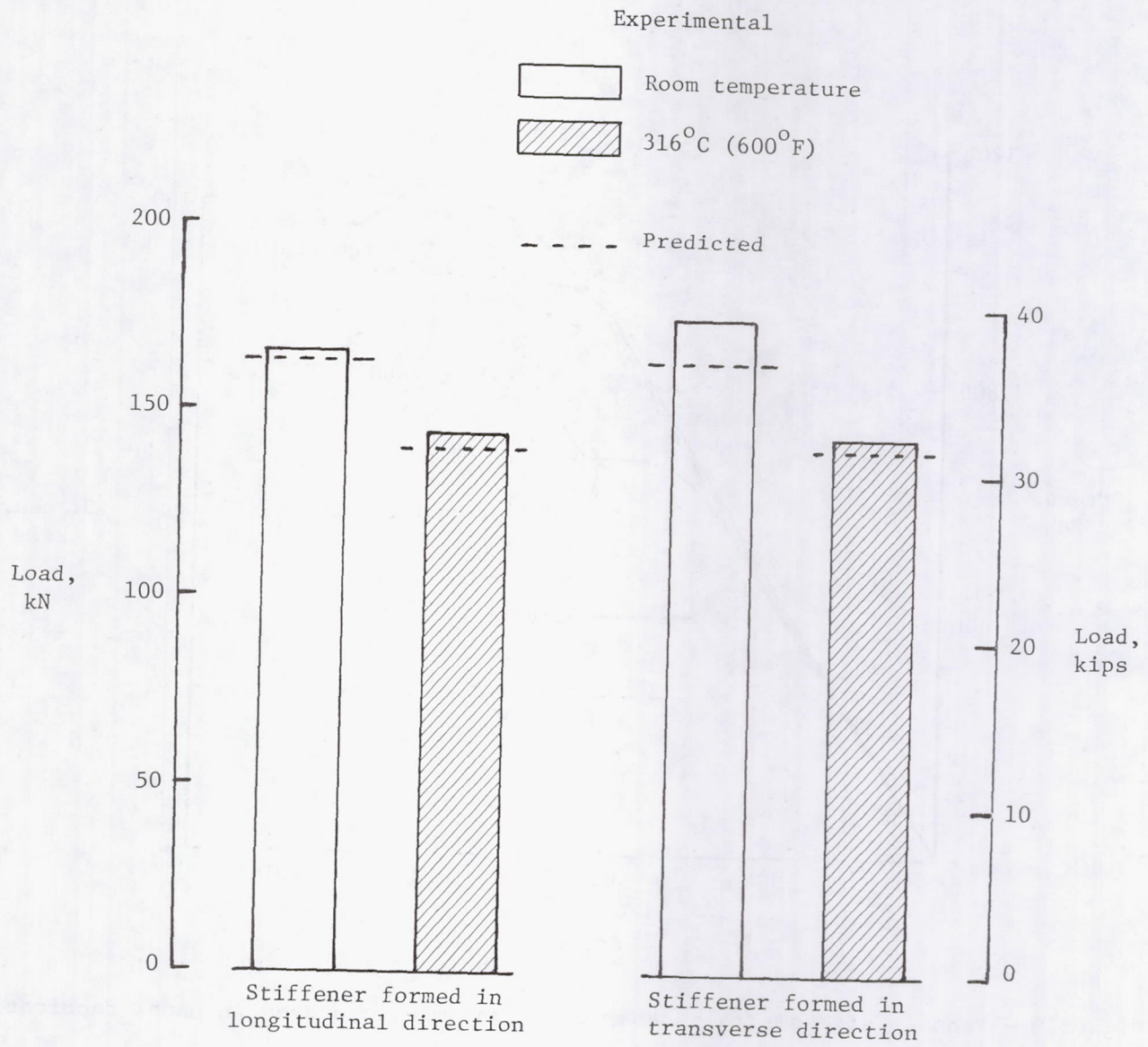

Figure 6.- Load-shortening curves for single-stiffener panels at room temperature and 316°C (600°F). L indicates stiffener formed with bends in sheet roll directions; T indicates stiffener formed with the bends across sheet roll direction.



L-83-388.1

Figure 7.- Typical failed panels.



----- Predicted

Figure 8.- Average buckling loads of skin-stiffened panels.

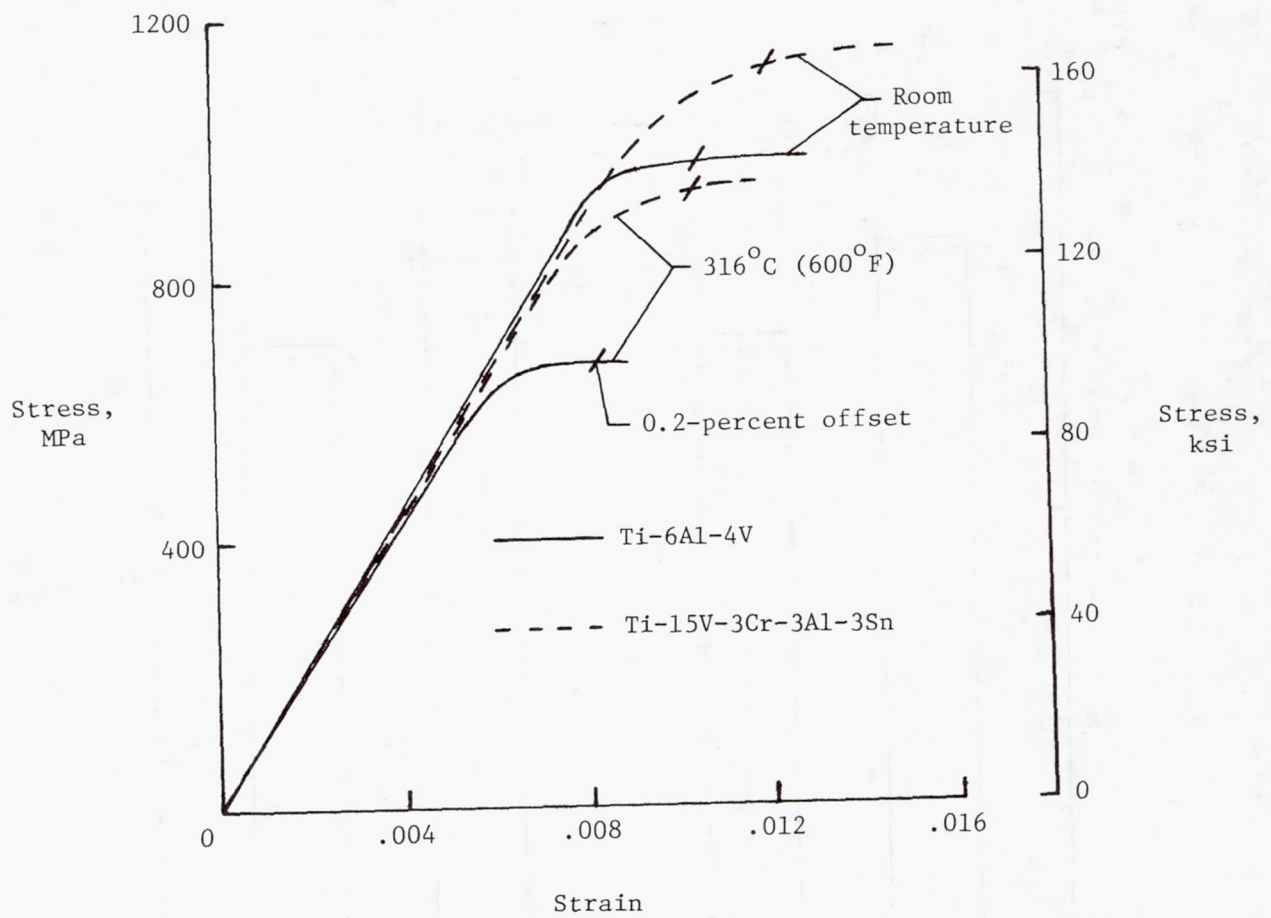

Figure 9.- Tensile stress-strain data for titanium alloys used in panel fabrication.

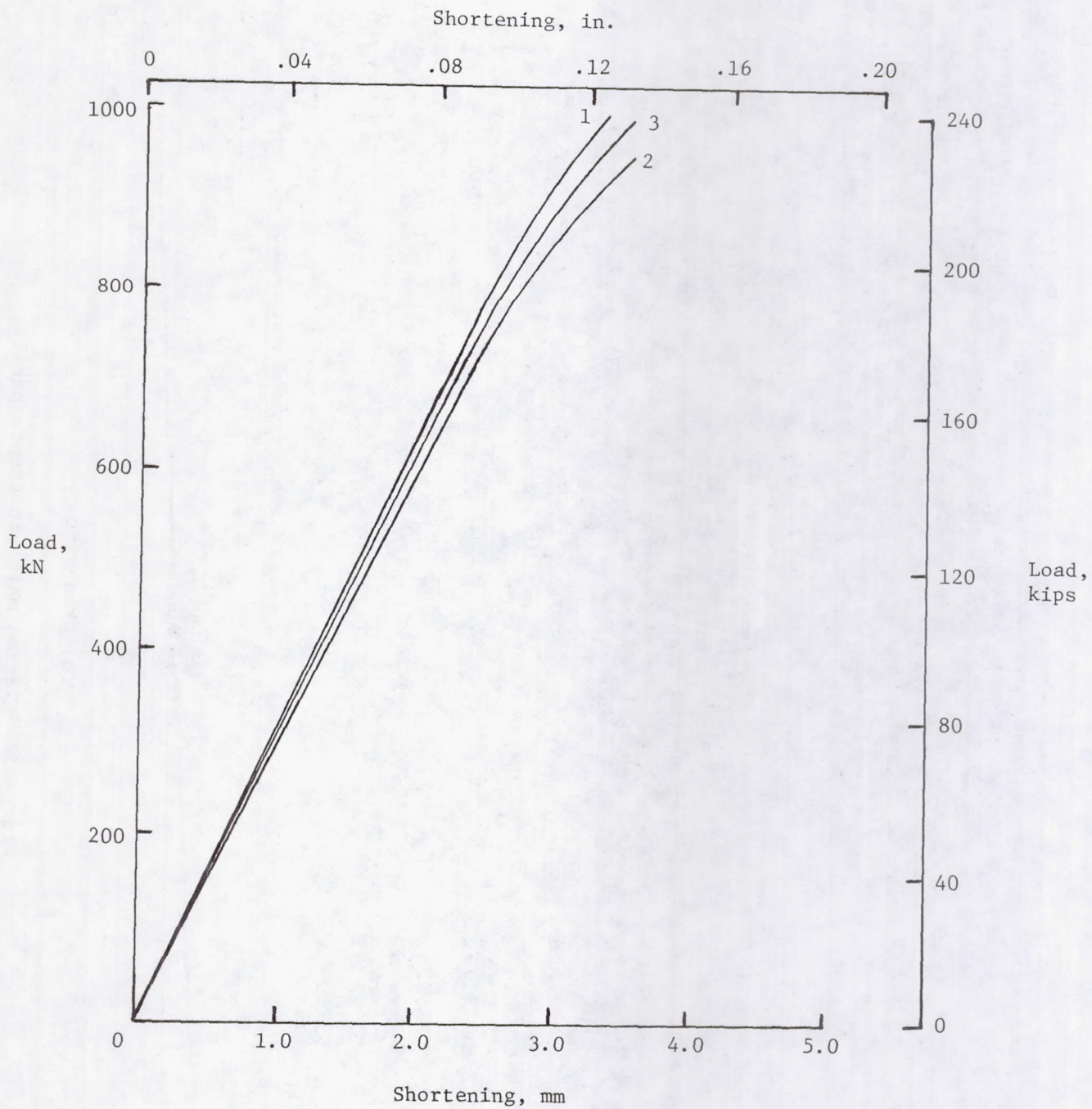
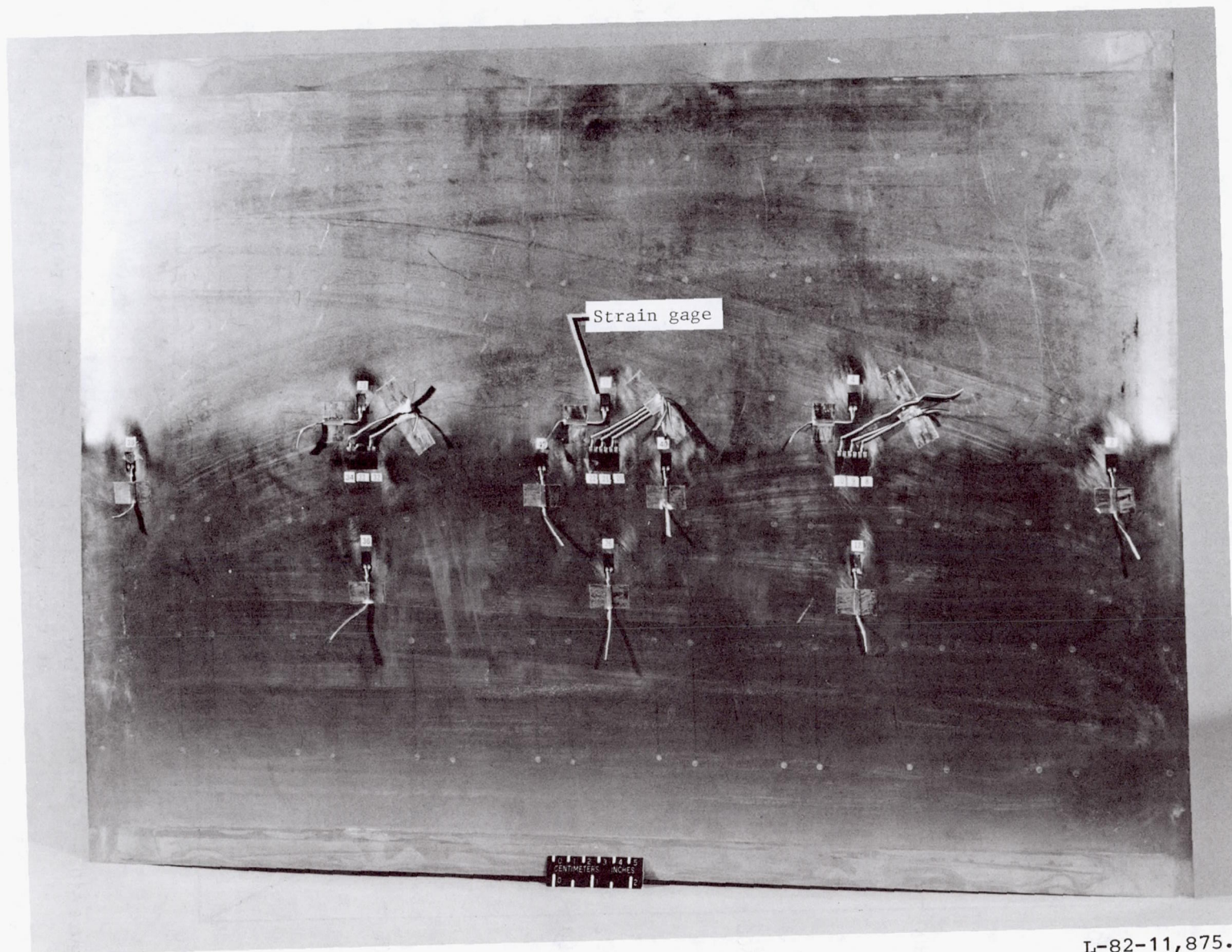

Figure 10.- Load-shortening curves for multi-stiffener panels tested at room temperature.



L-82-11,875.1

(a) Skin side.

Figure 11.- Tested multi-stiffener panel.

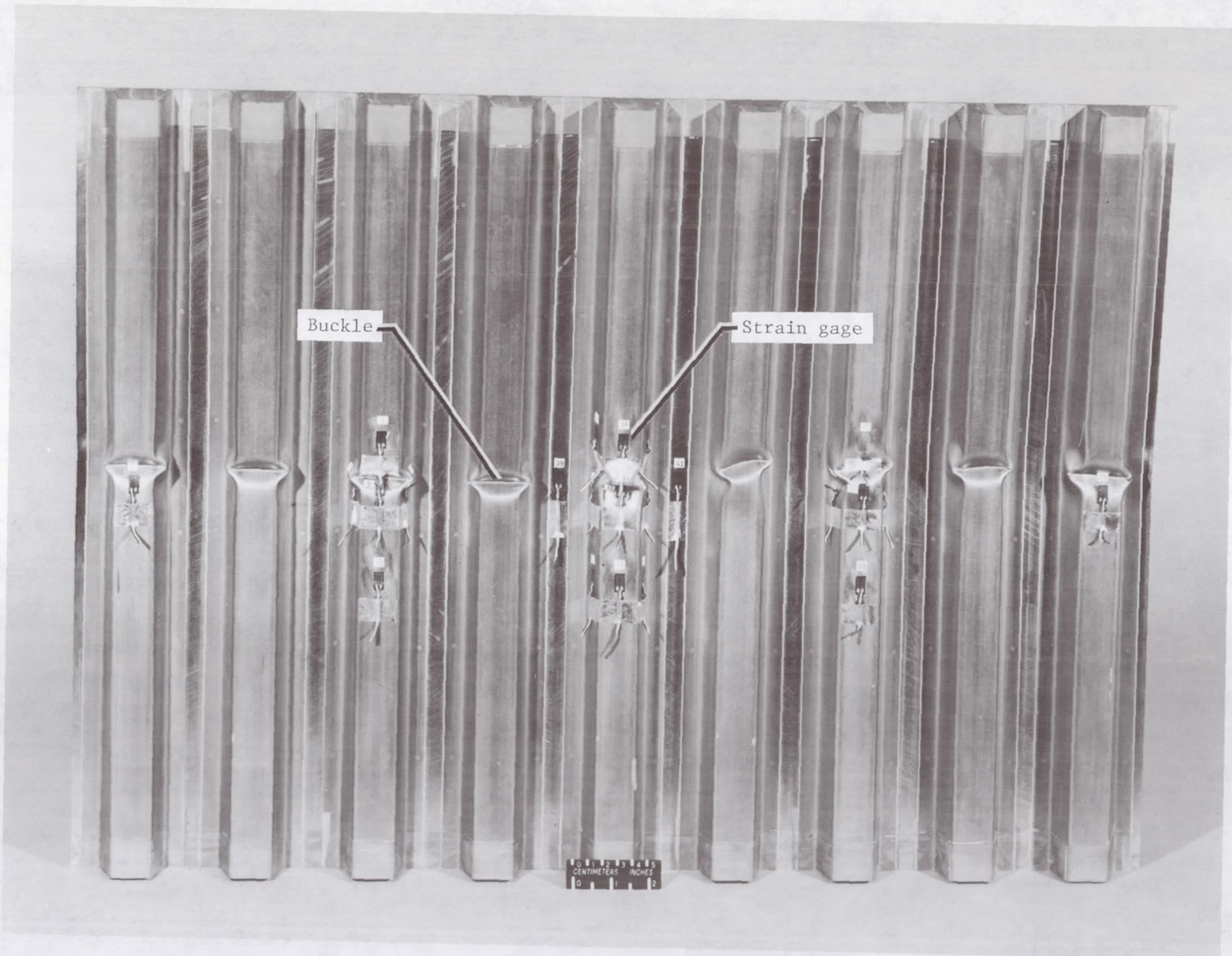

(b) Stiffener side.

L-82-11,876.1

Figure 11.- Concluded.

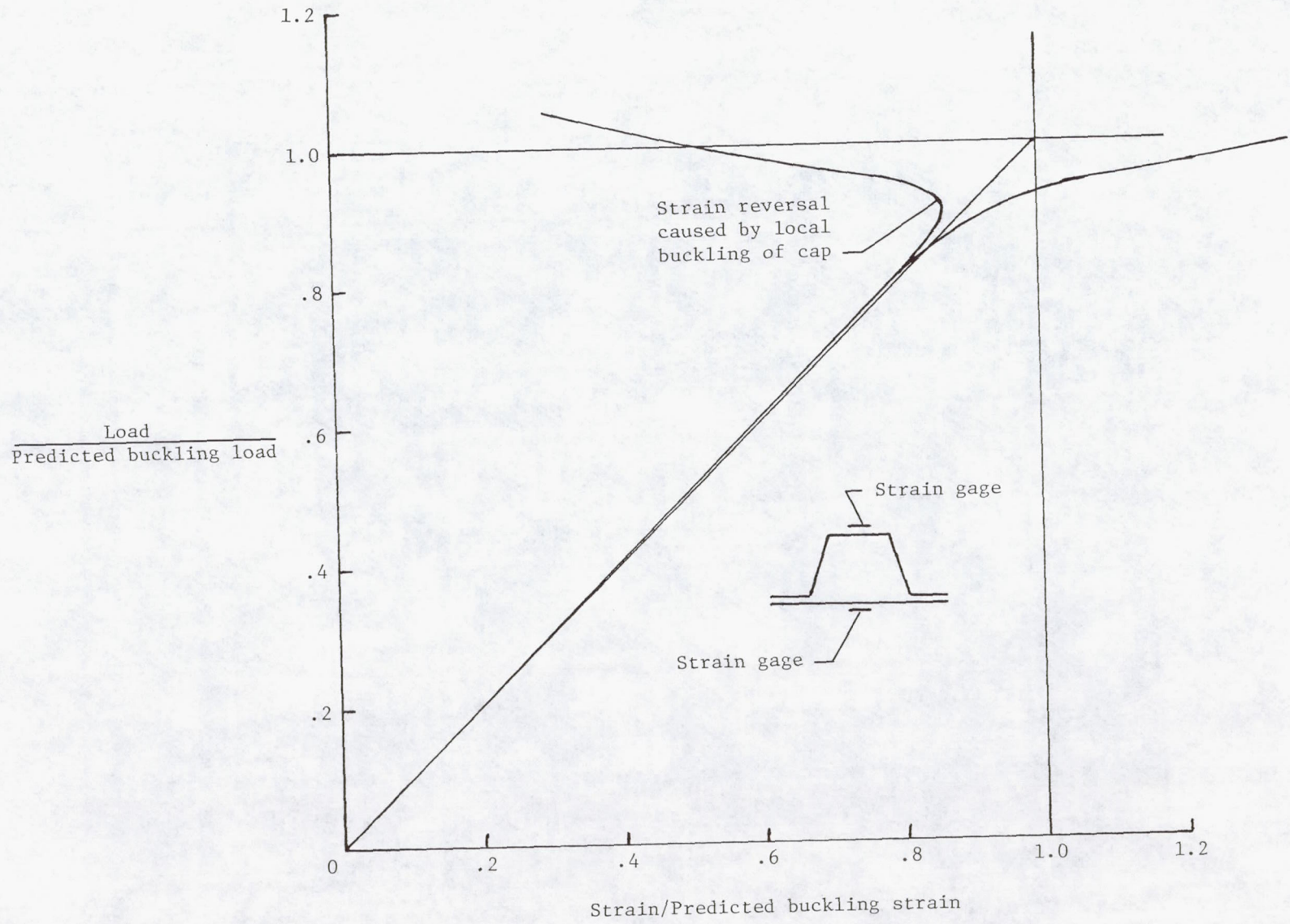

Figure 12.- Typical back-to-back strain gage response for multi-stiffener panels.

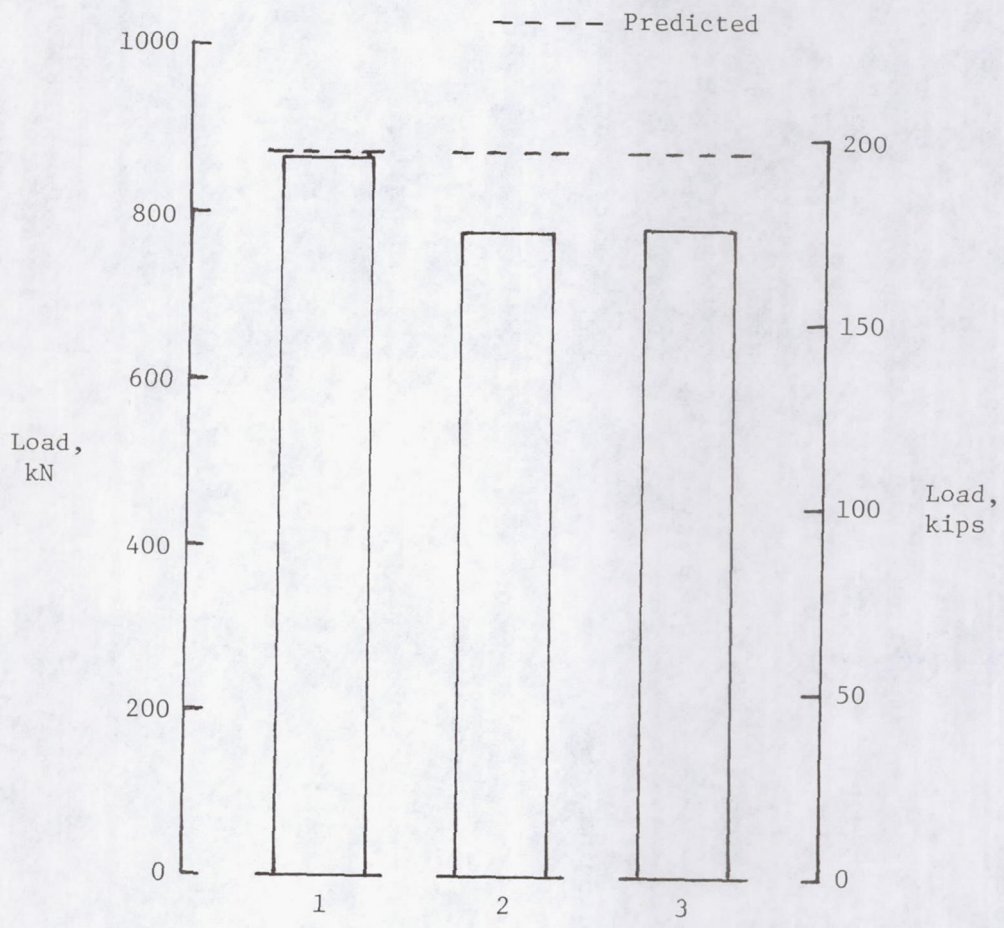

Figure 13.- Room temperature buckling loads of multi-stiffener panels.



(a) As-received; longitudinal direction.



(b) As-received; transverse direction.

↑
51 μm
(.002 in.)
↓

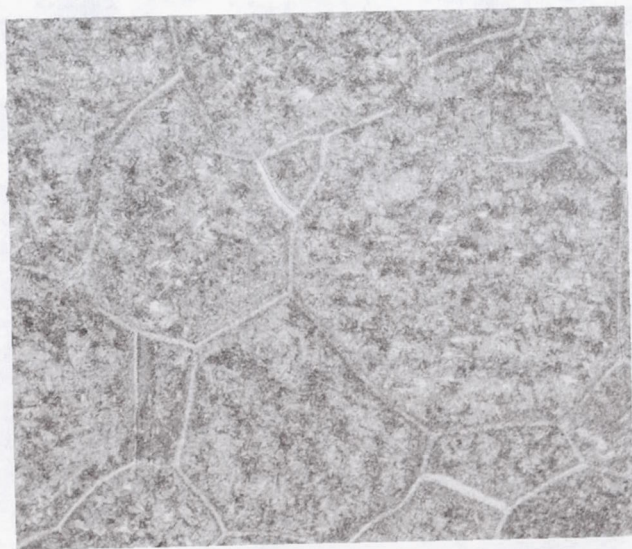

(c) Thermally exposed to simulate stress relieving, brazing, and aging; longitudinal direction.

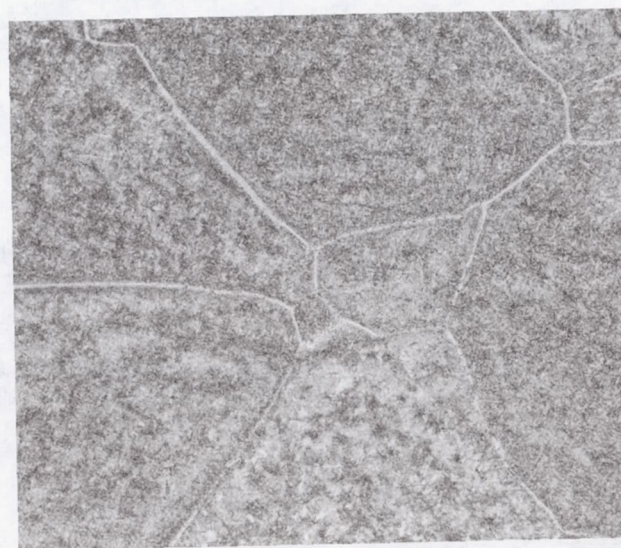

(d) Thermally exposed to simulate stress relieving, brazing, and aging; transverse direction.

L-83-105

Figure 14.- Photomicrographs of beta Ti-15-3 alloy.

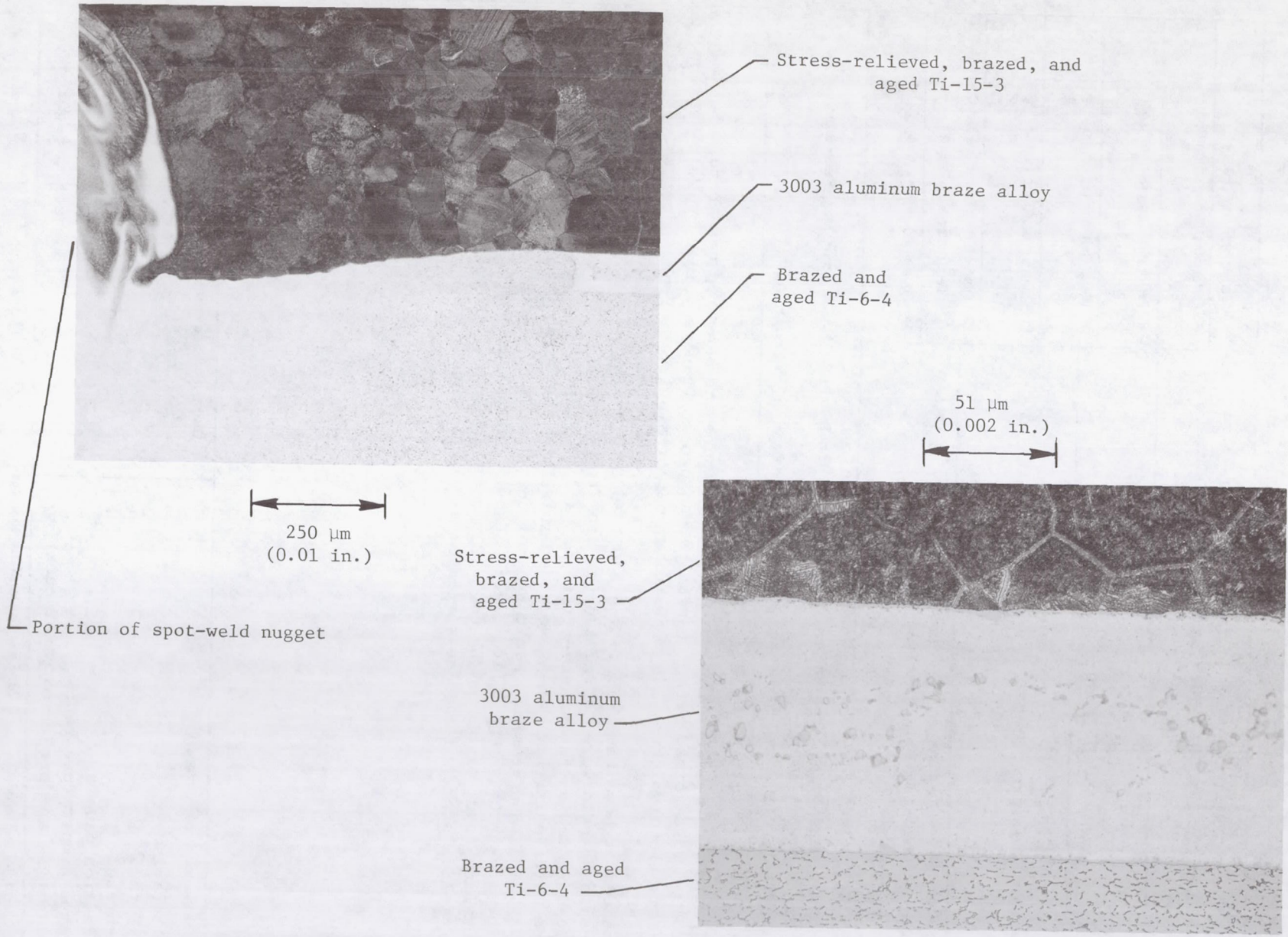

(a) Spot-weld-braze joint.

(b) Braze joint.

L-83-106

Figure 15.- Cross sections of weld-braze joint.

1. Report No. NASA TP-2201	2. Government Accession No.	3. Recipient's Catalog No.
4. Title and Subtitle FABRICATION AND EVALUATION OF COLD-FORMED/WELD-BRAZED BETA-TITANIUM SKIN-STIFFENED COMPRESSION PANELS		5. Report Date September 1983
		6. Performing Organization Code 505-43-43-06
7. Author(s) Dick M. Royster, Thomas T. Bales, Randall C. Davis, and H. Ross Wiant		8. Performing Organization Report No. L-15634
		10. Work Unit No.
9. Performing Organization Name and Address NASA Langley Research Center Hampton, VA 23665		11. Contract or Grant No.
		13. Type of Report and Period Covered Technical Paper
12. Sponsoring Agency Name and Address National Aeronautics and Space Administration Washington, DC 20546		14. Sponsoring Agency Code
15. Supplementary Notes Dick M. Royster, Thomas T. Bales, and Randall C. Davis: NASA Langley Research Center, Hampton, Virginia. H. Ross Wiant: Kentron International, Inc., Hampton, Virginia.		
16. Abstract <p>A study was made to determine the room temperature and elevated temperature buckling behavior of cold-formed beta titanium hat-shaped stiffeners joined by weld-brazing to alpha-beta titanium skins. A preliminary set of single-stiffener compression panels were used to develop a data base for material and panel properties. These panels were tested at room temperature and 316°C (600°F). A final set of multi-stiffener compression panels were fabricated for room temperature tests by the process developed in making the single-stiffener panels. The overall geometrical dimensions for the multi-stiffener panels were determined by the structural sizing computer code PASCO. The data presented from the panel tests include load-shortening curves, local buckling strengths, and failure loads. Experimental buckling loads are compared with the buckling loads predicted by the PASCO code. Material property data obtained from tests of ASTM standard dogbone specimens are also presented.</p>		
17. Key Words (Suggested by Author(s)) Beta titanium Cold-formed Weld-brazed Compression panels Elevated temperature tests Experimental and predicted panel buckling		18. Distribution Statement Unclassified - Unlimited Subject Category 26
19. Security Classif. (of this report) Unclassified	20. Security Classif. (of this page) Unclassified	21. No. of Pages 27
		22. Price A03