

## HIGH-ACCURACY GLOBAL TIME AND FREQUENCY TRANSFER WITH A SPACE-BORNE HYDROGEN MASER CLOCK

R. Decher (NASA), D. W. Allan (NBS), C. O. Alley  
(U. of Maryland), C. Baugher (NASA), B. J. Duncan  
(NASA), R.F.C. Vessot (SAO), and G.M.R. Winkler (USNO)

### ABSTRACT

This paper describes a proposed system for high-accuracy global time and frequency transfer using a hydrogen maser clock in a space vehicle. Direct frequency transfer with an accuracy of  $10^{-14}$  and time transfer with an estimated accuracy of 1 nsec are provided by a 3-link microwave system. A short pulse laser system is included for subnanosecond time transfer and system calibration. The basic concept of such a system was discussed at the 1980 PTTI Meeting. This paper presents the results of further studies including operational aspects, error sources, data flow, system configuration, and implementation requirements for an initial demonstration experiment using the Space Shuttle.

### INTRODUCTION

NASA's Office of Space Science and Applications has supported a study of a space system for high-accuracy global time and frequency transfer which uses a hydrogen maser in a space vehicle. The concept of this system was presented at the Twelfth Annual PTTI meeting in 1980 and elsewhere (1). The present paper discusses the results of recent studies concerned with the implementation of a Space Shuttle demonstration experiment. The Shuttle experiment would be the first step toward a later operational system which would provide high-accuracy global time and frequency transfer on a more permanent basis.

The idea of the Space Time and Frequency Transfer (STIFT) system evolved from two earlier experiments performed several years ago to measure relativistic effects on clocks. In 1976, Gravitational Probe A (GP-A), a joint project of the Marshall Space Flight Center and the Smithsonian Astrophysical Observatory, carried a hydrogen maser clock into space to measure the gravitational redshift effect (2). The frequencies of the hydrogen maser clock in space and a ground-based hydrogen maser clock were compared with an accuracy of  $10^{-14}$  using a specially developed microwave system which provided automatic cancellation of the first-order Doppler effect (3). The technology and the system concepts demonstrated in this experiment are the basis for the STIFT microwave time and frequency transfer system.

In 1975 and 1976, the University of Maryland with support from the U.S. Navy carried out several airplane experiments to

measure relativistic effects on clocks by employing a short-pulse laser technique (4). The time comparison of the airborne and ground based clocks by laser pulses was accurate to about 0.2 ns. The same technique would be applied for the laser part of the STIFT system.

The STIFT concept combines the two proven techniques to provide a space clock facility for high accuracy global time and frequency transfer. Such a system could be implemented on a space station or with a satellite. A Space Shuttle experiment is proposed as the first phase of such a program to test and demonstrate system performance capabilities. With this goal a study of the operational aspects, accommodation and implementation requirements, and error sources for a Shuttle experiment has been performed. The results are summarized in this paper.

### Systems Description

The concept of the system is illustrated in Figure 1. Two widely separated clocks, A and B, are compared in time and frequency by means of an orbiting hydrogen maser clock which serves as a transfer standard. STIFT is composed of two independent systems, a microwave system which provides both time and frequency transfer and a short-pulse laser system for time transfer.

The microwave time and frequency transfer requires a ground terminal which receives signals from and transmits signals to the spacecraft. As the space clock passes over ground clock A, the two clocks are compared by microwave transmissions. The process is repeated when the space clock passes over ground clock B. Combination of the two measurements yields a comparison of clock A and B. The microwave system, which is similar to the system used with GP-A, provides automatic cancellation of the first-order Doppler effect and of propagation disturbances in the atmosphere. This technique permits very accurate direct frequency comparison which is a unique feature of the proposed system. Simultaneously with the frequency comparison, microwave time transfer is accomplished with PRN code modulation of the carrier frequencies and correlation techniques. The ( $1\sigma$ ) accuracy of the frequency comparison ( $\Delta f/f$ ) is known to be at least  $10^{-14}$  for 100-second measurement intervals, and the accuracy ( $\Delta t$ ) of the time transfer is estimated to be better than 1 nanosecond.

A simplified block diagram of the microwave system including the onboard system and the ground terminal is shown in Figure 2. The system transmits three CW, phase-coherent carrier signals at S-band. The frequencies shown are those used with GP-A and not necessarily the ones to be used in the proposed Shuttle experiment. A single antenna with a triplexer is used for all three frequencies.

The frequency comparison utilizes the phase information of the CW carrier signals. The onboard clock frequency ( $\approx 1420$  MHz) is converted to S-band (frequency ratio 76/49) and transmitted to the ground terminal. This clock downlink frequency experiences a one-way Doppler shift and phase changes due to propagation disturbances. The ground clock signal is first transmitted to the space vehicle and returned to the ground terminal by the onboard transponder to obtain a measurement of the two-way Doppler and propagation effects. Dividing the two-way frequency shifts by 2 and subtracting the result from the one-way clock downlink cancels the first-order Doppler and most of the propagation disturbances before the two clock frequencies are compared. The various frequency conversion ratios indicated in the diagram of Figure 2 are compatible with an existing commercial transponder design and are chosen to eliminate ionospheric dispersion encountered by the use of different carrier frequencies. The resulting difference frequency  $\Delta f$  between ground clock and space clock contains relativistic frequency shifts (second-order Doppler and gravitational redshift) which are accounted for by calculations utilizing orbit data.

Time transfer is accomplished by the shaded functional blocks in the diagram (Figure 2) which represent an addition to the original GP-A system concept. The time code of the space clock is modulated on the clock downlink carrier using PRN phase modulation (5). The space clock time code received at the ground terminal is correlated with the ground clock time code to measure the time difference  $\Delta t$  which contains the one-way propagation delay. A range code modulation of the transponder link provides a two-way propagation delay measurement which is used to eliminate the one-way propagation delay.

The microwave system is relatively insensitive to adverse weather conditions (which can affect the laser system) and is therefore the primary mode of time and frequency transfer for an operational STIFT system. The user of such a system will require a comparatively inexpensive ground terminal which fits into a standard size instrument rack to interface with his clock. A microwave antenna with hemispherical coverage is part of the ground terminal.

The STIFT system can also perform time transfer using short-pulse laser techniques. The laser time transfer, which is independent of the microwave system, will be used with existing laser stations around the world. A block diagram of the laser time transfer method is shown in Figure 3. The onboard system is comprised of a corner-cube reflector array equipped with fast photodiode detectors and an event timer interfacing with the hydrogen maser clock. The laser pulse signal is returned to the ground station by the reflector array and is detected on board simultaneously by photo detectors. The event timer measures the

arrival time  $T_2$  of the laser pulse at the space vehicle in the time frame of the onboard clock. This information is transmitted to the ground station by telemetry. The ground station determines the round trip time of the laser pulse and the midpoint time  $(T_3 - T_1)/2$  between transmitted and received pulse. The difference between this midpoint and the time  $T_2$  gives the time difference between ground clock and space clock. Relativistic corrections must also be applied to laser time transfer.

The short-pulse laser technique is the most accurate method of time transfer available. It provides an important extension of the capabilities of the microwave system and will be valuable for calibration of the microwave system (6). Simultaneous use of microwave and laser time transfer will provide a comparative evaluation of the two different techniques.

### Space Shuttle Experiment

The ultimate application of the proposed STIFT technique is an operational space system which serves a global user community. A Space Shuttle experiment is proposed as a first step toward this goal. The Shuttle experiment will demonstrate and verify the performance of the system and provide the opportunity to optimize the system design for a later operational use. The experiment can be reflown, and, with relocation of ground terminals, increased user participation is possible. The Shuttle experiment could serve also as a test bed for testing atomic clocks intended for space applications.

Figure 4 illustrates the concept of packaging for the experiment flight instrument. All components are integrated into a modularized, self-contained assembly with minimal interfaces to the spacecraft. The dome on top of the assembly shows one of several antenna concepts consisting of a phased array of S-band elements combined with an interspersed array of corner-cube reflectors for the laser link. The assembly is mounted on a pallet in the Shuttle payload bay and deployed by the manipulator arm during operation. Deployment away from the space vehicle is desired to minimize interference and reflected signals from the vehicle structure (multipath propagation). Proven designs exist for the mechanical release and re-berthing mechanisms, and for the grapple fixture for use with the remote manipulator. This type of packaging and hardware design has been used already on early Shuttle missions with the Induced Environmental Contamination Monitor (IECM) which was deployed by the manipulator arm. The experiment container has an active closed-loop, thermal control system and includes batteries for operation of the maser clock during ground handling prior to launch. Otherwise, experiment power will be obtained from the utility Shuttle system. A minimum interface with the Space Shuttle systems makes the experiment compatible with a broader

range of complementary payloads and, thereby, increases flight opportunities.

Most Shuttle missions are flown in rather low earth orbits which allow for a short time interval between station contacts but give relatively short periods of visibility for individual ground stations. An orbital altitude of 360 km with  $57^\circ$  inclination has been assumed for the study. Figure 5 shows the ground tracks of the space vehicle and the radio horizon for some assumed locations of ground terminals. This pattern of orbital ground tracks is repeated every 24 hours. Time between over-flights and elevation angles for several stations is shown in Figure 6. Included are only those contacts in which the spacecraft remains visible from the ground for more than 6 minutes above 5 degrees elevation. The maximum time of visibility (contact with the spacecraft) above 5 degrees elevation is approximately 7 to 8 minutes. This visibility period is sufficient to perform time and frequency transfer. The above conditions, which are typical for a low-orbit Shuttle experiment, can be modified to some extent by selecting a Shuttle mission with different orbit parameters.

The accuracy capabilities of the STIFT system are such, that relativistic effects have to be taken into account. To correct for these effects requires accurate orbit data. The gravitational redshift effect depends on orbital altitude, and the relativistic Doppler effect (time dilatation) depends on the relative motion of the ground station and space vehicle. In the case of the Shuttle experiment, some special effort is needed to obtain orbit information of the required accuracy since Shuttle orbits are not as predictable as those of a free-flying satellite primarily because of space vehicle maneuvers executed during the mission. However, there are ways to overcome this difficulty.

In principle, accurate orbit data are needed only for those arcs during which the experiment operates during time and frequency transfer. Microwave two-way Doppler and range measurements made as part of the STIFT experiment can be used to improve orbit data available from the Mission Control Center. The laser ground stations also provide range measurements, accurate to a few centimeters and range rate measurements accurate to perhaps millimeters/second as well as angular position. These data, together with Shuttle operational navigation data, can be used with a standard orbit determination program to improve the accuracy of available orbit information. Another, and completely independent method, is the use of a Global Positioning System (GPS) receiver as part of the onboard experiment system. The GPS receiver can provide navigation data of required accuracy.

The number and locations of ground terminals for the Shuttle experiment is completely open at this time. To illustrate experiment operation during the Shuttle flight, a station configuration composed of two microwave terminals and two laser stations was assumed for analysis. Figure 7 shows two pairs of stations, each pair consisting of a microwave terminal and a laser station located close to each other to permit simultaneous operation of the microwave and laser systems. Each of the four stations is equipped with a hydrogen maser clock. The data output of the microwave terminals is the measured code shift  $\Delta t'$  and measured beat frequency  $\Delta f'$ . Relativistic corrections are applied to obtain the true difference in epochs,  $\Delta t$ , and the true frequency difference,  $\Delta f$ , between space clock and ground clock. These data are recorded on magnetic tape together with the telemetry housekeeping data from the onboard and ground systems. The relativistic corrections to be applied to the time and frequency differences are computed from orbit information generated by the orbit update program which receives a variety of inputs, including coarse orbit data from the Mission Control Center in Houston and range and range rate measurements from the microwave terminal and the laser station. The laser station can also provide direction cosine information. Other tracking data could be obtained including tracking data from mobile laser stations, onboard Shuttle navigation data received by telemetry, and navigation data from an experimental GPS receiver included in the STIFT onboard system.

The laser station will be equipped with an S-band telemetry receiver to obtain the onboard measurement of the laser pulse arrival time  $T_2$  which is required to determine the epoch difference  $T$ . Again relativistic corrections are applied to obtain the true difference in the epochs. Predicted pointing information for the laser telescope is derived from the orbit data received from the Mission Control Center. If an onboard GPS receiver is used, orbit determination and relativistic corrections could be accomplished in the Shuttle, and the resulting information could be distributed to ground stations by telemetry.

The same considerations apply to the remote station pair. All ground stations/terminals will be connected by data and voice link to the Mission Control Center for scheduling of station operations and distribution of operational information. In addition, the data links between ground stations/terminals can be used to exchange processed data of time and frequency transfer for evaluation of experiment performance during the Shuttle mission.

## System Performance

There are two aspects concerning the accuracy of time and frequency transfer, namely the transfer between space clock and ground clock and the transfer between clocks on the ground using the space clock as a transfer standard.

In the Shuttle experiment the following accuracies can be expected for the space-to-ground transfer during a typical contact with a ground station: Microwave frequency transfer  $\Delta f/f=10^{-14}$ , microwave time transfer  $\Delta t=1$  nanosecond or better and laser time transfer  $\Delta t=0.1$  nanosecond. These accuracy goals are based on the results obtained from earlier experiments (GP-A and aircraft laser experiments). Advances in technology in recent years should make it possible to achieve further improvements in accuracy for the Shuttle experiment.

Figure 8 shows the recent improvements in clock performance. In the 1976 Redshift Test the microwave system demonstrated stability performance at the  $10^{-14}$  level for 100 second averaging; this was the limit set by the then available hydrogen maser. The STIFT clock will benefit from advancements in maser technology which are reflected by the stability curve for the 1979 hydrogen maser. It is, therefore, reasonable to assume that the accuracy of the STIFT system will approach the several parts in  $10^{15}$  level for the 4 to 5 minutes of observing (averaging) time available during typical ground station contacts.

Figure 8 also shows why the hydrogen maser is the obvious choice for the STIFT flight clock. It provides the highest degree of stability not only for the station contact intervals, but also for time intervals between station contacts (typically up to a few hours; see Figure 6).

A particularly important finding of the previous microwave and laser experiments was that the transfer systems did not introduce detectable errors into the time and frequency transfers. Since the Shuttle experiment represents a substantially different type of operation it is appropriate to examine its limits. Two relativistic effects, the gravitational redshift and the relativistic (second order) Doppler effect cause a shift in the frequency of the space clock oscillator as measured on the ground. The resulting effect in the frequency transfer and in the time keeping between the flight clock and ground stations must be accounted for. These relativistic effects are removed from the comparison data by analytical means using tracking data.

For the frequency transfer the present goal is to account for relativistic effects within a fractional frequency error of  $1 \times 10^{-15}$ . This requires accuracies of 10 meters in orbital altitude and about 1 centimeter per second in relative velocity.

Updating orbital data, as outlined earlier, should provide the necessary accuracy in orbit parameters for the short orbital arcs of experiment operation.

To assess the influence of relativistic effects on time transfer between stations one has to consider orbit prediction for periods between station contacts. For a circular orbit both relativistic effects depend only on spacecraft altitude as shown by the following expression:

$$\frac{\Delta T}{T} \approx \frac{GM}{2C^2 R_e} \left[ 1 - \frac{3h}{R_e} \right]$$

and

$$\delta \left( \frac{\Delta T}{T} \right) \approx \frac{3GM}{2C^2 R_e^2} \delta h$$

where

h is the altitude

$R_e$  is the radius of the earth

From this one obtains  $\delta \left( \frac{\Delta T}{T} \right) = 5.9 \times 10^{-4} \left( \frac{\text{ns}}{\text{hour}} \right) / \text{meter}$ .

Therefore, if station-to-station contacts are arranged to be separated by only a few hours (see Figure 6), fairly large intra-station errors in altitude can be tolerated. For time transfer contacts separated by intervals of the order of 1 orbital period (90 minutes) even a kilometer error in the spacecraft altitude would impart only about a nanosecond error.

Differential phase changes between the individual microwave carrier links are a potential error source in the RF system. The Doppler cancellation system eliminates phase perturbations that apply uniformly to all three microwave links. In designing the RF system special attention must be given to minimize differential phase changes in those parts of the system, where the carrier signal paths are separated, by selecting components and units which have a low phase/temperature coefficient. The necessary phase stability can be achieved by providing temperature control for critical subsystems as was demonstrated with the GP-A system. For example, the GP-A flight transponder exhibited a phase/temperature coefficient of 13 degrees/°C, which was compensated for by temperature control. If the same transponder were used for STIFT, temperature control of 0.25°C/hour would reduce its error contribution in the frequency transfer to the part in  $10^{15}$  level. This temperature stability is well within the state-of-the-art. In addition, it is always possible to calibrate the phase versus temperature behavior and to apply appropriate corrections derived from telemetry data.

Another potential source of phase perturbations is the flight antenna. Even though all three carrier signals use the same antenna, care must be taken to provide approximately equal phase characteristic for all three frequencies over a large



portion of the antenna pattern to minimize differential phase changes in the RF loops as the aspect angle between ground terminal and spacecraft changes during a contact.

The first order atmospheric and ionospheric refraction effects are eliminated by the Doppler cancellation system. The former because atmospheric refraction enters all three links uniformly and the latter because of the careful selection of frequencies used in the transfer (see Figure 2). The exact frequency selection for the ionospheric cancellation is based on the very good approximation that at S-band frequencies the ionosphere behaves like a dispersive medium whose refractive index is inversely proportional to the square of the frequency. With this approximation it is possible to start with the maser signal in Figure 2 and follow the frequency multiplication paths to show that if the relation

$$\left[ \frac{\text{Ground Maser Uplink Frequency}}{\text{Flight Maser Downlink Frequency}} \right]^2 = \frac{1}{2} \left[ 1 + \frac{1}{(\text{Transponder Factor})^2} \right]$$

is satisfied, then ionospheric effects cancel.

Otherwise, only rare propagation anomalies may affect the operation of the experiment. There are occasions when ionospheric or atmospheric conditions can limit the experiment, particularly for operations attempted at very low elevation angles. In this study an operational limit of five degrees above the horizon has been used for planning purposes. Anomalous atmospheric refraction or unusual ionospheric scattering could drive the limit higher on occasion. In general these effects will impose no limit at all and the experiment can be operated essentially to the line-of-the sight cut-off. The foregoing discussions on performance deal specifically with a Shuttle demonstration experiment and somewhat different considerations apply to an operational STIFT system. For example, a more predictable, higher altitude orbit would be selected for such a system. Overall, the performance of an optimized operational system should be better than what can be achieved with the Shuttle experiment.

### Conclusions

With continuing advancements in the performance of time and frequency standards the need for a higher accuracy global clock comparison system ever increases. The needs within the navigation, communication, and electric power technologies also continue to push for higher and higher synchronization accuracies among remote clocks. Figure 9 shows the improvements in the accuracy of NBS laboratory frequency standards over time together with the performance of clock comparison methods. Clock accuracy increased by a factor of 10 approximately every 7

years since 1950 (8), (9), (10). There are reliable indications that this trend will continue in the future, at least at the same rate, as shown by the projected accuracy of an improved cesium standard and a mercury standard using laser cooled ion storage techniques. Historically the accuracy of long distance (international) clock comparison methods, as measured over 24 hours, has always been lower than the accuracy of existing standards and this situation persists today with GPS currently being the most accurate generally available method. The proposed STIFT concept represents a major step in performance improvement and is the most accurate method for global time and frequency transfer conceived so far. The system would be able to satisfy growing accuracy needs of the future.

### References

- (1) Allan, D.W., C.O. Alley, Jr., R. Decher, R.F.C. Vessot, and G.M.R. Winkler, "Shuttle Experiment to Demonstrate High-Accuracy Global Time and Frequency Transfer," IEEE Trans. Geo. and Remote Sensing, GE-20, 3, 321-325, 1982.
- (2) Vessot, R.F.C., M.W. Levine, E.M. Mattison, E. L. Blomberg, T. E. Hoffman, G. V. Nystrom, B.F. Farrel, R. Decher, P. B. Eby, C. R. Baugher, J. W. Watts, D. L. Teuber, and F. D. Wills, "Test of Relativistic Gravitation with a Space-borne Hydrogen Maser," Phys. Rev. Lett., 45, 2081, 1980.
- (3) Vessot, R.F.C. and M. W. Levine, "A Test of the Equivalence Principle Using a Spaceborne Clock," General Relativity and Gravitation, 10, 181-204, 1979.
- (4) Alley, C.O., "Relativity and Clocks," in Proc. 33rd Annual Frequency Control Symposium. (Atlantic City, NJ) pp.4-39, May 1979.
- (5) Penfield, H., E. Imbier, and R.F.C. Vessot, "Design of the STIFT Time and Frequency Microwave Ground Terminal," in Proc. 14th Annual PTTI Planning Meeting (NASA Goddard Space Flight Center, Greenbelt, Md., November 30-December 2, 1982) (in press).
- (6) Alley, C.O., J. D. Ragner, C.L. Steggerda, J.V. Mullendore, L. Small, and S. Wagner, "Time Transfer Between the Goddard Optical Research Facility and the U.S. Naval Observatory using 100 picosecond Laser Pulses," in Proc. 14th Annual PTTI Planning Meeting (NASA Goddard Space Flight Center, Greenbelt, Md., November 30-December 2, 1982) (in press).
- (7) Vessot, R.F.C., "Relativity Experiments with Clocks," Radio Science, 14, No. 4, pp. 629-647, 1979.

- (8) H. Lyons, Ann. N.Y. Academy of Science, No. 55, 831, 1952, Ann. Sci. America 196, 71, Feb. 1957.
- (9) Atomic Clock and Atomic Standard of Frequency and Time, NBS Technical News Bulletin, Vol. 33, No. 2, pp 17-24, February 1949.
- (10) Beehler, R. E., Cesium Atomic Beam Frequency Standard: A survey of laboratory standards developed from 1949-1971, Proc. 25th Annual Symposium on Frequency Control, p. 297, 1971.
- (11) Beehler, R. E., A Historical Review of Atomic Frequency Standards, Proc. IEEE, 55, p. 792, 1967.
- (12) Beehler, R. E., R. C. Mockler, and J. M. Richardson, Metrologia, 1, p. 114, 1965.
- (13) Glaze, D. J., Helmut Hellwig, Steve Jarvis, Jr., A. E. Wainwright, and D. W. Allan, Recent Progress on the NBS Primary Frequency Standard, Proc. 27th Annual Symposium on Frequency Control, p. 334, 1973.

STIFT CONCEPT

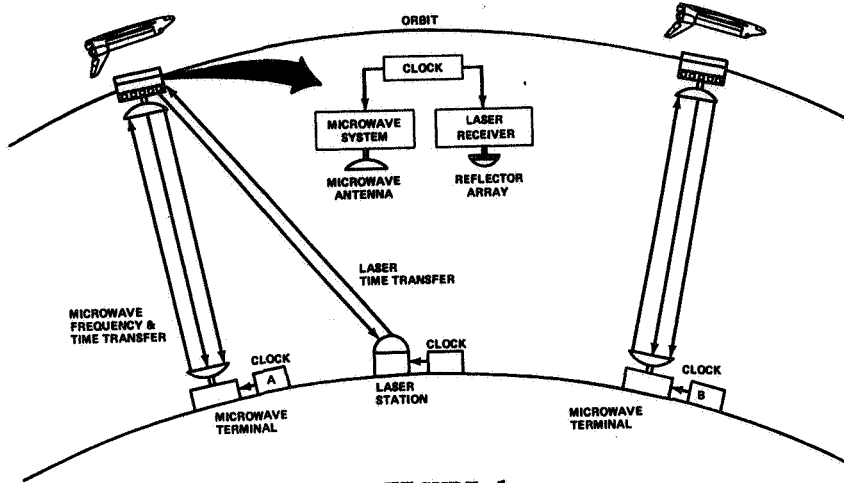

FIGURE 1

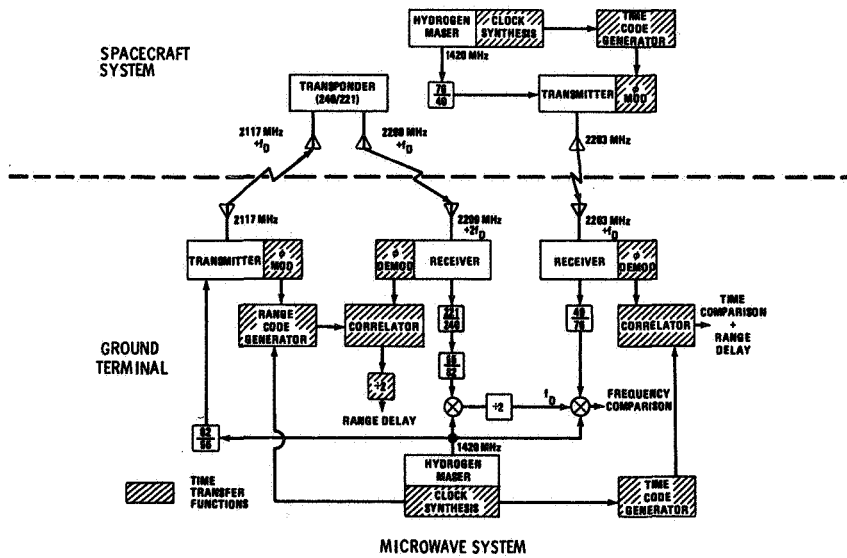
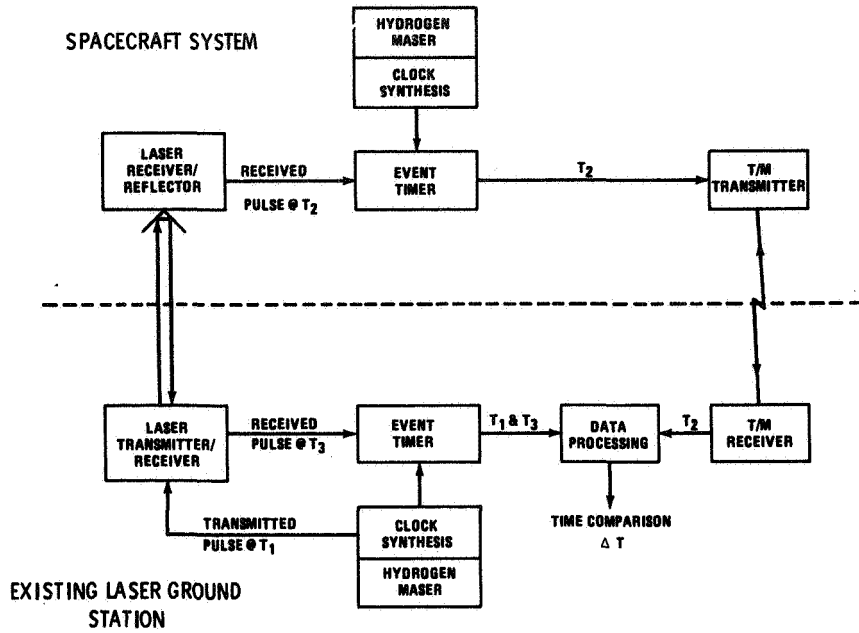

FIGURE 2



Laser Transfer System

FIGURE 3

STIFT EXPERIMENT  
(SHUTTLE TIME AND FREQUENCY TRANSFER)

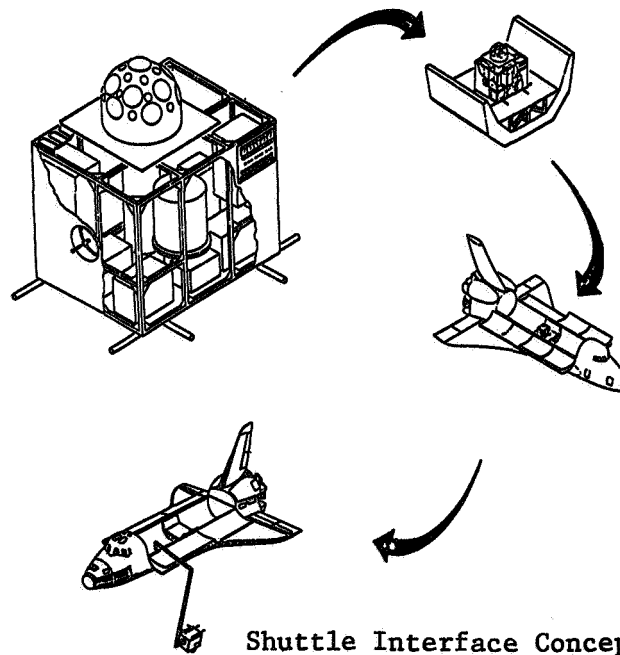

Shuttle Interface Concept

FIGURE 4

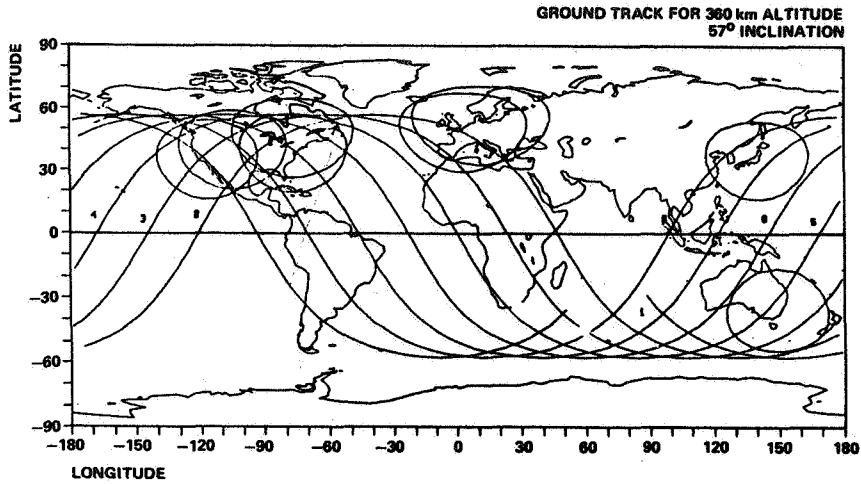

**POTENTIAL LOCATION FOR MICROWAVE GROUND TERMINALS**

<u>DSN</u>	<u>NATIONAL STANDARD LABS.</u>	<u>TIME SERVICES</u>
GOLDSTONE	NBS - U. S.	USNO - U. S.
MADRID	NRC - CANADA	BIH - FRANCE
CANBERRA	PTB - W. GERMANY	
	RRL - JAPAN	

FIGURE 5

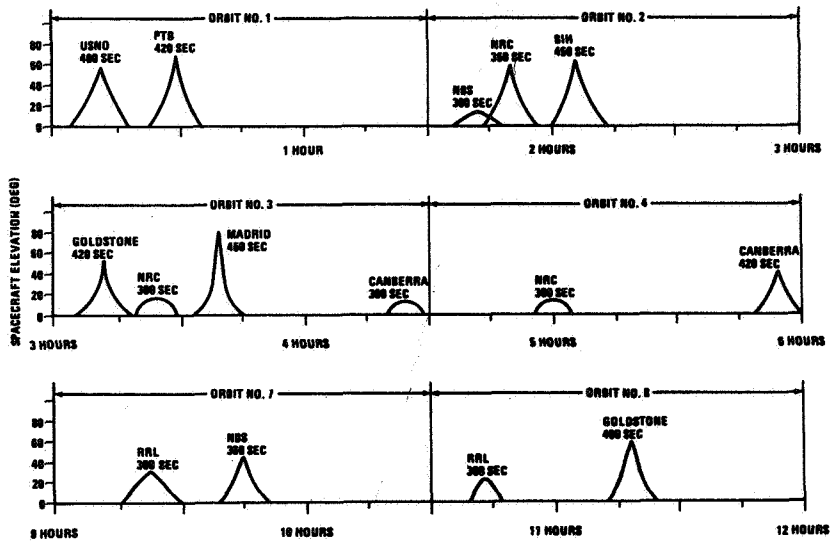

**STIFT Elevation at Ground Stations**

FIGURE 6

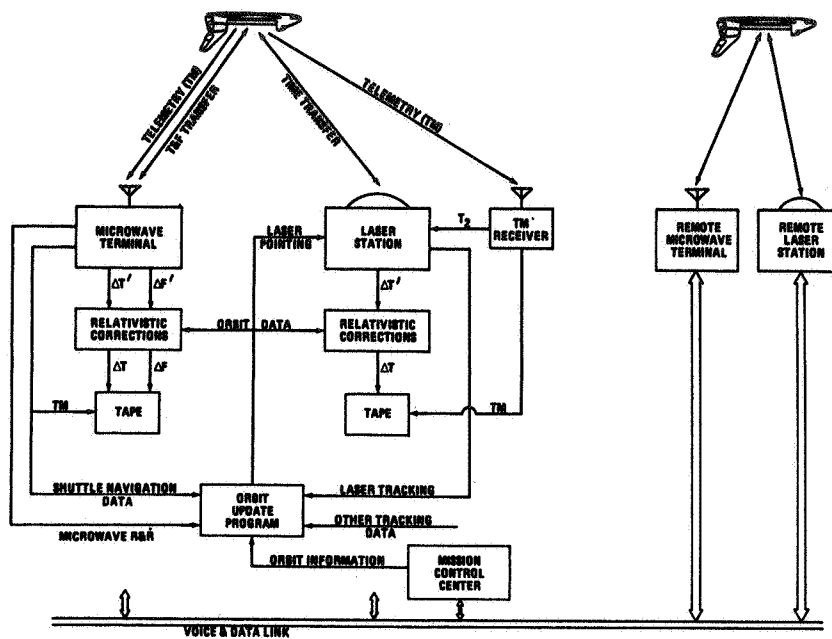

Data System and Interstation Communications

FIGURE 7

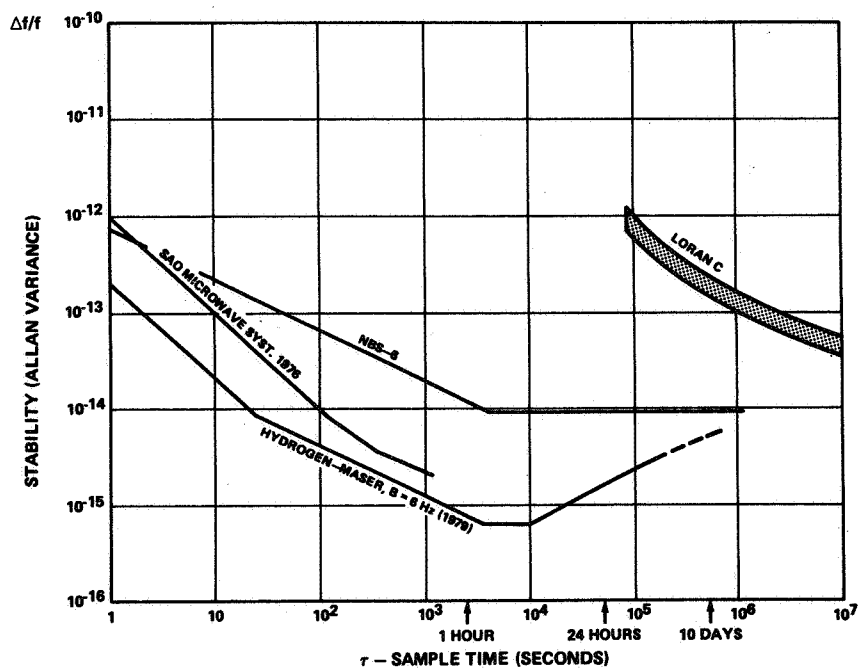

Advances in Start-of-the-art Masers

FIGURE 8

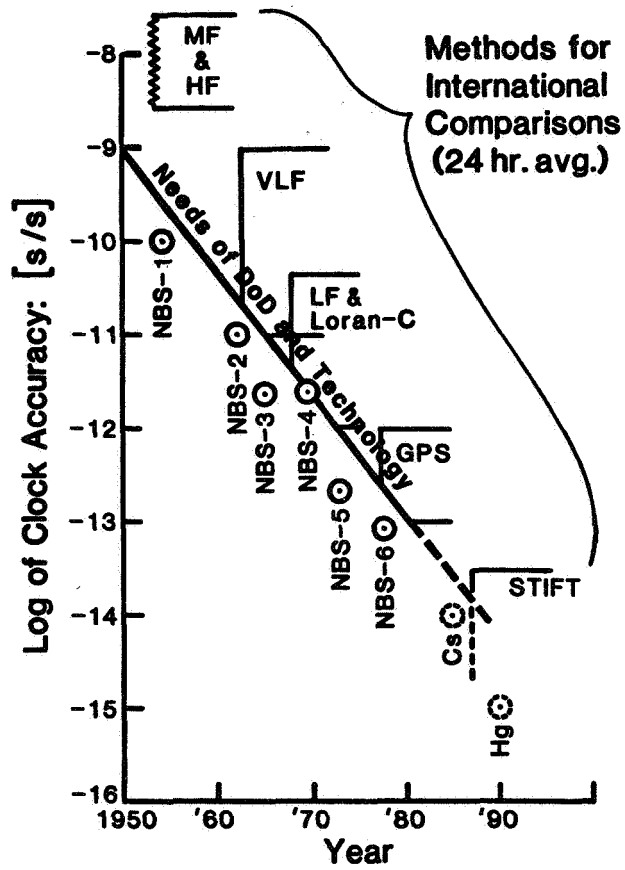

Historical Progress in Clock Accuracy Requirements

FIGURE 9



QUESTIONS AND ANSWERS

None for Paper #10.