

## CESIUM STANDARD FOR SATELLITE APPLICATION

M. Bloch, M. Meirs, I. Pascaru, B. Weinstein  
Frequency Electronics, Inc., Mitchel Field, New York

### ABSTRACT

This paper discusses a Cesium Frequency Standard that has been developed for satellite applications. It weighs 23 lbs. and uses 23.5 watts of power, achieves a stability of  $1 \times 10^{-13}/10^5$  seconds, and is radiation hardened to meet GPS Phase II requirements. To achieve the weight and reliability requirements, both thick and thin film hybrid circuits were utilized. An SC-Cut crystal oscillator is used to improve short-term stability and performance on a moving platform.

### INTRODUCTION

In order to meet GPS performances and weight requirements the Portable Real Time Clock [1] presently manufactured by Frequency Electronics, Inc. was redesigned. Hybrids were utilized for critical modules to increase the reliability and to lower the weight. A new air "C" field was used in the cesium resonator, in order to improve the frequency stability of the standard as a function of temperature. Radiation and thermal-vacuum operation were the prime factors in the mechanical design of this standard.

The chassis of the Standard is machined from a solid piece of aluminum to form a "shoe box" on which all the modules are mounted. A modular approach was taken to allow each subassembly to be individually tested to its performance requirements prior to integration in the system. A photograph of the Standard is shown in Figure 1. This shows the outside of the shoe box with the A6 Power Supply located on the extreme right-hand side. Adjacent to the power supply is the A4 high precision SC-cut oscillator. On the extreme left-hand side is an RF filter box through which all of the power and telemetry interface signals are filtered before entering the Cesium Standard. Also located under this cover are the two high voltage power supplies (A2 and A3) for the Vac Ion and Electron Multiplier, respectively. The Vac Ion Pump is also located under this enclosure.

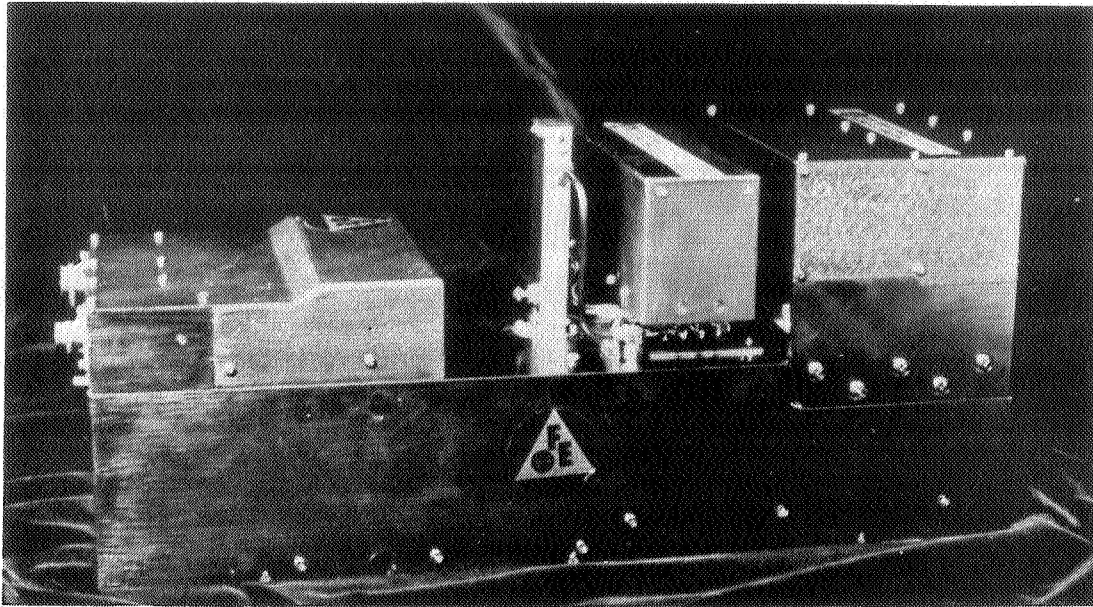

Figure 1 Portable Real Time Clock

Figure 2 is a photograph of the underside of the shoe box. The Cesium Beam Tube, A1, is located in the center of this area. The telemetry interface module, A8, is located directly above the tube. Below the tube are the A5 Modulator/Multiplier and A7 Synthesizer modules.

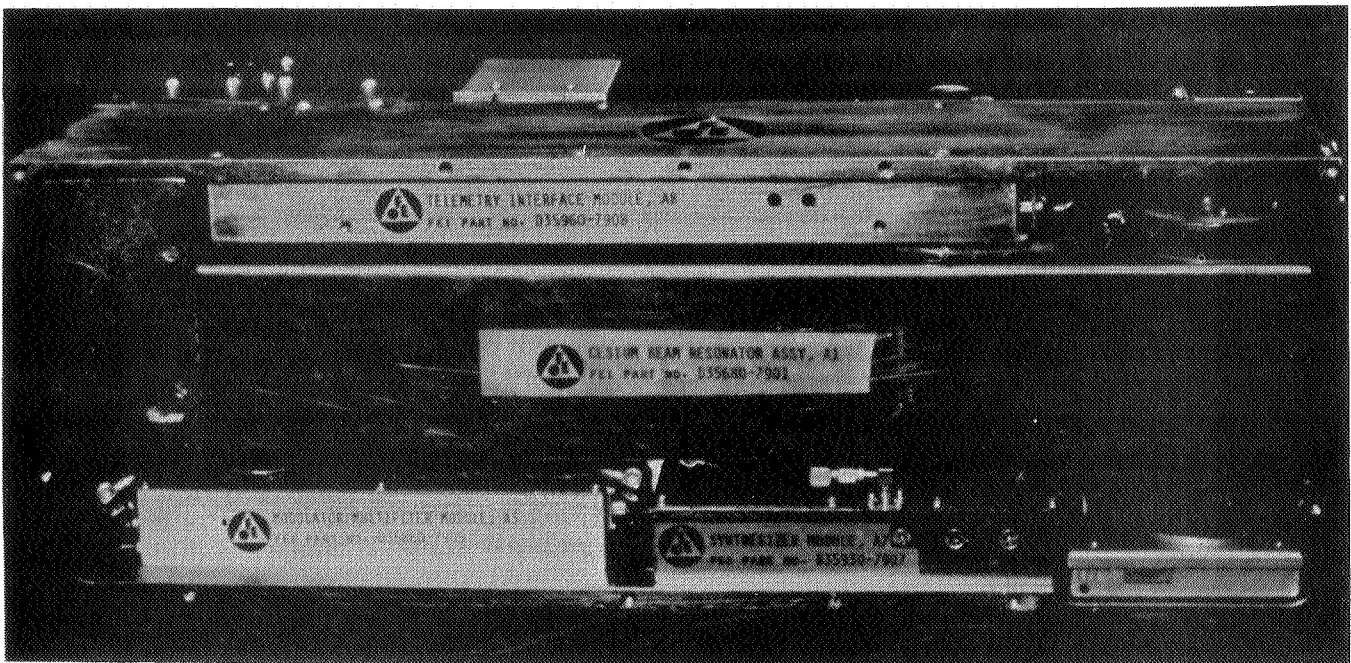

Figure 2 Portable Real Time Clock, Bottom View

## SYSTEM DESCRIPTION

Figure 3 is a block diagram of the Cesium Standard. The 10.23 MHz output is taken from the A4 Oscillator Module. The 5.115 MHz oscillator frequency is split and drives the A5 Multiplier/Modulator and A7 Synthesizer. The multiplier/modulator phase modulates this frequency at an 83 Hz rate and then multiplies the signal by 1800 where it is mixed with a Synthesized 14.368 MHz beat frequency. This generates the 9.192+ GHz Cesium Transition Frequency which is fed into Cesium Beam Tube A1. Telemetry Interface Module A8 accepts discrete commands to direct the Cesium Standard and provides analog and digital monitors on the status of the Standard. Power supply A6 is the main DC to DC Converter that uses the 26.5 Vdc input to generate the necessary system voltages. Assemblies A2 and A3 are the High Voltage Power Supplies for the Vac Ion Pump and Electron Multiplier, respectively. These power supplies have been designed to be short-circuit-proof and to withstand the pressure environments from air to vacuum.

Figures 4 and 5 are photographs of the top and bottom of Multiplier/Modulator Module A5.

## PERFORMANCE RESULTS

Tests have been performed on the prototype unit of the Spacecraft Cesium Clock, (SCC) with the following results. The Allan Variance was measured out to  $10^5$  seconds and showed a noise floor of  $1 \times 10^{-13}$ . This graph is shown in Figure 6. A phase deviation plot for a period of 4.63 days is shown in Figure 7. A summary of the specification requirements vs. the measured results is shown in Table 1. A thermal analysis was made on the SCC to determine the maximum temperature rise which will be seen in the vacuum environment. Figure 8 shows the location of the modules and test points. Figure 9 is the thermal equivalent circuit of the SCC from each module to the mounting plate. A maximum base plate temperature of  $45^\circ\text{C}$  was used. Table 2 summarizes the calculated temperatures with two of the actual measurement points that were made in thermal vacuum measurements. Relatively good correlation was obtained, especially when considering that the analysis used worst case conditions.

## CONCLUSIONS

A Spacecraft Cesium Clock has been successfully designed and built that is capable of meeting the GPS Phase II requirements. As of this date, thermal analysis, thermal test and radiation testing have been completed with excellent results. Flight units are in fabrication and will be completed in mid 1983.

318

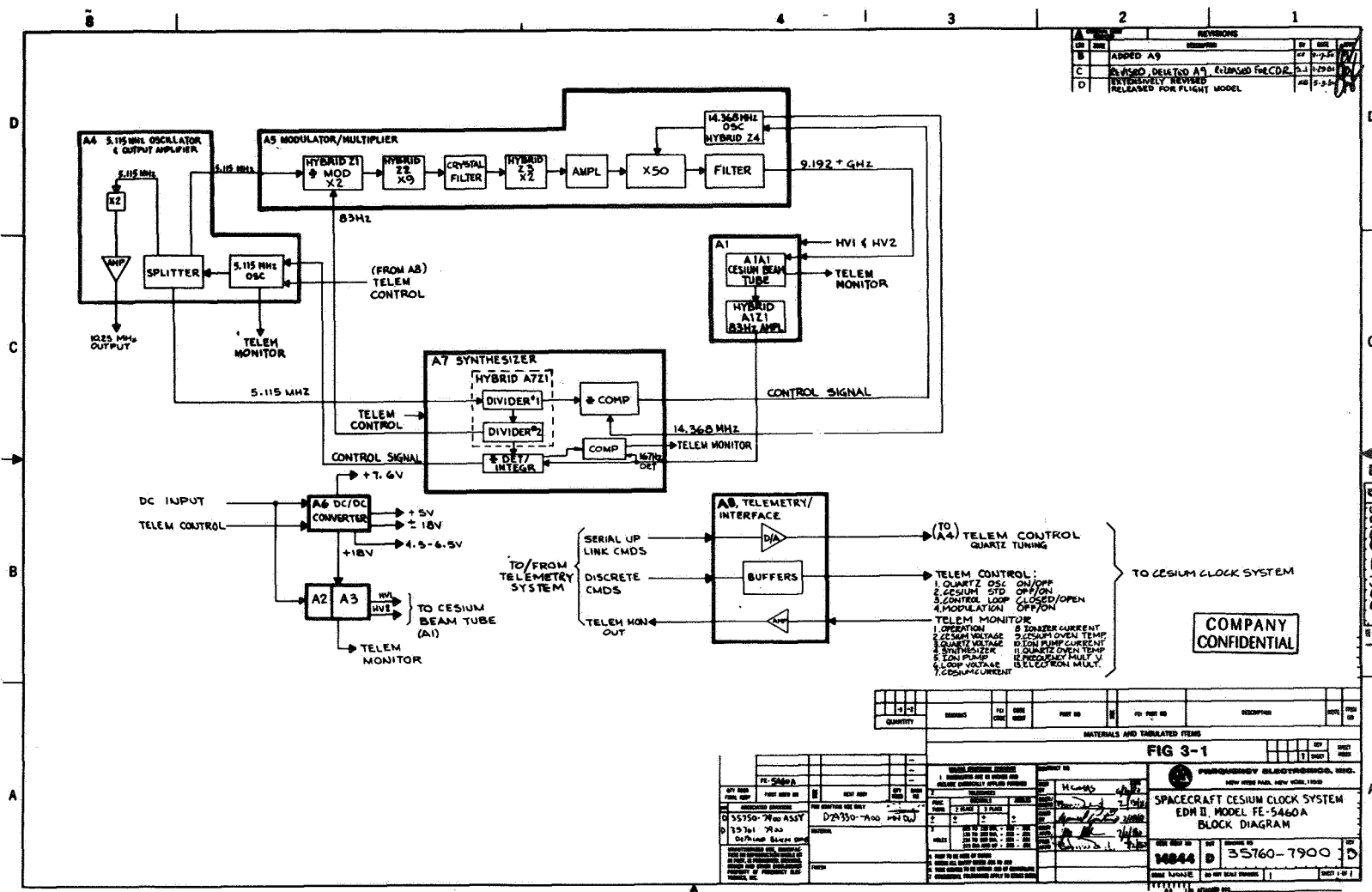

Figure 3 Spacecraft Cesium Clock System EDM II, Model FF-5460, Block Diagram

HYBRID 2X MULTIPLIER 5-10 MHZ    HYBRID 9X MULTIPLIER 10-90 MHZ

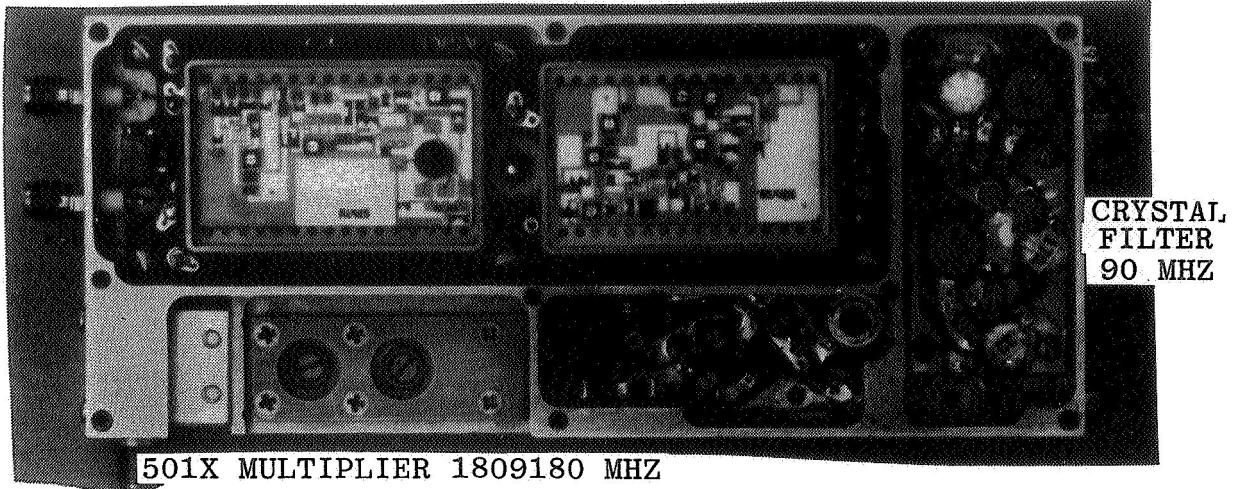

Figure 4 Modulator/Multiplier Module, A5

HYBRID OSCILLATOR 14 HZ    DC FILTER/REGULATOR

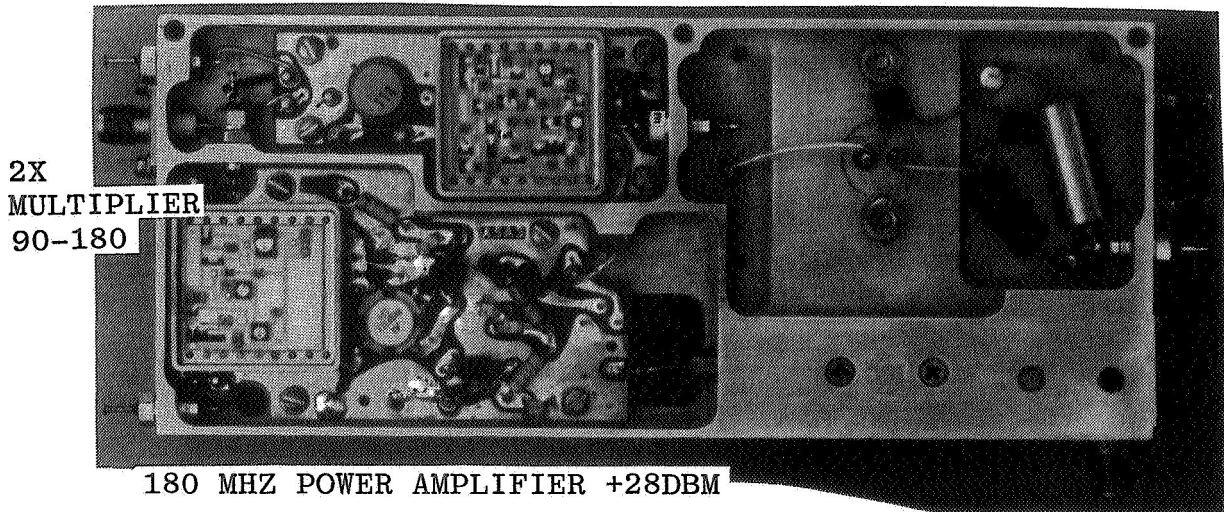
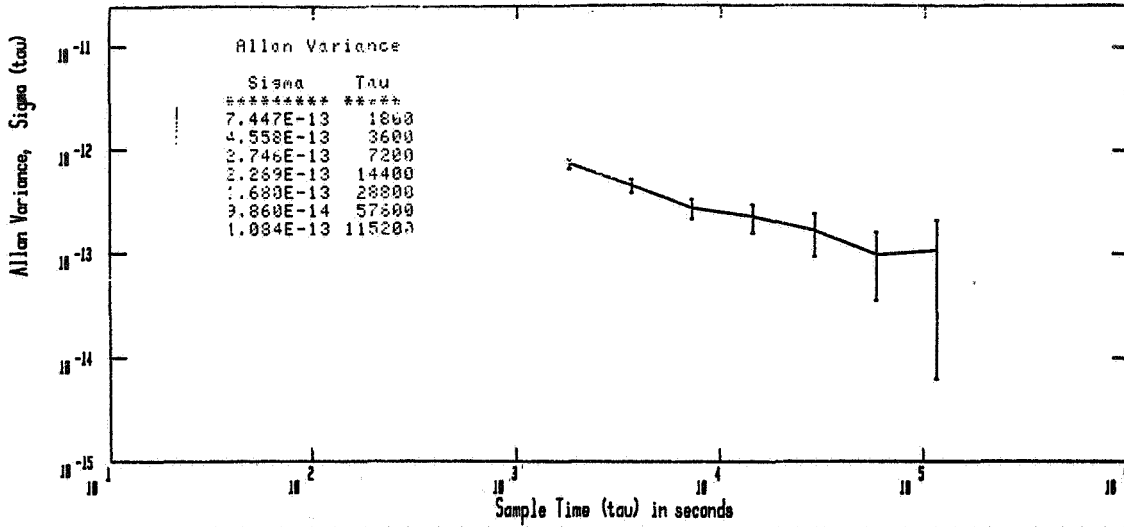

Figure 5 Modulator/Multiplier Module, A5



Date	Program	Data File Name	Points Found	Frequency	Measurement Interval	Counter Gate Time
10-05-82	Allan Variance	FE11	326	10.23 MHz	1800 secs	100 msec

Figure 6 Allan Variance, Spacecraft Cesium Clock, (SCC) FE-5460A

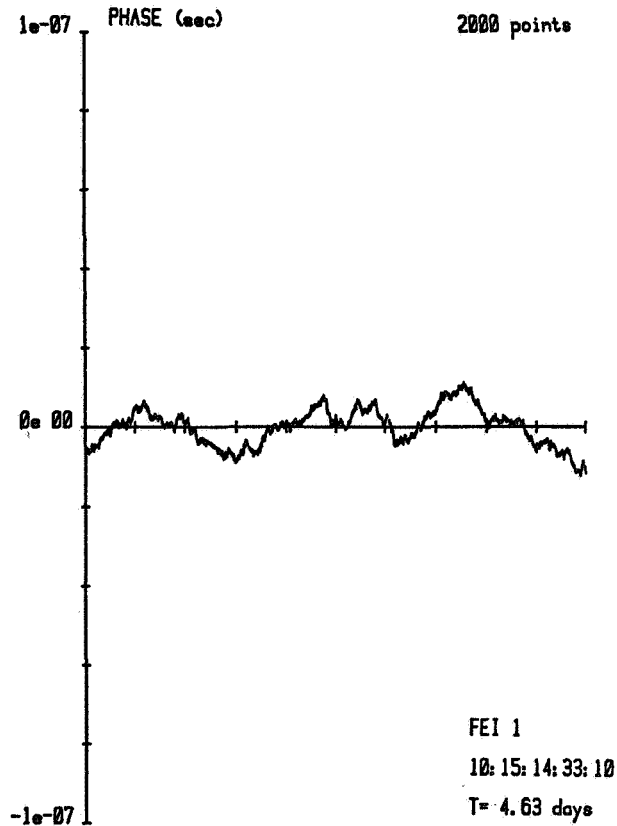

Figure 7 Phase Deviation, Spacecraft Cesium Clock(SCC) FE-5460A

TABLE I REQUIREMENTS VS. PERFORMANCE

PARAMETER	TECHNICAL REQUIREMENTS	MEASURED RESULTS PROTOTYPE
ACCURACY	$\leq \pm 1 \times 10^{-11}$	$\pm 5 \times 10^{-12}$
TEMPERATURE COEFFICIENT	$< 5 \times 10^{-14}/^{\circ}\text{C}$ goal of $\pm 1 \times 10^{-14}/^{\circ}\text{C}$	$8 \times 10^{-14}/^{\circ}\text{C}$ ( $1.2 \times 10^{-14}/^{\circ}\text{C}$ on breadboard)
POWER		
WARM UP	$\leq 50\text{W}$	34.4W
OPERATING	$\leq 30\text{W}$	23.5W
WEIGHT	$\leq 28 \text{ lbs}$	23 lbs
WARM UP TIME (Lock)	60 min	<35 min

TABLE II SPACECRAFT CESIUM CLOCK  
THERMAL ANALYSIS

MODULE	T(°C) CALCULATED	T(°C) MEASURED IN VACUUM
A1A7	58.7	
A1AB	58.7	
A1B	56.2	
A2	51.8	
A3	51.4	48.5
A4A	59.4	
A4B	59.4	
A5	56.4	
A6A	61.7	55.6
A6B	61.7	
A7	53.1	
A8	51.6	

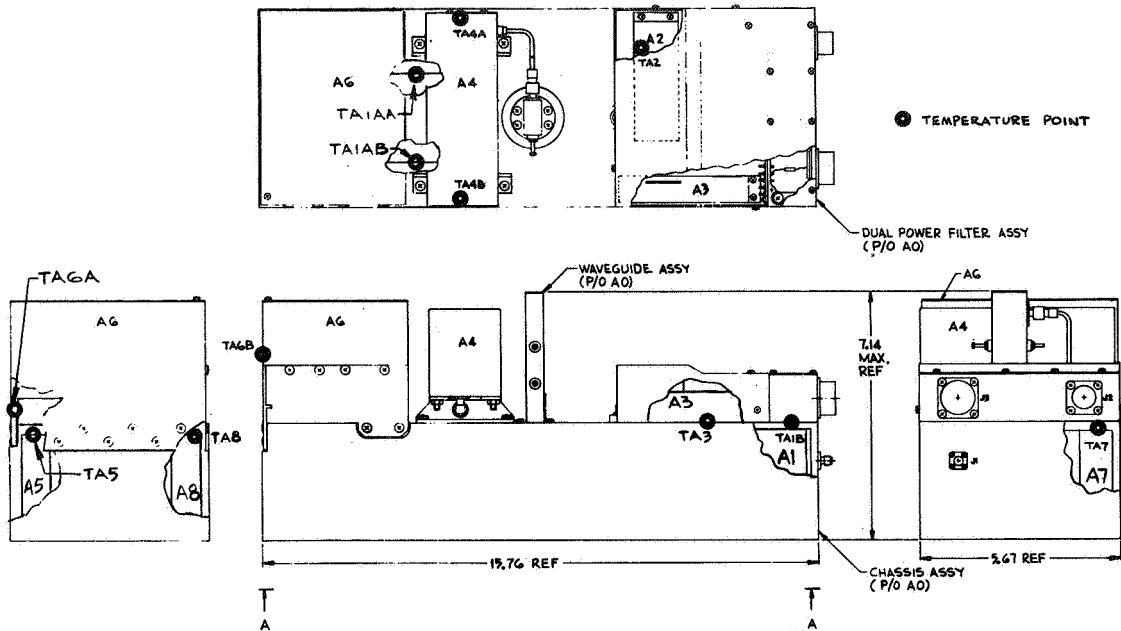

Figure 8 Thermal Measurements, Spacecraft Cesium Clock A6 Deck Mounted, Final Configuration

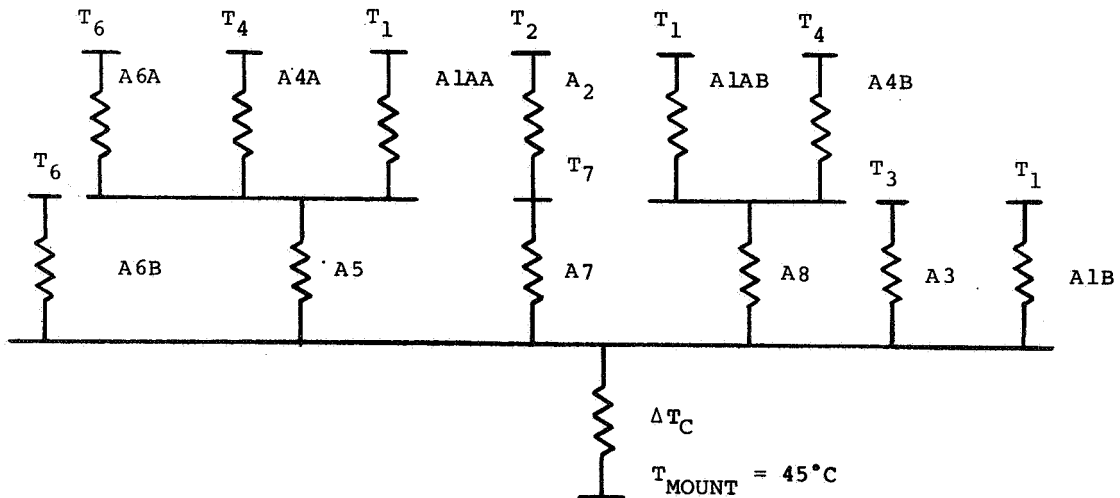

Figure 9 Thermal Schematic of Final Configuration