

TEST RESULTS OF THE STI GPS TIME TRANSFER RECEIVER*

David L. Hall, Jim Handlan** (HRB-Singer) and
Paul Wheeler (U.S. Naval Observatory)

ABSTRACT

Global time transfer, or synchronization, between a user clock and USNO UTC time can be performed using the Global Positioning System (GPS), and commercially available time transfer receivers. This paper presents the test results of time transfer using the GPS system and a Stanford Telecommunications, Inc. (STI) Time Transfer System (TTS) Model 502. Tests at the GPS Master Control Site (MCS) in Vandenburg, California and at the United States Naval Observatory (USNO) in Washington, D.C. are described. An overview of GPS, and the STI TTS 502 is presented. A discussion of the time transfer process and test concepts is included.

INTRODUCTION

This paper describes test results using the Stanford Telecommunications Inc. (STI) Time Transfer System (TTS) Model 502 to perform time transfer between a user clock and Universal Time Coordinated (UTC) available from the United States Naval Observatory (USNO). The time transfer procedure makes use of the STI TTS 502 receiver and the Global Positioning System (GPS) to synchronize a user's clock to UTC in a two step procedure:

- 1) time transfer between the user's clock and the GPS Master Clock (located at Vandenburg, California) using observations of GPS satellites,
and
- 2) transformation between the GPS Master Clock and UTC time based on USNO synchronization data.

A brief description of the GPS system is provided along with a discussion of the time transfer procedure used at the USNO to synchronize UTC and GPS MCS time. More detail is available in the literature (References (1) and (2), respectively). A description of the time transfer procedure using the

* This work was sponsored by the United States Government. The views and conclusions contained in this document are those of the authors and should not be interpreted as necessarily representing the official policies, either expressed or implied, of the United States Government.

** Current Address - Susquehanna University, Pennsylvania

STI TTS 502 receiver, is also presented.

Test results are described which indicate the absolute accuracy of time transfer using the STI TTS 502. These results are based on tests performed at the GPS MCS. Further test results at the USNO establish the baseline accuracy with which time transfer can be performed between a user clock and UTC.

BACKGROUND

The GPS system and commercially available receiver systems, provide the capability for a user to determine his global position, velocity and time with a high degree of accuracy. As originally planned, the GPS was to consist of a space segment of twenty-four satellites and a ground segment of a Master Control Site (MCS) and five or more Monitor Sites (MS), one of which was to be located at the USNO. The monitor sites function is to receive transmissions from each GPS satellite, referred to a local clock, and to retransmit this information to the MCS over secure data communications links. The MCS correlates this information with other data, performs the necessary calculations to determine current satellite performance parameters and uplinks this information to each GPS satellite on a daily or, as required, basis. The uplinked data provides current information on clock performance and navigation data. The satellites were intended to be equally distributed in three orbital planes inclined to the Earth's equatorial plane by 63 degrees with the ascending nodes of the orbital planes differing by 120 degree intervals.

Funding cutbacks have reduced the planned number of satellites to eighteen. This cutback will affect position/velocity determination, but have little effect on time transfer, since only one satellite needs to be visible to a user to perform time synchronization.

GPS SATELLITE SIGNAL

Reference (3) describes the GPS data transmission process and structure. Briefly, data are transmitted from the GPS satellites on two carrier frequencies, a primary, L_1 , at 1575.42 MHz and a secondary, L_2 at 1227.6 MHz. The L_1 frequency is simultaneously modulated by a precision (P) code and a coarse/acquisition (C/A) code. The L_2 frequency is modulated by either a P or C/A code. Every six seconds a 50 bps message stream is transmitted with a total frame size of 1500 bits, common to both frequency bands and to both P and C/A codes. Each frame is divided into five 300 bit subframes which are further subdivided into ten 30-bit words. Telemetry and code handover information is contained in the first two words of each subframe. Key to the time transfer process is data contained in the first three subframes. The last eight words of Subframe 1 contain clock corrections consisting of second order polynomial coefficients which represent the variation

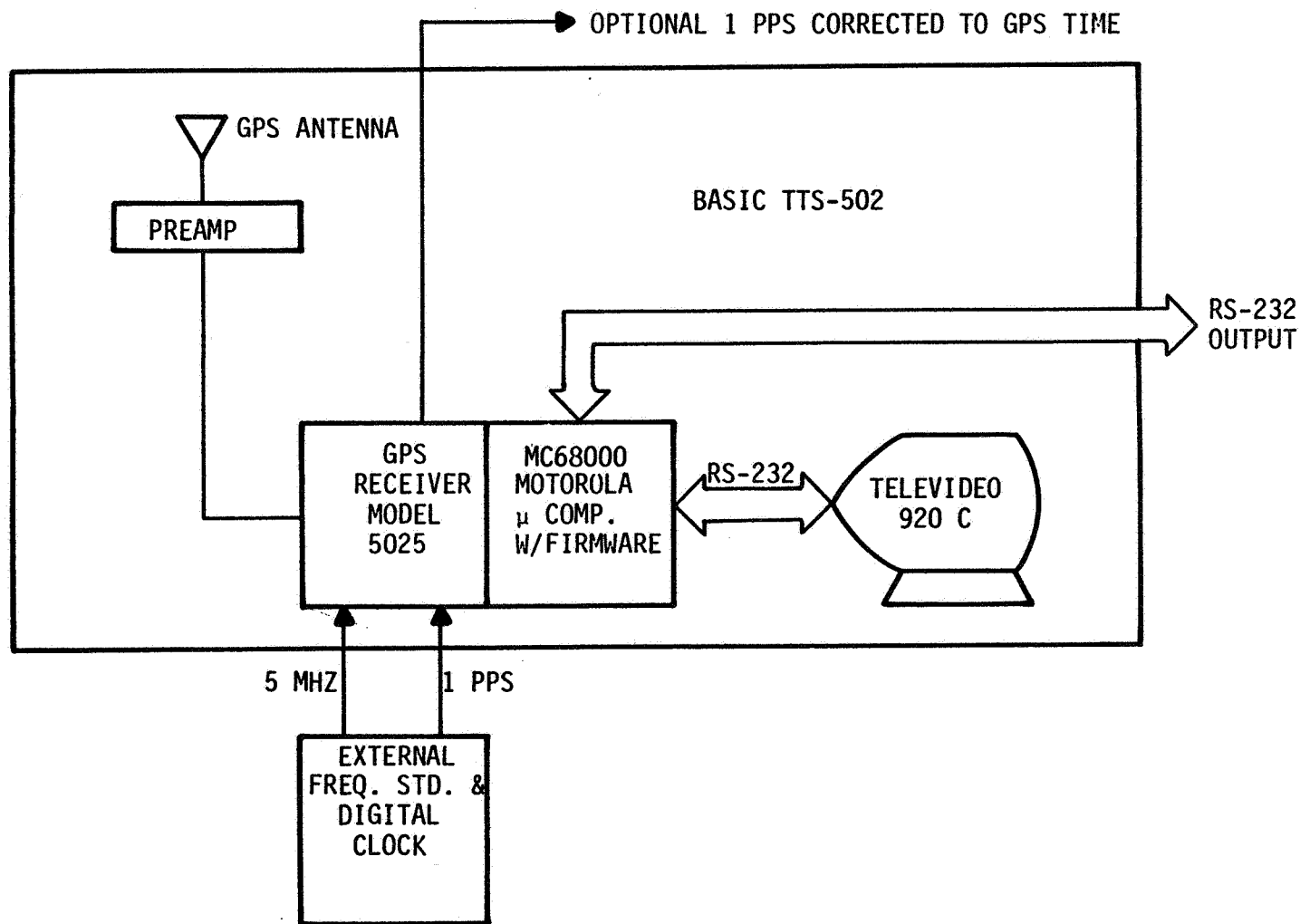

FIG. 1 SCHEMATIC OF TTS-502 SYSTEM

of the GPS satellite onboard clock with respect to the GPS master clock. Also included is an age of data word, and ionospheric delay model parameters. The GPS satellites ephemeris and age of data words are contained in Subframes 2 and 3. Subframe 4 provides an alphanumeric message for GPS users while Subframe 5 contains an Almanac (reduced accuracy version of information in Subframes 2 and 3) for each of the other GPS satellites in the constellation. Subframe 5 contains data on a single GPS satellite so that a sequence of frames is required to specify the Almanac for the complete GPS constellation.

The time transfer process using GPS requires that a user be capable of receiving, demodulating and decoding the transmitted data stream from a visible GPS satellite. The observed GPS satellite transmits the onboard satellite clock time (and corrections to the GPS master clock), which allows the user to compare the "observed" GPS time with time from his own clock. Corrections for propagation delays are required including free space instantaneous distance from GPS satellite to user, tropospheric/ionospheric delays, and equipment delays. Applying these corrections allows a measurement of the difference between the GPS master clock and the user's clock. The STI TTS Model 502 performs such a measurement for a user at a known location.

STI TIME TRANSFER SYSTEM

The STI Time Transfer System is shown schematically in Figure (1) and described in detail in Reference (4). The system consists of a GPS antenna, a preamplifier, time transfer receiver/processor and alphanumeric terminal for control of the receiver/processor. An external user clock (e.g., Cesium Beam Standard) is connected to the TTS 502 including a 5 MHz and 1 pps input. Firmware in the Motorola microprocessor provides several functions, including the following.

- 1) Scheduling the receiver to observe user selected GPS satellites. An automatic update option allows a user to specify an initial observation schedule. The microprocessor then uses the GPS ephemeris data to compute look angles accounting for orbit precession.
- 2) Perform raw time transfer observations every six seconds as scheduled, including;
 - a) derive satellite transmission time,
 - b) compute satellite clock error with respect to GPS system time,
 - c) compute GPS satellite position at the GPS system time,
 - d) estimate propagation delays (ionospheric, tropospheric, receiver constant bias),
 - e) compute satellite to station range,
 - f) determine the user clock error (difference between instantaneous user clock time and

corrected GPS time).

- 3) Perform data smoothing for a single pass of raw time transfer measurements.
- 4) Data display and formatting.
- 5) Operator interface (via the televideo 920C terminal) for data base update (user location, receiver bias) and mode control.

The TTS 502 thus allows a user clock to be compared with the GPS system time. The differences are output to the televideo 920C CRT screen and (optionally) to external peripherals via an RS-232 output channel. Correction to UTC time may be performed by inputting linear slope and offset coefficients which represent the variation between GPS system time and UTC time.

TIME TRANSFER CONCEPT

The concept of time transfer using GPS satellites is illustrated in Figure 2. The GPS satellite system will ultimately consist of a space segment of eighteen satellites distributed in three orbital planes inclined to the Earth's equatorial plane. Each satellite contains onboard an atomic clock (Rubidium or Cesium). A GPS ground segment includes a Master Control Site (MCS) and five or more Monitor Sites (MS). The monitor sites receive transmissions from each of the GPS satellites, referred to a local clock, and retransmit this information to the MCS over secure data communication links. The MCS correlates the data and performs calculations to determine current satellite performance parameters, including clock performance, and uploads data to each GPS satellite on a daily or as required basis. This process is shown schematically in Figure 2 as an upload/download from the MCS to a GPS satellite on the left hand side of Figure 2.

Each GPS satellite continually transmits a message which repeats every six seconds. The message is available to users with special GPS receivers and contains a time signal, correction parameters between the particular GPS satellite clock and the GPS master clock, propagation correction parameters for ionospheric delay, the satellites ephemeris and clock age data. Other data in the message concerns the ephemerides of all the other GPS satellites in the constellation.

Daily, for each GPS satellite the U.S. Naval Observatory's (USNO) prototype TTS performs a comparison between the individual GPS satellite clocks and the USNO master clock (hereafter referred to as Universal Time Coordinated (UTC)). In addition, the USNO compares UTC and the GPS time system. This data (viz., the correction between UTC and GPS, and the correction between UTC and the GPS satellite clocks) is published by the USNO on a daily basis

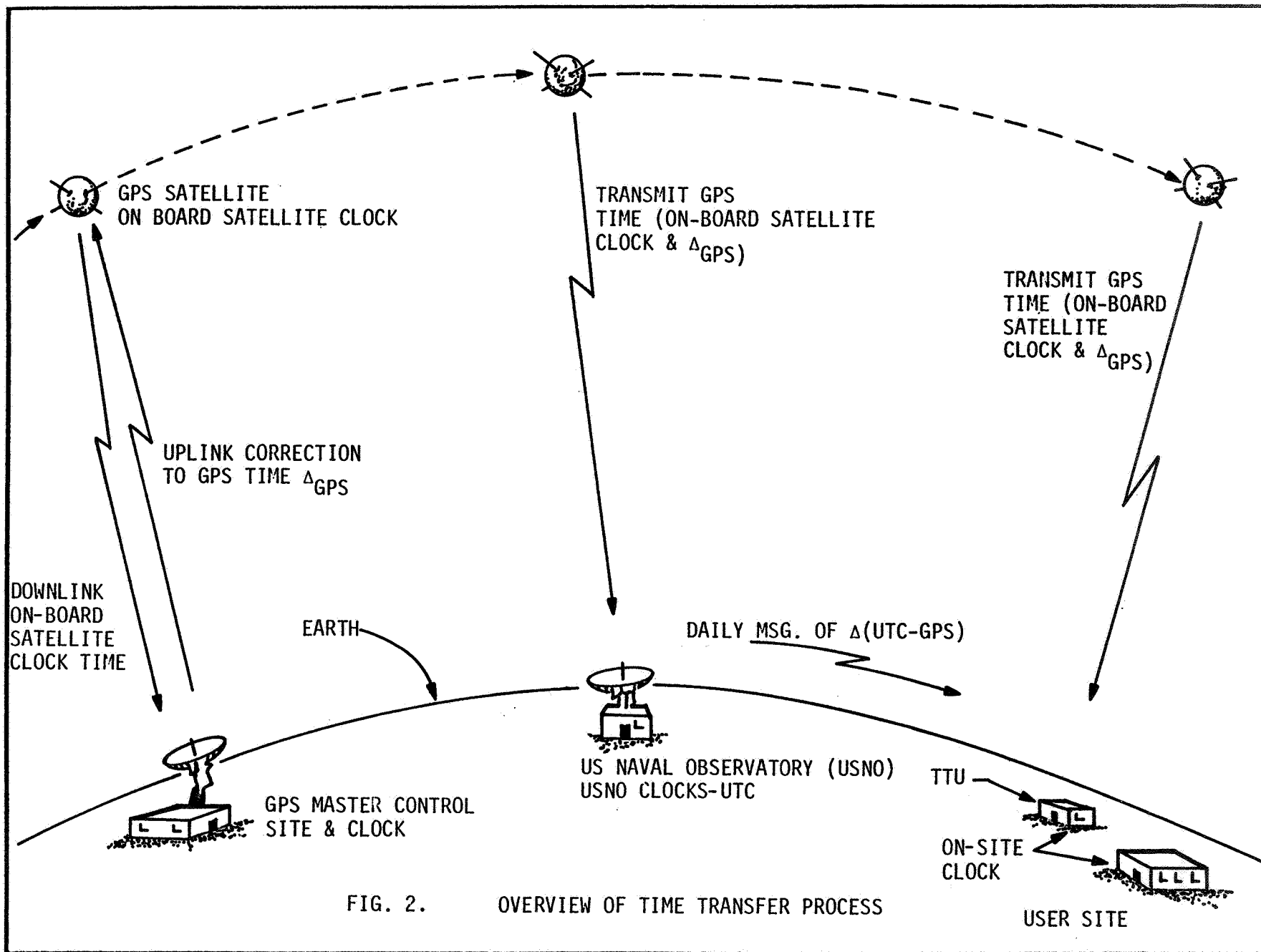

FIG. 2. OVERVIEW OF TIME TRANSFER PROCESS

via the USNO Time Service Series 4. This process is depicted in Figure 2 in the center of the figure.

As the GPS satellite becomes visible to the user site, the on-site TTS receives the GPS signal and compares the GPS time (via the onboard GPS satellite clock and GPS correction parameters) to the user's clocks. The TTS equipment and software perform a running comparison between the site clock and GPS time. The data from the USNO is then applied to correct the UTC time.

TEST PROCEDURES

During June 17 to 19 of 1982, tests of the STI TTS Model 502 were performed at the GPS MCS in Vandenburg, California and during August and September at the USNO in Washington, D.C. These tests established measurements of the fundamental accuracy of time transfer using the STI TTS 502 and the accuracy of the process of time transfer from a user clock to UTC time.

GPS MCS TESTS

In order to establish an accuracy baseline of the Time Transfer Unit, an accuracy test was performed at the GPS MCS. The test is shown schematically in Figure 3. Two TTS-502 receivers (serial #002 and 003) were set up in the GPS Master Site Integration Facility (MSIF) located at Vandenburg AFB. A USNO portable cesium clock (PC 837) was used as an intermediate standard for input to each TTS receiver. Time transfer observations were made via the time transfer TTS-502 receivers and the GPS system. These observations provided measurements of the offset between PC837 and GPS system time, as shown schematically as the output of a TTS receiver at the bottom of Figure 3. The observations were scheduled in accordance with the visibility of the GPS satellites at the MCS and to obtain a variety of time transfer measurements under all conditions (e.g. low and high elevation angles, day and night observations, etc.). The TTS-502 receivers were initialized to collect 10 minutes of data per visible GPS satellite. A round robin scheme provided for ten minute data collection on each GPS satellite (SV numbers 4, 5, 6, 8 and 9) in sequence. The TTS-502 smoothed the raw time transfer data, which were observed every six seconds throughout the ten minute data collection span, using a running 20 point linear least squares fit. A total of 149, ten minute data sets were observed during June 17 through 19.

During the same period, direct measurements of the offset between PC837 and GPS system time were obtained using the USNO 5328 counter, as shown in Figure 3. The counter measured, hourly, the offset between PC 837 and the Vandenburg Monitor Station (VMS) clock. Cable delays were measured by a 5370 Time Interval Counter to an accuracy of about 4 nsec. The difference between the VMS clock and GPS system time is monitored by GPS MCS personnel, as described in reference (5). A transformation was derived between PC837 and GPS system time using the USNO counter observations and the VMS-GPS

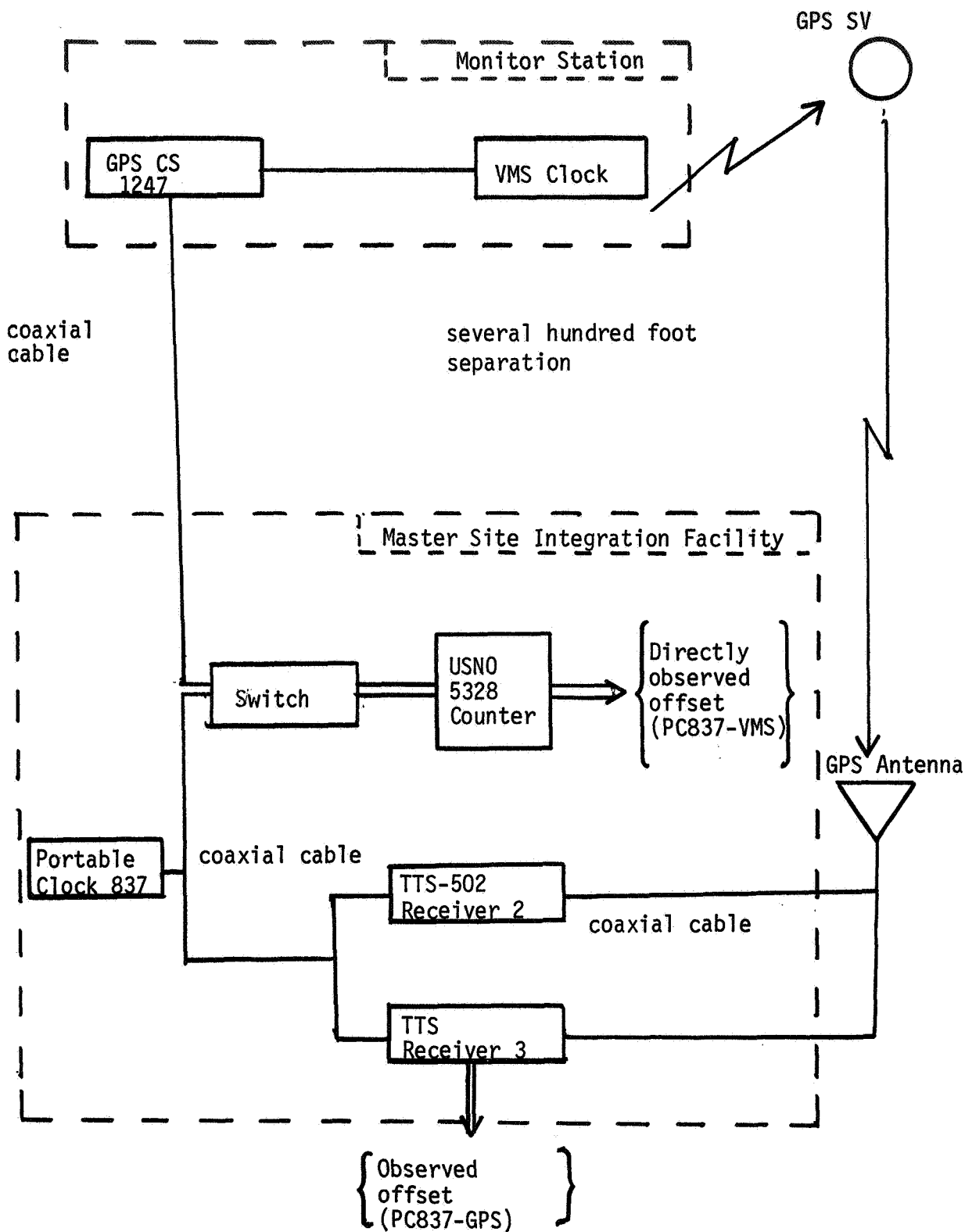

FIGURE 3: GPS MCS Accuracy Baseline Test

offset. The relation is:

$$(\Delta t)_{\text{PC837-GPS}} = (0.041147 \text{ nsec/min})(T - T_{\text{EPOCH}}) - 44531.7 \text{ nsec}$$

where $T_{\text{EPOCH}} = \text{day } 170, 4^{\text{h}}, 15^{\text{m}}, 0^{\text{s}}$ and T is the observation time. An uncertainty of ± 12.8 nsec is associated with the transformation, due to the errors associated with measuring the cable delays, noise in the USNO 5328 counter, and uncertainty in the GPS MCS determination of the relation between VMS time and GPS system time. The absolute error in the TTS-502 time transfer observations can be determined by an expression of the form,

$$(\text{TTS-502 Error}) = (\Delta t)_{\text{PC837-GPS}} - (\Delta t)_{\text{TTS-502 observations}}$$

where

$(\Delta t)_{\text{TTS-502 observations}}$ are the observations indicated as the output of the TTS-502 receivers (shown schematically at the bottom of Figure 3).

USNO VERIFICATION TESTS

Verification tests of the TTS-502 receiver, serial number 003, were performed at the USNO on August 19 through September 28 of 1982. The tests provided a measurement of the accuracy with which time transfer can be performed between UTC and GPS using the TTS-502 and the GPS satellite system.

The test compared the prototype TTU currently at the USNO with the TTS-502. In particular, the prototype USNO TTU is currently being used to perform time transfer between the GPS master clock to UTC time, and the individual GPS on-board satellite clocks to UTC time (Reference (3)). This is done at the USNO by connecting a physical UTC time signal into the prototype TTU and allowing the TTU to perform the time synchronization measurement. The results of these measurements are published daily by the USNO in a Time Series Report #4. The TTS-502 was simply set up beside the prototype TTU at the USNO. A UTC time signal was input to the TTS-502 as a system clock. Then, a comparison was made between the GPS time synchronization performed by the prototype TTU and that performed by the TTS-502. This test simply compares the operation of the prototype and new TTU units. Excluding observational noise which results directly from each TTU (viz. receiver noise, etc.), the time transfer measurements should be nearly identical, considering that the observational conditions are nearly identical (i.e., same GPS satellite, same elevation angle, same ionospheric delays, etc.)

A total of 154 passes of data were obtained for four GPS satellites (SV# 5, 6, 8 and 9). Each pass of data was smoothed by a linear least squares fit to result in a single smoothed time transfer observation. The analysis of these 154 smoothed observations is described in the next section.

TEST RESULTS

The results of both the GPS MCS tests and the USNO tests indicate that the TTS-502 receivers provide the capability to perform time transfer measurements to an absolute accuracy which is well within the 100 nanosecond budget for the receivers.

GPS MCS TEST RESULTS

Figure 4 shows a histogram of the data collected at the GPS MCS. The histogram includes all data collected during June 17 to 19, for receiver serial numbers 002 and 003, excluding GPS satellite number 4. Receiver #002 shows an absolute bias of -56.0 nsec with a standard deviation of 9.8 nsec. Receiver #003 exhibits a bias of -51.0 nsec with a standard deviation of 15.0 nsec. As shown on Figure 4, the one sigma uncertainty of the zero point calibration is ± 13 nsec.

Subsequent to the GPS MCS test, STI discovered a calibration error in the TTS-502 due to the algorithm used to correct for quantization effects. The resulting recalibration reduced the TTS-502 bias error by approximately 25 nanoseconds. Note that the STI recalibration was not fortuitous based on knowledge of the GPS MCS tests. STI personnel did not have the results of the GPS MCS test when the recalibration was performed. Thus, the absolute bias in the STI TTS-502 receivers is in the range of -26 to -56 nanoseconds with observational noise of 9 to 15 nanoseconds. It should be noted that the MCS GPS tests were conducted in an uncontrolled environment with variations in temperature, atmospheric pressure and humidity. Moreover, the data used to obtain the noise and bias figures, included observations of all GPS satellites (excluding number 4), day and night observations, and high and low elevation angles. Control of the ambient environment and careful selection of observations should decrease the observation noise.

USNO TEST RESULTS

Receiver #003 was moved to the USNO for further testing during August 19 through September 28. A total of 154 passes of time transfer data were collected in accordance with the previously described USNO test procedures. The data consisted of time transfer measurements between UTC and GPS system time using both the TTS-502 receiver and the USNO prototype receiver. Three basic analysis were performed including; (1) a comparison of the TTS-502 and USNO prototype receivers, (2) an analysis of the ability of a linear model to represent the TTS-502 time transfer data, and (3) an analysis of the accuracy with which the UTC-GPS offset can be predicted using a linear model. Each of these is described below.

First, a comparison was made between the TTS-502 time transfer data and that observed by the USNO prototype. Based on the results of the GPS MCS tests it was expected that the comparison of the TTS-502 and USNO prototype would

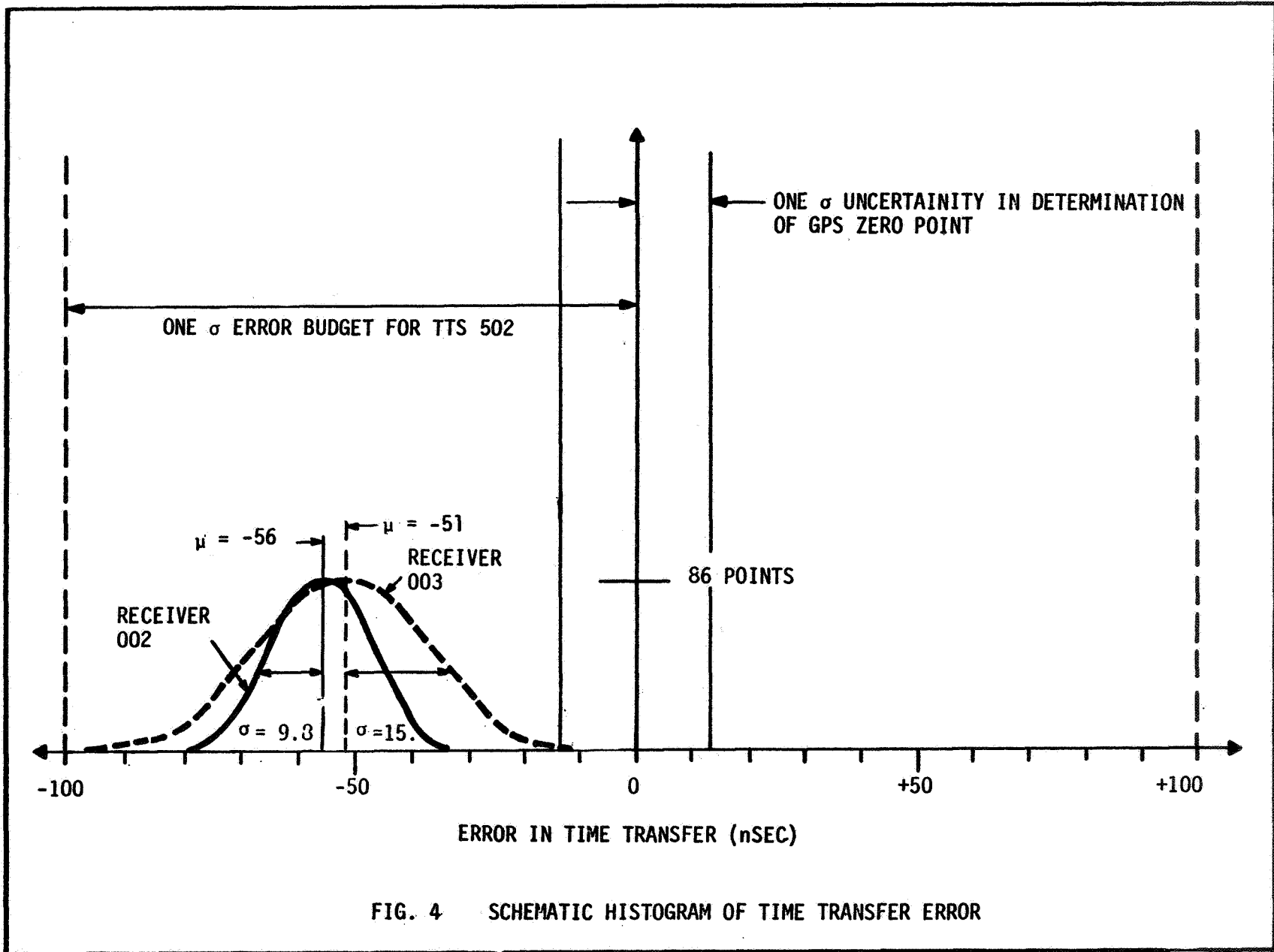

yield an offset within a factor of two of the expected error of the TTS-502.

A linear regression was performed between the TTS-502 data and the prototype data. The resulting linear relation is,

$$(\text{TTS-502 Offset}) = (1.000) (\text{Prototype Offset}) + 170.\text{nsec.}$$

Figure 5 shows a histogram of the residuals about the linear expression. Clearly, a constant bias of 170 nanoseconds exists between the TTS-502 and the prototype receivers. This is significantly larger than the measured (-51 nsec) bias of the TTS-502 receiver. The standard deviation of the residuals about the regression line was 8.1 nsec.

During the USNO testing, another time transfer receiver from the Naval Research Laboratory (NRL) was brought to the USNO by Mr. Jay Oaks. Initial results indicate that the TTS-502 compares well with the NRL receiver. Further tests are required to resolve the offset issue. STI plans to recalibrate the prototype receiver during December 1982.

The second analysis performed on the USNO data was to model the observed TTS-502 data by a linear model. The data were fit by linear regression over several data collection spans. Expressions were obtained of the form,

$$(\text{GPS} - \text{UTC Offset}) = A(\text{Observation Time} - \text{Epoch}) + B$$

where the observation time is the starting time of the tracking of a GPS satellite in Julian days (format DDDD.DD). The epoch was chosen as Modified Julian day number 45198.0. The quantity A is the slope of the variation of the GPS to UTC time scales (microseconds per day), and B is the offset (microseconds) between GPS and UTC time at epoch.

Linear regressions were performed using all satellite data for several data collection spans ranging from a few days to the entire data collection span of 40 days. For each regression, the standard deviation of the residuals about the regression equation was computed. The results are shown in Figure 6 which plots the standard deviation of the residuals as a function of the data collection span. It might be expected that the standard deviation would be small for short data collection intervals, indicating a "local fit" phenomena, and subsequently increasing and leveling off for the data collection span for which the linear model is valid. At some point, the standard deviation of the residuals would increase when a data span is reached for which the linear model becomes invalid. Such a phenomena is shown in Figure 6. The linear model provides a good fit for a data collection span of less than 35 days. Beyond that interval, the linear model seems to break down. Because of the abrupt change of the standard deviation of the residuals, it might be suspected that some change in the GPS time scale was effected at Modified Julian day number 45233. Similar changes in the GPS system time scale have occurred in the past. However, over a collection interval of up to 35 days, a linear relation provides a good model to represent the time transfer data.

COMPARISON OF PROTOTYPE/TTS-502

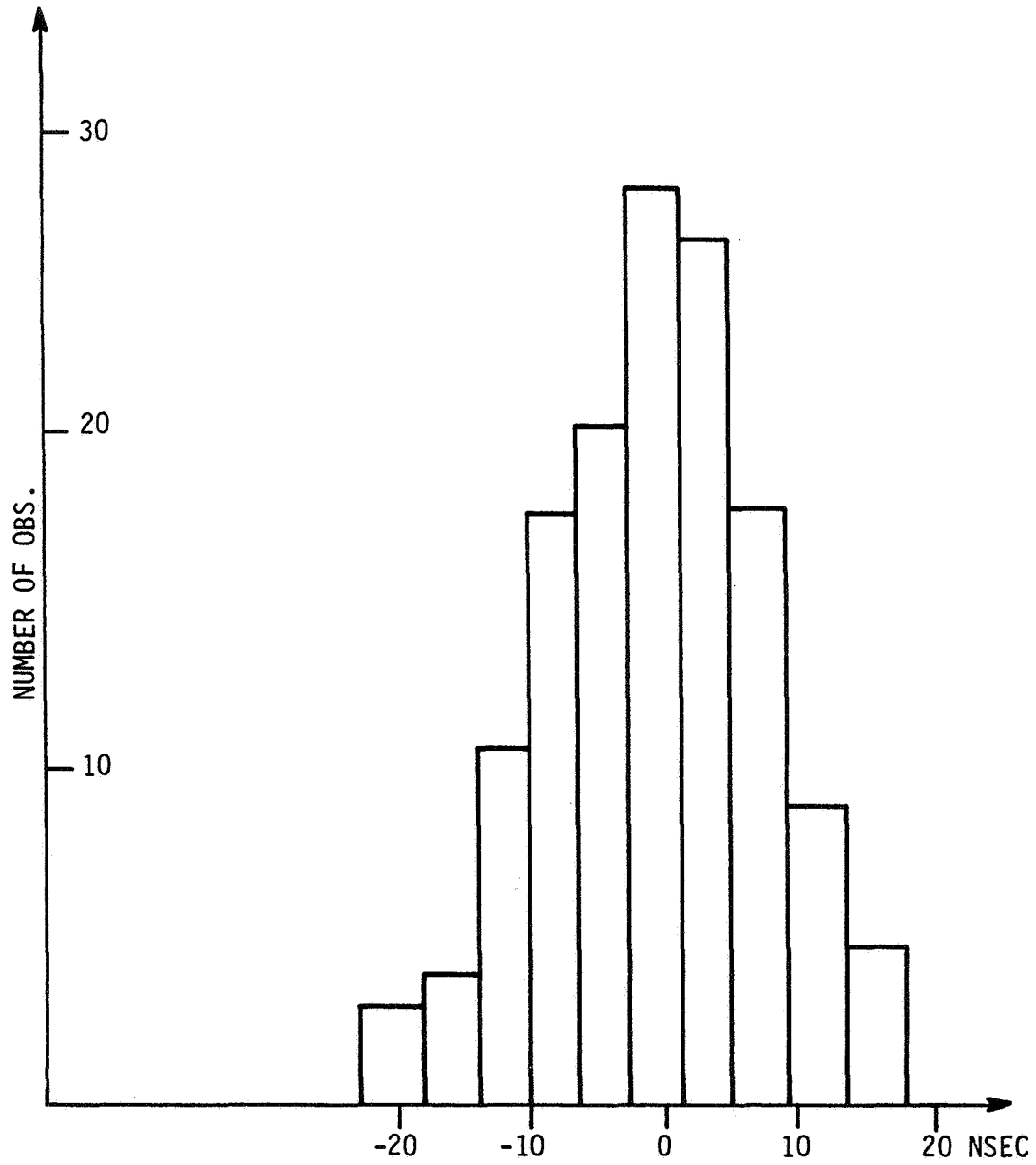

SLOPE = 1.000
OFFSET = 170 NSEC
 $\sigma = 8.1$ NSEC

FIG. 5 HISTOGRAM OF RESIDUALS ABOUT THE LINEAR REGRESSION OF PROTOTYPE/TTS-502

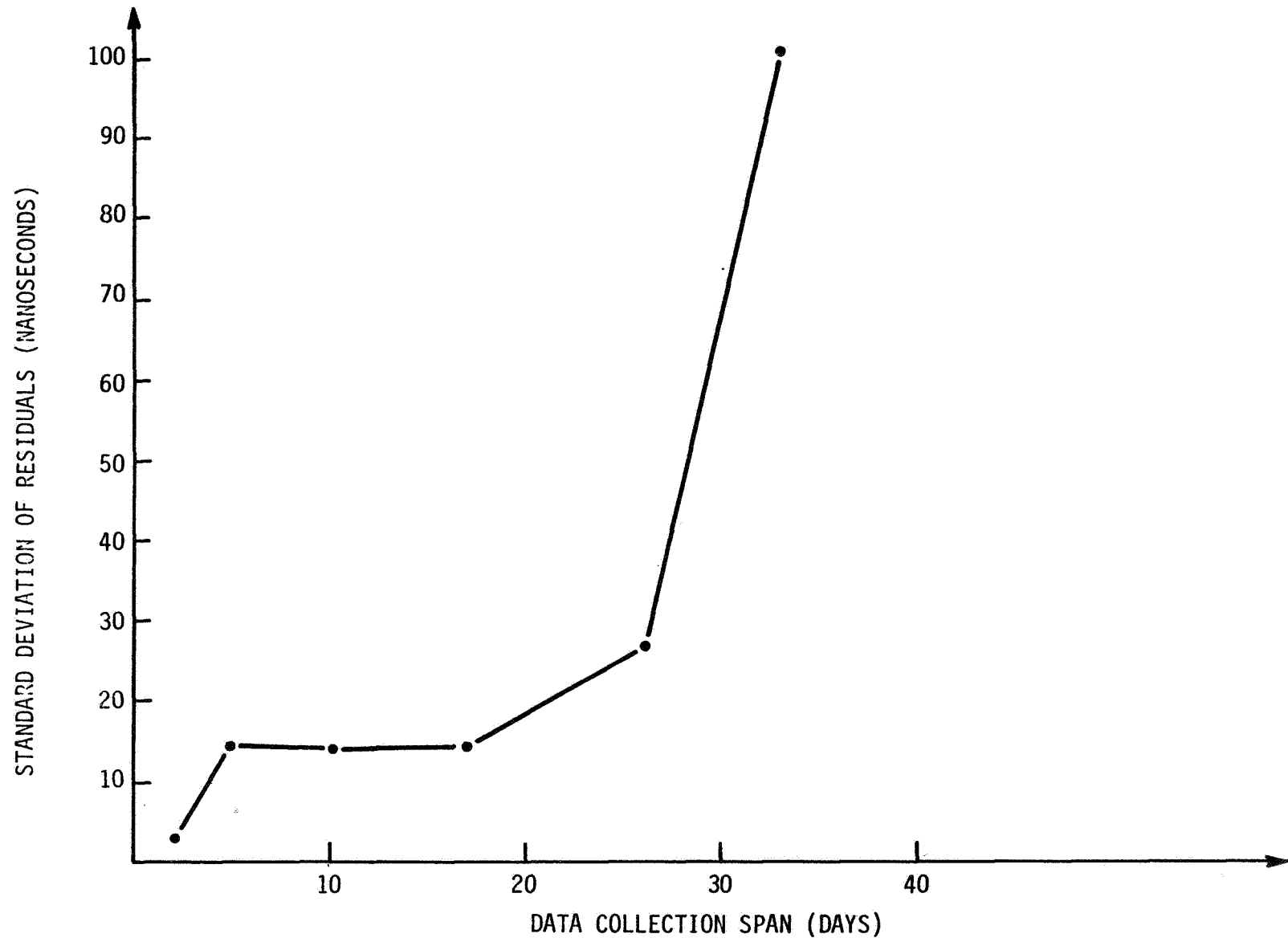

FIG. 6 STANDARD DEVIATION OF THE RESIDUALS ABOUT THE REGRESSION VS COLLECTION

The final analysis of the USNO data was an investigation of the ability of a linear model to predict the offset between GPS and UTC time. Specifically, the TTS-502 data was fit by a linear regression over a 26 day subinterval of the 40 day span of collected time transfer data. An equation of the form,

$$(\text{GPS} - \text{UTC Offset}) = A (\text{Observation Time} - 45198.0) + B$$

was obtained by least squares fit of the TTS-502 data for Modified Julian days 45198 to 45224. Five separate regression equations were obtained, one for each GPS satellite (numbers 5, 6, 8 and 9) and one regression which included all four satellites. Figure 7 lists the regression equation coefficients, the number of observations included in the fit, and the standard deviation of the residuals about the regression equation.

Each of these equations, or linear models for a 26 day span of time transfer observations, was used to predict the GPS-UTC offset for times beyond the end of the fitting interval (i.e., beyond Modified Julian day 45224). These predictions were compared against the actual TTS-502 observational data beyond day 45224. The comparison,

$$\text{Prediction Error} = (\text{Predicted Offset}) - (\text{TTS-502 Observed Offset})$$

was made to determine how the linear fit degrades beyond the end of the fitting interval. Figure 8 graphs the prediction error versus prediction interval (observation time -45224) for all four GPS satellites. The error degrades quadratically with prediction interval. However, a linear model yields a prediction error of less than 100 nanoseconds for a prediction interval of four to five days, using a 26 day calibration span.

GPS SV NUMBER	NUMBER OF OBSERVATIONS	REGRESSION EQUATION COEFFICIENTS		STANDARD DEVIATION RESIDUALS (μSEC)
		SLOPE (A) μSEC	OFFSET (B) μSEC	
5	17	0.110	-39.5	0.013
6	27	0.109	-39.1	0.017
8	27	0.111	-39.2	0.041
9	19	0.110	-39.1	0.019
ALL	90	0.110	-39.1	0.027

FIG. 7 REGRESSION EQUATIONS FOR A 26 DAY OBSERVATION SPAN

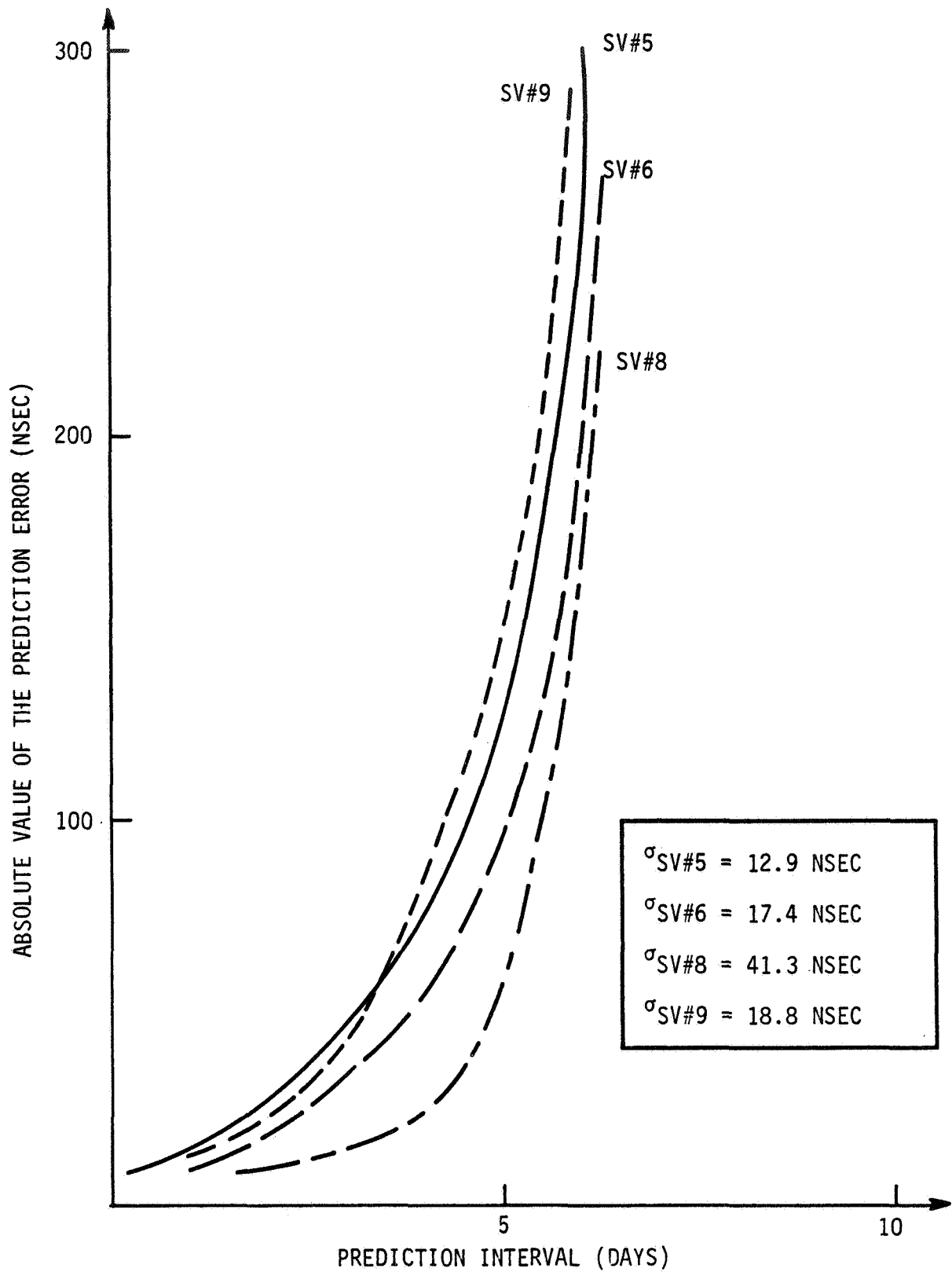

FIG. 8 PREDICTION ERROR VERSUS PREDICTION INTERVAL FOR 26 DAY CALIBRATION INTERVAL

ACKNOWLEDGEMENTS

The authors would like to acknowledge the help and advice of Dr. Winkler of the USNO in obtaining the USNO observational data. Mr. R. Sholley of HRB-Singer provided assistance in the final data reductions. Finally, Mr. F. Varnum of the GPS MCS supported the collection of the GPS MCS data. This work was supported by the Naval Research Laboratory.

REFERENCES

- (1) Global Positioning System, The Institute of Navigation, Washington, D.C., 1980.
- (2) Putkovich, K., "Initial Test Results of USNO GPS Time Transfer Unit", Proc. 34th Annual Frequency Control Symposium, USAERADCON, Ft. Monmouth, NJ 07703, May 1980.
- (3) System Specification for the NAVSTAR Global Positioning System, USAF Space and Mission Systems Organization, 31 January 1979.
- (4) Van Dierendonck, A. J., Hau, Q. D., McLean, J. R., and Denz, "Time Transfer Using NAVSTAR GPS", Stanford Telecommunications, Inc., Technical Memorandum, STI-TM-9828, 1 September 1981, 1195 Bordeaux Drive, Sunnyvale, CA 94086.
- (5) Varnum, F. and Chaffee, J., "Data Processing at the Global Positioning System Master Control Station", paper presented at the International Doppler Positioning Symposium in New Mexico, 1981.

QUESTIONS AND ANSWERS

MR. D. W. ALLAN, National Bureau of Standards

A question regarding the bias and the distribution of that bias: The 9.8 and 15 nanosecond widths, were those calculated from the 10-minute averages for all of the data taken for a receiver? I'm not sure how that 9.8 nanosecond width was calculated.

MR. D. L. HALL, HRB-Singer, Inc.

Yes. Basically, we used each data point as a smooth data point that contained for, say, a 10-minute span, that 9.8

MR. ALLAN:

So each data point was a 10-minute average?

MR. HALL:

That's right.

MR. ALLAN:

And that's the distribution of those 10-minute averages?

MR. HALL:

That's correct.

MR. ALLAN:

Okay. I think in principle, from the work we have done at the Bureau, we have seen distributions between receivers looking at the same satellite that are roughly on an order of magnitude better than that, and I wonder if you have any feeling for the source of that distribution?

MR. HALL:

No. I did want to say, though, that those numbers represented observations that were taken both at low elevations, high elevations, all times of the night and day, and so it is not the best case. When we looked at using, say, a single satellite, using night observations, high elevations, we could certainly reduce those noise figures by certainly 4 or 5 nanoseconds but not by an order of magnitude.

MR. ALLAN:

That certainly explains a lot of it.