

General Disclaimer

One or more of the Following Statements may affect this Document

- This document has been reproduced from the best copy furnished by the organizational source. It is being released in the interest of making available as much information as possible.
- This document may contain data, which exceeds the sheet parameters. It was furnished in this condition by the organizational source and is the best copy available.
- This document may contain tone-on-tone or color graphs, charts and/or pictures, which have been reproduced in black and white.
- This document is paginated as submitted by the original source.
- Portions of this document are not fully legible due to the historical nature of some of the material. However, it is the best reproduction available from the original submission.

(NASA-CR-168064) MOBILE RADIO ALTERNATIVE
SYSTEMS STUDY SATELLITE/TERRRESTRIAL (HYBRID)
SYSTEMS CONCEPTS (GENERAL ELECTRIC CO.)
273 p HC A12/RF A01

CSC1 17B

W84-10404

Unclass

63/32 36101

MOBILE RADIO ALTERNATIVE SYSTEMS STUDY

Volume III

SATELLITE/TERRRESTRIAL (HYBRID) SYSTEMS CONCEPTS

JUNE 1983

PREPARED FOR
NASA-LEWIS RESEARCH CENTER
CLEVELAND, OHIO

CONTRACT NAS3-23244

General Electric Company

Corporate Research and Development
Schenectady, New York

Space Systems Division
Philadelphia, Pennsylvania

John D. Klesling
Roy E. Anderson

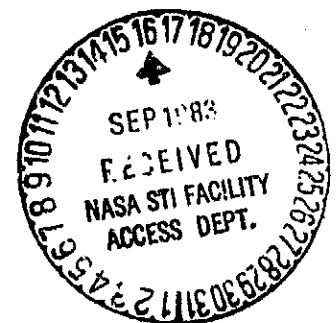

ACKNOWLEDGMENTS

Many persons participated in the Mobile Radio Alternatives Systems Study, or contributed directly to its performance. The efforts of the following persons are deeply appreciated:

General Electric Corporate Research and Development:

Roy E. Anderson
Howard L. Lester
William T. Tucker
Carolyn B. Morgan
Richard L. Frey
Richard J. Herbs

General Electric Space Division

John D. Kiesling
Charles C. Allen

General Electric Mobile Communications Division

Norman S. Cromwell
Ronald C. Sisson
John A. Mallen
Thomas R. Lusk

ECOsystems International

Peter A. Castruccio
James Cooper

Loats Associates

Harry Loats
Donald G. Lloyd

Comsat General Corporation

Frederick L. Hofmann

Telocator of America

Thomas Lamoureux

United States Independent Telephone Association

Charles Demek

The staff at NASA-Lewis Research Center provided invaluable guidance and support throughout the study. Their friendly and cooperative participation is deeply appreciated. Staff members most closely associated with the project are:

Steven M. Stevenson
Jack A. Salzman
Bruce Leroy

PREFACE

The Mobile Radio Alternatives Systems Study addressed the needs for mobile communications in the non-urban areas of the United States between the present and the year 2000, and considered two ways of fulfilling the needs: by terrestrial systems only and by a combination of terrestrial and satellite systems. Results of the study are presented in three volumes.

Volume I defines the functions and services that will be needed, and presents estimates of the mobile radio traffic that will be generated and the geographical distribution of the traffic.

Volume II describes and analyzes the performance and cost of terrestrial systems concepts for meeting the needs described in Volume I.

Volume III describes and analyzes the performance and cost of satellite-aided mobile radio systems concepts designed to serve that portion of the needs that may not be fulfilled by terrestrial systems. The volume includes a discussion of regulatory and institutional aspects of satellite land mobile communications.

A companion report, "Non-Urban Mobile Radio Demand Forecast," Final Report, June 25, 1982, was prepared by ECOsystems International Incorporated under a subcontract to the study. The report is available from the National Technical Information Service, Springfield, Virginia, 22161.

The Mobile Radio Alternatives Systems Study was divided into tasks. The study results were prepared for publication in a single volume with the results of each task presented as a numbered section. It became apparent that the report would serve its readers better if it were divided into three volumes as described in the Preface. The section numbering intended for the single volume is retained in this volume.

TABLE OF CONTENTS

| <u>Section</u> | <u>Page</u> |
|--|-------------|
| 4 HYBRID (SATELLITE) SYSTEM | |
| 4.1 Satellite System Architecture | 4-1 |
| 4.1.1 System Elements | 4-1 |
| 4.1.2 LMSS Unique Features | 4-1 |
| 4.1.3 LMSS Services | 4-3 |
| 4.1.4 Requirements and Critical Parameters | 4-4 |
| 4.1.4.1 General Requirements | 4-4 |
| 4.1.4.2 Particular Requirements | 4-6 |
| 4.1.4.3 Critical Parameters | 4-7 |
| 4.1.5 Frequency Plans | 4-8 |
| 4.1.6 Geometric Factors | 4-9 |
| 4.1.6.1 Satellite Orbital Locations | 4-9 |
| 4.1.6.2 Differential Range | 4-11 |
| 4.1.7 Strategy for Satellite Concepts | 4-12 |
| 4.1.7.1 Introduction | 4-12 |
| 4.1.7.2 Satellite Capacity | 4-12 |
| 4.1.7.3 Link Performance | 4-13 |
| 4.2 Satellite Concepts | |
| 4.2.1 Satellite Concept A | 4-17 |
| 4.2.1.1 Frequency Plan, Beam Plan and Capacity | 4-17 |
| 4.2.1.2 Transponder Arrangement | 4-20 |
| 4.2.1.3 Signalling and Switching and Network Control | 4-22 |
| 4.2.1.4 Weight and Power Summary | 4-25 |
| 4.2.2 Satellite Concept B | 4-30 |
| 4.2.2.1 Frequency Plan, Beam Plan, and Capacity | 4-30 |
| 4.2.2.2 Transponder Arrangement | 4-32 |
| 4.2.2.3 Signalling and Switching and Network Control | 4-32 |
| 4.2.2.4 Weight and Power Summary | 4-34 |
| 4.2.3 Satellite Concept C | 4-39 |
| 4.2.3.1 Frequency Plan, Beam Plan and Capacity | 4-39 |
| 4.2.3.2 Transponder Arrangement | 4-39 |
| 4.2.3.3 Signalling, Switching and Network Control | 4-39 |
| 4.2.3.4 Weight and Power Summary | 4-40 |
| 4.2.4 Satellite Concept D | 4-44 |
| 4.2.4.1 Frequency Plan, Beam Plan, Switching Plan and Capacity | 4-44 |
| 4.2.4.2 Transponder Arrangement | 4-46 |
| 4.2.4.3 Signalling, Switching and Network Control | 4-50 |
| 4.2.4.4 Weight and Power Summary | 4-52 |

TABLE OF CONTENTS (Cont.)

| <u>Section</u> | | <u>Page</u> |
|----------------|---|-------------|
| | 4.2.5 Concept D' | 4-60 |
| | 4.2.5.1 Introduction | 4-60 |
| | 4.2.5.2 Frequency Plan, Beam Plan and Capacity | 4-60 |
| | 4.2.5.3 Transponder Arrangement | 4-60 |
| | 4.2.5.4 Signalling, Switching and Network Control | 4-61 |
| | 4.2.5.5 Weight and Power Summary | 4-62 |
| | 4.2.6 Summary of Concepts | 4-68 |
| 4.3 | Space System Investment | 4-71 |
| | 4.3.1 Cost Analysis | 4-71 |
| | 4.3.1.1 Approach | 4-71 |
| | 4.3.1.2 Limitations | 4-74 |
| | 4.3.1.3 Capacity Assumptions | 4-74 |
| | 4.3.2 Space System Costs | 4-79 |
| | 4.3.2.1 Investment | 4-79 |
| | 4.3.2.2 Bogey Weight Model | 4-79 |
| | 4.3.2.3 Concept Model Costs | 4-80 |
| | 4.3.2.4 Total Space Investment | 4-94 |
| 4.4 | Subscriber Charges | 4-100 |
| | 4.4.1 Methodology | 4-100 |
| | 4.4.2 General Results | 4-105 |
| | 4.4.2.1 Likely Market Projection | 4-106 |
| | 4.4.2.2 Optimistic Market Projection | 4-107 |
| | 4.4.2.3 Conservative Market Projection | 4-109 |
| | 4.4.3 Particular Results | 4-109 |
| | 4.4.3.1 Subscriber Charge Methodology | 4-109 |
| | 4.4.3.2 Subscriber Typical Charges | 4-114 |
| | 4.4.4 Discussion and Interpretation of Results | 4-120 |
| | 4.4.4.1 Introduction | 4-120 |
| | 4.4.4.2 Space Segment Investment | 4-121 |
| | 4.4.4.3 Fixed Link Operation | 4-125 |
| | 4.4.4.4 Power and Margin | 4-125 |
| | 4.4.4.5 Modulation and Channel Bandwidth | 4-130 |
| | 4.4.4.6 Pedestrian Antenna | 4-131 |
| 4.5 | Gateway terminals | 4-134 |
| | 4.5.1 Introduction | 4-134 |
| | 4.5.2 Dial-Up Telephone | 4-135 |
| | 4.5.3 Leased Lines | 4-138 |
| | 4.5.4 Radio Relay | 4-140 |
| | 4.5.5 Earth Station Gateways | 4-143 |
| 4.6 | Mobile Radios | 4-156 |
| | 4.6.1 Transceivers | 4-156 |
| | 4.6.1.1 Introduction | 4-156 |
| | 4.6.1.2 Cellular - Compatible Transceiver | 4-156 |
| | 4.6.1.3 Dispatch and Radio Telephone (Stand-Alone) Transceiver | 4-161 |
| | 4.6.1.4 Interactive Data/Position Location Transceiver | 4-166 |
| | 4.6.1.5 Signalling Architecture | 4-168 |

TABLE OF CONTENTS (Cont.)

| <u>Section</u> | <u>Page</u> |
|--|-------------|
| 4.6.2 Mobile Antennas | 4-173 |
| 4.6.2.1 Introduction | 4-173 |
| 4.6.2.2 Mobile Vehicle Antennas Requirements | 4-174 |
| 4.6.2.3 Fixed Antenna Concept | 4-179 |
| 4.6.2.4 Mechanically Steerable Antenna Concept | 4-188 |
| 4.6.2.5 Electrically Steerable Antenna Concept | 4-190 |
| 4.6.2.6 Pedestrian Antenna Concept | 4-195 |
| 4.6.3 Mobile Radio Costs | 4-199 |
| 4.6.3.1 Introduction | 4-199 |
| 4.6.3.2 Transceiver Costs | 4-200 |
| 4.7 Total Subscriber Charges | 4-205 |
| 4.8 Implementation Scenario | 4-209 |
| 4.8.1 Recommended Approach | 4-209 |
| 4.8.2 Development Scenario | 4-211 |
| 4.8.3 Institutional and Regulatory Assumptions | 4-214 |
| 4.8.4 Technology Improvements | 4-220 |
| 4.8.4.1 Introduction | 4-220 |
| 4.8.4.2 Space Segment | 4-221 |
| 4.8.4.3 Gateway | 4-221 |
| 4.8.4.4 Mobile Radio | 4-223 |
| 4.9 Spacecraft Configuration | 4-225 |
| 4.9.1 Introduction | 4-225 |
| 4.9.2 Launch Configuration | 4-225 |
| 4.9.3 Orbital Configuration | 4-229 |
| 4.10 Regulatory and Institutional Aspects | 4-232 |
| 4.10.1 Regulatory Aspects | 4-232 |
| 4.10.1.1 Frequency Allocation Considerations | 4-232 |
| 4.10.2 FCC Policies | 4-234 |
| 4.10.2.1 Allocation Criteria of FCC | 4-234 |
| 4.10.2.2 FCC Criteria Applied to Land Mobile Satellite Service | 4-234 |
| 4.10.2.3 Status of Frequency Allocations | 4-239 |
| 4.10.2.4 International Coordination | 4-240 |
| 4.10.2.5 Commentary on Regulatory Aspects | 4-240 |
| 4.10.3 Institutional Aspects | 4-241 |
| 4.10.3.1 Institutions That Provide Services | 4-241 |
| 4.10.3.2 Institutional Arrangement Features | 4-242 |
| 4.10.3.3 System Financing and Development | 4-243 |
| Appendix A — Satellite Mobile Signal Propagation | A-1 |
| Appendix B — Experimental Verification of Terrestrial and Satellite Propagation Characteristics | B-1 |
| Appendix C — Comments by COMSAT on Institutional Considerations | C-1 |

LIST OF FIGURES

| <u>Figure No.</u> | | <u>Page</u> |
|-------------------|---|-------------|
| 4.1-1 | Current FCC Frequency Allocation and NASA Proposed Revision | 4-9 |
| 4.1-2 | Satellite Configuration Summary | 4-13 |
| 4.1-3 | Nominal Performance Levels | 4-16 |
| 4.2-1 | Concept A Frequency Plan | 4-17 |
| 4.2-2 | Satellite Antenna Beam Coverage of U.S. from 90 ⁰ W | 4-18 |
| 4.2-3 | Satellite Antenna Beam Coverage of U.S. from 120 ⁰ W | 4-19 |
| 4.2-4 | Concept A Transponder Arrangement | 4-20 |
| 4.2-5 | Concept A Common Signalling Channel Arrangement | 4-23 |
| 4.2-6 | One Beam Satellite, Common Signalling Channel Requirements Voice | 4-25 |
| 4.2-7 | Concept A Antenna and Receiver Weight and Power | 4-26 |
| 4.2-8 | Concept A Transmitter Weight and Power | 4-27 |
| 4.2-9 | Concept A Weight and Power Summary | 4-29 |
| 4.2-10 | Concept B Antenna Coverage | 4-30 |
| 4.2-11 | Concept B Frequency Plan | 4-31 |
| 4.2-12 | Concept B Transponder Concept | 4-33 |
| 4.2-13 | Concept B Common Signalling Channel Arrangement | 4-34 |
| 4.2-14 | Gateway Terminal Block Diagram | 4-35 |
| 4.2-15 | Concept B Antenna and Receiver Weights and Powers | 4-36 |
| 4.2-16 | Transmitter Weights and Powers | 4-37 |
| 4.2-17 | Concept B Weight-Power Summary | 4-38 |
| 4.2-18 | Concept C Frequency Plan | 4-39 |
| 4.2-19 | Concept C Antenna and Receiver Weight and Power | 4-41 |
| 4.2-20 | Concept Transmitter Weight and Power | 4-42 |
| 4.2-21 | Concept C Weight-Power Summary | 4-43 |
| 4.2-22 | Concept D Antenna Beam Coverage | 4-44 |
| 4.2-23 | Concept D Frequency Plan | 4-45 |
| 4.2-24 | Antenna Concept for Combined UHF & S-Band Operation | 4-47 |
| 4.2-25 | Concept D Transponder Concept | 4-49 |
| 4.2-26 | Concept D FDMA Channelization Network Concept | 4-51 |
| 4.2-27 | Concept D Communications and Signalling Arrangements | 4-53 |
| 4.2-28 | Concept D Antenna and UHF Receiver Weight and Power | 4-54 |
| 4.2-29 | Concept D S-Band Receiver Weight and Power | 4-56 |
| 4.2-30 | Concept D Transmitter Weight and Power | 4-57 |
| 4.2-31 | Concept D Transmitter Weight and Power Estimates | 4-58 |
| 4.2-32 | Concept D Weight-Power Summary | 4-59 |
| 4.2-33 | Concept D' Frequency Plan | 4-61 |
| 4.2-34 | Concept D' Transponder Concept | 4-62 |
| 4.2-35 | Concept D' Antenna and Receiver Weight and Power | 4-64 |
| 4.2-36 | Concept D' Ku Band Transmitter Assembly | 4-65 |
| 4.2-37 | Concept D' Transmitter Weight and Power | 4-66 |
| 4.2-38 | Concept D' Weight and Power Summary | 4-67 |
| 4.2-39 | Summary of Concept Characteristics | 4-69 |

LIST OF FIGURES (Cont.)

| <u>Figure No.</u> | | <u>Page</u> |
|-------------------|--|-------------|
| 4.3-1 | Cost Methodology • | 4-73 |
| 4.3-2 | Total Service Demand, Erlangs | 4-76 |
| 4.3-3 | Total Market Projection (Equivalent 4 KHz Circuits) | 4-78 |
| 4.4-1 | Space Segment Investment versus Equivalent 4 KHz Circuits for Various UHF Satellite Powers. | 4-105 |
| 4.4-2 | Equivalent Trunk Cost versus Circuit-Years for Likely Market Projection | 4-107 |
| 4.4-3 | Equivalent Trunk Cost versus Circuit-Years for Optimistic Market Projection, First Generation | 4-108 |
| 4.4-4 | Equivalent Trunk Cost versus Circuit-Years for Optimistic Market Projection, Second Generation | 4-108 |
| 4.4-5 | Equivalent Trunk Cost Versus Circuit-Years for Conservative Market Projection, First Generation | 4-110 |
| 4.4-6 | Equivalent Trunk Cost versus Circuit-Years for Conservative Market Projection, Second Generation (P=2, T=F=1) | 4-110 |
| 4.4-7 | Isolation versus Axial Ratio | 4-128 |
| 4.4-8 | Space Segment Investment vs. Spacecraft Weight | 4-128 |
| 4.5-1 | Concept for Satellite Access via a Gateway Terminal | 4-135 |
| 4.5-2 | Representative TELCO Service and Rates in Cails per Minute versus Busy Hour Capacity in Erlangs | 4-139 |
| 4.5-3 | Lease AT&T Lines, A-B Cities, Cost per Month, Per Fully Utilized Minute with Two Termination Cost | 4-141 |
| 4.5-4 | Leased AT&T Lines, A-B Cities, With Terminations; Call Cost per Minute, Erlangs | 4-142 |
| 4.5-5 | Radio Relay Cost versus Traffic Intensity | 4-145 |
| 4.5-6 | Simplified Block Diagram of Gateway Terminal | 4-146 |
| 4.5-7 | HPA Output Power vs Number of Simultaneous Channels for Both SSB and FM and For Different Numbers of Satellite Beams | 4-149 |
| 4.5-8 | Cost per Minute vs. Erlang for Gateway Terminals | 4-152 |
| 4.5-9 | Summary of Comparisons with Gateway | 4-153 |
| 4.6-1 | AMPS Vehicle Transceiver (a) and RF Compatible Unit (b) | 4-157,158 |
| 4.6-2 | Typical Frequency Synthesizer for Cellular Radio | 4-160 |
| 4.6-3 | Radio Telephone or Trunking (Stand-Alone) Transceiver | 4-162 |
| 4.6-4 | Example Stand-Alone Dispatch or Radio Telephone Transceiver (with frequency lock). | 4-165 |
| 4.6-5 | Interactive Data Transceiver | 4-167 |
| 4.6-6 | Typical Terrestrial Mobile Radio System | 4-168 |
| 4.6-7 | Polarization Isolation versus Axial Ratio | 4-175 |
| 4.6-8 | Equivalent Atmospheric Temperatures as a Function of Frequency and Angle From Azimuth | 4-176 |
| 4.6-9 | Antenna Geometry | 4-177 |

LIST OF FIGURES (Cont.)

| <u>Figure</u> | | <u>Page</u> |
|---------------|--|-------------|
| 4.6-10 | Candidate Fixed Antennas | 4-179 |
| 4.6-11 | Typical Elevation Pattern For Antennas Having Omnidirectional Coverage in Azimuth | 4-182 |
| 4.6-12 | Bent, Crossed Dipole Antenna and Cup | 4-183 |
| 4.6-13 | Fixed Antenna Concept Sketch | 4-184 |
| 4.6-14 | S-Band Patterns of Fixed Antennas (a) and (b) | 4-186 |
| 4.6-14 | S-Band Patterns of Fixed Antennas (a) and (b) (Cont.) | 4-187 |
| 4.6-15 | Helix (a) and Yagi (b) Steerable Antenna Concepts | 4-189 |
| 4.6-16 | Microstrip Antenna Concept for Electronic Steering | 4-192 |
| 4.6-17 | Microstrip Elements, Element Pattern, (a) and "Sandwich" Construction, (b) | 4-193 |
| 4.6-18 | Beam Forming Network of Phased Array | 4-194 |
| 4.6-19 | Wheeler Type Linear Array Antenna (Linearly Polarized) | 4-196 |
| 4.6-20 | Outline Sketch of Wheeler Antenna | 4-197 |
| 4.6-21 | Pedestrian High Gain Antenna | 4-198 |
| 4.6-22 | Mobile Radio Cost Characteristics | 4-203 |
| | | |
| 4.8-1 | LMSS Development Scenario | 4-213 |
| | | |
| 4.9-1 | Orbital Geometry | 4-226 |
| 4.9-2 | STS Configuration, End View | 4-227 |
| 4.9-3 | STS Configuration, Side View | 4-228 |
| 4.9-4 | Orbital Configuration | 4-230 |

LIST OF TABLES

| <u>Table No.</u> | | <u>Page</u> |
|------------------|--|-------------|
| 4.1-1 | Geometric Factors for CONUS and Offshore | 4-10 |
| 4.1-2 | Packet Guard Time Uncertainty | 4-12 |
| 4.2-1 | Concept A Common Signalling Channel Requirements, Voice | 4-23 |
| 4.2-2 | Nominal Satellite/Gateway Link Performance for Concept D' | 4-61 |
| 4.3-1 | Truck Trailer Trunk Requirements for Interactive Data and Position Location | 4-75 |
| 4.3-2 | Bogey Weight Model | 4-81 |
| 4.3-3 | Technology Indices | 4-81 |
| 4.3-4 | Communications Power Complexity Factors | 4-81 |
| 4.3-5 | Spacecraft Bus Complexity Factors | 4-82 |
| 4.3-6 | Concept A Recurring Cost | 4-83 |
| 4.3-7 | Concept A Nonrecurring Cost | 4-84 |
| 4.3-8 | Concept B Recurring Cost | 4-86 |
| 4.3-9 | Concept B Nonrecurring Cost | 4-87 |
| 4.3-10 | Concept C Recurring Cost | 4-88 |
| 4.3-11 | Concept C Nonrecurring Cost | 4-89 |
| 4.3-12 | Concept D' Recurring Cost | 4-90 |
| 4.3-13 | Concept D' Nonrecurring Cost | 4-91 |
| 4.3-14 | Concept D Recurring Cost | 4-92 |
| 4.3-15 | Concept D Nonrecurring Cost | 4-93 |
| 4.3-16 | Recurring cost Summary (SAMSO) | 4-95 |
| 4.3-17 | Nonrecurring Cost Summary (SAMSO) | 4-96 |
| 4.3-18 | Space Investment (millions of 1982 dollars) | 4-98 |
| 4.4-1 | Payload Schedule Exponential Capacity Growth | 4-101 |
| 4.4-2 | Payload Schedule for Constant Capacity | 4-104 |
| 4.4-3 | Trunk Efficiency Bases on Erlang "B" and "Likely" Traffic Projection Distribution | 4-112 |
| 4.4-4 | Subscriber Call-Minute Charges for the "Likely" Market Projection (P=2, T=F=1) | 4-115 |
| 4.4-5 | Typical Monthly Subscriber Charge (Cm) Dollars Based on "Likely" Traffic Projection (P=2, T=F=1) | 4-116 |
| 4.4-6 | Subscriber Call-Minute Charge for "Optimistic" Traffic Projection (P=2, T=F=1) | 4-119 |
| 4.4-7 | Typical Monthly Subscriber Charge, Dollars, Based on "Optimistic" Traffic Projection, (P=2, T=F=1) | 4-120 |
| 4.4-8 | Subscriber Call-Minute Charge for "Conservative" Traffic Projection (P=2, T=F=1) | 4-121 |
| 4.4-9 | Typical Monthly Subscriber Charge, Dollars Based on "Conservative" Traffic Projection, | 4-122 |

LIST OF TABLES (Cont.)

| <u>Table</u> | <u>Page</u> | |
|--------------|--|-------|
| 4.5-1 | Typical Dial-Up Long Distance Rates | 4-136 |
| 4.5-2 | Incoming/Outgoing WATS Charges for Band 1 | 4-136 |
| 4.5-3 | Incoming/Outgoing WATS Charges for Band 2 | 4-137 |
| 4.5-4 | Pennsylvania Limited Coverage (East) TELCO Rates For Small and Large Business Services | 4-138 |
| 4.5-5 | Pennsylvania - Wide Coverage TELCO Rates for Small and Large Business Services | 4-138 |
| 4.5-6 | Call Charges for Leased Lines with Grade of Service = .05, at Various Distances (1982 AT&T Tariffs for A-B Cities) | 4-140 |
| 4.5-7 | Radio Relay Tower Costs | 4-140 |
| 4.5-8 | Computation of Radio Relay System Cost per Minute vs. Number of Trunks and vs. Distance | 4-144 |
| 4.5-9 | S-Band Link, SCPC | 4-148 |
| 4.5-10 | Cost Summary for Gateway Terminals | 4-151 |
| 4.6-1 | Frequencies and Multipliers For Frequency Tracking | 4-164 |
| 4.6-2 | Common Signalling Channel Characteristics | 4-172 |
| 4.6-3 | Range of Coverage Angles | 4-178 |
| 4.6-4 | Fixed Antenna Characteristics | 4-180 |
| 4.6-5 | Mobile Radio Characteristics | 4-202 |
| 4.7-1 | Investment Per Trunk and Investment Per Subscriber, Total Investment = \$1470M | 4-205 |
| 4.7-2 | Call Minute Charges | 4-205 |
| 4.7-3 | Monthly Charges for Typical Subscribers | 4-205 |
| 4.7-4 | Typical Gateway Charges | 4-206 |
| 4.7-5 | Equivalent Transceiver Charges | 4-206 |
| 4.7-6 | Typical Total Subscriber Charges (Space Segment, Gateway and Mobile Radio) | 4-208 |
| 4.8-1 | Cost Allocation, Concept C2 | 4-215 |
| 4.8-2 | NASA Investment Schedule, Scenario "A" | 4-216 |
| 4.8-3 | Commercial Investment Schedule Scenario "A" | 4-217 |
| 4.8-4 | NASA Investment Schedule, Scenario "B" | 4-218 |
| 4.8-5 | Commercial Investment Schedule, Scenario "B" | 4-219 |
| 4.8-6 | Space Segment Technology Assessment | 4-222 |

4.0 HYBRID (SATELLITE) SYSTEM

4.1 SATELLITE SYSTEM ARCHITECTURE

4.1 SATELLITE SYSTEM ARCHITECTURE

4.1.1 SYSTEM ELEMENTS

The Land Mobile Satellite System (LMSS) consists of three elements, space segment, gateway (fixed) terminals and mobile terminals. The space segment is further divided into satellite, launch vehicle, Network Operating Center (NOC), Satellite Operating Center (SOC) and various launching and on-orbit services. Mobile terminals consist of three generic types, a cellular-compatible mobile terminal, primarily for voice and voice bandwidth (data) dialup service, (compatible with both satellite and terrestrial), a "stand-alone" mobile terminal primarily for voice and voice bandwidth (data) dial-up service (not compatible with a terrestrial system) and a "stand-alone" fixed tuned mobile terminal, for interactive (low throughput but bursty) data for telemetry and control, and for position location. The purpose of the system architecture is to describe the characteristics and performance of these elements, and to define generic services, so that various cost characteristics such as investment, expense, return on investment and service charges can be computed in a later section.

4.1.2 LMSS UNIQUE FEATURES

The system architecture stresses the unique features of LMSS with respect to the terrestrial mobile system in order to enhance its value to prospective users. Of paramount importance is "ubiquity". In principle, LMSS can provide service everywhere since its antenna beam(s) cover the U.S. including offshore locations. LMSS has no range limitations like the terrestrial system and in an economic sense, is not limited to service areas, like terrestrial systems, having sufficiently dense populations. For economic viability, the satellite must serve a sufficiently large total population (in its coverage area) but local population densities are not important. In a practical sense however LMSS is not ubiquitous. If the satellite is obscured by a building, hill, bridge or foliated tree the LMSS signal is not usable. As a mobile penetrates urban areas, multipath caused by building reflections received in its antenna beamwidth and man made noise, particularly automobile ignition noise, also is encountered. Satellite elevation in Alaska also will be low resulting in significant multipath. As a result there are areas where the LMSS signal may not be usable. In some cases, an "aware" driver can correct the problem by either waiting until a more favorable situation occurs (he moves out from behind an obstacle), or taking some specific action ("pause" at a place where

multipath permits communication). An important approach taken in this study is to identify mobile antenna concepts that maximize ubiquity. This entails use of antennas having low gain in the lower hemisphere but high gain in the satellite direction, and good circular polarization purity. If modulation also is selected that tolerates significant (fade) degradation then the LMSS ubiquity is, in the fullest sense, preserved except for quite rare occurrences. Experience with experimental LMSS bears this out.

High communications performance also is provided because significant multipath is seldom encountered, and the coherent bandwidth exceeds the probable spectrum allocation. Wideband data signals are easily transmitted without special precautions (terrestrial systems in the presence of Rayleigh fading require repeat transmission to recover lost bits).

Satellite services are flexible if the satellite is not channelized and a common signalling channel and centralized control (via the NOC) is available to allocate bandwidth and power on demand. In particular, high speed data such as 56 KBPS or higher is easily accomplished and can be provided on demand, (some precautions are necessary to group compatible signal formats in order to minimize the effects of intermodulation noise).

Adaptation of these features in the system architecture will demonstrate that LMSS has a competitive cost vis-a-vis terrestrial mobile services, is particularly competitive over long (long distance) routes, such as is encountered in the transportation industry, and that LMSS can have sufficient capacity to be an important adjunct to the terrestrial service so as to justify the spectrum allocated to it.

Finally, a last important point is that LMSS complements the terrestrial mobile system, particularly those in the 806-890 MHz band by providing services not economic or practical by terrestrial means, e.g. service in rural and suburban areas, wideband services, long distance services and special position location services. On the other hand, LMSS can not replace or compete with terrestrial systems in urban areas because LMSS can not develop the necessary capacity (by cell division). Therefore the satellite and terrestrial services are truly complementary - with terrestrial systems primarily serving the high capacity urban areas and LMSS primarily serving elsewhere.

4.1.3 LMSS SERVICES

It is convenient to define three LMSS service groupings. The first of these is radio telephone, essentially extending the services projected to be provided by the terrestrial, cellular systems, such as AT&T's "AMPS". In this case, LMSS can provide service to extra-cellular roamers, wideband data services (which might otherwise be degraded by the Rayleigh fading encountered in cellular systems), paging (to help locate roamers), and long distance services. In the latter case it may be more cost effective to route long distance calls via LMSS than via the available TELCO. There is also the possibility for a "stand-alone" radio telephone service, optimized for satellite use and not compatible with the cellular system equipment and parameters. While the operator may be local, the service is national because of ubiquity.

The second service is an extension of the Special Mobile Radio (SMR) services consisting of government, business, special industry, police, firefighters etc. These are principally private dispatch networks with no requirements for connectivity to the TELCO or to each other. LMSS can provide some of these services, particularly those requiring extended ranges or wideband data or position location services.

The third service, interactive data and position location, is a new service not now provided, to both the transportation industry (trucking, railroading, intracoastal shipping) and to the prospecting industry (oil well logging, mining, etc.), and others.

These three services make use of the following generic communications:

1. Dialup voice
2. Dialup voice bandwidths (wideband data)
3. Interactive data (low throughput, bursty)
4. Position location

Voice may be FM or SSB. Data is likely to be CPSK to conserve satellite bandwidth and power. Interactive data is typified by a transceiver which has a telemetry or control capability. For example, the transceiver may be

monitoring the status of a truck trailer, utility line, etc. with a block of 250 bits.

Periodically, typically several times a day, the transceiver can be interrogated by the NOC, (e.g. triggered to transmit its 250 bit block of data for processing) or it can transmit spontaneously for certain "alarm" situations (excessive temperature, unauthorized entry, etc.). Similarly, control of local devices (such as utility switches) can be exercised remotely. In addition, the location of the transceiver can be determined to within typically a tenth of a mile providing routing control of trucks, trains, buses etc. All in all, users can make use of any of these services individually or several in combination. For clarity, the service definitions and costs are evaluated individually.

4.1.4 REQUIREMENTS AND CRITICAL PARAMETERS

4.1.4.1 General Requirements

General LMSS requirements define important characteristics and goals. Thus, LMSS should be flexible with regard to service mix, service capacity and allocation of bandwidth and power, on demand. The common signalling channel and centralized control via the NOC are important to the realization of this goal, as is an unchannelized satellite. Service quality is dependent on user expectations. Radio telephone subscribers (the public) generally require higher quality service than, for example, industry dispatch users who emphasize intelligibility. However "toll quality" telephone is not provided by terrestrial radio telephone service because of Rayleigh fading and co-channel and adjacent channel interference. Therefore it is not necessary to provide this by LMSS unless it can be done at costs which are competitively priced. Grade of service objectives for cellular systems are in the range of .01 to .05, and similar criteria is proposed for LMSS. It should be noted that the actual grade of service attained depends principally on the gateway terminal equipment. It is expected that the gateway will have relatively few MODEMS and smaller operators will accept higher grades of service to achieve gateway economy even though the mobile and satellite are capable of better service.

The LMSS described herein provides full U.S. coverage including offshore locations; where important, design choices required for full coverage including offshore, are indicated, however detailed conceptual designs for these cases are not provided. Compatibility with radio telephone terrestrial systems, so that subscribers can use either terrestrial cellular or satellite is an important consideration. Existing terrestrial cellular mobile designs are optimized for that service, considering the peculiarities of terrestrial systems, e.g. the presence of multipath, co-channel and adjacent channel interference, and geographically small cells. Utilization of that design for LMSS results in unacceptably poor performance. Optimization of the mobile design for satellite use radically alters the existing design. Perhaps ultimately, the mobile design could embrace reasonably optimized performance for both terrestrial and satellite systems however, for the present study the cellular compatible design represents a minimum cellular system modification, sufficient to provide good performance with LMSS. The "stand-alone" mobile transceiver is an example of satellite system optimization (spectrum efficiency, positive network control etc.). With the definition of service provided above, only the radio telephone service needs to be terrestrial compatible.

In conclusion, it appears quite practical, and desirable that LMSS be able to accommodate an arbitrary mix of services, by allocating power and bandwidth on demand, and utilize a centralized network control with a continuously available common signalling channel (except for the cellular compatible service where this is not possible).

In this system mobile communications are provided at UHF between the mobiles and the satellite, and fixed communications provided at S-Band (Ku-Band also is considered) between the gateways and the satellite. Mobile to mobile communications are not normally desired but can be double-hopped via a patched gateway. Satellites using on-board routing and switching also enable mobile-mobile communications.

Full satellite subsystem redundancy is necessary. Since two satellites for position location services are needed, two satellites, orthogonally polarized and with interstitial frequency plans are defined as an operating system, with a third non-operating satellite as a spare. Mobile equipment redundancy is not required. Gateway redundancy also is not required because a neighboring

gateway plus the TELCO can be used as a "work around" in case of local gateway failure. This reduces gateway costs and encourages widespread gateway deployment which enhances system flexibility. Of course some "hub" gateways carrying heavy or vital traffic will be fully redundant.

The technology assumed is that believed to be readily achievable in the 1990-2000 time frame. In particular, a large multibeam deployable antenna is assumed to be adequately developed, and its spacecraft impact sufficiently understood to enable commercial implementation in this time frame. Other technologies such as low noise transistors and efficient linearized solid state power amplifiers exhibit performance which is based on prudent projections of current developments.

Since one ultimate purpose is to compare in cost a (nearly) ubiquitous terrestrial system and a LMSS, an attempt is made to use cost yardsticks which are valid for the comparison. Assumptions with regard to interest rates, returns on investment etc. should use common methodology. However, annual charge, investment per subscriber, investment per erlang are methods which are expected to shed light on the cost differences between the two systems.

4.1.4.2 Particular Requirements

The study considers only geosynchronous satellites. Mobile communications are in the 806-890 MHz band, (allocated by the 1979 WARC). Fixed bands are assumed to be in S-Band (2500-2690 MHz band), however some consideration also is given to use of C-Band (6/4 GHz), Ku-Band (14/12 GHz) and Ka-Band (30/20 GHz).

Multipath, caused principally by ground skip, and reflections from nearby objects such as buildings, man made noise, and shadowing are occasionally encountered in rural and suburban areas and margin is used to combat the effects. However, like the telephone system, fading in LMSS is defined as a degradation from some nominal performance level, including the possibility of fading to a useless signal level. While there is no available data that can mathematically define performance in these circumstances, a significant part of the mobile conceptual design effort is to identify the mobile antenna types that will be most resistant to these effects. Unlike the terrestrial system where the reflected and direct signals arrive at the mobile (and base) at

virtually the same angles and where the links are substantially "over powered" in order to "swamp" man made noise (and effects of Rayleigh fading), the satellite system can discriminate against both noise and reflections. High spectrum efficiency can be attained in a "spectrum starved" LMSS by using the orthogonal polarization (imposing additional design requirements on the mobile antennas), and by using spectrum efficient FM and single sideband. Use of compandors for both FM and SSB not only improves performance but increases the resistance to co-channel interference, enhancing the performance of the dual polarized system.

The full time common signalling channel assures maximum utilization of each "trunk", and positive network control, as explained previously. Other uses are as a frequency standard to avoid the use of an expensive oven controlled crystal oscillator in the mobile, as a pilot signal to enable mobile antenna steering if needed and as a method to control mobile and gateway amplifier levels. The latter enables constant satellite eirp per carrier regardless of the mobile's position in the satellite antenna's field-of-view, dynamic allocation of power for different services, and the availability of a dynamic power margin, on demand. The NOC via the common signalling channel also pages mobiles, and the NOC records the beam location of mobiles, as they traverse the satellite beams (for later paging).

4.1.4.3 Critical Parameters

Critical parameters affecting LMSS performance and cost are summarized in the following:

Spectrum Efficiency

1. Frequency reuse via multiple spot beams
2. Frequency reuse via orthogonal polarization
3. Spectrum efficient, compandored FM and SSB (where applicable), and LPC
4. Time division (TDM plus slotted ALOHA) for interactive data channels and common signalling channels
5. Interstitial spacing to provide additional isolation in an interference environment

Power Efficiency

1. Linearized, class AB satellite amplifiers
2. High gain mobile vehicle antennas
3. Companded voice
4. Fade to usable signal
5. Power diversity

Weight Efficiency

1. Multi frequency antennas (UHF and S-band)
2. Solid state power amplifiers
3. Projected state of the art in satellite bus technology

Flexibility

1. Low cost gateways
2. Common signalling channel and centralized network control

4.1.5 FREQUENCY PLANS

LMSS operations should be in the band 806-890 MHz, allocated by the 1979 WARC (ITU). In the U.S., this is a new band allocated to cellular radio telephone, Safety and Special Mobile Radio (SMR) and 14 MHz of reserve bands. LMSS serves both cellular radio telephone and SMR. A NASA proposal to the FCC recommends a reallocation of the 806-890 MHz bands preserving the total spectrum already allocated to cellular and SMR, but rearranging this spectrum so as to provide two 10 MHz allocations out of the reserve bands for LMSS between the cellular and SMR allocations. The plan is attractive to LMSS because the bands are contiguous, common mobile equipment can be used, and therefore all services benefit from the resultant mass production. The existing plan and NASA plan are depicted in Figure 4.1-1. The NASA plan is adopted for this study, resulting in the 821-831 MHz band allocated to satellite uplinks and 866-876 MHz band allocated to satellite downlinks. In addition, for fixed link, the band 2500-2690 MHz is believed to be available on a shared basis, however, C-Band (6/4 GHz) Ku-Band (14/12 GHz) and Ka-Band (30/20 GHz) also could be used.

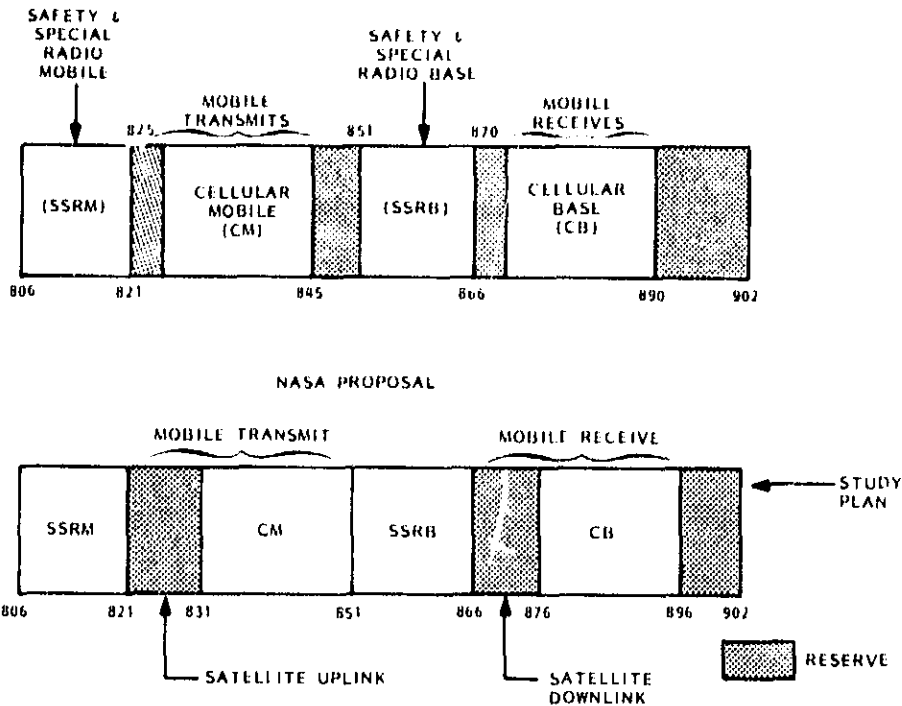

Figure 4.1-1. Current FCC Frequency Allocation and NASA Proposed Revision

4.1.6 GEOMETRIC FACTORS

4.1.6.1 Satellite Orbital Locations

Satellite orbital locations are based on a two satellite system, separated by nominally 30 degrees, (for position location services), and on consideration for coverage of CONUS, Alaska, Hawaii and Puerto Rico. Such a configuration is advantageous because a spare satellite is one of three satellites, sparing is thus 3/2 and the cost of sparing is less, compared to a 1/1 situation. Most networks utilizing LMSS are private and little interconnection, if any at all, is required between them. Consequently, CONUS networks can be served on either satellite, and the most favorable satellite can be selected in most cases.

If the pair of satellites is too far east Alaska service suffers; if too far west, CONUS coverage by the western satellite suffers. Recognizing that the dominant service will be to CONUS, orbital positions around 90°W and 120°W

are nearly optimal. Table 4.1-1 lists coordinates examined and the resultant approximate elevation angles to the satellite, and relative slant range to the local vertical.

The common signalling channel can be used to control power amplifiers such that a uniform carrier flux density is obtained, considering both satellite antenna gain variations and slant range differences, and possible mobile antenna gain differences because of terrain slope.

Table 4.1-1. Geometric Factors for CONUS and Offshore

| LOCATION | COORDINATES | SATELLITE ELEVATION | | |
|-------------|-------------|---------------------|----------------------------|-----------------|
| | | 90°W | 120°W | |
| CONUS { | MAINE | 70°W, 45°N | 34.5° (0.55 dB) | 18.8° (0.89 dB) |
| | TEXAS | 98°W, 27°N | 57° (0.2 dB) | 50.3° (0.3 dB) |
| | SEATTLE | 123°W, 43°N | 30.4° (0.65 dB) | 40.3° (0.45 dB) |
| ALASKA | 165°W, 70°N | NOT FULLY COVERED | 6°-19.9° (1.15-0.88 dB) | |
| HAWAII | 155°W, 20°N | 15.2 (0.95 dB) | 44° (0.38 dB) | |
| PUERTO RICO | 65°W, 18°N | 54.6° (0.22 dB) | 25.3° (0.74 dB) | |

Good service to Hawaii and Puerto Rico is provided in this arrangement. Alaskan service using the western satellite is feasible although, like the terrestrial system, multipath will be encountered. Position location also is possible for the more inhabited areas of Alaska which can view both satellites. In this situation however multipath will be a problem. For important communications, vehicles may have to pause at places of good signal strength (in this case the signal strength will slowly fluctuate-due to the multipath-because the satellite is slowly drifting).

4.1.6.2 Differential Range

The interactive data system (telemetry and control and position location) is a query and response, packet-switched system controlled by the NOC. The NOC composes an outgoing TDM message train consisting of various addresses of transceivers. Each transceiver responds only to its own address, by transmitting its encoded information or transponding a "position fix". Except for equipment response times the incoming data stream also is TDM. However, guard times have to be allowed to account for the different message transmission times for transceivers at different ranges from the satellite. These guard times are a function of the number of beams, e.g. the geographical extent of the beam, and are listed in Table 4.1-2, along with the worst-case impact to a 6KBS data channel having 250 bit blocks. The efficiency improves with the number of beams because the "guard" time is reduced. This represents a maximum inefficiency because the NOC can "learn" the differential delay associated with each transceiver, and, if the query message is shorter than the response message, (which it ought to be), can adjust the query time to reduce the guard time. Some caution must be exercised since the transceiver (mobile) may be moving. Thus the efficiency is essentially efficient TDM in both directions, and the differential delay, at 6KBPS rates is not important. It should be noted that other requirements reduce transmission utilization. One is a periodic pause in the NOC outgoing query stream (signalled by an alarm "enable"), to allow for "spontaneous" alarms (signalling intrusion or some other crisis state). The "pause" is long enough so that randomly timed bursts from various mobile transceivers in an alarm status can convey the alarms back to the NOC without collision. Another reduction in transmission utilization is the communication from the NOC to the operator, updating the status of their mobile transceivers. Since the data is processed, e.g. only changes and alarms are sent, the requirement for transmission capacity should be relatively small.

Table 4.1-2. Packet Guard Time Uncertainty

| NUMBER OF BEAMS | BEAMWIDTH | T (ONE WAY UNCERTAINTY) MS | EFFICIENCY * % |
|-----------------|-----------|----------------------------|----------------|
| 97 | 0.41° | 0.8 P-P | 96 |
| 12 | 1.5° | 2.9 | 88 |
| 1 | 6° X 4° | 5.9 | 78 |

* ESTIMATE FOR 250 BIT BLOCK AT 6 KBPS

4.1.7 STRATEGY FOR SATELLITE CONCEPTS

4.1.7.1 Introduction

The satellite concepts for the system architecture must be consistent with the gateway and mobile equipment defined previously, must be defined by a consistent set of parameters, and must be consistent with the various traffic/capacity/services concepts evolved in the Study. Several satellite models are defined, which are to be examined parametrically with regard to the impact on subscriber charges. Each satellite concept will be defined by:

1. Antenna beam and frequency plan
2. Transponder configuration
3. Routing, accessing and switching definition
4. Signalling arrangement and Network Control
5. Physical characteristics (primarily weight and power).

It is planned to compute the weight and power of each satellite concept parametrically with regard to satellite eirp in order to assess the impact of power to satellite weight, prime power, and cost.

4.1.7.2 Satellite Capacity

Five generic satellite concepts are evaluated; these are listed in Figure 4.1-2. The first four concepts, A, B, C, and D are planned to be used in various ways in the parametric cost tradeoffs. Concept D', a hundred beam satellite like D, makes use of a single Ku-Band beam for its fixed link as

compared to D which requires multiple S-Band beams and on-board switching. In these arrangements each satellite makes use of the entire available band, e.g. a one beam satellite has a bandwidth of approximately 10 MHz (the full allocation) and multiple beam satellites, using a 4:1 segmentation scheme, have a bandwidth per beam of approximately 2.5 MHz. Thus, the two operating satellites are co-channel but orthogonal in polarization.

4.1.7.3 Link Performance

Performance levels are defined parametrically in order to permit evaluation of the cost sensitivity to various system parameters. For example, mobile operation in rural areas with flat terrain will experience almost ideal, (free space) propagation conditions. There will be some small amount of multipath from ground reflections, occasional shadowing from a foliated tree, hill etc. and perhaps occasional ignition noise from passing vehicles. As the mobile penetrates suburban and then urban areas, sporadic shadowing, multipath from obstacles such as buildings, and more man-made noise will be encountered. Finally, in center city the satellite may be completely shadowed by tall buildings. The ability of the mobile to function in this environment is

| CONFIGURATION | A | B | C | D | D' |
|---|-----------|-------------|---------------|----------------|----------------|
| NUMBER OF UHF BEAMS | 1 | 12 | 31 | 100 | 100 |
| UHF BEAMWIDTH * | 6° X 4° | 1.5° | 0.77° | 0.41° | 0.41° |
| NUMBER OF FIXED SERVICE BEAMS | 1 (S) | 1 (S) | 1 (S) | 15 (S) | 1 (Ku) |
| ON BOARD SWITCHING | NO | NO | NO | YES | NO |
| SYSTEM CAPACITY** (MHz) (DUAL POLARIZATION) | 20 | 60 | 155 | 500 | 500 |
| EQUIVALENT FM/SSB TRUNKS*** | 1333/5000 | 4000/15,000 | 10,333/38,750 | 33,333/125,000 | 33,333/125,000 |
| POWER, KW | 0.6-2.0 | 0.5-1.0 | 0.7-1.8 | 9.0-9.8 | 2.6-3.4 |
| WEIGHT, KILOPOUNDS | 0.6-2.0 | 1.8-2.0 | 3.4-3.8 | 16.6-17.0 | 12.3-12.5 |

* SEGMENTATION 4:1

** 2 SATELLITES

*** CFM IS 15 KHz, CSSB IS 4 KHz

Figure 4.1-2. Satellite Configuration Summary

related to the link margins, the intelligibility of the modulation under faded conditions, and on the ability of the mobile antenna to suppress obstacle multipath and man-made noise. The subscriber also will learn to adapt to local conditions - he can certainly take action against being shadowed, and obstacle multipath and man made noise are purely local effects which will differ in different locations. The satellite system, by adaptively providing more link power (for both uplink and downlink), via the centralized Network Operating Center also can provide an adaptive response to excess noise or interference situations. Finally, the performance of LMSS ought to be measured against terrestrial mobile radio performance which is plagued by co-channel and adjacent channel interference and Rayleigh fading e.g. it is not necessary and probably not desired by the subscriber to achieve toll quality performance for LMSS.

Since standards for LMSS are clearly lacking and experience with LMSS links is almost totally lacking, the approach taken in the study is to describe the power performance and cost parametrically.

Performance for compandored FM links is based on a 13.5 KHz noise bandwidth, 15 KHz center-to-center, and quiescent CNR = 14.8 dB, which provides 5 dB margin against threshold (7 dB with threshold extension). Signal to noise density required is 56.1 dB-Hz.

Performance for compandored SSB links is based on 3400 Hz noise bandwidth, 4 KHz center-to-center spacing, and a quiescent CNR = 15 dB. Signal to noise density requires 50.3 dB-Hz. Note that the ratio of the two signal to noise densities, and the bandwidth ratio, is 5.7 dB. With the two signals defined in this way the satellite available power can be used to provide 15 KHz FM signals or 4 KHz SSB signals interchangeably, for the purpose of computing numbers of 15 KHz or 4 KHz channels, (the same is true for 30 KHz FM).

The nominal C/I ratio due to satellite non-linearity is assumed to be 23 dB. For a given satellite power this establishes a "floor" in noise performance which particularly affects SSB which does not have the processing gain of FM e.g. compandoring and pre-emphasis are the only way SSB can achieve toll-like quality in an interference environment.

Note also that SSB power is average power; mobile power amplifier capability must be increased by at least 6 dB to handle envelope peaks. The linearized satellite amplifier operating under multicarrier operating conditions automatically provides the peak power capability.

The approach to performance definition defines a nominal "best" case link situation at UHF and at S-Band; this is listed in Figure 4.1-3. The UHF downlink to the mobile, at an average frequency of 871 MHz is based on a high gain mobile antenna and a GaAsFet low noise receiver. To achieve this performance at least part of the low noise amplifier must be located at the antenna, possibly preceding the receiver band pass filter. The GaAsFet technology is probably achievable by the mid 1980's. Allowances for intermodulation and antenna side lobe interference noise and uplink thermal noise are included. Fading, when and if encountered, (due to multipath, man made noise, or interference) causes a reduction in signal quality. A similar approach is adapted for the UHF mobile uplink. The S-Band downlink is based on a 3 meter gateway antenna and this link contributes the bulk of the thermal noise. While assumed for the study, this arrangement is not necessarily optimum for LMSS since it increases the mobile's power amplifier requirements. The links also can be arranged so that the mobile to satellite link noise is dominant, thus reducing the mobile power amplifier requirements.

In the satellite system weight and power analysis the power will be increased in two 5 dB steps to account for lower gain mobile antennas, added fade margins, or other changes in system parameters.

| | SATELLITE TO MOBILE | GATEWAY TO SATELLITE | SATELLITE TO GATEWAY | MOBILE TO SATELLITE |
|--|------------------------|-------------------------|-------------------------|------------------------|
| | DL | UL | DL | UL |
| FREQUENCY (REFERENCE), MHz | 871 | 2650 | 2580 | 826 |
| EIRP PER CARRIER, dBw | +23.9 | +29.8 | +8.2 | +24.1 |
| SPREADING LOSS (LOCAL VERTICAL) dB | 182.4 | 192.0 | 191.8 | 181.9 |
| NOMINAL GEOMETRIC FACTOR, dB | -0.5 | 0.5 | 0.5 | 0.5 |
| MISC. PROPAGATION FACTORS, [*] dB | 0.1 | -0.1 | 0.1 | 0.1 |
| ANTENNA GAIN, USEFUL, dBi | +10.0 (YAGI) | +28 (CONUS) | +35.8 (3M) | +23.2 |
| RECEIVED SIGNAL LEVEL, dBw | -149.1 | -134.8 | -148.4 | -135.2 |
| NOMINAL SYSTEM NOISE TEMP**, dB -K | +22.0 (160K) | +26.5 (448K) | +22.7 (186K) | 25.9 (391K) |
| G/T dB/K | 12.0 | +1.5 | +14.7 | +2.1 |
| CN ₀ dB Hz | 57.6 | 67.3 | 57.5 | 67.5 |
| INTERMOD, INTERFERENCE ALLOWANCE, dB | -1.0 | | -1.0 | |
| UPLINK THERMAL NOISE ALLOWANCE, dB | -0.4 | | -0.4 | |
| TOTAL CN ₀ , dB Hz | 56.2 | | 56.1 | |

^{*} NOT INCLUDING MULTIPATH FADING DO TO BUILDING/TERRAIN SKIP, AND MAN MADE NOISE

** 1 dB, 0.4 dB LOSS, 52°K ANTENNA NOISE

Figure 4.1-3. Nominal Performance Levels

4.2 SATELLITE CONCEPTS

4.2.1 SATELLITE CONCEPT "A"

4.2.1.1 Frequency Plan, Beam Plan and Capacity

Concept "A" is a small, low capacity LMSS based on 1982 technology. Concept A frequency plan is depicted in Figure 4.2-1 based on the assumed NASA plan. Transmit and receive frequencies at UHF and at S-Band differ by 45 MHz, as in the cellular or SR bands. Anticipating the 4:1 segmentation and associated signalling requirements, the common signalling channels, one for mobile-NOC, one for gateway-NOC are located at the band centers of the segmented bands. Only one of the four possibilities is used in the single beam satellite. Either polarization set may be selected for satellite use.

A 10' satellite UHF aperture is assumed, with coverage as depicted in Figures 4.2-2 and 4.2-3 for $90^{\circ}W$ and $120^{\circ}W$ respectively, covering the U.S.; the 10' UHF antenna 3 dB coverage exceeds the dimensions of CONUS. An additional feed is added to show, as an example, how Hawaii (and Alaska, and Puerto Rico) might be served by the single beam satellite. A "shoulder", at a level approximately -6 dB from the CONUS peak illuminates Hawaii. The design is accomplished with an $F/D = 1.0$, using lightweight short helix or crossed yagi feeds. Two feeds are required. CONUS lies inside the -2dB contour while, Hawaii lies on the -5.8 dB contour provided by the satellite at $90^{\circ}W$. Similar results are obtained by the satellite at $120^{\circ}W$, however, Alaska coverage is inside the -3dB contour. Since Hawaii capacity relative to CONUS is small, and Hawaii mobiles can use higher gain antennas because the elevation angles encompassing the satellites are much smaller, the impact on satellite power can be neglected. The capacity of each satellite, considering that the full 10 MHz bandwidth is available is 667 15 KHz trunks or 2500 4 KHz trunks.

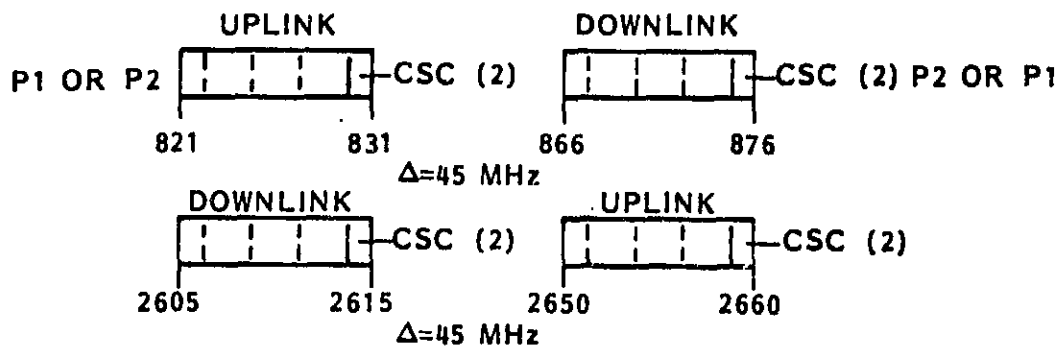

Figure 4.2-1. Concept A Frequency Plan

C

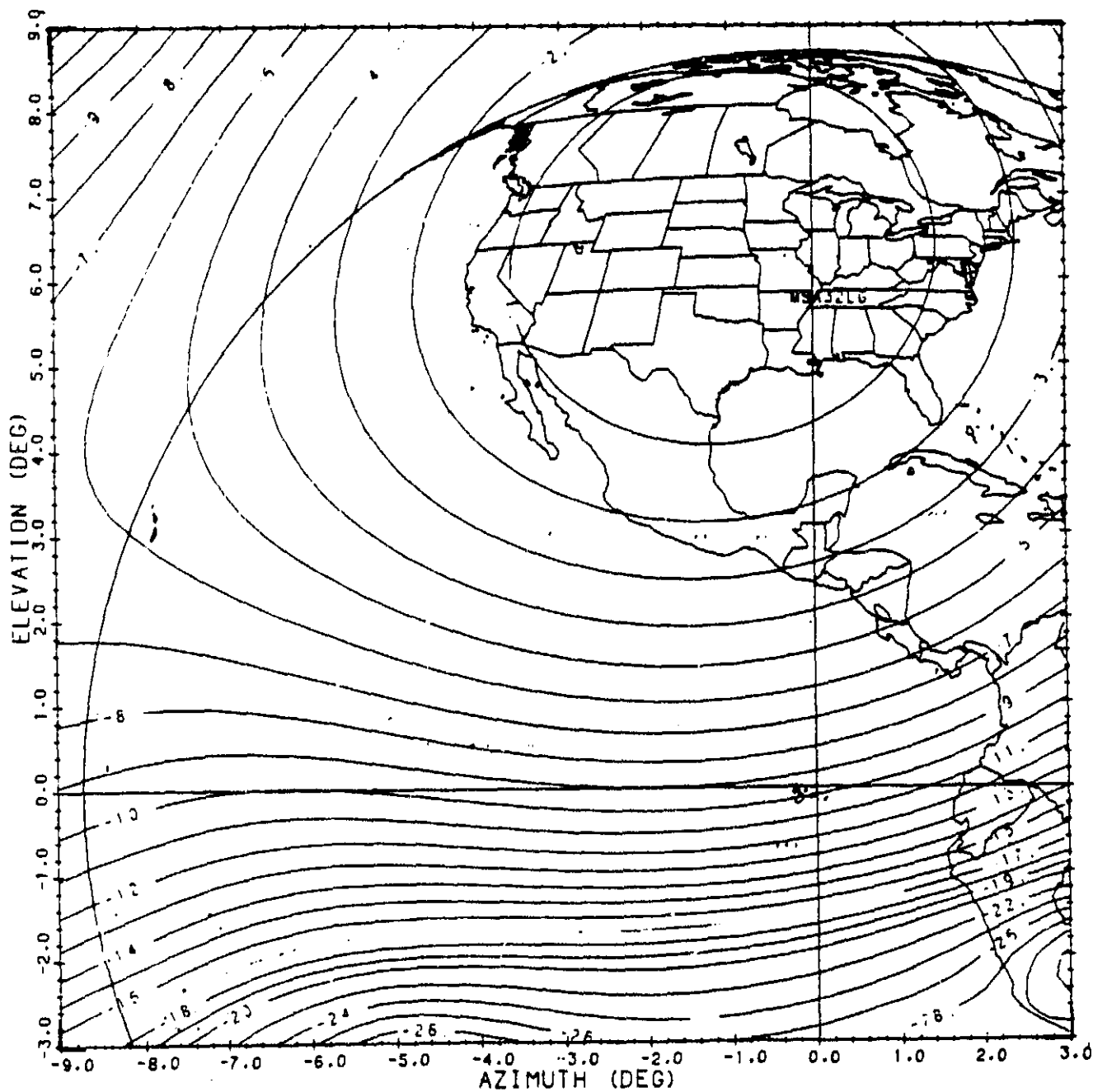

Figure 4.2-2. Satellite Antenna Beam Coverage of U.S. from 90°W

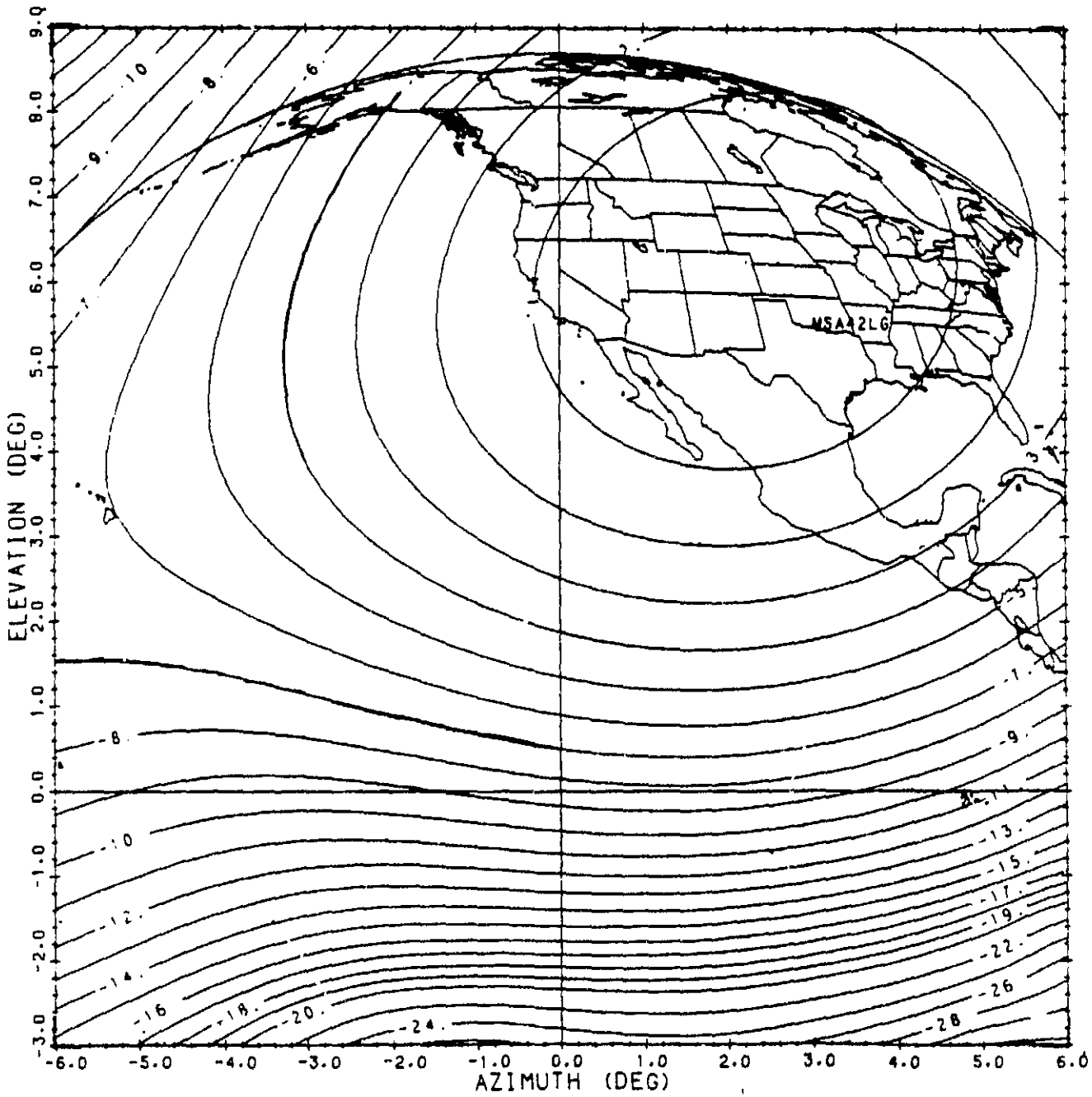

Figure 4.2-3. Satellite Antenna Beam Coverage of U.S. from 120°W

ORIGINAL PAGE IS
OF POOR QUALITY

4.2.1.2 Transponder Arrangement

The transponder arrangement in Figure 4.2-4 depicts the principle components. The power amplifiers are linearized, probably class AB, bipolar transistors, and the low noise amplifiers use GaAsFet's. A single (operating) LO is needed for the specified frequency plan. It is likely that the LO frequency will be ground controlled. Variable attenuators compensate for gain drifts. Filtering is a particularly difficult problem for an LMSS because of the small frequency separation between the transmit and receive bands both at UHF and S-Band, (but not at Ku-Band). Two problems are particularly severe. One is to attenuate the transmitter signals leaking into the receiver so that the receiver circuits do not saturate. The other is to filter the intermodulation products, generated in the transmitter by the transmitter non-linearities, so that these do not interfere with the operation of the receiver (desensitize the receiver).

While a detailed analysis was not performed it appears that adequate rejection of spurious can be obtained by a 4 pole transmitter output bandpass filter, in conjunction with a receiver band "notch" or band stop filter, attenuating receiver intermodulation products by about 50 dB, (additional isolation is provided by the UMT/antenna). The receiver filter can consist of a 6 pole filter as a preselector or, to improve sensitivity, part of this filter can be located in later stages of the LNR. The filters have stringent design requirements and contribute significantly to satellite payload weight, particularly to the multibeam payloads.

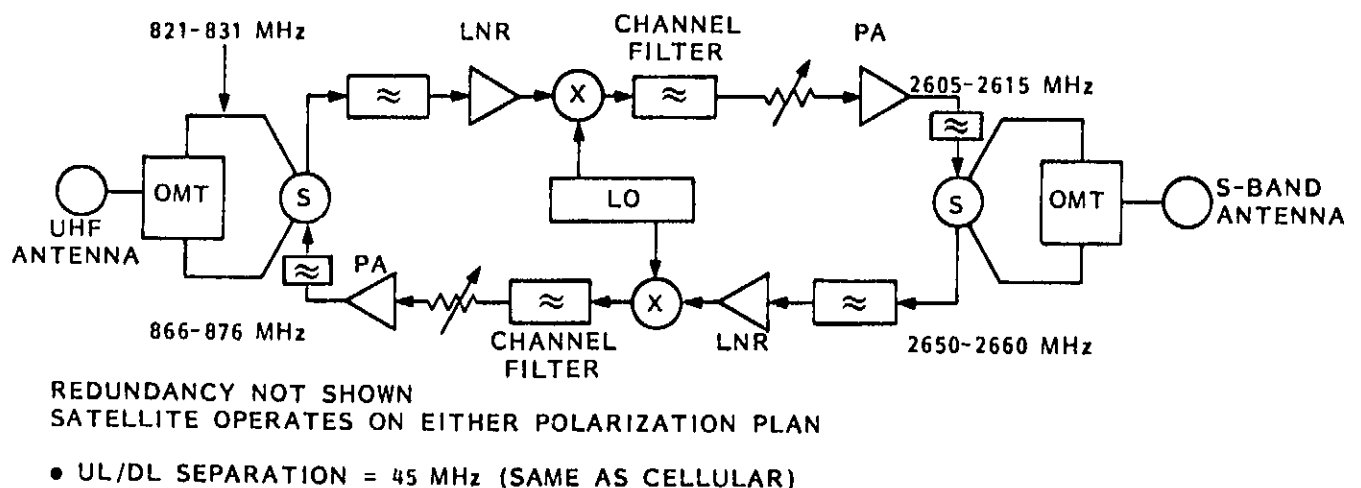

Figure 4.2-4. Concept A Transponder Arrangement

In addition, a receiver filter is needed to reject general out-of-band interference. A channel filter also is needed. Mobiles transmitting to terrestrial systems operate in bands surrounding the satellite UHF uplink, and generate typical carrier eirps in the satellite direction which are at least 5 dB below the satellite uplink carriers. Consequently, satellite receiver "saturation" is not a problem, however satellite filtering is needed (receive bandpass filter and channel filter) to prevent re-radiation of a significant level of these extraneous carriers in order to conserve satellite power. The re-radiated terrestrial carriers do not interfere with terrestrial system operation. Base station radiation towards the satellite is even larger, however the frequency separation from the satellite receive band permits adequate rejection of these extraneous signals. It should be noted that the principle interference problem in LMSS is the radiation of extraneous intermodulation (out-of-band) products by terrestrial base stations into the LMSS mobile receive band. Unless regulations are changed (requiring suppression of these interferences), the channel "choices" of LMSS mobiles operating near SRM or cellular base stations can be severely curtailed (reversing the uplink and downlink satellite bands eliminates this problem). Transponder gain also is large (inherent in a mobile system) and care will be needed to provide good shielding and to avoid passive intermodulation effects.

Transmitter efficiency at UHF is assumed to be 35% based on Class AB operation which appears to result in intermodulation (C/I) in the 20-25 dB range. This assumption is based on an industry survey of manufacturers which however indicated a substantial spread in expectations.

GE developed a Class C bipolar design *achieving efficiency in the range of 50-60% at 260 MHz at a 100 watt level with C/I (predicted and measured) of -20 dB. This is probably marginal with regard to C/I, and of course lower efficiencies will be obtained at 800 MHz. A new bipolar amplifier for INMARSAT (spacecraft procurement in 1983) resulted in an efficiency of 28% using 9 watt modules (50-100 watts total), with a C/I = -21 dB, American manufacturers predict 30-50 watts per device and efficiencies in the range of 35 to 45% for C/I = 20 dB or better, based on existing transistors.

* GE Technical Information Series No. 72SD266 - "Advanced UHF Spacecraft Transponder Development".

4.2.1.3 Signalling and Switching and Network Control

The basic access method assumed for the study is single channel per carrier (SCPC), or FDMA, with individual channels assigned on demand by a centralized Network Operation Center (NOC). Conventional telephone signalling is assumed. In a single beam satellite system the signalling and access is greatly simplified because all gateways and all mobiles and the NOC share the same band of frequencies and the same satellite beam.

Positive NOC control is provided, and capacity requirements for common signalling channels are reduced if the signalling is only between the NOC and gateways and between the NOC and mobiles (e.g. no gateway-mobile signalling). Then, the outgoing NOC messages are efficient TDM on dedicated channels. The incoming NOC messages from gateways and mobiles are contention access "slotted ALOHA", however, mobiles contend only with mobiles and gateways contend only with gateways. In a practical system the channel slots surrounding the signalling channel(s), and co-channel orthogonally polarized channel slots will probably be left vacant to avoid interference to signalling.

In this arrangement the NOC has access to both UHF (signalling to gateways) and S-Band (signalling to mobiles), required because the single beam satellite has only UHF/S-Band frequency translation. Alternatively (as is required for multibeam operation), the NOC can signal only at S-Band, and the gateways can be equipped for both S-Band and UHF operation. Of course, the NOC operates with both satellites, as do some gateways. Figure 4.2-5 depicts the signalling arrangement, frequency and routing plan.

Table 4.2-1 is an estimate of signalling channel bits for the four signalling paths. The address may be individual or that of a "fleet". Bits are included for controlling mobile and gateway power amplifier levels, identifying power and bandwidth requests; special standard messages (for example, a priority claim or notice of defective equipment), and, for gateways, a 20 bit earth station status message. Twelve bits are included in outgoing NOC messages to identify 4096 channel slots (10 MHz divided by 4 KHz is 2500 maximum slots).

Note that both FM and SSB have provisions for in-band signalling. In a practical system the outgoing signalling channel will likely have a high CNR. However use of BPSK, rate 3/4 convolutional coding with hard decision, is

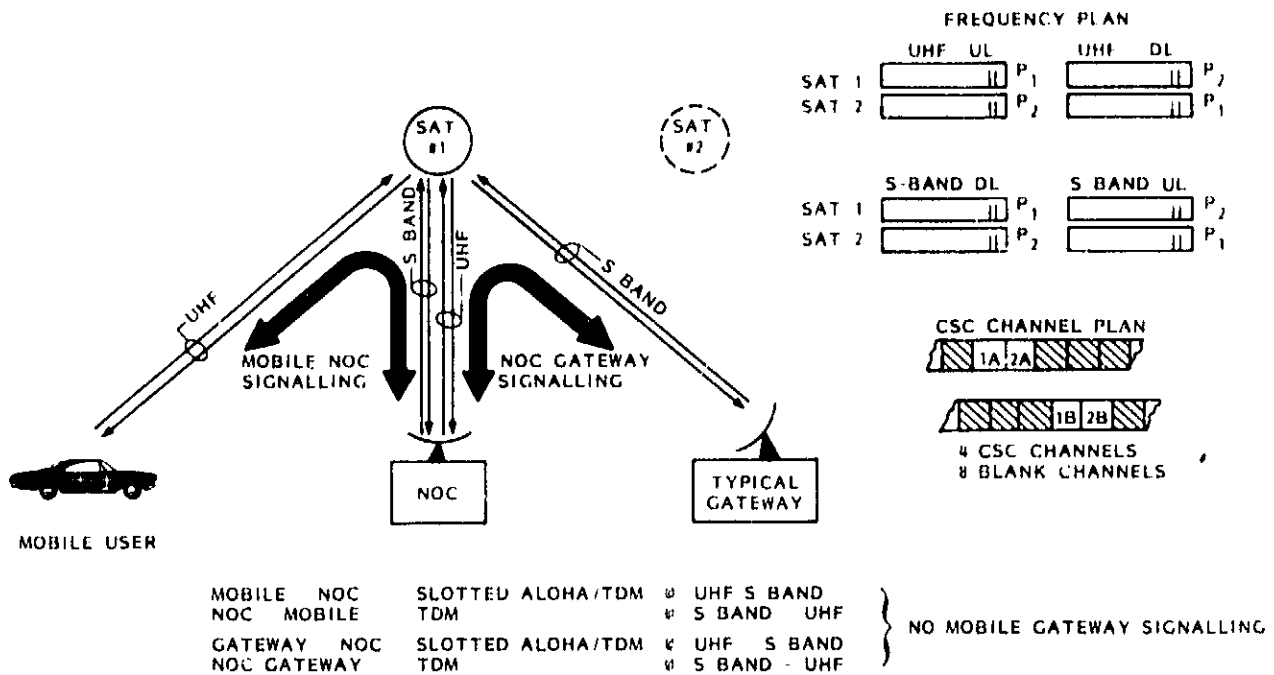

Figure 4.2-5. Concept A Common Signalling Channel Arrangement

Table 4.2-1. Concept A Common Signalling Channel Requirements, Voice

| | MOBILE-NOC | NOC-MOBILE | GATEWAY-NOC | NOC-GATEWAY |
|---------------------------|------------|---------------|-------------|---------------|
| ID | 34 | -- | 34 | -- |
| ADDRESS | 34 | 34 | 34 | 12 |
| CARRIER LEVEL | 3 (CSC) | 3 (HPA LEVEL) | 3 (CSC) | 3 (HPA LEVEL) |
| POWER/BANDWIDTH NEEDED | 2 | - | 2 | - |
| CHANNEL SELECTION | - | 12 (4096 MAX) | - | 12 |
| STATUS | - | - | 20 | - |
| SPECIAL STANDARD MESSAGES | 3 * | 3 ** | 3 * | 3 ** |
| SYNC | <u>20</u> | <u>20</u> | <u>20</u> | <u>20</u> |
| SUBTOTAL | 96 | 72 | 116 | 50 |
| CODING (RATE 3/4) | <u>32</u> | <u>24</u> | <u>39</u> | <u>17</u> |
| TOTAL | 128 BITS | 96 BITS | 155 BITS | 67 BITS |

* EXAMPLE - PRIORITY MESSAGE, ETC

** EXAMPLE - YOU HAVE DEFECTIVE EQUIPMENT, ETC.

economical in equipment cost, and only requires a CNR of 8 dB for BER = 10^{-4} . This error rate is more than adequate compared to outages due to blocking and unattendance.

In a single beam satellite the maximum call rate is based on 2500 available 4 kHz SSB trunk slots (in 10 MHz). For grade of service of .01 (few calls are rejected) and assuming 100 seconds per call, the call rate will be approximately 25 calls per second during the busy hours. If the signalling channel rate capability is 12 KBPS toward the NOC, the throughput, for slotted ALUHA is approximately 3 KBPS. Using gateway to NOC block capacity of 155 bits, described in Table 4.2-1, the call response is 3 KBPS/155 bits per call = 43 calls per second toward the NOC. This is more than sufficient because:

1. channel slots smaller than 4 kHz are not practical
2. not all trunks use SSB
3. not all trunks are demand assigned

The call response outward from the NOC is efficient TDM and its channel capability is, therefore, much higher.

Note that signalling channel requirements for multibeam satellites are different. This capacity is

$$R \frac{N}{4} \text{ where}$$

R = single beam signalling channel requirements
(different for NOC "in" and NOC "out")
N = number of beams

derived considering that only one fourth the single beam capacity is available per beam. Thus a 12 beam satellite requires a common signalling channel capacity which is three times that of the single beam satellite; a hundred beam satellite requires 25 times the single beam capacity. This capacity is neglected in the traffic capacity estimates for the various satellites.

The gateway block diagram, given in Figure 4.2-6, describes an S-Band only, typical SCPC configuration with channel assignment on demand. Redundancy is not shown and probably is not needed. The gateway operates on either polarization plan, but with a single satellite. The common signalling channel is available at all times (for frequency stabilization, AGC etc), and of course, in band signalling is available during "conversations".

4.2.1.4 Weight and Power Summary

Figure 4.2-7 summarizes the antenna and receiver subassembly weights and powers for Concept A. Figure 4.2-8 summarizes the transmitter subassembly weights and powers based on the nominal performance parameters. The UHF antenna peak gain is 28.2 dB, and the average gain over the beamwidth is estimated to be 26.7 dB. Considering 1 dB output loss, CFM (15 KHz centers) and a 4 dB VOX factor and 35% overall efficiency the total UHF transmitter power is 174watts, as derived at the bottom of Figure 4.2-8.

| | | |
|----------------------------|---|---|
| MAXIMUM SATELLITE CAPACITY | = | 2500 4 KHz SSB TRUNKS (1 BEAM SATELLITE ONLY) |
| GRADE OF SERVICE | = | 0.01 |
| AVERAGE CALL | = | 100 SECONDS |
| CALL RATE, TYPICAL | = | 25 CALLS PER SECOND DURING BUSY HOUR (MAXIMUM) |
| CSC RATE | = | 12 KBPS (RAW RATE) - (TDM THROUGHPUT FROM NOC) |
| CSC THROUGHPUT | = | 3 KBPS (SLOTTED ALOHA), TOWARD NOC |
| CALL RESPONSE | = | $\frac{3 \text{ KBPS}}{128 \text{ BITS/CALL}} \times 2 = 46 \text{ CALLS PER SECOND (2 CSC LINKS)}$ |

- NOT ALL TRUNKS ARE SSB
- NOT ALL TRUNKS REQUIRE SIGNALLING (TPL, ETC.)
- 2500 MAXIMUM CHANNELS PER BEAM IS PERTINENT ONLY TO 1 BEAM SATELLITE
- 100 BEAM SATELLITE REQUIRES INCREASED CSC CAPACITY OF 6.25 TIMES
- 12 BEAM SATELLITE REQUIRES INCREASED CSC CAPACITY OF 3/4 TIMES

NOTE:

SIGNALLING FOR DISPATCH (AUTOMATIC DIALING) IMPROVES SATELLITE UTILIZATION, PARTICULARLY FOR SMALL NETWORKS, AND PARTICULARLY FOR MULTIBEAM SATELLITES. SHORT STANDARD (ROUTING) MESSAGES COULD BE PACKETIZED FOR TPL OPERATIONS

Figure 4.2-6. One Beam Satellite, Common Signalling Channel Requirements Voice

| ANTENNA ASSEMBLY | QUANTITY | UNIT WT LB | TOTAL WT LB | TOTAL ECLIPSE POWER WATTS | TOTAL DAYTIME POWER WATTS |
|--------------------------------|-----------|---------------|-----------------|------------------------------------|------------------------------------|
| REFLECTOR (12') | 1 | 30 | 30 | 0 | 0 |
| DIOCHROIC & FEED ASS'Y (S&UHF) | 2 + 3 + 1 | 0.2 & 1 | 2 | 0 | 0 |
| SUPPORT & DEPLOYMENT | 1 ASSY | 20 | 20 | 0 | 0 |
| OMT (S&UHF) | 2 | 0.2 | 0.4 | 0 | 0 |
| MISC/CONTINGENCY | | | 5.2 | | |
| SUBTOTAL | | | 51.6 LBS | | |
| UHF RECEIVER ASS'Y | | | | | |
| CABLES/WAVEGUIDES | 1 SET | 0.5 | 0.5 | | |
| POL SWITCH | 1 | 0.1 | 0.1 | | |
| PRESELECTION FILTER | 1 | 4.3 | 4.3 | | |
| LNA & SWITCH | 2 | 1.4 | 2.8 | 1.0 | 1.0 |
| INPUT FILTER | 1 | 5.4 | 5.4 | | 0 |
| IFA | 2 | 1 | 2.0 | 1.5 | 1.5 |
| UPCONVERTER ASS'Y | 2 | 0.5 | 1.0 | 0 | 0 |
| LO & SWITCHING | 3 | 1.7 | 5.1 | 3 | 3 |
| MISC/CONTINGENCY | 1 SET | | 2.1 | 0.6 | 0.6 |
| SUBTOTAL | | | 23.3 LBS | 6.1 WATTS | 6.1 WATTS |
| S BAND RECEIVER ASS'Y | | | | | |
| CABLES/WAVEGUIDES | 1 SET | 0.5 | 0.5 | | |
| POL SWITCH | 1 | 0.1 | 0.1 | | |
| PRESELECTION FILTER | 1 | 1.4 | 1.4 | | |
| LNA & SWITCH | 2 | 1.4 | 2.8 | 1.0 | 1.0 |
| INPUT FILTER | 1 | 1.8 | 1.8 | | |
| SWITCHES, REDUNDANCY | N/A | -- | -- | | |
| LO & SWITCHING | N/A | -- | -- | | |
| DOWNCONVERTER ASS'Y | 2 | 0.5 | 1.0 | | |
| MISC/CONTINGENCY | | | 0.8 | 0.1 | 0.1 |
| SUBTOTAL | | | 8.4 LBS | 1.1 WATTS | 1.1 WATTS |

Figure 4.2-7. Concept A Antenna and Receiver Weight and Power

| ANTENNA ASSEMBLY | QUANTITY | UNIT WT LB | TOTAL WT LB | TOTAL ECLIPSE POWER WATTS | TOTAL DAYTIME POWER WATTS |
|-----------------------------------|----------|---------------|-----------------|------------------------------------|------------------------------------|
| UHF TRANSMITTER SECTION | | | | | |
| CABLES, WAVEGUIDES | 1 SET | 1.0 | 1.0 | | |
| NOTCH FILTER | 1 | 5.4 | 5.4 | | |
| OUTPUT FILTER | 1 | 5.4 | 5.4 | | |
| POWER AMPLIFIER | 2 | 1.6 | 3.2 | 124 | 497 |
| PA SWITCHING | 2 | 0.3 | 0.6 | | |
| ATTENUATOR | 2 | 0.1 | 0.2 | | |
| SWITCHES (REDUNDANCY) | 2 | 0.1 | 0.2 | | |
| MISC/CONTINGENCY | | | 1.6 | 12 | 50 |
| SUBTOTAL | | | 17.6 LBS | 136 LBS | 547 WATTS |
| S BAND TRANSMITTER SECTION | | | | | |
| CABLES, WAVEGUIDES | 1 SET | 1.0 | 1.0 | | |
| NOTCH FILTERS | 1 | 1.8 | 1.8 | | |
| OUTPUT FILTER | 1 | 1.8 | 1.8 | | |
| POWER AMPLIFIER | 2 | 0.62 | 1.24 | 11.6 | 11.6 |
| PA SWITCHING | 2 | 0.3 | 0.6 | | |
| ATTENUATOR | 2 | 0.1 | 0.2 | | |
| SWITCHES (REDUNDANCY) | 2 | 0.1 | 0.2 | | |
| MISC/CONTINGENCY | | | 0.7 | 1.2 | 1.2 |
| | | | 7.5 LBS | 13 WATTS | 13 WATTS |

G(UHF) = 28.2 dBi PEAK, AVERAGE GAIN \approx 26.7 dB

G(S) = 27 dBi MIN \rightarrow 28.5 dBi AVERAGE (LITTLE SHAPING)

$P(\text{UHF}) = 23.9 \text{ dBw} + 10 \text{ LOG } \frac{10\text{M}}{15\text{K}} + 1 - 26.7 - 4 = 22.4 \text{ dBw} (174 \text{ WATTS})$

DCP(UHF) = $174/0.35 = 497 \text{ WATTS}$ (25% OR 124 WATTS DURING ECLIPSE)

$W(\text{UHF}) = 0.75 + 0.25 \frac{P(\text{UHF})}{50} = 1.6 \text{ LBS}$

Figure 4.2-8. Concept A Transmitter Weight and Power

Similarly, the S-Band transmitter power and weight also are derived in Figure 4.2-8.

Figure 4.2-9 summarizes two additional cases, Case A1 wherein satellite power at UHF is increased by 5 dB, and Case A2 for a 10 dB increase. This range of power represents choices in system performance (e.g. margins) which cannot be defined accurately, and for choices in various system parameters, such as mobile vehicle antenna gain, which need to be evaluated parametrically. Figure 4.2-9 summarizes the payload weight and power for cases A, A1 and A2 and converts these into spacecraft in-orbit, beginning of life mass. The payload as defined represents 45% of total space weight (mass) based on 7 year life, full north/south station keeping and partial eclipse capability (25% of daytime capability). It may be noted that spacecraft weight is relatively small for the spacecraft power generated principally because the transponder arrangements are simple and the solid state power amplifiers are relatively light weight. A 10 dB increase in UHF power increases satellite weight by 246%.

| | WT (LBS) | | | POWER (WATTS) | | |
|-----------------------|-----------|-----------|-----------|---------------|------------|-------------|
| | A | A1 | A2 | A | A1 | A2 |
| ANTENNA ASS'Y | 57.6 | 57.6 | 57.6 | 0 | 0 | 0 |
| UHF RECEIVER ASS'Y | 23.3 | 23.3 | 23.3 | 6.1/6.1 | 6.1/6.1 | 6.1/6.1 |
| S-BAND RECEIVER ASS'Y | 8.4 | 8.4 | 8.4 | 1.1/1.1 | 1.1/1.1 | 1.1/1.1 |
| UHF TRANSMITTER ASS'Y | 17.6 | 21.4 | 33.3 | 547(156) | 1728/32 | 5462/1365 |
| S TRANSMITTER ASS'Y | 7.5 | 7.5 | 7.5 | 13/13 | 13/13 | 13/13 |
| HOUSEKEEPING | -- | -- | -- | 200/200 | 200/200 | 200/200 |
| SUBTOTAL | 114.4 LBS | 118.2 LBS | 130.1 LBS | 767/356 W | 1948/652 W | 5682/1585 W |
| α_A (WATTS/LB) | | | | 7.5 | 8 | 10 |
| α_B (WATTS/LB) | | | | 7 | 7 | 7 |
| ARRAY WEIGHT | 102 | 244 | 568 | | | |
| BATTERY WEIGHT | 51 | 93 | 226 | | | |

TOTAL PAYLOAD WEIGHT 267 LBS 455 LBS 924 LBS
TOTAL SPACECRAFT WEIGHT 593 LBS 1012 LBS 2053 LBS

CASE A1 (+5 dB)

$$P(\text{UHF}) = 27.4 \text{ dBw (550 WATTS)}$$

$$P_{\mu}(\text{DC}) = 550/0.35 \rightarrow 1571 \text{ WATTS X } 1.1 = 1728$$

$$W(\text{UHF}) = (0.75 + 0.25 \text{ 1550}/50 = 3.5 \text{ LBS}$$

CASE A2 (+ 10 dB)

$$P(\text{UHF}) = 32.4 \rightarrow 1738 \text{ WATTS}$$

$$P_{\mu}(\text{DC}) = 4965 \text{ WATTS X } 1.1 = 5462 (1365)$$

$$W(\text{UHF}) = 0.75 + 1738/50 \text{ X } 0.25 = 9.44$$

Figure 4.2-9. Concept A Weight and Power Summary

4.2.2 SATELLITE CONCEPT B

4.2.2.1 Frequency Plan, Beam Plan and Capacity

Concept B is a moderate capacity LMSS based on 1990 technology. Concept B provides 12 beams of which 10 illuminate CONUS as illustrated in Figure 4.2-10. A typical frequency plan is given in Figure 4.2-11, showing the same UHF band, now segmented 4:1 to provide frequency reuse, and showing an expanded use of S-Band to provide capacity despite a single S-Band beam.

Dial-up voice and wideband data links are still between the mobiles and gateways (via the satellite) however signalling channels and the interactive data service always use the NOC as one end of the link. No on board switching is required. The capacity per satellite, for a total usable bandwidth of 30 MHz is 2000 15 KHz FM trunks or 7500 4 KHz SSB trunks.

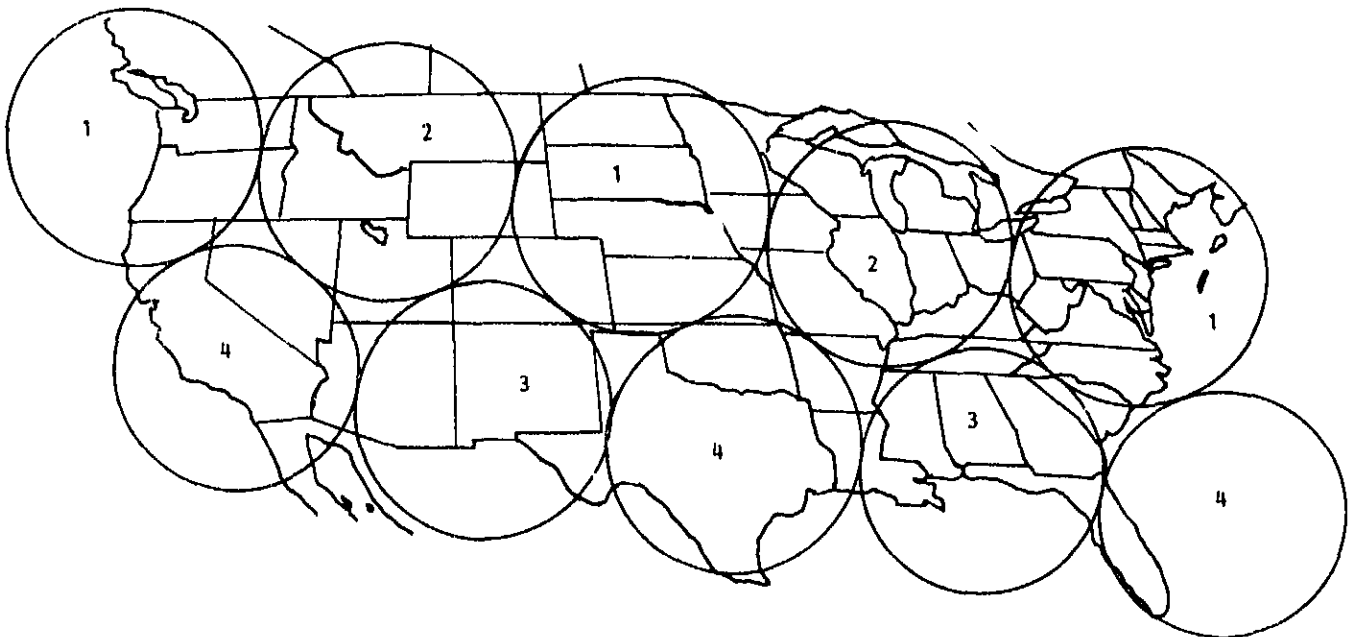
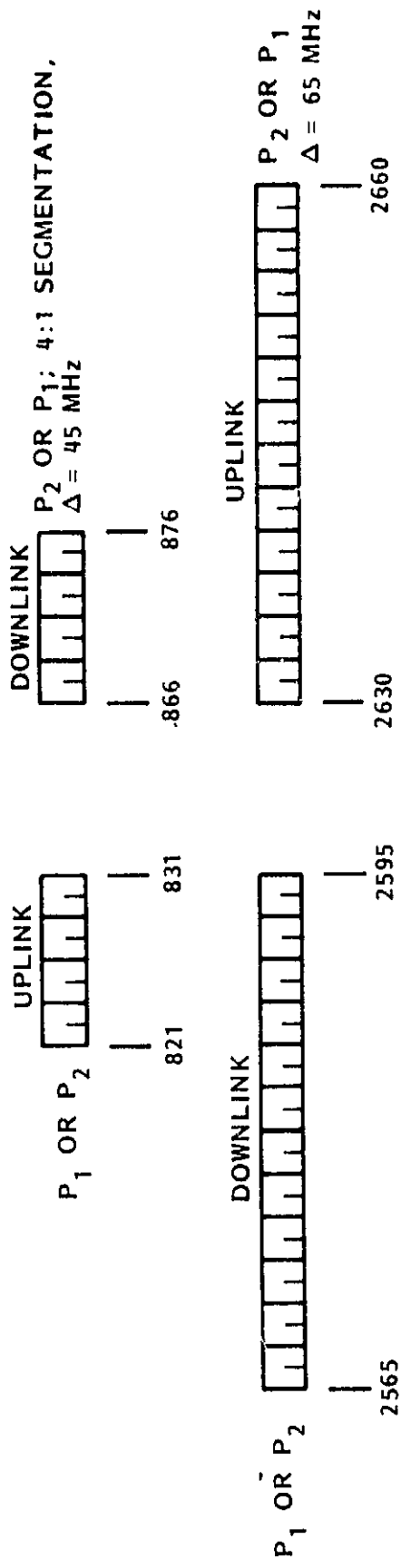

Figure 4.2-10. Concept B Antenna Coverage



12 UHF BEAMS, EITHER POLARIZATION
 1 S-BAND BEAM, EITHER POLARIZATION
 BANDWIDTH = 12 x 2.5 = 30 MHz (EACH WAY) SINGLE POLARIZATION
 = 60 MHz (EACH WAY) DUAL POLARIZATION
 NO ONBOARD SWITCHING

Figure 4.2-11. Concept B Frequency Plan

4.2.2.2 Transponder Arrangement

The transponder arrangement in Figure 4.2-12 depicts the principle arrangement. Signals received at the satellite in each 2.5 MHz UHF segment are amplified and then frequency translated to S-Band such that the 12 2.5 MHz segments are contiguous. The converse is true for the S-Band receive spectrum which is amplified, downconverted to UHF, and channelized into 2.5 MHz segments which are then individually amplified. Redundancy is 16/12 for UHF receivers and transmitters, 2/1 for S-Band receivers and transmitters and 6/3 for the upconverters and downconverters.

As for Concept A, Concept B power amplifiers are linearized, probably class AB bipolar transistors and the low noise amplifiers are GaAsFets. The LO frequencies will likely be ground controlled. Each of the 12 channels has gain drift compensation. The filtering problem is the same as for Concept B, however, the multiple beams "magnifies" the importance of the various bandpass and bandstop filters required for diplexing.

4.2.2.3 Signalling and Switching and Network Control

SCPC (FDMA) operation is retained, and channel slots are individually assigned by the NOC, as for Concept A, (each gateway has access to all the UHF beams via FDMA access). However, the NOC can be located only in one of the 12 UHF beams, and has access to only 1 of 4, frequency segments. The simple UHF/S-Band translation in the satellite can be maintained by operating the NOC only at S-Band. Mobile-NOC signalling (and interactive data) is the same as Concept A, however signalling and interactive data exchange to the gateways is maintained by adding low cost UHF capability to the gateways - basically the RF portion of the UHF mobile vehicle equipment. Consequently, the NOC operates only at S-Band, but each gateway operates at S-Band and UHF. The NOC still operates with both satellites. Two channels per UHF beam (NOC-mobile and NOC-gateway) are still sufficient for signalling. The network arrangement for signalling and interactive data exchange is illustrated in Figure 4.2-13. Figure 4.2-14 depicts the UHF/S-Band gateway wherein the signalling (to the NOC) is accomplished at UHF.

The multibeam satellite eliminates the dispatch mode of operation for dispersed networks such as transportation. In a one beam satellite a simplex operation might serve. However, in a multibeam system the calls are addressed to other beams and to maintain channel efficiency, these channels will likely

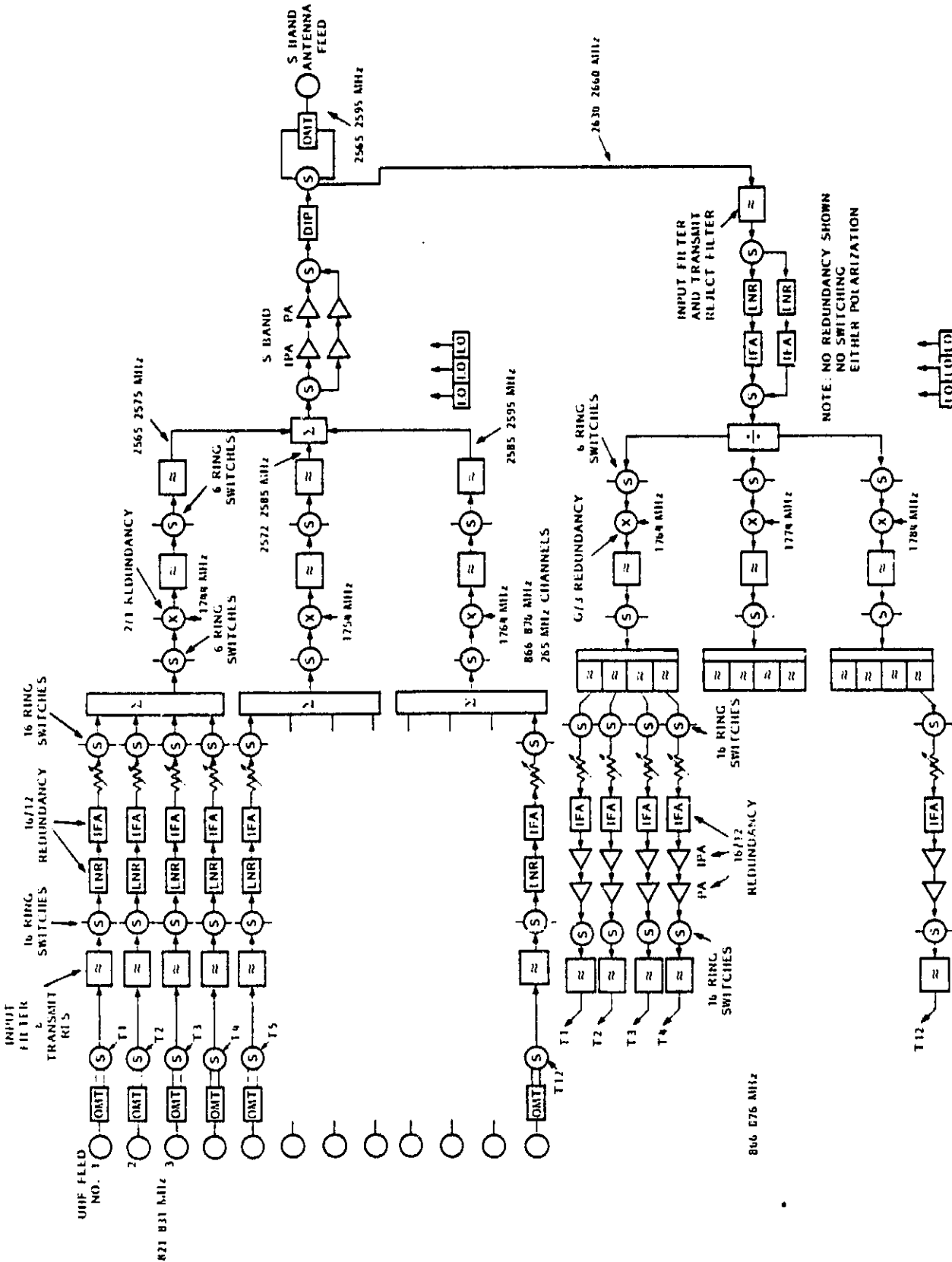

Figure 4.2-12. Concept B Transponder Concept

ORIGINAL PAGE IS
OF POOR QUALITY

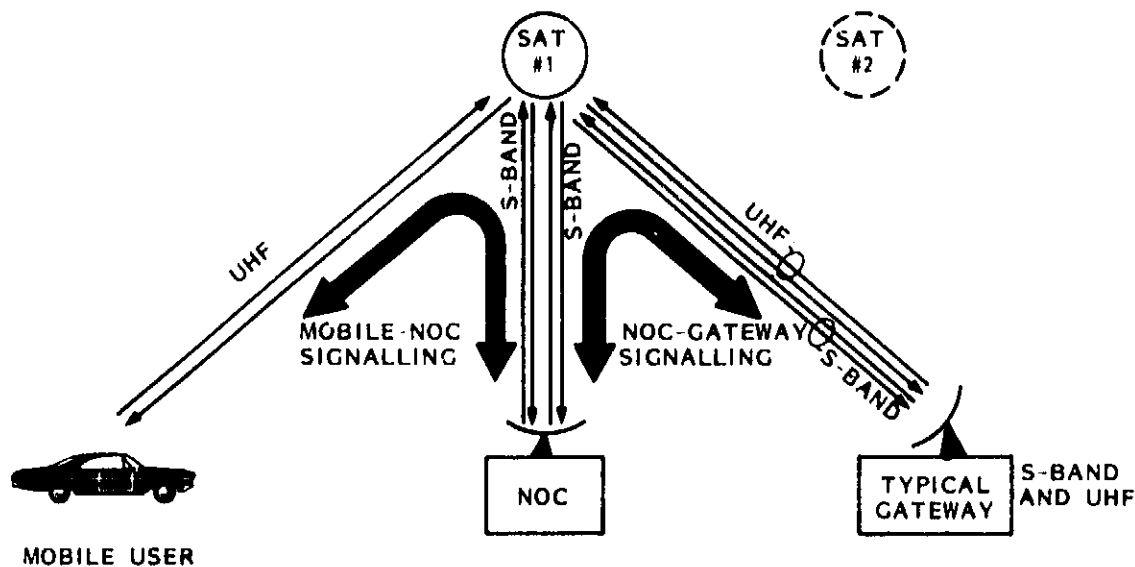

Figure 4.2-13. Concept B Common Signalling Channel Arrangement

be shared with others, requiring duplex operation with signalling. For short messages, typical of dispatch, the signalling and switching time, measured in one round trip through the satellite or approximately 0.3 seconds, might reduce channel efficiency. Dispatch traffic might be more efficient if short, routine messages could be handled via the interactive data system and the dial up trunks used only for those calls requiring more extensive conversation. Otherwise Concept A and Concept B are operationally similar.

4.2.2.4 Weight and Power Summary

Figure 4.2-15 summarizes the weight and power for the antenna and receiver subsystems, and Figure 4.2-16 for the Transmitter Subsystems. Weight and power summaries are listed in Figure 4.2-17 for the nominal case (B), and for the nominal case with 5 dB more UHF power (B1), and with 10 dB more UHF power (B2). A significant portion of the transponder weight is devoted to the filter network, for the reasons stated previously. Power requirements are quite modest for the three cases due to the high gain spot beams, and therefore satellite weight varies only 14% for a 10:1 change in UHF power.

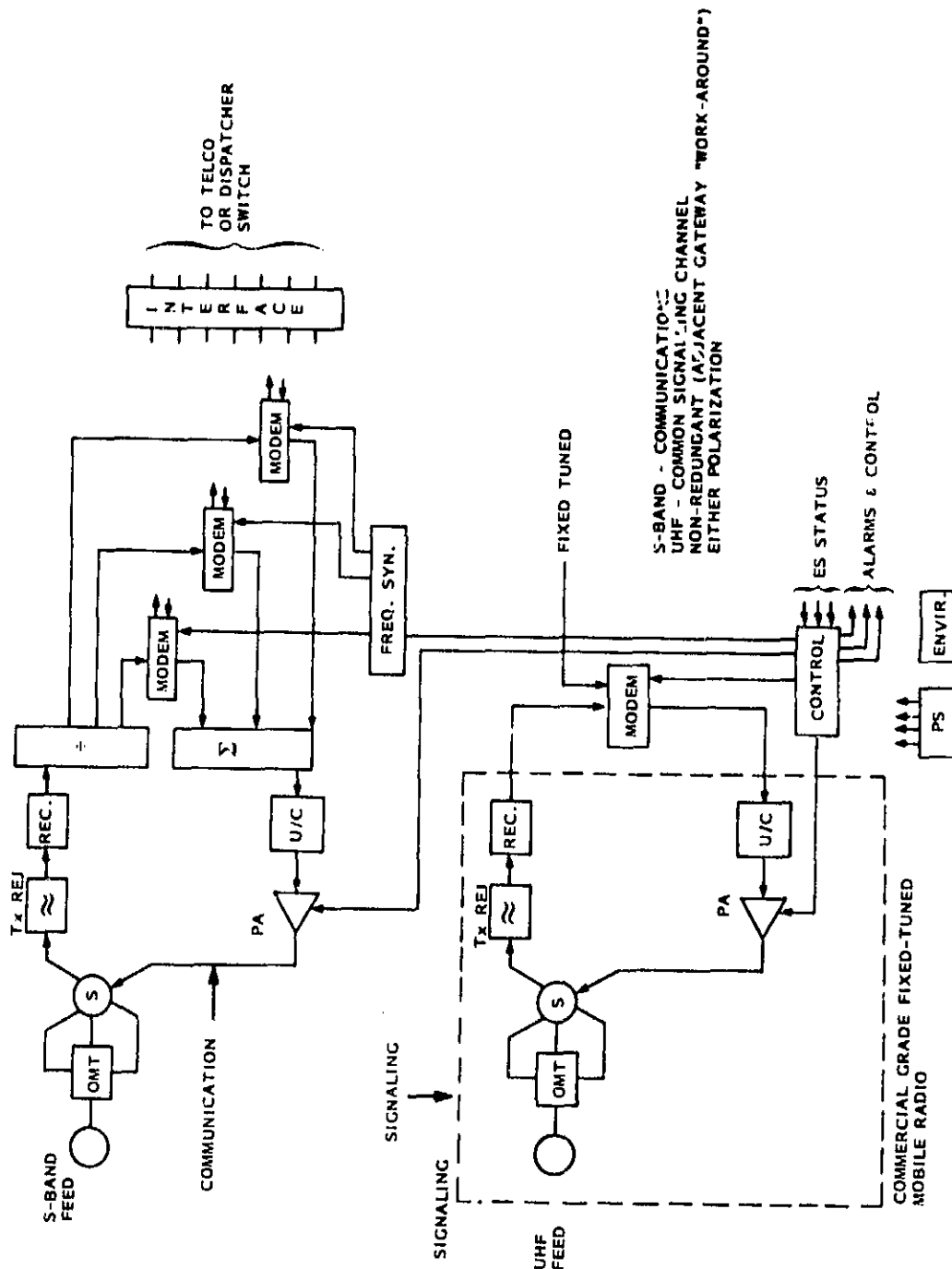

Figure 4.2-14. Gateway Terminal Block Diagram

ORIGINAL PAGE IS OF POOR QUALITY

| | QUANTITY | UNIT WT. LBS | TOTAL WT. LBS | TOTAL ECLIPSE POWER WATTS | TOTAL DAYTIME POWER WATTS |
|---------------------------------|----------|-----------------|------------------|---------------------------------|------------------------------------|
| ANTENNA ASSEMBLY | | | | | |
| REFLECTOR (51') | 1 | 108 | 108 | - | -- |
| FEED ASSEMBLY, UHF | 12 | 0.2 | 2.4 | -- | -- |
| FEED ASSEMBLY, S-BAND | 8 | 1.0 | 8.0 | - | -- |
| DIOCHROIC PANEL | 1 | 10.0 | 10 | -- | -- |
| OMT (U+S) | 12 + 8 | 0.2 | 4.0 | -- | - |
| SUPPORT | | | 30 | - | -- |
| MISC/CONTINGENCY | | | 16.2 | -- | -- |
| SUBTOTAL | | | 179 LBS | 0 | 0 |
| UHF RECEIVER ASSEMBLY | | | | | |
| POL. SWITCH | 12 | 0.1 | 1.2 | - | -- |
| INPUT FILTER/TRANS REJ. | 12 | 5.4 | 64.8 | - | -- |
| RING SWITCH (COAX) | 32 | 0.2 | 6.4 | -- | - |
| LNA | 16 | 1.2 | 19.2 | 12 | 12 |
| IFA | 16 | 1.0 | 16.0 | 18 | 18 |
| ATTENUATOR | 16 | 0.1 | 16.0 | -- | -- |
| SUMMER | 3 | 0.1 | 0.3 | -- | -- |
| CABLES & WAVEGUIDE | 1 SET | 8 | 8.0 | -- | - |
| MISC & CONTINGENCY | -- | | 13.2 | 3 | 3 |
| SUBTOTAL | | | 145 LBS | 33 WATTS | 33 WATTS |
| S-BAND RECEIVER ASSEMBLY | | | | | |
| POL. SWITCH | 1 | 0.1 | 0.1 | -- | -- |
| INPUT/TRANS REJ. FILTER | 1 | 1.8 | 1.8 | -- | -- |
| LNR | 2 | 1.2 | 2.4 | 1.0 | 1.0 |
| IFA | 2 | 1.0 | 2.0 | 1.5 | 1.5 |
| SWITCHES (RECEIVE) | 2 | 0.1 | 0.2 | -- | -- |
| DIVIDER | 1 | 0.1 | 0.1 | -- | -- |
| RING SWITCHES | 12 | 0.2 | 2.4 | -- | -- |
| CONVERTERS (6/3) | 6 | 0.5 | 3.0 | -- | -- |
| LO'S | 6 | 1.5 | 9.0 | 9 | 19 |
| CHANNEL FILTERS (UHF) | 12 | 7.3 | 87.6 | -- | - |
| CABLE & WAVEGUIDE | 1 SET | 0.5 | 0.5 | -- | -- |
| MISC & CONTINGENCY | -- | | 11.8 | -- | 1.1 |
| SUBTOTAL | | | 120.9 LBS | 12.6 WATTS | 12.6 WATTS |

Figure 4.2-15. Concept B Antenna and Receiver Weights and Powers

| | QUANTITY | UNIT WT. LBS | TOTAL WT. LBS | TOTAL ECLIPSE POWER WATTS | TOTAL DAYTIME POWER WATTS |
|-----------------------------|----------|--------------|---------------|---------------------------|---------------------------|
| UHF TRANSMITTER ASSEMBLY | | | | | |
| RING SWITCHES | 32 | 0.2 | 6.4 | -- | -- |
| ATTENUATORS | 16 | 0.1 | 1.6 | -- | -- |
| IFA | 16 | 1 | 16.0 | 18 | -- |
| PA | 16 | 0.8 | 12.8 | 30 | 18 |
| PA SWITCHING | 32 | 0.2 | 6.4 | -- | 120 |
| DIPLEXER | 12 | 5.4 | 64.8 | -- | -- |
| NOTCH FILTER | 12 | 5.4 | 64.8 | -- | -- |
| CABLES & WAVEGUIDES | 1 SET | 16.0 | 16.0 | -- | -- |
| MISC. & CONTINGENCY | -- | -- | 18.9 | 5 | 14 |
| SUBTOTAL | | | 207.7 LBS | 53 WATTS | 152.0 WATTS |
| S-BAND TRANSMITTER ASSEMBLY | | | | | |
| RING SWITCHES (CONVERTERS) | 16 | 0.2 | 3.2 | -- | -- |
| UPCONVERTERS (6/3) | 6 | 0.5 | 3.0 | -- | -- |
| LO'S (6/3) | 6 | 1.5 | 9.0 | 9 | 9 |
| SWITCHES (REDUNDANCY) | 2 | 0.1 | 0.2 | -- | -- |
| PA | 2 | 0.7 | 1.4 | 7 | 27.7 |
| PA SWITCHING | 2 | 0.20 | 0.4 | 0 | 0 |
| DIPLEXER | 1 | 1.8 | 1.8 | -- | -- |
| NOTCH FILTER | 1 | 1.8 | 1.8 | -- | -- |
| CABLES & WAVEGUIDES | 1 SET | 1.0 | 1.0 | -- | -- |
| MISC & CONTINGENCY | -- | -- | 2.2 | 1.6 | 3.7 |
| SUBTOTAL | | | 24.0 LBS | 18 WATTS | 40.4 WATTS |

G(UHF) = 40.6 dBi, AVERAGE GAIN = 38.6 dBi
 UHF PA $P_{\mu} = 23.9 + 2 + 10 \text{ LOG } 2.5\text{M}/15\text{K} - 38.6 - 4 = 5.5 \text{ dBW} \rightarrow 3.5 \text{ WATTS}$
 $P_{\mu}(\text{DC}) = 12 \times 3.5/0.35 = 120 \text{ WATTS}$
 $W(\text{UHF}) = 0.75 + 0.25 \times 3.5/50 = 0.77 \text{ LBS}$
 S-BAND G(S) = 31 dBi, AVERAGE GAIN = 29.5 dBi
 $P_s = 8.2 + 33 + 1.5 - 29.5 - 4 = 9.2 \text{ dBW} \rightarrow 8.3 \text{ WATTS}$
 $P_{\mu}(\text{DC}) = 8.3/0.3 = 27.7 \text{ WATTS}$
 $W(S) = 0.6 + 0.2 \times 8.3/30 = 0.66 \text{ LBS}$

Figure 4.2-16. Transmitter Weights and Powers

| | WT (LBS) | | | POWER (WATTS) | | |
|--------------------------|----------|----------|----------|---------------|----------|-----------|
| | B | B1 | B2 | B | B1 | B1 |
| ANTENNA ASSEMBLY | 179 | 179 | 179 | 0 | 0 | 00 |
| UHF RECEIVER ASS'Y | 145 | 145 | 145 | 33/33 | 33/33 | 33/33 |
| S-BAND RECEIVER ASS'Y | 121 | 121 | 121 | 13/13 | 13/13 | 13/13 |
| UHF TRANSMITTER ASS'Y | 208 | 208 | 210 | 152/53 | 456/129 | 1371/358 |
| S-BAND TRANSMITTER ASS'Y | 24 | 24 | 24 | 42/19 | 42/19 | 42/19 |
| HOUSEKEEPING | -- | -- | -- | 300/300 | 300/300 | 300/300 |
| SUBTOTAL | 677 LBS | 677 LBS | 679 LBS | 540/418W | 844/494W | 1759/723W |
| α_A (WATTS/LBS) | | | | 7.5 | 7.5 | 7.5 |
| α_B (WATTS/LBS) | | | | 7 | 7 | 7 |
| ARRAY WEIGHT, LBS | | | | 72 | 113 | 141 |
| BATTERY WEIGHT, LBS | | | | 60 | 71 | 103 |
| TOTAL PAYLOAD WEIGHT | 809 LBS | 861 LBS | 923 LBS | | | |
| TOTAL SPACECRAFT WEIGHT | 1798 LBS | 1913 LBS | 2051 LBS | | | |

CASE B1 (+5 dB)

$$P(\text{UHF}) = 28.9 + 2 \quad 10 \text{ LOG } 2.5\text{M}/15\text{K} - 38.6 - 4 = 10.5 \text{ dBw (11.2 WATTS)}$$

$$P_{\mu}(\text{DC}) = 12 \times 11.2/0.35 = 385 \text{ WATTS} \times 1.1 = 424 \text{ WATTS}$$

$$W(\text{UHF}) = 0.75 + 0.25 \quad 11.2/50 = 0.8 \text{ LBS}$$

CASE B2 (+10 dB)

$$P(\text{UHF}) = 15.5 \text{ dBw} \rightarrow 35.5 \text{ WATTS}$$

$$P_{\mu}(\text{DC}) = 12 \times 35.5/0.35 \times 1.1 = 1339 \text{ WATTS}$$

$$W(\text{UHF}) = 0.75 + 0.25 \quad 35.5/50 = 0.93 \text{ LBS}$$

Figure 4.2-17. Concept B Weight-Power Summary

4.2.3 SATELLITE CONCEPT C

4.2.3.1 Frequency Plan, Beam Plan and Capacity

Concept C is similar to Concept B except for the larger number of beams (31). Concept C is the highest capacity satellite capable of utilizing a single S-Band beam. Concept C provides a total capacity of 77.5 MHz or 5167 15 KHz trunks or 19375 4 KHz trunks. Operation is the same as for Concept B. A frequency plan is given in Figure 4.2-18.

4.2.3.2 Transponder Arrangement

The transponder arrangement is the same as for Concept B based on simple FDMA and frequency translation, except for the larger number of beams, transponders etc. and higher power, and the reader is referred to Figure 4.2-12 (Concept B) for a description.

4.2.3.3 Signalling, Switching and Network Control

These functions are identical to Concept B except for the higher signalling channel capacity required, e.g. $31/4 = 7.75$ times the capacity of Concept A.

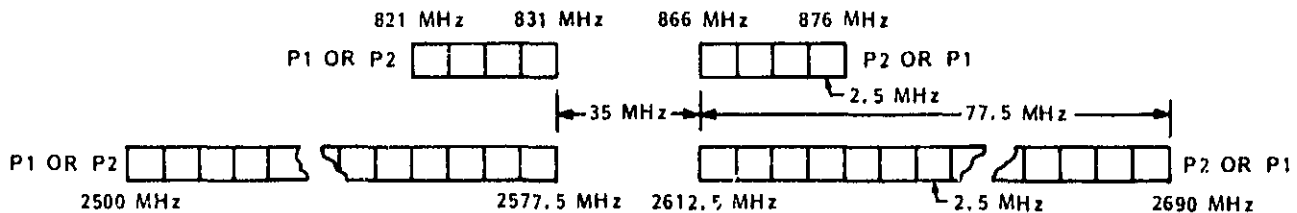

- 31 UHF BEAMS
- 1 S-BAND BEAM
- BANDWIDTH = $31 \times 2.5 \text{ MHz} = 77.5 \text{ MHz}$ PER SATELLITE
- NO ON-BOARD SWITCHING

Figure 4.2-18. Concept C Frequency Plan

4.2.3.4 Weight and Power Summary

Figure 4.2-19 summarizes the weight and power for the antenna and receiver subsystems and Figure 4.2-20 for the transmitter subsystems. Antenna and filter weight are the dominant weight items; the weight impact of power, with regard to amplifier weight and solar arrays and batteries is relatively small for C, C1 and C2. Weight and power summaries for C, C1 and C2 are given in Figure 4.2-21 for the three power levels, e.g. nominal, +5 dB and +10 dB. Over a power range of 10 dB, spacecraft total weight varies only 11%.

| | QUANTITY | UNIT WT LBS | TOTAL WT LBS | TOTAL ECLIPSE POWER WATTS | TOTAL DAYTIME POWER WATTS |
|--------------------------------------|----------|----------------|------------------|---------------------------------|------------------------------------|
| ANTENNA ASSEMBLY | | | | | |
| REFLECTOR (86 FT) | 1 | 192 | 192 | | |
| FEED ASSEMBLY, UHF | 31 | 0.2 | 6.4 | | |
| FEED ASSEMBLY, S BAND | 8 | 1.0 | 8.0 | | |
| DIOCHROIC PANEL | 1 | 10.0 | 10.0 | | |
| OMT (UHF, S BAND) | 31 + 8 | 0.2 | 7.8 | | |
| SUPPORT | 1 ASS'y | 40 | 40.0 | | |
| MISC, CONTINGENCY | | | 26.4 | | |
| SUBTOTAL | | | 297 LBS | 0 | 0 |
| UHF RECEIVER ASSEMBLY | | | | | |
| POL SWITCH | 31 | 0.1 | 3.1 | | |
| INPUT FILTER/TRANSMIT REJ. FILTER | 12 | 5.4 | 64.8 | | |
| RING SWITCH (COAX) | 80 | 0.2 | 16.0 | | |
| LNA | 40 | 1.2 | 48.0 | 31 | 31 |
| IFA | 40 | 1.0 | 40.0 | 46.5 | 46.5 |
| ATTENUATORS | 40 | 0.1 | 4.0 | | |
| SUMMERS | 8 | 0.1 | 0.8 | | |
| CABLES & WAVEGUIDE | 1 SET | 20 | 20.0 | | |
| MISC. & CONTINGENCY | | | 19.7 | 7.8 | 7.8 |
| SUBTOTAL | | | 216.4 LBS | 85.3 WATTS | 85.3 WATTS |
| S BAND RECEIVER ASSEMBLY | | | | | |
| POL SWITCH | 1 | 0.1 | 0.1 | | |
| INPUT/TRANSMIT REJ. FILTER | 1 | 1.8 | 1.8 | | |
| LNR | 2 | 1.2 | 2.4 | 1.0 | 1.0 |
| IFA | 2 | 1.0 | 2.0 | 1.5 | 1.5 |
| SWITCHES (RECEIVER) | 2 | 0.1 | 0.2 | | |
| DIVIDER | 1 | 0.1 | 0.1 | | |
| RING SWITCHES | 12 | 0.2 | 2.4 | | |
| CONVERTERS (12/8) | 12 | 0.5 | 6.0 | | |
| LO's (16/8) | 16 | 1.5 | 24.0 | 24 | 24 |
| CHANNEL FILTERS (UHF) | 31 | 7.3 | 226.3 | | |
| CABLES & WAVEGUIDE | 1 SET | 1.0 | 1.0 | | |
| MISC. & CONTINGENCY | | | 26.6 | 2.6 | 2.6 |
| SUBTOTAL | | | 292.9 LBS | 29 WATTS | 29 WATTS |

Figure 4.2-19. Concept C Antenna and Receiver Weight and Power

| | QUANTITY | UNIT WT LBS | TOTAL WT LBS | TOTAL ECLIPSE POWER WATTS | TOTAL DAYTIME POWER WATTS |
|------------------------------------|----------|----------------|-----------------|---------------------------------|------------------------------------|
| UHF TRANSMITTER ASSEMBLY | | | | | |
| RING SWITCHES | 80 | 0.2 | 16.0 | -- | -- |
| ATTENUATORS | 40 | 0.1 | 4.0 | -- | -- |
| IFA | 40 | 1.0 | 40.0 | 46.5 | 46.5 |
| PA | 40 | 0.76 | 30.4 | 26.5 | 106 |
| PA SWITCHING | 40 | 0.2 | 8.0 | -- | -- |
| DIPLEXER | 31 | 5.4 | 167.4 | -- | -- |
| NOTCH FILTER | 31 | 5.4 | 167.4 | -- | -- |
| CABLES & WAVEGUIDE | 1 | 40.0 | 40.0 | -- | -- |
| MISC & CONTINGENCY | -- | -- | 47.3 | 7.3 | 15.3 |
| SUBTOTAL | | | 521 LBS | 80 WATTS | 168 WATTS |
| S BAND TRANSMITTER ASSEMBLY | | | | | |
| RING SWITCHES (CONVERTERS) | 32 | 0.2 | 6.4 | -- | -- |
| UPCONVERTERS (12/8) | 12 | 0.5 | 6.0 | -- | -- |
| LO'S (16/8) | 16 | 1.5 | 24.0 | 24 | 24 |
| SWITCHES | 2 | 0.1 | 0.2 | -- | -- |
| PA | 2 | 0.74 | 1.5 | 17.8 | 71.3 |
| PA SWITCHING | 2 | 0.2 | 0.4 | -- | -- |
| DIPLEXER | 1 | 1.8 | 1.8 | -- | -- |
| NOTCH FILTER | 1 | 1.8 | 1.8 | -- | -- |
| CABLES & WAVEGUIDE | 1 SET | 3.0 | 3.0 | -- | -- |
| MISC. & CONTINGENCY | -- | -- | 4.5 | 4.2 | 9.5 |
| SUBTOTAL | | | 49.6 LBS | 46 WATTS | 104.8 WATTS |

$G(\text{UHF}) = 45.2 \text{ dBi}$, PEAK; AVERAGE GAIN = 43.2 dBi

$P(\text{UHF}) = 23.9 + 2 + 10 \text{ LOG } 2.5\text{M}/15\text{K} - 43.2 - 4 = 0.92 \text{ dBw} \rightarrow 1.2 \text{ WATTS}$

$P_u(\text{DC}) = 31 \times 1.2/0.35 = 106 \text{ WATTS}$

$W(\text{UHF}) = 0.75 + 0.25 \times 1.2/50 = 0.76 \text{ LBS}$

$G(\text{S}) = 31 \text{ dBi}$, AVERAGE GAIN = 29.5 dBi

$P_s = 8.2 + 37.1 + 1.5 - 29.5 - 4 = 13.3 \text{ dBw} \rightarrow 21.4 \text{ WATTS}$

$P_s(\text{DC}) = 21.4/0.3 = 71.3 \text{ WATTS}$

$W(\text{S}) = 0.6 + 0.2 \times 21.4/30 = 0.74 \text{ LBS}$

Figure 4.2-20. Concept Transmitter Weight and Power

| | WEIGHT (LBS) | | | | POWER (WATTS) | | | |
|------------------------------|--------------|----------|----------|--|---------------|----------|-----------|--|
| | C | C1 | C2 | | C | C1 | C2 | |
| ANTENNA ASSEMBLY | 291 | 291 | 291 | | 0 | 0 | 0 | |
| UHF RECEIVER ASSEMBLY | 216 | 216 | 216 | | 85/85 | 85/85 | 85/85 | |
| S-BAND RECEIVER ASS'Y | 293 | 293 | 293 | | 29/29 | 29/29 | 29/29 | |
| UHF TRANSMITTER ASS'Y | 521 | 521 | 523 | | 168/80 | 442/149 | 1270/356 | |
| S-BAND TRANSMITTER ASS'Y | 50 | 50 | 50 | | 105/46 | 105/46 | 105/46 | |
| HOUSEKEEPING | -- | -- | -- | | 300/300 | 300/300 | 300/300 | |
| SUBTOTAL | 1371 LBS | 1371 LBS | 1573 LBS | | 687/540W | 961/609W | 1789/816W | |
| α_A (WATTS/LB) | | | | | 7.5 | 7.5 | 8.0 | |
| α_B (WATTS/LBS) | | | | | 7 | 7 | 7 | |
| ARRAY WEIGHT, LBS | | | | | 92 | 128 | 224 | |
| BATTERY WEIGHT, LBS | | | | | 77 | 87 | 117 | |
| TOTAL PAYLOAD WEIGHT, LBS | 1540 | 1586 | 1714 | | | | | |
| TOTAL SPACECRAFT WEIGHT, LBS | 3422 | 3524 | 3809 | | | | | |

CASE C1 (= 5 dB)

$$P(\text{UHF}) = 5.92 \text{ dBw} \rightarrow 3.9 \text{ WATTS}$$

$$P_{\mu}(\text{DC}) = 31 \times 3.9/0.35 \times 1.1 = 380 \text{ WATTS}$$

$$W(\text{UHF}) = 0.75 + 0.25 (3.9/50) = 0.77 \text{ LBS}$$

CASE C2 (+ 10 dB)

$$P(\text{UHF}) = 10.92 \text{ dBw} \rightarrow 12.4 \text{ WATTS}$$

$$P_{\mu}(\text{DC}) = 31 \times 12.4/0.35 \times 1.1 = 1208 \text{ WATTS}$$

$$W(\text{UHF}) = 0.75 + 0.25 (12.4/50) = 0.81 \text{ LBS}$$

Figure 4.2-21. Concept C Weight-Power Summary

4.2.4 SATELLITE CONCEPT D

4.2.4.1 Frequency Plan, Beam Plan, Switching Plan and Capacity

Concept D is a 100 beam high capacity LMSS with the fixed link at S-Band, making use of a multibeam S-Band antenna system. Signals must now be routed between UHF and S-Band beams, and on board switching is needed to establish the specific routing needed. Figure 4.2-22 depicts a UHF beam plan showing 97 beams, 0.41° each, covering CONUS. The other beams cover the Alaska, Hawaii and Puerto Rico. The frequency plan depicted in Figure 4.2-23, is based on 4:1 segmentation of the UHF and S-Band allocations. The S-Band plan is based on a 70 MHz bandwidth divided into four 17.5 MHz segments; each 17.5 MHz segment is equivalent to seven 2.5 MHz UHF segments. The UHF bandwidth resulting is $2.5 \text{ MHz} \times 100 = 250 \text{ MHz}$; equivalent to 16667 15 Khz trunks or 62500 4 Khz trunks, (less an allowance for filtering).

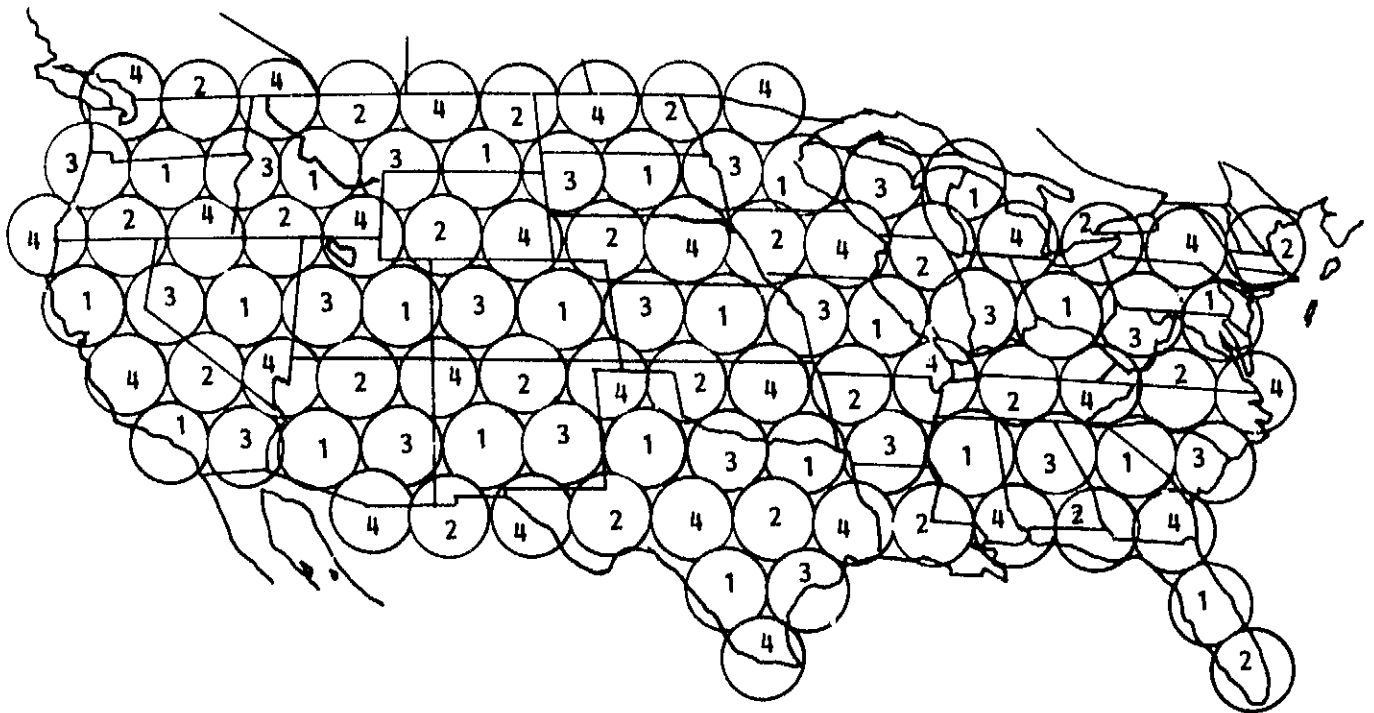
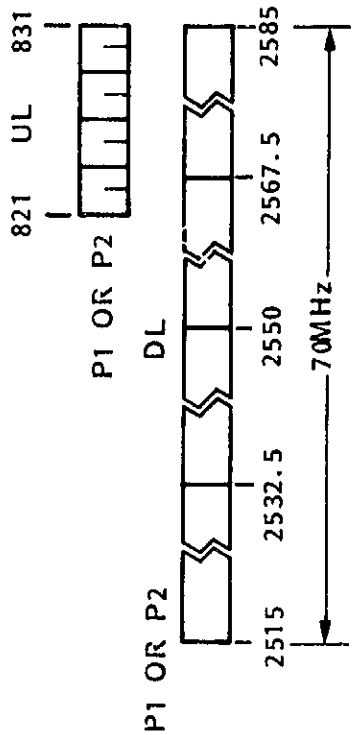
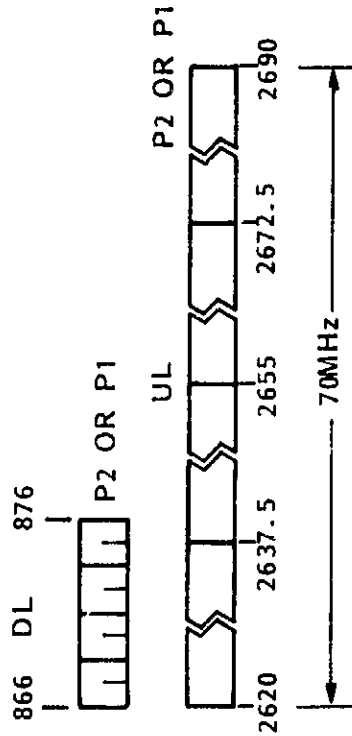

Figure 4.2-22. Concept D Antenna Beam Coverage



4:1 SEGMENTATION @ UHF

4:1 SEGMENTATION @ S-BAND



UHF (2.5 MHz)

S-BAND (17.5 MHz)

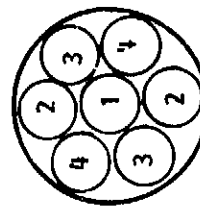

ORIGINAL PAGE IS
OF POOR QUALITY

Figure 4.2-23. Concept D Frequency Plan

Since the S-Band multibeam antenna is large, around 17 feet, a configuration combining the two apertures was investigated, in order to save weight and achieve a simpler spacecraft configuration avoiding the deployment and pointing of two individual apertures. Since different numbers of beams are required at UHF and at S-Band it is not practical to "interleave" the two feed arrays. An alternative is to use a dichroic element transparent to UHF energy but reflecting S-Band energy thus establishing an additional focus at F_s , as depicted in Figure 4.2-24. The resulting antenna configuration is not attractive, however, because the large F/D required for good side lobe performance at UHF requires excessively large S-Band feeds - the S-Band feed array is larger than the S-Band effective aperture.

4.2.4.2 Transponder Arrangement

It appears that a full switching capability is indicated in view of the uncertainty connected with the routing of the various services. Like the fixed services, mobile radio users also are concentrated in urban centers, areas of high population density and high activity. Fixed service satellites essentially provide communications between these urban centers, primarily over the longer routes. In mobile radio however, the bulk of the traffic is local to the urban centers (radio telephone) or short range (trunking), so that the LMSS portion of this traffic distribution cannot be obtained by analogy with the fixed services. For example, trucking routes are primarily between major centers, and communications along the route is important to this industry. However, a "snapshot" of truck density at any particular time will likely show concentrations near urban centers (source and destination of loads). Consequently Concept D does not assume a priori knowledge of the beam routing (an alternative configuration, E avoids on-board switching by using Ku-Band with a single antenna beam for the fixed links).

The FDMA hierarchy should accommodate any mix of service bandwidths, 4 KHz, 15 KHz or 30 KHz (these may be placed in homogeneous groups within the spectrum however to control intermodulation effects), and any mix of carrier power, on demand. Switching is needed, particularly because of the limited bandwidth available. For example, each 2.5 MHz UHF segment can contain only 625 4 KHz channel slots or 166 15 KHz channel slots, or some mix thereof. These channel slots can have 15 possible destinations (the 15 S-Band beams) or an average of 42 4 KHz slots per route or 11 15 KHz slots per route, or some mix thereof. The same is true in the reverse direction (S-Band to UHF) because the larger

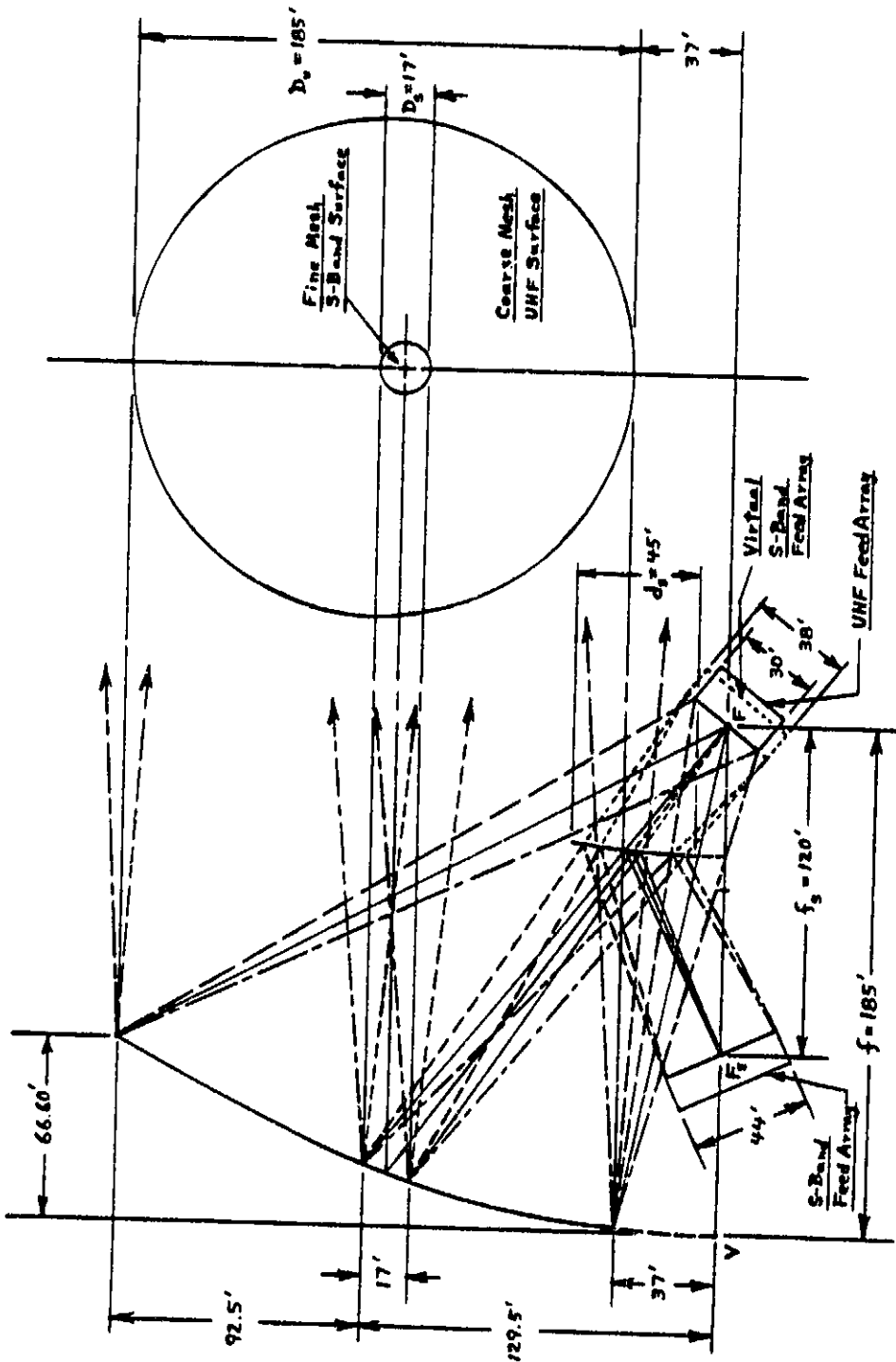

Figure 4.2-24. Antenna Concept for Combined UHF & S-Band Operation

ORIGINAL PAGE IS
OF POOR QUALITY.

beam bandwidth, (and traffic capacity) must be divided into 100 routes (per S-Band beam). Since access in this concept is strictly on an FDMA basis (the destination beam or route is determined only by the frequency of the uplink carrier) the on-board channelization defines routing bandwidths necessary to provide the network connectivity - this is not directly related to the carrier bandwidths. For example 2.5 MHz divided into 15 possible routes results in 167 KHz per route. This route bandwidth however also is a measure of the spectral efficiency of the FDMA system since each route, in this case, can only be trimmed to within 167 KHz (a single carrier required from UHF beam i to S-Band beam kk requires a 167 KHz allocation for a 4 KHz signal) - this removes bandwidth that might be needed on another route. On the other hand, if the routing bandwidth is too small, the number of channelization and switching elements increases substantially. Of course, the minimum routing bandwidth available must not be smaller than the largest bandwidth signal. While a detailed study of traffic and service patterns is needed to select the optimum channelization plan, a reasonable compromise is the following:

each 2.5 MHz segment is divided into:

| | |
|----|---------------------------------|
| 17 | 112 KHz routes (1904 KHz total) |
| 13 | 28 KHz routes (364 KHz total) |

resulting in a spectrum utilization of 90%, with 30 routes per beam to be allocated amongst 15 possible routes, with an incremental bandwidth of 28 KHz (+ 14 KHz) for trimming. Each route handles multiples of 4 KHz. The UHF and S-Band receivers each contains $100 \times 30 = 3000$ routing channels. A single multipoint LSI switch is envisioned. It should be noted in passing that both receivers access the same switch so that it is possible to set up UHF to UHF routes e.g. mobile to mobile communications. The FDMA arrangement is described in Figure 4.2-25.

Each UHF receiver amplifies the 2.5 MHz band of signals and downconverts this band to a convenient IF for channelization. Channelization filtering via light weight SAW filters and switching via a CMOS-SOS LSI crosspoint switch matrix are convenient in the 10-50 MHz region. It is important, because of the number of channelization and switching units involved, that the functions of these be kept to a minimum to save weight and power. Thus all amplification should occur before channelization or after dechannelization, and only one channelization filter is needed; dechannelization does not require a channel filter.

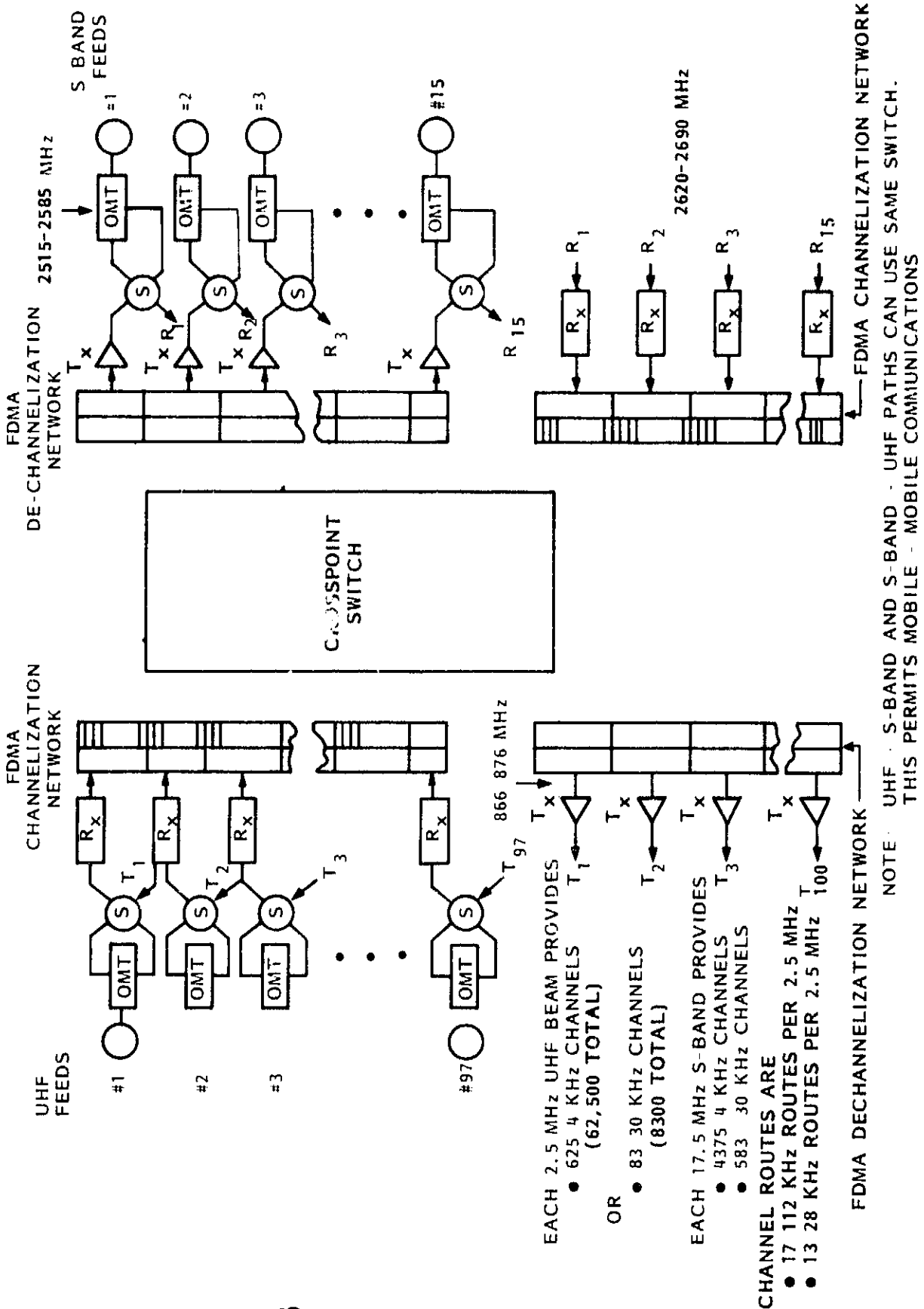

Figure 4.2-25. Concept D Transponder Concept

ORIGINAL PAGE IS OF POOR QUALITY

The diagram illustrates a single crosspoint switch matrix fed by both UHF and S-Band receiver systems. Each FDMA channelization network contains the 30 routing filters per 2.5 MHz allocation.

Figure 4.2-26 illustrates the channelization functions. It is assumed that sufficient signal levels can be maintained to avoid amplifiers and other extraneous elements so that the channelization unit functions are limited to (1) frequency translation (down and up), (2) channelization (once), and (3) switching, to minimize weight and power. Weight and power considerations also argue against redundancy in the channelization and switching systems. First because the units, as defined above, will have a high reliability, the SAW is a passive device and the mixer can be quad-redundant. Second the system will tolerate a significant number of failures.

For example, loss of a switch connection via an open merely prevents an i-j route from being provided (this route can be provided by another channel unit using different switch points). Loss of a switch connection via a short makes that i-j route a fixed route. Thus, as the switch fails, flexibility slowly degrades. Loss of a channel unit (a mixer failure), loses bandwidth/capacity but again, flexibility slowly degrades. The LO signals for channelization can be generated from a comb synthesizer whose weight and power are not significant.

Technology for channelization and switching is discussed in references (1) and (2). In summary the mixer can be a gallium arsenide beam-lead Schottky diode in a balanced configuration, channel filter is a SAW and the switch can be a crosspoint or tandem switch CLOS type. Use of the latter results in less switch points but the former contains a higher degree of redundancy. The CLOS switch and CMOS-SOS technology is assumed for this study.

4.2.4.3 Signalling, Switching and Network Control

Access is still provided by FDMA. Normally the on-board switching is set to emulate the requirements of the busy hour. Thus the on-board switches are not changed unless the traffic exceeds the available bandwidth on a given route, causing excessive blocking, (deteriorated grade of service), or the long term evolution of the network changes. Consequently, the basic SCPC/DAMA architecture previously described is still used. Calls are established on

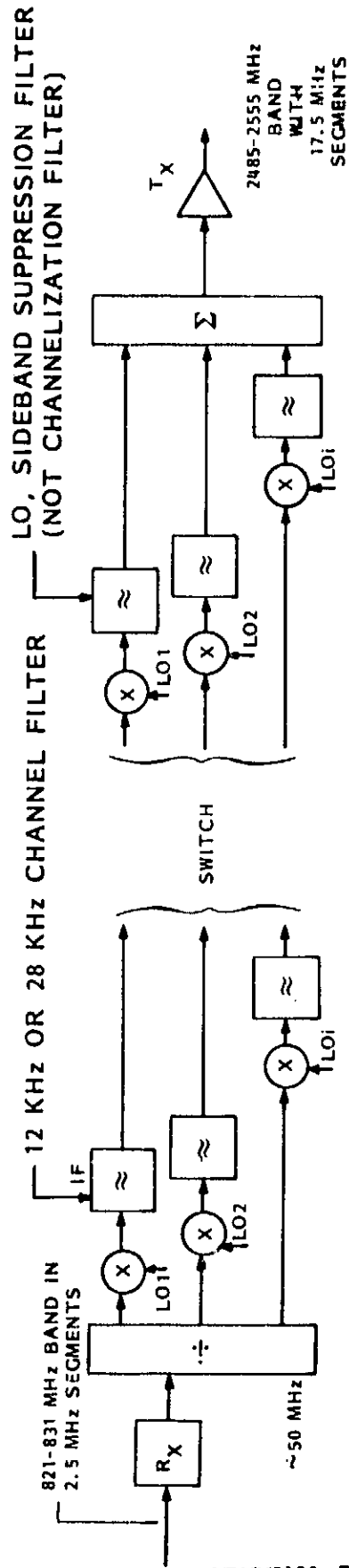

Figure 4.2-26. Concept D FDMA Channelization Network Concept

request via the common signalling channel to the centralized NOC by the NOC assigning channel slot pairs from an available pool. This then enables normal in-band telephone signalling to be used to complete the call connection. The NOC controls the bandwidth and gateway HPA power levels assigned according to the request and according to the availability.

Figure 4.2-27 illustrates the three basic signalling and communications modes. Dial-up voice and wideband data etc. are provided, as before, between the gateways and the mobiles. Signalling is still between the NOC and mobiles, and the NOC and gateways although the capacity must now be increased by 25 times that of the single beam Concept A case to handle the increased signalling requirement. This can be accomplished by adding more identical signalling channels (each private network is assigned to one of them) or adding one or more larger capacity signalling channels. However, each private network has its own signalling channel, in each beam. A mobile selects its beam by selecting the signalling channel having the strongest signal, out of the four available. It must communicate this selection back to the NOC so that the NOC can page it when necessary. Gateway operation is the same as before at UHF and S-Band. The NOC operates only at S-Band. The interactive data system operates as before, with links between the mobiles and NOC and between the gateways and NOC. Direct packet communications between the mobiles and gateways would be chaotic and inefficient because of the multibeam operation.

4.2.4.4 Weight and Power Summary

Figure 4.2-28 summarizes the weight and power requirements for the antenna and UHF receiver assembly. The UHF receiver includes 30 channel units per beam, or 3000 total, however the principle weight consists of the CLOS switch matrix which includes switching for both the UHF to S-Band and S-Band to UHF paths. The actual switch point electronics consists of several transistors (reference 1 and 2) which must be biased "on" regardless of the switch state. Since the power is large it is tempting to shut down portions of the switch during the light traffic eclipse periods however it is not clear how this can be done.

- VOICE COMMUNICATIONS (AND WIDEBAND DATA)
- POCKET (DATA) COMMUNICATIONS
- TPL

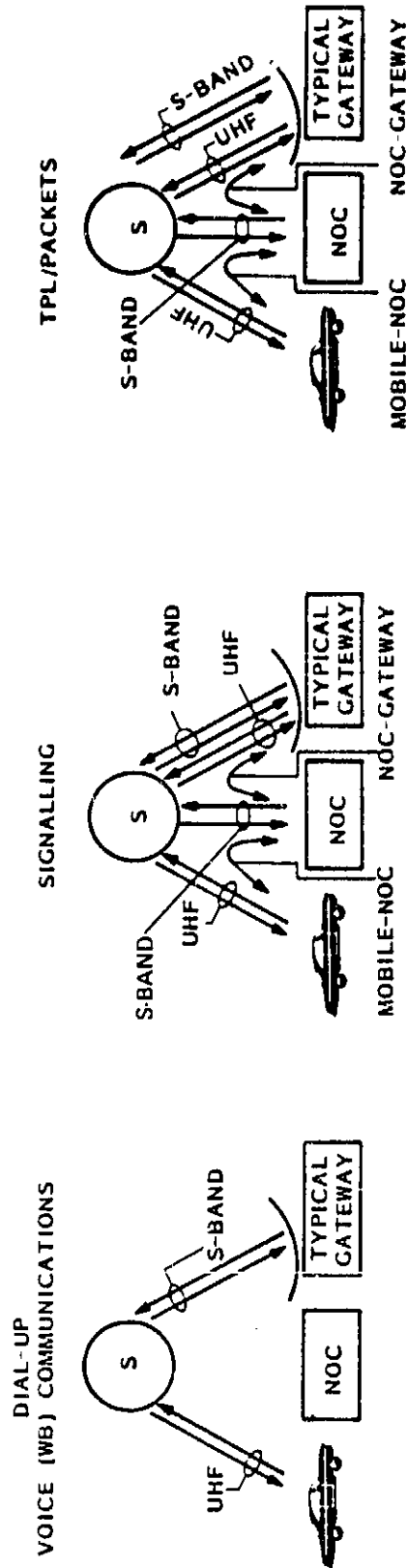

Figure 4.2-27. Concept D Communications and Signalling Arrangements

| | QUANTITY | UNIT WT LBS | TOTAL WT LBS | TOTAL ECLIPSE POWER WATTS | TOTAL DAYTIME POWER WATTS |
|-----------------------------------|----------|----------------|-----------------|---------------------------------|------------------------------------|
| ANTENNA ASSEMBLY | | | | | |
| UHF/S REFLECTOR 185', 0.41° | 1 | 852 | 852 | | |
| UHF FEED ASSEMBLY 57.1', 1.33° | 100 | 0.2 | 20 | | |
| S-BAND FEED ASSEMBLY | 15 | 1.0 | 15 | | |
| DIOCHROIC PANEL | 1 | 15 | 15 | | |
| OMT'S (UHF) | 100 | 0.1 | 10 | | |
| OMT'S (S) | 15 | 0.1 | 1.5 | | |
| SUPPORT & DEPLOYMENT | | | 95 | | |
| MISC. & CONTINGENCY | | | 101 | | |
| SUBTOTAL | | | 1110 LBS | | 0 |
| UHF RECEIVER | | | | | |
| POL SWITCH | 100 | 0.1 | 10 | | |
| INPUT/TRANSMIT REJ. FILTER | 100 | 5.4 | 540 | | |
| RING SWITCH | 250 | 0.2 | 50 | | |
| LNA | 125 | 1.0 | 12.5 | 100 | 100 |
| ATTENUATOR | 125 | 0.1 | 12.5 | | |
| CONVERTER | 125 | 0.5 | 62.5 | | |
| IFA | 125 | 1.0 | 125 | 150 | 150 |
| CHANNELIZATION DIVIDER/ SUMMER | 200 | 0.1 | 20 | | |
| LO & SWITCHING | 4 + 4 | 1.5 + 0.4 | 15.2 | 24.0 | 24 |
| CHANNELIZATION UNITS* | 3,000 | 0.05 | 150 | 300 | 300 |
| SWITCH MATRIX | 944,000 | 0.001 | 944 | 6,608 | 6,608 |
| CABLES & WAVEGUIDE | 1 SET | 50 | 50 | | |
| MISC. & CONTINGENCY | | | 199 | 718 | 718 |
| SUBTOTAL | | | 2,191 LBS | 7,900 WATTS | 7,900 WATTS |

* UP/DOWN CONVERSION, ONE CHANNEL FILTERS, ONE LO FILTER, MMIC TECHNOLOGY

Figure 4.2-28. Concept D Antenna and UHF Receiver Weight and Power

Figure 4.2-29 summarizes the weight and power of the S-Band receiver assembly. Figure 4.2-30 summarizes the weight and power for the UHF and S-Band transmitters for the nominal performance situation. The power amplifier weight is not significant compared to filters and other transmitter elements. Figure 4.2-31 lists the transmitter power and weight estimates for Case D (nominal performance), Case D1 (+5 dB), and Case D2 (+10 dB). The total weight power summary for the three cases is given in Figure 4.2-32. The antennas and UHF assemblies are substantial contributors to the total weight, the switch matrix and the diplexing filters being the principle items. The matrix switch also is the significant contributor to the total power. Spacecraft weight and power are insensitive to variations in link performance because of the above considerations, e.g. the spacecraft weight varies only 3 percent over a 10 dB range in UHF link performance. Nevertheless, the Concept D spacecraft is very large.

| | QUANTITY | UNIT WT LBS | TOTAL WT LBS | TOTAL ECLIPSE POWER WATTS | TOTAL DAYTIME POWER WATTS |
|-----------------------------------|----------|----------------|-----------------|---------------------------------|------------------------------------|
| S-BAND RECEIVER | | | | | |
| POL SWITCH | 15 | 0.1 | 1.5 | | -- |
| INPUT/TRANSMIT REJ. FILTER | 15 | 1.8 | 27 | | -- |
| RING SWITCH | 38 | 0.2 | 7.6 | | -- |
| LNA | 19 | 1.2 | 22.8 | 15 | 15 |
| CONVERTERS | 19 | 0.5 | 9.5 | | -- |
| IFA | 19 | 1.0 | 19.0 | 22.5 | 22.5 |
| ATTENUATORS | 19 | 0.1 | 1.9 | | -- |
| CHANNELIZATION DIVIDER/ SUMMER | 30 | 0.1 | 3.0 | | -- |
| LO & SWITCHING | 4 + 4 | 1.9 | 15.2 | 12 | 12 |
| CHANNELIZATION UNITS | 3000 | 0.05 | 150 | 300 | 300 |
| CABLES & WAVEGUIDES | 1 SET | 8 | 8 | | -- |
| MISC & CONTINGENCY | | | 26.6 | 35 | 35 |
| SUBTOTAL | | | 292 LBS | 384WATTS | 384 WATTS |

Figure 4.2-29. Concept D S-Band Receiver Weight and Power

| | QUANTITY | UNIT WT LBS | TOTAL WT LBS | TOTAL ECLIPSE POWER WATTS | TOTAL DAYTIME POWER WATTS |
|---------------------|----------|----------------|-----------------|---------------------------------|------------------------------------|
| UHF TRANSMITTERS | | | | | |
| RING SWITCHES | 252 | 0.2 | 50.4 | -- | -- |
| ATTENUATORS | 125 | 0.1 | 12.5 | -- | -- |
| IFA | 125 | 1.0 | 125 | 150 | 150 |
| UPCONVERTER | 125 | 0.5 | 62.5 | -- | -- |
| LO'S & SWITCHING | 4 + 4 | 1.9 | 15.2 | 24 | 24 |
| PA | 125 | 0.75 | 93.8 | 75 | 75 |
| DIPLEXER | 100 | 5.4 | 540 | -- | -- |
| NOTCH FILTER | 100 | 5.4 | 540 | -- | -- |
| CABLES & WAVEGUIDE | | | | -- | -- |
| MISC. & CONTINGENCY | 1 SET | 50 | 160 | 25 | 25 |
| SUBTOTAL | | | 1756 LBS | 274 WATTS | 274 WATTS |
| S-BAND TRANSMITTERS | | | | | |
| RING SWITCHES | 38 | 0.2 | 7.6 | -- | -- |
| UPCONVERTER | 19 | 0.5 | 9.5 | -- | -- |
| ATTENUATOR | 19 | 0.1 | 1.9 | -- | -- |
| IFA | 19 | 1.0 | 19.0 | 22.5 | 22.5 |
| LO'S & SWITCHING | 4 + 4 | 1.9 | 15.2 | 24 | 24 |
| PA | 19 | 0.6 | 11.4 | 22 | 22 |
| DIPLEXER | 15 | 1.8 | 27.0 | -- | -- |
| NOTCH FILTER | 15 | 1.8 | 27.0 | -- | -- |
| CABLES & WAVEGUIDE | | | | -- | -- |
| MISC. & CONTINGENCY | 1 SET | 16 | 16 | 6.9 | 6.9 |
| SUBTOTAL | | | 157 LBS | 75 WATTS | 75 WATTS |

Figure 4.2-30. Concept D Transmitter Weight and Power

CASE D

UHF GAIN = 51.9 dBi PEAK, 49.9 dBi AVERAGE

$$P(\text{UHF}) = 23.9 + 2 + 10 \text{ LOG } 2.5/15\text{K} - 49.9 - 4 = -5.78 \text{ dBw} \rightarrow 0.264 \text{ WATTS}$$

$$P_{\mu}(\text{DC}) = 100 \times 0.264/0.35 = 75 \text{ WATTS}$$

$$U(\text{UHF}) = 0.75 + 0.25 \cdot 0.264/50 = 0.75 \text{ LBS}$$

CASE D1 (+ 5 dB)

$$P(\text{UHF}) = 28.9 + 2 + 22.2 - 49.9 - 4 = -0.78 \text{ (0.84 WATTS)}$$

$$P_{\mu}(\text{DC}) = 100 \times 0.84/0.35 \times 1.1 = 263 \text{ WATTS}$$

$$W(\text{UHF}) = 0.75 + 0.25 \cdot 0.84/50 = 0.75 \text{ LBS}$$

CASE D2 (+ 10 dB)

$$P(\text{UHF}) = 4.22 \text{ dBw (2.6 WATTS)}$$

$$P_{\mu}(\text{DC}) = 100 \times 2.6/0.35 = 817 \text{ WATTS}$$

$$W(\text{UHF}) = 0.75 + 0.24 \cdot 2.6/50 = 0.76 \text{ LBS}$$

Figure 4.2-31. Concept D Transmitter Weight and Power Estimates

| | WEIGHT (LBS) | | | POWER (WATTS) | | |
|---------------------------|--------------|-----------|-----------|---------------|------------|------------|
| | D | D1 | D2 | D | D1 | D2 |
| ANTENNA ASSEMBLY | 1110 | 1110 | 1110 | 0 | 0 | 0 |
| JHF RECEIVER ASS'Y | 2191 | 2191 | 2191 | 7900 | 7900 | 7900 |
| S-BAND TRANSMITTER ASS'Y | 292 | 292 | 292 | 384 | 384 | 384 |
| UHF TRANSMITTER ASS'Y | 1756 | 1756 | 1757 | 274 | 462 | 1016 |
| S-BAND TRANSMITTER ASS'Y | 157 | 157 | 157 | 75 | 75 | 75 |
| HOUSEKEEPING | -- | -- | -- | 400 | 400 | 400 |
| SUBTOTAL | 5506 LBS | 5506 LBS | 5507 LBS | 9033 WATTS | 9221 WATTS | 9775 WATTS |
| α_A (WATTS/LB) | | | | 13 | 13 | 13 |
| α_B (WATTS/LB) | | | | 7 | 7 | 7 |
| ARRAY WEIGHT, LBS | | | | 695 | 709 | 752 |
| BATTERY WEIGHT, LBS | | | | 1290 | 1317 | 1396 |
| TOTAL PAYLOAD WEIGHT, LBS | 7491 LBS | 7532 LBS | 7655 LBS | | | |
| TOTAL SPACECRAFT WT, LBS | 16647 LBS | 16738 LBS | 17011 LBS | | | |

Figure 4.2-32. Concept D Weight-Power Summary

4.2.5 CONCEPT D'

4.2.5.1 Introduction

Concept D, based on 100 UHF and 15 S-Band beams requires on-board switching (with concomitant, substantial weight and power), because of the lack of bandwidth at S-Band. This is, of course, a fundamental limitation of S-Band. An alternative is to use Ku-Band; since the required bandwidth $2.5 \text{ MHz} \times 100 = 250 \text{ MHz}$, Ku Band is more than adequate. Ku-Band is preferred over C-Band because Ku-Band avoids the C-Band orbital congestion, requires little frequency coordination for earth stations, and because small low cost 3 meter antenna systems, without tracking can be used. Fading is encountered, however .999 availability at Ku-Band is achievable at 14 and 12 GHz with fixed margins of approximately 15 dB and 5 dB, adequate for all but the southeast. Power diversity e.g. adaptation to a fade by increasing power, is probably not required in the UHF to Ku-Band link because a simple fixed margin of 5 dB should suffice. In the Ku-Band to UHF link, the gateway HPA can be designed to compensate for the uplink fade by noting the fading on the downlink, constant eirp, common signalling channel(s), and increasing the HPA drive accordingly. Typical gateway/satellite link performance is described in Table 4.2-2. The nominal, unfaded 15 KHz carrier power at the gateway terminal antenna is .44 watts. Considering 2 dB transmission loss, and 10 channels with 10 dB fade margin the required power is 44 watts - not believed to be overly expensive for a 10 trunk gateway. The downlink includes a 5 dB fixed margin resulting in a total fade of 6.9 dB.

4.2.5.2 Frequency Plan, Beam Plan and Capacity

Concept D' frequency plan is given in Figure 4.2-33. The total capacity is the same as for concept D, e.g. 250 MHz or 16667 15 KHz trunks or 62500 4 KHz trunks. The UHF beam plan is the same as Concept D, and, of course, a single Ku-Band beam illuminates CONUS, (plus spots for offshore coverage).

4.2.5.3 Transponder Arrangement

The transponder arrangement is identical to that of Concept B (12 UHF beams, 1 S-Band beam) except for the 100 UHF beams and the use of Ku-Band instead of S-Band. Figure 4.2-34 depicts the arrangement.

Table 4.2-2. Nominal Satellite/Gateway Link Performance for Concept D'

| | GATEWAY TO SATELLITE | SATELLITE TO GATEWAY |
|-------------------------------------|----------------------|----------------------|
| FREQUENCY | 14250 MHz | 11950 MHz |
| EIRP/CARRIER * | 46.6 dBw | 17.1 dBw |
| SPREADING LOSS (LOCAL VERTICAL), dB | -206.6 | -205.1 |
| NOMINAL GEOMETRIC FACTOR, dB | -0.5 | -0.5 |
| MISC. PROPAGATION FACTORS | -0.5 | -5.0 |
| FADE SKY NOISE INCREASE, dB | -- | -1.9 |
| ANTENNA GAIN, MIN, dBi | 28 | 50.1 |
| RECEIVED SIGNAL LEVEL, dBw | -133 | -145.3 |
| NOMINAL NOISE TEMPERATURE**, dB K | 28.0 (635°K) | 25.7 (370 K) |
| G/T dBi/K | 0 | 24.4 |
| CNo dB Hz | 67.6 | 57.6 |

* 3 METER ANTENNA, G = 50.1 dBi OR 0.44 WATTS PER CARRIER

** NF = 3 dB, 0.4 dB LOSS

4.2.5.4 Signalling, Switching and Network Control

The operational features are the same as for Concept B except for the implication of Ku-Band operation versus S-Band operation which principally concerns the dual level operation of the gateway HPA to compensate for uplink fading. While the signal levels required are locally generated it is believed that the elevated HPA level should have NOC concurrence via the signalling

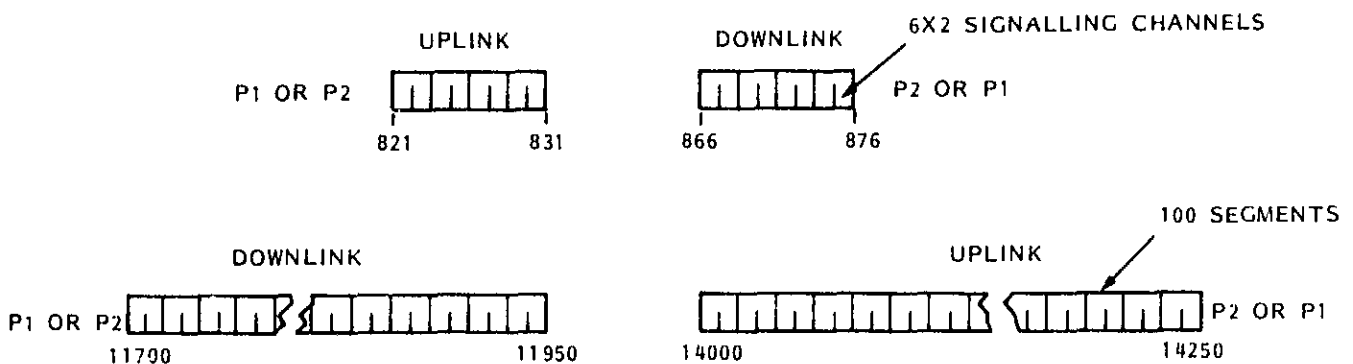

Figure 4.2-33. Concept D' Frequency Plan

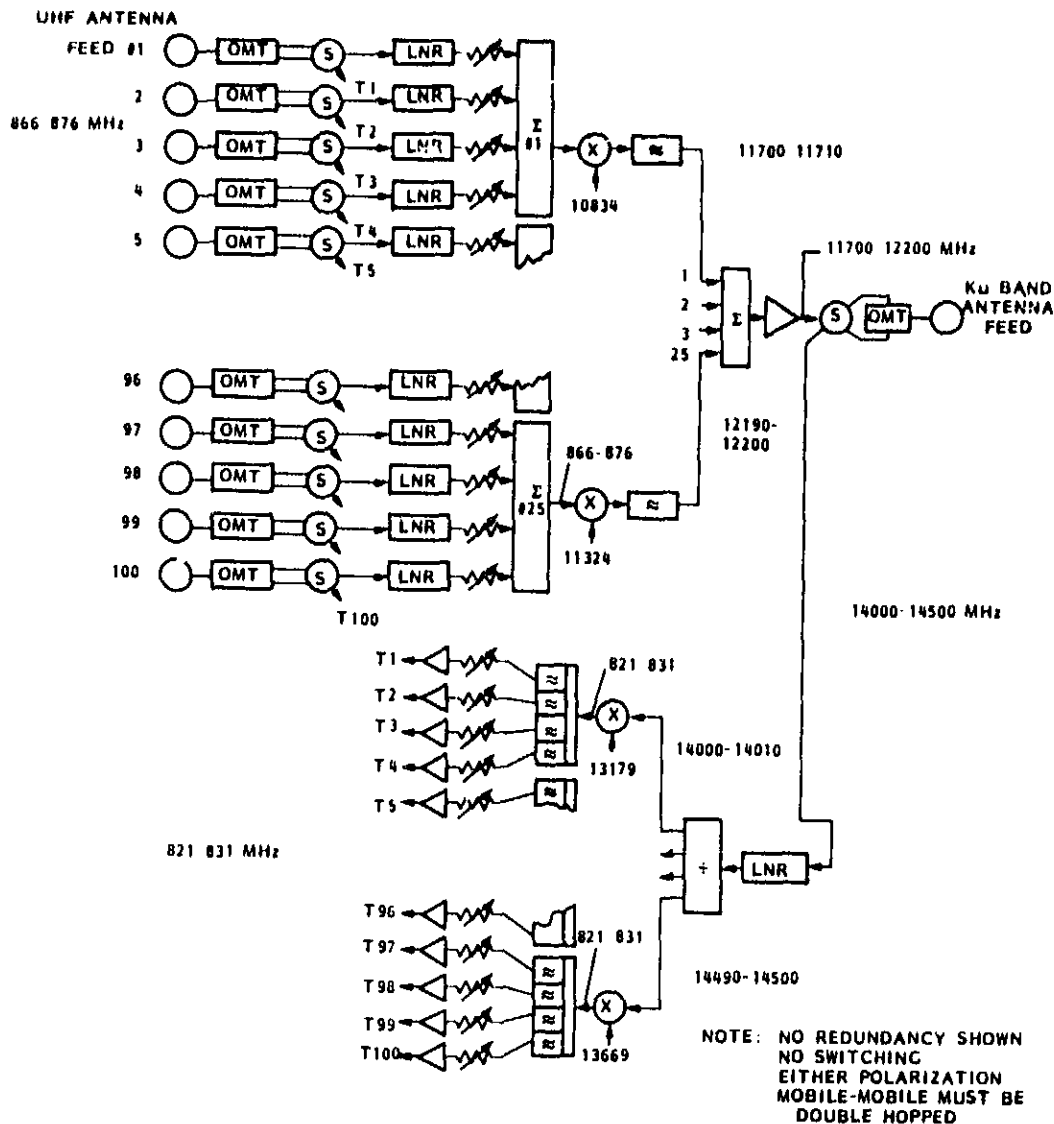

Figure 4.2-34. Concept D' Transponder Concept

system to avoid capricious or mistaken interpretation of the fading conditions (a momentary accidental reduction in the signalling channel level caused by the NOC causes the whole network to increase HPA levels.) The NOC concurrence prevents this. The gateway, of course, operates at Ku-Band and UHF, its block diagram is the same as Figure 4.2-14 if Ku-Band is substituted for S-Band.

4.2.5.5 Weight and Power Summary

Figure 4.2-35 gives the weight and power summary for the antenna and receiver subsystems. Principle weight items are the UHF antenna and filters. Figure 4.2-36 depicts a block diagram of the Ku-Band transmitter assembly starting with the UHF "summers", each of which adds the inputs of four UHF receive beam signals. These are, in turn translated into the 11.7 to 12.2 GHz band to form

a contiguous spectrum to each of the five Ku-Band "summers", each containing 50 MHz of the 250 MHz spectrum. Each 50 MHz spectrum is amplified by one Ku-Band amplifier, in a 9/5 redundancy scheme, after which, the Ku-Band amplifiers are multiplexed to form a continuous 250 MHz spectrum to be applied to the Ku-Band antenna. The Ku-Band receiver is similar to the single beam S-Band arrangement of Concepts B and C. Figure 4.2-37 summarizes the UHF and Ku-Band transmitter assembly weight and power. Figure 4.2-38 presents total weight and power for Concept D', D'1 (+5 dB UHF power) and D'2 (+10 dB UHF power). A 10 dB increase in UHF power increases spacecraft weight only 2%.

| | QUANTITY | UNIT WT LBS | TOTAL WT LBS | TOTAL ECLIPSE POWER WATTS | TOTAL DAYTIME POWER WATTS |
|----------------------------------|----------|----------------|-----------------|---------------------------------|------------------------------------|
| ANTENNA ASSEMBLY | | | | | |
| UHF REFLECTOR | 1 | 852 | 852 | -- | -- |
| UHF FEED ASS'Y | 100 | 0.2 | 20 | -- | -- |
| Ku BAND REFLECTOR | 1 (4') | 6.3 | 6.3 | -- | -- |
| Ku BAND FEED ASS'Y | 10 | 0.1 | 1.0 | -- | -- |
| OMT'S | 101 | 0.1 | 10.1 | -- | -- |
| SUPPORT & DEPLOYMENT | | | 91 | -- | -- |
| MISC/CONTINGENCY | | | 98 | | |
| SUBTOTAL | | | 1078 LBS | 0 | 0 |
| UHF RECEIVER | | | | | |
| POL SWITCH | 100 | 0.1 | 10.0 | -- | -- |
| INPUT/TRANSMIT REJ FILTER | 100 | 5.4 | 540.0 | -- | -- |
| RING SWITCH | 250 | 0.2 | 50.0 | -- | -- |
| LNA | 125 | 1.0 | 125.0 | 100 | 100 |
| IFA | 125 | 1.0 | 125.0 | 150 | 150 |
| ATTENUATOR | 125 | 0.1 | 12.5 | 0 | 0 |
| SUMMER | 25 | 1.0 | 2.5 | -- | -- |
| CABLES & WAVEGUIDE | 1 SET | 50 | 50 | -- | -- |
| MISC/CONTINGENCY | -- | -- | 91.4 | 15 | 15 |
| SUBTOTAL | | | 1006 LBS | 265 WATTS | 265 WATTS |
| Ku-BAND RECEIVER ASSEMBLY | | | | | |
| POL SWITCH | 1 | 1.25 | 1.25 | -- | -- |
| INPUT FILTER | 1 | 0.5 | 0.5 | -- | -- |
| LNR | 2 | 1.5 | 3.0 | 1.0 | 1.0 |
| IFA | 2 | 1.0 | 2.0 | 1.5 | 1.5 |
| SWITCHES, RECEIVER | 1 SET | 1.35 | 1.35 | -- | -- |
| DIVIDER | 1 | 1.0 | 1.0 | -- | -- |
| RING SWITCHES | 70 | 0.3 | 21.0 | -- | -- |
| CONVERTERS | 35 | 0.5 | 17.5 | -- | -- |
| LO'S | 50 | 1.5 | 75.0 | 75 | 75 |
| CHANNEL FILTER'S UHF | 100 | 7.3 | 730.0 | -- | -- |
| CABLES & WAVEGUIDE | 1 SET | 0.5 | 0.5 | -- | -- |
| MISC. & CONTINGENCY | -- | -- | 85.3 | 7.8 | 7.8 |
| SUBTOTAL | | | 938 LBS | 85.3 WATTS | 85.3 WATTS |

Figure 4.2-35. Concept D' Antenna and Receiver Weight and Power

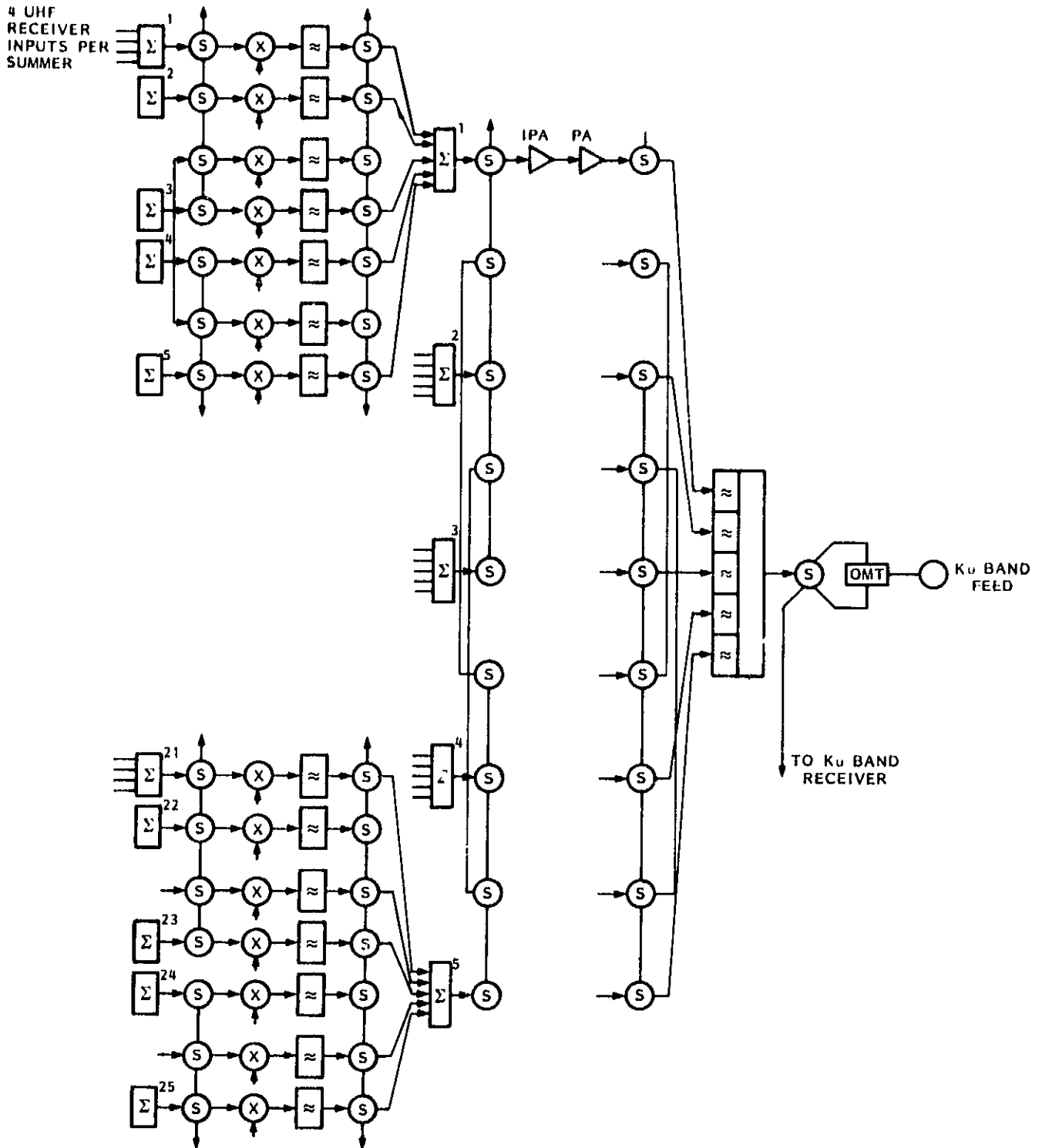

Figure 4.2-36. Concept D' Ku Band Transmitter Assembly

| | QUANTITY | UNIT WT LBS | TOTAL WT LBS | TOTAL ECLIPSE POWER WATTS | TOTAL DAYTIME POWER WATTS |
|----------------------------------|----------|----------------|-------------------|---------------------------------|------------------------------------|
| UHF TRANSMITTER ASSEMBLY | | | | | |
| RING SWITCHES | 252 | 0.2 | 50.4 | -- | -- |
| ATTENUATOR | 125 | 0.1 | 12.5 | -- | -- |
| IFA | 125 | 1.0 | 125.0 | 150 | 150 |
| PA | 125 | 0.75 | 93.8 | 19 | 74 |
| DIPLEXER | 100 | 5.4 | 540 | -- | -- |
| NOTCH FILTER | 100 | 5.4 | 540 | -- | -- |
| CABLES & WAVEGUIDE | 1 SET | 50 | 50 | -- | -- |
| MISC. & CONTINGENCY | | | 144.3 | 16.9 | 22.4 |
| SUBTOTAL | | | 1587.2 LBS | 186 WATTS | 246 WATTS |
| Ku BAND TRANSMITTER ASS'Y | | | | | |
| RING SWITCHES (CONVERTER) | 70 | 0.5 | 35.0 | -- | -- |
| UPCONVERTERS | 35 | 0.5 | 17.0 | -- | -- |
| LO'S | 50 | 1.5 | 75.0 | 75 | 75 |
| SWITCHES (AMPLIFIERS) | 18 | 1.25 | 22.5 | -- | -- |
| MUX | 1 | 10.0 | 10.0 | -- | -- |
| PA (TWTA, + ϕ + ARC) | 9 | 18 | 162 | 707 | 2122 |
| IPA | 9 | 2 | 18 | 25 | 25 |
| SUMMERS | 5 | 0.1 | 0.5 | -- | -- |
| CABLES & WAVEGUIDE | 1 SET | 1.0 | 1.0 | -- | -- |
| MISC & CONTINGENCY | | | 34.2 | 81 | 222 |
| SUBTOTAL | | | 376 LBS | 888 WATTS | 2444 WATTS |

UHF PA

$$P_u = +23.9 + 2 + 10 \text{ LOG } 2.5\text{M}/15\text{K} = 49.9 - 4 = 5.8 \text{ dBw (0.26 WATTS)}$$

$$P_u(\text{DC}) = 100 \times 0.26 / 0.35 = 74 \text{ WATTS}$$

$$\text{WT} = 0.75 + 0.25 \times 0.26 / 50 = 0.75$$

Ku BAND PA

$$P_u = +17.1 + 2.5 + 10 \text{ LOG } 250\text{M}/15\text{K} = 28 - 4 = 29.8 \text{ dBw (954 WATTS)}$$

$$5 \text{ 191 WATT TWT'S IN PARALLEL } P_{DC} = 5 \times 191 / 0.5 \times 0.9 = 2122$$

$$3 = 0.85 \times 0.5 = 0.425$$

$$P_{DC} = 1628$$

* 1/3 POWER DURING ECLIPSE LIKE "

Figure 4.2-37. Concept D' Transmitter Weight and Power

CASE 1 (D1)

$P_{\mu} = 0.8$ WATTS, $P = 94$ WATTS
 P_{μ} (DC) = $100 \times 0.8/0.35 \times 1.1 = 252$ WATTS
 $W(UHF) = 0.75 + 0.25 \times 0.8/50 = 0.75$ LBS

CASE 2 (D2)

$P_{\mu} = 2.6$ WATTS
 P_{μ} (DC) = $100 \times 2.6/0.35 \times 1.1 = 817$ WATTS
 $W_{\mu} = 0.75 + 0.25 \times 2.6/50 = 0.76$ LBS

| | WEIGHT (LBS) | | | POWER (WATTS) | | |
|------------------|--------------|----------|----------|-----------------|-----------------|-----------------|
| | D0 | D1 | D2 | D0 | D1 | D2 |
| ANTENNA ASSEMBLY | 1078 | 1078 | 1078 | 0 | 0 | 0 |
| UHF Rx ASS'Y | 1006 | 1006 | 1006 | 265/265 | 265/265 | 265/265 |
| K μ Rx ASS'Y | 938 | 938 | 938 | 85/85 | 85/85 | 85/85 |
| UHF Tx ASS'Y | 1587 | 1587 | 1587 | 246/186 | 424/230 | 989/371 |
| K μ Tx ASS'Y | 386 | 396 | 386 | 1628/680 | 1628/680 | 1628/680 |
| HOUSEKEEPING | 4995 LBS | 4995 LBS | 4995 LBS | 400/400 | 400/400 | 400/400 |
| SUBTOTAL | 4995 LBS | 4995 LBS | 4995 LBS | 2624/1616 WATTS | 2802/1660 WATTS | 3367/1807 WATTS |
| α_A | -- | -- | -- | 8.3 | 8.3 | 8.7 |
| α_B | -- | -- | -- | 7 | 7 | 7 |

| | | | |
|----------------------------|-----------|-----------|-----------|
| ARRAY WEIGHT | 316 | 330 | 387 |
| BATTERY WEIGHT | 231 | 237 | 257 |
| TOTAL PAYLOAD | 5542 LBS | 5562 LBS | 5639 LBS |
| TOTAL S/C ($\mu = 0.45$) | 12316 LBS | 12360 LBS | 12531 LBS |

Figure 4.2-38. Concept D' Weight and Power Summary

4.2.6 SUMMARY OF CONCEPTS

A summary of satellite concepts is presented in Figure 4.2-39. UHF power requirements for all FDMA concepts are quite modest compared to spacecraft complexity and weight. The SS-FDMA channelization switch weight and power makes this spacecraft singular in its spacecraft weight and power.

| CONCEPT | NO. OF UHF BEAMS | NO. OF FS BEAMS | TOTAL BANDWIDTH* MHz | UHF TRANSMIT POWER PER BEAM WATTS | FS TRANSMIT POWER PER BEAM WATTS | ROUTING CONCEPT | SPACECRAFT WEIGHT LBS | SPACECRAFT POWER WATTS |
|---------|------------------|-----------------|----------------------|-----------------------------------|----------------------------------|-----------------|-----------------------|------------------------|
| A | 1 | 1 | 10 | 1/4 | 3.5 | FDMA | 593 | 767 |
| A1 | 1 | 1 | 10 | 550 | 3.5 | FDMA | 1,012 | 1,948 |
| A2 | 1 | 1 | 10 | 1,738 | 3.5 | FDMA | 2,053 | 5,682 |
| B | 12 | 1 | 30 | 3.5 | 8.3 | FDMA | 1,798 | 540 |
| B1 | 12 | 1 | 30 | 11.2 | 8.3 | FDMA | 1,913 | 844 |
| B2 | 12 | 1 | 30 | 35.5 | 8.3 | FDMA | 2,051 | 1,059 |
| C | 31 | 1 | 77.5 | 1.2 | 21.4 | FDMA | 3,422 | 687 |
| C1 | 31 | 1 | 77.5 | 3.9 | 21.4 | FDMA | 3,524 | 961 |
| C2 | 31 | 1 | 77.5 | 12.4 | 21.4 | FDMA | 3,809 | 1,789 |
| D | 100 | 15 | 250 | 0.26 | 0.44 | SS-FDMA | 16,647 | 9,033 |
| D1 | 100 | 15 | 250 | 0.84 | 0.44 | SS-FDMA | 16,738 | 9,221 |
| D2 | 100 | 15 | 250 | 2.6 | 0.44 | SS-FDMA | 17,011 | 9,775 |
| D' | 100 | 1 | 250 | 0.26 | 954 | FDMA | 12,316 | 2,624 |
| D'1 | 100 | 1 | 250 | 0.84 | 954 | FDMA | 12,360 | 2,802 |
| D'2 | 100 | 1 | 250 | 2.6 | 954 | FDMA | 12,531 | 3,367 |

* PER SATELLITE

Figure 4.2-39. Summary of Concept Characteristics

REFERENCES

1. Customers Premise Service Study, Final Report, 1982 by GE. NASA Lewis Research Center, Contract NAS3-2289.
2. Study of Advanced Communication Satellite Systems based on SS-FDMA, 1980, by GE. NASA Lewis Research center Contract NAS3-21745.

4.3 SPACE SYSTEM INVESTMENT

4.3 SPACE SYSTEM INVESTMENT

4.3.1 COST ANALYSIS

4.3.1.1 Approach

The Land Mobile Satellite System costing involves three separate entities, the space segment, (including satellites, launch vehicles, control center, insurance and O&M),, the gateways, and the mobiles. It is useful to treat these separately not only to simplify the comparisons with the all-terrestrial system but because the economic motives for the three are quite different; for example, each of these entities has different owners. The satellite is owned and operated by a satellite carrier. The gateways can also be owned by the same carrier or more likely by a local operator, a wireline or radio carrier, a government agency or a company. The mobiles can be owned by individual subscribers (or leased to them), as is the case for radio telephone, or owned by a corporation or government agency. Each of these has his own economic motives and each has his own performance objectives.

In this study the space segment costing methodology is based on first defining various satellite concepts capable of satisfying the postulated market and service demand, estimating their performance characteristics and thence weight and power which in turn enables a cost estimate to be developed for each concept. Satellite costs plus other costs such as for launch vehicles, insurance, control center, various services etc. are then added together to obtain the space segment investment. By dividing this investment by the satellite nominal capacity the investment per standard equivalent trunk is obtained. The standard equivalent trunk is defined as compandored SSB using 4 kHz bandwidth for the nominal performance case. The investment per trunk is parametric with regard to the beam fill, the various satellite concepts defined and the three levels of performance. Later, by estimating the number of subscribers per standard equivalent trunk for the various services contemplated, the total investment can be obtained for comparison with the terrestrial system.

The investment also can be converted into a periodic subscriber charge by considering a depreciation period, depreciation, expense, taxes, return on investment and interest, as well as the subscriber service demand and service characteristic. This can be accomplished for various grades of service,

service mixes, peak to average factors and mobile G/T, which also can be compared with the terrestrial system.

A sketch of this methodology is depicted in Figure 4.3-1, which describes a two-step process. In the first step, the "initial cost tradeoffs", the total space system investment is computed, this provides an "intermediate" parametric output of investment and periodic charges, for standard equivalent (4 kHz) trunks. In the second step these are converted into parametric annual or monthly charges for the various services. The results provide a variety of financial "yardsticks" with which to compare the terrestrial and satellite systems, which will identify the areas, circumstances and services for which one is better, compared to the other.

Gateway costs also are estimated by similar methodology. In this case comparisons are made between operator owned gateways and alternative methods of providing service to the operator's region (such as TELCO dial-up or leased lines, or radio relays), as a function of the total demand load. The costs of the various alternatives are first computed, and then analyzed using total demand as an independent variable. It is interesting to note that the operators can have varying motives with regard to system design. For example he may wish to minimize his gateway cost by minimizing the number of channel units thereby degrading the grade of service. On the other hand, an operator providing an end to end radio telephone service may require a good grade of service from his gateway in order to meet good end-to-end service requirements. Gateway costs are computed in Section 4.5.

Finally, the mobile units are estimated, primarily by comparing the mobile equipment characteristics for the satellite and terrestrial systems, for the various services. For example, there is a good deal of similarity in the equipment for dial-up voice and therefore costs should be the same except for difference in antenna designs, modulation, etc. Costs for the interactive data mobiles are obtained by comparing the functions provided, and the components required, with similar mass produced electronic equipment such as mobile equipment, and radios.

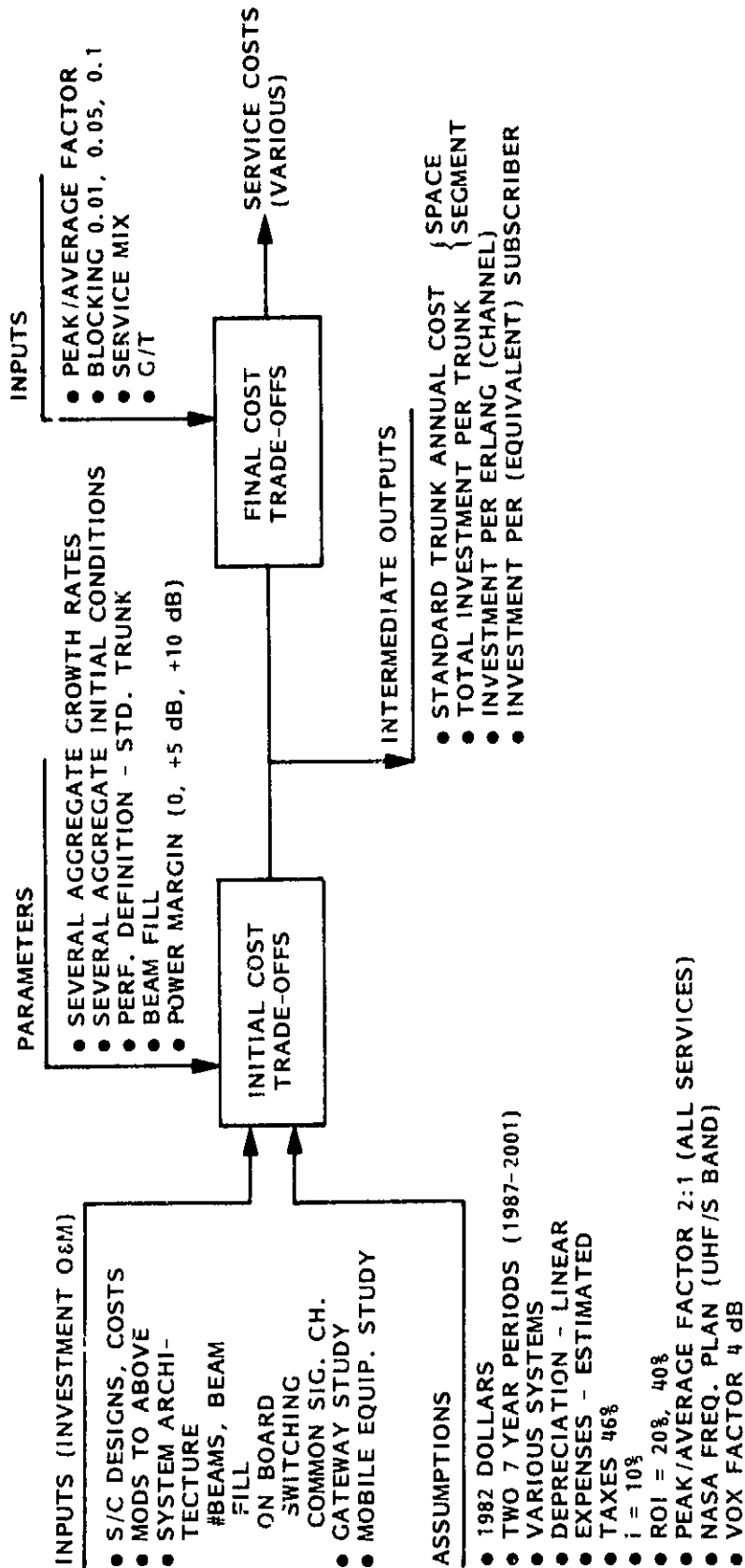

Figure 4.3-1. Cost Methodology

4.3.1.2 Limitations

Industry experience with land mobile satellite systems is inadequate to precisely define acquisition costs and therefore resort is made to estimation based on experience with fixed service satellites and similar systems. These extrapolations are believed to be sufficiently accurate for the study purposes although it should be realized that the mobile satellites, while containing the same components (antennas, transponders, attitude control, etc.) as those for the fixed services, also have significant differences. These are the larger antennas, higher power, more complex transponders and the impact of these on the other spacecraft systems. In addition, the large land mobile satellites are mission unique and therefore the non-recurring (design) costs are likely to be fully allocated to each particular version. In addition, there is an uncertainty in the performance achievable, and acceptable in the future land mobile satellite market. For example higher performance mobile antennas will reduce satellite charges, but increase mobile costs. Performance will vary due to the effect of shadowing, multipath and man made noise for different regions and minimum acceptable (usable) performance will certainly depend on the individual application and on the service. Recognizing these service uncertainties the study approach is to provide a measure of service performance vs cost so that performance cost sensitivities can be evaluated. It should be kept in mind that various existing mobile services performances are remarkably different in quality depending on the application, ranging from fairly high quality (but not toll quality) for radio telephone to almost total unintelligibility except to the trained user (air traffic controller). Consequently, it should be expected that a land mobile system also will have diversity in performance and availability.

The comparisons between the satellite and terrestrial systems are complicated by the diversity of these quality-cost considerations.

4.3.1.3 CAPACITY ASSUMPTIONS

Satellite capacity projections are required to size the various satellite concepts, and to indicate how the various satellite concepts can be used to provide service. Using the "Addressable Mobile Radio Market" developed in this Study as Task 1, a capacity demand versus time can be developed. Figure 4.3-2 lists the basic (or equivalent wideband data) traffic demand in erlangs developed from the number of mobiles in the "new services", "commercial and public radio services" and "radio telephone" services. It is assumed that the

radio telephone services use 15 kHz CFM which is converted into equivalent 4 kHz trunks which are used for the other services. The totals, in "conservative," "likely" and "optimistic" categories are provided vs time in terms of 4 kHz equivalent circuits.

The case for truck trailers and similar applications, involving the interactive data mode is treated differently. Assume each interactive data message consists of a 500 bit block(64 characters plus address and sync). BPSK data rate in a 4 kHz channel is approximately 3.1 KBPS. The actual rate is somewhat less, due to coding (rate 7/8), guard time between packets (.92), and an allowance (.9) for periodic "clear" times to permit alarms, for a total throughput rate of 2.23 KBPS. It is assumed that NOC interrogation results in TDM like efficiency (e.g., the network is polled only by the NOC). This results in 193,000 messages per 12 hour day. Consider also an average of two message per day and two trunks per message stream (mobile to NOC and thence NOC to operator, and reverse - omitting any efficiencies resulting from NOC culling or processing), This results in the ability to serve an average of 48168 mobiles per trunk per day. Of course, actual mobiles may have more than two messages per day (in this case a tractor also is likely to be in voice communication with a dispatcher) and an inactive truck may have fewer than two messages per day. Position location messages are interchangeable with interactive data. Table 4.3-1 describes the results.

| | 1990 | 1995 | 2000 |
|------------------------------------|--------|--------|--------|
| Trailers | 168439 | 185970 | 205326 |
| Required Number of 4 kHz trunks | 3.5 | 3.9 | 4.3 |

Note: The required numbers of trunks doubles, effectively, if the orthogonally polarized channel cannot be used because of poor mobile antenna circularity.

Table 4.3-1 Truck Trailer Trunk Requirements for Interactive Data and Position Location.

The results are miniscule compared to the voice and wideband data requirements. This is not to say that the service is not of importance in terms of value to the transportation industry (and for similar industry and government applications), or of value to the satellite carrier in terms of income. The converse is true.

SERVICE
BANDWIDTH
KHz

1990 1995 2000

NEW SERVICES (0.01 ERLANGS PER TRUCK)

TRUCK TRACTORS (1)
OIL & GAS

| | | | |
|------------|------------|------------|---|
| 869 | 959 | 1059 | 4 |
| <u>430</u> | <u>498</u> | <u>584</u> | |
| 1299 | 1457 | 1643 | |

COMMERCIAL & PUBLIC RADIO (0.01 ERLANGS PER MOBILE)

CONSERVATIVE
LIKELY
OPTIMISTIC

| | | | |
|------|-------|-------|---|
| 1113 | 1562 | 2190 | 4 |
| 4404 | 7093 | 11423 | 4 |
| 9760 | 15718 | 25314 | 4 |

RADIO TELEPHONE (0.03 ERLANGS PER MOBILE)

CONSERVATIVE
LIKELY
OPTIMISTIC
CONSERVATIVE
LIKELY
OPTIMISTIC } (2)

| | | | |
|-------|-------|-------|----|
| 1548 | 1975 | 2521 | 15 |
| 6507 | 9126 | 12800 | 15 |
| 8634 | 13906 | 19503 | 15 |
| 5805 | 7406 | 9454 | 4 |
| 24401 | 34223 | 48000 | 4 |
| 32378 | 52148 | 73136 | 4 |

TOTAL

CONSERVATIVE
LIKELY
OPTIMISTIC

| | | | |
|-------|-------|--------|---|
| 8217 | 10425 | 13287 | 4 |
| 30104 | 42773 | 61066 | 4 |
| 43437 | 69323 | 100093 | 4 |

(1) INTERACTIVE DATA DEMAND FOR TRUCK TRAILERS IS NEGLIGIBLE COMPARED TO VOICE TRAFFIC

(2) CONVERTED TO 4 KHz CHANNELS BY RATIO OF 15/4 = 3.75

Figure 4.3-2. Total Service Demand, Erlangs

The total market results for voice are depicted in Figure 4.3-3, for the conservative, likely and optimistic categories, versus time, in equivalent 4 kHz voice trunks. Figure 4.3-3 also indicates the ability of the various satellite concepts to satisfy the demand estimate. Also, Figure 4.3-3 contains an exponential growth relationship between initial and final capacity, growth rate and time, with tabulated parameters for the optimistic, likely and conservative cases. While Figure 4.3-3 assumes that only radio telephone uses 15 kHz CFM, this may not be the case in practice. Consequently, the plan is to examine several initial conditions and growth rates that describe typical situations representative of Figure 4.3-3, to develop costs as a function of growth rates and service mix.

100 BEAM SATELLITE SYSTEM(2) D, D'

C/D SATELLITE CAPACITY(2)

$C(t) = C_0 \frac{(1+r)^t}{(1+r)^T}$
 C(0) = INITIAL CAPACITY
 C₀ = FINAL CAPACITY
 r = GROWTH RATE
 t = TIME

| | OPTIMISTIC | LIKELY | CONSERVATIVE |
|----------------|------------|--------|--------------|
| C(0) | 28K | 22K | 7K |
| C ₀ | 110K | 65K | 13K |
| r | 0.1027 | 0.0805 | 0.0452 |

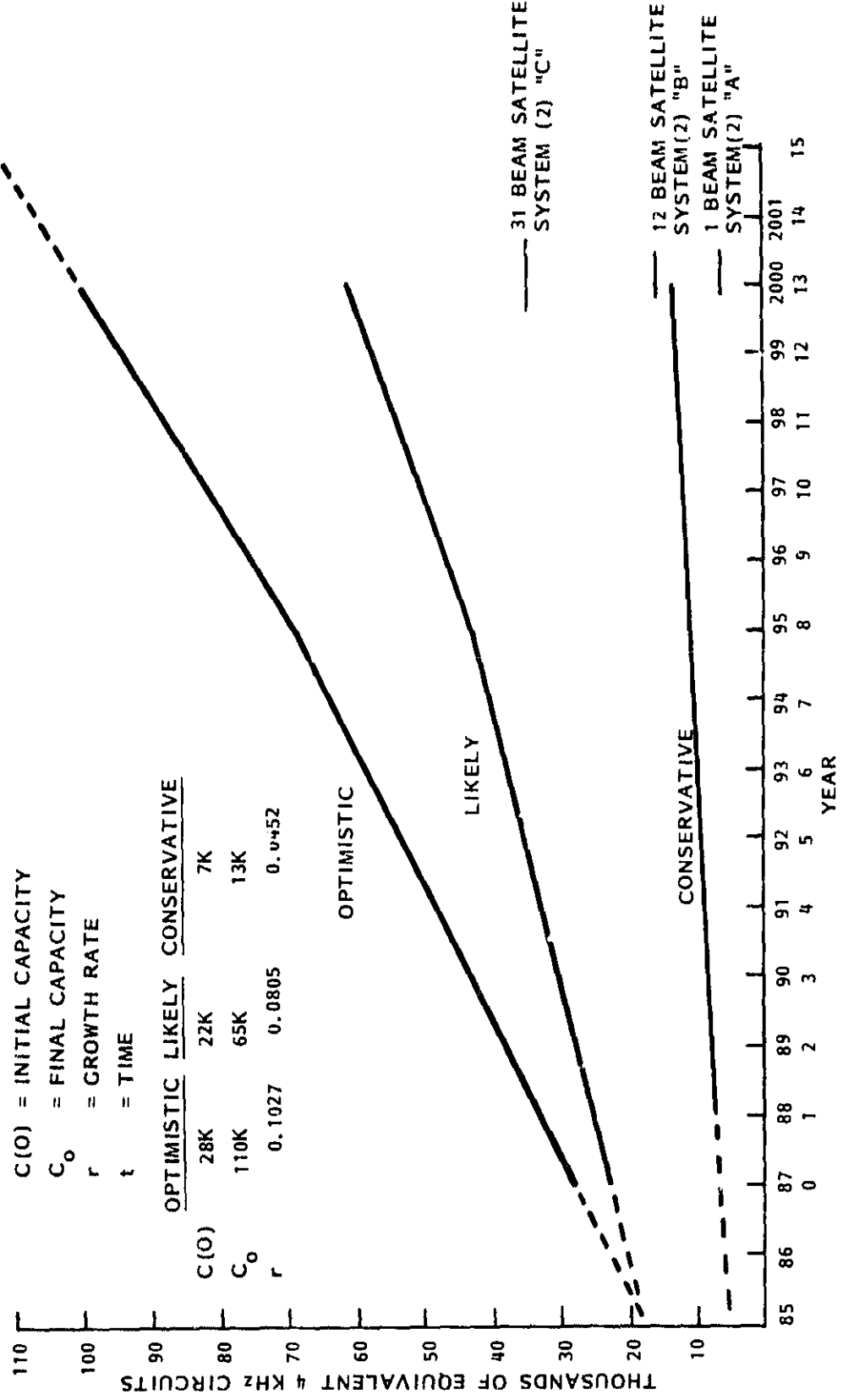

Figure 4.3-3. Total Market Projection (Equivalent 4 KHz Circuits)

4.3.2 SPACE SYSTEM COSTS

4.3.2.1 Investment

Satellite costs can be estimated according to the "Unmanned Spacecraft Cost Model", Fifth Edition (June 1981), otherwise referred to as the "SAMSO" model. This model uses historical cost data from the aerospace industry, from many available satellite programs, commercial and military, communications and others. It thus represents a general, composite cost estimate which is representative of the aerospace industry. The model provides both nonrecurring (design) and recurring cost, by subsystem. Factors can be included for maturity of design, design complexity and inflation. Design complexity factors include such items as operational life, radiation environment, redundancy, operating frequency, power, antenna complexity, stabilization type, etc.

While it is not intended to be valid for the very large spacecraft for land mobile communications (there are some small mobile satellites such as Marisat and Tacsat in the data base), the subsystem functional relationships, which relate subsystem cost to the weight and power (and complexity etc.) can be examined for relevance to a larger spacecraft, which is dissimilar to those in the data base. The approach has considerable merit for the following reasons.

1. A fairly detailed satellite concept must be developed for use with the model - this enables comparisons of various approaches, for example onboard switching at S-Band vs a Ku-Band fixed link.
2. The prediction is a "neutral" prediction (based on a widely used and accepted methodology) with an extensive, historical data base - not "colored" by the experience of one company.
3. The cost is "built up" subsystem by subsystem so that the detail is capable of individual tests for reasonableness.
4. The model is thoroughly documented, well understood, and widely accepted.

4.3.2.2 Bogey Weight Model

The SAMSO Model requires the weight and power of individual specific subsystems. The model, used for the Study and given in Table 4.3-2, describes the fractional weight distribution of a typical communications satellite compared to its beginning of life mass in synchronous orbit. The totals in

Table 4.3-2 do not include apogee motor case or fuel. The ratio of communications transponder, antennas and power subsystem weight to total beginning of life weight is = .43, typical of modern spacecraft (?). The actual weight for the communications and power system are computed in detail from the Concept Models. The total is assumed to represent 43% of the total spacecraft mass. One anomaly in particular was noted in connection with the nonrecurring cost of the electrical power system (EPS). This expression is of the form $a + b W^{.81}$, where w is the product of beginning of life power and subsystem weight. The expression results in reasonable cost predictions in the weight and power ranges specified by the SAMSO model. However it increases rapidly to unbelievable values at large powers, in the range of 5 kw, because it is really equivalent to P^2/C where P is the power and C the equivalent watts per pound for the system (more or less constant). It is believed that the nonrecurring cost is more or less proportional to the total power and this assumption was used for those cases (Concepts C, D, D¹); the relationship is, $\text{cost} = 3167 + 7.467P$.

In addition, the SAMSO model seems to result in high total nonrecurring costs compared with recent commercial experience. It is believed that an important consideration is that most modern commercial satellites follow "one from the other" so that nonrecurring costs are small (e.g., each system is derived in large part from its predecessor), and there is a tendency to spread these nonrecurring costs over several programs. It is not believed that this will be the case for the large, unique land mobile satellites. There will be nothing like them and therefore the entire nonrecurring cost is applied to each concept.

4.3.2.3 Concept Model Costs

Technology indices, essentially maturity of design are described in Table 4.3-3. Complexity factors for communications/antenna subsystems and power subsystem are described in Table 4.3-4 and complexity factors for structure/thermal, TT&C, and ACS/SPS are described in Table 4.3-5.

Tables 4.3-6 and 4.3-7 describe recurring and nonrecurring costs for Concept A, respectively. This is a single beam satellite, A1 has 5 dB more UHF power, and A2 10 dB more UHF power than A.

Table 4.3-2. Bogey Weight Model

| | |
|------------------------|--------------|
| COMMUNICATIONS/ANTENNA | 0.197 |
| ACS/SPS | 0.086 |
| TT&C | 0.03 |
| STRUCTURE/THERMAL | 0.162 |
| POWER | <u>0.232</u> |
| | 0.707 |
| $\mu = 458$ | |

Table 4.3-3. Technology Indices

| | | |
|----------------|-------|-------|
| | NRC | RC |
| STRUCTURE | 0.872 | 0.878 |
| TT&C | 0.831 | 0.834 |
| COMMUNICATIONS | 0.884 | 0.873 |
| ACS | 0.876 | 0.840 |
| EPS | 0.876 | 0.90 |

Table 4.3-4. Communications Power Complexity Factors

| COMMUNICATIONS | COMPLEX | NPC RANK | X | COMPLEX | RC RANK | X |
|----------------------------|---------|----------|---------------|---------|---------|---------------|
| FREQ, TRANS, POWER | 1.0 | 0.10 | 1.0 | 1.0 | 0.08 | 0.08 |
| NUMBER OF TRANSMITTERS | 1.4 | 0.05 | 0.07 | 1.37 | 0.05 | 0.685 |
| MOD METHOD | 1.0 | 0.02 | 0.02 | 1.0 | 0.02 | 0.02 |
| MUX | 1.14 | 0.05 | 0.057 | 1.1 | 0.05 | 0.055 |
| REDUNDANCY | 1.36 | 0.03 | 0.0408 | 1.30 | 0.03 | 0.039 |
| ON-BOARD PROCESSING | 1.0 | 0.16 | 0.16 | 1.0 | 0.16 | 0.16 |
| DATA RATE | 1.15 | 0.03 | 0.0345 | 1.13 | 0.03 | 0.0339 |
| BER | 1.03 | 0.03 | 0.0309 | 1.03 | 0.02 | 0.0206 |
| ENCRYPTION LEVEL | 1.0 | 0.03 | 0.03 | 1.0 | 0.03 | 0.03 |
| TYPE OF ANTENNA | 5.44 | 0.08 | 0.4352 | 5.4 | 0.09 | 0.486 |
| ANTENNA DESIGN | 7.9 | 0.11 | 0.869 | 8.0 | 0.10 | 0.8 |
| POWER HANDLING, CAPABILITY | 1.0 | 0.03 | 0.03 | 1.0 | 0.03 | 0.03 |
| AJ | 1.0 | 0.07 | 0.07 | 1.0 | 0.08 | 0.08 |
| DESIGN LIFE | 1.3 | 0.09 | 0.117 | 1.3 | 0.11 | 0.143 |
| HARDENING | 1.08 | 0.12 | <u>0.1296</u> | 1.08 | 0.12 | <u>0.1296</u> |
| | | | 3.094 | | | 2.1756 |
| <u>POWER SUBSYSTEM</u> | | | | | | |
| POWER DESIGN SHAPE | 1.25 | 0.22 | 0.275 | 1.39 | 0.19 | 0.2641 |
| DEGREE OF MOVEMENT | 1.14 | 0.14 | 0.1596 | 1.11 | 0.13 | 0.1443 |
| POWER | 1.45 | 0.24 | 0.348 | 4.63 | 0.21 | 0.9723 |
| BATTERIES | 1.43 | 0.14 | 0.2002 | 1.44 | 0.16 | 0.2304 |
| DESIGN LIFE | 1.22 | 0.15 | 0.183 | 1.16 | 0.20 | 0.232 |
| HARDENING | 1.0 | 0.11 | <u>0.11</u> | 1.01 | 0.11 | <u>0.1111</u> |
| | | | 1.2758 | | | 1.9542 |

Table 4.3-5. Spacecraft Bus Complexity Factors

| <u>STRUCTURE, THERMAL CONTROL & INTERSTAGE</u> | COMPLEX | NRC RANK | X | COMPLEX | RC RANK | X |
|--|---------|----------|--------------|---------|---------|---------------|
| STRUCTURE/COMPOSITES | 1.46 | 0.13 | 0.1898 | 1.51 | 0.16 | 0.2416 |
| DESIGN SHAPE | 1.30 | 0.12 | 0.156 | 1.30 | 0.12 | 0.24 |
| THERMAL CONTROL | 1.28 | 0.19 | 0.2432 | 1.37 | 0.18 | 0.2466 |
| STABILIZATION | 1.09 | 0.21 | 0.2289 | 1.10 | 0.24 | 0.264 |
| DESIGN LIFE | 1.19 | 0.12 | 0.1428 | 1.18 | 0.11 | 0.1298 |
| HARDENING | 1.07 | 0.10 | 0.107 | 1.08 | 0.10 | 0.108 |
| LAUNCH METHOD | 1.20 | 0.13 | <u>0.156</u> | 1.11 | 0.09 | <u>0.0999</u> |
| | | | 1.2237 | | | 1.302 |
| <u>TT&C</u> | | | | | | |
| ON BOARD DATA PROC. | 1.08 | 0.17 | 0.1836 | 1.08 | 0.18 | 0.1944 |
| DATA RATE | 1.03 | 0.08 | 0.0824 | 1.06 | 0.08 | 0.848 |
| NUMBER OF DISCRETE COMMANDS | 1.08 | 0.09 | 0.0972 | 1.12 | 0.10 | 0.112 |
| TYPE OF ELECTRONICS | 1.18 | 0.12 | 0.1416 | 1.20 | 0.12 | 0.144 |
| ENCRYPTION LEVEL | 1.0 | 0.04 | 0.04 | 1.0 | 0.04 | 0.04 |
| DEGREE OF AUTONOMY | 1.39 | 0.09 | 0.1251 | 1.25 | 0.09 | 0.1125 |
| TYPE OF MEMORY | 1.0 | 0.08 | 0.08 | 1.0 | 0.09 | 0.09 |
| DESIGN LIFE | 1.46 | 0.17 | 0.2482 | 1.42 | 0.16 | 0.2272 |
| HARDENING | 1.05 | 0.16 | <u>0.168</u> | 1.05 | 0.14 | <u>0.147</u> |
| | | | 1.1661 | | | 1.1519 |
| <u>ACS/SPS</u> | | | | | | |
| ATTITUDE CONTROL | 1.13 | 0.21 | 0.2373 | 1.12 | 0.22 | 0.2464 |
| STATIONKEEPING | 1.36 | 0.25 | 0.34 | 1.36 | 0.25 | 0.34 |
| POINTING ACCURACY | 1.28 | 0.23 | 0.2856 | 1.24 | 0.21 | 0.2604 |
| STABILIZATION | 1.23 | 0.11 | 0.1529 | 1.19 | 0.11 | 0.1309 |
| DESIGN LIFE | 1.28 | 0.12 | 0.1536 | 1.20 | 0.14 | 0.168 |
| HARDENING | 1.0 | 0.06 | <u>0.06</u> | 1.0 | 0.07 | <u>0.07</u> |
| | | | 1.236 | | | 1.2157 |

Table 4.3-6. Concept A Recurring Cost

| | COMPOSITE INDEX | | |
|---------------|-----------------|-------|-------|
| | A | A1 | A2 |
| COMM (LBS) | 114.4 | 118.2 | 130.1 |
| POWER (WATTS) | 767 | 1948 | 5682 |
| POWER (LBS) | 153 | 337 | 794 |
| TOTAL (LBS) | 593 | 1012 | 2053 |

Handwritten signature

| | | | | | |
|------------------------|-------|-------------------------------|--------------|--------------|--------------|
| STRUCTURE/THERMAL | 1.589 | $Y = 19.38X^{0.66}$ | 627 | 892 | 1422 |
| TT&C | 1.335 | $Y = 14.11 + 33.04X^{0.91}$ | 624 | 1004 | 1894 |
| COMM/ANT | 2.640 | $Y = 41.02X^{0.87}$ | 6690 | 6883 | 7482 |
| ACS/SPS | 1.419 | $Y = -103.17 + 34.93X^{0.76}$ | 837 | 1330 | 2382 |
| EPS | 2.445 | $Y = 72.42W^{0.27}$ | 4396 | 6588 | 11775 |
| AKM | | | <u>800</u> | <u>800</u> | <u>900</u> |
| SUBTOTAL | | | \$ 13,974 K | \$ 17,497 K | \$ 25,855 K |
| PROGRAM LEVEL (0.3291) | | | <u>4,599</u> | <u>5,758</u> | <u>8,509</u> |
| SUBTOTALS | | | 18,573 | 23,255 | 34,364 |
| FEE (15%) | | | <u>2,786</u> | <u>3,488</u> | <u>5,155</u> |
| TOTAL | | | \$ 21,359 K | \$ 26,744 K | \$ 39,518 K |

$W = W_{PS} \times P_{PS} \times 1.25$

Table 4.3-7. Concept A Nonrecurring Cost

| | COMPOSITE INDEX | | |
|---------------|-----------------|-------|-------|
| | A | A1 | A2 |
| COMM (LBS) | 114.4 | 118.2 | 130.1 |
| POWER (WATTS) | 767 | 1,948 | 5,682 |
| POWER (LBS) | 153 | 337 | 794 |
| TOTAL (LBS) | 593 | 1,012 | 2,053 |

| | | | | | |
|------------------------|-------|---------------------------------|-------------|-------------|--------------|
| STRUCTURE/THERMAL | 1.347 | $Y = 1098.18 + 90.39X^{0.67}$ | \$ 4,090 | \$ 5,214 | \$ 7,478 |
| TT&C | 2.32 | $Y = 705.23 + 34.80X$ | 3,072 | 4,087 | 6,609 |
| COMM/ANT | 3.802 | $Y = 468.67X^{0.57}$ | 26,557 | 27,056 | 28,577 |
| ACS/SPS | 2.454 | $Y = 372.82 + 27.92X$ | 4,409 | 6,878 | 13,012 |
| EPS | 2.493 | $Y = 2098.95 + 0.03401W^{0.93}$ | 10,641 | 15,951 | 45,594* |
| SUBTOTAL | | | \$ 48,769 K | \$ 59,226 K | \$ 101,270 K |
| PROGRAM LEVEL (0.3568) | | | 17,401 | 21,132 | 36,133 |
| SUBTOTAL | | | 66,170 | 80,358 | 137,403 |
| FEE (15%) | | | 9,925 | 12,054 | 20,610 |
| TOTAL | | | \$ 76,095 K | \$ 92,412 K | \$ 158,014 K |

$$W = W_{PS} \times P_{PS} \times 1.25$$

* MODIFIED SAMSO

It is interesting to note that the results are typical of modern communications satellite experience. A modern PAM-D satellite has a typical mass of 1500 lbs and its cost is in the range between A1 and A2. The nonrecurring costs are high, principally for the reasons noted previously. However Concept A is similar to a recent GE satellite system implementation and the Concept A costs, including recurring and nonrecurring are close to the total for the GE program. The nonrecurring EPS cost is revised for A2 as previously explained.

Concept B, a 12 beam satellite, has a weight for nominal performance of only 1798 pounds, despite the deployment of the large antenna. Recurring and nonrecurring costs are given in Tables 4.3-8 and 4.3-9 respectively.

Concept C recurring and nonrecurring costs are given in Tables 4.3-10 and 4.3-11 respectively. The EPS nonrecurring cost for C2 is modified as explained previously.

Concept D' is a 100 beam satellite with a single Ku-Band fixed beam, and no onboard switching. Recurring and nonrecurring costs are given in Tables 4.3-12 and 4.3-13 respectively. The high Ku-Band power requires modification of EPS nonrecurring costs as previously explained.

Concept D is a 100 UHF beam satellite with 15 S-Band beams and extensive onboard channelization and switching resulting in large weight and high power. Tables 4.3-14 and 4.3-15 describe the recurring and nonrecurring costs respectively. Again the EPS nonrecurring cost is computed as explained previously.

Nonrecurring cost comparisons between NASA and SAMSO models also are quite close except for the small Concept A case.

Table 4.3-16 summarizes the recurring costs and Table 4.3-17, the nonrecurring costs of all 15 Concept Models, subsystem costs and salient overall characteristics. Note also the substantial increase in weight and cost for Concepts D and D'. Cost for these models increases faster (from Concept C) than capacity, due to the impact, in the case of D, of using multiple beams at S-Band and attendant onboard channelization and switching, and in the case of

Table 4.3-8. Concept & Recurring Cost

| | CONCEPTS | | |
|---------------|----------|-------|-------|
| | B | B1 | B2 |
| COMM (LBS) | 667 | 677 | 677 |
| POWER (WATTS) | 540 | 544 | 1,059 |
| POWER (LBS) | 132 | 184 | 244 |
| TOTAL (LBS) | 1,798 | 1,913 | 2,051 |

INFLAT. FACTOR TECH INDEX COMPLEX FACTOR COMPOSITE INDEX

| | | | | | | | | |
|-------------------|------|-------|--------|-------|-------------------------------|--------|--------|--------|
| STRUCTURE/THERMAL | 1.39 | 0.878 | 1.302 | 1.589 | $Y = 19.38X^{0.66}$ | 1,303 | 1,357 | 1,421 |
| TT&C | 1.39 | 0.834 | 1.1519 | 1.335 | $Y = 14.11 + 33.04X^{0.91}$ | 1,681 | 1,777 | 1,890 |
| COMM/ANT | 1.39 | 0.873 | 2.1756 | 2.640 | $Y = 41.02X^{0.87}$ | 31,420 | 31,420 | 31,420 |
| ACS/SPS | 1.39 | 0.840 | 1.2157 | 1.419 | $Y = -103.17 + 34.93X^{0.76}$ | 2,139 | 2,250 | 2,380 |
| EPS | 1.39 | 0.90 | 1.9542 | 2.445 | $Y = 72.42W^{0.27}$ | 3,842 | 4,464 | 5,440 |
| AKM | | | | | | 900 | 900 | 500 |

SUBTOTAL \$ 41,285 K \$ 42,168 K \$ 43,451 K

PROGRAM LEVEL (0.3291)

13,587 13,877 14,300

SUBTOTAL

\$ 54,872 K \$ 56,045 K \$ 57,751 K

FEE (15%)

8,231 8,407 8,662

TOTAL RC

\$ 63,103 K \$ 64,452 K \$ 66,413 K

$W = WPS \times PFS \times 1.25$

ORIGINAL PAGE IS OF POOR QUALITY

Table 4.3-9. Concept B Nonrecurring Cost

| | CONCEPT | | |
|---------------|---------|-------|-------|
| | B | B1 | B2 |
| COMM (LBS) | 677 | 677 | 677 |
| POWER (WATTS) | 132 | 189 | 249 |
| POWER (LBS) | 540 | 844 | 1,059 |
| TOTAL (LBS) | 1,798 | 1,913 | 2,051 |

| ITEM | INFLAT. FACTOR | TECH INDEX | COMPLEX FACTOR | COMPOSITE INDEX | Y = | 6,967 | 7,200 | 7,473 |
|-------------------------|----------------|------------|----------------|-----------------|-----------------------------|---------------|---------------|---------------|
| STRUCTURE/THERMAL | 1.39 | 0.872 | 1.2237 | 1.347 | $1098.18 + 90.99X^{0.67}$ | | | |
| TT&C | 1.39 | 0.831 | 1.1661 | 2.32 | $705.23 + 34.80X$ | 5,993 | 6,273 | 6,607 |
| COMM/ANT | 1.39 | 0.884 | 3.094 | 3.802 | $468.67X^{0.57}$ | 73,162 | 73,162 | 73,162 |
| ACS/SPS | 1.39 | 0.876 | 1.236 | 2.454 | $372.82 + 27.92X$ | 11,507 | 12,185 | 12,998 |
| EPS | 1.39 | 0.876 | 1.2758 | 2.493 | $2098.95 + 0.03401W^{0.93}$ | 8,636 | 12,253 | 16,505 |
| SUBTOTAL | | | | | | \$ 106,265 K | \$ 110,073 K | \$ 116,745 K |
| PROGRAM FACTOR (0.3568) | | | | | | <u>37,915</u> | <u>39,274</u> | <u>41,655</u> |
| SUBTOTAL | | | | | | \$ 144,180 K | \$ 149,347 K | \$ 158,400 K |
| FEE (15%) | | | | | | <u>21,627</u> | <u>22,902</u> | <u>23,760</u> |
| TOTAL NRC | | | | | | \$ 165,807 K | \$ 171,799 K | \$ 182,160 K |

$W = W_{PS} \times P_{PS} \times X^{1.25}$

ORIGINAL PAGE IS OF POOR QUALITY

Table 4.3-10. Concept C Recurring Cost

| | C | C1 | C2 |
|---------------|-------|-------|-------|
| COMM (LBS) | 1,371 | 1,371 | 1,371 |
| POWER (WATTS) | 687 | 961 | 1,789 |
| POWER (LBS) | 169 | 215 | 341 |
| TOTAL (LBS) | 3,422 | 3,524 | 3,809 |

| ITEM | COMPOSITE INDEX | | | |
|------------------------|-----------------|-------------------------------|---------------|---------------|
| STRUCTURE/THERMAL | 1.589 | $Y = 19.38X^{0.66}$ | \$ 1,992 | \$ 2,031 |
| TT&C | 1.335 | $Y = 14.11 + 33.04X^{0.91}$ | 3,004 | 3,084 |
| COMM/ANT | 2.640 | $Y = 41.02X^{0.87}$ | 58,052 | 58,052 |
| ACS/SPS | 1.419 | $Y = -103.17 + 34.93X^{0.76}$ | 3,581 | 3,666 |
| EPS | 2.445 | $Y = 72.42W^{0.27}$ | 4,383 | 5,121 |
| AKM | | | <u>1,000</u> | <u>1,000</u> |
| SUBTOTAL | | | \$ 72,012 K | \$ 72,954 K |
| PROGRAM LEVEL (0.3291) | | | <u>23,699</u> | <u>24,009</u> |
| SUBTOTAL | | | \$ 95,711 K | \$ 96,963 K |
| Fee (@ 15%) | | | <u>14,357</u> | <u>14,544</u> |
| TOTAL | | | \$ 110,068 K | \$ 111,508 K |
| | | | | \$ 115,028 K |

ORIGINAL PAGE 19
OF POOR QUALITY

Table 4.3-11. Concept C Nonrecurring Cost

| | C | C1 | C2 |
|---------------|-------|-------|-------|
| COMM (LBS) | 1,371 | 1,371 | 1,371 |
| POWER (WATTS) | 687 | 961 | 1,789 |
| POWER (LBS) | 169 | 215 | 341 |
| TOTAL (LBS) | 3,422 | 3,524 | 3,809 |

COMPOSITE INDEX

| | | | | | |
|-------------------|-------|---------------------------------|----------|-----------|-----------|
| STRUCTURE/THERMAL | 1.34 | $Y = 1098.18 + 90.99X^{0.67}$ | \$ 9,926 | \$ 10,094 | \$ 10,555 |
| TT&C | 2.32 | $Y = 705.23 + 34.80X$ | 9,929 | 10,172 | 10,862 |
| COMM/ANT | 3.802 | $Y = 468.67X^{0.57}$ | 109,393 | 109,393 | 109,393 |
| ACS/SPS | 2.454 | $Y = 372.82 + 27.92X$ | 21,079 | 21,680 | 23,359 |
| EPS | 2.493 | $Y = 2098.95 + 0.03401W^{0.95}$ | 10,588 | 14,386 | 16,525* |

SUBTOTAL \$ 160,915 K \$ 165,725 K \$ 170,694 K

PROGRAM FACTOR (0.3568)

57,414 59,131 60,904

SUBTOTAL

\$ 218,329 K \$ 224,856 K \$ 231,598 K

FEE (15%)

32,749 33,728 34,740

TOTAL NRC

\$ 251,079 K \$ 258,584 K \$ 266,337 K

* MODIFIED SAMSO

$$W = W_{PS} \times P_{PS} \times 1.25$$

Table 4.3-12. Concept D' Recurring Cost

| | D' | D'1 | D'2 |
|---------------|--------|--------|--------|
| COMM (LBS) | 4,995 | 4,955 | 4,995 |
| POWER (WATTS) | 2,624 | 2,802 | 3,367 |
| POWER (LBS) | 547 | 567 | 644 |
| TOTAL (LBS) | 12,316 | 12,360 | 12,531 |

COMPOSITE INDEX

| | | | | | |
|-------------------|-------|-------------------------------|--------------|--------------|--------------|
| STRUCTURE/THERMAL | 1.589 | $Y = 19.38X^{0.66}$ | 4,639 | 4,650 | 4,693 |
| TT&C | 1.335 | $Y = 14.11 + 33.04X^{0.91}$ | 9,591 | 9,604 | 9,743 |
| COMM/ANT | 2,640 | $Y = 41.02X^{0.87}$ | 178,782 | 178,782 | 178,782 |
| ACS/SPS | 1.419 | $Y = -103.17 + 34.93X^{0.76}$ | 9,720 | 9,747 | 9,851 |
| EPS | 2.445 | $Y = 72.42W^{0.27}$ | 8,643 | 8,884 | 9,662 |
| AKM | | | <u>2,000</u> | <u>2,000</u> | <u>2,000</u> |
| SUBTOTAL | | | \$ 213,375 K | \$ 213,667 K | \$ 214,731 K |

PROGRAM LEVEL (0.3291)

| | | | |
|-----------|---------------|---------------|---------------|
| SUBTOTAL | <u>70,222</u> | <u>70,318</u> | <u>70,668</u> |
| FEE (15%) | 42,540 | 42,598 | 42,810 |
| TOTAL | \$ 326,136 K | \$ 326,583 K | \$ 328,209 K |

$W = W_{PS} \times P_{PS} \times 1.25$

Table 4.3-13. Concept D' Nonrecurring Cost

| | D' | D'1 | D'2 |
|---------------|--------|--------|--------|
| COMM (LBS) | 4,955 | 4,995 | 4,995 |
| POWER (WATTS) | 2,624 | 2,802 | 3,367 |
| POWER (LBS) | 547 | 567 | 644 |
| TOTAL (LBS) | 12,316 | 12,360 | 12,531 |

COMPOSITE INDEX

| | | | | | | |
|------------------------|-------|--|------------------------|----------------|----------------|----------------|
| STRUCTURE/THERMAL | 1.347 | Y = 1098.18 | 90.99X ^{0.67} | 21,402 | 21,450 | 21,634 |
| TT&C | 2.32 | Y = 705.23 + 34.80X | | 31,466 | 31,573 | 31,987 |
| COMM/ANT | 3.802 | Y = 468.67X ^{0.57} | | 228,583 | 228,583 | 228,583 |
| ACS/SFS | 2.454 | Y = 372.82 + 27.92X | | 73,485 | 73,744 | 74,752 |
| EPS | 2.493 | Y = 2098.95 + 0.03401W ^{0.93} | | 22,760* | 24,090* | 28,308* |
| SUBTOTAL | | | | \$ 377,695 K | \$ 379,440 K | \$ 385,264 K |
| PROGRAM LEVEL (0.3568) | | | | <u>134,761</u> | <u>135,384</u> | <u>137,462</u> |
| SUBTOTAL | | | | \$ 512,458 K | \$ 514,824 K | \$ 522,726 K |
| FEE (15%) | | | | <u>76,869</u> | <u>77,224</u> | <u>78,410</u> |
| TOTAL | | | | \$ 589,327 K | \$ 592,048 K | \$ 601,135 K |

W = W_{PS} X P_{PS} X 1.25

* MODIFIED SAMSO

Table 4.3-14. Concept D Recurring Cost

| | D | D1 | D2 |
|---------------|--------|--------|--------|
| COMM (LBS) | 5,506 | 5,506 | 5,506 |
| POWER (WATTS) | 9,033 | 9,221 | 9,775 |
| POWER (LBS) | 1,985 | 2,026 | 2,148 |
| TOTAL (LBS) | 16,647 | 16,738 | 17,011 |

COMPOSITE INDEX

| | | |
|-------------------|-------|-------------------------------|
| STRUCTURE/THERMAL | 1.589 | $Y = 19.38X^{0.66}$ |
| TT&C | 1.335 | $Y = 14.11 + 33.04X^{0.91}$ |
| COMM/ANT | 2.640 | $Y = 41.02X^{0.87}$ |
| ACS/SPS | 1.419 | $Y = -103.17 + 34.93X^{0.76}$ |
| EPS | 2.445 | $Y = 72.42X^{0.27}$ |
| AKM | | |

| | | | |
|------------------------|---------------|---------------|---------------|
| STRUCTURE/THERMAL | 5,660 | 5,681 | 5,742 |
| TT&C | 12,611 | 12,674 | 12,862 |
| COMM/ANT | 194,593 | 194,593 | 194,593 |
| ACS/SPS | 12,259 | 12,311 | 12,465 |
| EPS | 17,091 | 17,282 | 17,835 |
| AKM | <u>2,500</u> | <u>2,500</u> | <u>2,500</u> |
| SUBTOTAL | \$ 244,714 K | \$ 245,041 K | \$ 245,997 K |
| PROGRAM LEVEL (0.3291) | <u>80,535</u> | <u>80,643</u> | <u>80,958</u> |
| SUBTOTAL | \$ 325,249 K | \$ 325,684 K | \$ 326,955 K |
| FEE (15%) | <u>48,787</u> | <u>48,853</u> | <u>49,043</u> |
| TOTAL | \$ 374,037 K | \$ 374,537 K | \$ 375,998 K |

ORIGINAL PAGE IS
OF POOR QUALITY

$$W = W_{PS} \times P_{PS} \times X^{1.25}$$

Table 4.3-15. Concept D Nonrecurring Cost

| | D | D1 | D2 |
|---------------|--------|--------|--------|
| COMM (LBS) | 5,506 | 5,506 | 5,506 |
| POWER (WATTS) | 9,933 | 9,221 | 9,775 |
| POWER (LBS) | 1,985 | 2,026 | 2,148 |
| TOTAL (LBS) | 16,647 | 16,738 | 17,011 |

COMPOSITE INDEX

| | | | | | |
|-------------------|-------|--------------------------------|---------|---------|---------|
| STRUCTURE/THERMAL | 1.347 | $Y = 1098.18 + 90.99X^{0.67}$ | 25,859 | 25,948 | 26,215 |
| TT&C | 2.32 | $Y = 705.23 + 34.80X$ | 41,956 | 42,177 | 42,838 |
| COMM/ANT | 3.802 | $Y = 468.67X^{0.57}$ | 241,633 | 241,633 | 241,633 |
| ACS/SPS | 2.454 | $Y = 372.32 + 27.92X$ | 99,005 | 99,541 | 101,150 |
| EPS | 2.493 | $Y = 2098.95 + 0.0340W^{0.93}$ | 70,616* | 72,020* | 76,157* |

| | | | |
|------------------------|----------------|----------------|----------------|
| SUBTOTAL | \$ 479,069 K | \$ 481,319 K | \$ 487,993 K |
| PROGRAM LEVEL (0.3568) | <u>170,932</u> | <u>171,735</u> | <u>174,110</u> |
| SUBTOTAL | \$ 650,001 K | \$ 653,054 K | \$ 662,109 K |
| FEE (15%) | <u>97,500</u> | <u>97,958</u> | <u>99,316</u> |
| TOTAL | \$ 747,501 K | \$ 751,012 K | \$ 761,425 K |

ORIGINAL PAGE IS OF POOR QUALITY

$W = W_{PS} \times P_{PS} \times 1.25$

* MODIFIED SAMSO

D', using Ku-Band with a high allowance for fading. Because of these considerations the trunk costs for Concepts D and D' are higher than for Concept C, which has lower capacity.

4.3.2.4 Total Space Investment

Total space system investment (excludes gateways and mobiles which are considered separately) includes satellite costs, launch vehicle and launch insurance costs, control center cost, and launching costs. It is assumed that three satellites are purchased, on average, and that two are launched. Launch vehicle costs are based on \$60M per shuttle launch using a 4/3 factor for shared launches. Unfortunately, there is a dearth of capability for the larger satellites. While IUS is available, and capable of injecting a 5000 pound satellite into synchronous orbit its sophistication is probably not warranted for a commercial venture, and of course it is very expensive. Alternatives such as the Centaur, capable of injecting 10,000 pounds into synchronous orbit are possible but not funded. In addition, the cost of any vehicle depends to a large extent on production and launch activity which is difficult to predict so far into the future for the higher payload capabilities. Alternately it has been assumed that, like the PAM-D and PAM-A, the trend in new spacecraft in the future will require a low cost capability for heavier payloads and that such transtages will be available. Estimated costs of these used for the Study are \$12M for a 5000 pound spacecraft, \$27M for a 10,000 pound capability and \$35M for a 15,000 pound capability. The resultant space investment is described in Table 4.3-18 for the 15 possible configurations. Also tabulated is the total bandwidth provided by a two satellite system, the bandwidth utilization factor (allowance for diplexing), and the total investment per 15 kHz or 4 kHz trunk. From Concept A to C capacity increases by a factor of 15 and costs decrease by a factor of about 4.5. Note that the costs for concepts D and D', measured in investment per circuit increase because of the effect of the fixed link. Concept D' Ku-Band link requires extra power to overcome downlink fading due to rain. Concept D requires additional power and weight for the onboard channelization and switching. Over the total range of Concepts A to D' (excluding D), capacity increased by a factor of 25 and investment per circuit decreases by a factor of 3:1.

ORIGINAL PAGE IS
OF POOR QUALITY

Table 4.3-16. Recurring cost Summary (SAMS0)

| | A | A1 | A2 | B | B1 | B | C | C1 | C2 | D' | D'T | D'2 | D | D1 | L. |
|--------------------------------------|-------|-------|-------|-------|-------|-------|--------|--------|--------|--------|--------|--------|--------|--------|--------|
| COMMUNICATION/ANTENNA WEIGHT, LBS | 114 | 118 | 130 | 677 | 677 | 679 | 1371 | 1371 | 1371 | 4995 | 4995 | 4995 | 5506 | 5506 | 5506 |
| POWER, EOL, WATTS | 767 | 1948 | 5682 | 540 | 844 | 1059 | 687 | 961 | 1789 | 2624 | 2802 | 3367 | 9033 | 9221 | 9775 |
| SPACECRAFT WEIGHT, LBS | 593 | 1012 | 2053 | 1798 | 1913 | 2051 | 3422 | 3524 | 3809 | 12316 | 12360 | 12531 | 16647 | 16738 | 17011 |
| STRUCTURE/THERMAL (1) \$000'S | 627 | 892 | 1422 | 1303 | 1357 | 1421 | 1992 | 2031 | 2138 | 4639 | 4650 | 4693 | 5660 | 5681 | 5742 |
| TT&C (1) \$000'S | 624 | 1004 | 1894 | 1681 | 1777 | 1890 | 3004 | 3084 | 3309 | 9591 | 9604 | 9743 | 12611 | 12574 | 12862 |
| COMM/ANT (1) \$000'S | 6690 | 6883 | 7482 | 31420 | 31420 | 31420 | 58052 | 58052 | 58052 | 178782 | 178782 | 178782 | 194593 | 194593 | 214593 |
| ACS/SPS (1) \$000'S | 837 | 1330 | 2382 | 2139 | 2250 | 2380 | 3581 | 3666 | 3898 | 9720 | 9747 | 9851 | 12259 | 12311 | 12465 |
| EPS (1) \$000'S | 4396 | 6588 | 11775 | 3842 | 4464 | 5540 | 4383 | 5121 | 6860 | 8643 | 8884 | 9652 | 17091 | 17282 | 17835 |
| TOTAL COST, \$M | 21.36 | 26.74 | 39.58 | 63.10 | 64.45 | 66.41 | 110.07 | 111.51 | 115.03 | 326.1 | 326.6 | 328.2 | 374.0 | 374.5 | 376.0 |

(1) NOT INCLUDING "PROGRAM LEVEL" COST AND FEE

ORIGINAL PAGE IS
OF POOR QUALITY

Table 4.3-17. Nonrecurring Cost Summary (SAMSO)

| | A | A1 | A2 | B | B1 | B2 | C | C1 | C2 | D' | D'1 | D'2 | D | D1 | D2 |
|-----------------------------------|-------|-------|-------|-------|-------|-------|--------|--------|--------|--------|--------|--------|--------|--------|--------|
| COMMUNICATION/ANTENNA WEIGHT, LBS | 114 | 118 | 130 | 677 | 677 | 677 | 1371 | 1371 | 1371 | 4995 | 4995 | 4995 | 5506 | 5506 | 5506 |
| POWER, EOL, WATTS | 767 | 1948 | 5682 | 540 | 884 | 1059 | 687 | 961 | 1789 | 2624 | 2802 | 3367 | 9033 | 9221 | 9775 |
| SPACECRAFT WEIGHT, LBS | 593 | 1012 | 2053 | 1798 | 1913 | 2051 | 3422 | 3524 | 3809 | 12316 | 12360 | 12531 | 16447 | 16738 | 17011 |
| STRUCTURE/THERMAL (1) \$000'S | 4090 | 3214 | 7478 | 6967 | 7200 | 7473 | 9926 | 10094 | 10555 | 21402 | 21450 | 21634 | 25859 | 25948 | 26215 |
| TT&C (1) \$000'S | 3072 | 4087 | 6609 | 5993 | 6273 | 6607 | 9929 | 10172 | 10862 | 31466 | 31573 | 31987 | 41956 | 42177 | 42838 |
| COMM/ANTA (4) \$000'S | 26557 | 27056 | 28577 | 73162 | 73162 | 73162 | 109393 | 109393 | 109393 | 228583 | 228583 | 228583 | 241633 | 241633 | 241633 |
| ACS/SPS (1) \$000'S | 4409 | 6878 | 13012 | 11507 | 12185 | 12998 | 21079 | 21680 | 23359 | 73485 | 73744 | 74752 | 99005 | 99541 | 101150 |
| EPS (1) \$000'S | 10641 | 15991 | 45594 | 8636 | 12253 | 16505 | 10588 | 14386 | 16525 | 22760 | 24090 | 28308 | 70616 | 72020 | 76157 |
| TOTAL COST \$M | 75.1 | 92.4 | 158.0 | 165.8 | 171.7 | 182.2 | 251.1 | 258.6 | 266.3 | 589.3 | 592.0 | 601.1 | 747.5 | 751.0 | 761.4 |

(1) NOT INCLUDING "PROGRAM LEVEL" COST AND FCE

ORIGINAL PAGE 19
OF POOR QUALITY

The investment per subscriber can be computed approximately from Table 4.3-18 by assuming that the number of available trunks is numerically equal to the traffic capacity and that the number of subscribers is equal to the reciprocal of the traffic intensity per user, in erlangs.

For radio telephone the traffic intensity per subscriber is .03 erlangs or approximately 33 subscribers per circuit; for dispatch service, the traffic intensity per subscriber is .01 erlangs or approximately 100 subscribers per circuit. The results, in Table 4.3-18 tabulate the total investment per 15 kHz or 4 kHz trunk, and the investment per subscriber for the two trunk types. The investment per dispatch subscriber is less by an order of magnitude due to the larger number of 4 kHz trunks, and larger number of 4 kHz dispatch subscribers per trunk. The beam fill factor is assumed to be 1.0 (e.g., all the beams have the same capacity).

The previously described interactive data and position location services, based on a 4 kHz trunk, two messages per day per mobile and a total of approximately 50,000 mobiles per trunk results in a miniscule investment per mobile, in the range of \$.20 to \$1.00 per mobile.

**ORIGINAL PAGE IS
OF POOR QUALITY**

Table 4.3-18. Space Investment (millions of 1982 dollars)

| | A | A1 | A2 | B | B1 | B2 | C | C1 | C2 | D' | D'1 | D'2 | D | D1 | D2 |
|--|--------|--------|--------|--------|--------|--------|--------|--------|--------|--------|--------|--------|--------|--------|--------|
| SATELLITES (3) | 64.1 | 80.2 | 118.8 | 189.3 | 193.4 | 199.2 | 330.2 | 334.5 | 345.1 | 978.3 | 984.6 | 984.6 | 1122 | 1124 | 1128 |
| DESIGN COST | 76.1 | 92.4 | 158.0 | 165.8 | 171.7 | 182.2 | 251.1 | 258.6 | 266.3 | 589.3 | 592 | 601.1 | 747.5 | 751.0 | 761.4 |
| LAUNCH VEHICLE COST (2) | 50 | 50 | 70 | 60 | 64 | 68 | 110 | 112 | 116 | 180 | 180 | 180 | 196 | 196 | 196 |
| INSURANCE (2 LAUNCHES) @ 12 % | 11.1 | 12.4 | 17.9 | 22.3 | 23.1 | 24.1 | 39.6 | 40.2 | 41.5 | 100 | 100 | 100 | 113 | 113.4 | 113.8 |
| NOC/SOC (1) | 15 | 15 | 15 | 15 | 15 | 15 | 15 | 15 | 15 | 15 | 15 | 15 | 15 | 15 | 15 |
| LAUNCHING COST (2) | 8 | 8 | 8 | 8 | 8 | 8 | 8 | 8 | 8 | 8 | 8 | 8 | 8 | 8 | 8 |
| MISC. | 5 | 5 | 5 | 5 | 5 | 5 | 5 | 5 | 5 | 5 | 5 | 5 | 5 | 5 | 5 |
| TOTAL | 229.3 | 263.0 | 392.7 | 465.4 | 480.2 | 501.5 | 758.9 | 773.3 | 796.9 | 1876 | 1885 | 1894 | 2207 | 2212 | 2227 |
| TOTAL BANDWIDTH, MHz | 20 | 20 | 20 | 60 | 60 | 60 | 155 | 155 | 155 | 500 | 500 | 500 | 500 | 500 | 500 |
| BANDWIDTH UTILIZATION | 1.0 | 1.0 | 1.0 | 0.9 | 0.9 | 0.9 | 0.9 | 0.9 | 0.9 | 0.9 | 0.9 | 0.9 | 0.9 | 0.9 | 0.9 |
| INVEST. PER 15 KHz (\$M) | 0.172 | 0.197 | 0.294 | 0.129 | 0.133 | 0.139 | 0.0816 | 0.0832 | 0.0857 | 0.0662 | 0.0628 | 0.0631 | 0.0736 | 0.0737 | 0.0782 |
| INVEST. PER 4 KHz (\$M) | 0.0459 | 0.0525 | 0.0784 | 0.0344 | 0.0355 | 0.0371 | 0.0218 | 0.0222 | 0.0229 | 0.0177 | 0.0167 | 0.0168 | 0.0196 | 0.0276 | 0.0198 |
| INVEST PER RADIO TELEPHONE SUBSCRIBER, \$ | 5212 | 5970 | 8909 | 3909 | 4030 | 4212 | 2473 | 2521 | 2597 | 2006 | 1903 | 1912 | 2230 | 2233 | 2248 |
| INVEST. TRUNKING SUBSCRIBER, \$ | 459 | 525 | 785 | 344 | 355 | 371 | 218 | 222 | 225 | 177 | 167 | 168 | 196 | 276 | 198 |

REFERENCES

1. A Technique for Modeling Communications Satellites, Comsa: Technical Review Volume 2, Number 1, 1972, Page 73 to 103.

4.4 SUBSCRIBER CHARGES

4.4 SUBSCRIBER CHARGES

ORIGINAL PAGE IS
OF POOR QUALITY

4.4.1 METHODOLOGY

Space segment investment can be converted into periodic subscriber charges by relating the investment to payback, expenses, taxes, depreciation, and return on investment, and return on sales. To be commercially attractive the return on investment should be considerably higher than the expected prime interest rate.

The method follows that of reference (1) except for a modified payback scheme.

$$\text{Total Income} = \quad (1)$$

$$\int_0^{T_0} C_u N(t) dt$$

C_u = channel charge

N = number of channels in use

T_0 = system lifetime

$$\text{Expense} = KR \text{ per annum} \quad (2)$$

R = lump sum system investment

$$\text{Depreciation} = R/T_0 \text{ per annum} \quad (3)$$

$$\text{Total Taxes} = .46 \int_0^{T_0} [C_u N(t) dt - \frac{R}{T_0} - KR] dt \quad (4)$$

$$\text{Total Payback} = \int_0^{T_0} C_u N(t) dt - \int_0^{T_0} KR dt - \quad (5)$$

$$-.46 \int_0^{T_0} [C_u N(t) - \frac{R}{T_0} - KR] dt$$

The payback retires the original investment. The approach taken for the study is to first assume an exponential payback relationship, e.g. payback grows with income (assuming an exponential capacity growth at rate "r" by N (t)), but each year, the payback retires a portion of the outstanding investment. At the same time, a return on investment "i" is obtained on the outstanding yearly investment. In addition, a constant capacity is assumed in order to compute the "asymptotic" case. In this case, payback is constant. The exponential payback scheme is described in Table 4.4-1 illustrating the exponentially increasing payback and the return on investment "i" obtained each year. The residual in the final year must be zero (investment retired), so that

ORIGINAL PAGE 13
OF POOR QUALITY (6)

$$1 = \frac{A}{R} \sum_{k=1}^{T_0} \left(\frac{(1+r)^k}{(1+i)^k} \right) \quad \text{or}$$

$$\frac{R}{A} = \sum_{k=1}^{T_0} \left(\frac{(1+r)^k}{(1+i)^k} \right) \quad (7)$$

Table 4.4-1. Payback Schedule Exponential Capacity Growth

| t | OUTSTANDING INVESTMENT | PAYBACK | RESIDUAL |
|---|---|------------------------|---|
| 0 | R | 0 | -- |
| 1 | R (1 + i) | A (1 + r) | R (1 + i) $\left(1 - \frac{A}{R} \frac{1+r}{1+i} \right)$ |
| 2 | R (1 + i) ² $\left(1 - \frac{A}{R} \frac{1+r}{1+i} \right)$ | A (1 + r) ² | R (1 + i) ² $\left[1 - \frac{A}{R} \left(\frac{1+r}{1+i} \right) - \frac{A}{R} \left(\frac{1+r}{1+i} \right)^2 \right]$ |
| 3 | ETC | A (1 + r) ³ | ETC |
| 4 | ETC | A (1 + r) ⁴ | ETC |
| 5 | ETC | A (1 + r) ⁵ | ETC |
| 6 | ETC | A (1 + r) ⁶ | ETC |
| 7 | ETC | A (1 + r) ⁷ | R (1 + i) ^{T₀} $\left[1 - \frac{A}{R} \sum_{K=1}^{T_0} \left(\frac{1+r}{1+i} \right)^K \right]$ |

Since i , r , K and T_0 are known, A also is known. Consequently,

$$\begin{aligned} \text{Total Payback} &= \int_0^{T_0} A (1+r)^t dt \\ &= \frac{A}{\ln(1+r)} [(1+r)^{T_0} - 1] \end{aligned} \tag{8}$$

ORIGINAL PAGE IS
OF POOR QUALITY

Note that if $r = 0$ (constant capacity)

$$\text{Total Payback} = AT_0 \tag{9}$$

Integrating and collecting terms results in

$$C_u = \frac{R \left\{ \frac{A}{R} \left[\frac{(1+r)^{T_0} - 1}{\ln(1+r)} \right] + 0.54K T_0 - .46 \right\}}{\left(\frac{0.54 N_0}{(1+r)^{T_0}} \right) \left[\frac{(1+r)^{T_0} - 1}{\ln(1+r)} \right]} \tag{10}$$

where:

$$N(t) = N_0 \frac{(1+r)^t}{(1+r)^{T_0}} \tag{11}$$

$N_0 = \text{final capacity}$

$$\text{and } \int_0^{T_0} N(t) dt = N_0 \left[\frac{(1+r)^{T_0} - 1}{(1+r)^{T_0} \ln(1+r)} \right] \tag{12}$$

Equation (10) defines the annual subscriber charge necessary to retire the investment and generate the required return on investment at the postulated capacity growth. The subscriber charge is proportional to the investment and inversely proportional to the capacity. More precisely, the denominator term:

$$N_0 \left[\frac{(1+r)^{T_0} - 1}{(1+r)^{T_0} \ln(1+r)} \right] \text{ is } = \int_0^{T_0} N(t) dt \quad \text{and}$$

represents the circuit-years generated by the subscribers. The subscriber charge is the same if the circuit-years are the same (there are some small differences, for example, between the exponential and constant capacity cases, because the payback schedules differ slightly).

Consider the case where growth is constant, e.g. $r = 0$

$$N(t) = N_0 \quad (13)$$

and $\int_0^{T_0} N(t) dt = N_0 T_0$ ORIGINAL PAGE IS
OF POOR QUALITY (14)

Payback A is a constant. Table 4.4-2 describes the payback required for the case of constant capacity (constant income). Then

$$R (1+i)^{T_0} \left[1 - \frac{A}{R} \sum_{k=1}^{T_0} \left[\frac{1}{1+i} \right]^k \right] = 0 \quad (15)$$

$$\text{or } \frac{R}{A} = \sum_{k=1}^{T_0} \left[\frac{1}{1+i} \right]^k \quad (16)$$

Constant capacity cases can be used to compute the asymptotic subscriber charge, e.g. the lowest satellite charge, achieved when the satellite system is uniformly and fully loaded for the entire 7 years. An additional case, that of constant capacity which is one sixth of the maximum also is used, thus providing a range of circuit-years over which subscriber charges are computed. It should be noted that the "likely", "optimistic" and "conservative" cases are based on exponential growth. The subscriber charge for this value of subscriber-years is slightly different than that of constant capacity, for the same subscriber-years due to slight differences in the payback schedule for the two cases. For constant payback the channel charge is:

$$C_u = \frac{A + 0.54 KR - .46 R/T_0}{.54 N_0} \quad (17)$$

Table 4.4-2. Payback Schedule for Constant Capacity

| t (SPARE) | OUTSTANDING INVESTMENT | PAYBACK | RESIDUAL |
|--------------|--|---------|--|
| 0 | R | 0 | |
| 1 | R (1 + i) | A | R (1 + i) - A |
| 2 | $R (1 + i)^2 \left[1 - \frac{A}{R} \left(\frac{1}{1+i} \right) \right]$ | A | $R (1 + i)^2 \left[1 - \frac{A}{R} \left(\frac{1}{1+i} \right) \right] - A$ |
| 3 | $R (1 + i)^3 \left[1 - \frac{A}{R} \left(\frac{1}{1+i} \right) - \frac{A}{R} \left(\frac{1}{1+i} \right)^2 \right]$ | A | ETC |
| 4 | ETC | A | |
| 5 | | A | |
| 6 | | A | |
| 7 | | A | $R (1 + i)^{T_0} \left[1 - \frac{A}{R} \sum_{K=1}^{T_0} \left(\frac{1}{1+i} \right)^K \right]$ |

where $A = R$

$$K = \frac{1}{1 + \frac{T_0}{(1+T)^K}}$$

ORIGINAL FACTORS
OF POOR QUALITY

4.4.2 GENERAL RESULTS

The annual cost for a standardized (equivalent 4 KHz) trunk may be computed using the methodology and results developed in Section 4.4.1 and the space segment investment depicted graphically in Figure 4.4.-1. The equivalent trunk charge will be converted to subscriber charges for specific services, in the following section.

Three cases are investigated based on the conservative, likely and optimistic market projections, depicted in Figure 4.3-2. In each of these cases, the 14 year time period is divided into two 7 year time periods, defined as a "first" generation system (for 7 years) followed by a "second" generation system (for 7 years). Space system investment is determined by that satellite capacity

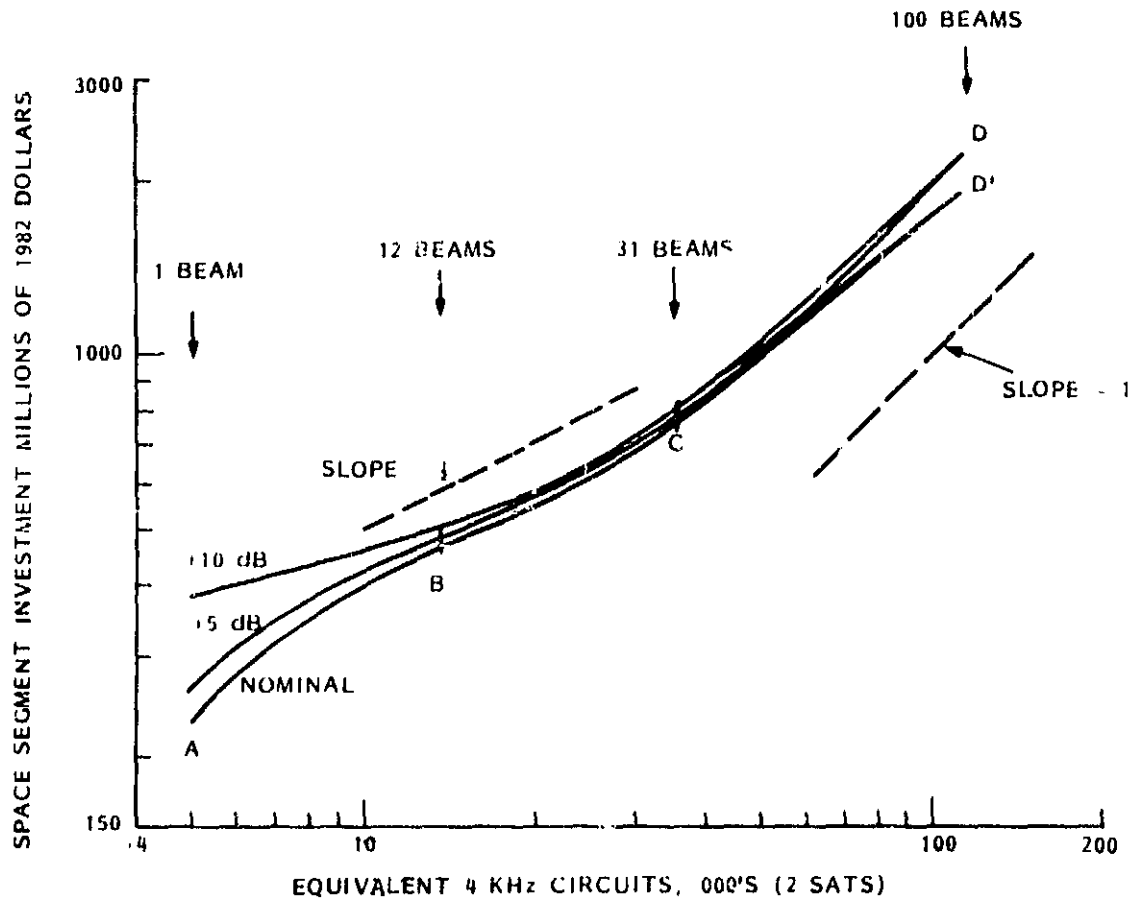

Figure 4.4-1. Space Segment Investment versus Equivalent 4 KHz Circuits for Various UHF Satellite Powers.

that exceeds the market projection (for the given period) by 20%, e.g. the satellite system is oversized" by 20%. When applicable the investment has three values, for the nominal, +5 db and +10 db cases. Consequently, the annual equivalent trunk charge is evaluated as a function of the circuit-years generated, return on investment "i", the satellite power generated and whether the system is first or second generation.

4.4.2.1 Likely Market Projection

In this case the satellite capacity is 48,000 and 80,400 equivalent circuits for first and second generations, respectively. The corresponding space system investments are \$950M, \$960M and \$979M for the first generation and \$1439M, \$1450M and \$1470M for the second generation systems.

Expense is based on $K = 1/t$, which assumes that the space segment is provided by a carrier which does not own, operate or maintain the gateways or the mobiles. The results for both generation systems are depicted in Figure 4.4-2, which shows the annual cost (in 1982 dollars) of an equivalent 4 KHz trunk cost versus the number of "circuit-years" accumulated over the system lifetime. The abscissa is merely the integral of the traffic (as a function of time), e.g. 10,000 circuits for each of seven years is 70,000 circuit years. Both first generation (1987 - 1993 inclusive), and second generation (1,994 - 2,000, inclusive) systems are displayed, at nominal UHF power and plus 10 dB, and at return on investment of 20% and 40%. The plots indicate that the annual circuit costs are inversely proportional to the circuit-years. Space segment costs are based on 20% excess system capacity at end of system life. Consequently, for each generation the nominal traffic projection, in circuit-years is indicated as well as the maximum.

The latter assumes a fully loaded satellite for seven years, hence this point represents the lowest or asymptotic cost for that particular system. The curves are slightly "bent," particularly for the higher return on investment because of the slight influence of the payback schemes, which differ according to the traffic growth pattern (constant or exponential).

It is apparent that circuit costs are insensitive to satellite UHF power over the 10 db power range, and doubling investment return increases circuit costs by approximately 80%. Annual trunk cost for the first generation nominal market projection is \$13,500 per year per trunk, and for the second generation

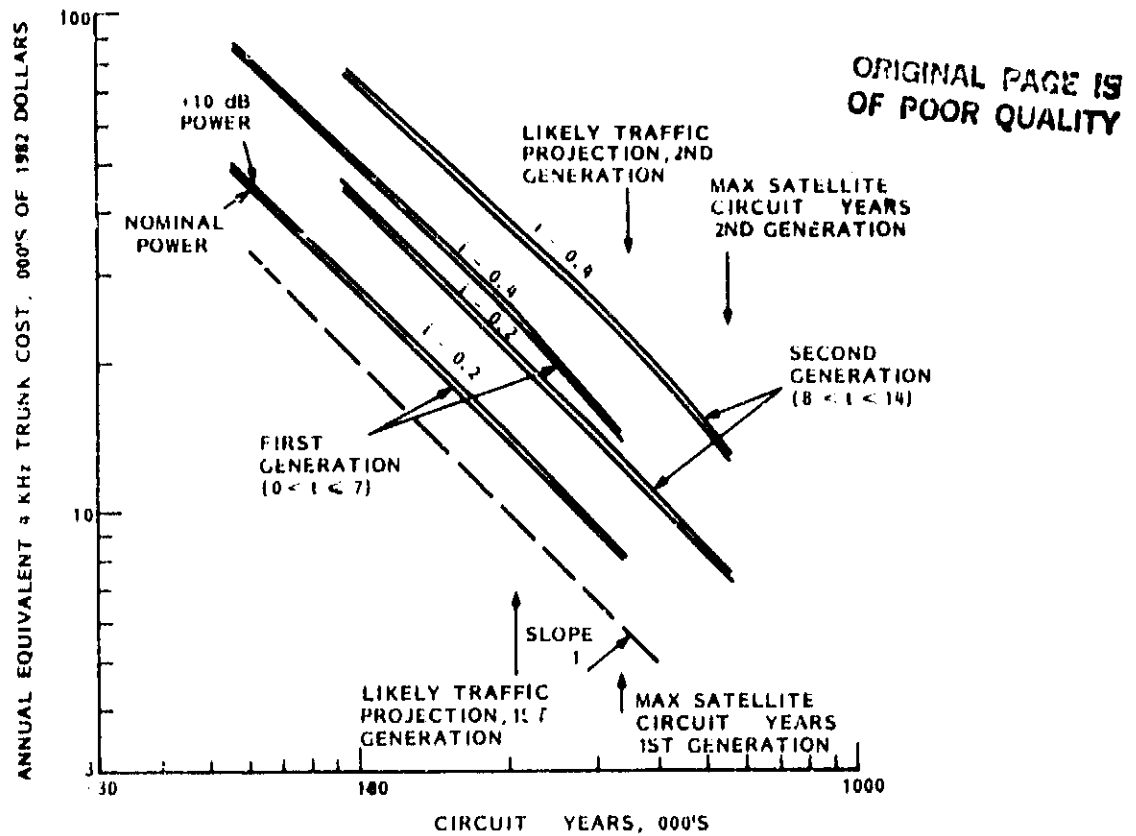

Figure 4.4-2. Equivalent Trunk Cost versus Circuit-Years for Likely Market Projection

is \$11,800 per year, a decrease of 13%, despite an increased utilization from 205,360 to 351,274 circuit-years, or 70% increase. It is apparent that space segment costs also are increasing substantially in this interval.

4.4.2.2 Optimistic Market Projection

The optimistic traffic projection results in the equivalent circuit charges depicted in Figure 4.4-3 for the first generation, and Figure 4.4-4 for the second generation systems. Differences in cost due to satellite UHF power differences of 10 dB from the nominal case are still discernible in Figure 4.4-3 (but not significant) but are no longer discernible in Figure 4.4-4. Annual trunk charge for the first generation system at the optimistic case utilization (302,120 circuit years) is \$11,500 per year and falls only to \$10,300 per year (584,491 circuit-years) for the second generation system, again because of rapidly increasing space system charges with utilization. The space system assumed in this case has a single KuBand beam, e.g. no on-board switching which has a lower cost than the alternative multiple beam S-Band system with on-board switching.

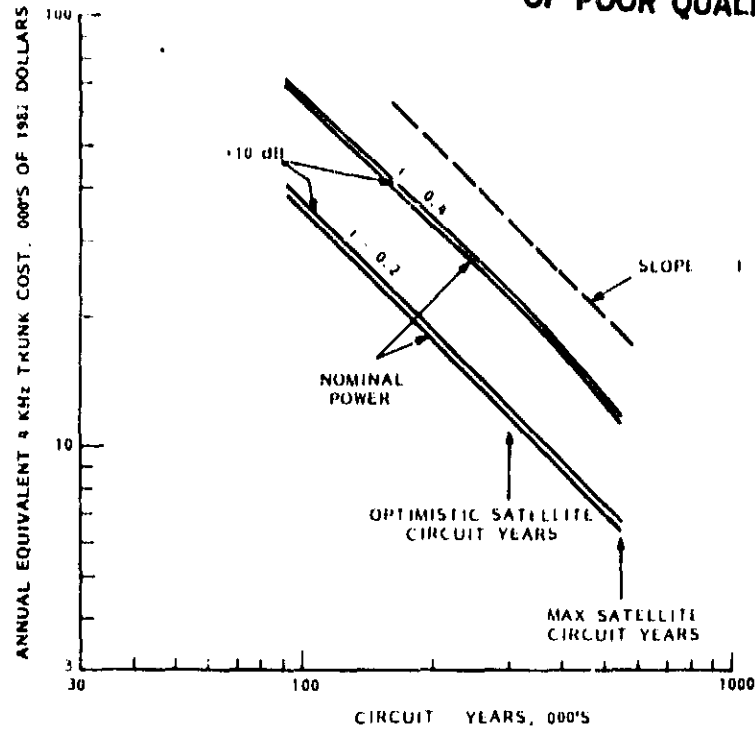

Figure 4.4-3. Equivalent Trunk Cost versus Circuit-Years for Optimistic Market Projection, First Generation

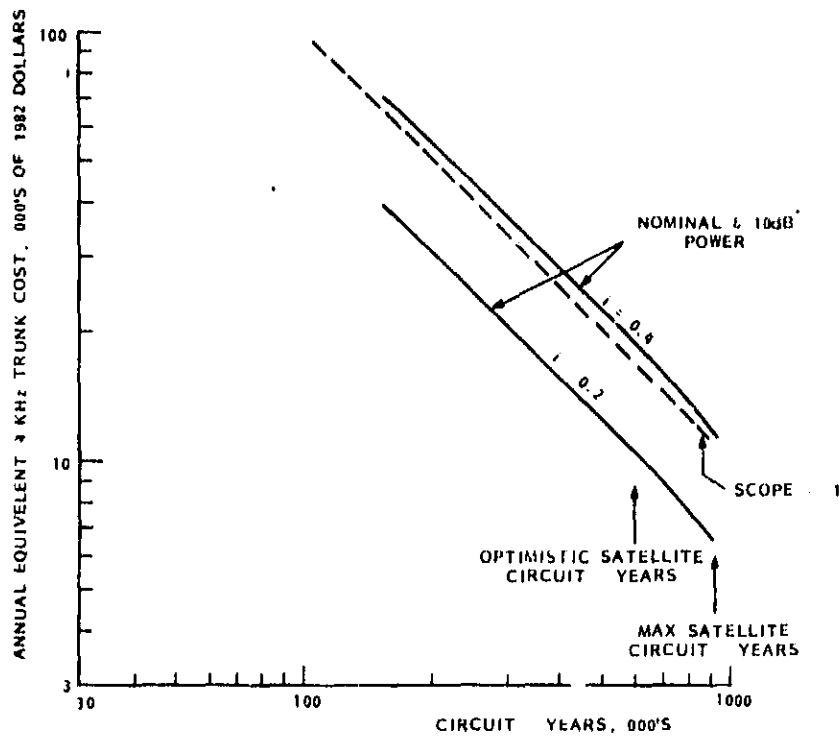

Figure 4.4-4. Equivalent Trunk Cost versus Circuit-Years for Optimistic Market Projection, Second Generation

4.4.2.3 Conservative Market Projection

The conservative traffic projection results in the equivalent circuit charges depicted in Figure 4.4-5 for the first generation and Figure 4.4-6 for the second generation space systems. Differences in cost due to satellite UHF power differences of +5 dB and +10 dB from the nominal case are clearly discernible and, of course, result from the lower antenna gain of these satellites. At the conservative traffic projection, utilizing a 10 db range results in 13% increase in cost in the first generation and 7% increase in cost in the second generation systems. Trunk costs ($i = 0.2$) for the first generation at the conservative traffic utilization (60,204 circuit-years) is \$20,800, and falls to \$18,200 during the second generation (78,265 circuit-years).

4.4.3 PARTICULAR RESULTS

4.4.3.1 Subscriber Charge Methodology

Particular results can now be examined in order to parametrically predict subscriber charges for the various services so that important system choices and characteristics are identified, and guidance provided for the development of future LMSS. Two forms of subscriber charges are believed necessary to categorize a service. One of these is the expected monthly service charge for a typical user operating at the "average" call rate. The second is the actual charge per call-minute. Both are used to identify the economic attractiveness of the various services and to provide comparisons with alternative systems, (the reader should recall that investment charges per equivalent trunk and per subscriber were previously presented.)

It should be noted that only the space segment charges are discussed in this section (which include the space segment fixed link costs). Gateway charges and mobile radio costs are discussed elsewhere.

Call minute charges are based on 525 minutes per month usage for telephone, 175 minutes per month for dispatch.

The subscriber charge in cents per call-minute, C_s is given by:

$$C_s = \frac{C_{uBPT}}{5256EF} \quad (19)$$

where

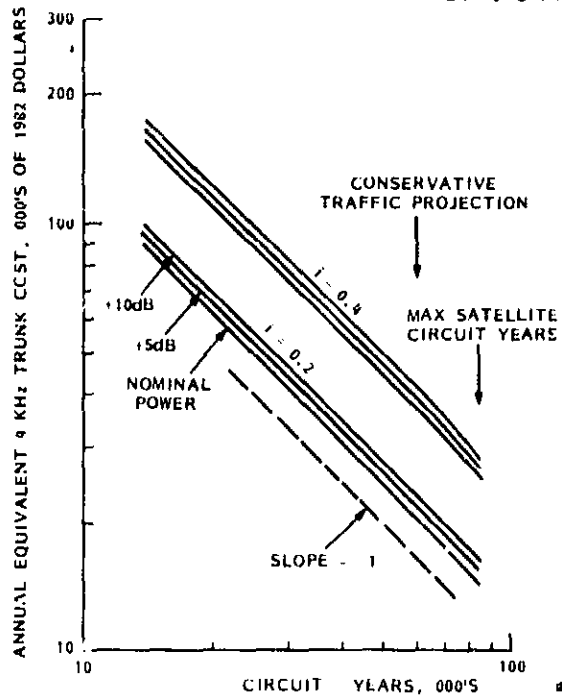

Figure 4.4-5. Equivalent Trunk Cost Versus Circuit-Years for Conservative Market Projection, First Generation

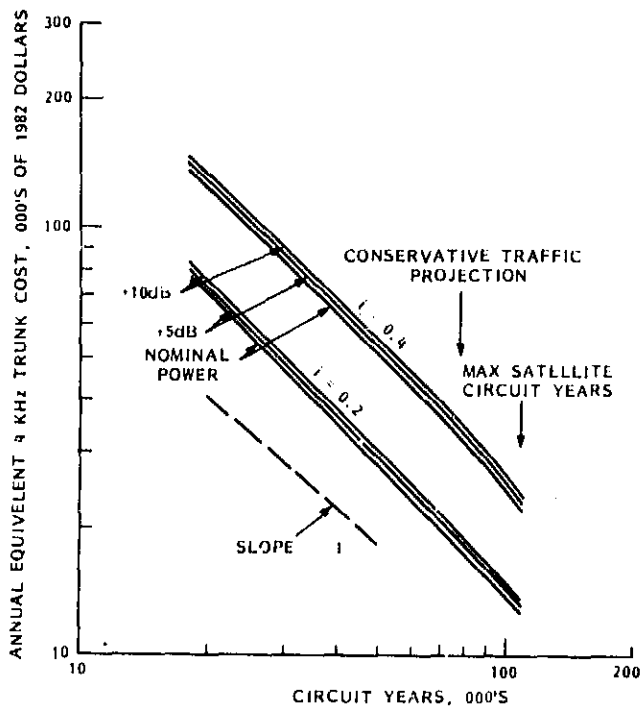

Figure 4.4-6. Equivalent Trunk Cost versus Circuit-Years for Conservative Market Projection, Second Generation

- C_s = subscriber charge per call-minute, cents, for dial-up voice (or equivalent data), space segment only.
 C_u = equivalent 4 KHz annual trunk charge, dollars, a function of satellite generation, traffic demand (e.g. utilization), satellite UHF power, return on investment, etc. provided in Section 4.3.2.
 B = service bandwidth factor related to 4 KHz (for 30 KHz, $B = 30/4 = 7.5$)*
 P = peak to average factor, typically 2
 E = Trunk efficiency of available network, see Table 4.4-3, E is less than one.
 T = number of equivalent trunks needed, ($T=1$ if service permits use of both polarizations).
 F = fill factor

The subscriber monthly charge C_m , in dollars per month is given by:

$$C_m = \frac{437.8eC_s}{P} \quad (20)$$

where:

- C_m = Total monthly service charge, (space segment only), dollars.
 e = Peak (typical) subscriber demand during the busy hour, erlangs.

While specific values for the terms in the above equations will be assumed, the reader is encouraged to make his own individual assessment. Note also that C_u , C_s , and C_m are for all practical purposes, directly proportional to space segment investment and inversely proportional to utilization (by circuit years of operation).

* In practice B also is related to the power required for a subscriber's channel relative to some nominal situation which reflects either the cost to the satellite operator for providing extra power or power "taken" from another subscriber.

Table 4.4-3. Trunk Efficiency based on Erlang "B" and "Likely" Traffic Projection Distribution

| SERVICE | NO. TRUNKS IN 2.5 MHz * | GRADE OF SERVICE | | | e, ERLANGS PEAK |
|-----------------------------|----------------------------|------------------|-------|-------|-----------------|
| | | 0.01 | 0.005 | 0.001 | |
| TRUNKING | 113 | 0.85 | 0.82 | 0.77 | 0.01 |
| RADIO TELEPHONE (15 kHz) | 120 | 0.86 | 0.83 | 0.77 | 0.03 |
| RADIO TELEPHONE (30 kHz) | 60 | 0.78 | 0.75 | 0.68 | 0.03 |

* APPORTIONED ACCORDING TO "LIKELY" TRAFFIC PROJECTION

The methodology provides a flexible method for deriving typical subscriber charges; an actual system implementation even assuming the same costs, returns on investment, etc. would result in slightly different values because actual investments, tax credits, cash flows, etc. would be considered. The methodology also provides a way to evaluate the subscriber charge effect of various system choices and characteristics; for example, should the mobile antenna be fixed or steered, is frequency reuse via orthogonal polarization important, is service bandwidth and (satellite) power important, etc. Equations 19 and 20 enable these evaluations.

With regard to Equation (19) it should be recalled that CNR and bandwidth for 4 KHz SSB, 15 KHz and 30 KHz FM signals were defined so that the total satellite power is not dependent on the mix of these. Consequently, the number of 30 KHz circuits allowable is dependent only on bandwidth, hence cost is proportional to bandwidth, e.g. to a good approximation any mix of 4, 15 and 30 KHz circuits is permissible (in actual practice each would be grouped to control intermodulation power). The demand for service in the busy hour, expressed in erlangs, is the unit of traffic intensity used in the Study. In telephone and radio telephone service, the peak to average factor P is approximately two. Somewhat larger values for P are believed characteristic for some present day terrestrial trunking services. However, considering the nature of the transportation, prospecting and government services considered

candidates for satellite service, the factor $P = 2$ may be correct (intensive activities continue beyond the normal busy hours). In any event, this is the value used throughout the study.

The factor E is a measure of trunk efficiency accomplished for a particular grade of service. In a 2.5 MHz satellite beam, the few number of available trunks leads to a significant inefficiency. In actual practice, private networks might be formed, that is, a group of 30 KHz circuits might be set aside (leased) to exclusively serve a particular network. However, the traffic intensity for a given grade of service is significantly curtailed. From the viewpoint of overall operation, this is undesirable. In this Study, a value E is derived by proportioning the radio telephone service and non-radio telephone service according to their distribution in the "likely" traffic projection, using either 15 KHz or 30 KHz for radio telephone and 4 KHz for the remainder. Values for E are tabulated in Table 4.4-3.

The factor I considers the number of available trunks that must be assigned to a given subscriber. In the system considered herein, frequency reuse is achieved via orthogonal circular polarizations. If a subscriber requires one voice circuit and his antenna axial ratio permits the use of the orthogonally polarized co-channel (actually interstitial), he is charged for one channel. However, if his antenna has a poor axial ratio, the orthogonal co-polarized channel cannot be used and he is consequently charged for two channels. This is an approximation. For example, if all subscribers have antennas with poor axial ratio, then one of the two on orbit satellites becomes a spare and the cost of one satellite can be deducted from the space segment investment. Consequently, the factor will be less than 2.

The factor F accounts for non-uniform loading of the individual satellite beams. If the beams are filled uniformly, $F=1$, if not, F is less than 1. The market studies indicate that the fill factor will depend on the ability of LMSS to penetrate the total available market.

If the market is limited to counties having population densities of 20 persons per square mile or less, the LMSS market is predominately in the western U.S. If the market is limited to non-SMSA counties, the LMSS market is predominately in the eastern U.S. Presumably something in between also is possible resulting in a beam fill factor approaching 1. Table 4.4 of the Task

1 Interim Report (Market Study) tabulates the number of subscribers per non-SMSA county for 0.5%, 1.0% and 1.5% penetration. The peak to average population ratio (fill factor F) for 100 beams is 1/3.89, 1/3.90, 1/3.70, respectively. These values pertain only if "saturating" the highest capacity beam also causes the satellite system to "saturate". In the fixed service there is a strong relationship between the highest capacity traffic node and the other nodes because all nodes communicate with the principle node.

In the mobile services, it is doubtful if such a strong relationship is valid. For radio telephone, the bulk of the service will be local (e.g. within a beam or two), and is unrelated, one area to another. For dispatch service, the causal relationship also is not apparent. It may be that an "N" beam satellite can be treated as N independent networks. Since the fill factor is otherwise large, both the carrier and subscriber may accept a lower grade of service to increase an individual beam capacity. The carrier also is motivated to keep the fill factor near unity since better utilization of the investment is achieved. He may use marketing and pricing strategies to assure the best utilization of all the beams (its hard to sell service in a saturated beam anyway), and an empty or poorly utilized beam is not providing income. A fill factor of 1 is used in the Study examples.

4.4.3.2 Subscriber Typical Charges

Table 4.4-4 describes subscriber call-minute charges for the "likely" traffic projection for the four generic dial-up services, cellular compatible radio telephone (30 KHz CFM) radio telephone (15 KHz CFM), "stand-alone" radio telephone (C-SSB) e.g. non-compatible radio telephone (or "stand-alone"), and dispatch. The narrow band modulation results in lowest charge because more channels are provided per allocated bandwidth. In fact, channel bandwidth is obviously a dominant consideration. Call minute charges for return on investment of 20% ($i = 0.2$) are attractive for all generic services when compared with non-local dial-up rates, especially when it is considered that the space segment charge is insensitive to distance. Thus, the listed charges pertain to a 20 mile "hop" or to a 2000 mile "hop", provided a gateway is available to avoid a back-haul TELCU charge.

**ORIGINAL PAGE IS
OF POOR QUALITY**

Table 4.4-4. Subscriber Call-Minute Charges for the "Likely" Market Projection (P=2, T=F=1)

| FIRST GENERATION | i = 0.2 | | | i = 0.4 | | |
|-------------------|------------------------------|-------------------|------------------------------|-------------------|------------------------------|-------------------|
| | "LIKELY" TRAFFIC UTILIZATION | ASYMPTOTIC CHARGE | "LIKELY" TRAFFIC UTILIZATION | ASYMPTOTIC CHARGE | "LIKELY" TRAFFIC UTILIZATION | ASYMPTOTIC CHARGE |
| C_s (4 kHz) | 6 ¢/MIN | 3.6 ¢/MIN | 10.5 ¢/MIN | 6.4 ¢/MIN | | |
| C_s (15 kHz) | 22.4 | 13.4 | 39.0 | 23.8 | | |
| C_s (30 kHz) | 48.1 | 28.9 | 86.0 | 52.5 | | |
| SECOND GENERATION | | | | | | |
| C_s (4 kHz) | 5.3 ¢/MIN | 3.2 ¢/MIN | 9.6 ¢/MIN | 5.6 ¢/MIN | | |
| C_s (15 kHz) | 19.6 | 12.0 | 35.7 | 20.7 | | |
| C_s (30 kHz) | 43.2 | 26.4 | 78.7 | 45.7 | | |

ORIGINAL PAGE 18
OF POOR QUALITY

Consequently, the charge for 4 KHz service, for either dispatch or "stand-alone" radio telephone is attractive. Note that the gateway charge, discussed in Section 4.5, must be added to get the total subscriber charge (mobile radio costs also are discussed elsewhere). The higher returns on investment will discourage the use of compatible radio telephone.

Table 4.4-5 describes typical monthly subscriber charges for the four generic services, for the "likely" traffic projection. Expected terrestrial, cellular radio telephone charges for typical subscribers are expected to be in the range of \$50 to \$150. A typical user price beyond \$200 is not believed to be attractive to a radio telephone user.

Table 4.4-5 indicates that SSB (or similar narrow band modulation), is attractive for either dispatch service or "stand-alone" (e.g. non-cellular compatible) radio telephone. The stand-alone radio telephone service need not be local. An RCC or WCC offering such service by satellite provides nationwide service, at these rates, to his local customers. The service is probably usable in all but the downtown sections of the very largest cities. The situation represents a satellite optimized system and is a mirror image service to the cellular system in that the "stand-alone" satellite radio telephone system works well everywhere but in the (larger) cities and the terrestrial cellular works well only near the larger cities. Subscribers will choose between them based on the subscriber's own perception of his habits and needs.

Table 4.4-5. Typical Monthly Subscriber Charge (Cm) Dollars Based on "Likely" Traffic Projection (P=2, T=F=1)

| USE | FIRST GENERATION | | SECOND GENERATION | |
|--|------------------|----------|-------------------|----------|
| | i = 0.2 | i = 0.4 | i = 0.2 | i = 0.4 |
| Cm (4 kHz) TRUNKING | \$ 13.13 | \$ 22.99 | \$ 11.60 | \$ 21.00 |
| Cm (4 kHz) STANDALONE RADIO TELEPHONE* | 33.89 | 59.30 | 29.93 | 54.18 |
| Cm (15 kHz) RADIO TELEPHONE | 147.10 | 256.10 | 128.70 | 234.45 |
| Cm (30 kHz) COMPATIBLE RADIO TELEPHONE | 315.85 | 564.75 | 283.7 | 516.8 |

* E = 1

ORIGINAL PAGE 19
OF POOR QUALITY

The 15 KHz FM, offers a barely attractive price. The 30 KHz FM service, results in unacceptably large monthly bills for typical subscribers (.03 erlangs peak), however this is not the whole story. While it is now apparent that 30 KHz FM is not particularly attractive for use with the "spectrum-starved" satellite system, its use in conjunction with the cellular system will still be attractive to some subscribers. For example, the cellular subscriber (with satellite "compatibility") will use the cellular system almost exclusively, and will, therefore, reap the benefits of its economical charge (\$50 to \$150 per month). However, when he roams outside the cellular system, needs wideband data service, or desires to place a long distance call, the cellular compatible satellite charge is still less than the telephone rates, particularly for long distances. The subscriber, of course, must anticipate these extended uses by modifying his mobile unit for satellite use.

All four services will likely emerge and become important in an evolving system driven by market forces.

Note that the dispatch service monthly charge benefits from two principle factors, (1) the bandwidth factor and the average use (.01 erlangs in the busy hour). Considering that there are many applications for such services in the transportation and mineral industries, and in government services (disaster relief, search and rescue, etc.), these markets can be well served by satellite (there are no real terrestrial alternatives).

Wideband data also can be provided. A 56KBPS link can be provided (based on the "likely" traffic projection, second generation system, $P=2$, $T=F=1$) at approximately 96 cents per minute or \$210 per month at .01 erlangs, peak, using quadrature PSK, assuming telephone-like characteristics for the user. A 4.8 KBPS link, using quadrature PSK (a dial-up 4 KHz circuit), also is possible at about the prices developed for 4 KHz C-SSB voice. While too complicated to discuss in detail, herein, the price for data ought to be higher than for voice for the same bandwidth and power because of the continuous transmission characteristics (e.g. no VOX).

The interactive data/position location service is also of interest. At a 6 KBPS rate (4 KHz bandwidth) a 250 bit block can be transmitted in .04 seconds. Allowing for sync, transmission inefficiency and coding, a message

block costs (.05 seconds x 6¢/minute) = .005¢/minute) = .005¢ per message block if the channel is fully utilized. Somewhat higher charge may be needed if a simple antenna is used (a poor axial ratio doubles the cost because the orthogonally polarized channel is not allowed) and to allow for continuous, non-VUX operation. Also, two channels (one on each satellite may be needed - this need not increase the charge if both channels are fully utilized). Also two trunks per connection are needed, one between the mobile and NOC and another between the NOC and the "dispatcher". Considering, all of these factors about .03¢ a message block is an approximate charge for the space segment. For an average of two messages per day (including an occasional position location measurement, the monthly charge per mobile is 1.8¢/month. The cost of data processing must be added to this.

The gateway cost, if dedicated to this type of service is a significant cost. Consider, as an example, a simple fixed tuned gateway (no dial-up services) operating exclusively in the interactive data mode. At a nominal installed cost of \$100,000, 10 year life, 10% interest, 5% annually for O & M, the gateway annual cost is \$26,381 or \$2,198 per month. If the dispatcher is handling a fleet of say 100 trucks, the cost of service is about \$22/month per truck. Of course, if the gateway also is used for other purposes, such as dial-up voice or data, (or shared for CATV distribution, etc.), the shared cost can be considerably less. The conclusion is that the interactive data/position service, (basically a packet network), is inexpensive with regard to space segment and gateway charges for fleet use, provided the alpha-numeric messages to and from the mobile can be structured to be cost effective to the service. Outgoing messages to the mobile can provide hard copy routing messages, (weather and highway conditions, etc.) whereas return messages can consist of cargo/trailer status and location. The mobile transceiver should be inexpensive, using a fixed antenna, single channel (untuned) transceiver with low speed MODEM and CODEC.

Table 4.4-6 describes call-minute charges and Table 4.4-7 describes monthly subscriber charges for the "optimistic" traffic projection. These charges are less than those previously shown (for the "likely" case) because of the higher traffic demand. However, the 10-15% lower values are all in proportion to those previously discussed, and the absolute values do not alter the comments and observations concerning service viability and market "niches" previously discussed.

Table 4.4-6. Subscriber Call-Minute Charge for
 "Optimistic" Traffic Projection
 (P=2, T=F=1)

| | i = 0.2 | | | i = 0.4 | | |
|-------------------------|---------------------------------|-------------------|---------------------------------|-------------------|---------------------------------|-------------------|
| | "OPTIMISTIC" TRAFFIC PROJECTION | ASYMPTOTIC CHARGE | "OPTIMISTIC" TRAFFIC PROJECTION | ASYMPTOTIC CHARGE | "OPTIMISTIC" TRAFFIC PROJECTION | ASYMPTOTIC CHARGE |
| FIRST GENERATION | | | | | | |
| C _s (4 kHz) | 5.2 ¢/MIN | 2.9 ¢/MIN | 9.9 ¢/MIN | 5.06 ¢/MIN | | |
| C _s (15 kHz) | 19.4 | 10.6 | 36.5 | 19.09 | | |
| C _s (30 kHz) | 42.8 | 23.4 | 80.5 | 42.1 | | |
| SECOND GENERATION | | | | | | |
| C _s (4 kHz) | 4.70 ¢/MIN | 3.0 ¢/MIN | 8.29 ¢/MIN | 5.06 ¢/MIN | | |
| C _s (15 kHz) | 17.4 | 11.0 | 30.7 | 19.0 | | |
| C _s (30 kHz) | 38.4 | 24.2 | 67.7 | 42.1 | | |

ORIGINAL PAGE IS
 OF POOR QUALITY

Table 4.4-7. Typical Monthly Subscriber Charge, Dollars,
 Based on "Optimistic" Traffic Projection,
 (P=2, T=F=1)

| USE | FIRST GENERATION | | SECOND GENERATION | |
|--|------------------|----------|-------------------|----------|
| | i = 0.2 | i = 0.4 | i = 0.2 | i = 0.4 |
| Cm (4 kHz) TRUNKING | \$ 11.38 | \$ 21.67 | \$ 10.29 | \$ 13.15 |
| Cm (4 kHz) STAND-ALONE RADIO TELEPHONE * | 29.36 | 55.91 | 26.55 | 33.92 |
| Cm (15 kHz) RADIO TELEPHONE | 127.40 | 239.70 | 114.25 | 201.60 |
| Cm (30 kHz) RADIO TELEPHONE | 281.05 | 528.65 | 252.15 | 444.55 |

* E = 1

Table 4.4-8 describes subscriber call-minute charges and Table 4.4-9 describes monthly subscriber charges for the "conservative traffic projections." These charges are significantly higher because, for this case, the lower subscriber base is more significant than the decreased satellite costs.

The dispatch and stand-alone radio telephone systems are still attractively priced, at least at the lower investment return (20%). The cellular compatible radio telephone has both high call minute and monthly charges but is probably still attractive particularly at the lower investment return (20%), as discussed previously. The first generation satellite for this case has 9 beams and a 55' UHF antenna, considerably beyond the state of the art for 1987, the first year of annual operation.

4.4 4 DISCUSSION AND INTERPRETATION OF RESULTS

4.4.4.1 Introduction

Section 4.4.3 described typical cost results for the postulated markets (optimistic, likely and conservative), for the postulated services (cellular compatible and stand-alone radio telephone, dispatch, and interactive data-position location) for a multiplicity of derived and assumed parameters (e.g. spacecraft cost vs. power, mobile antenna gain, peak to average factor, mobile noise temperature, etc). Methods were described for computing call

Table 4.4-8. Subscriber Call-Minute Charge for "Conservative"
Traffic Projection (P-2, F=F=1)

| | i = 0.2 | | i = 0.4 | |
|--------------------------|---------|------------|---------|------------|
| | LIKELY | ASYMPTOTIC | LIKELY | ASYMPTOTIC |
| FIRST GENERATION | | | | |
| C _s (4 kHz) | 9.3 | 6.3 | 16.80 | 11.6 |
| C _s (15 kHz) | 34.4 | 24.4 | 62.3 | 43.2 |
| C _s (30 kHz) | 76.1 | 54.2 | 137.3 | 95.2 |
| SECOND GENERATION | | | | |
| C _s (4 kHz) | 8.06 | 5.7 | 14.6 | 10.1 |
| C _s (15 kHz) | 29.9 | 21.3 | 54.0 | 44.8 |
| C _s (30 kHz) | 65.9 | 46.9 | 119.0 | 82.4 |

minute charges and monthly charges. The reader therefore is provided a methodology so he may compute his own array of system charges for whatever situation can be envisioned. Of course, the methodology developed is not unique, and alternative methods also can be used. It is believed that the results are sufficiently accurate and sufficiently representative of operational system costing (and pricing) methodology that the previously described results can be used to evaluate the significance of the results and the importance (or lack of importance) of various system parameters. This section, therefore, is an interpretation of those results believed to be important.

4.4.4.2 Space Segment Investment

Space segment investment is, for all intents and purposes, directly related to the subscriber charges (small variations are due to the two payback schedules). However, the space segment investment consists principally of satellite recurring and non-recurring costs and launch vehicle costs. While the estimates are as accurate as can be expected of the modeling procedure, that is, within 20%, large differences may arise due to the procurement conditions actually existing. For example, if more than one system is

Table 4.4-9. Typical Monthly Subscriber Charge, Dollars
Based on "Conservative" Traffic Projection,
(P=2, T=F=1)

| USE | FIRST GENERATION | | SECOND GENERATION | |
|--|------------------|----------|-------------------|----------|
| | i = 0.2 | i = 0.4 | i = 0.2 | i = 0.4 |
| Cm (4 kHz) TRUNKING | \$ 20.35 | \$ 36.78 | \$ 17.65 | \$ 31.96 |
| Cm (4 kHz) STAND-ALONE RADIO TELEPHONE | 61.07 | 110.33 | 52.93 | 95.88 |
| Cm (15 kHz) RADIO TELEPHONE | 225.91 | 409.13 | 196.4 | 354.6 |
| Cm (30 kHz) COMPATIBLE RADIO TELEPHONE | 499.75 | 901.65 | 432.75 | 781.50 |

procured, such as one for the U.S. and one for Canada, or possibly a multibeam INMARSAT (maritime mobile satellite), the non-recurring cost could be significantly less. In addition, if a standard low cost trans-stage is not available, the cost for launching also can be significantly higher. These uncertainties are believed to dwarf the errors in the modeling. It should also be noted that Concept D is not capable of launch with the present Shuttle configurations.

Another consideration is that the present Study did not include detailed satellite concept design or optimization. It is believed that the optimization procedure in particular might be significant. For example, Concept D makes use of full-on-board FDMA routing and switching - perhaps a partial switching capability might serve. Concept D' requires high power because of non fading at Ku Band - perhaps adaptive power control, use of larger gateway antennas or the use of several Ku Band beams with a modicum of switching could reduce satellite weight significantly.

Finally, component weights and powers are based on present usage and expectations and lower values might be obtainable with R&D. For example, the narrow frequency separation between UHF (and S-Band) receivers and transmitters results in stringent filter requirements, not only for diplexing but also for "notching" the transmitter intermodulation noise that lies within

the receive band. Metallic filters were assumed although graphite-epoxy composite material might save considerable weight. In the multiple beam satellites in particular, the weight of filters and switches (for ring redundancy) was significant. The weight of UHF power amplifiers was always insignificant because of the low powers postulated and the high power capability per device. As noted previously, the on-board (SS-FDMA) channelization and switching system for full flexibility, for a 100 beam satellite requires substantial weight and power. R&D might reduce these effects significantly. The weight of the multi beam antenna based on previous detailed studies and on R&D is believed to be representative. The results of the above considerations is believed to have resulted in conservative estimates of spacecraft weight and cost.

Space segment cost versus capacity, Figure 4.4-1, has several inflections and features worth noting. First, over the 10 dB range in UHF power considered, spacecraft weight (and cost) was little affected except for the (low gain) single beam, or "few beam" cases. Starting from Concept A, the 1 beam case, satellite weight and costs escalate rapidly with capacity, because of the substantial increase in antenna weight and transponder weight required for multiple beam operation, particularly for the lower powers. Over the middle range, to about 31 beams, (the largest capacity attainable with a single beam S-Band Fixed Services link) cost versus capacity increases more slowly (see the slope = 1/2 line). Power over the range considered is not important, and weight is increasing more or less in proportion to the number of antenna beams. For greater than 31 beams, the cost versus capacity slope again increases due to the affect of the fixed services link. Two cases were examined, one made use of multiple S-Band beams (to generate the necessary bandwidth) coupled with on-board FDMA routing and switching, and the other made use of a single Ku Band beam with no on-board switching. In the latter case, power increased substantially because of the use of a single (lower gain) antenna beam, rain attenuation and attendant increase in sky noise, and a higher receiver noise figure. In this region, a slope of approximately one means that the system has lost its "economy of scale" and space segment costs will be independent of capacity. Several suggestions are offered to reduce costs in these regions:

1. Increase gateway antenna size.
2. Add multiple beam Ku Band capability.

ORIGINAL PAGE 13
OF POOR QUALITY

3. Add downlink (Ku Band) power diversity.

It is probably undesirable to increase the antenna diameter because of added antenna costs and costs for antenna tracking. As described subsequently, low gateway costs are a key element in both the economy and flexibility of a mobile satellite system. Multiple Ku band beams requires routing between the beams, probably using switching. This enables a better balance between satellite weight and power; this method is probably preferred. The third method, using downlink power diversity, requires UHF uplink power diversity at the mobile and is not likely to be desirable, particularly with low gain mobile antennas, due to excess power amplifier requirements.

Finally, other access methods besides FDMA can be considered. TDMA with on board processing might have some advantages despite lack of compatibility with existing terrestrial systems and equipment. In this method the uplink is TDMA, and an on-board processor demodulates, decodes, buffers and switches these TDMA bursts so as to form TDMA downlink streams, with all traffic only in the correct beams. Low speed TDMA in the uplink is required to limit the mobile amplifier power. Signalling can be accomplished as described herein.

A user, requesting service, is assigned a TDMA slot which is routed via the satellite processor, to the correct downlink beam, for reception. When the call is completed, the TDMA slot is available for another user.

Such a system has some challenging aspects. Besides lack of compatibility, present methods for digitally encoding near-toll-quality voice at reasonable costs, such as delta modulation, require significant bit rates - approximately 32 KBPS (20 KHz noise bandwidth for quadrature PSK). As a result more satellite beams (compared to SSB) will be required to generate the same capacity. Mobile power also must increase in order to support the uplink "burst"; a 400 KBPS burst results in a 12.5 times increase in mobile HPA power.* The mobile must then use a more expensive burst MODEM and CODEC, and have TDMA timing equipment. It is not obvious that space system costs have

*

Mobile power is limited by radiation considerations.

been reduced since the effect of the wider channel bandwidth requires more antenna beams. Thus while the space segment may have benefitted by lower weight and cost, mobile equipment costs have also increased significantly. A detailed study is needed to examine the attractiveness of this system.

4.4.4.3 Fixed Link Operation

Use of S-Band is desirable because the lower tolerances should reduce gateway equipment and installation costs and enable more reliable and efficient (linearized) satellite amplifiers. However, there are several disadvantages to the use of S-Band. Lack of earth station activity in the band will certainly increase prices. The satellite antenna is certainly larger. However, a more fundamental objection is the unacceptable interference generated in the satellite up link by the terrestrial services in this band, particularly ITFS. This subject is discussed more fully in Section 4.5. It appears that Ku Band is the best alternative. This band will make extensive use of small earth stations (including low cost DBS earth stations in the adjacent BS band). Terrestrial coordination is minimized and orbital slots can still be reserved for an LMSS. Rain fading is a problem but relatively low availability requirements (say 0.999) minimize this problem. Efficient orbital utilization can be attained if the mobile satellite either contains the required number of Ku Band transponders for fixed (non-LMSS) service operation or is co-located with a Ku Band fixed services satellite such that the total available band is used by the combination.

4.4.4.4 Power and Margin

For the first generation system satisfying the "likely" market projection, a capacity of 38,000 circuits results in a space system cost that varies only 6% over a 10 dB power range. This difference is very significant for low capacity (1 beam) satellites but totally insignificant for the very high (100 beam) satellites.

For the case of electronically or mechanically steered antennas, with a projected on axis gain of approximately 10 dB (which was the basis for the so-called "nominal" link) it appears easy to provide an additional 10 db margin. Since quality in the "nominal" link was acceptable (for mobile services) to begin with this margin may be used to assure service under stressed conditions, that is, in situations such as those encountered in urban areas where severe multipath from buildings and man made noise from

automobiles is encountered. The principle virtue of the steered antennas is in their ability to reject multipath and noise. While it is difficult to quantify this advantage in the complex urban environment, the effectiveness of the antenna (it is recognized that "effectiveness" in the context is somewhat subjective) is roughly proportional to the gain, relative to the lower gain alternatives. It is apparent that such antennas are advantageous to LMSS particularly for operation in suburban and urban areas. In addition, the large margin also can reduce and may accommodate the fading due to some forms of shadowing, like trees. In summary, the steered antennas allow

1. A large fade margin
2. better suppression of multipath and noise
3. Better axial ratio (over the limited beamwidth) in order to reject the unwanted polarization.

The cost of these antennae may be the principle objection. However, a 10 dB gain antenna has a 3 dB beamwidth of about 55 degrees. Consequently, steering need not be precise, and only steering in azimuth is required. Either a rotary joint or "wrap around" cable can be used for the mechanically steered antenna. A simple inexpensive steering method is "step track" using the satellite system common signalling channel carrier as a reference. In this method, the carrier level is measured and stored, the antenna is stepped in azimuth and the new carrier level measured and compared with the previous value. If the level has increased, another step is taken in the same direction. If the level has decreased, a backward step is taken, etc. The cost of the mechanically steered antenna, while certainly greater than that of a fixed antenna should be acceptable, particularly for dispatch applications. The yagi (or similar structure) with radome is simple to manufacture (it is a favorite low cost TV antenna), a stepper motor also is inexpensive and the step track processor trivial. The electronically steered antenna also is inexpensive to manufacture* except possibly for the phase shifter diodes.

**ORIGINAL PAGE IS
OF POOR QUALITY**

* The reader is referred to Section 4.6.2 for a complete discussion of these antennas.

The low gain antennas for vehicles or pedestrians or both are lightweight and relatively compact with effective gains 6 to 10 dB less than the steered antennas. Thus, additional margins can be provided for these types also. However, the ability of these antennas to suppress ground skip and ground (thermal) noise, building multipath and man made noise is considerably less. Such antennas are strongly coupled to their environment, the beam (or null) shaping capability is limited and poorer axial ratio over the larger beamwidth is a certainty. It is apparent that axial ratios exceeding 4 dB may be experienced. Isolation, assuming an ideal satellite antenna, versus axial ratio is plotted in Figure 4.4-7, indicating that axial ratios of 4-5 dB result in only 10 dB of total isolation. This may be sufficient if additional isolation is obtained via interstitial spacing and companders are used. Reference (1) describes isolation characteristics (corresponding to a signal to interference ratio of 20 dB) of amplitude compandored SSB. At 2 KHz offset the worst case isolation corresponds to two interfering SSB carriers whose total power is 14 dB greater than the wanted signal or a total isolation of 34 dB. The interference is negligible. Reference (1) also describes isolation characteristics of compandored FM. At 15 KHz offset, the worst case isolation for two interfering FM carriers is about 34 dB; coupled with 10 dB antenna isolation the interference is completely negligible. It appears, therefore, that the poorer axial ratio will not prevent frequency re-use with orthogonal polarizations, provided companders are used. The antennas still have limited ability to reject multipath and noise, however.

With a nominal mobile antenna gain of 3 dB a margin of only 3 dB is obtained over the case of nominal performance plus 10 dB. The 10 dB increase in power is obtained by a cost increase of 6% as described previously. To explore the cost of larger margins Concept C was examined for the case of 17 dB more UHF power than the nominal case. The UHF transmitter weight and power system weights were then computed. Total power (Concept C3) increases to 6550 watts and total weight to 5024 pounds.

Figure 4.4-8 depicts space segment investment versus spacecraft weight for the 15 concepts (D and D' each resolve into a point) or 5 concepts at 3 power levels.

ORIGINAL PAGE 13
OF POOR QUALITY.

ORIGINAL PAGE IS
OF POOR QUALITY

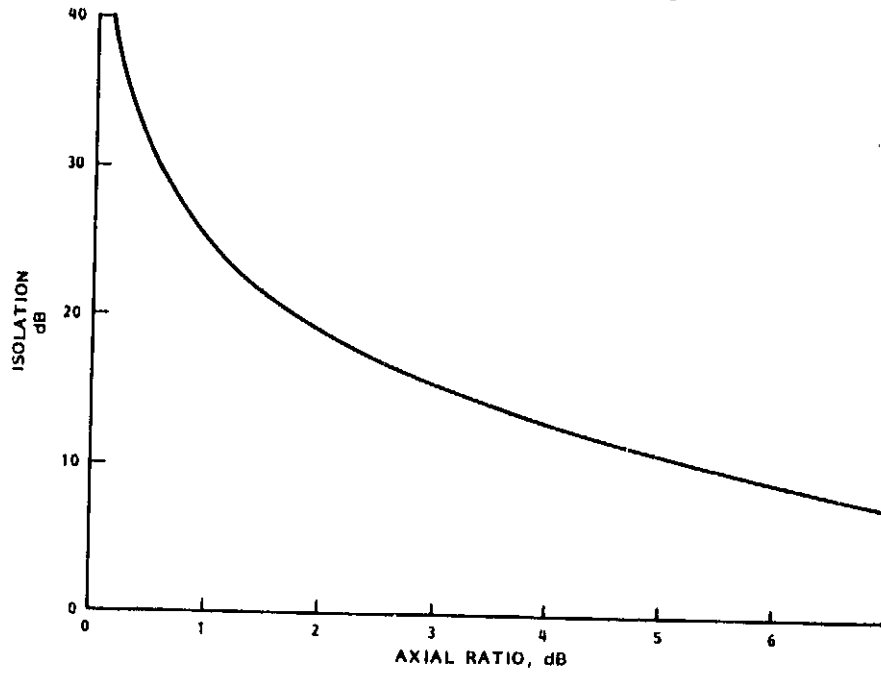

Figure 4.4-7. Isolation versus Axial Ratio

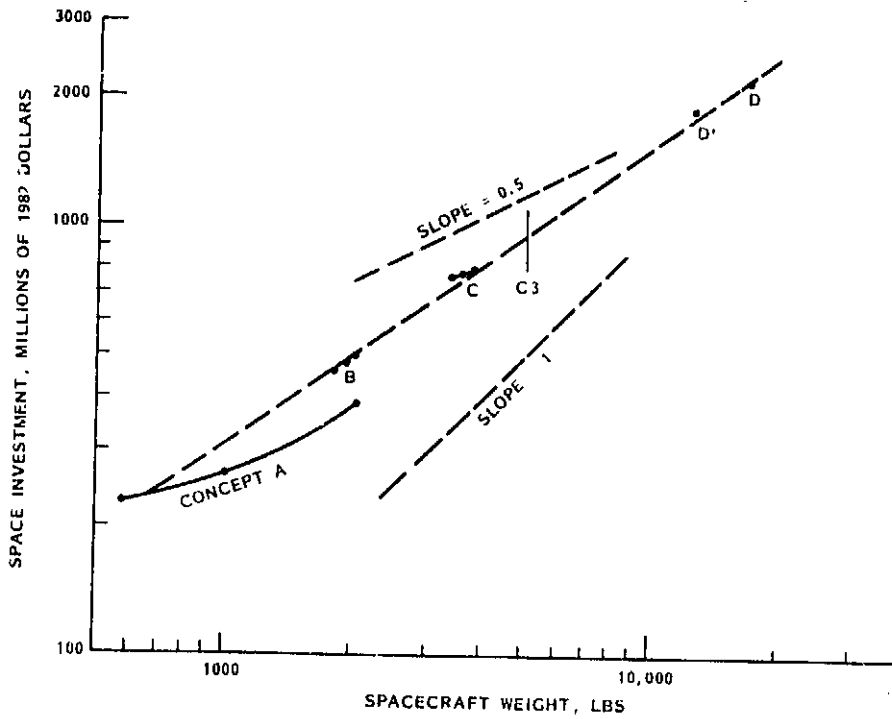

Figure 4.4-8. Space Segment Investment vs. Spacecraft Weight

Spacecraft costs are treated as a continuous function by the dashed "trend" line. Based on this trend, Concept C3, with a mass of 5000 pounds, costs \$950M compared to Concept C which costs \$760M or a change of 25%. Since investment is directly related to Subscriber charges (almost exactly) a 10 dB margin for a fixed antenna system with a useful gain of about +3 dbi requires an increased subscriber charge of 25%, (compared to 6% for the steered antenna). Referring to previous results in Table 4.4-5, a 6% increase in the stand-alone monthly radio telephone service charge is \$2.03 per month; for compatible radio telephone it is \$18.95 per month. For 10 year equipment life and 10% interest, these monthly charges are equivalent to an investment of \$150 for the stand-alone radio telephone and \$1397 for compatible radio telephone.

Referring again to Table 4.4-5, a 25% increase in the stand-alone monthly radio telephone service charge is \$8.47 and \$78.96 for the compatible radio telephone. These charges are equivalent to investments of \$885 and \$5822. These charges may help us to discover subscriber strategies with regard to margins.

For example, consider a stand-alone radio telephone subscriber with a fixed low gain antenna (assume 0dbi). He requires 10 db more power to attain the nominal link performance. He can pay 6% more or \$2.03 per month for increased power. Alternately, we can recognize that the charge is equivalent to an investment of \$150 (\$244 if the time span is forever). Therefore, if the installed cost of the steered antenna is less than \$150 (\$244 if he takes the long view), he will prefer the steerable antenna (and get better performance with regard to multi path and man made noise). The mechanically steerable antenna is expected to cost considerably less than \$150. If he is a cellular compatible subscriber the steerable antenna is obviously always a better economic choice.

This conclusion is not valid for everyone. If the mobile operates only in the interactive data mode, or if the voice mode entails only occasional use (less than .01 erlang) he will likely prefer the fixed antenna.

In conclusion, it appears economic for heavy users to prefer the more expensive steerable antennas and light users to prefer the less expensive fixed antenna. For this reason, it may be expected that varieties of mobile

antennas will actually be used depending on the service use. Mobiles expected to penetrate suburban and urban areas with reliable communications (except for shadowing) will likely prefer the higher performance steerable antennas.

4.4.4.5 Modulation and Channel Bandwidth

As described previously, narrowband modulation systems such as compandored SSB are attractive for use with satellite systems, offering low cost, no threshold operations, intelligibility at faded signal levels and considerable resistance to co-channel and adjacent channel interference. With SSB, the system design must provide a means for AGC (done via the common signalling channel in stand-alone systems) and AFC which is provided via a modulated reference carrier transmitted along with the audio. Compandored SSB quality is acceptable for mobile services.

Use of 15 KHz compandored FM also is attractive, however, lower bandwidth is even more attractive. A combination of over deviation (deviation exceeding Carson's rule) and narrowband filtering, might reduce the center to center spacing to 10 or 12 KHz, thereby reducing cost.

This topic is explored in Reference (2) in the context of a terrestrial mobile radio system. Good results are reported for a so called 12.5 KHz PM system (FM) with ± 2.5 KHz peak deviation, 0.3 to 2.6 KHz audio in an IF bandwidth of 7.5 KHz. No compandors are used, (the report also discusses the relative merits of other modulation methods such as SSB and compandored SSB and FM).

The problem of compatibility (e.g. cellular compatibility) also is an important issue. It is apparent that considerable penalties in cost and performance are imposed on the LMSS by compatibility. The present cellular design evolved by optimizing the system to obtain best threshold performance and costs. The cellular system is basically a short range adaptive mobile radio system (limited by 4 watts transmitter power). Therefore, it is not surprising that an optimized satellite system with good performance and cost uses quite different parameters. LMSS should evolve in a way where these parameters can be used, hence the stand-alone dispatch and radio telephone systems described herein.

What is surprising is the ability of the satellite to work at all with the terrestrial parameters. For example, a minimum cellular terrestrial mobile requires only an improvement in noise figure. With +10 db more UHF satellite power, and a linear polarized monopole (with a gain of +2 dbi, and a 3 db loss for circular to linear polarization conversion), the performance is 1 db poorer than the nominal link (NF = 1 db). The antenna temperature also is considerably poorer. Still, it appears that the link is above the FM threshold. This operation is marginal at best, and is not recommended, however, it might have some uses for cellular subscribers desiring minimum modifications, (note other modifications such as to provide VOX operation also are required).

4.4.4.6 Pedestrian Antenna

In the terrestrial system considerable convenience is afforded to some subscribers who can remove the mobile radio from the vehicle and use it while outside the vehicle. A special antenna and batteries are required, and of course the batteries are recharged when the radio is returned to the vehicle. Police, building contractors, emergency service and search and rescue activities, etc. find this convenient, and, of course, the service is short range so that little power and a convenient (collapsible) antenna is possible.

For LMSS, this concept requires modification because of the long range to the satellite. As discussed previously, a whip antenna might conceivably be used. A 17 db increase in satellite power overcomes a 13 db loss in antenna gain, (compared to the steered antenna) providing something less than 4 db better performance than the nominal case (the antenna noise also is considerably higher). The subscriber pays approximately 25% more for the power increase (as discussed previously) which is perfectly acceptable if narrowband modulation is used. However, performance will be poor because of multipath (fades of 20 to 35 dB depending on where the subscriber is standing and how he is moving). Man made (ignition) noise also may be troublesome if he is in a suburban or urban location. Consequently, the antenna, while convenient, will result in poor service. A major improvement can be realized by the use of a small circularly polarized antenna. Section 4.6.2 describes an example, a drooping dipole antenna and "cup". The assembly is made of metallized plastic rods and metallized foam cylinders (for the "cup") to

provide a light weight assembly, all covered by surface hardened foam. A telescoping supporting mast and a flexible coaxial cable completes the assembly. The assembly is very lightweight and reasonably convenient. For a satellite system having most subscribers in rural/remote or suburban areas applications for pedestrian type mobile radio will emphasize government and business applications; examples are search and rescue teams, fire fighters, agricultural communications, etc. and not consumer oriented radio telephone. Viewed in this light the drooping dipole antenna provides a good compromise between performance and cost.

REFERENCES

- (1) UHF Task Force Report, "Spectrum Efficient Technology For Voice Communications", Bruce Lusignan (Technical Report #22)., Stanford University, February 1978.
- (2) Modulation Technique for Land Mobile Radio by F. Hansen, Storno A/S (Denmark) Report FH 5100.

4.5 GATEWAY TERMINALS

4.5 GATEWAY TERMINALS

4.5.1 INTRODUCTION

The fixed link portion of the mobile communication may be accomplished either at Ku Band or S-Band by the "Gateway" terminals. These are small earth stations located on or near the premises of mobile operators; these premises may be a local telephone exchange, a dispatcher, a "command post", or a central computer for data processing. It is important for the gateway terminals to be low cost despite the sophisticated functions that are needed to be performed. Envisioned as using generic SCPC (single channel per carrier) format and full demand assignment the gateway responds to a common signalling channel and via a frequency synthesizer, tunes to the correct channels for reception and transmission. The gateway is, therefore, equipped to satisfy the requirements of the local operator. It is not clear at this moment, nor is it important for the conduct of the study, who owns the gateway terminals. These can be owned by the local operator or leased by the system operator.

The cost of the gateway terminal determines its importance in the network. If the gateways were very expensive for example, the system might have just one gateway, and all fixed link signals distributed to and from the gateway by the national telephone network. Such an operation incurs large, long-distance telephone charges. Alternatively, each operator can have a gateway in which case the national telephone system is used only for the local distribution of the mobile telephone service, and occasionally for long distance via the TELCO.

If the gateways are distributed evenly over the U.S., the number of gateways N , versus half the distance between gateways is the following:

| <u>N</u> | <u>D, Miles</u> |
|----------|-----------------|
| 10 | 272 |
| 100 | 86 |
| 1000 | 27 |
| 10000 | 9 |

At least a thousand terminals are needed to eliminate long haul toll charges.

The implications of such an arrangement can be examined by considering the cost to connect an operator to a nearby gateway. As illustrated in Figure 4.5-1, the outlying operators (who could be a radio common carrier, another wireline carrier, a dispatcher, or a computer facility, etc.), can connect to the gateway located at the TELCO exchange using dialed or leased TELCO lines, radio relay or another gateway. The choice depends on the relative cost of each of these connecting facilities, the distance, and the operator's anticipated local traffic, which is assumed to be voice.

For traffic intensity computations erlang "B" is used with a peak to average load factor of 2:1.

4.5.2 DIAL-UP TELEPHONE

In this arrangement, the voice traffic, received by the central TELCO via its gateway is distributed by the dial-up telephone network to the destinations in its vicinity. Unfortunately, there are lots of choices in telephone rates for medium range distances. The most expensive, given in Table 4.5-1 is for the AT&T long distance, day-time rate (which, however, is relatively distance insensitive over the ranges of interest).

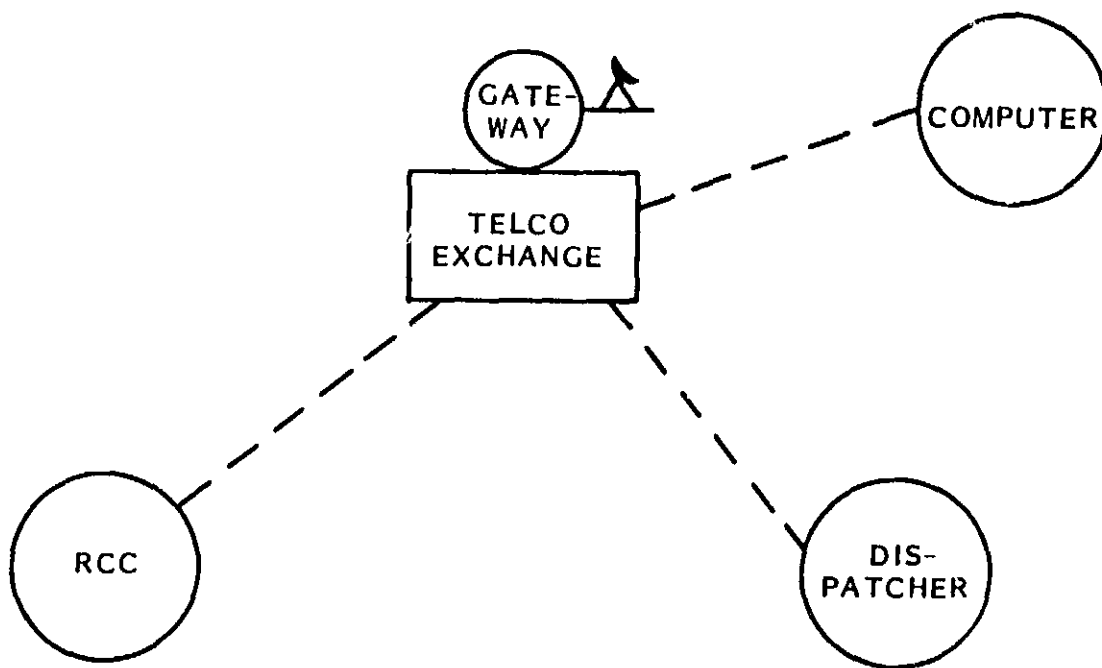

Figure 4.5-1. Concept for Satellite Access via a Gateway Terminal

Table 4.5-1. Typical Dial-Up Long Distance Rates

| | <u>Approximate Mileage</u> | <u>1st Min. Rate ¢/Min.</u> | <u>2nd Min. Rate ¢/Min.</u> | <u>Avg. 1.6 Min. ¢/Min.</u> |
|---------------------------|--------------------------------|-------------------------------------|-------------------------------------|---------------------------------|
| Philadelphia - NYC | 95 | 57 | 37.4 | 50 |
| Philadelphia - Binghamton | 140 | 58.6 | 39.4 | 51.4 |
| Philadelphia - Cleveland | 338 | 59.6 | 42.4 | 53 |

WATS (Wide Area Telephone Service) rates are cheaper but more complex. Table 4.5-2 is a schedule for WATS for Band 1 which, for a company quartered for example, in Philadelphia, extends to New York, New Jersey, Connecticut, Delaware and Maryland - distances up to 350 miles. Table 4.5-3 is a schedule for Band 2 which extends to approximately 500 miles.

Table 4.5-2. Incoming/Outgoing WATS Charges for Band 1

(Philadelphia to New York, New Jersey, Connecticut, Delaware, and Maryland - approximately up to 350 miles); Line charge, incoming (minimum) - 2 x \$36.80/mo., outgoing \$31.65/mo.

| <u>Hours Used</u> | <u>INCOMING/OUTGOING</u> | | |
|-------------------|--|--|--|
| | <u>Busy Hours 8 a.m. - 5 p.m. ¢/Min.</u> | <u>Evening 5 p.m. - 11 a.m. ¢/Min.</u> | <u>Night 11 p.m. - 8 a.m. ¢/Min.</u> |
| 0 - 15 | 30.3/29 | 22.0/18.9 | |
| 15 - 40 | 27.7/25.8 | 19.9/16.8 | 14/10.1 |
| 40 - 80 | 25.1/22.6 | 18.1/14.7 | |
| 80+ | 22.2/19.1 | 16.0/12.4 | |

Table 4.5-3 Incoming/Outgoing WATS Charges for Band 2

(Philadelphia to Ohio, West Virginia, North Carolina, Vermont, Massachusetts, New Hampshire, Rhode Island - approximately up to 500 miles), line charges given in Table 4.5-2.

| INCOMING/OUTGOING | | | |
|-------------------|---------------------------|----------------------------|----------------------------|
| Hours Used | Busy Hours | Evening | Night |
| | 8 a.m. - 5 p.m. ¢/Min. | 5 p.m. - 11 a.m. ¢/Min. | 11 p.m. - 8 a.m. ¢/Min. |
| 0 - 15 | 30.9/32.3 | 22.3/3/21 | |
| 15 - 40 | 28.3/28.7 | 20.3/18.7 | 14.7/11.2 |
| 40 - 80 | 25.6/25.2 | 18.4/16.4 | |
| 80+ | 22.6/21.3 | 16.3/13.9 | |

There are also different rates within a state. Pennsylvania, for example has a limited charge service, restricted to Eastern Pennsylvania for both large and small businesses, and an unlimited state-wide charge service, for large and small businesses. These cover significant distance since this state is 290 miles by 160 miles. Presumably other states have similar services although it is expected that rates in the west will be somewhat higher because of the lower population density. Tabulated in Table 4.5-4 and Table 4.5-5, the small business rates are favorable for less than 10 hours of service and the large business rates are favorable for greater than 180 hours of service. These lines are dial-up.

The results, displayed in Figure 4.5-2 show the day-time cost per minute versus erlangs for the various TELCO services. WATS, Bands 1 and 2 show costs 30 to 40¢ per minute for intensities greater than 1 erlang.

Table 4.5-4. Pennsylvania Limited Coverage (East) TELCO Rates
For Small and Large Business Services

| <u>Call Direction</u> | <u>Maximum Hours</u> | <u>Rate for Max. Hrs. ¢/Min.</u> | <u>Rate for Exceeding Hrs. ¢/Min.</u> | <u>Service Types</u> |
|-----------------------|----------------------|----------------------------------|---------------------------------------|----------------------|
| Incoming | 10 | 0.4 | 14.8 | Small Business |
| Outgoing | 10 | 0.3 | 13.9 | Small Business |
| Incoming | 180 | 1.7 | 3.8 | Large Business |
| Outgoing | 180 | 1.6 | 3.3 | Large Business |

Table 4.5-5. Pennsylvania - Wide Coverage TELCO Rates for Small
and Large Business Services

| <u>Call Direction</u> | <u>Maximum Hours</u> | <u>Rate for Max. Hrs. ¢/Min.</u> | <u>Rate for Exceeding Hrs. ¢/Min.</u> | <u>Service Types</u> |
|-----------------------|----------------------|----------------------------------|---------------------------------------|----------------------|
| Incoming | 10 | 0.5 | 26.5 | Small Business |
| Outgoing | 10 | 0.4 | 24.8 | Small Business |
| Incoming | 180 | 2.4 | 4.7 | Large Business |
| Outgoing | 180 | 2.1 | 4.2 | Large Business |

Below 1 erlang intra-state rates or WATS or dial-up may be used depending on the local telephone services available. The dial-up network, of course, sets an upper bound on the costs particularly at light traffic loads. Small business service, if available, is cost effective below 0.1 erlangs.

The telephone network is one method for distributing the mobile signals from a distant gateway.. Other methods are examined in the following sections.

4.5.3 LEASED LINES

In this case, a connection from the gateway to the operator's premises is provided by leased lines. The operator then provides manual or automatic switching to connect the calls to a local resident.

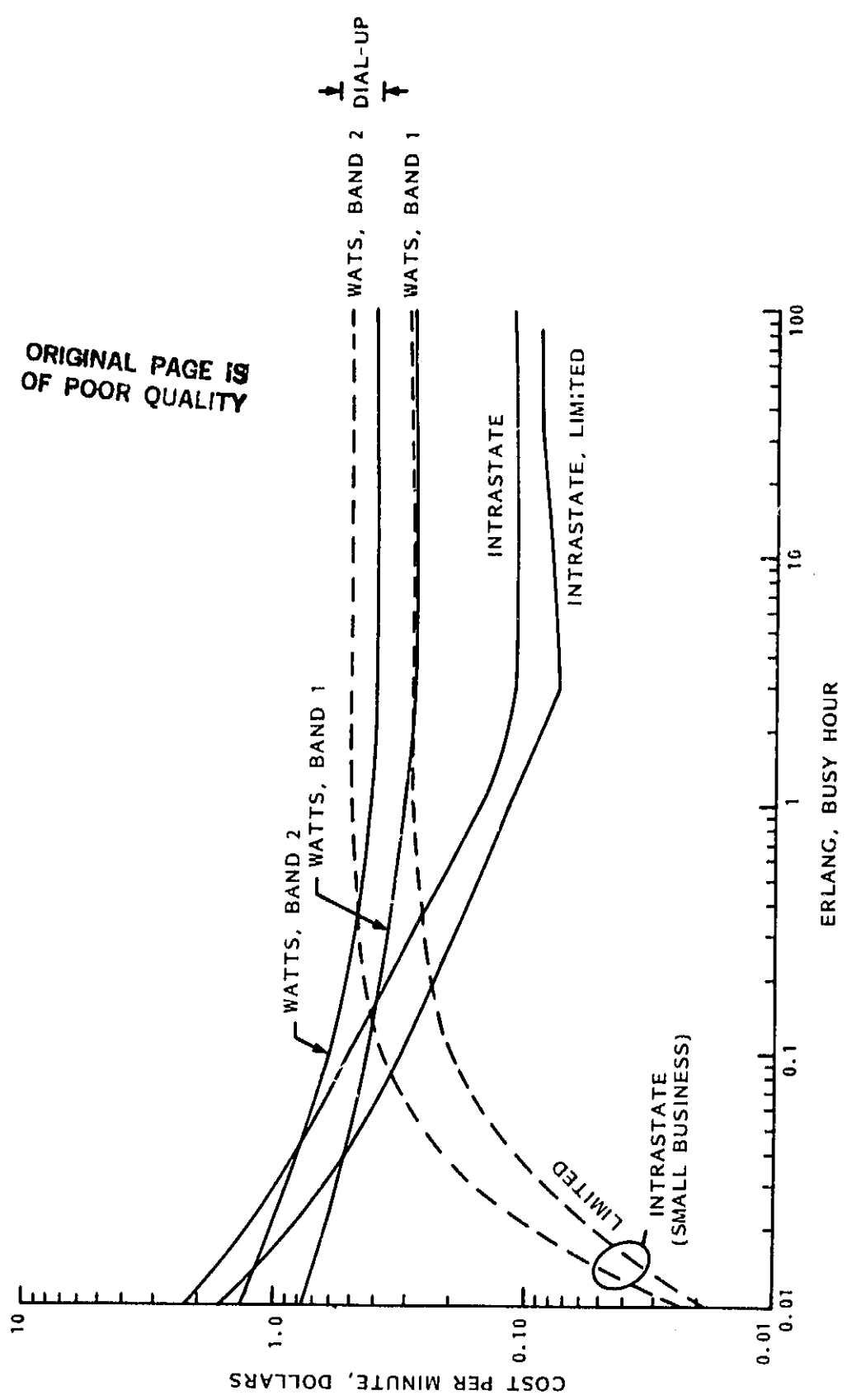

ORIGINAL PAGE IS
OF POOR QUALITY

Figure 4.5-2. Representative TELCO Service and Rates in Calls per Minute versus Busy Hour Capacity in Erlangs

Rates by AT&T (which are not the lowest), but, which are generally available are defined between cities. There are 400 "A" cities, however, recognizing the non-urban characteristic of the service, the rates between "A" and "B" cities were selected. These are plotted in Figure 4.5-3. Computing the traffic intensity for a 0.05 grade of service and assuming a peak to average factor of 2:1 the call costs for leased lines (no switching costs) can be estimated and tabulated in Table 4.5-6 and plotted in Figure 4.5-4.

Table 4.5-6. Call Charges for Leased Lines with Grade of Service = .05, at Various Distances (1982 AT&T Tariffs for A-B Cities)

| <u>Distance</u> | <u>20 Mile Rate</u> | <u>100 Mile Rate</u> | <u>500 Mile Rate</u> | <u>Erlangs (Peak)</u> |
|-----------------|---------------------|----------------------|----------------------|-----------------------|
| 1 - Trunk | 20.8¢/min. | 36.8¢/min. | 116¢/min. | .05 |
| 2 - Trunks | 5.5¢/min. | 9.7¢/min. | 30.5¢/min. | .38 |
| 3 - Trunks | 2.3¢/min. | 4.1¢/min. | 13.1¢/min. | 2.22 |
| 10 - Trunks | 1.7¢/min. | 3.0¢/min. | 9.3¢/min. | 6.22 |

Comparison of Figure 4.5-4 with dial-up charges in Figure 4.5-2 shows that for little traffic, say 0.05 erlangs, a leased line breaks even with WATS at around 300 miles. Beyond .1 erlang the leased line costs less even at short distances. The leased line is more expensive at very low traffic intensities (goes to infinite cost at zero erlangs).

4.5.4 RADIO RELAY*

Radio Relay systems can be used to connect a distant gateway to an operator. Typical costs for towers is given in Table 4.5-7,⁽¹⁾.

Table 4.5-7. Radio Relay Tower Costs

| | <u>Termination Ends</u> | <u>Relay Tower</u> |
|-----------------------|-------------------------|--------------------|
| Initial Cost | \$ 20,000 | \$ 20,000 |
| Shipping/Installation | 8,000 | 8,000 |
| FCC Permits | 9,000 | 9,000 |
| Trunk Costs | <u>5,000 x N</u> | <u>- -</u> |
| | \$ 37,000 + \$5,000N | \$ 37,000 |

ORIGINAL PAGE IS
OF POOR QUALITY

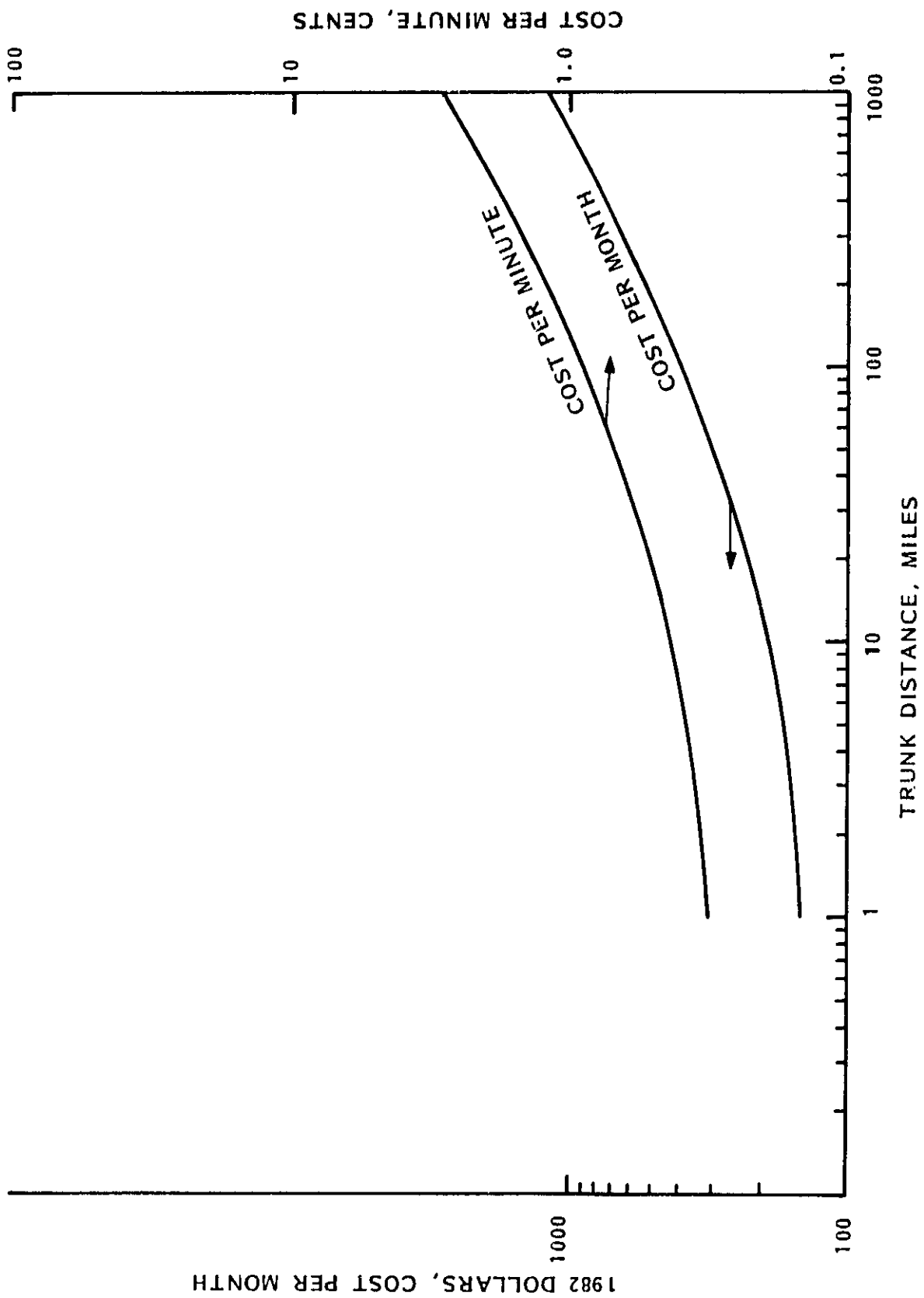

Figure 4.5-3. Lease AT&T Lines, A-B Cities, Cost per Month, Per Fully Utilized Minute with Two Termination Cost

1982 DOLLARS, COST PER MONTH

ORIGINAL PAGE IS
OF POOR QUALITY.

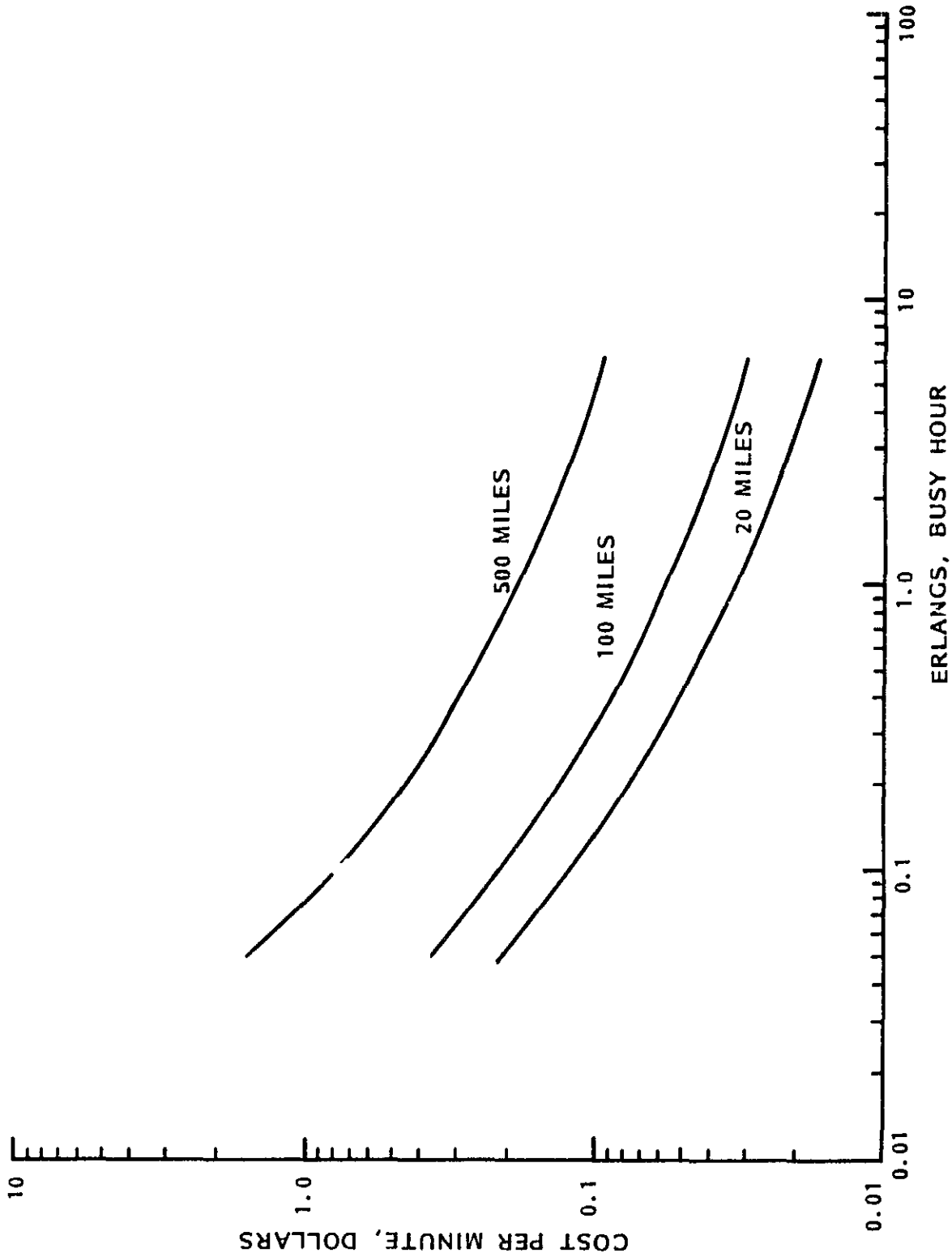

Figure 4.5-4. Leased AT&T Lines, A-B Cities, With Terminations;
Call Cost per Minute, Erlangs

The tower is procured for local use by the operator who must obtain the FCC permits and purchase the equipment. Capital recovery factor (CRF) is based on 10% for 10 years with 5% added for O&M for a total CRF = 0.21275.

Computations of cost versus number of trunks and distance covered by the radio relay are listed in Table 4.5-8 and plotted in Figure 4.5-5. Radio relay costs decrease dramatically with traffic intensity but also increase dramatically with distance. The zero erlang cost is infinite.

4.5.5 EARTH STATION GATEWAYS

In this case a gateway earth station is located on the operator's premises and connected directly either to the local telephone company (switch in the case of radio telephone, or to the dispatcher's control console or to a computer, etc. in the case of dispatch). A simplified block diagram is given in Figure 4.5-6 which depicts an SCPC (single channel per carrier) terminal for voice and wideband data. A common signalling channel (CSC) places each MODEM on the assigned frequency, (via the frequency synthesizer) according to the instructions received from the Network Operating Center, assumed to be a single centralized control center. The common signalling channel also may adjust the HPA power to conform to the number of simultaneously active channels and provide earth station control and alarms. The common signalling channel primary functions, however, are to adapt the satellite system to the signalling structure of the national telephone network.

For example, when a mobile address is being dialed and this is being routed to the gateway terminal, the gateway must store the dialed digits while simultaneously requesting a channel from the Network Operating Center. Presumably the request identifies the required satellite power and bandwidth. After channel allocation, the stored address is then relayed in-band to ring the mobile. The mobile emulates this sequence when it originates a call.

It is presumed in the following analyses that the gateway operates at UHF and S-band, using FDMA/DAMA (SCPC), and that it will be expected to serve in the interim as well as the more mature periods of the system operation. A "single thread" design is assumed since the communications can, in principle, be routed via a neighboring gateway and TELCO should the local gateway fail.

ORIGINAL PAGE IS
OF POOR QUALITY

Table 4.5-8. Computation of Radio Relay System Cost per Minute vs. Number of Trunks and vs. Distance

RADIO LINK RESULTS

| DISTANCE # TOWERS | 25 MI 2 | 50 3 | 75 4 | 100 5 | 200 6 |
|--------------------------------|--------------|--------------|--------------|--------------|---------------|
| <u>1 TRUNK</u> | | | | | |
| UNIT INVESTMENT | \$41,000 | \$78,000 | \$115,000 | \$152,000 | \$296,000 |
| CRF (INCL OEM) | 8,689 | 16,529 | 24,370 | 32,211 | 62,727 |
| LAND | <u>1,800</u> | <u>3,600</u> | <u>5,400</u> | <u>7,200</u> | <u>14,400</u> |
| TOTAL/YEAR | \$10,489 | \$20,129 | \$29,770 | \$39,411 | \$77,127 |
| (÷ BY 525600) | 2.0¢ | 4.0¢ | 6.0¢ | 7.8¢ | 15.4¢ |
| <u>COST/MIN (0.05 ERLANGS)</u> | | | | | |
| | 84¢ | 160¢ | 240¢ | 312¢ | 616¢ |
| <u>2 TRUNKS</u> | | | | | |
| UNIT INVESTMENT | \$47,000 | \$83,000 | \$120,000 | \$157,000 | \$301,000 |
| CRF | 9,960 | 17,589 | 25,430 | 33,270 | 63,787 |
| LAND | <u>1,800</u> | <u>3,600</u> | <u>5,400</u> | <u>7,200</u> | <u>14,400</u> |
| TOTAL/YEAR | \$11,760 | \$21,189 | \$30,830 | \$40,470 | \$75,187 |
| ÷ 525600 | 2.2¢ | 4.0¢ | 5.9¢ | 7.7¢ | 14.9¢ |
| <u>COST/MIN (0.38 ERLANGS)</u> | | | | | |
| | 11.6¢ | 21.2¢ | 30.9¢ | 40.5¢ | 78.2¢ |
| <u>10 TRUNKS</u> | | | | | |
| UNIT INVESTMENT | \$87,000 | \$124,000 | \$161,000 | \$198,000 | \$342,000 |
| CRF | 18,43¢ | 26,278 | 34,119 | 41,959 | 72,476 |
| LAND | <u>1,800</u> | <u>3,600</u> | <u>5,400</u> | <u>7,200</u> | <u>14,400</u> |
| TOTAL/YR. | \$20,236 | \$31,878 | \$39,519 | \$49,159 | \$86,876 |
| ÷ 525600 | 3.9¢ | 6.1¢ | 7.5¢ | 9.3¢ | 16.3¢ |
| <u>COST/MIN (6.22 ERLANGS)</u> | | | | | |
| | 1.2¢ | 2.0¢ | 2.4¢ | 3.0¢ | 5.3¢ |

ORIGINAL PAGE IS
OF POOR QUALITY

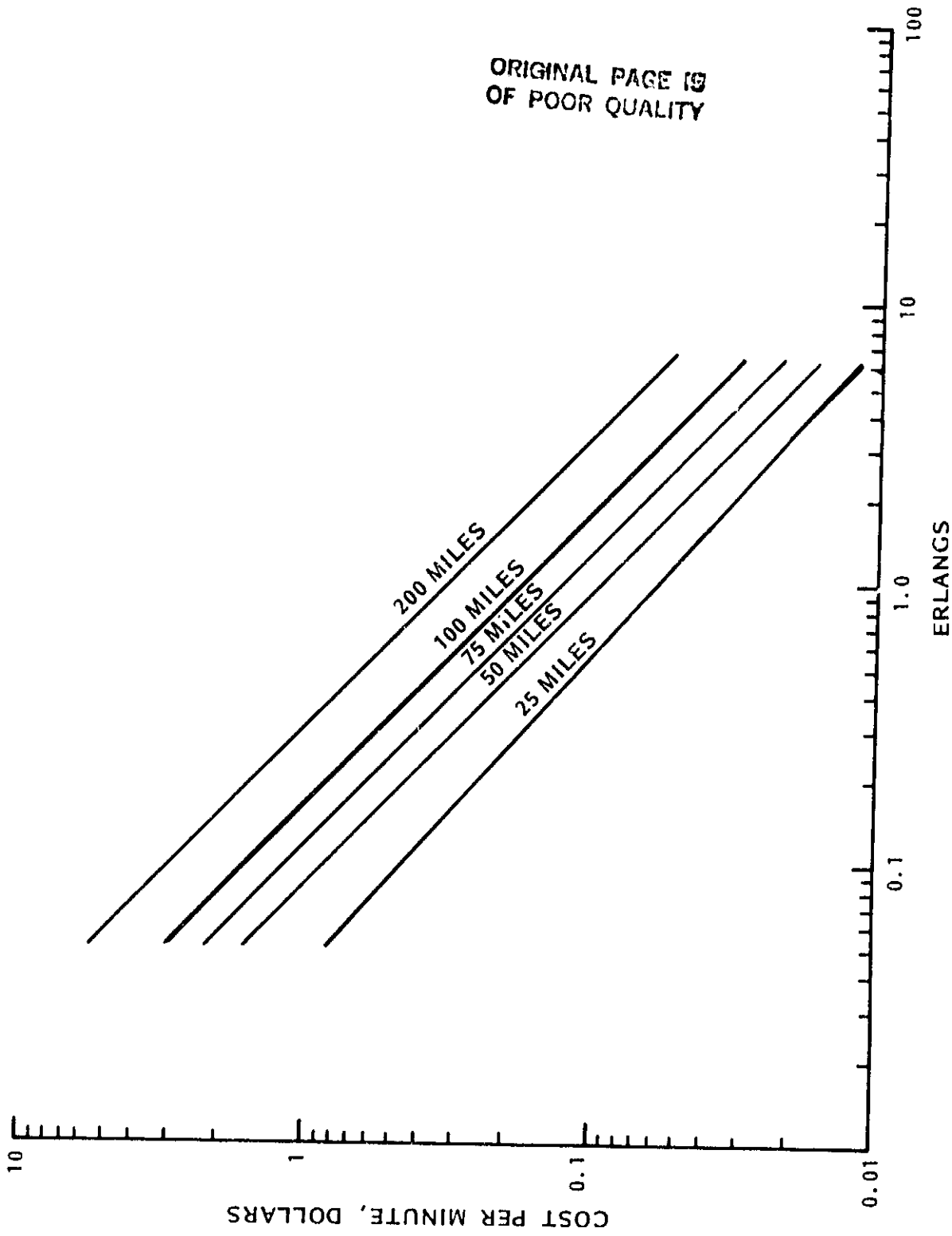

ORIGINAL PAGE IS
OF POOR QUALITY

Figure 4.5-5. Radio Relay Cost versus Traffic Intensity

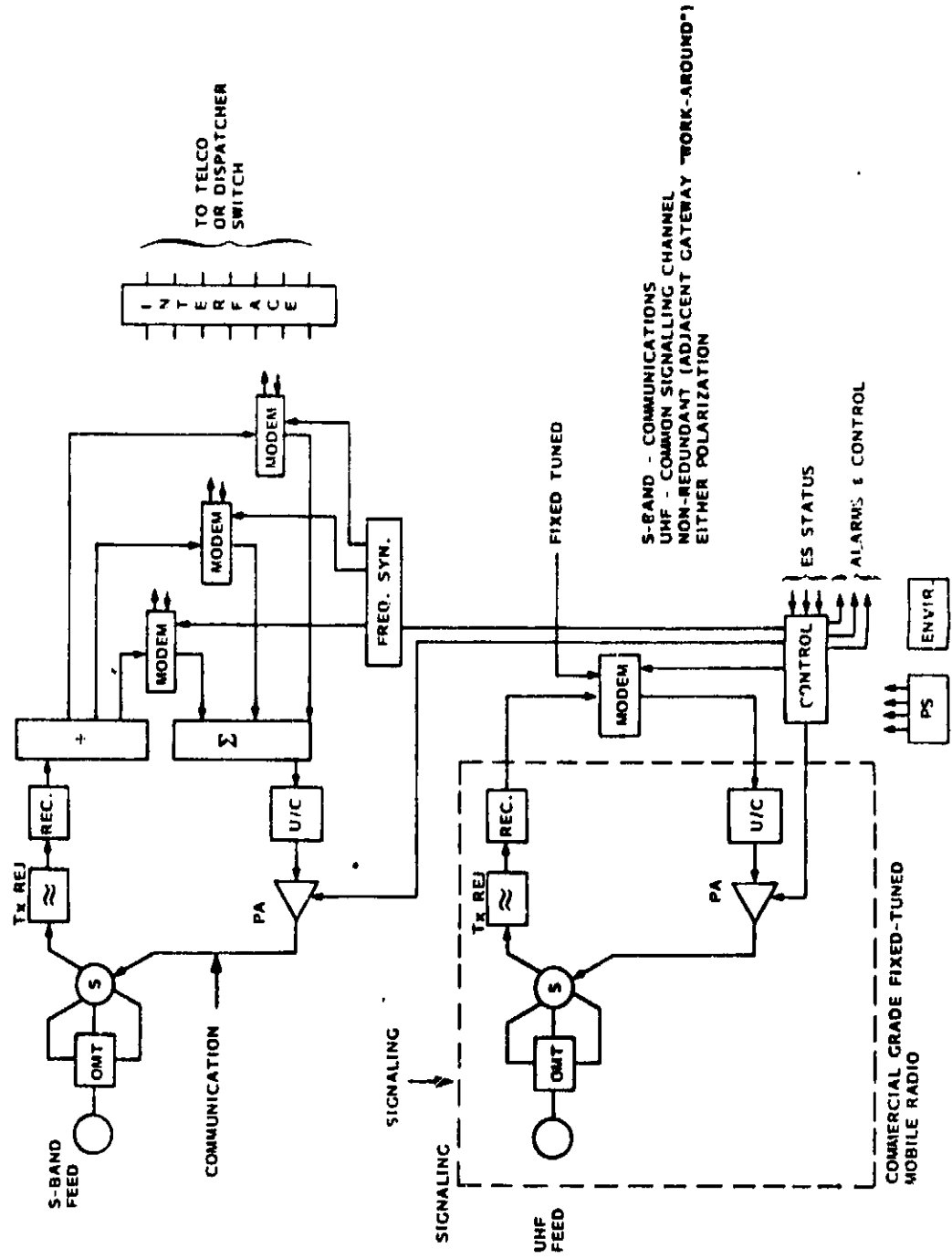

Figure 4.5-6. Simplified Block Diagram of Gateway Terminal

Since the gateway terminals may exist in large numbers, "learning" will be assumed to reduce production costs of gateways. Land, shelter and environmental control for the gateway is already available from the operator. Site preparation and installation are assumed not to be out-of-pocket costs. However, the final test ("commissioning") and frequency coordination and filing is provided by the satellite entity, or similar entity.

The antenna is a fixed 3 meter prime focus fed parabolic reflector and mount with a simple foam filled horn, foam filled coax transmission lines and OMT. The estimated small-quantity cost* in 1982 dollars is \$4,000, (approximately \$100 added for feed). The cost approximately satisfies the relationship; Cost (1982 dollars) = $167 + 154D^{1.47}$ where D = antenna diameter, feet.

While tradeoffs minimizing costs are possible, for example, minimize the total cost of antenna plus HPA, and minimizing total cost of satellite (S-band) HPA versus gateway antenna, such trade-offs are not believed to be of any great significance. First, the 3 meter antenna cost already is a small portion of the total gateway cost; further reducing its size has no significant economic benefit and increasing its size, say to 4 meters still will not result in its being a dominate cost, however, installation by the operator then becomes a problem. Secondly, it will be seen subsequently that the multiple beam satellite at S-Band, if used, with its higher antenna gain further reduces the gateway required performance, and therefore, reduces the significance of any trade-offs.

Table 4.5-9 lists the uplink/downlink gateway S-band link parameters for representative satellite systems having 1, 10 and 117 beams. Two modulations, FM and SSB are examined. A 6 dB HPA output back-off is assumed to apply to multiple carriers and the peak to average factor for companded SSB also is 6 dB. The resulting power requirements are displayed in Figure 4.5-7. HPA costs are only significant for large numbers of channels. The HPA costs are based on industry discussions on solid state amplifiers using methodology presented in the reference⁽²⁾. The HPA cost is, Cost (1982 dollars) = $2269P^{.35}$.

Table 4.5-9. S-Band Link, SCPC

| NUMBER OF BEAMS* | 1 | | 10 | | 117 | |
|----------------------------------|--------------|--------------|-----------|--------------|-----------|--------------|
| | 6° x 3° | 10 x 0.9 | 1.5° | 0.5 x 0.9 | 2.5 x 0.9 | UP DOWN |
| BEAMWIDTH | | | | | | |
| AVAILABLE BANDWIDTH, MHz | | | | | | |
| LINK | UP | DOWN | UP | DOWN | UP | DOWN |
| FREQUENCY, MHz | 2665 | 2620 | 2665 | 2620 | 2665 | 2620 |
| POWER, dBw | 0 | 0 | 0 | 0 | 0 | 0 |
| LOSSES, dB | -2 | -1 | -2 | -1 | -2 | -1 |
| BACK OFF, dB | 0/-5 | -6 | 0/-6 | -6 | 0/-6 | -6 |
| PEAK GAIN, dBi | 35.5 | 30 | - | 40.6 | - | 52.7 |
| EDGE OF COVERAGE GAIN, dBi | - | 27 (-3 dB) | - | 36.6 (-4 dB) | - | 48.7 (-4 dB) |
| EIRP, EFFECTIVE dBw | 33.5/27.5 | 20 | 33.5/27.5 | 29.6 | 33.5/27.5 | 41.7 |
| SPACE LOSS, dB | -192.1 | -191.9 | -192.1 | -191.9 | -192.1 | -191.9 |
| MISC., dB | -0.5 | -0.5 | -0.5 | -0.5 | -0.5 | -0.5 |
| ANT GAIN dBi | 27 | 35.3 (3M) | 36.6 | 35.3 | 48.7 | 35.3 |
| RECEIVED SIGNAL, dBw | -132.1/ | -137.1 | -122.5/ | -127.5 | -110.4/ | -118.4 |
| SYSTEM NOISE TEMP, dB > K | 26.4 (440°K) | 21.8 (150°K) | 21.8 | 21.8 | 21.8 | 21.8 |
| G/T dBi/K | +0.6 | 13.5 | - | - | - | - |
| C/T dBw/K | -158.5/ | -158.9 | -144.3/ | -149.3 | -132.2/ | -137.2 |
| | -164.5 | - | -150.3 | - | -138.2 | - |
| BW (FM) dB > 1Hz | - | 43 | 20KHz | - | - | - |
| BW (SSB) dB > 1Hz | - | 35.3 | 3.4KHz | - | - | - |
| CNR REQ. FM/SSB, dB | 30/33 | 15/18 | - | - | - | - |
| TOTAL CNR, FM/SSB, dB | 27.1/ | 26.7/ | 41.3/ | 36.3/ | 53.4/ | 48.4/ |
| | 28.8 | 34.4 | 43 | 44 | 55.1 | 56.1 |
| | | 15/44 | - | 125/ | - | 2188/ |
| # CHANNELS, FM/SSB, SIMULTANEOUS | - | 37/ | - | 400 | - | 6457 |
| # CHANNEL, FM/SSB, WITH VOX | - | 109 | - | 338/ | - | 5470/ |
| # CHANNELS REQ FM/SSB | - | 360/ | - | 1000 | - | 16141 |
| SAT POWER, FM/SSB, dBw | - | 2254 | - | 90/563 | - | 90/563 |
| | - | 10/ | - | - | - | - |
| | - | 13.1 | - | -5.7/ | - | -17.8/ |
| | - | - | - | -2.5 | - | -14.6 |
| AVERAGE ES POWER, FM/SSB, dBw | 2.9/ | - | -11.3/ | - | - | -23.4/ |
| SSB, dBw PER CHANNEL | 4.2 | - | -10 | - | - | -22.1 |

*PLUS OFFSHORE

ALLOCATED BANDWIDTH = 10 MHz
 DUAL POLARIZATION NOT CONSIDERED
 NUMBER OF BEAMS SAME AT UHF & S-BAND

ORIGINAL PAGE IS
 OF POOR QUALITY

ORIGINAL PAGE IS
OF POOR QUALITY

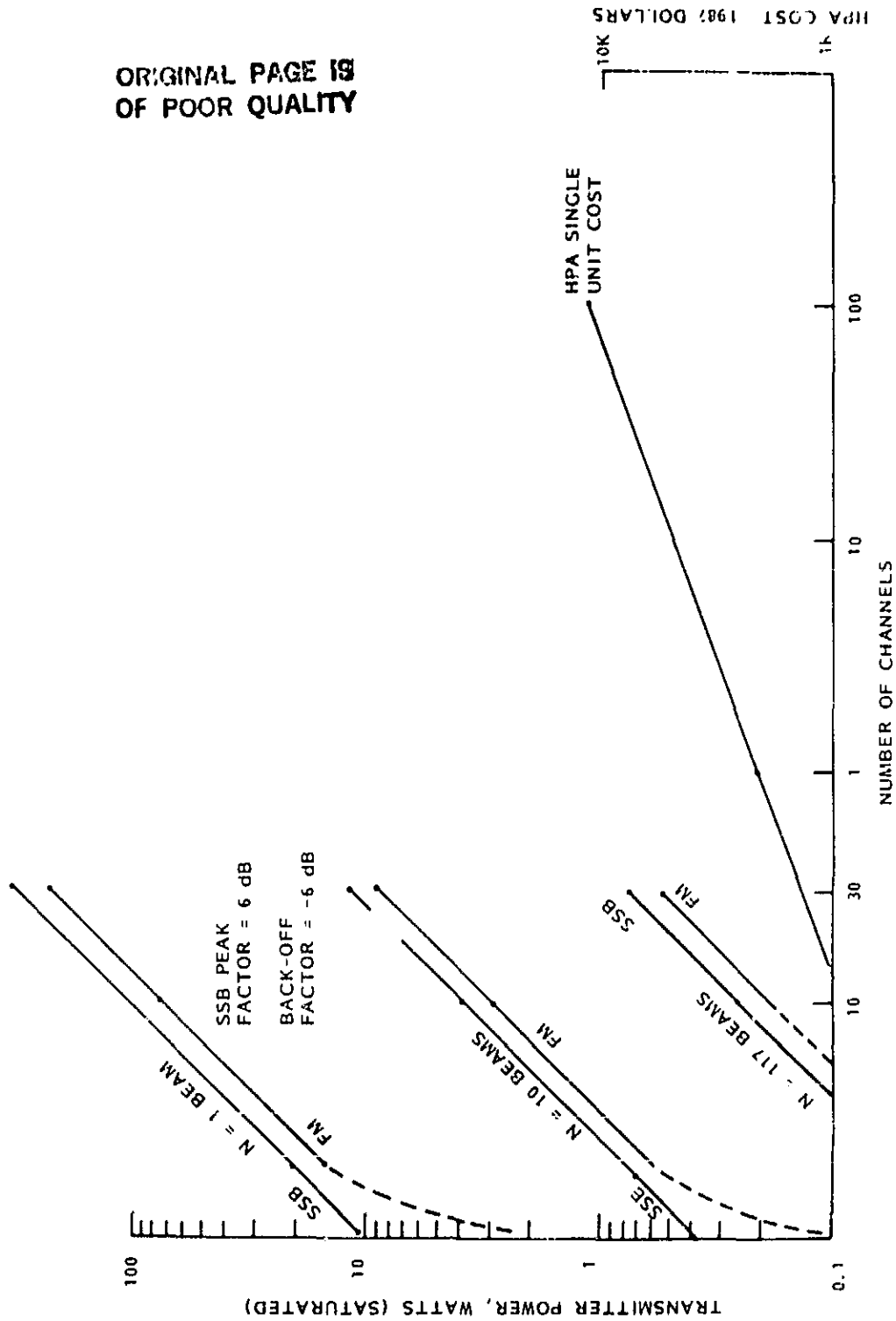

Figure 4.5-7. HPA Output Power vs Number of Simultaneous Channels for Both SSB and FM and for Different Numbers of Satellite Beams

Gateway costs can be computed using typical prices for existing equipment. A compilation for 1, 10 and 30 channels is given in Table 4.5-10. HPA costs must be added to the costs of Table 4.5-10 to get the total initial costs. The capital recovery factor is the same as for the radio case, e.g., based on 10% interest for 10 years with 5% added for O&M**. A learning factor can be added which is:

$$C = C_u L^{\ln N}$$

where C = Unit cost for N units

C_u = Single unit cost, $N=1$

L = Learning factor, averaged to .95 for an earth station

The learning curve factors are, therefore:

| | | |
|-------------|------|--------------------|
| $N = 100$ | .768 | Relative Unit Cost |
| $N = 1000$ | .648 | Relative Unit Cost |
| $N = 10000$ | .546 | Relative Unit Cost |

and are based on the assumptions of a mature technology, a standard, mass produced product and a competitive environment. The results are plotted in Figure 4.5-8.

Final comparisons are summarized in Figure 4.5-9 for the various technologies in terms of cost per minute versus traffic intensity in erlangs for the busy hour with a peak to average factor of 2:1. The TELCO costs for intensities greater than .4 erlangs are based on WATS, and those less than 0.4 erlangs based on dial-up. An interstate (total state, and limited) is also shown in dashes because, while cost effective, it may not apply (there may be no such rate structure or the route may be interstate). Otherwise, the cost for the leased lines (without switching), radio relay and gateway earth stations are added to Figure 4.5-9, as developed previously. An average cost (between SSB and FM) is used for the gateways, however, production quantity cost reductions ("learning") also are included.

The difference in gateway costs between FM and SSB are negligible, and the difference in cost between 1 beam and 117 beams is not significant - because the HPA costs are small compared to the total. Like leased lines and radio relay, the gateway costs are infinite at zero erlangs.

Table 4.5-10. Cost Summary for Gateway Terminals

A. ONE SATELLITE BEAM

| | 1 | 2 | 10 |
|---|-----------|-----------|-----------|
| NUMBER OF TRUNKS | | | |
| ERLANGS, BUSY HOUR | 0.05 | 0.38 | 6.22 |
| EARTH STATION BASE COST, DOLLARS* | 36,000 | 41,000 | 81,000 |
| HPA (FM) COST, DOLLARS | 2,800 | 3,900 | 10,330 |
| HPA (SSB) COST, DOLLARS | 5,200 | 6,600 | 11,570 |
| COST, FULL TIME, FM/SSB, CENTS PER MINUTE | 1.6/1.6 | 1.80/1.84 | 3.53/3.58 |
| COST, FM/SSB, CENTS PER MINUTE | 60.5/64.2 | 9.5/9.7 | 1.2/1.2 |

B. TEN SATELLITE BEAMS

| | 1 | 2 | 10 |
|---|---------|-----------|---------|
| NUMBER OF TRUNKS | | | |
| ERLANGS, BUSY HOUR | 0.05 | 0.38 | 6.22 |
| EARTH STATION BASE COST, DOLLARS* | 36,000 | 41,000 | 81,000 |
| HPA (FM) COST, DOLLARS | 1,000 | 2,300 | 3,300 |
| HPA (SSB) COST, DOLLARS | 1,600 | 2,300 | 3,700 |
| COST, FULL TIME, FM/SSB, CENTS PER MINUTE | 1.5/1.5 | 1.69/1.70 | 3.3/3.4 |
| COST, FM/SSB, CENTS PER MINUTE | 59/60 | 8.9/9.0 | 1.1/1.1 |

C. ONE HUNDRED SEVENTEEN BEAMS

| | 1 | 2 | 10 |
|---|---------|-----------|---------|
| NUMBER OF TRUNKS | | | |
| ERLANG, BUSY HOUR | 0.05 | 0.38 | 6.22 |
| EARTH STATION BASE COST, DOLLARS* | 36,000 | 41,000 | 81,000 |
| HPA (FM) COST, DOLLARS | ~0 | ~0 | 1,300 |
| HPA (SSB) COST, DOLLARS | ~0 | ~0 | 1,400 |
| COST, FULL TIME, FM/SSB, CENTS PER MINUTE | 1.5/1.5 | 1.65/1.65 | 3.3/3.3 |
| COST, FM/SSB, CENTS PER MINUTE | 60/60 | 8.7/8.7 | 1.1/1.1 |

ASSUMPTIONS

| | | |
|----------------|---|---------------------|
| INTEREST = 10% | } | 20% |
| ROI = 10% | | |
| CRF = 0.16275 | } | CRF TOTAL = 0.21275 |
| O&M = 5% | | |

*INCLUDES UHF "MOBILE" EQUIPMENT FOR LINK TO NETWORK OPERATING CENTER

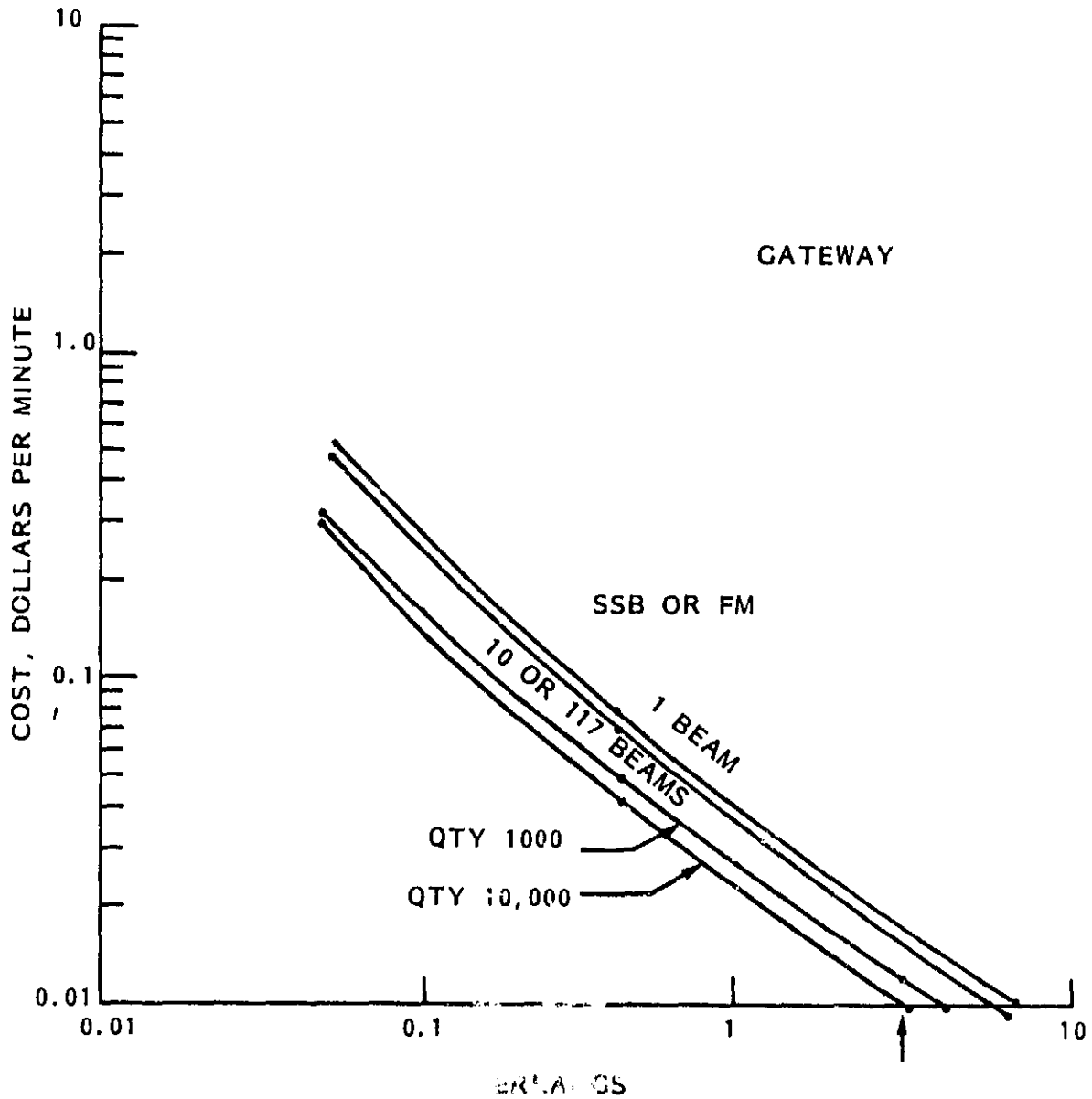
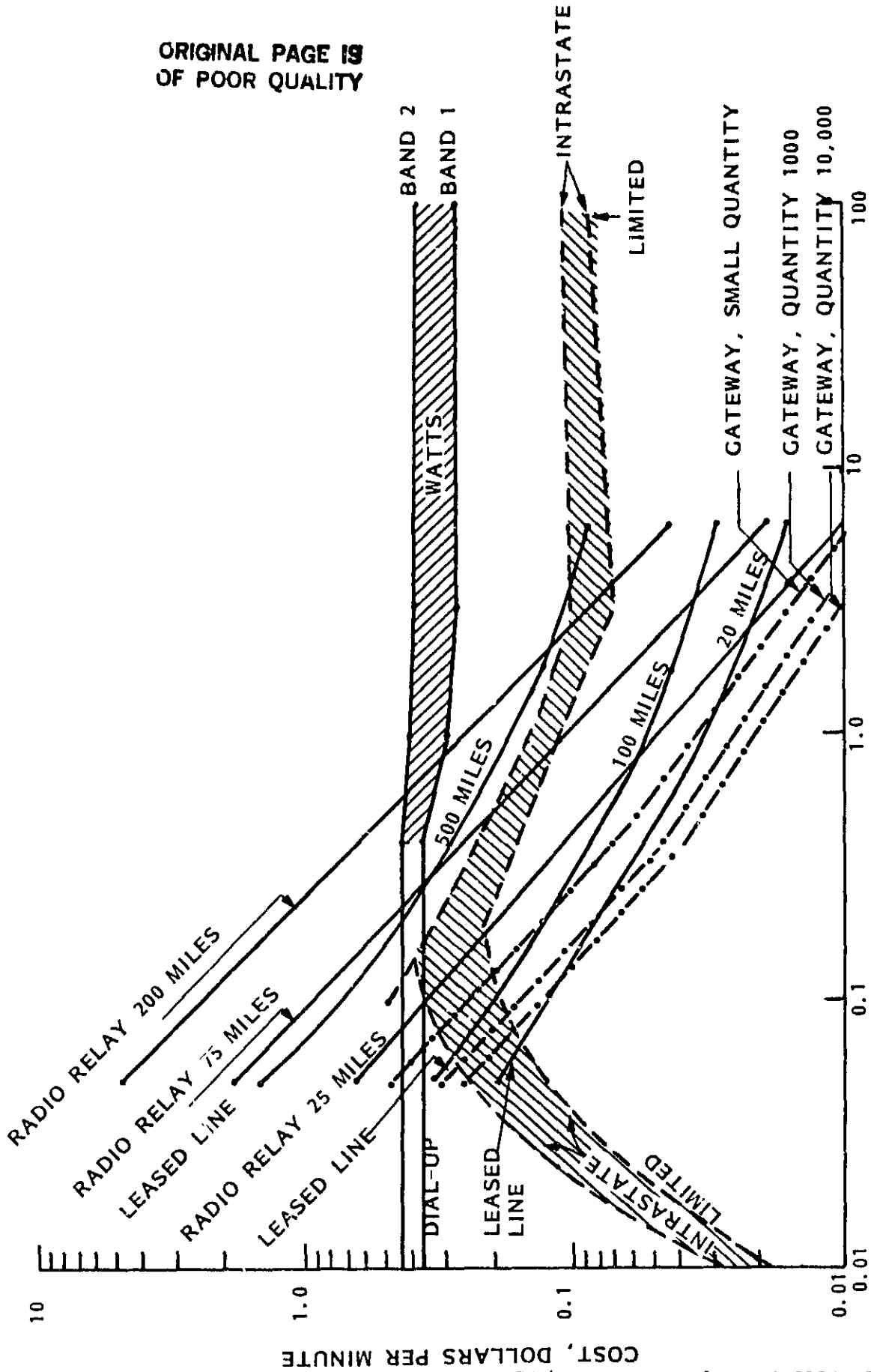

Figure 4.5-8. Cost per Minute vs. Areas for Gateway Terminals

ORIGINAL PAGE IS
OF POOR QUALITY



ERLANGS, BUSY HOUR

Figure 4.5-9. Summary of Comparisons with Gateway

COST, DOLLARS PER MINUTE

4-153

ORIGINAL PAGE IS
OF POOR QUALITY

WPC-0113M-15M

At very low intensities, say below about 0.03 erlangs, the Telephone dial-up facilities are cost effective - about 38¢ to 47¢ per minute. If available, the small business interstate is even less costly. Above about 0.05 erlangs the gateway terminals are the preferred solution. Leased lines less than 100 miles are comparable in cost, however, radio relay, even at 25 miles (2 hops) is more expensive. Neither WATS nor the special interstate large business service (if available) is cost effective compared to the gateway.

This is a fortunate result because it means that virtually every operator will have a gateway terminal, and every mobile call will have only a local TELCO charge. Systems will likely evolve in areas justifying the gateway investment. For radio-telephone, this will correspond to an area containing the mobile's home base, (the system charges, of course, are distance-invariant). For trunking applications, location of the gateway at "headquarters" is axiomatic. Consequently, the gateway network is expected to be very large, caused principally by the expensive TELCO charges, even for short distances. In addition, great system flexibility is achieved if alternate routing can be accomplished via another gateway and the TELCO. Data facilities also are favored because the gateway can be located at the computational facilities, eliminating resultant noise and bandwidth impairments.

Above 1 erlang this gateway cost (or charge) is 2 to 2.5¢ per minute, considerably less than the satellite charge.

Figure 4.5-9 depicts monthly gateway charges for typical radio-telephone and trunking users showing that the gateway costs (note that the satellite portion of the gateway link are included with the space segment) are not significant if the gateway traffic is 1 erlang or more; one erlang corresponds approximately to 33 radio telephone subscribers or 100 trunking subscribers.

It is believed that similar results will be obtained for Ku Band and that the cost of a Ku Band gateway will exceed that of an S-Band gateway by no more than 20%. If the Gateway is provided by the satellite operator, a higher CRF, to allow an investment return, is required.

REFERENCES

- (1) Customer Premise Service Study, NAS-3-22890, NASA Lewis Research Center, July 1982.
- (2) Communications Technology Assessment Study, NAS3-20364, ibid.

ORIGINAL PAGE IS
OF POOR QUALITY

4.6 MOBILE RADIOS

4.6 MOBILE RADIOS

4.6.1 TRANSCEIVERS

4.6.1.1 Introduction

The purpose of this section is to define the mobile transceivers used in the LMSS. Three generic types are considered. One is a cellular compatible transceiver capable of operating with either the cellular system or the satellite system; its primary functions are to provide voice communications (or dial-up wideband data) to extra-cellular roamers and paging service. This transceiver uses FM. A second transceiver, based on amplitude compandored SSB is a "stand-alone" voice unit for radio telephone. A third transceiver, also based on amplitude compandored SSB is a "stand-alone" voice unit for private dispatch networks. Both these transceivers are controlled by a satellite network common signalling channel and satellite channels are assigned on demand. The fourth transceiver is intended for interactive data exchange, telemetry (status), control, and position location service. This transceiver can operate with either satellite but, on fixed channels. The transmitter, energized only when required, transmits status information back to the NOC when interrogated by the NOC or spontaneously in the case of an alarm. Communications to the transceiver are from the NOC only. In addition, a transceiver turn-around function is provided for position fixing, which requires communications with both satellites. The four receiver types are generally defined for purposes of the Study. In actual practice, these may be combined. For example, the interactive data transceiver can be added to any of the other transceivers to provide a composite capability, or the cellular compatible transceiver might be further modified to make use of CSSB for satellite use.

4.6.1.2 Cellular - Compatible Transceiver

The AT&T AMPS vehicle transceiver (1) and frequency plan as depicted in Figure 4.6-1 is an example of a cellular radio designed for use in urban areas. It consists of a single receive and single transmit channel whose frequency (one of 666) is controlled by a logic and control unit. The transceivers are designed to operate in the cellular environment which is characterized by severe fading due to multipath, large dynamic changes in signal and interference levels, and by extensive requirements for signalling in order to accomplish hand-off in geographically small cells.

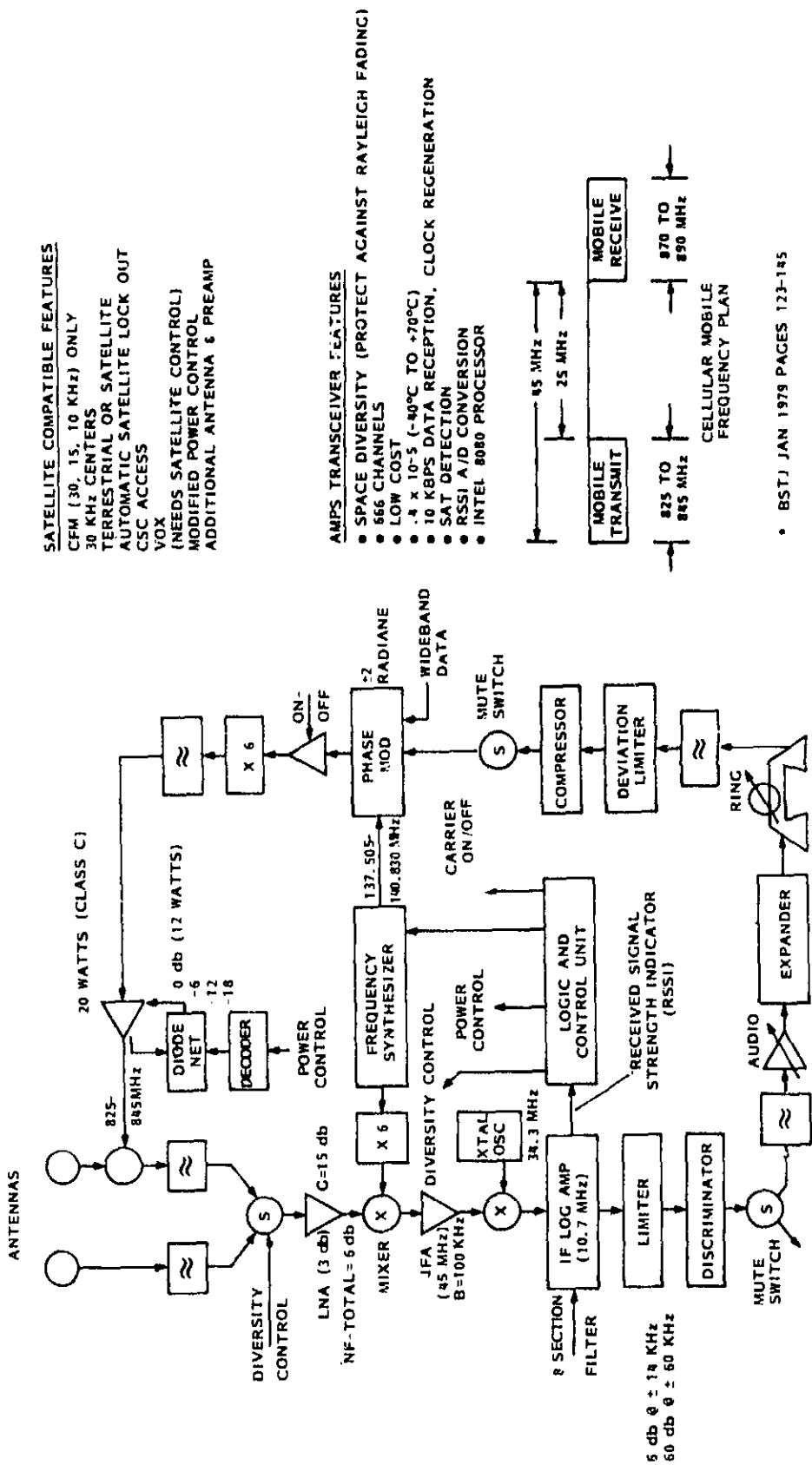

SATELLITE COMPATIBLE FEATURES

- CFM (30, 15, 10 KHz) ONLY
- 30 KHz CENTERS
- TERRESTRIAL OR SATELLITE
- AUTOMATIC SATELLITE LOCK OUT
- CSC ACCESS
- VOX
- (NEEDS SATELLITE CONTROL)
- MODIFIED POWER CONTROL
- ADDITIONAL ANTENNA & PREAMP

AMPS TRANSCIEVER FEATURES

- SPACE DIVERSITY (PROTECT AGAINST RAYLEIGH FADING)
- 566 CHANNELS
- LOW COST
- 4 x 10⁻⁵ (-40°C TO +70°C)
- 10 KBPS DATA RECEPTION, CLOCK REGENERATION
- SAT DETECTION
- RSSI A/D CONVERSION
- INTEL 8080 PROCESSOR

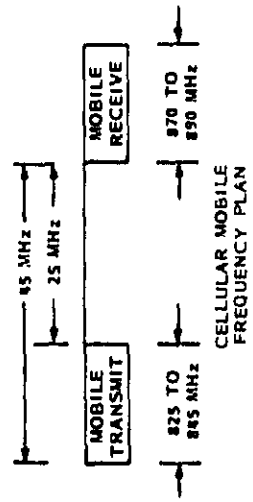

• BSTJ JAN 1979 PAGES 123-125

Figure 4.6-1. AMPS Vehicle Transceiver (a) and RF Compatible Unit (b)

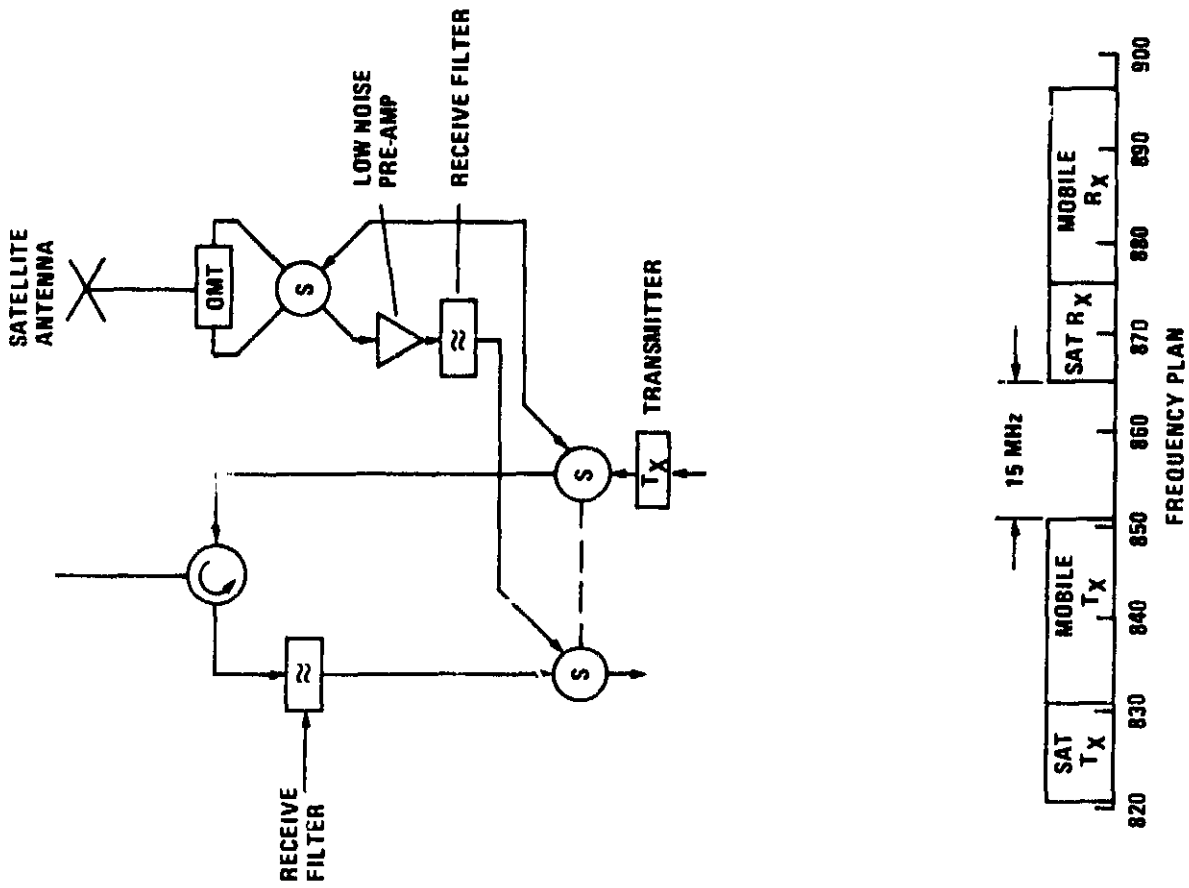

Figure 4.6-1. AMPS Vehicle Transceiver (a) and Compatible RF Unit (b) (Cont.)

Two receive antennas are used: the one with the strongest signal is selected (the second antenna has since been omitted). The receiver overall noise figure is 6 dB and a 10.7 MHz IF logarithmic amplifier is used to control the signal level and provide a "received signal strength indicator" (RSSI), which indication is provided to the Mobile Telephone Switching Office. Companded FM is used with a receiver 6 dB bandwidth of ± 14 KHz. The class "C" power amplifier is controlled to provide either 12, 3, .75, or .18 watts to the antenna in order to control co-channel and adjacent channel interference. Receive and transmit channel "muting" and transmitter on/off controls also are provided.

The frequency synthesizer is depicted in Figure 4.6-2. The phase comparator compares the 5 KHz frequency divided down from the 43.92 MHz LO with the output frequency f_0 divided by N. N is an integer controlled by the logic and control unit which determines the channel frequency. The frequency is multiplied by six to obtain the transmit frequency and also multiplied by six to mix with the received signal to obtain a fixed offset of 45 MHz (the receive and transmit channels are separated by 45 MHz in the AMPS plan). FSK data (10KBPS) also can be provided instead of voice. The logic and control unit contains a microprocessor.

A minimum modification of this concept adds a circularly polarized antenna optimized for satellite use (a third antenna), a low noise pre-amp and some adjustment to provide the correct power amplifier level for satellite use. VOX operation of the PA also is required to make best use of the satellite power.

The frequency synthesizer can provide channels on 30 KHz centers encompassing both the proposed satellite and cellular frequency bands. In the absence of terrestrial signals (or on terrestrial system command) the transceiver can tune to the satellite common signalling channel, which emulates the format and responses of the terrestrial MTSO (mobile telephone switching office). When idle, the receiver also should continue to search for the terrestrial system control carriers so that operation automatically reverts back to cellular terrestrial operation. Such operation imposes a minimum modification to the transceiver, but, is not particularly advantageous to LMSS. A further attractive modification is the adoption of 15 KHz CFM to make better use of the spectrum-starved satellite service (conversion to SSB for example,

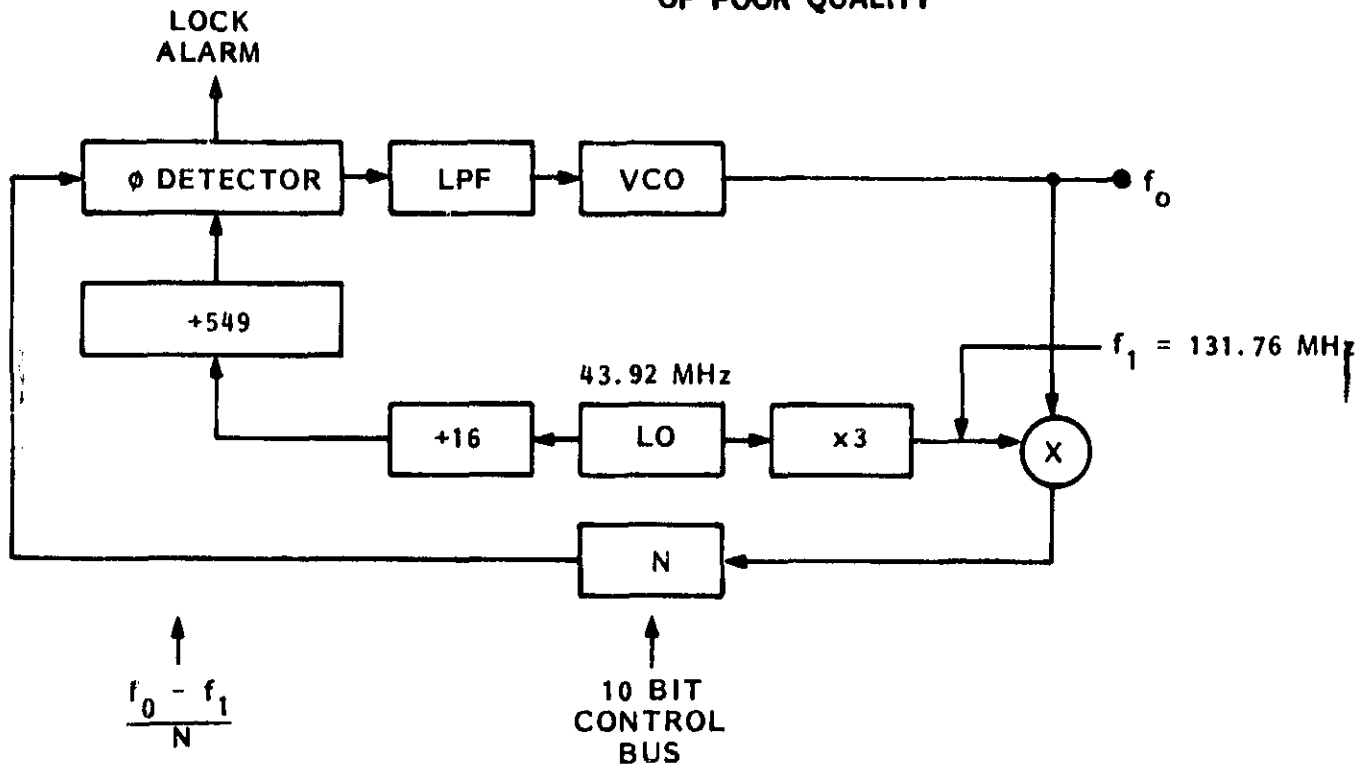

Figure 4.6-2. Typical Frequency Synthesizer for Cellular Radio

requires a new HPA and MODEMS). The compandor should still enable a high quality signal when the FM carrier is at or above threshold. However, the frequency synthesizer, operating on 30 KHz centers leaves the spectrum half empty. Other services can occupy these 15 KHz spaces. Alternatively, the master oscillator in the transceiver can be "pulled" (883 Hz) "half" a spacing, on command, to fill the remaining 15 KHz channel slots, (or a second oscillator, offset by 833 Hz can be switched in).

Also desirable is conversion to a power efficient signalling channel modulation such as PSK. The satellite operator also may prefer a single unified common signalling channel for the satellite network. Finally, the continuous presence of a common signalling channel may be needed for AGC and for antenna steering. These changes are substantial in number, but are not believed to have substantial cost implications. However, a radio-telephone (cellular) subscriber will bear the added cost of these modifications and pay his usage fee for the satellite service if these costs are moderate and if he needs them. Clearly, most subscribers will not, at least not in the early years of service.

The extent of the modifications and the costs thereof, will depend on the operator and subscriber perceived value of the satellite service. Eventually the satellite-compatible production transceivers will not be substantially different in cost than the basic cellular-only model.

4.6.1.3 Dispatch and Radio Telephone (Stand-Alone) Transceiver

This transceiver is intended only for satellite use (hence stand-alone) and is optimized for that use only. Particularly desirable features are the use of compressed single side band (CSSB) for voice, a continuous available common signalling channel, high G/T, and good polarization purity. Operation on either polarization is useful in case of satellite failure or for position location service. The frequency synthesizer operates the transceiver on 4 KHz centers. Consequently, channels are assigned for either 30 KHz (cellular compatible) or 4 KHz spacings using different parts of the spectrum, all under the control of the NUC. This permits dynamic sharing of the total services by the two networks.

An example transceiver is depicted in Figure 4.6-3. It is similar to the AMPS transceiver description except for the noted changes. The full time common signalling channel also provides AGC and antenna steering (step-track) if needed. The telephone is 4-wire so echo cancellers are not needed. The single beam satellite requires only one common signalling channel (actually one CSC is used between the mobile and the NUC and another CSC between the NUC and Gateway). However, multibeam satellites using 4:1 segmentation may require additional common signalling channels. The transceiver will have to measure which of these is the strongest, use it, and so inform the NUC. Note that the CSSB system has provisions for (limited) in-band signalling.

The basic transceiver configuration, and component parts are similar to the terrestrial cellular system and thus should be of similar cost. The more sophisticated satellite antenna is not expected to be a significant cost factor, even if steered. Less power is required, and fewer channels might be provided (simplifying, the frequency synthesizer) to reduce costs below that of the cellular transceiver.

ORIGINAL PAGE IS
OF POOR QUALITY

- CSSB FOR VOICE, PSK FOR DATA
- FULL TIME COMMON SIGNALLING CHANNEL
- EITHER POLARIZATION
- 1 1 OR 4 1 FREQUENCY SEGMENTATION
- VOX
- WIRE TELEPHONE

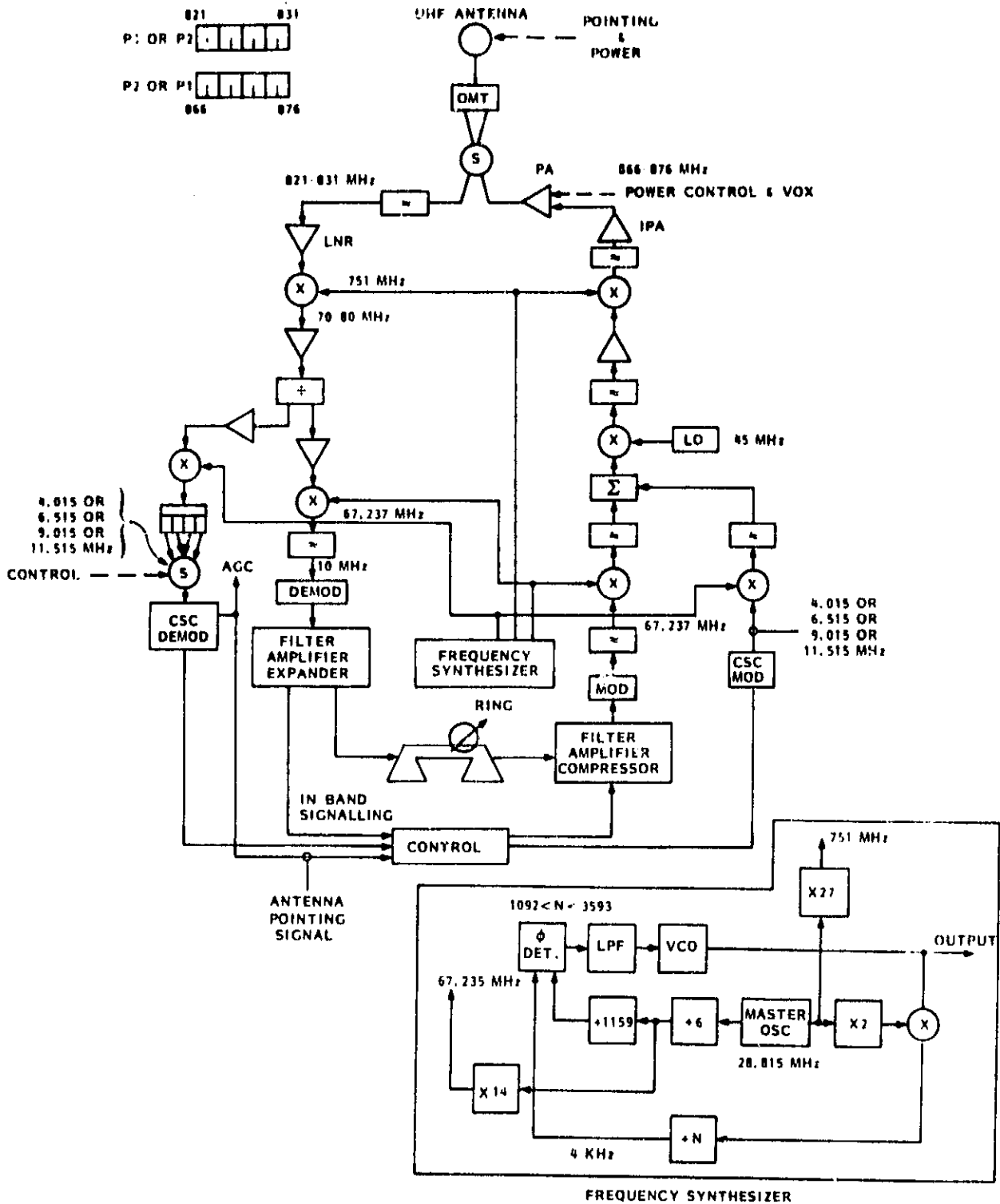

Figure 4.6-3. Radio Telephone or Dispatch (Stand-Alone) Transceiver

LO stability will be a problem for the narrow band CSSB service operating on 4 KHz centers. A typical low (consumer) cost LO will have a stability of 10^6 over a temperature range of -40°F to 140°F , which is not acceptable for CSSR. Improvement of stability to 10^7 while acceptable for CSSR requires an oven and perhaps labor intensive test procedures.

An alternative is to have the transceiver lock to the common signalling channel carrier via a transceiver locked loop, and use the retrieved carrier as a standard frequency for the synthesizer.

Once locked, all frequencies required for the internal operation of the transceiver, including the frequency synthesizer are derived from the "locked" VCO. The frequency error is zero, except for doppler. This requires a continuously available common signalling channel which is believed to be an advantage in the satellite system for other reasons (such as for positive network control). When energized, the receiver searches for the strongest of the four common signalling channels (one per beam), and locks to it. It must periodically repeat the process (perhaps when the transceiver is on-hook) in order to detect a cell transition. Several examples are given to illustrate the idea, however a detailed design and analysis, beyond the scope of this study, is needed to derive an optimum configuration and achieve a minimum cost. Principle design ground rules are:

1. The common signalling channel must be a multiple of the VCO to be locked.
2. The VCO frequency must be low enough so that a common signalling channel is available in each of the four frequency segmentations - somewhere near the middle of the respective bands.
3. The phase detector of the frequency synthesizer should operate with 4 KHz inputs (for lock).
4. The frequency synthesizer reference should be a multiple of the VCO.
5. If uplink/downlink coherence is needed then the synthesizer reference should be 45 MHz or a submultiple thereof.

An example of such an arrangement is shown in Figure 4.6-4. The phase locked receiver consists of the VCO, phase detector, and multipliers "M" and "N" with associated mixers, filters and amplifiers. In the example the VCO frequency

ORIGINAL PAGE IS
OF POOR QUALITY

is 4.0 KHz, "M" is a fixed multiplier, and "N" has four values, indicated in Table 4.6-1, for the four possible common signalling channel frequencies, which are controlled by the "Control".

Once locked, the VCO provides all of the reference frequencies, including $Q \times 4 \text{ KHz} = 22.5 \text{ MHz}$ for the frequency synthesizer reference. Note that changing "N" does not affect the communication paths. While not illustrated in Figure 4.6-4, Table 4.6-1B indicates a frequency and multiplication arrangement based on a 0.1 MHz VCO which results in simpler multiplication ratios. The VCO cannot be much higher (perhaps 1.0 MHz) otherwise common signalling channels in each of the four frequency segments cannot be achieved. The added components are a few, inexpensive low frequency circuits consisting principally of the phase locked loop, the "N" multiplier and the related low frequency receiver component. The remaining components are needed in any event.

Table 4.6-1. Frequencies and Multipliers For Frequency Tracking

A) PLAN BASED ON 4 KHz VCO (SEE FIGURE 4.6-3)

COMMON SIGNALLING CHANNEL FREQUENCIES

| MOBILE RECEIVE MHz | MOBILE TRANSMIT MHz | M | N | P, Q |
|--------------------|---------------------|--------|-------|------|
| 867.248 | 822.248 | 187750 | 29061 | 5625 |
| 869.748 | 824.748 | 187750 | 29868 | 5625 |
| 872.248 | 827.248 | 187750 | 30311 | 5625 |
| 874.748 | 829.748 | 187750 | 30936 | 5625 |

B) ALTERNATIVE PLAN BASED ON 0.1 MHz VCO

COMMON SIGNALLING CHANNEL FREQUENCIES

| MOBILE RECEIVE MHz | MOBILE TRANSMIT MHz | M | N | P, Q |
|--------------------|---------------------|--------------------|------------------------|-----------------|
| 867.1 | 822.1 | 7510 (5 x 2 x 751) | 1160 (5 x 8 x 29) | 225 (5 x 5 x 9) |
| 869.6 | 824.6 | 7510 (5 x 2 x 751) | 1185 (5 x 3 x 79) | 225 (5 x 5 x 9) |
| 872.1 | 827.1 | 7510 (5 x 2 x 751) | 1210 (5 x 2 x 11 x 11) | 225 (5 x 5 x 9) |
| 874.6 | 829.6 | 7510 (5 x 2 x 751) | 1235 (5 x 13 x 19) | 225 (5 x 5 x 9) |

ORIGINAL PAGE IS OF POOR QUALITY

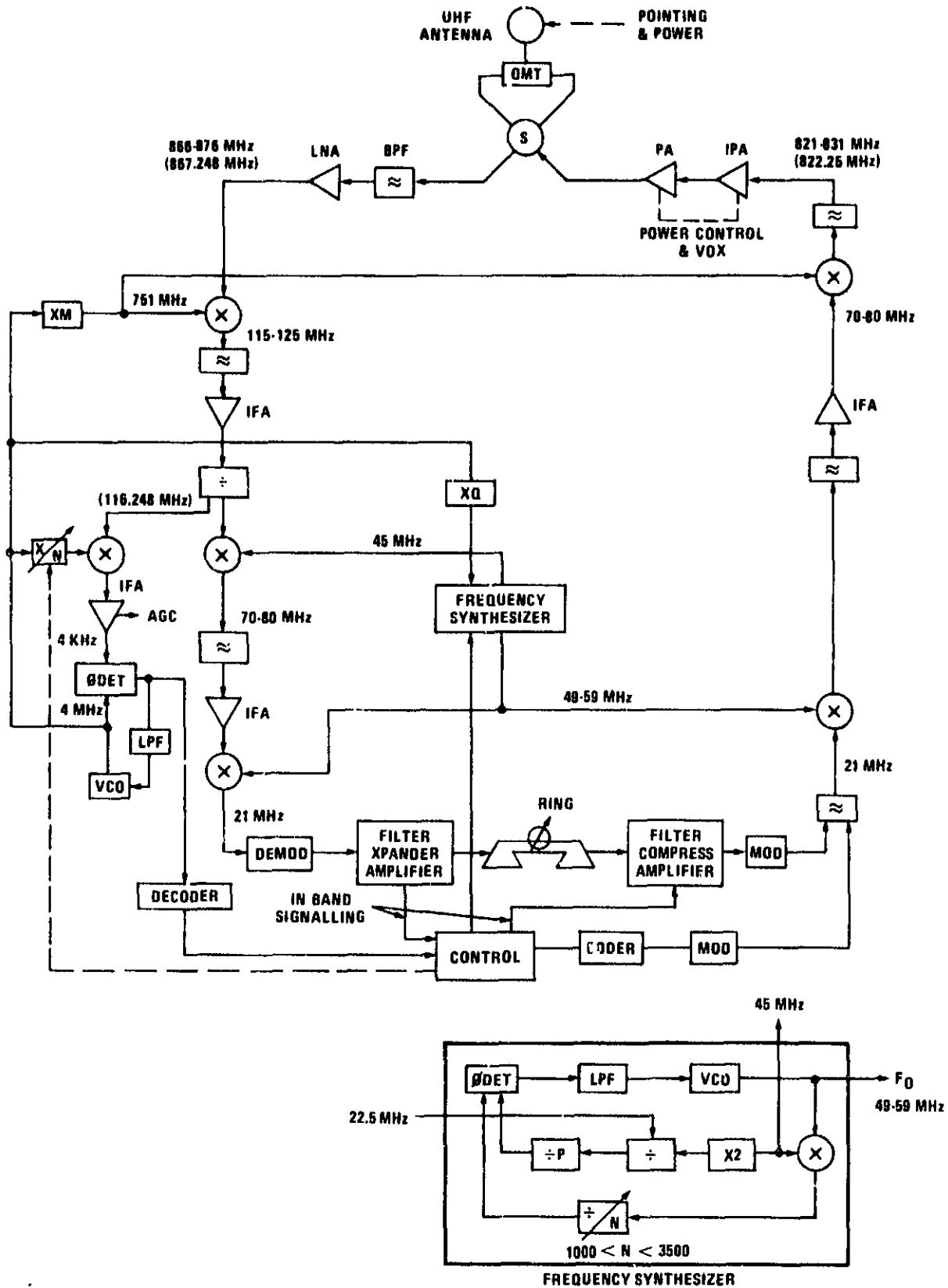

Figure 4.6-4. Example Stand-Alone Dispatch or Radio Telephone Transceiver (with frequency lock).

4.6.1.4 Interactive Data/Telemetry/Position Location Transceiver

This system function is similar to that described in Reference (2) and is depicted in Figure 4.6-5. For ranging through either satellite the NOC transmits a precursor stream of alternate 1's and 0's followed by a transceiver address. Each transceiver phase locks to this signal, taking about 26 milliseconds (256 cycles) for settling. When correct station address is received, the local locked oscillator is used to count a fixed delay (which is digitized and added to the data) at which time the transceiver address and data is clocked out (using the locked oscillator). Receipt of the signal back at the NOC enables measurement of the slant range from the satellite to the transceiver. A similar sequence of events using the second satellite but on the orthogonal polarization enables the NOC to compute a position fix, and relay this information to the proper gateway (operator). The transceiver of course is commanded to operate on the second polarization and returns to the original polarization after a time-out. A ring around circuit in the transceiver enables calibration of the transceiver delay which also is digitized and added to the data. In typical equipment, the transceiver delay can be of the order of 100 microseconds and can vary 2 microseconds with temperature (which is too large to be ignored).

The ranging resolution achieved in Reference (2) is tens of meters. Ranging transceivers at known locations provide for overall calibration.

This basic unit also can be used for interactive data exchange between the mobile and the NOC. The communication is expected to be occasional so that the average throughput per mobile is very low. The mobile telemetry data information can relate to the equipment status, for example, of a truck trailer, e.g., whether it is hooked-up, to whom, secure, properly maintained, within temperature limits, etc. Or the message may consist of standard routing information punched in by the truck driver.

Communications from the NOC might consist of routine routing instructions, weather alerts, road conditions, etc. The NOC serves as the focus for such traffic, compares and formats the outgoing messages, processes the incoming messages and provides processed data to the customers (dispatchers, etc.). This arrangement, with the NOC always at one end of the link, enforces network discipline and maintains channel efficiency. Outgoing traffic to mobiles, including interrogation for response and position fixing is TDM.

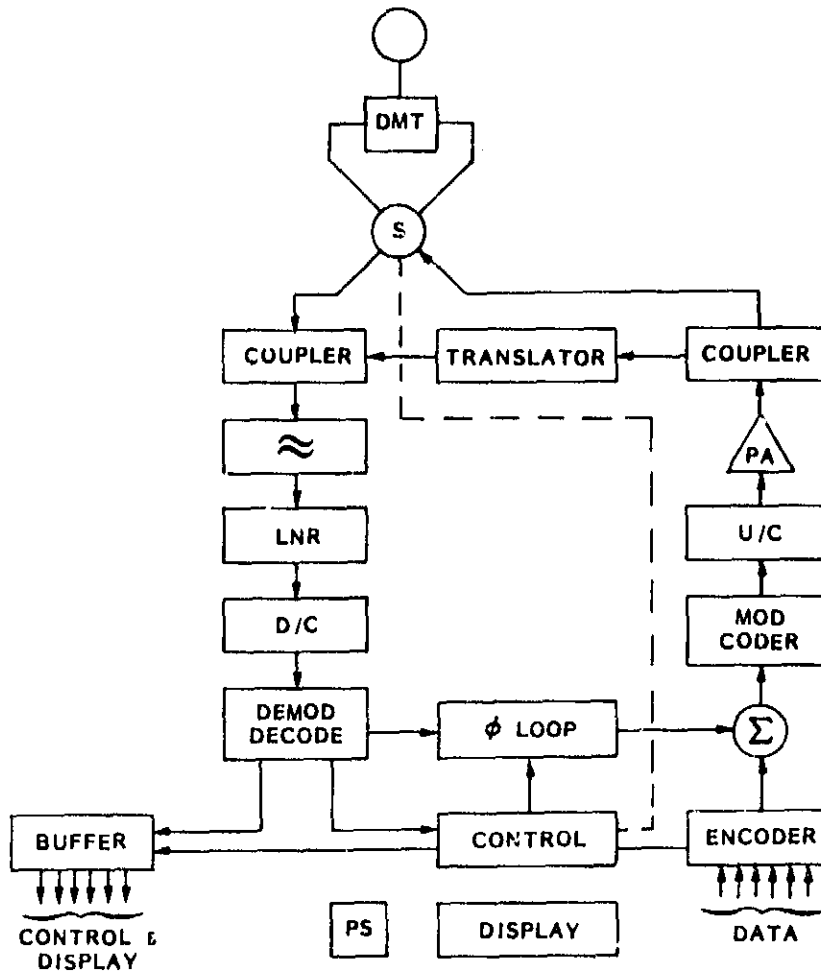

Figure 4.6-5. Interactive Data Transceiver

Incoming traffic from the mobiles, because it is responsive to interrogation also is TDM except for mobiles transmitting spontaneously because of alarms. The NOC can keep track of mobile response times (guard times), schedule routine traffic to avoid blocking, respond to priority situations and allow for alarms (a special code can be periodically sent requesting alarm messages, if any, along with network transmission "gaps" to avoid collisions).

Many applications are foreseen for such a generic transceiver in transportation, prospecting, law enforcement, environmental control, etc. The units are expected to be very low cost because they are simple, fixed tuned, low data rate devices with minimal processing and storage capability and are mass produced.

4.6.1.5 Signalling Architecture

ORIGINAL PAGE IS
OF POOR QUALITY

4.6.1.5.1 Cellular Signalling Architecture

This architecture is designed to provide telephone signalling functions in the presence of multipath fading, RF shadowing, and substantial co-channel and adjacent channel interference. The network, depicted in Figure 4.6-6 consists of a Mobile Telecommunications Switching Office, MTSO, various cell sites connected to the MTSO by land line communications (telephone lines), and mobile telephone users, communicating to individual cell sites via radio in the 806-890 MHz band.

Each subscriber is identified by a 10 digit telephone number (34 bits). Pre-origination dialing is used in which the destination address is first retained while supervisory dialing and various functions are being completed; the transceiver goes "off-hook" when they are completed, in order to assure efficient signalling. In a mobile radio system signalling is concerned with more than just a voice connection between the called and calling parties because of the propagation problems (multipath fading, RF shadowing,

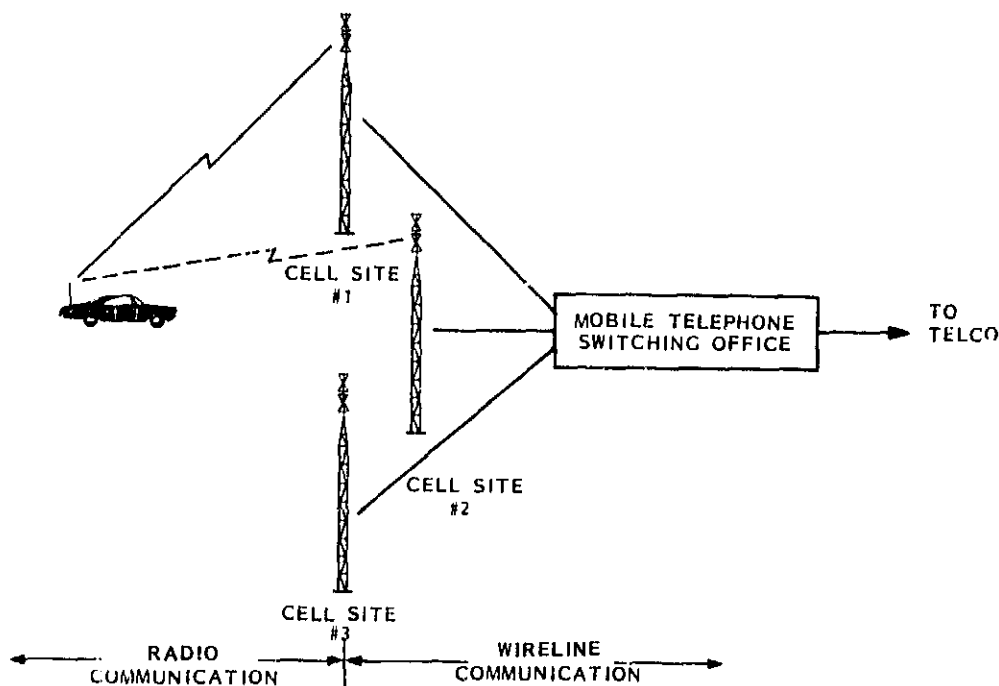

Figure 4.6-6. Typical Terrestrial Mobile Radio System

co-channel and adjacent channel interference, hand-off and the problem of roamers). Three aspects are important, supervision, paging (addressing a mobile) and access (addressing a land telephone). Supervision is concerned with the "hook" status which is common to conventional telephone networks, but also, for the mobile case, with signal strength (control of mobile power to limit interference and to maintain adequate signal) as the mobile traverses the network and with instructions concerning the characteristics of the network, that is local to the mobile. Supervisory functions are provided by a combination of special "set-up" channels, equivalent to common signalling channels which communicate to and from the mobile at a 10 KBPS rate (actual throughput is much less, about 1200 BPS, due to message redundancy to combat fading, other transmission inefficiencies, and supervisory signals). Supervisory signals are in-band frequency modulated tones. A signalling tone (ST) is used in the mobile-land direction for messages relating to alerting, hand-off, disconnection and flashing. A supervisory audio tone (SAT), either 5970/6000, or 6030 MHz is used to indicate circuit continuity, similar to DC continuity in conventional telephone systems (they are also used to measure the range to a mobile to aid in hand-off). These "in-band" signals are outside the voice bandwidth and are not discernible to users.

Paging (addressing a mobile) is a special problem because the mobile can be anywhere in a mobile service area. For that matter the mobile may not even be within the cellular system, (a problem the satellite could help solve). Lacking knowledge of its whereabouts, the mobile must be paged (its call number sent) via every call site in the Mobile Service Area (MSA). The paging message also contains an "overhead" message consisting of MSA identification (area call sign), the cell site SAT identification (only one of three SAT's is used per cell site), the number "N" of setup channels, "CMAX" which identifies the setup channels in use, and "CPA" which indicates whether paging and access share the same channels. The overhead message varies according to the site and MSA. For example very small cells and therefore, complex control instructions, are needed in an area containing New York City whereas only a single cell and simple control instructions (e.g., no hand-off complications) are needed for a small city.

ORIGINAL PAGE IS
OF POOR QUALITY

Access (addressing a land telephone) is accomplished via the setup channels by informing the system of the mobile's presence and ID, (which is performed as soon as the mobile is energized or enters a new cell), and its calling number. A typical channel is established by the following procedure:

1. Mobile scans the top 21 channels, picks the strongest and reads the "overhead" message which identifies the MSA and cell site and its set of setup channels, ("N").
2. To get pages it scans the appropriate set of N channels to get strongest channel, and to await pages.
3. For calling it locks onto an appropriate channel (which transmits a "busy/idle" bit, in the mobile direction), transmits a precursor message, examines the "busy/idle" bit for information and then signals, and waits. The busy/idle bit essentially provides a contention window; if successful the mobile can transmit its access message, if not successful the mobile must try again. This procedure reduces message collisions.
4. The MTSO responds by assigning a channel pair, transmits a precursor message, examines the "busy/idle" bit for information and then signals, and waits.
5. The cell site SAT is transponded through the mobile to confirm connection and then the mobile goes "off-hook".
6. Dial tones, etc., are provided to emulate the conventional telephone system.

The key to successful operation is the common signaling channel provided by the combination of the "setup channels" and the ST and SAT. AT&T estimates a maximum capability of 25 messages per second, or 90,000 per hour, e.g., 90,000 customers per busy hour per paging stream.

AT&T also estimates, based on its mobile telephone experience, that a mobile network should generate one call per subscriber in the busy hour and that one call per second will have to be handled in the smallest cells. The answer rate from a mobile is 0.5, and 60% of the calls are mobile originated. Four mobiles are "home" for every one roamer.

4.6.1.5.2 LMSS Signaling Architecture

There are significant differences between LMSS and cellular signaling. For one, the satellite cells are much larger, probably fewer (may just be one), the signal levels over the propagation path are constant (relatively little fading) and the problem of co-channel and adjacent channel interference is

much more tractable. Shadowing must be accepted, as in the terrestrial system, but its effect on signalling or communication can be ignored as far as architecture is concerned.

Another difference is the diversity of services offered by the satellite which involves signals of different bandwidths, modulation formats, etc., which the signalling system must contend with because flexibility is inherent in a satellite system. The cellular system on the other hand is limited to formats consistent with the telephone system wire line and switching hierarchy.

The satellite system also is evolutionary; the signalling system must adapt to cell division just like the cellular system, and also adapt to other changes as the system evolves. For example, multiple beam antennas can alter the bandwidth and/or the spectrum assigned to the gateways (as indicated in the satellite evolution progression discussed previously), so that it is important to maintain the integrity of the signalling system despite these changes.

Just as in the terrestrial system, signalling is vital to efficient, orderly LMSS operation. Unlike the telephone system which traditionally has limited signalling when off-hook, a satellite system can provide a continuously available signalling channel for positive network control at relatively little additional cost. Consequently, SCPC-DAMA systems, including Intelsat's SPADE system, provide continuously available signalling.

This plan is adapted for LMSS so that the NOC retains positive control of all network functions, at all times. Therefore, in emergency situations calls can be prioritized or interrupted and disconnected and blocked (from radiating), and unauthorized users or users with injurious out-of-spec performance can be denied access (prevented from radiating). Also, the common signalling channel received by the mobile can be used to measure signal strength, CNR, and presence of multipath so these can be signalled back to the NOC for appropriate actions. In addition, the LMSS signalling system from the NOC outward is exclusive to the NOC, (not shared), and is efficiently utilized in the TDM mode. The NOC, the central control for all the networks, has positive control over the mobiles and the gateways. On the other hand, mobile signalling (toward the NOC) is contention access, e.g., slotted ALOHA, but, contention is only amongst the mobiles. The same is true for the gateways.

**ORIGINAL PAGE IS
OF POOR QUALITY**

**ORIGINAL PAGE IS
OF POOR QUALITY**

Finally, the common signalling channel also provides AGC (VOX operation and SSB prevent the use of communication signals for the purpose of deriving AGC), and a continuous carrier for step track antenna steering in those transceivers requiring it. A likely additional function is as a frequency reference for the CSSB transceivers. Common signalling channel characteristics are summarized in Table 4.6-2.

In addition to the sender and destination identification, provisions are made to identify the power and bandwidth required and to indicate the carrier level (of the common signalling channel) being received and the HPA level being transmitted. This enables system dynamic response to service requests and can provide adjustments for individual user's equipment performance (antenna gain for example) and to provide a constant eirp. Three bits are allowed for standard messages such as a priority message or a defective equipment alert (observed and sent by NOC), etc. Additional bits are added for the gateway - NOC link to telemeter gateway status to enable effective routing in the case of a failed gateway or for maintenance assist, (at least some gateways will likely be owned by the satellite system operator).

Table 4.6-2. Common Signalling Channel Characteristics

| | MOBILE-NOC | NOC-MOBILE | GATEWAY-NOC | NOC-GATEWAY |
|---------------------------|------------|---------------|-------------|---------------|
| ID | 34 | -- | 34 | -- |
| ADDRESS | 34 | 34 | 34 | 12 |
| CARRIER LEVEL | 3 (CSC) | 3 (HPA LEVEL) | 3 (CSC) | 3 (HPA LEVEL) |
| POWER/BANDWIDTH NEEDED | ? | - | 2 | - |
| CHANNEL SELECTION | - | 12 (4096 MAX) | - | 12 |
| STATUS | - | - | 20 | - |
| SPECIAL STANDARD MESSAGES | 3 * | 3 ** | 3 * | 3 ** |
| SYNC | <u>20</u> | <u>20</u> | <u>20</u> | <u>20</u> |
| SUBTOTAL | 96 | 72 | 116 | 50 |
| CODING (RATE 3/4) | <u>32</u> | <u>24</u> | <u>39</u> | <u>17</u> |
| TOTAL | 128 BITS | 96 BITS | 155 BITS | 67 BITS |

It should be noted that both FM and SSB have provisions of inband signalling. In the FM case, 6 KHz tones (5970, 6000, 6030 Hz for "supervisory audio tone") and a 10 KHz signalling tone are used. In SSB, a 3600 Hz modulated pilot tone is planned for AGC, AFC, companding and about 20 PPS of signalling.

The common signalling channel should have a high CNR; while significant fading should only be experienced in urban areas due to building reflection, nevertheless a high CNR is relatively inexpensive to provide and assures positive network control. There should be no co-channel or adjacent channel interference. BPSK with rate 3/4 convolutional coding with hard decision is effective and inexpensive. A minimum CNR = 8dB results in a decoded BER = 10^{-4} which results in negligible errors compared to blocking and unattendance. The typical CNR should be much higher, perhaps CNR = 18 dB.

The common signalling channel is not cellular compatible but is designed to meet the requirements of a satellite system. It is possible to use the cellular system signalling arrangement for the cellular - compatible radio telephone network. Even so, some modifications are required (modification for VOX operation is needed to minimize satellite costs). Retaining the noncoherent FSK system in a 30 KHz channel is not a major problem for the satellite link, although the cost of a 30 KHz signalling channel may be significant if only a few 30 KHz channels are required for cellular - compatible radio telephone. However, repetitive bursting to overcome terrestrial Rayleigh fading is not needed in a satellite channel. Consequently, it is clear that the FSK arrangement can be retained, however, some modifications in any case will be required.

4.6.2 MOBILE ANTENNAS

ORIGINAL PAGE IS
OF POOR QUALITY

4.6.2.1 Introduction

Various mobile vehicle antennas are required to satisfy the requirements of a land mobile satellite system. The three generic service types, radio telephone, dispatch and interactive data/position location can make use of both fixed and steered antennas. In addition the antennas must be capable of convenient mounting on cars, trucks, trains, boats, etc. yet be esthetically pleasing, have low windage and be reasonably vandal-proof. An additional requirement exists for a relatively small antenna capable of being conveniently carried by a pedestrian. Four basic antenna types are discussed:

1. Fixed (low gain) antenna.
2. Electronically steered antenna.
3. Mechanically steered antenna.
4. Fixed, pedestrian - compatible antenna.

ORIGINAL PAGE IS
OF POOR QUALITY

Even higher gains can be achieved for the steered antennas by "arraying" additional elements. Such an application might be for oil well logging where the mobile is stationary when communicating.

The following sections first describe the antenna requirements, and then antenna concepts satisfying the four basic antenna types identified above.

4.6.2.2 Mobile Vehicle Antenna Requirements

The basic RF requirements for the mobile vehicle antenna are that it be circularly polarized with reasonably good polarization isolation and operate over the 821 to 831 Mhz band for transmit and the 866 to 876 MHz band for receive. For some applications such as ranging for location determination, dual circular polarization operation is desirable and may be either switchable or simultaneous.

The mobile vehicle antenna should also have good ground multipath rejection, moderate forward gain (up to 10 dBi), and low ground illumination and back lobes. Good multipath rejection is essential to minimize both cross-polarized and direct interference. The antenna pattern should therefore be well controlled with a sharp fall off at low elevation angles and have low back lobes in order to reduce multipath reception, obtain good man-made noise rejection, and provide a low antenna thermal noise temperature.

It is highly desirable to have the cross polarization level as low as is consistent with a simple low-cost design. This requires a low axial ratio (in dB), which is not easy to obtain over a wide coverage angle. A plot of polarization isolation versus axial ratio is shown in Figure 4.6-7, from which it is seen that a polarization isolation of 20 dB requires an axial ratio of only about 1.8 dB while an axial ratio of about 5.7 dB reduces the polarization isolation to only 10 dB. A major source of interference between channels is thus direct cross-polarization excitation due to the axial ratio

of the mobile vehicle antenna. The other source is multipath and ground reflection, which partially (or completely) reverses the sense of polarization. For example, if the polarization isolation is 20 dB for a direct signal and the level of a cross-polarized ground reflection signal is also -20 dB, the maximum cross coupling for in-phase signal addition is -14 dB.

The antenna noise temperature is the temperature distribution of all the space surrounding the antenna weighted by the antenna relative power pattern. For those directions above the horizon, the noise source distribution consists of galactic plus atmospheric noise, as shown in Figure 4.6-8, which corresponds to about 40⁰K or less at 850 MHz for elevation angles above 10⁰ and increases to about 100⁰K at lower elevation angles. For those directions toward the ground, a ground temperature of 290⁰K may be used and weighted by the average backlobe and main lobe ground illumination.

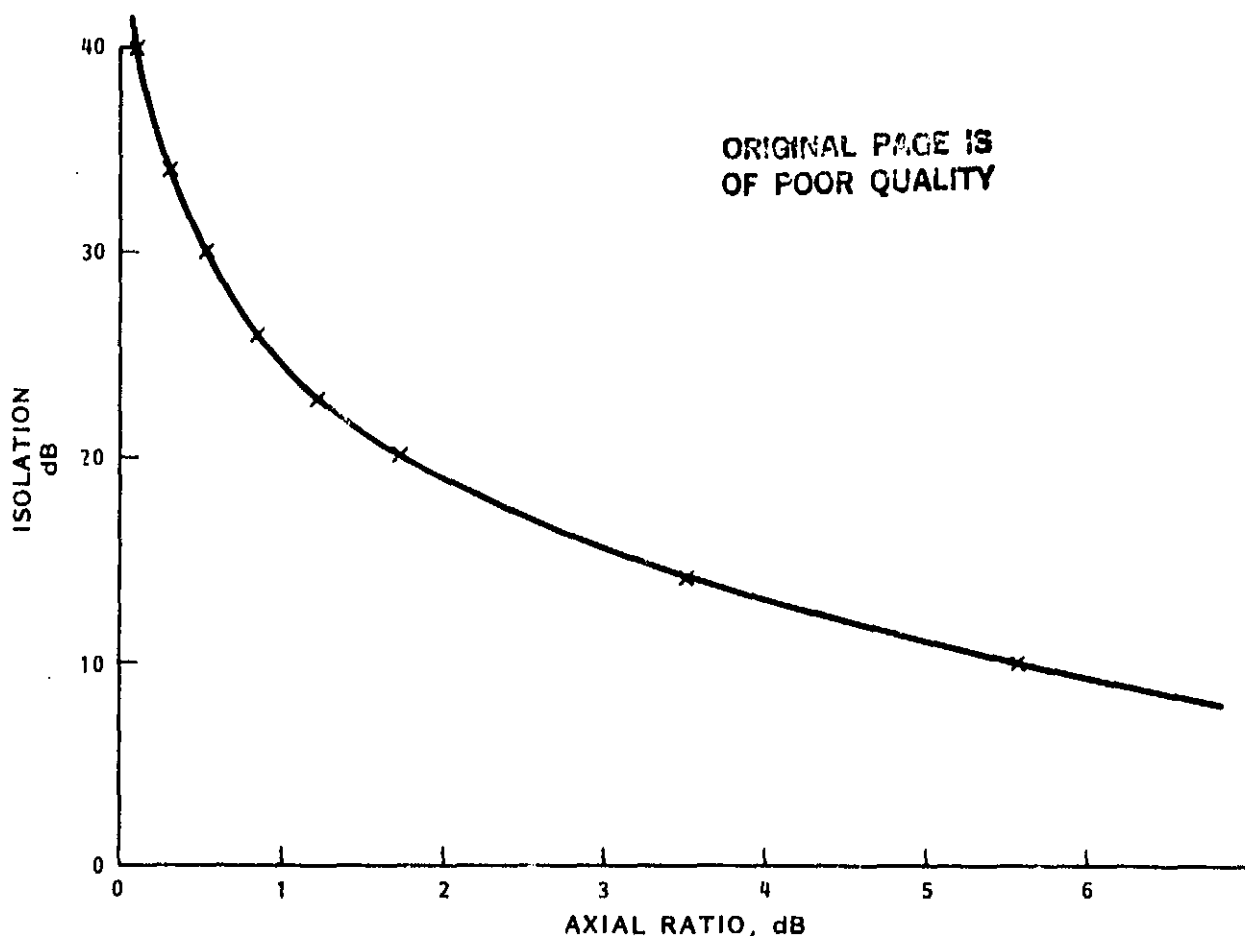

Figure 4.6-7. Polarization Isolation versus Axial Ratio

The pattern coverage angle should permit operation with satellites at both the $90^{\circ}W$ and $120^{\circ}W$ longitude positions, either separately or simultaneously. For steerable mobile vehicle antennas, only wide elevation coverage is required with a narrower azimuth beam since it is assumed that the antenna is steered only in azimuth by step track using the common signalling channel signal level as a reference.

The mobile vehicle antenna must also be compatible with a variety of vehicle types such as cars, trucks, and boats. It should also be of rugged construction and have a preferably low profile, thus it should be relatively flat and have a protective cover or radome. Finally it is important that the mobile antenna have a relatively low cost for a given performance.

The principal parameters for the mobile ground terminal-to-satellite geometry were calculated to determine the antenna coverage angle requirements. This geometry is shown in Figure 4.6-9 together with the basic relationships. The inputs required are the longitude of the satellite position, and the latitude and longitude of the ground station.

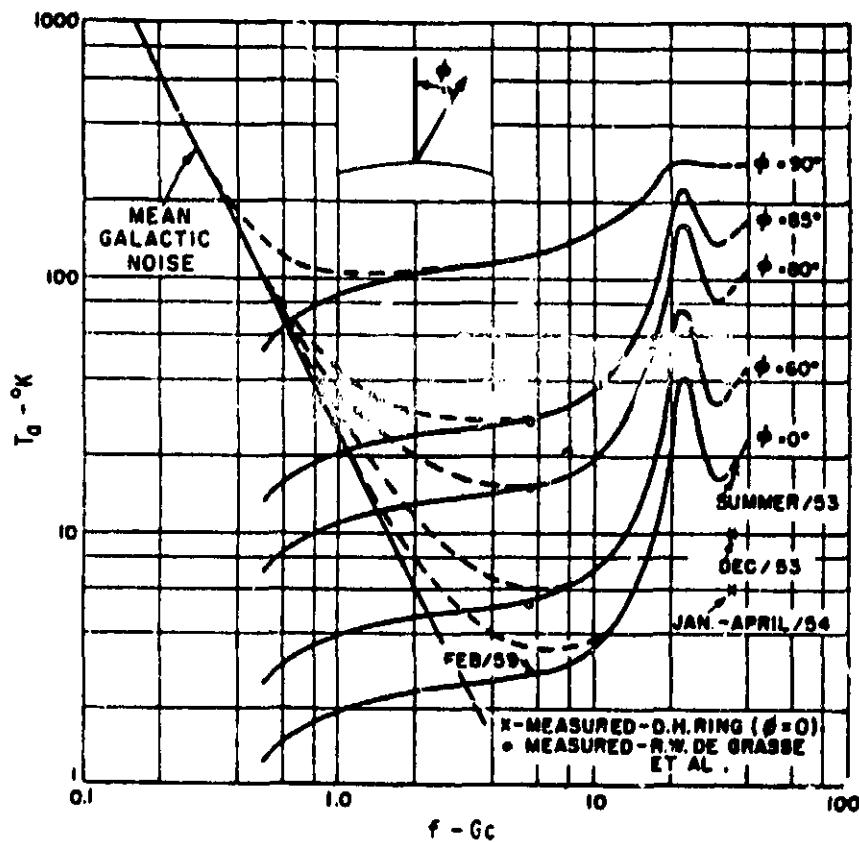
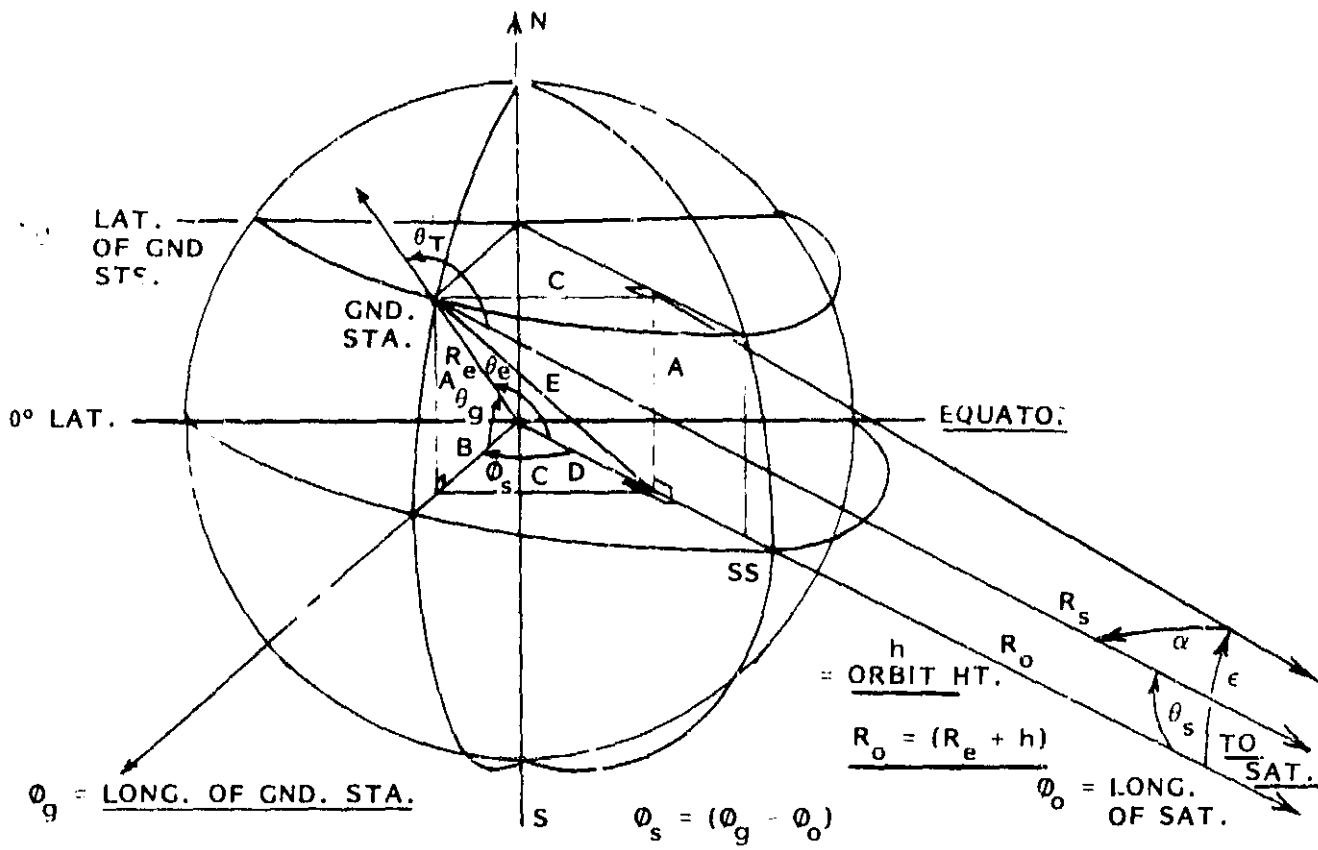

Figure 4.6-8. Equivalent Atmospheric Temperatures as a Function of Frequency and Angle From Azimuth



$$A = R_e \sin \theta_g$$

$$B = R_e \cos \theta_g$$

$$C = B \sin \phi_s$$

$$D = B \cos \phi_s$$

$$E = \sqrt{A^2 + C^2}$$

$$\theta_s = \text{ARCTAN} \frac{E}{(R_o - D)}$$

$$\theta_e = \text{ARCSIN} \frac{E}{R_e}$$

$$\theta_T = \theta_e + \theta_s$$

$$R_s \frac{R_e \sin \theta_e}{\sin \theta_s} = \frac{E}{\sin \theta_s}$$

FOR AZ. OVER ELEV. MOUNT ON SAT.:

- ELEV. ANGLE E MEAS. IN PLANE THRU N-S

- AXIM. ANGLE MEAS. IN ELEVATED PLANE

$$\epsilon = \text{ARCTAN} \frac{A}{(R_o - D)}$$

$$\alpha = \text{ARCTAN} \frac{C}{\sqrt{A^2 + (R_o - D)^2}}$$

$$= \text{ARCSIN} \frac{C}{R_s}$$

Figure 4.6-9. Antenna Geometry

The coverage angle parameters were calculated for several locations over CONUS, Hawaii, and Alaska. A summary of these results is given in Table 4.6-3.

It is seen from these results that CONUS coverage requires a range of ground station elevation angles of 60° to 15° to cover both satellite positions. Hawaiian coverage for the 120° W satellite position is already included within the CONUS coverage angle range, and can be obtained for the 90° W satellite position by extending the coverage angle to about 10° elevation. Alaskan coverage can be obtained along the southern portion from the 120° W satellite position with the CONUS coverage angle, but a coverage angle of about 5° elevation is required for the northern portion. The latter angle is required to cover even the southern portion of Alaska for the 90° W satellite position.

Table 4.6-3. Range of Coverage Angles

| | 90°W SATELLITE | 120°W SATELLITE | COMMENTS |
|----------------------|----------------|-----------------|---|
| MAINE/NE | 58.61° | 73.85° | CONUS RANGE = 31.4° TO 73.9° |
| WASH/CANADA | 64.46° | 56.30° | |
| PACIFIC | 64.78° | 55.75° | |
| CALIF/SW | 47.90° | 37.94° | |
| FLA/SE | 31.44° | 52.95° | |
| TEXAS/SO TIP | 31.44° | 39.58° | |
| HAWAII/NW | 80.11° | 51.64° | |
| MID | 78.04° | 49.21° | |
| SE | 74.92° | 45.66° | |
| ALASKA/PT. BARROW | >90° | 84.37° | S AND SE WITHIN CONUS RANGE FOR 120°W SATELLITE; EXTENDS TO 84.4° FOR PT. BARROW; MOST LOCATIONS OVER HORIZON FOR 90°W SATELLITE |
| NW | >90° | 84.18° | |
| W | >90° | 80.87° | |
| ALEUTIAN TIP | >90° | 80.66° | |
| S | 83.56° | 72.64° | |
| SE | 72.22° | 63.38° | |

4.6.2.3 Fixed Antenna Concept

The fixed mobile vehicle antenna is the most difficult design in several respects. First, the antenna must have an omnidirectional pattern in azimuth in addition to the wide coverage angle required in elevation. Second, this antenna is intended for ranging with both satellites to determine vehicle location, thus both satellites must be in view of the antenna and it must have dual circular polarization (somewhat higher gain and a simpler configuration results if the antenna must view just one satellite, this case was not examined). As a result, the types of antennas to be considered as candidates are quickly narrowed to only a few.

Various candidate antenna types that were considered for the fixed mobile vehicle antenna are illustrated in Figure 4.6-10. These are the crossed dipole over a ground plane, the short axial mode helix, the Archimedean spiral, the short crossed yagi, and the cavity-backed crossed slot. A list of these antennas is given in Table 4.6-4 with their principal characteristics and advantages/limitations.

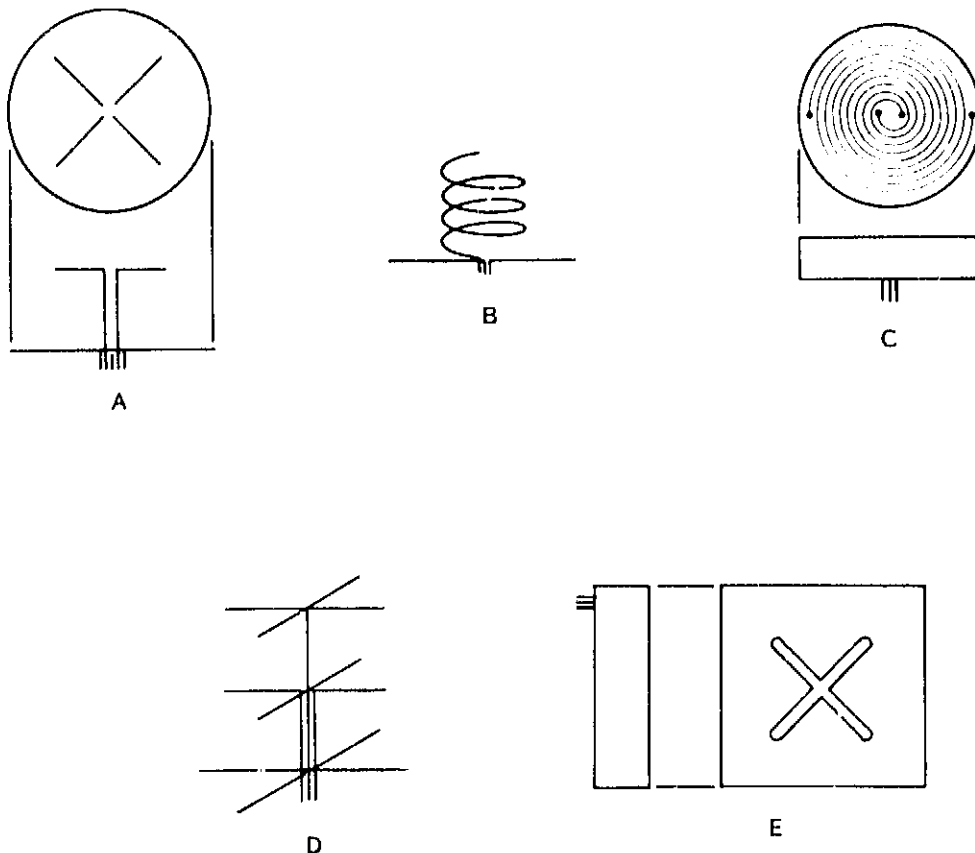

Figure 4.6-10. Candidate Fixed Antennas

Table 4.6-4. Fixed Antenna Characteristics

| CANDIDATE | PRINCIPAL CHARACTERISTICS/ADVANTAGES/ LIMITATIONS |
|-------------------------------------|--|
| CROSSED DIPOLE OVER GROUND PLANE | DUAL POLARIZATION BEAMSHAPING POSSIBLE AXIAL RATIO LIMITED MODERATE WEIGHT BULKY |
| SHORT AXIAL MODE HELIX | SINGLE POLARIZATION LIMITED BEAMWIDTH AXIAL RATIO LIMITED LIGHT WEIGHT COMPACT |
| ARCHIMEDEAN SPIRAL | SINGLE POLARIZATION LIMITED BEAMWIDTH AXIAL RATIO LIMITED LOW PROFILE BULKY |
| SHORT CROSSED YAGI | DUAL POLARIZATION BEAMSHAPING POSSIBLE AXIAL RATIO LIMITED LIGHT WEIGHT BULKY |
| CAVITY BACKED CROSSED SLOT | DUAL POLARIZATION LIMITED BEAMWIDTH AXIAL RATIO LIMITED LOW PROFILE HEAVY BULKY |

These candidate antennas fall into two basic classes: (1) those that are inherently circularly polarized and only produce a single polarization, and (2) those that are composed of linearly polarized elements and can provide dual circular polarization when fed by a dual input to a -3 dB 90° hybrid. The helix and spiral fall into the first category, while the crossed dipole, crossed yagi, and crossed slot fall into the second. The helix or spiral antenna can meet the dual polarization requirement by using a pair of such antennas to provide right and left hand circular polarization. All candidates are limited in axial ratio performance because of the wide coverage angle.

The gain of an antenna having such a large coverage area is inherently low, but beamshaping techniques can be employed with some of the candidates to improve the gain over the desired coverage angles. Several basic elevation patterns are shown in Figure 4.6-11 for antennas having omnidirectional coverage in azimuth (i.e., the patterns are rotationally symmetric about the Z axis). The idealized pattern of Figure 4.6-11a is not attainable in practice, but it permits a maximum reference gain to be calculated for a specified coverage. Using the values of $\theta_1 = 30^\circ$ and $\theta_2 = 75^\circ$ from the

previous section, an ideal reference gain of 5.18 dBi is obtained. In practice, the edge of coverage gain is roughly 3 dB below the ideal, or about 2 dBi in this case. Furthermore, if the pattern has a more nearly hemispheric coverage as in Figure 4.6-11d, the edge of coverage gain at $\theta_2 = 75^\circ$ is more likely to be about 1 dBi or less.

The helix and spiral antennas have beamwidths that are not as great as required for the fixed mobile vehicle antenna. For most applications, helices are designed with four to six (or more) turns and produce the narrower beam type of pattern shown in Figure 4.6-11c, for which a good axial ratio can be obtained over the narrower beamwidth. To even approach the beamwidth required here, the helix requires only about two turns, which seriously impairs its performance. The spiral antenna has a cosine type pattern shown in Figure 4.6-11b, which has a gain of only -4.0 dBi at $\theta_2 = 75^\circ$ and is not only too narrow but can not be easily shaped.

The simple crossed dipole and the crossed slot antennas both produce wide angle coverage and can be designed to have excellent axial ratio on axis, but the polarization becomes linear at wide angles. Furthermore, the crossed slot antenna is bulky and heavy at UHF because of the cavity. The polarization limitations of the crossed dipole at wide angles can be partially overcome by bending the dipoles toward the ground plane. This introduces axial components of current which help maintain a better axial ratio over a wider coverage angle. Such bent crossed dipole antennas are current state-of-the-art for spacecraft TT&C applications.

While the short crossed yagi is light weight, it has the same degradation in axial ratio at wide angles as its component crossed dipoles. This limitation can be overcome, however, by using the bent crossed dipoles mentioned above as elements for the yagi array. Furthermore, a short crossed yagi has the potential of being adjusted to produce the desired butterfly type pattern shown in Figure 4.6-11e rather than a broad endfire pattern. It is also possible that the short crossed yagi can be modified to a fully driven array for better beamshaping control over the required coverage angle. These ideas are worth further development to determine what can be achieved.

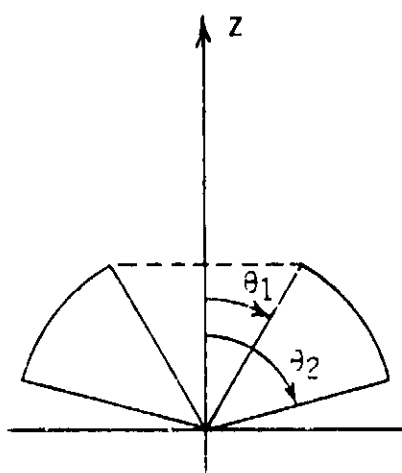

a. IDEALIZED PATTERN

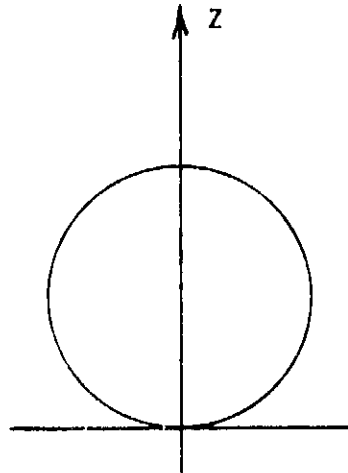

b. COSINE PATTERN

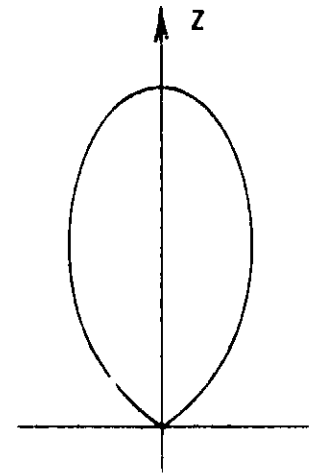

c. BEAM PATTERN

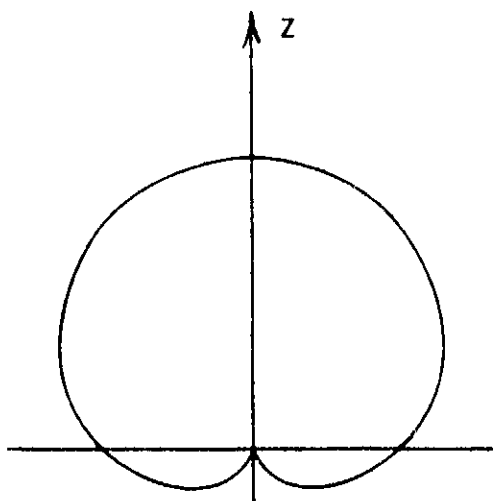

d. CARDIOID PATTERN

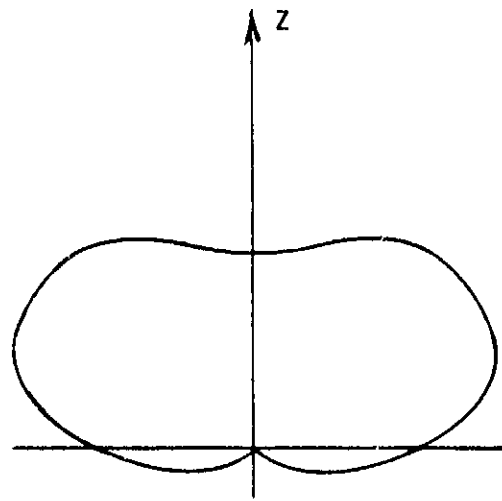

e. BUTTERFLY PATTERN

Figure 4.6-11. Typical Elevation Pattern For Antennas Having Omnidirectional Coverage in Azimuth

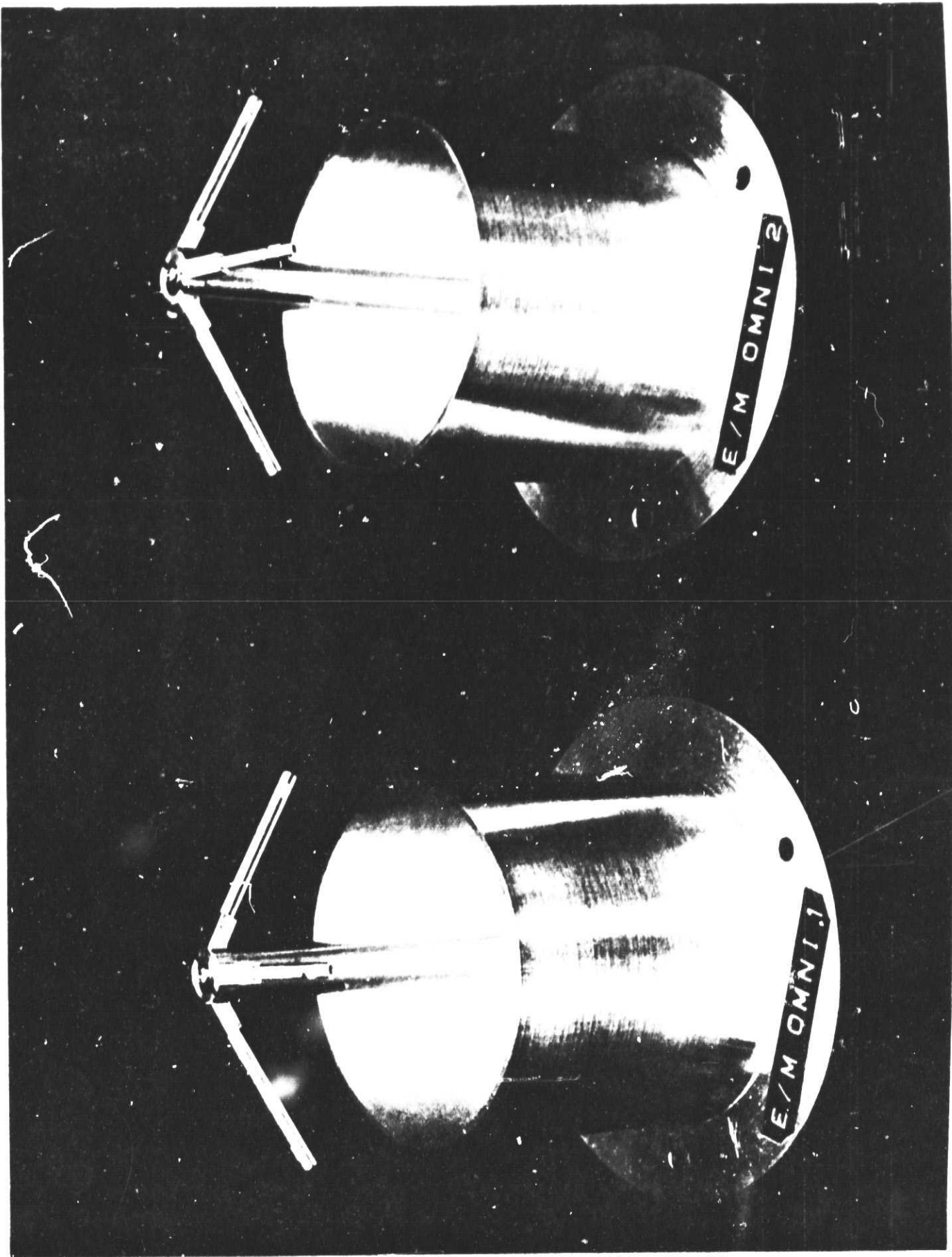

Figure 4.6-12. Bent, Crossed Dipole Antenna and Cup

Based on the above considerations, a bent crossed dipole over a cupped or conical ground plane was selected as the baseline concept for the fixed mobile vehicle antenna. A photograph of engineering models of such an antenna is shown in Figure 4.6-12. This antenna was developed and space qualified at S-Band for the TT&C system on Landsat-D. It uses a split coaxial balun with unequal dipole lengths to produce a single right-hand circular polarization.

For the fixed mobile vehicle antenna, equal dipole lengths can be used with a symmetrical four-coax type balun and a 90° hybrid to produce both right and left-hand circular polarizations. An outline sketch of this design with approximate dimensions for UHF operation is shown in Figure 4.6-13. The crossed dipoles are somewhat higher (relatively) than at S-Band to obtain some beamshaping, as discussed below.

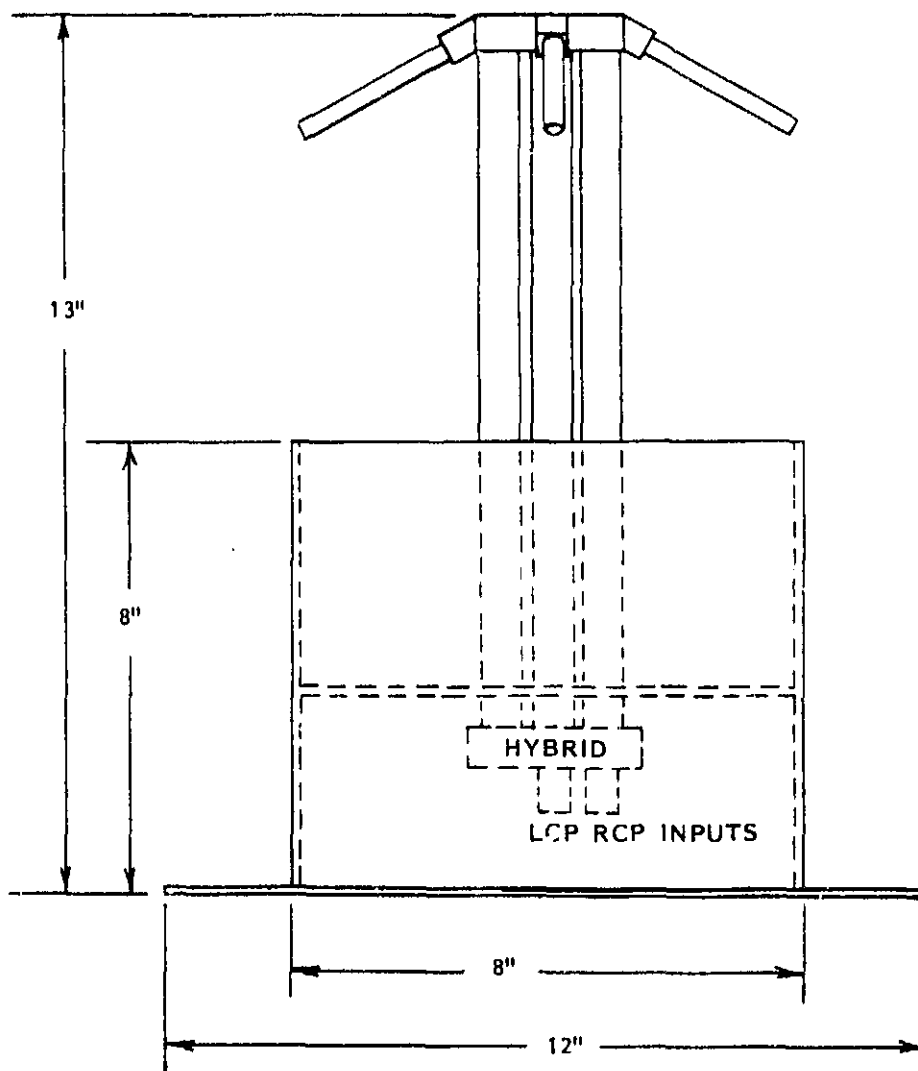

Figure 4.6-13. Fixed Antenna Concept Sketch

Patterns measured at two S-Band frequencies on the antenna pictured in Figure 4.6-12 are shown in Figures 4.6-14a and 4.6-14b. These patterns were taken with a spinning linearly-polarized source antenna, which permits the axial ratio to be determined directly from the upper and lower envelopes of the pattern. The axial ratio varies from about 1.2 to 1.6 dB at 0° for the two frequencies to about 5 to 6 dB at $\pm 75^\circ$, which corresponds to a range of polarization isolation from about 23 to 21 dB to about 11 and 9 dB, respectively. The corresponding RCP gain varies from about 5 and 4 dBi at 0° to about 0 and 0.5 dBi at $\pm 75^\circ$.

The shapes of these patterns can be controlled to be more like the desired butterfly shaped pattern of Figure 4.6-11e by increasing the crossed dipole height over the ground plane. This reduces the gain on axis but increases it at wider angles. With proper adjustment, the gain will dip 3 or 4 dB on axis and rise to a maximum near $\pm 50^\circ$ with near equal gains of 1 to 2 dBi obtained at $\pm 30^\circ$ and $\pm 75^\circ$. With equal dipole lengths, the axial ratio also is better controlled and can be adjusted to favor the wider coverage angles required.

Another possibility for shaping the beam and also for minimizing the ground illumination is to use the bent crossed dipole over a conical ground plane. Such a ground plane is made up of several conical frusta segments to control the beam shape. This was done very successfully for the direct readout S-Band communications antenna developed for Landsat-D. The latter required a greater amount of beamshaping than is needed for the fixed mobile vehicle antenna and was accomplished with a 12-inch diameter ground plane. This corresponds to a 31-inch diameter ground plane at UHF, but the diameter might be reduced to about 24 inches or less as a trade-off for some increase in ground illumination.

The noise temperature of the fixed mobile vehicle antenna will depend to a large extent on how well the beam shape can be controlled to limit ground illumination. For the idealized pattern of Figure 4.6-11a, the antenna noise temperature is only about 36°K . As a more realistic reference value, however, the cardioid pattern of Figure 4.6-11d has an antenna noise temperature of about 69°K . By shaping the pattern to improve the desired coverage and reduce ground illumination, an antenna noise temperature of 58°K might be realizable.

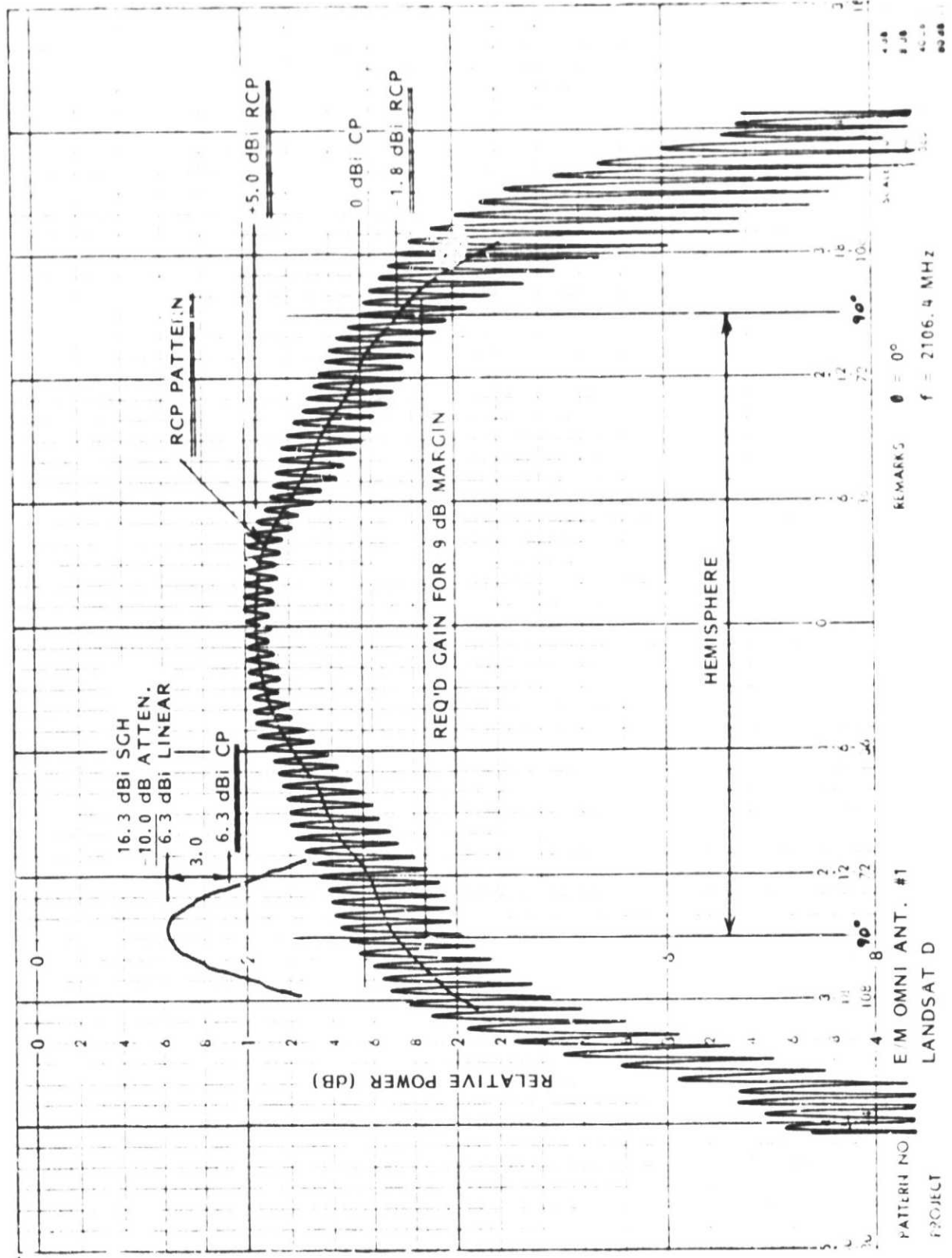

Figure 4.6-14. S-Band Patterns of Fixed Antennas (a) and (b)

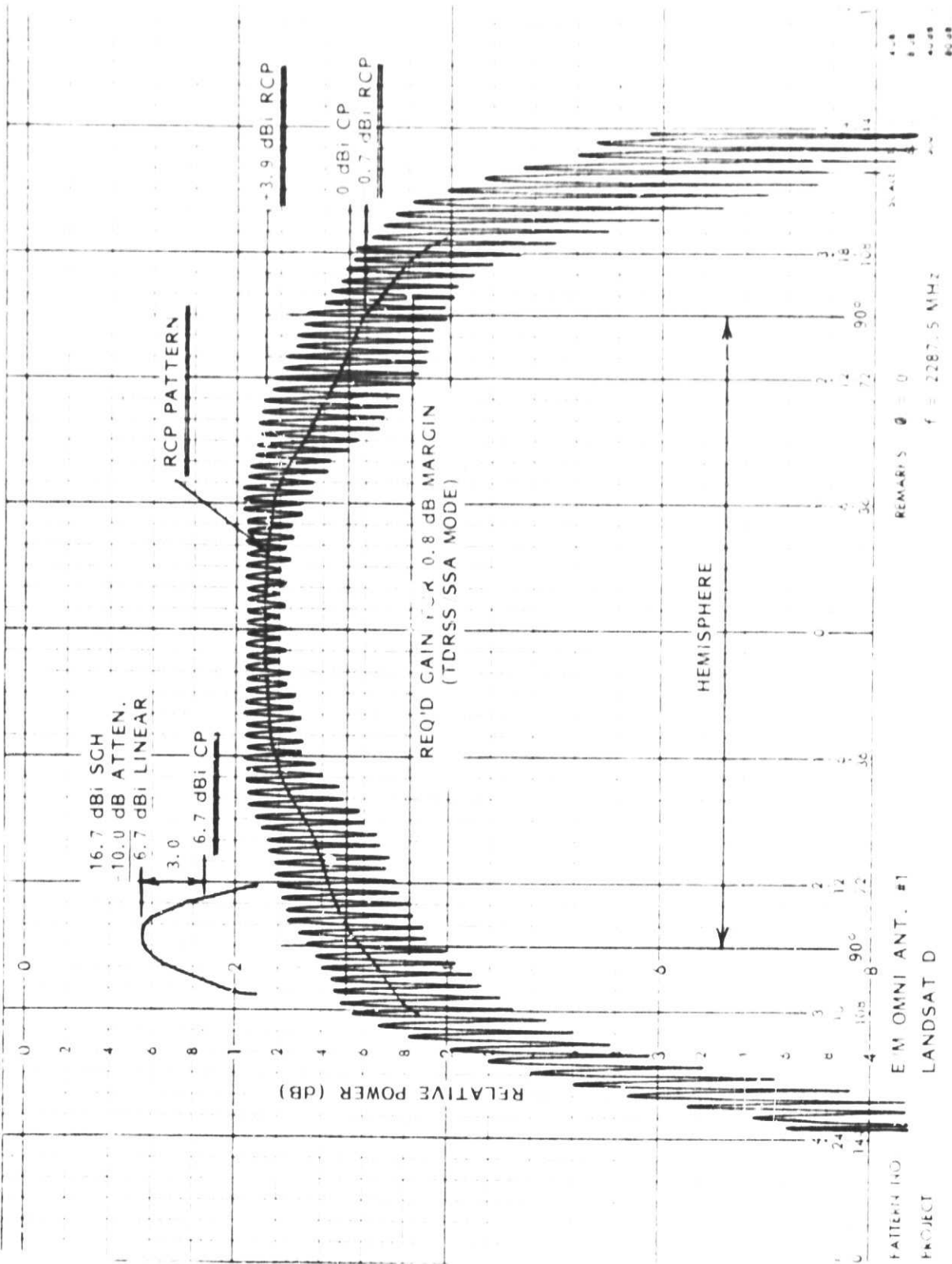

Figure 4.6-14. S-Band Patterns of Fixed Antennas (a) and (b) (Cont.)

4.6.2.4 Mechanically-Steerable Mobile Antenna Concept

The mechanically-steerable mobile vehicle antenna is simpler electrically at UHF than the fixed antenna in several respects. First, it has less total coverage required because it can be steered 360° in azimuth. The antenna pattern only has to cover 60° to 15° in elevation coverage angle. Second, it only operates with one satellite at a time, thus the antenna pattern coverage in azimuth can be relatively narrow. Third, the antenna can have a single left- or right-hand circular polarization. Selectable dual circular polarization is more versatile, and also is possible.

Mechanically, of course, this antenna is more complex than the fixed antenna since it must have a rotatable platform, RF rotary joint, motor and control electronics. Step track is envisioned using the common signalling channel carrier level.

Two candidates for the mechanically-steerable antenna are the axial mode helix and the cross yagi. Other candidates considered were the crossed dipole over a ground plane, the Archimedean spiral, and the cavity-backed crossed slot. These were ruled out because their broad antenna patterns require several elements to be arrayed and for the other reasons discussed in reference to Table 4.6-4 for the fixed antenna. The helix has only a single polarization, but it has a larger bandwidth than the yagi. The helix and yagi are both considered viable concepts for the mechanically-steerable antenna.

The axial mode helix and the crossed yagi antennas are illustrated in Figures 4.6-15a and 4.6-15b mounted on an azimuth platform and protected by a radome enclosure. In both cases, the elevation beamwidth required for CONUS coverage is about 45° . The elevation angle is 37.5° and the beamwidth is 52.5° . The yagi is shown with the 90° hybrid and coax polarization switch mounted on the rotating platform so that a single RF rotary joint can be used. Selectable dual polarization also can be obtained with a pair of left- and right-hand polarized helices mounted on the rotating platform with a coaxial switch. The latter may be the preferred approach for achieving dual circular polarization if bandwidth becomes a problem with the crossed yagi or if the cost is much lower. Both antennas are physically compact which facilitates installation.

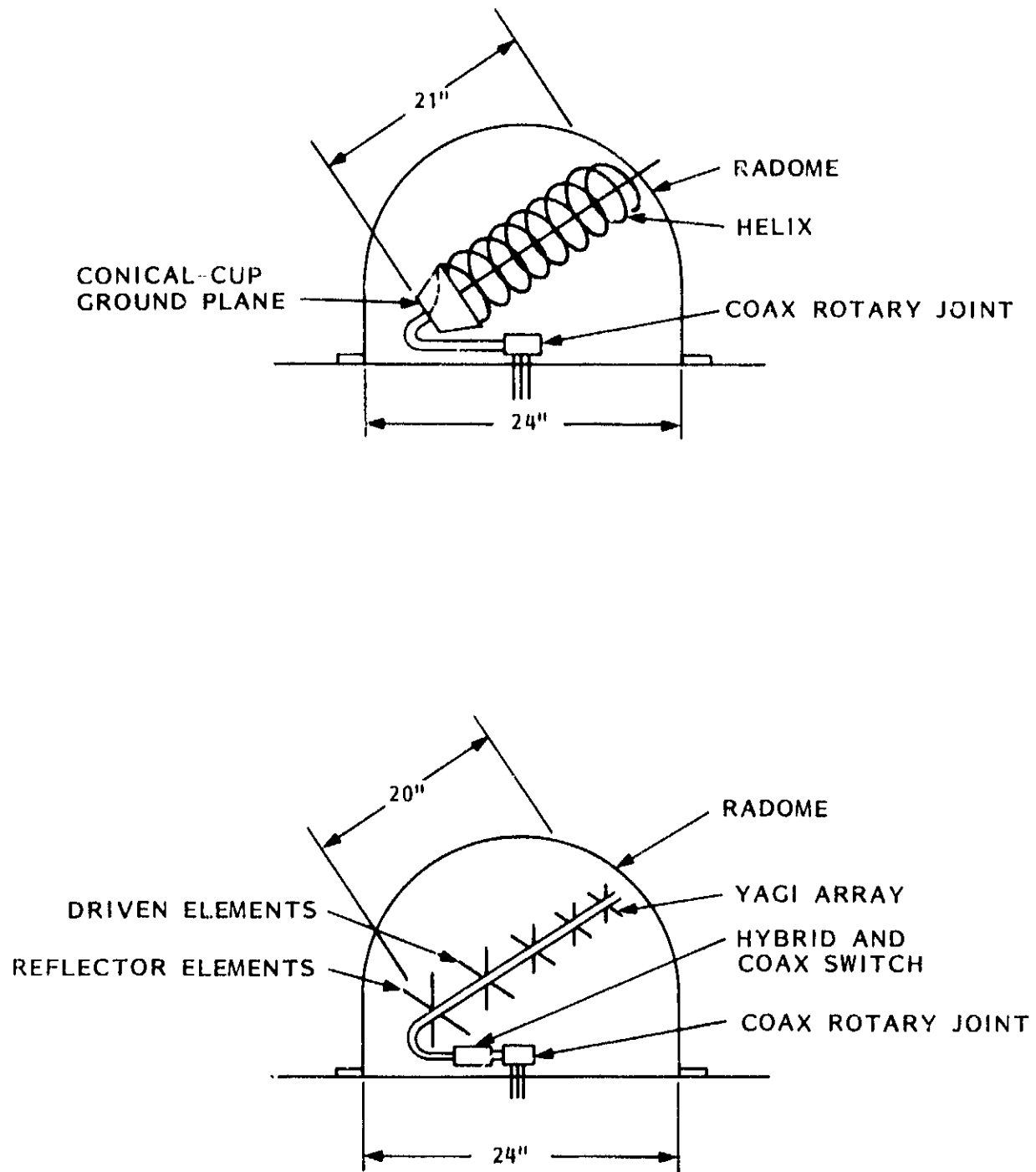

Figure 4.6-15. Helix (a) and Yagi (b) Steerable Antenna Concepts

For the axial mode helix, a -3 dB beamwidth of 45° is obtained with six turns and a 12.5° pitch angle. This gives an overall length of about 21 inches. The gain is about 13 dBi on axis, which gives an edge-of-coverage gain of about 10 dBi. Sidelobes and backlobes are minimized by using an optimized conical-cup ground plane, which also results in a compact assembly.

For the crossed yagi, one reflector and three directors are shown with about 0.34-wavelength spacing. The actual number of directors and the spacing needed to obtain low sidelobes and backlobes must be empirically determined during development. Careful attention must also be given to achieving the required bandwidth.

The axial mode helix and the crossed yagi antennas can both be made to have a relatively low axial ratio over the beamwidth and thus good polarization isolation. With well controlled sidelobes and backlobes, an antenna noise temperature of 50°K to 60°K is attainable.

4.6.2.5 Electrically-Steerable Antenna Concept

The electrically-steerable antenna has several conflicting requirements that are not easy to resolve with current state-of-the-art approaches. First, it is desirable for it to be of low profile and moderate area. Second, it should scan the beam electrically over 360° in azimuth and should have an elevation coverage of at least 60° to 15° for CONUS operation. Third, it should have reasonably good axial ratio over the beamwidth. Fourth, it must be relatively simple and low cost. These are difficult requirements to meet but some implementation possibilities do exist.

The microstrip array was the primary candidate antenna considered because of its low profile and simple construction. A great deal of work has been done recently on microstrip arrays, and much material has appeared in the literature⁽¹⁾. In general, it shows much promise, but still there are limitations on the coverage and performance that are attainable.

Scanning a narrow beam in elevation was ruled out because of the excessively large vertical aperture required to obtain a narrow elevation beam at UHF. Even a fixed beam in elevation with a beamwidth of 45° requires a projected

aperture height of about 21 inches at 37.5° from the vertical. To obtain this from a horizontal array requires an actual aperture length of about 35 inches, which is about as large as can be considered.

The basic antenna concept for a flat microstrip phased array (that is steered only in azimuth and non-steered in elevation) is shown in Figure 4.6-16. This array consists of 19 circularly-polarized microstrip patch elements arranged in a triangular grid over a 36-inch diameter ground plane. The effective element spacing is essentially one-half the actual element spacing, since microstrip elements radiate from two opposite edges of the patch. For circular microstrip patches the effective edge-to-edge dimension is somewhat less than the patch diameter. To achieve equal effective spacing between all elements edges, therefore, the element center-to-center spacing is slightly less than twice the microstrip element diameter.

In order to suppress the grating lobe the effective element-to-element edge spacing must be only about 0.3 wavelengths. An element center-to-center spacing of 0.6 wavelengths results in adequate lobe suppression of about -18.5 dB, but the array size is about 38.6 inches overall, which is too large. For this example, therefore, the microstrip element center-to-center spacing is only 0.544 wavelengths or 7.78 inches. This gives an effective element edge-to-edge spacing of 0.272 wavelengths or 3.89 inches, which achieves about 28.5 dB of lobe suppression. The actual microstrip patch diameter is about 0.346 wavelengths or 4.95 inches, which give a maximum overall dimension of 36.1 inches for the microstrip phased array. A dielectric constant of about 2.86 is proposed for the substrate material.

Most microstrip radiating elements are intended for broadside radiation and little appears to have been done on wide angle radiators. The microstrip element must be chosen carefully, therefore, to be sure that it has good wide angle coverage and a good axial ratio at wide angles. A suitable choice appears to be that of Kerr⁽¹⁾, which is shown in Figure 4.6-17.

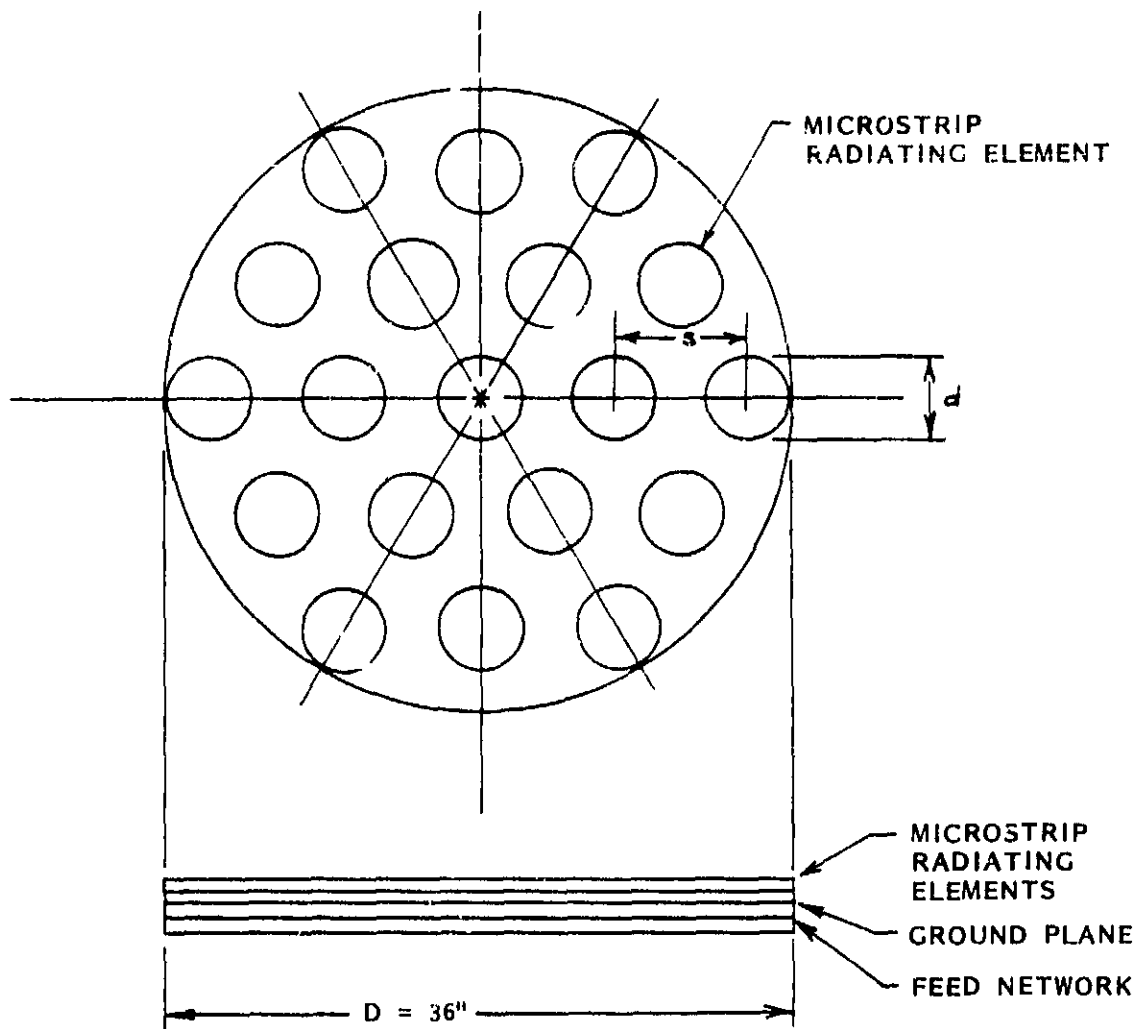

Figure 4.6-16. Microstrip Antenna Concept for Electronic Steering

The six percent bandwidth between the transmit and receive bands for the mobile vehicle application must also be considered in selecting a microstrip element. A stacked dual-disk microstrip element like that of Long and Walton⁽¹⁾ is one approach to that problem. This element is illustrated in Figure 4.6-17b.

Step quantization in phase between opposite edges of the microstrip elements of the array will cause some degradation in the elevation pattern. With an effective element edge-to-edge spacing of only 0.272 wavelength, this quantization phase error is only about $\pm 38.8^\circ$, however, and the triangular element arrangement further reduces its effect.

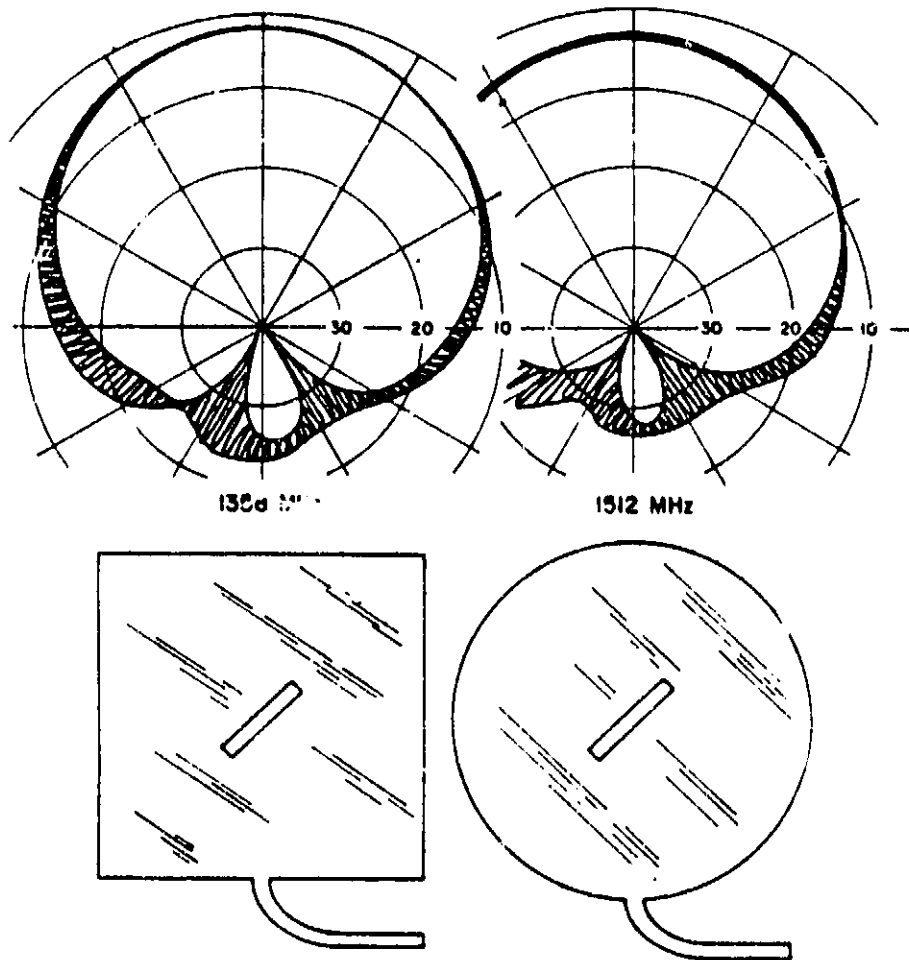

Figure 4.6-17(a). Microstrip Elements, Element Pattern

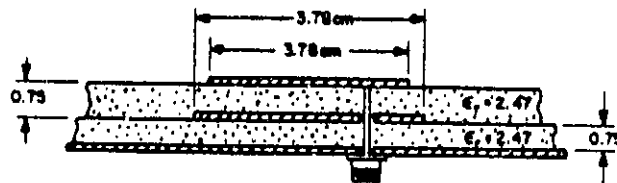

Figure 4.6-17(b). Microstrip Elements, "Sandwich" Construction

The feed network for a microstrip phased array is shown in Figure 4.6-18. The 19-way power divider requires several unequal power splits and also should include provisions for symmetrical amplitude taper radially across the array. The PIN diode phase shifters need not be more than four bit devices. Standard printed circuit board techniques and low cost computer diodes can be used for construction of the phase shifters and the power divider boards, provided that adequate care is given to tolerances to maintain the required impedances.

The azimuth beamwidth of this array is about 30° about both the cardinal and intercardinal planes. Since these planes are spaced 30° apart in azimuth, the array can be steered in 12 azimuthal steps by using only two sets of beam steering commands that are alternated and indexed every 30° . For finer azimuthal beam control, two additional sets of beam steering commands can be added that point the beam midway between the cardinal and intercardinal planes, thus 24 azimuthal steps of 15° each steers the beam in approximately one-half beamwidth steps.

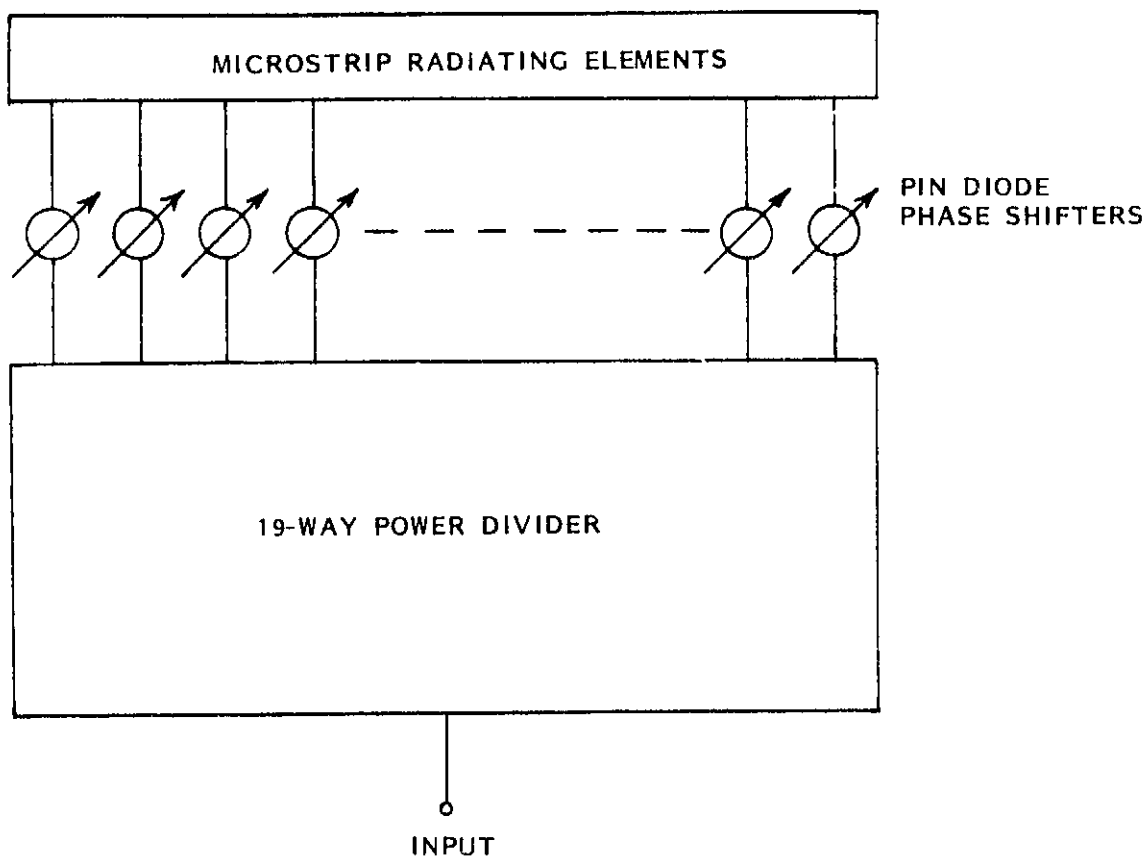

Figure 4.6-18. Beam Forming Network of Phased Array

An alternative concept is to place four, five, or six microstrip phased arrays in a pyramidal configuration. Each array is about 21 inches high by about 10, 13, or 16 inches wide and is tilted back about 37.5° from vertical to point the elevation beam for 45° coverage. This arrangement requires no phase shifters. The individual arrays form fixed beams, and beam switching can be employed with a multi-port diode switch. This configuration is about 17 inches high but occupies a three to four foot square base area, thus it is not considered a very attractive alternative.

4.6.2.6 Pedestrian Antenna Concept

The pedestrian (mobile) antenna must of necessity be simpler and lighter and have acceptably small linear dimensions, thus some compromises in performance may be desirable for the sake of convenience and portability. Several antenna types are described.

One antenna meeting these requirements is the drooping dipole antenna and cup previously described for the so-called fixed antenna. This antenna has good beam shaping possibilities and good circularity and the cup arrangement eliminates the need for an extensive ground plane. A photograph of an S-Band version of this antenna was given in Figure 4.6-12 and an outline sketch in Figure 4.6-13. For light weight the antenna elements can be metallized plastic rods and the cup a metallized foam cylinder, the entire unit encapsulated in a surface hardened foam. It can be projected above the users head by a collapsible mast attached to a backpack or belt-fastened or hand carried radio using a flexible coaxial cable. For good performance the antenna only has to be approximately vertical. Higher gain can be obtained by narrowing the beamwidth slightly (two-satellite operation may not be desirable) or a double stack array of drooping dipole antennas can be used.

A second antenna is a "Wheeler" linear array antenna developed by GE for use at L-Band for an LMSS experiment with ATS-6. A photograph of the L-Band antenna is given in Figure 4.6-19.

The antenna consists of seven equal length sections foreshortened to provide a 14° upward beam tilt from broadside. The top section is shorted to resonate the antenna. Peak gain measured was 4.3 dBi (linearly polarized), dimensions are indicated in Figure 4.6-20 (for the 1.5-1.5 GHz antenna). This antenna is approximately four feet long at UHF; presumably lightweight metallized plastic

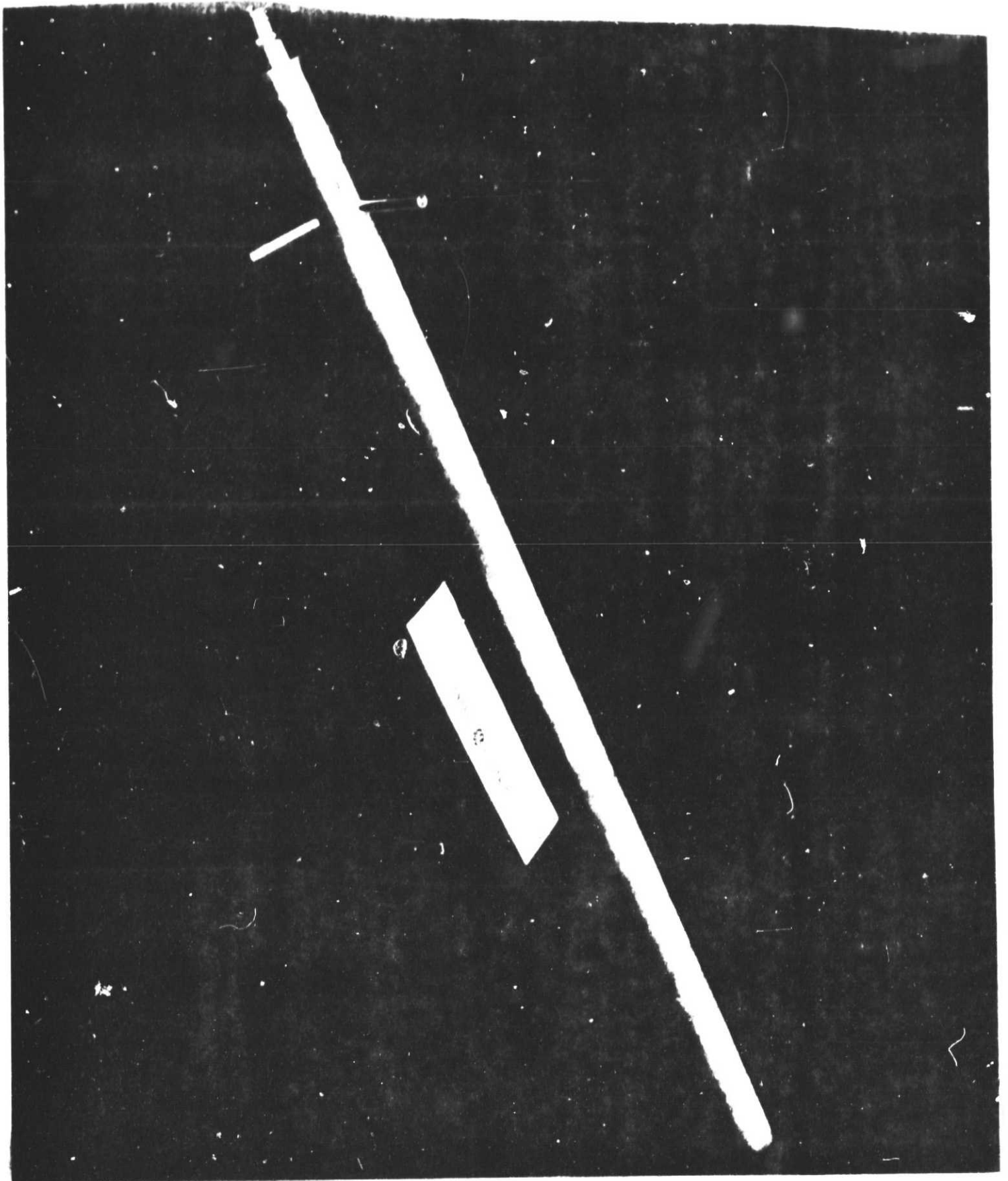

Figure 4.6-19. Wheeler Type Linear Array Antenna (Linearly Polarized)

cylinders can be used to reduce weight. It is not likely to be collapsible. Since this antenna is linearly polarized there will be a 3 dB loss in gain. Convenience is judged to be not as great as with the drooping dipole antenna and the linear array cost will be more also. The principle virtue of this antenna over a simple monopole is its ability to reject ground skip because of the upward looking beam (the monopole gain is about 2 dB less).

A third antenna type can consist of either a short axial mode helix or short crossed yagi antenna. Both have been described previously, however both are light weight, low cost high performance antennas with good circularity and thus are easily portable. Both can be encased in a surface hardened foam. Since the gain is significant the antennas must be pointed, consequently these antennas are not as convenient as those previously described. Pointing involves turning the antenna mast in the azimuthal direction corresponding to the satellite. A concept of this antenna, mounted on a mast is depicted in Figures 4.6-21.

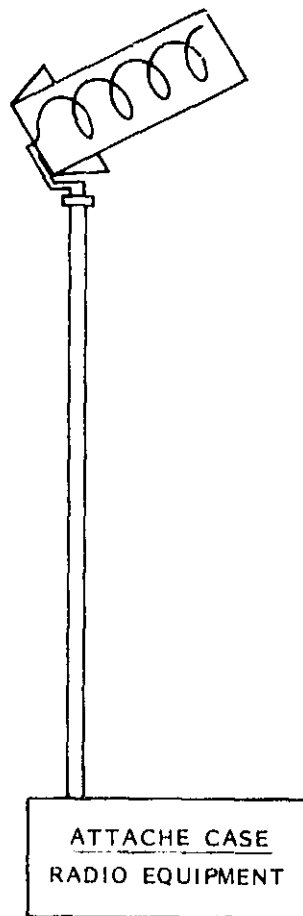

Figure 4.6-21. Pedestrian High Gain Antenna

The supporting stalk can be telescoped for greater convenience and a flexible coax is used for connection to the radio. The antenna is used in situations where the user is not overly inconvenienced by the requirement for "rough steering". Such situations may pertain at construction sites, oil wells etc. A four turn helix with a 12.5° pitch angle provides an on axis gain of about 11 dBi with a corresponding beamwidth of 55° . Overall dimensions are approximately five inches by nine inches for the helix plus about a nine inch diameter ground plane. Antenna noise is somewhat higher than for the mechanically steered antenna previously described, approximately 70 to 80⁰K is anticipated.

A final antenna to consider is a quarter wave monopole. Its gain is -1 db referred to a circularly polarized antenna. Compared to the drooping dipole antenna the difference in gain is not that significant. However a simple monopole will encounter severe fading due to ground reflection - as is encountered in terrestrial systems. In the latter situation however, the combination of short range and relatively high power enables the fading to be "overpowered" e.g., 20 to 30 dB of extra power is provided to overcome the fade depths. This extra power cannot be provided by satellite except at great cost.

It is judged therefore that circularly polarized antennas with some method for ground isolation (ground multipath isolation) such as the drooping dipole and "cup" are best suited to a pedestrian situation.

4.6.3 MOBILE RADIO COSTS

4.6.3.1 Introduction

Four generic services have been defined, cellular-compatible radio telephone, "stand-alone" radio telephone, dispatch ("stand-alone") and interactive data-position location ("stand-alone"). Actually there are a great many more possibilities which will likely be implemented which are tailored to individual or private network needs. For example, steered or fixed antennas, or simpler pedestrian - compatible antennas may be used, reduced channel capability or fixed tuned transceivers will serve in some situations, and transponders such as might be used for oil well logging, etc. might use

manually steered antenna arrays with gains of 15 to 20 dB. Recognizing that the possible implementations can be very large, typical costs are provided for only the few generic services and for the corresponding radios. Salient characteristics of these radios are described in Table 4.6-5.

Investment costs can be converted into periodic costs, including O&M in order to compare the subscriber's transceiver cost with satellite and gateway charges. In this study, interest is assumed to be at a 10% rate, equipment life 10 years and maintenance cost 5% per year.

4.6.3.2 Transceiver Costs

The design of a transceiver such as a cellular transceiver for low production cost takes two to five years preparation and \$5M to \$10M dollars to accomplish. For transceivers selling in the range of \$1000 to \$2000 the prorated design cost is small for production over 100,000 units. The satellite system transceivers for dial up voice and data - either cellular compatible or stand alone are similar to those of the terrestrial system in almost every detail except for the antenna and for the always-available common signalling channel. The production cost of the (satellite) mobile fixed antenna is comparable to a terrestrial antenna (which is not necessarily a simple "whip") while the steered antenna might cost as much as \$100 extra. An approximate cost allocation is given by;

| | |
|-----------------|-------------|
| power amplifier | 21% |
| synthesizer | 10 |
| handset | 21 |
| antenna | 8 |
| controller | 10 |
| receiver | 10 |
| audio | 5 |
| packaging | 15 |
| | <u>100%</u> |

It is apparent that, except for the steered antenna the satellite system mobile transceiver should be close in price to its terrestrial counterparts.

The interactive data position location transceiver with fixed antenna, is fixed tuned and considerably simpler, and is expected to be produced in considerable volume - perhaps millions, if not tens of millions of units. Its cost should be correspondingly less, and of course, its development cost is not significant compared to the production cost.

Figure 4.6-22 shows the relationship between a user's investment cost for equipment, including installation, vs. monthly cost (to compare with monthly charges described elsewhere), and equivalent cost per call minute, assuming subscriber representative calling rates and a peak factor of 2:1. Also indicated in Figure 4.6-22 are ranges of investment cost representative of the generic radios. Thus, both cellular compatible and "stand-alone radio telephone radios with full signalling and switching capability will be sold in the range of \$800 to \$1500 resulting in monthly costs of \$17 to \$26 per month or call minute charges of 2.7¢ per minute to 5¢ per minute, (.03 erlangs). Of course, the user "pays" for his radio only during the time he uses it, e.g. his call minute rate times his average use (erlangs) is equal to the monthly cost. It is apparent that his radio costs are small compared to his satellite charges. For example a more sophisticated antenna, such as a steered antenna, estimated to cost \$100 more than the simple fixed antenna substantially reduces his satellite charges, yet costs only \$1.70 per month or 0.28 cents per minute. The more sophisticated antenna is clearly worthwhile.

Dispatch systems are less expensive, not all the signalling and switching is believed to be necessary. Cost per month is approximately \$17 per month or approximately 8.1¢ per minute, comparable to the space segment charges previously discussed. However, cost of a more sophisticated antenna is still a bargain, particularly if the mobiles operates in areas of substantial building multipath and man made noise. Therefore, it appears that relatively sophisticated antennas such as the steerable ones described previously, are important to LMSS.

Finally, it is believed that the simple interactive data-position location transceivers, fixed tuned, and with simple, fixed antennas will cost between \$100 and \$200 with simple readouts. Monthly costs are in the range of \$2.23 to \$4.34 or 9.9 cents per minute to 21 cents per minute at .001 erlangs peak, or roughly 2000 users per channel. Of course, mobiles for this service are expected to transmit less than a second per day so that the monthly charge is the best measure of value. It is clear in this case that radio costs are important and simple fixed antennas more desirable.

Table 4.6-5. Mobile Radio Characteristics

| SERVICE CLASSIFICATION | ANTENNA TYPE | FEATURES | PROBLEMS |
|--|---|--|---|
| CELLULAR COMPATIBLE RADIO TELEPHONE (VOICE OR WB DATA) | FIXED ANT (3 dBi) | SATELLITE ANTENNA (SWITCHED IN) LOW NOISE PREAMP AT ANTENNA 15 kHz COMPANDED FM COMPATIBLE SIGNALLING FORMAT (FSK) SAME SYNTHESIZER AS CELLULAR | VOX OPERATION ADDITIONAL HPA POWER LEVELS SINGLE SIGNALLING BURSTS TROUBLESOME PERFORMANCE IN URBAN AREAS |
| STANDALONE RADIO TELEPHONE (VOICE OR WB DATA) | STEERED (+10 dBi) ELECTRONIC OR MECHANICAL | LOW NOISE PREAMP AT ANTENNA 4 kHz COMPANDED SSB PSK SIGNALLING FORMAT SYNTHESIZER SATELLITE FREQ LOCK (ALWAYS AVAIL- ABLE COMMON SIGNALLING CHOICE) STEP TRACK STEERING | AGC FROM COMMON SIGNALLING CHANNEL AFC FROM IN BAND TONE MODULATION TRANSMITTERS MUST ALLOW FOR PEAK ENVELOPE |
| STANDALONE * DISPATCH (VOICE OR WB DATA) | AS ABOVE | AS ABOVE | AS ABOVE |
| STANDALONE INTER- ACTIVE DATA/ POSITION LOCATION | FIXED ANTENNA (+ 3 dBi) | SWITCHABLE POLARITY LOW NOISE PREAMP AT ANTENNA 2 kHz (OR MULTIPLE); CHANNEL SLOT ** P K, CONVOLUTIONAL CODER FIXED-TUNED (SATELLITE FREQUENCY LOCK) ** TRANSMITTER ON ONLY FOR TRANS- MISSION (ALARM OR INTERROGATION) | VERY LOW COST CHANNEL ISOLATION (MAY REQUIRE 2 CHANNELS) BATTERY OPERATION (LOW POWER) |

* MULTIPLE BEAM OPERATION REQUIRES DIALING; SIMPLEX OPERATION IS USABLE ONLY WITHIN BEAM

** WIDER CHANNEL SLOT, E.G., 16 kHz ELIMINATES SATELLITE FREQUENCY LOCK

C

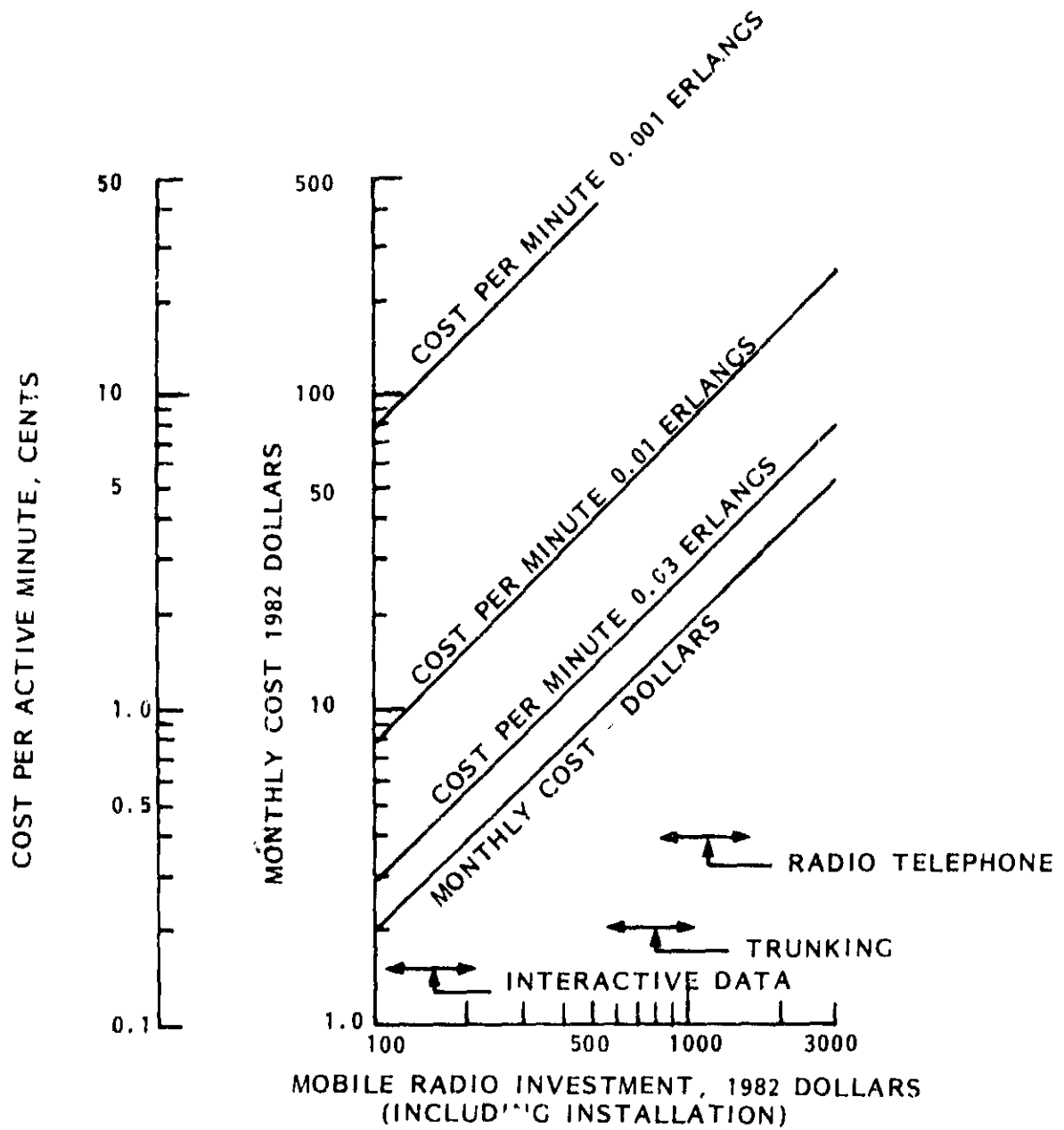

Figure 4.6-22. Mobile Radio Cost Characteristics

REFERENCES

1. BSTJ January 1979, Pages 123-143.
2. NAS 5-20034, HTS-5 Trilateral Support
3. IEEE Transaction AP-S, Volume AP-29, January 1981 (issue devoted entirely to microstrip antennas)

4.7 TOTAL SUBSCRIBER CHARGES

4.7 TOTAL SUBSCRIBER CHARGES

Total subscriber charges, consisting of space system, gateway and mobile radio, can be described for a representative situation, based on information presented previously. The representative situation chosen is based on the likely traffic projection, second generation system, e.g. characteristic of a mature LMSS operating in the years 1993 to 2000 AD.

The system, with two operating satellites and one spare, is capable of 80,000 equivalent 4 KHz trunks, provides 71 beams per satellite and represents a total investment of 1470 millions of (1982) dollars. The investment per trunk and per subscriber are tabulated in Table 4.7-1.

Call minute charges for the system, based on a peak to average factor of 2, beam fill of 1, and bandwidth/power factor of 1, are tabulated in Table 4.7-2.

Space segment charges are typically 5.3 cents per minute, 19.6 cents per minute and 30 cents per minute for 4, 15 and 30 KHz trunks respectively. Somewhat lower values are obtained if the satellite can be "filled" more quickly, and somewhat higher values pertain to 40% return on investment. The charges show the value of narrowband modulation. These call minute charges can be translated into monthly charges for typical subscriber usage, assumed to be .03 erlangs peak for radio telephone subscribers and .01 erlangs peak for trunking subscribers; results are tabulated in Table 4.7-3.

Table 4.7-1. Investment Per Trunk and Investment Per Subscriber, Total Investment = \$1470M

| TRUNK TYPE | SERVICE | INVESTMENT PER TRUNK | INVESTMENT PER SUBSCRIBER * |
|------------|-----------------|----------------------|-----------------------------|
| 30 kHz | RADIO TELEPHONE | \$ 137,800 | \$ 4546 |
| 15 kHz | RADIO TELEPHONE | \$ 69,000 | \$ 2273 |
| 4 kHz | RADIO TELEPHONE | \$ 18,375 | \$ 606 |
| 4 kHz | TRUNKING | \$ 18,375 | \$ 184 |

* RADIO TELEPHONE = 0.03 ERLANGS PEAK, TRUNKING = 0.01 ERLANGS PEAK

Table 4.7-2. Call Minute Charges

| TRUNK TYPE | RETURN ON INVESTMENT = 20% | | RETURN ON INVESTMENT = 40% | |
|---------------------|-------------------------------------|------------------|-------------------------------------|------------------|
| | CHARGE FOR LIKELY MARKET PROJECTION | ASYMPTOTIC VALUE | CHARGE FOR LIKELY MARKET PROJECTION | ASYMPTOTIC VALUE |
| 4 kHz | 5.3 ¢/MIN | 3.2 | 9.6 | 5.6 |
| 15 kHz ^A | 19.6 ¢/MIN | 12.0 | 35.7 | 20.7 |
| 30 kHz | 43.2 ¢/MIN | 26.4 | 78.7 | 45.7 |

Gateway costs, based on a quantity of 1000, which is believed to be conservative, are displayed in Table 4.7-4, as a function of gateway capacity. One erlang corresponds approximately to 33 radio telephone subscribers or 100 dispatch subscribers, so that the subscriber base need not be large in order to attain gateway charges that are small compared to the space system charge. A capacity of one erlang results in a charge of 2.5¢ per minute.

Table 4.7-3. Monthly Charges for Typical Subscribers

| TRUNK TYPE | SERVICE | RETURN ON INVESTMENT = 20 % | RETURN ON INVESTMENT = 40 % |
|------------|-------------------------------|-----------------------------|-----------------------------|
| 4 kHz | TRUNKING | \$ 11.60 | \$ 21.00 |
| 4 kHz | RADIO TELEPHONE (STAND-ALONE) | \$ 29.93 | \$ 54.18 |
| 15 kHz | RADIO TELEPHONE (COMPATIBLE) | \$ 128.70 | \$ 234.45 |
| 30 kHz | RADIO TELEPHONE (COMPATIBLE) | \$ 283.70 | \$ 516.80 |

Table 4.7-4. Typical Gateway Charges

| GATEWAY TRAFFIC ERLANGS | CALL-MINUTE CHARGE CENTS PER MINUTE |
|----------------------------|---|
| 0.1 | 17 |
| 0.5 | 5 |
| 1.0 | 2 |
| 1.5 | 0.9 |

Finally, subscriber radio costs are tabulated in Table 4.7-5, in terms of monthly charges based on 10% interest, 10 year payback and 5% maintenance.

All three charges, space, gateway and mobile radio, can be added together to obtain total typical charges for the LMSS service. These charges are given in Table 4.7-6 for the case of 20% return on investment and a gateway peak capacity of one erlang.

Table 4.7-5. Equivalent Transceiver Charges

| | INSTALLED COST | MONTHLY CHARGE | MINUTE CHARGE |
|------------------|-------------------|-------------------|------------------|
| RADIO TELEPHONE | \$ 1500 | \$ 26 | 4 CENTS |
| TRUNKING | \$ 1000 | \$ 18 | 8 CENTS |
| INTERACTIVE DATA | \$ 100 | \$ 2 | 8 CENTS |

Table 4.7-6. Typical Total Subscriber Charges (Space Segment, Gateway and Mobile Radio)

| TRUNK TYPE | SERVICE | MONTHLY CHARGE DOLLARS | MINUTE CHARGE CENTS |
|------------|-----------------|------------------------|---------------------|
| 4 kHz | TRUNKING | 34 | 15.3 |
| 4 kHz | RADIO TELEPHONE | 69 | 11.3 |
| 15 kHz | RADIO TELEPHONE | 168 | 25.6 |
| 30 kHz | RADIO TELEPHONE | 323 | 49.2 |

The narrowband (4KHz) radio telephone and trunking services are attractive compared to present usage, especially considering that the charges are distance invariant. The 15 KHz cellular compatible radio telephone service also is comparable to expected cellular charges. Both the 15 KHz and 30 KHz radio telephone services are not expected to serve urban areas where cellular systems already exist but to serve the cellular customer by providing roaming, paging, wideband, and long distance services. In this case the toll charges are favorable compared to long distance TELCO charges, and the subscriber activity should therefore be considerably less than .03 erlangs (he uses the satellite service only when the terrestrial service is not usable). It is also apparent that the satellite system can provide a new radio telephone service which is not compatible with cellular but which can provide attractively priced services everywhere except in the downtown sections of the largest cities. The two services are "mirror images" of each other - the cellular works well in urban locations, the satellite works well in rural - suburban locations.

Eventually, the radio telephone mobile equipment might be designed to optimize both terrestrial and satellite system parameters simultaneously, e.g. 30 KHz FM and compandored SSB. Perhaps, to conserve bandwidth in order to provide expansion beyond the capacities now foreseen the terrestrial system might eventually adapt compandored single sideband, or some comparable technique such as (digital) linear predictive encoding. A truly versatile, high capacity national radio telephone system could then emerge.

4.8 IMPLEMENTATION SCENARIO

4.8 IMPLEMENTATION SCENARIO

4.8.1 RECOMMENDED APPROACH

The difficulty in commercially implementing a land mobile satellite system is a compounding of four factors:

1. The technology of a multiple beam LMSS with its large deployable antenna and unique spacecraft bus increases the risk of failure.
2. While the markets an LMSS would serve are believed to be large, there is no assurance or experience to prove that subscribers would flock to the system in sufficient numbers, and early enough in order to generate an adequate investor's return; another factor to be weighed is the ability of the mobile equipment manufacturers (and to a lesser extent the gateway manufacturers), to provide sufficient quantities of equipment even if the market itself is otherwise willing.
3. The FCC has not allocated any bandwidth to a LMSS, a situation that casts a veil of uncertainty over any potential commercial endeavor; a corollary is that the FCC is not likely to allocate precious UHF bandwidth to an LMSS unless it has reasonable assurances that such a system is in the public interest and that it will go forward.
4. A final most important consideration is the truly enormous investment required before both the market and the technology can be "tested". The investment for the plan suggested herein approaches one billion 1982 dollars.

The above considerations suggest a more evolutionary approach with a smaller satellite in order to obtain favorable FCC action and FCC authorization, establish the commercial entity and, establish the market characteristics. Previous studies have indicated the difficulties of the approach from the point of view of commercial viability. However LMSS proceeds, the gap that must be bridged, sooner or later, is the construction and launch of a large, high capacity multiple beam satellite. NASA can play a key role in the accomplishment of a mature LMSS; one plan (there are many), suggested herein is a cooperative venture between NASA and a commercial entity to accomplish the high capacity U.S. land mobile satellite system believed to be needed in the 1990-2000 time frame.

It is assumed that a satellite similar to Concept C2 is desired. This satellite has 31 UHF beams, 1 S-Band (or Ku Band) beam for the fixed service, has a beginning of life mass in synchronous orbit, of 3809 lbs (3850 lbs if Ku-Band is used), generates 1800 watts at the end of life (approximately 2200

watts if Ku Band is used) and requires a UHF power amplifier RF capability of over 12 watts. This satellite generates approximately $31 \times 0.9 \times 2.5$ MHz = 69.75 MHz of useful bandwidth at a fill factor of one (7.75 times the capacity of a simple single beam satellite). No on-board switching is used. The mobile radio must generate 2.6 watts of power with a 10 dBi steerable antenna or 12.9 watts with a fixed antenna, for a 15 KHz voice channel (FM). The gateway power amplifier power is .44 watts per carrier with a three meter antenna, plus about 10 dB for uplink power diversity. Satellite fixed services power at Ku-Band is 240 watts. Its antenna diameter is approximately 100 feet (33 meters), three times the diameter of NASA's ATS-6 satellite. An antenna significantly larger than 10 meters is required; a ten meter antenna with a beamwidth 2.6 degrees is not sufficient to obtain frequency reuse via spot beams. A 10 beam system, (plus off shore beams), with a 55 foot aperture, 1.5 degree beamwidth and a 4:1 frequency segmentation generates only 2.5 times the bandwidth of a simple single beam satellite, (fill factor of one). While this represents an advance in the state-of-the-art with regard to ATS-6, the increase in capacity (over a single beam system) is not very significant. Consequently, it was concluded that a larger antenna but roughly in the same technology class, is a better choice.

It should be noted that the capability of this satellite cannot meet the requirements of the "likely" market projection. However, in the absence of an LMSS to serve and stimulate that market, it is not reasonable to conclude that projection is valid.

Finally, the high power version (Concept C2 or performance +10 db better than the nominal case), was selected because the cost implication was minor, fixed antennas provide excellent performance and steerable antennas will work well in most urban locations not excessively troubled by "shadowing".

The concept selected, of course, is a compromise to limit investment and minimize technology risk, yet provide a significant advance in the state of the art of high capacity multiple beam land mobile satellites.

The recommended implementation is a cooperative effort between NASA, to develop the technology, and a commercial entity to use the technology in the public interest, and to provide an adequate attractive return to its investors to encourage continuing evolution of the services and the technology. Of

course, the suggested scenario is only one of many, but it suggests a generic approach based on cooperation between NASA and a commercial entity providing operational services. The split in tasks depends on when the commercial entity is formed and is viable, and therefore two possibilities are considered. Basically, NASA continues the development of technology to its maturity but depending on the formation of the commercial entity, NASA may share or not share the system development costs with the commercial entity. In addition, NASA shares the cost of the first satellite - used initially for test and demonstration by NASA and later for revenue producing services by the commercial entity, requiring a transfer of ownership, say, at the life midpoint. The commercial entity also launches other satellites of similar design, as needed for service. Gateways and mobile equipment are manufactured by industry and are owned by system operators (or subscribers), but not by NASA or the commercial entity.

4.8.2 DEVELOPMENT SCENARIO

A schedule of events is depicted in Figure 4.8-1. The direct "path" to system implementation includes a competitive "Requirements Definition Study" (1983-1984) sponsored by NASA and a competitive "Phase "C" - n Study" (1985-1986) sponsored by NASA leading to the selection of a manufacturer for satellite development beginning in 1987. If the commercial entity is formed by 1987 (Scenario A), the development cost can be shared; perhaps the commercial entity is responsible for the transponders and feed design and NASA is responsible for the spacecraft bus and antenna. If the commercial entity is not formed until later (Scenario B), then NASA is responsible for the entire satellite development. In either case, an early launch of satellite "E" (for experimental) enables 2.5 years (more or less) for experimentation and demonstration - principally to allow market aggregation, system test, and for disposition of gateways and satellite compatible mobile radios. At the end of 3.5 years, satellite ownership passes to the commercial entity. Figure 4.8-1 also identifies year-end 1984 as the assumed date for FCC frequency allocation and authorization to proceed. Figure 4.8-1 also depicts other development programs (proof of concept or POC), consisting of mobile antenna development, satellite linear amplifier development and satellite antenna feed development. A follow-on development program to provide field tests and demonstrations of mobile test vehicles with antennas is needed. Using antenna types similar to those previously developed, such as fixed and steerable

antennas, various tests of shadowing, multipath fading (ground "skip" and building skip"), thermal and man-made noise and doppler, can be made to evaluate antenna and modulation (companion action, SSB, etc). technology. Large aperture development, shown by the dashed lines in Figure 4.8-1 is already on-going and the funding is assumed not to be part of LMSS.

Two other development programs are important. One is the development of a low cost gateway, vitally needed to avoid TELCO charges which could render LMSS uneconomic or unattractive (a low cost SCPC terminal also may have other applications in the fixed satellite service). The other is a "PUC" program for mobile radios to stimulate a timely interest by the mobile radio equipment suppliers in satellite compatible radios as a prelude to their commitments to develop and sell the equipment later.

Figure 4.8-1 allocates time for radio and gateway equipment manufacturers to develop and market their wares; of course, this is done at their expense, perhaps by means of business arrangements with major users.

The NOC/SOC, a state of the art facility requiring no advanced technology is built and tested as depicted in Figure 4.8-1.

The stage is now set, at the beginning 1991, to launch the first satellite ("E"), operate the system via the NOC/SOC, and distribute gateways and mobiles for a pre-operational 2.5 year period. This period also serves as a market aggregation period which ends with the introduction into service of the "F1" operational satellite. Experiments and demonstrations are then transferred from "E" to "F1" for revenue producing service. Upon completion of its experimental program, E becomes a second operational satellite. At the end of its life, 4.5 year later, it is replaced by "F2".

The scenario ends in the year 2000; presumably the system can either be continued by the launch of another satellite to replace F1, (a response to a stagnant market) or a new generation higher capacity satellite can be introduced in response to a growing market and F2 continued in service as a spare. In this case F2 has salvage value with regard to the first 7 year operational period.

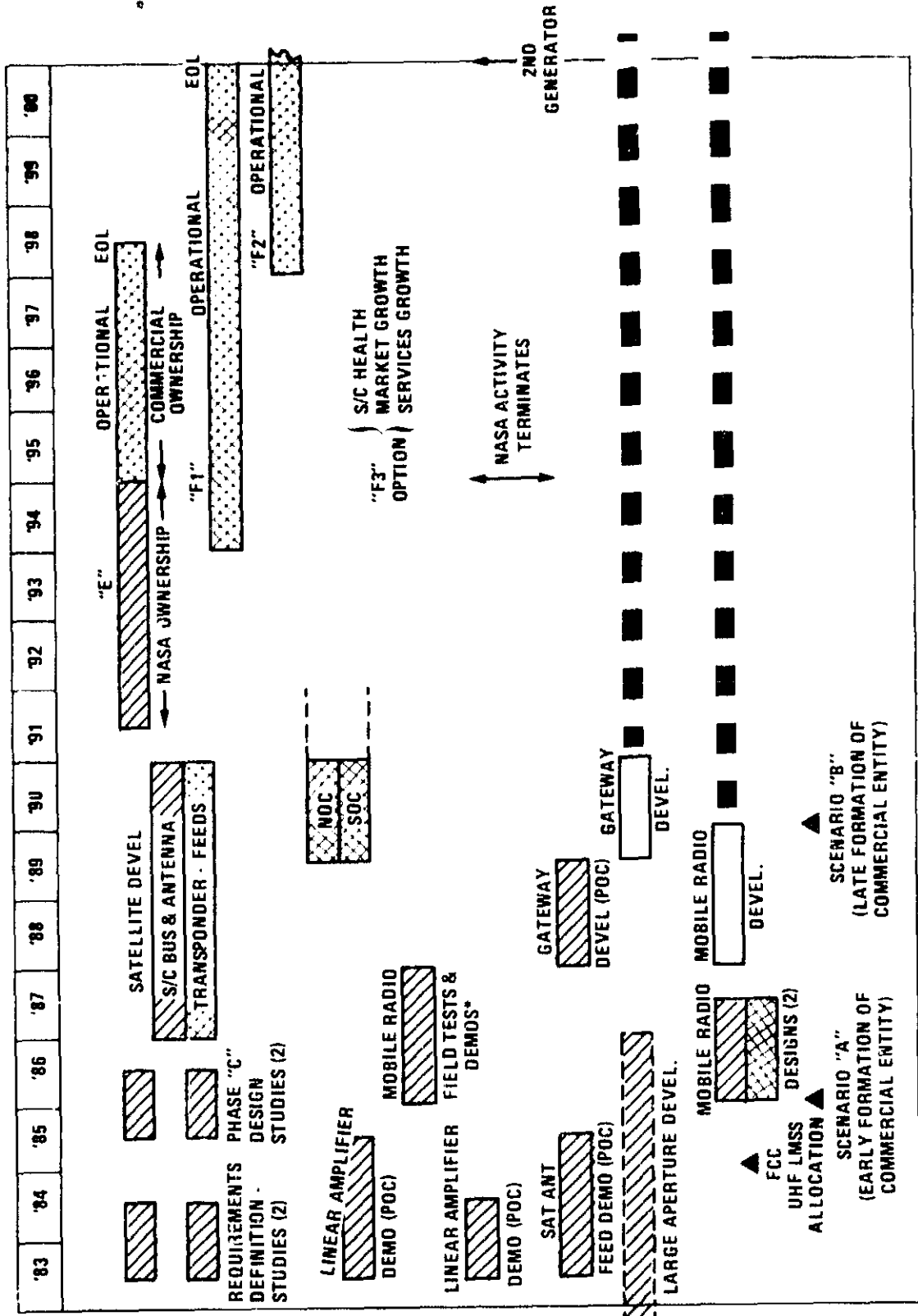

*NO PRECURSOR PROGRAM
 *TWO COMMERCIAL SCENARIOS

*M-SAT, ATS-3, IN MARSAT

Figure 4.8-1. LMSS Development Scenario

Table 4.8-1 is an investment allocation between NASA and the commercial entity for the two scenarios, based on the SAMSU model costs computed for Concept C2. A perusal of the table indicates that the commercial entity has little to do with the technology development at the program beginning, can share in the development cost only if it is formed in time, but certainly must assume the burden for the revenue producing system elements.

For Scenario A (the early appearance of the commercial entity), Table 4.8-2 describes total NASA investments (not counting personnel and overhead) and Table 4.8-3 describes the total commercial entity investments (also not counting personnel and overhead, etc). The peak NASA investment is \$61.5M and the total is \$245M. The commercial entity invests heavily somewhat later and accumulates a total investment of \$670.5M.

If the commercial entity appears later, then Scenario B pertains and Table 4.8-4 describes the NASA investment, which is considerably higher at the peak and in total, and Table 4.8-5 describes the corresponding commercial entity investment.

4.8.3 INSTITUTIONAL AND REGULATORY ASSUMPTIONS

The FCC actions on LMSS are crucial to its successful implementation and viable operation. Sufficient bandwidth must be allocated to enable a meaningful system. This study assumes 10 MHz. If only half the bandwidth is allocated, LMSS loses approximately half its income, or satellite complexity, for a given capacity, is substantially increased (not counting diplexing losses, twice the number of beams are needed). LMSS economic viability is seriously threatened, if not destroyed. In addition, this bandwidth should be continuous to facilitate the 4:1 frequency segmentation, the minimum segmentation believed necessary to obtain reasonable sidelobe isolation in a multiple beam system. If the beamwidth is not continuous, it may not be possible for the segmentation to result in an efficient system.

The selection of uplink and downlink bands also is critical with regard to LMSS isolation vis a vis the cellular and SMR systems, and regulations can be imposed on radiation specifications and interference situations which can severely limit LMSS operation near the terrestrial facilities. All these issues require reasonably favorable and timely FCC action as well as additional detailed study. To achieve the implementation plan described

Table 4.8-1. Cost Allocation, Concept C2

| | SCENARIO A | | SCENARIO B | |
|--|------------------|-----------------|------------------|---------------|
| | NASA | COMMERCIAL | NASA | COMMERCIAL |
| REQUIREMENTS DEFINITION | | | | |
| STUDIES (2) | 2 M | - | 2M | |
| PHASE C DESIGN (2) | 4 M | - | 4 M | |
| MOBILE ANTENNA DEVEL (POC) | 1 | -- | 1 | -- |
| LINEAR AMPLIFIER DEMO (POC) | 1 | -- | 1 | -- |
| SATELLITE ANTENNA FEED DEMO (POC) | 2 | -- | 2 | -- |
| MOBILE RADIO FIELD TESTS/DEMOS | 2 | -- | 2 | -- |
| MOBILE RADIO DESIGNS | 1 | 1 | 2 | -- |
| LARGE APERTURE DEVELOPMENT* | N/A | -- | N/A | -- |
| GATEWAY DEVEL. (POC) | 2 | -- | 2 | -- |
| SATELLITE DEVELOPMENT | | | | |
| S/C BUS/ANTENNA | 126.8 | -- | 126.8 | -- |
| TRANSPONDERS | -- | 139.5 | 139.5 | -- |
| LAUNCH VEHICLE PROCUREMENT | | | | |
| E | 29 | 29 | 29 | 29 |
| F1 | -- | 58 | -- | 58 |
| F2 | -- | 58 | -- | 58 |
| F3 | -- | (58) | -- | (58) |
| NOC/SOC | -- | 15 | 7.5 | 7.5 |
| SATELLITE & LAUNCH & INSURANCE & MISC. | | | | |
| E | 74.1 | 74.05 | 74.05 | 74.05 |
| F1 | | 148.1 | | 148.1 |
| F2 | | 148.1 | | 148.1 |
| F3 | | (148.1) | | (148.1) |
| | \$ 244.9 | \$670.8 (73.2%) | \$392.9 | \$522.8 (57%) |
| TOTAL | \$915.6 M | | \$915.6 M | |

* ASSUMED TO BE ALREADY FUNDED BY NASA/DOD

Table 4.8-2. NASA Investment Schedule, Scenario "A"

| | 1983 | 1984 | 1985 | 1986 | 1987 | 1988 | 1989 | 1990 |
|---|---------|---------|---------|---------|----------|----------|----------|----------|
| REQUIREMENTS DEFINITION STUDIES (2) | 1 | 1 | | | | | | |
| PHASE "C" DESIGN STUDIES (2) | | | 2 | 2 | | | | |
| MOBILE ANTENNA DEVEL. (POC) | 0.25 | 0.5 | 0.25 | | | | | |
| LINEAR AMPLIFIER DEMO (POC) | 0.5 | 0.5 | | | | | | |
| SATELLITE ANTENNA FEED DEMO (POC) | 0.5 | 1 | 0.5 | | | | | |
| MOBILE RADIO FIELD TESTS/DEMOS | | | | 1 | 1 | | | |
| GATEWAY DEVELOPMENT (POC) | | | | | | 1.3 | 0.7 | |
| MOBILE RADIO DESIGNS | | | | | 0.7 | 0.3 | | |
| SATELLITE DEVELOPMENT (S/C BUS & ANTENNA) | | | | | 31.7 | 31.7 | 31.7 | 31.7 |
| LAUNCH VEHICLE PROCUREMENT | | | | | | 9.7 | 9.7 | 9.7 |
| SATELLITE COST ("E") * | | | | | 18.5 | 18.5 | 18.5 | 18.5 |
| TOTAL, PER ANNUM | \$2.3 M | \$3.0 M | \$2.8 M | \$3 M | \$51.9 M | \$61.5 M | \$60.6 M | \$59.9 M |
| TOTAL, CUMULATIVE | | \$5.3 M | \$8.1 M | \$11.1M | \$63.0 M | \$124.5M | \$185.1M | \$245.0M |

Table 4.8-3. Commercial Investment Schedule Scenario "A"

| | 1987 | 1988 | 1989 | 1990 | 1991 | 1992 | 1993 | 1994 | 1995 | 1996 | 1997 |
|----------------------------|---------|---------|----------|----------|----------|----------|----------|----------|----------|----------|----------|
| MOBILE RADIO DESIGNS | 0.7 | 0.3 | | | | | | | | | |
| SATELLITE DEVELOPMENT | | | | 34.9 | 34.9 | 34.9 | 34.9 | | | | |
| LAUNCH VEHICLE PROCUREMENT | | | | | | | | | | | |
| E | 9.7 | 9.7 | 9.7 | 9.7 | | | | | | | |
| 1 | | | 19.3 | 19.3 | 19.3 | | | | | | |
| F2 | | | | | | | | 19.3 | 19.3 | 19.3 | 19.3 |
| SATELLITES | | | | | | | | | | | |
| E | 18.5 | 18.5 | 18.5 | 18.5 | | | | | | | |
| F1 | | | | 37.0 | 37.0 | 37.0 | 37.0 | | | | |
| F2 | | | | | | | | 37 | 37 | 37 | 37 |
| NOC/SOC | | | 5 | 10 | | | | | | | |
| TOTAL, PER ANNUM | \$19.2M | \$28.5M | \$33.2M | \$110.1M | \$ 91.2M | \$ 91.2M | \$ 91.2M | \$ 37 M | \$ 56.3M | \$ 56.3M | \$ 56.3M |
| TOTAL, CUMULATIVE | \$47.7M | \$80.9M | \$282.2M | \$373.4M | \$464.6M | \$501.6M | \$557.9M | \$614.2M | \$670.5M | | |

Table 4.8-4. NASA Investment Schedule, Scenario "B"

| | 1983 | 1984 | 1985 | 1986 | 1987 | 1988 | 1989 | 1990 |
|-------------------------------------|--------|--------|---------|---------|---------|----------|----------|----------|
| REQUIREMENTS DEFINITION STUDIES (2) | 1 | 1 | | | | | | |
| PHASE "C" DESIGN STUDIES (2) | | | 2 | 2 | | | | |
| MOBILE ANTENNA DEVELOPMENT (POC) | 0.25 | 0.5 | 0.25 | | | | | |
| LINEAR AMPLIFIER DEMO (POC) | 0.5 | 0.5 | | | | | | |
| SATELLITE ANTENNA FEED DEMO (POC) | 0.5 | 1 | 0.5 | | | | | |
| MOBILE RADIO FIELD TESTS/DEMOS | | | | 1 | 1 | | | |
| GATEWAY DEVELOPMENT (POC) | | | | | | 1.3 | 0.7 | |
| MOBILE RADIO DESIGNS (2) | | | | 1.3 | 0.7 | | | |
| NOC/SOC | | | | | | | 2.5 | 5 |
| SATELLITE DEVELOPMENT | | | | 66.6 | 66.6 | 66.6 | 66.6 | 66.6 |
| LAUNCH VEHICLE PROCUREMENT | | | | | 9.7 | 9.7 | 9.7 | 9.7 |
| SATELLITE COST ("E") * | | | | 18.5 | 18.5 | 18.5 | 18.5 | 18.5 |
| TOTAL, PER ANNUM | \$2.3M | \$3.0M | \$2.75M | \$ 3 M | \$87.4M | \$ 96.8M | \$ 98.0M | \$ 99.8M |
| TOTAL, CUMULATIVE | | \$5.3M | \$8.1 M | \$11.1M | \$98.5M | \$195.3M | \$293.3M | \$393.1M |

Table 4.8-5. Commercial Investment Schedule, Scenario "8"

| | 1987 | 1988 | 1989 | 1990 | 1991 | 1992 | 1993 | 1994 | 1995 | 1996 | 1997 |
|----------------------------|---------|---------|----------|----------|----------|----------|----------|----------|----------|----------|---------|
| NOC/SOC | | | | | 7.5 | | | | | | |
| LAUNCH VEHICLE PROCUREMENT | | | | | | | | | | | |
| E | | 9.7 | 9.7 | 9.7 | | | | | | | |
| F1 | | | | | 19.3 | 19.3 | 19.3 | | | | |
| F2 | | | | | | | | | 19.3 | 19.3 | 19.3 |
| SATELLITES | | | | | | | | | | | |
| E | 18.5 | 18.5 | 18.5 | 18.5 | | | | | | | |
| F1 | | | | 37.0 | 37.0 | 37.0 | 37.0 | | | | |
| F2 | | | | | | | | 37.0 | 37.0 | 37.0 | 37.0 |
| TOTAL, PER ANNUM | \$18.5M | \$28.2M | \$28.2M | \$65.2M | \$63.8M | \$56.3M | \$56.3M | \$37.0M | \$56.3M | \$56.3M | \$56.3M |
| TOTAL, CUMULATIVE | \$46.7M | \$74.9M | \$140.1M | \$203.9M | \$260.2M | \$316.5M | \$353.5M | \$409.8M | \$466.1M | \$522.4M | |

previously, FCC favorable action should be obtained in 1985, which requires continuing interaction between the FCC and interested parties, including NASA up until that period.

If S-Band is to be used for the fixed link, additional FCC action is needed to allow LMSS fixed links in the 2500-2690 MHz band. Operation in this band is not desirable, however, because of the substantial uplink interference created by ITFS transmitters. Operation at Ku Band for LMSS removes this difficulty, has but a small effect on gateway costs but does require extensive coordination to remove certain interferences caused by other fixed services operations in Ku Band. Reconciliation of these issues at the FCC requires a detailed system design and implementation plan.

Favorable FCC action also can substantially affect commercial interests in LMSS, since it is apparent that a market exists and the technology problems can be overcome by direct NASA participation. However, the formation of a corporation with the investment capability to accomplish the recommended system will be very difficult and probably will take a long time. In the absence of the support such a corporation would give at the FCC, NASA, representing the particular public interests of prospective public, Government and industry users of LMSS (as well as the corporation which provides the operational service) will have to present the case. This includes the public interests of why LMSS is important, the utility of the special services and the technical characteristics necessary to define how LMSS works in its radio environment. Therefore, continued effort at the FCC on all these issues by NASA is a necessary prelude to the success of LMSS in a reasonable time frame.

4.8.4 TECHNOLOGY IMPROVEMENTS

4.8.4.1 Introduction

This section is a compendium of technology that either requires development and demonstration or that is key to the development of a spectrum efficient, cost effective LMSS. Some technology is obvious but nevertheless is included for completeness; other technology has, by virtue of this study, been identified as important. Since detailed, satellite, gateway or mobile radio designs have not been part of the Study, additional problems perhaps as challenging as those to be described can emerge from future system studies and

technology development. It is believed, however, that the present Study has identified almost all those which are keys to the future LMSS. These are listed in the following sections along with an indication where the studies and developments could be performed in the proposed scenario.

4.8.4.2 Space Segment

The deployable offset fed antenna is of course, the dominant feature of the satellite, and much development work and demonstrations have already been accomplished. A principle issue to be dealt with is whether such a system should be deployed in the STS orbit, perhaps with EVA support, or EVA support if needed, and the possibility of antenna retraction and return to earth should problems develop. It is axiomatic that the antenna deployment (specifically what to do if it doesn't) is the key technological problem to be solved, particularly considering the enormous satellite-launch vehicle cost, the uniqueness of this experience in aerospace history and the consequent indemnification problems. The remaining spacecraft problems, while significant, are more tractable. A listing of a space segment technology assessment is given in Table 4.8-6.

4.8.4.3 Gateway

The Ku-Band SCPL earth stations are state of the art and used (and planned to be used), extensively with U.S. Fixed Services DOMSATS. The gateway defined by the Study is similar in most respects to those anticipated for DOMSAT use. Distinguishing features are the uniformity of design from one gateway to the next and the large numbers, perhaps thousands, that are expected to be needed. All dispatch operators and wireline and radio common carriers for radio will use the gateways (instead of radio towers as in the case of terrestrial systems) to establish the local connection. As was described previously, the gateway eliminates all TELCO service charges for dispatch, and enables RCC's and WCCs to minimize total system cost considering both gateways and his own TELCO network, if any.

Recognizing the importance of a low cost gateway to LMSS economy and flexibility a Gateway Developmental Program (POC) to reduce cost and standardize equipment is a contribution to an effective LMSS. Important elements for this development are:

Table 4.8-6. Space Segment Technology Assessment

| ITEM | CHARACTERISTICS | ISSUES | PROGRAM |
|--------------------------------------|--|---|---|
| DEPLOYABLE MULTIPLE BEAM UHF ANTENNA | ≈ 34 FEEDS, (INCLUDING OFF-SHORE), 28 METERS, OFFSET FED, UHF RECEIVE TRANSMIT | DEPLOYMENT IN GEOSYNCHRONOUS OR STS ORBIT (WITH RETRACTION CAPABILITY), EVA SUPPORT (?), MECHANICAL PROPERTIES FOR ATTITUDE CONTROL AND SECONDARY PROPULSION, LOCATION OF LNA'S, HPA'S | REQUIREMENTS DEFINITION STUDY, PHASE "C" LARGE APERTURE DEVELOPMENT, PHASE "C" DESIGN STUDY, FEED POC |
| SPACECRAFT BUS | ~ 3950 LBS, 1800 WATTS, STS LAUNCHED | ANTENNA STORAGE AND DEPLOYMENT, FEED STORAGE AND DEPLOYMENT, CONVENIENT CG SYSTEM, RF AND DC POWER LINE LENGTHS, MECHANICAL RESONANCE, STIFFNESS, MOMENTS | REQUIREMENTS DEFINITION STUDY, PHASE "C" DESIGN STUDY |
| FILTERS/DIPLEXERS | FREQUENCY TRANSLATION, DIPLEXING | SELF INTERFERENCE FROM SPURIOUS, ACTIVE PASSIVE INTERMODULATION INTERFERENCE WITH SATELLITE RECEIVER, SATELLITE USE-FUL BANDWIDTH, RERADIATION OF OUT OF BAND INTERFERENCE, RECEIVER INTERMODS CAUSED BY OUT OF BAND INTERFERENCE, EFFICIENT RECEIVE, TRANSMIT DIPLEXING, GAIN S'ABILITY, LIGHTWEIGHT FILTERS, DIPLEXER'S, CONVERTERS | REQUIREMENTS DEFINITION STUDY, PHASE "C" DESIGN STUDY |
| LAUNCH VEHICLE | IUS OR IUS DERIVATIVE OR ALTERNATIVE | COST | REQUIREMENTS DEFINITION STUDY, PHASE "C" DESIGN STUDIES |
| FIXED LINK | SINGLE BEAM FOR CONUS (PLUS OFFSHORE SPOTS) ~ 5', TWTA POWER | SSPA ALTERNATIVE, TWTA REDUNDANCY SCHEME | REQUIREMENTS DEFINITION STUDY, PHASE "C" DESIGN STUDY |
| LINEARIZED UHF AMPLIFIERS | 12 WATT MODULES, EFFICIENCY GREATER THAN 35% | EFFICIENCY, INTERMODULATION LEVELS, REDUNDANCY ARRANGEMENTS | LINEAR AMPLIFIER POC |
| ACS | POINTING CAPABILITY ≈ 0.2° | STABILITY, ON ORBIT ASSESSMENT, ADJUSTMENT OF PARAMETERS, EFFECT OF FLEXIBLE STRUCTURE, EFFECT OF CG | REQUIREMENTS DEFINITION STUDY, PHASE "C" DESIGN STUDY |
| SECONDARY PROPULSION | STATIONKEEPING = 0.1° | EFFECT OF CG, LOCATION OF THRUSTERS, THERMAL CONTROL, REDUNDANCY | REQUIREMENTS DEFINITION STUDY, PHASE "C" DESIGN STUDY |
| POWER | 1800 WATTS, SUBSTANTIAL ECLIPSE CAPABILITY | NONE (LIGHTWEIGHT MODERN ARRAY, NICKEL HYDROGEN BATTERIES) | REQUIREMENTS DEFINITION STUDY, PHASE "C" DESIGN STUDY |
| THERMAL | ANTENNA SHADOWING, DISPERSED ACTIVE COMPONENTS, ECLIPSE TEMPERATURE-PASSIVE SYSTEM | NONE | REQUIREMENTS DEFINITION STUDY, PHASE "C" DESIGN STUDY |
| TT&C | CONVENTIONAL SYSTEM | NONE | REQUIREMENTS DEFINITION STUDY, PHASE "C" DESIGN STUDY |

1. Operator installed systems - to minimize out of pocket costs.
2. Integrated RF/IF subassemblies
3. Solid state HPA's (suitable for low capacity gateways) to minimize maintenance.
4. Standardized MODEMS (data and voice), frequency synthesizer, and control.
5. Standardized echo canceller for radio telephone.
6. Standardized TELCO and satellite system signalling architecture.

4.8.4.4 Mobile Radio

It is anticipated that a great variety of services will emerge from LMSS operations, leading to a wide variety of mobile equipment choices. Users may use land, sea, or air vehicles, or walk, be interested in transportable (operate while motionless), mobile, or pedestrian operation, desire dial-up voice, dial-up data, simplex voice/data or interactive data/position location. Basic services are compatible radio telephone (an integrated, large network), stand-alone radio telephone (an integrated, large network), and dispatch (private network). Users can choose antennas ("fixed", steerable, or "pedestrian" types), tuned or fixed tuned transceivers according to their individual needs.

Three steps are recommended to prepare the way for the timely introduction of this equipment. The first of these, the "Mobile Antenna Development" (POC), should design, build, test and characterize a representative low cost example of a fixed vehicle antenna, a mechanically, and an electronically steered antenna, and a pedestrian antenna (4 antennas), including consideration of manufacturing tolerances, installation, esthetic appearance, windage and vandal problems. This program should benefit from consultation with mobile equipment manufacturers. Gain, circularity, ground skip rejection and antenna noise temperature are important parameters.

A second program "Mobile Radio Field Test and Demonstrations", enables an evaluation of service availability, using various antennas, in different service environments (cities, suburbs, rural areas, mountainous regions, Alaska, etc.), using IMMARSAT, MSAT or ATS-3 to provide statistical data on

communications availability and improvements despite shadowing, ground skip, multi-path from buildings, etc., man-made noise and land grade. This program can provide important data on the degree of antenna complexity required (and cost) to provide adequate acceptable service.

A recommended program is a Mobile Radio Design Study (2) performed by mobile radio equipment manufacturers, of typical mobile radio designs taking into account the LMSS communications and signalling architecture, LMSS service standards and specifications, and the radio environment (mutual dispatch or cellular interference, etc). This study can resolve specification or standards conflicts and, most important, prepare the mobile radio equipment industry for its entry into the manufacture of satellite compatible equipment.

Some preparation is needed because satellite compatible designs, while similar to terrestrial designs, differ in important ways. Examples are the antenna, the need for a low noise front-end, different modulations and channel spacings, linearized HPA's and different signalling protocol. Lack of preparation can result in tardy equipment introduction and consequent satellite under utilization with disastrous economic consequences for the commercial entity. Of course, in Scenario "A" the commercial entity could share in the cost of these development programs, perhaps in all three (or perhaps in none).

4.9 SPACECRAFT CONFIGURATION

4.9 SPACECRAFT CONFIGURATION

4.9.1 INTRODUCTION

Orbital geometry for the LMS spacecraft is shown on Figure 4.9-1. This concept uses the LMSC wrap-rib or "Flex-Rib" deployable reflector and collapsible truss deployment booms as described on pages 461 through 464 of Reference (2). The 1.8 Kw solar array is the MBB type frame membrane design using 6 1.1 x 3.3 meter panels, each providing 300 watts EOL power. An empty panel frame and yoke are provided to position the solar cells outside the 23-1/2 degree sun line to preclude solar cell shadowing by the aft module.

To efficiently control this large spacecraft, it will most likely be necessary to provide Reaction Control Subsystems (RCS) and reaction wheels in both the lower and upper or aft modules. All payloads and housekeeping electronics are contained in the lower module to minimize the power and signals to be transferred between the deployed modules.

4.9.2 LAUNCH CONFIGURATION

The large size of the orbital LMS spacecraft requires extensive compacting for launch stowage in the STS and multiple on orbit deployments to achieve the final operational configuration. The 17' x 17' UHF feed is folded into three equal width segments for stowage on two sides of the spacecraft BUS section as shown on Figure 4.9-2. The Ku-Band antenna reflector and solar array are folded and secured to the remaining BUS sides, also shown on Figure 4.9-2. The BUS section is attached to the IUS by a tubular truss aft module/support structure as illustrated on Figure 4.9-3. The aft module houses the stowed BUS/feed truss boom and the furled reflector and its collapsed boom section. Also located in the aft module is an independent reaction control subsystem, and if required, an independent set of reaction wheels. The aft module is attached to the BUS and IUS adapter trusses at four separation points using dual pyro activated separation nuts. As shown on Figure 4.9-3, the spacecraft/IUS assembly has a total stowed length of 47.4 feet providing ample clearance in the 60 foot long cargo bay. The IUS is positioned as shown to insure that the combined spacecraft/IUS cargo meets the STS cargo weight and center of gravity criteria.

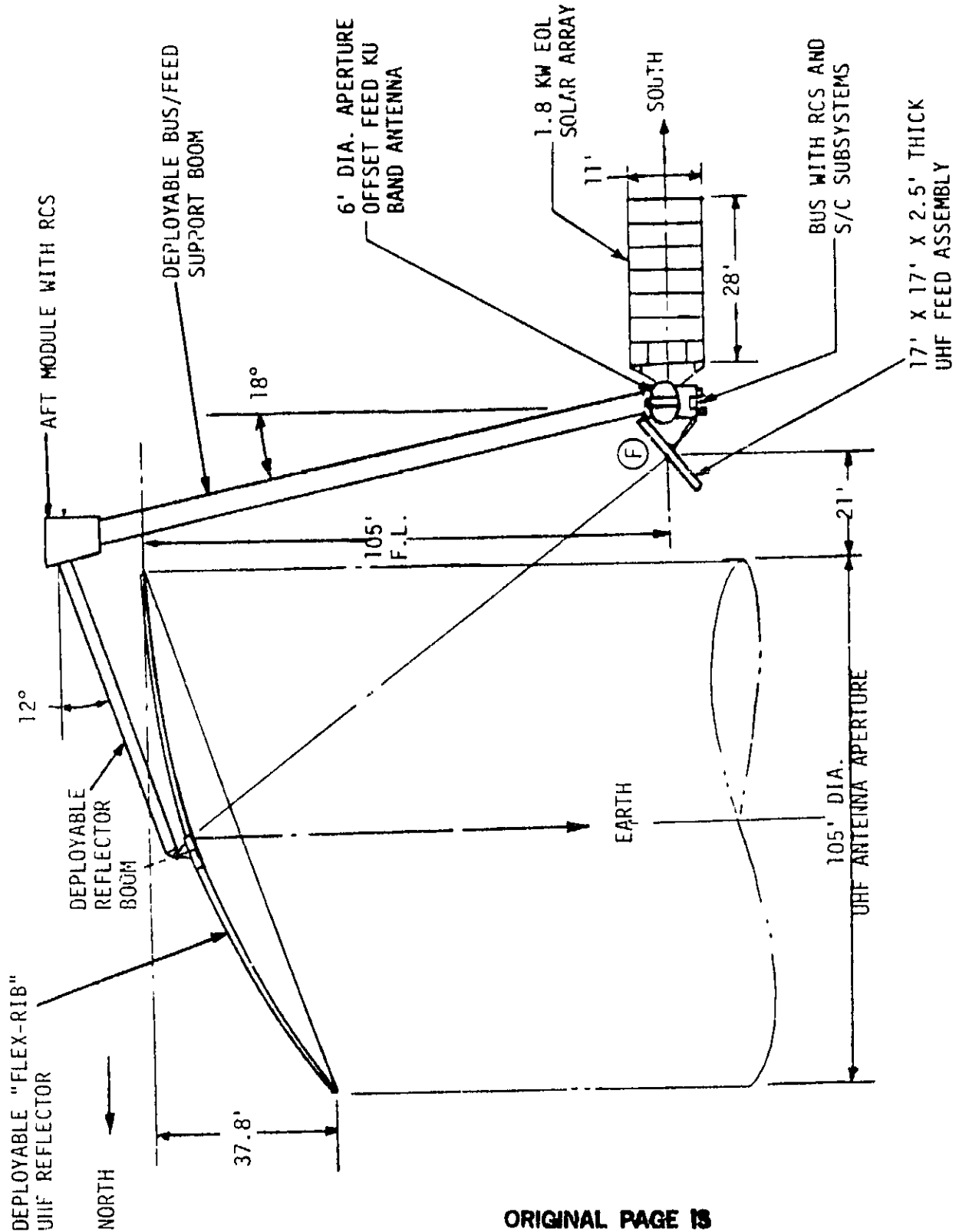

Figure 4.9-1. Orbital Geometry

ORIGINAL PAGE IS
OF POOR QUALITY

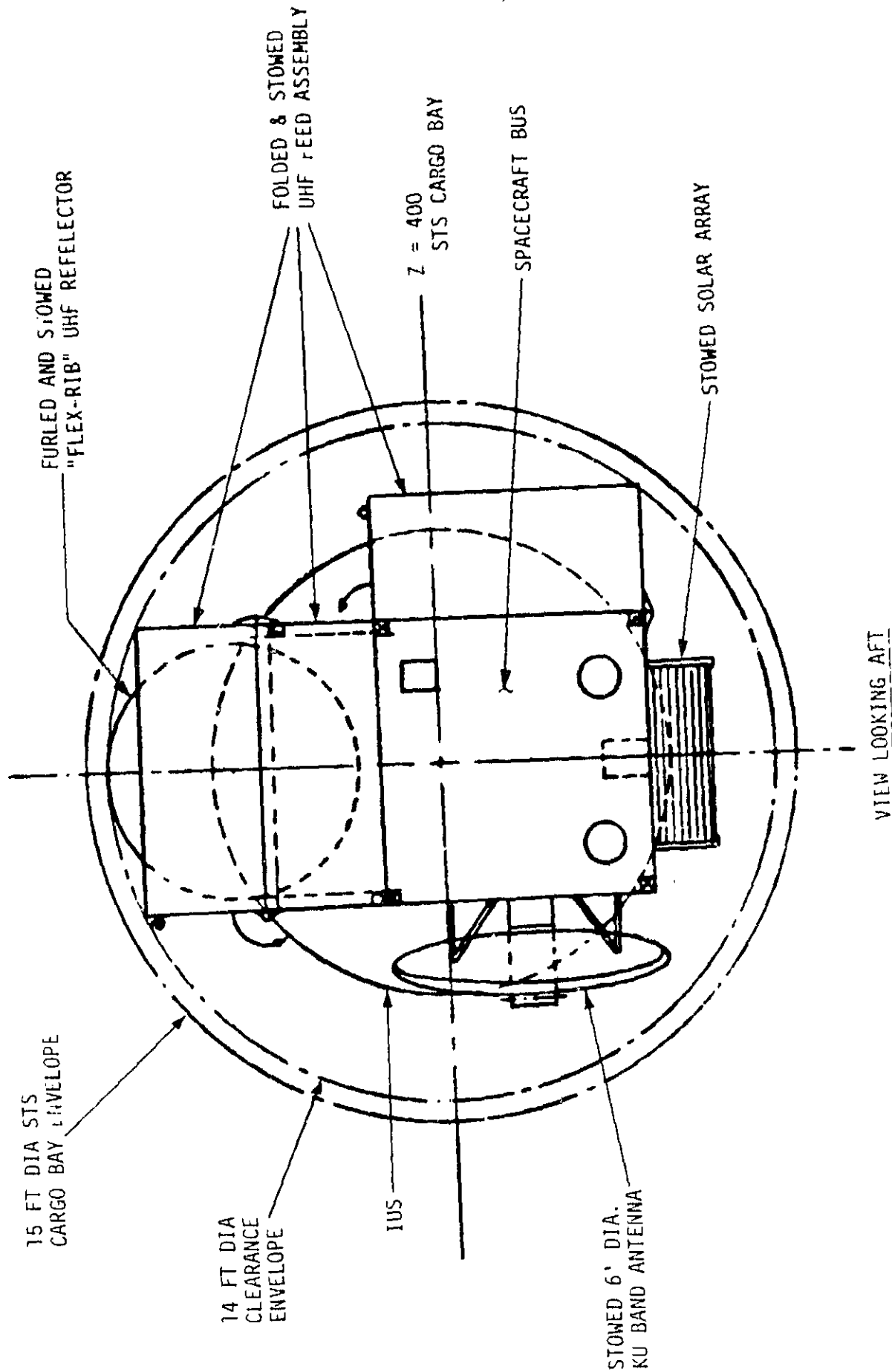

Figure 4.9-2. STS Configuration, End View

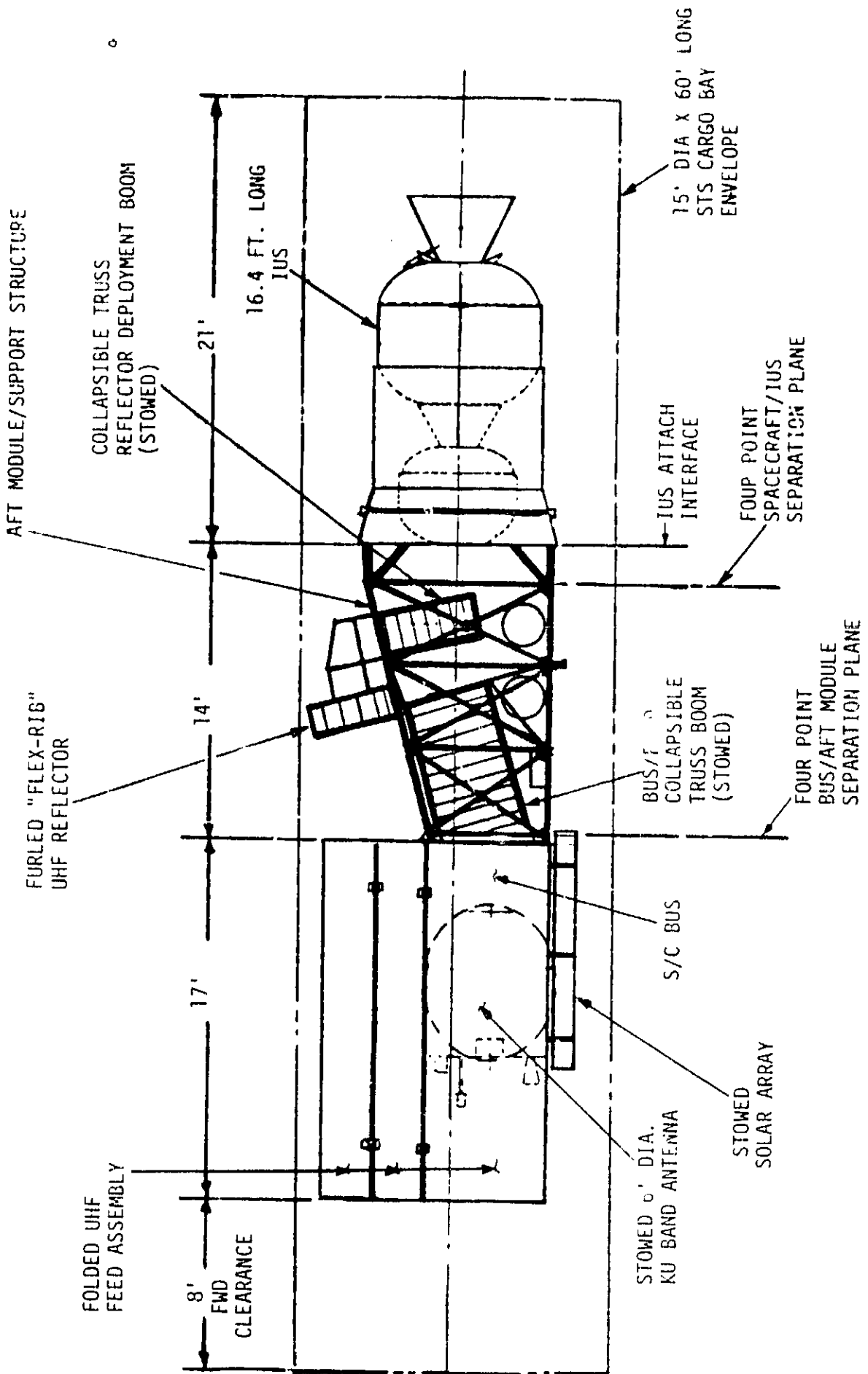

Figure 4.9-3. STS Configuration, Side View

The spacecraft length of 31 feet cantilevered from the IUS forward attach interface may exceed the IUS interface load and bending moment capability requiring a forward auxiliary support cradle for the spacecraft. An alternate launch support concept is to provide independent launch support systems for the spacecraft and IUS with remote latches used to join the two assemblies after SIS injection and prior to IUS/spacecraft erection and ejection from the SIS.

After SIS launch to the low earth parking orbit, the spacecraft/IUS assembly is erected and ejected from the STS near the equatorial crossing. After achieving the required separation distance from the STS, the two stage IUS is used to inject the spacecraft into the final geosynchronous mission orbit.

9.3 ORBITAL CONFIGURATION

The LMS spacecraft is separated from the remaining IUS second stage after injection and deployed to the operational configuration as follows:

1. The aft module to BUS separation joints are released and the main BUS/feed collapsible truss extended to separate the two segments.
2. The furled UHF reflector and boom launch locks are released and the reflector boom extended.
3. The 105 foot diameter UHF "Flex-Rib" reflector is released and unfurled.
4. The UHF feed is released, unfolded and extended to the final canted position.
5. The 6 foot Ku-Band reflector is released, unfolded, and latched.
6. The solar array is deployed to complete the spacecraft deployment sequence.

The LMS spacecraft orbital configuration is shown in the operational orientation on Figure 4.9-4, with all appendages fully deployed. On orbit control and position are maintained by the BUS and aft module RCS/wheel systems using ACS reference data and control logic from the BUS mounted attitude control subsystem sensors and electronics.

REFERENCES

- (1) Lockheed Report LMSC/D 38 4797.
- (2) NASA Conference Publication 2215, Part 2, "Large Space Systems Technology", November 1982, Boeing LMSS System Spacecraft.

PRECEDING PAGE BLANK NOT FILMED

4.10 REGULATORY AND INSTITUTIONAL ASPECTS

The terrestrial systems described in Volume II do not require any regulatory or institutional changes. This section is concerned only with regulatory and institutional aspects of satellite systems.

4.10.1 Regulatory Aspects

4.10.1.1 Frequency Allocation Considerations

At the time of this writing the regulatory aspects are dominated by the problem of frequency allocation. The World Administrative Radio Conference in 1979 (WARC 79) authorized the frequency band 806-890 MHz for land mobile satellites. Within the United States the band is allocated for terrestrial land mobile. The Federal Communications Commission has studied the needs for present types of land mobile services and determined that by 1990 there will be a shortage of available land mobile capacity for present types of services in 19 major geographic areas and by 2000 there will be a shortage in 21 major areas.⁽¹⁾ The Commission is therefore very reluctant to introduce satellites into that frequency band, viewing satellite land mobile as a new service, and one that uses the spectrum less efficiently than other land mobile services. The proposed introduction of satellites into the band has alarmed many present service and equipment suppliers who have expressed their alarm in strong terms to the FCC.

Neither the FCC nor the service and equipment suppliers oppose satellite land mobile in principle. The important issues — the need for land mobile services that satellites can fill, and the business opportunities that they offer—tend to be clouded by the concern over their introduction into the 800-900 MHz frequency band.

This study is primarily concerned with the need for satellite-aided land mobile, its advantages for some specific applications, and its technical and economic feasibility. The study results show clearly that satellites can and should play an important role in future land mobile services. The frequency allocation problem must be resolved and a suitable allocation made for the land mobile satellite system.

The use of the 806-890 MHz band was assumed in the study because it is the band allocated by WARC 79 and because it makes possible the implementation of a ubiquitous mobile radio telephone system through compatibility with the urban cellular mobile radio telephone systems. Most of the satellite applications identified in Volume I do not require compatibility with terrestrial systems, and their technical requirements can be met at frequencies above 890 MHz. Other frequency bands should be considered for the service if there is a consensus that the service cannot be accommodated in the 806-890 MHz band.

A rather broad band of frequencies is technically suitable for land mobile satellites. A major consideration is the vehicle antenna design. The most suitable designs are omnidirectional in azimuth with a vertical pattern that discriminates against ground reflections and has some gain at all elevation angles to the satellite throughout the service area. The pattern should be achieved with vehicle antennas that are small in size, low in cost, and suitable mechanically and aesthetically. Antennas that meet the requirements can be built for the 800 MHz band, but below that frequency they may be physically too large to be acceptable. Above 3000 or 4000 MHz the physical size and aperture of the antennas becomes too small unless they are made directional in azimuth and elevation. As indicated in Section 4.6.2.4 it may be practical

⁽¹⁾ Future Private Land Mobile Telecommunications Requirements, Interim Report, August 1982, Prepared by: Planning Staff, Private Radio Bureau, Federal Communications Commission.

to build steerable antennas for vehicles. At frequencies above approximately 5000 MHz the azimuth and elevation beamwidths may become so narrow that low-cost, accurately steered antennas for most land vehicles may not be feasible. L-band, 1550-1650 MHz was found to be a near optimum choice for land mobile when tests were made with NASA's ATS-6 satellite. A portion of that band is now allocated for aeronautical mobile but is unused.

The reserve bands in the 806-902 MHz spectrum should be allocated to the services that are deemed most valuable. Value depends on the number of persons served and also on the services offered. The following comments, though simplistic, may contribute to an understanding of the relative merits of allocating the reserve bands to satellites or to additional terrestrial channels. The FCC future requirements study⁽²⁾ lists the populations of the 21 market areas in 1980, 1990, and 2000. The total population of the areas is expected to be 88,384,000 in 1990. The report lists a total of 115 MHz for land mobile between 806 and 947 MHz. If a total of 20 MHz (10 MHz uplink, 10 MHz downlink) is the bandwidth under consideration for satellites, it affects 0.174 of the total allocation.

If the 20 MHz are assigned to the terrestrial systems, quality of service can be maintained for 15 million more persons in the 21 markets than would be served at the same quality if the 20 MHz is assigned to the satellite. No new services would be introduced. It is recognized that all of the 21 markets will have demands for more terrestrial services than can be supplied within the 155 MHz bandwidth unless new techniques or procedures can improve the efficiency of spectrum usage. The rest of the nation's population, about 150 million persons, will have adequate terrestrial mobile services within the band.

If the 20 MHz is allocated for satellites, approximately 60 million persons in non-urban areas will benefit directly. The satellite will provide needed new services and functions that will have economic benefits for the whole nation. An important issue is the capacity of a satellite system to serve a number of users that is comparable to the total that could be served in the same bandwidth as the terrestrial systems. It is shown in Section 4.2.4.1 that a 100 beam satellite system can provide approximately 62,500 simultaneous duplex voice channels in the 20 MHz allocation. That is about the same number that can be served in the total SMSA area of the contiguous states in the same bandwidth by terrestrial systems as shown in Section 4.10.2.2. A single beam satellite system would serve about 2500 voice channels, and a 31 beam satellite would serve about 6250 duplex voice channels.

The FCC requirements study refers to "links," which can be simplex or duplex voice or paging channels. If the concept of links is applied to the satellite, with its greater variety of functions, the number of links can be very large, because many of them will be used for narrow band data and position location. As many as 50,000 trucks can be accommodated in one 4 kHz channel because their narrow bandwidth digital messages are short and infrequent.

All of the spectrum below 10,000 MHz has been allocated. New services can be accommodated only by changes in the present uses of the spectrum. With regard to land mobile the FCC comments:⁽³⁾

"The potential sources of additional communications capacity for private land mobile communications can be grouped into the following four categories:

- A. Release of all allocated land mobile reserve;
- B. New allocations/sharing;

⁽²⁾ Op. Cit., p. 27ff.

⁽³⁾ Op. Cit., p. 44.

- C. Additional sharing among the land mobile services;
- D. New technologies/systems.”

The development of space technology has introduced a means of providing mobile radio services and functions that are new and important. The study that led to this report has identified needs for satellites in mobile radio services, and determined that large numbers of users can benefit from properly designed space systems. From a purely technical point of view, there is a wide choice of spectrum that is suitable for satellite land mobile, and the favorable propagation characteristics make it possible to communicate with narrower channel bandwidths than are used in terrestrial systems. Valuable services can be provided by satellite within a comparatively narrow spectrum allocation with considerable freedom to choose the portion of the spectrum in which the allocation is made. Other considerations, such as compatibility with other mobile systems should be taken into account in selecting the band. The important opportunity offered by space technology deserves serious consideration by regulatory agencies.

4.10.2 FCC Policies

4.10.2.1 Allocation Criteria of FCC

The Federal Communications Commission has "...developed a set of criteria, or principles, by which it determines whether a proposed use (of the spectrum) is to be defined as a radio service, and thus to be allocated a portion of the spectrum. These principles are, in effect, a statement of FCC policy for spectrum allocation."⁽⁴⁾

"The essence of these principles may be stated as follows:

- 1) Whether the service in question really requires the use of radio or whether wireline is a practical substitute;
- 2) Radio services which are necessary for safety of life and property deserve more consideration than those which are more in the nature of conveniences or luxuries;
- 3) Where other factors are equal, the Commission attempts to meet the request of those services which will render benefits to the largest segment of the population;
- 4) Whether the service meets a substantial need and has a reasonable probability of being established on a viable basis;
- 5) Consideration of the most suitable place in the spectrum to satisfy the requirements of each particular service, and finally;
- 6) Consideration of industry and public investment already committed to a particular frequency band."

"Analysis of past decisions indicates that safety of life and property, service to large numbers of people, and committed capital investment are given the most consideration."

4.10.2.2 FCC Criteria Applied to Land Mobile Satellite Service

Need for Radio

Communications with moving vehicles obviously require radio. There are no other significant means. Terrestrially based mobile radio systems are limited in service range and coverage. Satellites can overcome the deficiency.

⁽⁴⁾ Op Cit., p. 41.

Services Necessary for Life and Property

Mobile radio is vital to services related to the safety of life and property. Terrestrial mobile radio techniques are inadequate to support these important services in rural and remote areas. Satellites can overcome the deficiencies and provide these much needed services where they are not now available.

Benefits to Large Section of Population

Volume I identifies three market categories for mobile services that may be satisfied by the use of satellites, but which may not be satisfied by any other means. Their economic and social benefits cannot be questioned. A satellite with large beam footprints on the earth provides less opportunity for frequency re-use than terrestrial systems, and thus may require more spectrum per user than terrestrial systems. The severe limitation of spectrum that can be allocated to mobile radio makes it necessary to determine if the loss to terrestrial mobile users through the satellites would be greater than the advantages gained by those who would benefit from the services provided by satellites.

The prospect of using satellites for mobile radio applications presents the Federal Communications Commission with difficult choices because the use of spectrum to satisfy mobile radio requirements could eventually result in the denial of services either to persons who live in densely populated areas or to persons who live in thinly populated areas. The great difference in population density throughout the contiguous states lies at the root of the problem. In Reference I the FCC presents the future mobile spectrum requirements of 21 large metropolitan areas. It can be shown that there is not enough spectrum allocated to satisfy all of the requirements in those areas, yet most of the country will not require the full use of the available spectrum to meet its needs.

Important needs exist in non-urban areas of the country that are unlikely to be met by the use of terrestrial techniques but that could be met by the use of mobile satellites. Satellite systems could meet the needs, but the spectrum cannot be shared by terrestrial and satellite systems without severe interference to the satellites. It is therefore necessary to consider that the use of satellites to serve non-urban areas might limit the spectrum that is available to avoid saturation of the spectrum within urban areas. These facts present a difficult dilemma. Service may have to be limited to a level below demand in some densely populated urban areas, or service must be denied to potential users of the satellite system in thinly populated areas. The situation requires a decision with important economic and sociological implications.

One approach to resolving the dilemma is to identify the users in the urban and non-urban areas who are denied service by the decision to use or not to use satellites. The economic and sociological impacts of the denial should then be considered.

If satellites are not used, the requirements identified in Volume I will not be met adequately. The New Services are not likely to be satisfied at all, the Commercial and Public Radio users will continue to have the limitations of range, coverage and function that are now the basis for dissatisfaction, and the mobile radio telephone will not be implemented in many small communities in rural and remote areas.

If satellites are used, the quality of service for business, special industrial, and some public and safety services in a few of the largest metropolitan areas will suffer from channel overloading unless some significant technical advances are implemented to permit a larger number of users per channel or unless more spectrum becomes available than is now anticipated. The introduction of new technologies to increase the capacity within available spectrum allocations

is always slow because they may require the replacement of user equipment; for example, a conversion to compandored single sideband would make obsolete the presently used frequency modulation equipment. The replacement cannot be imposed more rapidly than the normal replacement rate of user equipment, and thus the introduction of new technologies would take place over decades, and not result in a rapid increase in channel capacity. The availability of new spectrum for mobile radio suffers from the tremendous competition from many other legitimate users and potential users of the precious, limited resource. Modern technology and ingenuity continue to find new ways to use radio.

The numbers and types of users who are denied service in each area, urban and non-urban, can be estimated. Spectrum efficiency can be estimated by considering the frequency re-use potential of a single channel in the terrestrial and satellite systems. An estimate is made for each type of service. Where appropriate, we assume the markets to be the "most likely" estimates of Volume I.

For mobile radio telephone, present urban cellular systems employ frequency modulation with 30 kHz channel separation for a total of 666 channels. The channels are divided into seven subsets of 95 channels each to serve seven cell clusters for the purpose of avoiding co-channel and adjacent channel interference. The description of the cellular system by the Bell System⁽⁵⁾ states that it is practical to reduce cell sizes in cities to one mile radius. A cell would then have an area of 3.14 square miles. One channel can serve 30 subscribers with an acceptable blocking rate. The number of subscribers in a cell may then be 2850. The likely penetration of the market is equal to one percent of the population. It is apparent that the presently assigned 666 channels could serve population densities as high as 90,000 persons per square mile. There are few if any areas in the country with population densities that large. It would appear that the present allocation for terrestrial mobile radio telephone systems is adequate to meet foreseeable needs, perhaps without reducing cell sizes to their smallest practical size.

Mobile radio telephone service in non-urban areas can be supplied by terrestrial systems where the population density justifies the investment. Volume I, the market study, and Volume II, the terrestrial concept, conclude that terrestrial systems may be economically justified in all the SMSA counties of the contiguous states. It does not appear likely that terrestrial systems will make a significant penetration of the non-SMSA counties. The total population of the non-SMSA counties is 7,600,000. If a spectrum allocation is made for satellite mobile outside the present allocation for terrestrial cellular, the non-SMSA counties can be served without affecting the terrestrially based cellular service in the SMSA counties.

The allocation of spectrum for satellites must be weighed against other mobile uses for spectrum. Efficiency in the use of spectrum may be evaluated by considering the re-use ratios of a single channel in the terrestrial and satellite systems and the number of persons that each would serve in the urban and non-urban areas. For mobile telephone, the average range of a terrestrial installation is eight miles except in cities where range has been purposely limited by using small cells. It should be noted that ten installations are used in the first Chicago installation where cell splitting has not yet been implemented.

The average service area of a terrestrial installation is thus 200 square miles. Thirty subscribers may be served by the single channel in one service area. A single channel in a cellular system is used in one seventh of the terrestrial installations in accordance with the assignment plan that is designed to minimize co-channel interference. If the entire area of all the SMSA counties were served by terrestrial installations, the number that would use the single

⁽⁵⁾ Bell Systems Technical Journal, Jan., 1979, Vol. 58, No. 1, p. 30.

channel would be 321. The largest possible number of subscribers served in SMSAs by the channel would be 9643. The actual number would be smaller because many areas within the SMSA counties have a population density too low to justify terrestrial installations. The average population density of the SMSAs is 385 persons per square mile.

A one hundred beam satellite with a frequency reuse ratio of 4 would have 25 beams that used the channel. With thirty subscribers per channel-beam the total number served is 750. If full advantage is taken of the favorable propagation characteristics of the satellite links, the modulation technique may be amplitude-companded single-sideband or a form of linear predictive coding digital modulation. The bandwidth per channel is 4 kHz rather than the 30 kHz of the terrestrial cellular compatible system. If that seven to one greater usage of the spectrum is realized, the channel used on the satellite would serve 5250 subscribers. If polarization diversity for the satellite-mobile links proves practical, an additional factor of two may be realized so that the satellite may serve approximately 10,500 subscribers in the same channel bandwidth that would serve 9000 urban subscribers in the terrestrial system. The favorable propagation characteristics of the satellite links would support the use of the narrow band modulation and polarization diversity techniques, but at the cost of poor compatibility with the terrestrial systems. As noted previously the total capacity of a 100 beam satellite with a 20 MHz allocation is 62,500 duplex voice channels without the polarization diversity.

The satellite installation cost is not sensitive to population density, but only to the aggregate number of subscribers within a beam footprint. It is reasonable to expect that the satellite will actually serve a larger portion of its potential market than the terrestrial system because of the terrestrial system's sensitivity to population density.

Need for Service and Probability of Implementation

The fourth criterion of the FCC considers whether there is a substantial need for the service and whether there is a reasonable probability that it will be implemented on a viable basis. The need for mobile radio services in thinly populated areas could be met by satellite systems, and the technical feasibility of fulfilling the needs by satellite has been shown by many demonstrations with NASA satellites. The costs per user are reasonable for the satellite system, but not for a truly nationwide terrestrial system.

Implementation of a satellite system requires that some entity invest the large amount of money necessary to launch a satellite and build the earth station facilities before the market has been developed. It is probable that a group of industries with important, unmet needs might form a consortium to implement a system. This study cannot assess the "reasonableness" of such a probability, but it does seek to present information that is useful in evaluating the economic as well as functional and technical feasibility of implementing such a system.

Suitable Place in Spectrum

The fifth criterion addresses the portion of the spectrum that should be allocated to a particular service. The choices for mobile radio are limited to bands near 30, 150, 450, and 850 MHz for the land mobile service. Consideration may also be given to L-band, 1550-1650 MHz that contains allocations for maritime and aeronautical mobile.

Mobile radio services in non-urban areas have different propagation requirements than mobile services in urban areas. In cities, short ranges are desirable in order to provide for frequency re-use, as in the cellular systems. In non-urban areas, maximum range is desired to minimize the number of repeater installations and to serve the generally longer distances over which communications are needed.

The 806-890 MHz band is well suited to the urban cellular systems because of its short range. Its short wavelength is also an advantage because it provides somewhat better building penetration than the lower frequency mobile bands. The band is not well suited to non-urban terrestrial mobile radio because the propagation ranges are short and many repeaters are needed to cover large service areas. As noted in Volume II, Uppal and Edwards report that signal attenuation at 30 km range is 19.8 dB greater at 850 MHz than it is at 150 MHz. An attempt to increase range by increasing the power can be expensive. There is less diffraction of 850 MHz signals than at lower frequencies, and therefore terrain features block the signals more severely than at lower frequencies, making deeper shadows behind hills and structures. Increased tower height is not effective because the signal attenuation is mostly by obstructions in the vicinity of the mobile. The characteristics that make the 806-890 MHz band attractive for the urban cellular systems make the band unattractive for terrestrial non-urban mobile communications.

Satellite-mobile communications do not have a frequency dependent range limitation. They do suffer greater foliage attenuation at 850 MHz than at lower frequencies, but the high elevation angles to the satellite reduce the probability that it will occur compared to the terrestrial systems. Satellite mobile communications are essentially communications between two points in free space, as demonstrated by many experiments with NASA's ATS satellites, and as reported in the literature.⁽⁷⁾

The 806-890 MHz band is in the optimum portion of the spectrum for mobile communications. It has the following advantages:

- Vehicle antennas can be small, ^(8,9) have sufficient aperture and gain, vertical patterns to avoid ground reflections yet accommodate the changes in elevation angle to the satellite as the vehicle moves throughout the country, and have a pattern that is omnidirectional in azimuth so that steering is not necessary. The antennas can be inexpensive.
- Satellite antennas can be built with sufficient gain to concentrate their transmitted energy on the nation, or to have a number of beams that can provide effective frequency re-use.
- Ionospheric propagation effects are lower at 850 MHz than at lower frequencies. Faraday rotation, scintillation fading, and group delay within the ionosphere have only small effects on signal polarization, amplitude and phase fluctuations, and range measurement errors.

The propagation characteristics of the 806-890 MHz band make it the best available choice for urban cellular systems, but a poor choice for non-urban terrestrial systems. The wavelength of the 806-890 MHz band makes it a near optimum choice for non-urban satellite mobile communications. If channels within the band are assigned for satellite use, the opportunity exists to provide the nation with a ubiquitous radio telephone system in which the subscribers use the terrestrial systems in densely populated areas and the satellite system in thinly

⁽⁷⁾ *Mobile Communications*, William Lee, McGraw Hill.

⁽⁸⁾ General Electric Company, "Satellite-Aided Mobile Communications Limited Operational Test in the Trucking Industry" July 1980, Final Report on NASA Contract NAS5-24365. The test was conducted at L-band using ATS-6. Antennas on the trucks were 30 inches tall, one inch in diameter, of the Wheeler type with patterns as described here.

⁽⁹⁾ General Electric Company, "Final Report on Application of Satellite Communications and Position Fixing Techniques to Land Mobile Systems," Contract DEA-76-20. GE Report SRD-77-01. Describes experiments with a station wagon linked to ground stations through the VHF (150-135 MHz) transponders of ATS-1 and ATS-3.

populated areas. Accommodation of satellites within the band may increase the overall efficiency of spectrum usage. Some limited sharing of channels may be possible because the satellite downlink signals cannot interfere with the urban cellular systems.

Industry and Public Investment Already Committed

The sixth criterion of the FCC considers the industry and public investment already committed to a particular frequency band. Industry investments in the terrestrial cellular and other systems in the 806-890 MHz band are very large. Cellular mobile telephone promises to make an important advance in the use of mobile radio. The investments and promise must be protected. Specific assignments of channels are being made at the time of this writing, and cannot be revoked once they are made.

Balanced against the commitments are the needs for the same kinds of services in non-urban areas. Despite some claims to the contrary, unimpeachable experimental evidence and propagation calculations based on theory clearly show that the 806-890 MHz band is not well suited to terrestrial mobile use in thinly populated areas. In a private communication, a representative of a concern that assists applicants for cellular licenses stated that his concern discourages entrepreneurs who wish to apply for licenses in communities below 100,000 population. All of the evidence leads to the conclusion that a large portion of the nation's population will not benefit from the 806-890 MHz frequency allocation if it is used solely for terrestrial systems. That portion of the population could benefit if some portion of the band is used for satellite-aided mobile communications. The potential benefits were recognized by the 1979 World Administrative Conference when it authorized the use of the band for satellites in Regions 2 and 3.

4.10.2.3 Status of Frequency Allocations

The Land Mobile Satellite service was recognized internationally when the World Administrative Conference in 1979 authorized Land Mobile Satellites in the frequency band 806-890 MHz. The authorization was made for Region 2, North and South America, for Region 3, Asia, and for Sweden and Norway in Region 1.

The Federal Communications Commission has not yet allocated a spectrum within that band for satellites. NASA has played a key role in presenting the case for land mobile satellites to the FCC, culminating in a "Petition for Rulemaking — Mobile Satellite Service" that was filed on November 24, 1982. In that petition "NASA proposes that the Commission promptly institute rulemaking to consider the following:

1. Allocation of 821-825 MHz and 866-870 MHz (both currently in reserve) to the Mobile Satellite Service on a primary basis.
2. Continuation of the reservation of 845-851 MHz and 890-896 MHz until 1990, to maintain the availability of sufficient spectrum for the commercial phase of a Mobile Satellite Service while the results of an experimental use of 821-25 and 866-70 MHz bands... are evaluated.
3. Allocation of from 35 MHz to 80 MHz of spectrum in each direction at S-band, or Ku-band, for "feeder-link" purposes, i.e., for access to and from the Mobile Satellite by fixed satellite earth stations to be interconnected to the Public Switched Telephone Network ("PSTN") and to other terrestrial communications systems, such as base stations for private mobile operations."

NASA also called attention in the Petition to the underutilized segment of the 1500-1600 MHz (L-band) that is currently allocated to Aeronautical-Mobile services. "NASA does not here propose an immediate allocation of L-band spectrum for Land Mobile Satellite use... However, in the anticipation that the mobile communications market will experience substantial growth over the next two decades, and that there will develop sufficient demand for Mobile satellite services of a type not requiring interoperability with 800 MHz cellular and Private Systems, NASA suggests that the Commission give consideration to the future allocation of up to 20 MHz of L-band spectrum (10 MHz for uplink, and 10 MHz for downlink) for Land Mobile Satellite services."

The FCC is under great pressure to assign spectrum in the 800-900 MHz band to services other than satellite mobile. Cellular and private users would like more bandwidth than they now have assigned. Other new services that are requesting allocations include air-to-ground telephone for airline passengers and a new Personal Radio Communications System. We note that the telephone service for airline passengers could be furnished more effectively by satellite and probably at lower cost than the present plan of communication through a nationwide terrestrial network of tower mounted relays.

The FCC staff response has generally been cool to suggestions that spectrum in the 800-900 MHz band be allocated to land mobile satellites. The staff has not perceived as strong an advocacy for the satellite mobile service as it has for the other services. Pressures for the satellite service are building. The Department of Communications (DOC) in Canada is proceeding with a Mobile Satellite (MSAT-X) that will provide mobile services in Canada. NASA and DOC have agreed in principle to a joint Mobile Satellite Experiment that will involve the use of the Canadian satellite for mobile communications in the United States.

4.10.2.4 International Coordination

In addition to solving the problems of spectrum assignment in the United States, coordination with Canada and Mexico is necessary. The satellite beams will overlap the borders of the other countries. There is a potential for interference to the satellite system from other systems in other countries. Perhaps the coordination with Canada is in progress because of the Canadian initiative with their MSAT.

4.10.2.5 Commentary on Regulatory Aspects

All of the spectrum below 10 GHz has been allocated. Every new application of radio communications that needs spectrum below that limit will have to be fitted in by adjustment of current allocations. As technology develops, many allocation readjustments will be necessary.

Land Mobile Satellite Service requires a relatively narrow total bandwidth. It is technically feasible to place the service within broad spectrum limits, but for compatibility with other land mobile services and equipments, some specific assignments are preferred.

The accommodation of LMSS into the spectrum is a subject of active discussion and requests for regulatory action. This report attempts to present information useful to regulatory agencies as they consider the service in comparison with other contending uses of the desired portions of the spectrum. The probable outcome of regulatory actions cannot be predicted at the time of this writing. Regulatory aspects of LMSS are a matter of ongoing concern that require a continuation of the effort that led to this report.

4.10.3 Institutional Aspects

4.10.3.1 Institutions That Provide Services

The institutional arrangement for the Land Mobile Satellite System will be essentially the same as that of the terrestrial mobile radio systems. Services to subscribers will be provided by Radio Common Carriers (RCCs), Wireline Carriers (WCCs), and Special Mobile Radio Services operators (SMRs). Private users, such as large trucking companies, may operate their own gateways as will public service entities.

Space System Operator

The space system, comprising the satellites, the Network Operating Center (NOC), and the Satellite Operating Center (SOC), will be operated by a Space System Operator, a "Carrier's Carrier." Channel assignments for all calls will be made at the NOC, much as the assignments are made by a central computer in an urban cellular system. Records for billing will also be kept at the NOC. The centralized control assures efficient use of the channel capacity and high performance quality. Call placement procedures are described in Section 4.2.1.3.

The space system replaces the long distance telephone network for dispatch and public service users, and most of the long distance network for telephone services. Wireline charges are incurred only for the line between a fixed telephone and the nearest gateway. If there were a gateway for each local office, there would be no long distance wireline costs for any calls.

Radio and Wireline Carriers

An RCC or WCC installs his own gateway with its interface to the telephone network after receiving authorization from the FCC and contracting with the Space System operator. Subscribers may purchase their own mobile telephones or lease them from the RCC or WCC, who may also furnish terrestrial cellular or other mobile telephone services. A call request placed by a mobile is received at the NOC via a common signalling channel. The NOC notifies the appropriate gateway, and assigns the talking channel pair to the mobile and gateway, which then proceed to communicate directly. In-band signalling is available for direct coordination between mobile and gateway after the link has been assigned by the NOC. Bandwidth, and uplink power if appropriate, are assigned by the NOC. If the call is placed by a mobile with terrestrial cellular compatible equipment, a 30 or 15 kHz channel bandwidth is assigned. If the mobile uses 4 kHz single sideband, the corresponding bandwidth is assigned. The NOC monitors the duration of the call, and records a charge based on bandwidth, power and time. The RCCs and WCCs are billed monthly for the service provided by the Space System Operator.

Private Dispatch Users

Private dispatch users with their own gateways will be served by the NOC in the same manner as the RCCs and WCCs. Fleet calling will be provided. Private dispatch users which cannot justify the installation of a gateway will be served by SMRs, who each serve a number of small dispatch users through a gateway.

Public Service Users

Public service users will employ the telephone and dispatch modes. They may choose to share the trunking services provided by the NOC, in some cases obtaining service through RCCs, WCCs or SMRs. In other cases they may install their own gateways and share the trunking services; i.e., the use of demand assigned channels. Discussions with public service users have revealed a reluctance to accept trunking with other users. They express a strong desire to maintain their traditional practice of having channels devoted exclusively to their own use. The Space System Operator may lease channels to public service users at a cost that will provide an adequate return on investment. It is not clear that leased channels will provide better service, but it will be more costly to the users than the trunking service.

Wideband Data Service Users

Wideband data services will be provided in the same manner as the telephone services. Links between the remote data transmission equipment and the central computing facilities will be set up by the NOC. Record-keeping and billing will be NOC functions.

Interactive Data and Position Location Users

Interactive data and position location services will be centralized at the NOC. The low throughput, bursty data does not justify a call setup between a mobile and a gateway for each data transmission. A single data burst may contain only a few hundred bits and may last only a fraction of a second. Position location interrogations and responses are also fractional-second transmissions. A single computer at the NOC can compute a very large number of position locations and thus eliminate the need for a computer at each user's gateway. Centralizing the functions at the NOC greatly improves overall efficiency and reduces cost.

Data collected at the NOC is sorted and transmitted to the users' gateway terminals at intervals appropriate to each user's needs. A typical interval may be once an hour. Priority data, such as an emergency, will be immediately relayed to the user's gateway. Special requests by a user, such as the current condition or location of a specific vehicle, will be fulfilled immediately. The vehicle will be interrogated, and the data will be obtained and relayed back to the user without delay.

A further advantage of centralizing the interactive data and position fixing at the NOC accrues to users who have needs only for those services but only infrequently for a few vehicles. Their needs may not justify the installation of a gateway. They may obtain the service through an SMR, or if none is available to serve them they can obtain it by TELEX or telephone directly to the NOC. The services are thus available at low cost to very small users as well as to large ones.

4.10.3.2 Institutional Arrangement Features

The institutional arrangement for serving LMSS subscribers is already in place. It has the following features:

- Services to subscribers will be furnished by business enterprises that now furnish mobile radio services.
- The types of services that can be offered to subscribers will increase and new markets for the services will open.

- LMSS augments and complements existing and planned terrestrial mobile services. The LMSS services are in addition to the terrestrial services and will not replace or reduce the terrestrial service businesses.
- A new business entity, the Space System Operator, will furnish the centralized control of the system, and other functions roughly corresponding to the centralized control in an urban cellular radio telephone system.
- The use of large numbers of inexpensive gateways operated by independent business enterprises all operating through the satellite under centralized control nearly eliminates the need for long-distance wireline interconnections.

4.10.3.3 System Financing and Development

The land mobile satellite system will require a large investment. It is likely that the first implementation will employ satellites built with current technology. As demands for the services grow and larger capacity spacecraft are needed, advanced technology spacecraft will be required. Two important institutions are essential to the implementation and development — the financial and corporate structure that will fund, build, and operate the system and the government-aerospace team that will develop the new technology that will enable the later versions of the system to meet the demands for services. NASA will play an important role in the development of space technology, particularly in large space structures and spacecraft power systems.

Appendix A

SATELLITE MOBILE SIGNAL PROPAGATION

Radio propagation between satellites and mobiles is significantly different from propagation between mobiles and terrestrial base stations. The deep Rayleigh fading that cannot be avoided on the terrestrial links can be reduced to insignificance on the satellite links by proper design of the mobile antenna. Signal strength is within a few dB throughout a satellite beam footprint; thus dynamic range of the signals is small compared to the dynamic range experienced as a mobile changes its range from a terrestrial base station. Signal blockage due to hills and mountains is less for satellites than for terrestrial links because the satellite is at a high elevation angle. Communications between the satellite and mobile are always direct line-of-sight. If the path is clear, communications are reliable. If the path is obstructed, the signals are completely blocked.

Major impairments in the satellite-mobile signal path are the following:

- Signal blocking by structures and terrain features
- Foliage attenuation
- Ionospheric scintillation
- Group delay in the ionosphere
- Multipath reflections at low elevation angles

Space loss, the reduction in signal level due to the spreading of the signal energy as the signal propagates through space, is given by:

$$\text{Loss (dB)} = 37 + 20 \log_{10} D + 20 \log_{10} f$$

Where: D = distance in statute miles

f = frequency in MHz

Space loss is thus about 183 dB in the 800 - 900 MHz band contemplated for the mobile radio satellite. If the satellite effective radiated power (ERP) were one watt, and the mobile antenna gain were 0 dB, the power received from the satellite would be -183 dB below one watt (-183 dBW). The signal strength is increased by the increase in transmitter power and by the sum of the increased gains of the satellite and mobile antennas. Signal impairments reduce the signal levels except for brief, small increases during scintillation fades.

When a structure or terrain feature, a building or hill, is directly in the path between the satellite and a mobile, the signal is attenuated severely. It is not feasible to provide enough signal margin to permit communications by reflections from other structures or terrain features in the area, which is the practice in terrestrial mobile communications. There may be some diffraction around the edges of buildings or over the tops of hills, but the effect is not significant for the satellite links. Experiments with the ATS-6 satellite at L-band (1550 - 1650 MHz) disclosed that even the trunk of a large tree would cast a sharp shadow for the signal from the satellite.

A practical way to estimate the areas that are blocked by structures and terrain features is to observe the shadows on a bright sunny day at a time when the sun is near the azimuth and elevation angles that the satellite would have. Where there is direct sunlight, communication with the satellite would be good; where there are shadows the signals would be blocked. Satellite azimuth would be a little west of south for the eastern states and a little east of south for the western states. Elevation would be about 30 degrees in Maine and 60 degrees in Tex-

as with intermediate elevations in other parts of the contiguous states.

Building penetration is desired for some applications, such as paging and law enforcement. In the 800 - 900 MHz band building attenuation is typically 20 to 30 dB. Terrestrial paging services and local police radio systems have adequate power density in their service areas to penetrate most buildings. It is not feasible to provide sufficient power density on the earth from a geostationary satellite to achieve direct building penetration. A nationwide paging service using satellites would require local terrestrial repeaters to relay the paging signals into the buildings. A paging service with direct satellite-to-paging-receiver may be feasible if building penetration is not required.

The power density of a satellite signal is compared with the power density of a typical terrestrial paging service. The much greater power density of the terrestrial service is sufficient to overcome the building attenuation and produce a detectable signal in the paging receiver while the satellite signal is inadequate.

For the terrestrial service:

| | |
|--|-------------------------------------|
| Range, paging transmitter to receiver: | 15 kilometers |
| Paging transmitter power: | 500 watts |
| Transmitter antenna gain: | 10 dB |
| Effective radiated power: | 5 kW |
| Power density outside building: | $1.77 \times 10^{-6} \text{ W/m}^2$ |

For the satellite signal:

| | |
|---------------------------------|-------------------------------------|
| Range, satellite to receiver: | 38,000 km |
| Satellite transmitter power: | 1 watt |
| Satellite antenna gain: | 50 dB |
| Effective radiated power: | 100 kW |
| Power density outside building: | $5.4 \times 10^{-12} \text{ W/m}^2$ |

In this example, the power density from the terrestrial transmitter is thus $.29 \times 10^6$ or 54.6 dB greater than the satellite signal.

The satellite signal level outside the building is sufficiently strong to be received by the paging receiver, as shown by the following simplified power budget.

| | |
|-----------------------------------|-------------|
| Space attenuation, 38,000 km: | -183 dB |
| Satellite transmit power: | 0 dBW |
| Satellite antenna gain: | 50 dB |
| Paging receiver antenna gain: | -10 dB |
| Received signal power: | -143 dBW |
| Receiver noise power density: | -194 dBW/Hz |
| Receiver C/N_0 : | 51 dB Hz |
| Noise bandwidth factor: (10 kHz): | 40 dB |
| Carrier to noise ratio: | 11 dB |

While there is sufficient signal to receive the satellite signal outside the building, there is not a sufficient margin to overcome the 20 to 30 dB building attenuation.

Foliage attenuation is severe in the 800-900 MHz band. The branches of dry, dormant deciduous trees without leaves may not attenuate signals sufficiently to block communications, but when the trees are wet or in leaf they will almost certainly block satellite signals when they are in the direct path. Elevation angles to satellites are higher than the elevation angles to tower mounted terrestrial radio transmitter-receivers. The probability that foliage is in the signal path is less for the satellite than for the terrestrial links, although the advantage may be offset somewhat by the larger fade margin on the terrestrial links.

Foliage attenuation may be avoided on the satellite links by moving the mobile out from under a tree or to a spot in a forest where an opening in the canopy clears the path to the satellite. Communications may be unsatisfactory when in motion along a road lined with trees close to the road on the side toward the satellite.

Data on foliage attenuation are available in the literature, but none is presented here because the effect is so severe on satellite links that foliage should be considered a complete block to the signals in the same way as structure and terrain feature blocking. When foliage is in the direct path, the signals are almost certain to be blocked. When it is not present, communications are reliable.

Ionospheric scintillation is an occasional cause of fading on signals passing through the ionosphere between satellites and the earth. The scintillation is caused by irregularities in the horizontal distribution of free electrons in the ionosphere. They cause the signal ray paths to be bent, thus focussing energy toward, then away from a point on the earth as the irregularities move. Figure A-1 illustrates the mechanism.

A fading episode may start suddenly, last a few minutes or a few hours, and stop suddenly. Occurrences are less frequent at mid latitudes near the magnetic poles and magnetic equator. The rate of occurrence is greater during the peak of the eleven year sunspot cycle than during the years of few sunspots. Fading is more likely to occur near local midnight than at other times of day, but it may happen at any time.

The magnitude of the fading is greater at lower frequencies than at higher frequencies. At VHF, a few hundred MHz, the signal may vary from a few dB above the undisturbed signal level to 30 or more below the undisturbed level. Deep fades are usually of short duration — a fraction of a second — although periods of reduced signal level lasting for several minutes have been attributed to ionospheric scintillation.

Fading amplitude is less at higher frequencies, but it has been observed at C-band, 4-6 GHz.⁽¹⁾ Fang and Pontes summarize the gross features of 4/6-GHz ionospheric scintillation as follows:

1. Scintillations occur in the geomagnetic equatorial region, mainly between 30 degrees magnetic north and 30 degrees geomagnetic south and expand and contract as solar activities increase and decrease, respectively.
2. The frequency of occurrence of scintillation events has strong diurnal peaks. The probability of occurrence is greatest about one hour after local ionospheric sunset, and scintillations may last for hours until midnight.
3. The frequency of occurrence varies by season, with peak activity around vernal equinox and high activity at autumnal equinox.
4. An f^{-s} relationship with s between 1.5 and 2.0 exists between the 4 and 6 GHz scintillation amplitudes.
5. The power spectral densities of the scintillation generally exhibit a power law frequency dependence for spectral frequencies greater than the Fresnel frequency. An f^{-3} asymptotic frequency dependence can be considered reasonable for most weak scintillation events.
6. All these features have annual variations related to the 11-year sunspot cycles.

⁽¹⁾ Fang, D.J. and Pontes, M.S. "4/6-GHz Ionospheric Scintillation Measurements During the Peak of Sunspot Cycle 21," *Comsat Technical Journal*, Vol. 11, No. 1, Fall 1981.

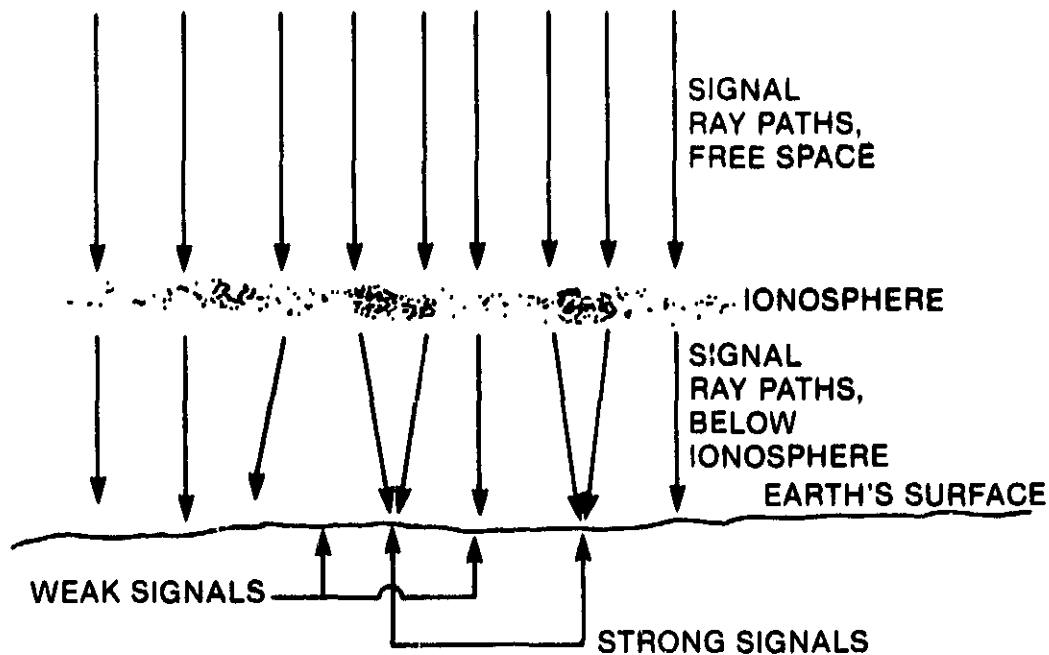

AS DENSER REGIONS IN IONOSPHERE
MOVE HORIZONTALLY, THE SIGNAL LEVEL VARIES (FADES)
AT A POINT ON THE EARTH

Figure A-1. Cause of ionospheric scintillation

Annual statistics of ionospheric scintillation at Hong Kong, latitude 22 12'N, geomagnetic latitude 10.52 N, are presented in Figure A-2, courtesy of Dr. Fang. POR refers to the Pacific Ocean region, served by satellite INTELSAT IV F8 at 174 E. IOR refers to the Indian Ocean region served by satellite INTELSAT IV-A F1 at 63 E. SSN is sunspot number. Note that the peak of the sunspot cycle occurred in the 1979-1980 period.

The data presented by Fang and Pontes does not apply directly to the 800-900 MHz band and to the more northerly latitudes of the United States. The geomagnetic latitude of the contiguous states is from 40° N to 60° N.

The data are presented here to show the temporal pattern of scintillation occurrence, and the general nature of the phenomenon. The frequency of occurrence is less at the geomagnetic latitudes of the contiguous states, but the magnitude of the fading is greater at 800-900 MHz than it is at 4/6 GHz. While the effect will be noticed occasionally in an operations mobile satellite system, it will not have a major effect on signal reliability.

Group delay in the ionosphere refers to the additional time it takes for a signal to arrive at the earth from a satellite because the radio waves travel more slowly through the ionosphere than they travel in free space or in the lower atmosphere. Group delay has no significant effect on narrow band communication signals, but it results in range errors when the signals are used for position fixing by ranging methods. Group delay can cause distortion of wide band communication signals if the delay is different for the upper and lower sidebands of the signals.

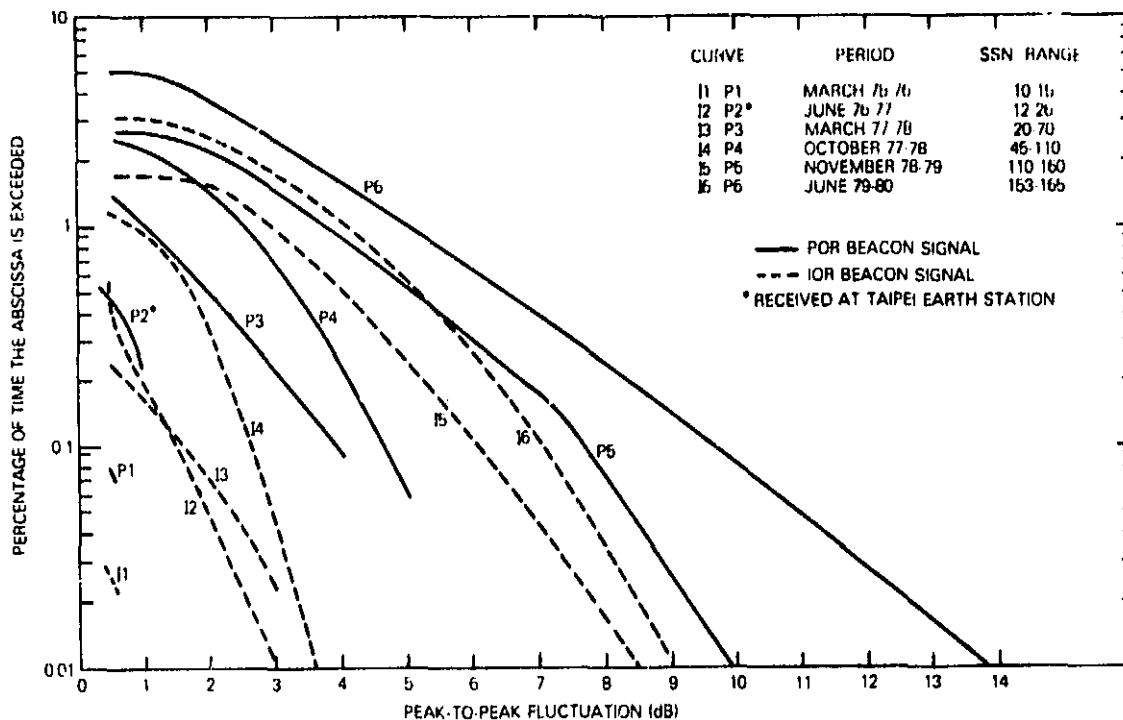

Figure A-2. Annual statistics of ionospheric scintillations at Hong Kong earth station

Millman (2) states the "presence of the ionosphere introduces an increase in the effective group path length relative to free space and that, for frequencies in the VHF range and above, the one-way range increase (in centimeters) can be expressed, as a first approximation, by the function

$$\Delta R_g = \frac{40 \times 10^6}{f^2} \int_0^s N_e ds$$

where the frequency, f , is in cycles/sec and the integrated electron density is in electrons/cm³

Note that the amount of the range error varies inversely with the square of frequency. Figure A-3 presents typical one-way range errors at 100 and 200 MHz as a function of elevation angle to the satellite. The range error is reduced by a factor of 16 at 800 MHz relative to the delay at 200 MHz. The amount of the delay changes with time of day, season of year, the eleven year sunspot cycle and with solar disturbances. It is usually possible to predict the amount of group delay to within about one fourth of the actual group delay, hence to correct range measurements to about one fourth the error introduced by the ionosphere.

General Electric (3) presents the effects of the ionosphere on range measurements from NASA's ATS-3 satellite to transponders at Gander, Newfoundland; Shannon, Ireland; Reykjavik, Iceland; Thule, Greenland; Buenos Aires, Argentina; and Schenectady, N. Y. An example is Figure A-4 which shows the difference in measured minus computed slant range

(2) Millman, G. H., "A Survey of Tropospheric, Ionospheric, and Extraterrestrial Effects on Radio Propagation Between the Earth and Space Vehicles" NATO-AGARD Symposium on "Propagation Factors in Space Communications," Rome, Italy, September 21-25, 1965. General Electric Co. Report TIS R66EM11.

(3) "Final Report on Phases 1 and 2 VHF Ranging and Position Fixing Experiment Using ATS Satellites" 25 November 1968 - 1 May 1971. Contract No. NAS5-11634 General Electric Report S-71-1109.

ONE-WAY RANGE BIAS DUE TO TROPOSPHERIC AND IONOSPHERIC RETARDATION

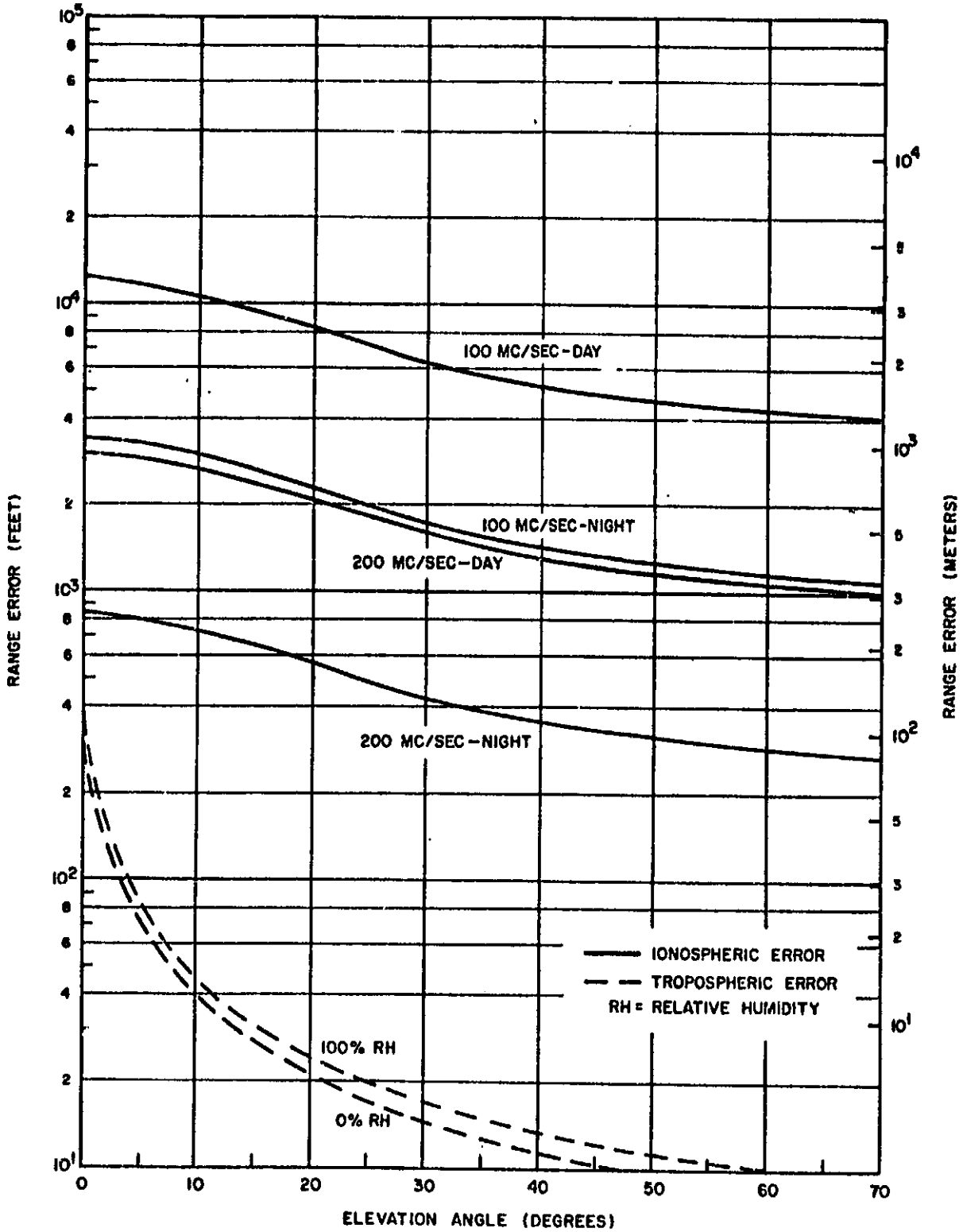

Figure A-3. One-way range bias due to tropospheric and ionospheric retardation.

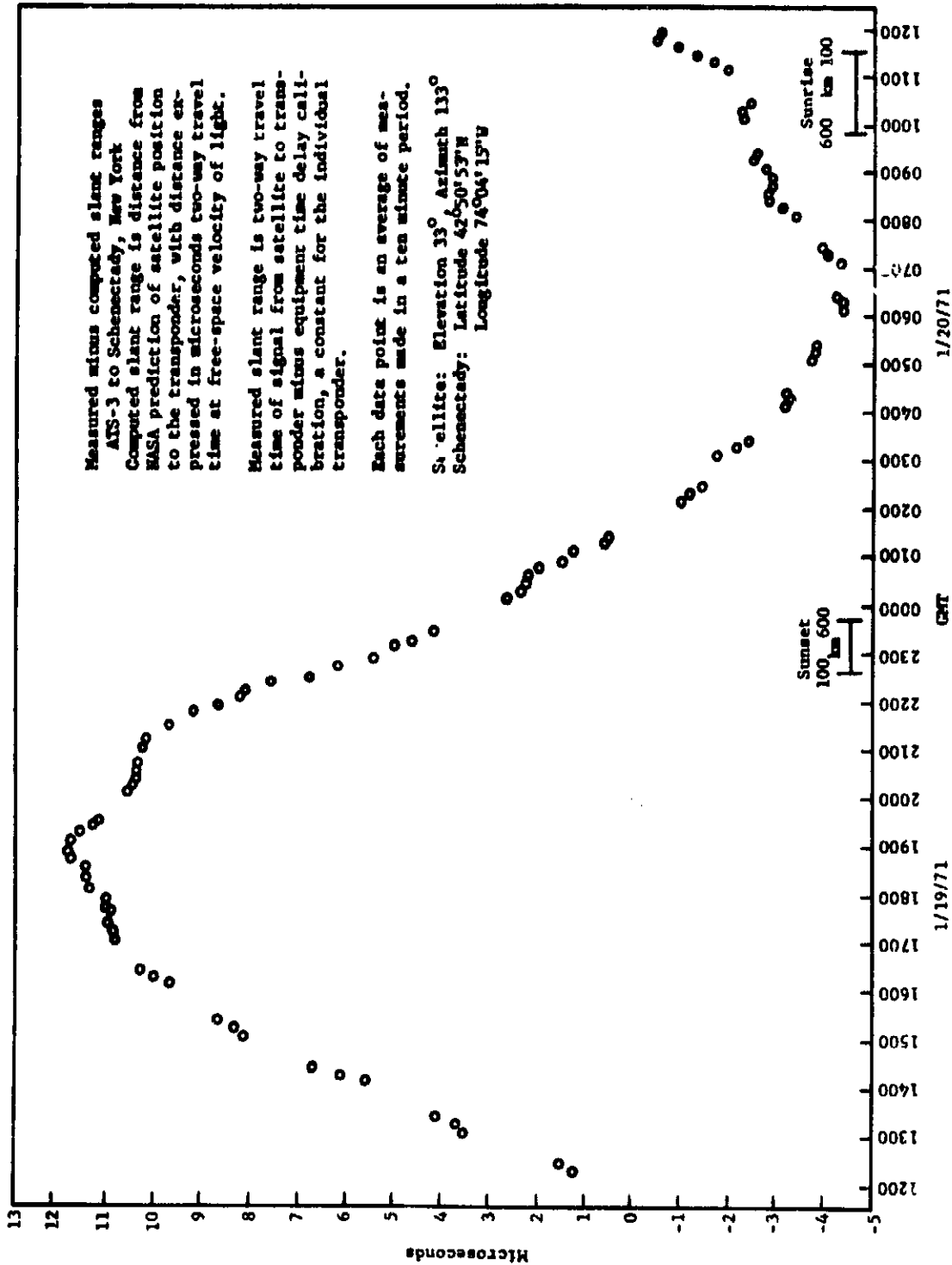

Figure A-4. Difference in measured minus computed slant range from ATS-3 satellite to Schenectady during a 24-hour period

from the satellite to Schenectady during a 24 hour period. The measurements were made through the VHF transponder of the satellite with an uplink frequency of 149 MHz and a downlink frequency of 135 MHz.

The effects of the earth's troposphere and ionosphere on satellite-earth signal paths are summarized in Table A-1.

Multipath reflections at low elevation angles to the satellite can result in serious degradation of the signals. When the satellite is so near the horizon that the ground as well as the satellite is within the beam of the ground station or mobile antenna, the ground reflection and direct signal can interfere in the same way the ground reflections interfere in terrestrial systems. A moving vehicle is subject to Rician or Rayleigh fading.

A stationary vehicle may find the signal level weaker or stronger than it would be if the ground reflection were not present. It is stronger if the direct and reflected signal carriers are in phase, weaker if they are not in phase. If a single ground reflection is dominant, i.e., there are no significant reflections from nearby structures or terrain features, the interference pattern has a Fresnel zone characteristic in the surrounding space. A received signal may be changed from weak to strong by raising the antenna or moving it horizontally so that the difference in path lengths for the direct and reflected signals is changed by one half wavelength. At UHF the distance that it must be raised or moved is thus only a fraction of a meter.

If the transmit and receive frequencies are widely separated, the Fresnel zone patterns are different for transmit and receive, and the position selected for a common antenna on the basis of the received signal could be wrong for transmissions to the satellite. Frequency separations contemplated for land mobile transmit and receive bands, typically less than ten percent of the carrier frequencies, would usually provide a good transmission path if a good receive path is selected by maximizing the received signal.

Geostationary satellites are not truly geostationary. While the distances they move may not subtend large angles as viewed from the earth, their diurnal excursions from their nominal positions may be many miles. As a land mobile satellite moves, the relative path lengths of the direct and reflected signals change and the signal into a stationary vehicle antenna changes from strong to weak. The change is not rapid, the strong signal usually persisting for a period of minutes so that a message exchange is possible before a readjustment of the antenna height is required.

Elevation angles to a land mobile satellite for the contiguous United States, Hawaii, and southern Alaska are sufficiently high to avoid the multipath reflection problem by suitable design of the mobile antenna. The problem cannot be avoided in northern Alaska. The mobile satellite communications in northern Alaska may be conducted by stopping the vehicle and adjusting its position either by moving it back and forth to a spot where the satellite signal is strong or by adjusting the height of the antenna. An understanding of the problem and its solution may be gained by listening to an FM broadcasting station on a car radio in a weak signal area. The car, stopped at one spot, may receive a noisy signal or no signal at all. Moving to another spot a few meters distant can result in clear reception.

Table A-1
TROPOSPHERIC AND IONOSPHERIC PROPAGATION EFFECTS

| EFFECTS | MATHEMATICAL DESCRIPTIONS | DEFINITION OF TERMS & COMMENTS |
|-------------------------------------|--|---|
| Tropospheric Refraction | $(n - 1) \times 10^6 = \frac{p}{T} \left(p + \frac{bc}{T} \right)$ | n = refractive index T = air temperature (°K) p = total pressure (millibars) c = partial pressure of water vapor (millibars) Note: Refraction is frequency independent |
| Ionospheric Refraction | $n = 1 - \left[\frac{4\pi N_e e^2}{m^2 \omega^2} \right]^{1/2}$ | n = refractive index N _e = number of electrons/cm ³ e = electron charge (4.8 × 10 ⁻¹⁰ esu) m = electron mass (9.1 × 10 ⁻³¹ gm) ω = angular frequency of incident waves (radians/second) |
| Ionospheric Attenuation | $A = \frac{1.17 \times 10^{-12}}{f^2} \int N_e \nu da$ | f = frequency (cps) N _e = electrons/cm ³ da = path differential (cm) ν = electron collision frequency (collisions/sec.) |
| Ionospheric Polarisation Rotation | $\varphi = \frac{2.302 \times 10^4}{f^2} \int_0^h f(h) H \cos \theta N_e dh$ | φ = angular rotation H = magnetic field intensity (gauss) f(h) = secant of angle between ray path and zenith dh = height differential (cm) θ = angle between magnetic lines and propagation path |
| Ionospheric Dispersion | $\Delta\varphi = \frac{40 \times 10^4}{c f} \int_0^h N_e df$ | Δφ = differential phase shifts (in cycles) for CW transmissions of frequency separation f _s f = average of the two transmitted frequencies (cps) The integral is the integrated electron density along the path (electrons/cm³). |
| Angle of Arrival Scintillation | $\overline{\theta^2} = \frac{2 \times 10^{-12} \sqrt{L} \sqrt{1 - N^2}}{L}$ Angle of Arrival for a Turbulent Troposphere | $\overline{\theta^2}$ = mean squared angle of arrival L = path length through turbulence L ₀ = scale length of the turbulence eddy 1/N ² = mean square fluctuations in the refractivity, N |
| Tropospheric Phase Scintillation | $\overline{\Delta\varphi^2} = \frac{8 \times 10^{12} n^2 L \sqrt{1 - N^2}}{V}$ | $\overline{\Delta\varphi^2}$ = mean square phase fluctuations Note: Typical values for 100 Kilometer path length • 1000 MHz: $(\overline{\Delta\varphi^2})^{1/2} \approx 2^\circ$ • 100 MHz: $(\overline{\Delta\varphi^2})^{1/2} \approx 0.2^\circ$ |
| Ionospheric Phase Scintillation | $\overline{\Delta\varphi^2} = \frac{L_0 L \omega^2}{4 c^2 \omega^2} \left(\frac{\Delta N_e}{N_e} \right)^2$ | $\frac{\omega^2}{c}$ = angular plasma frequency c = speed of light $\left(\frac{\Delta N_e}{N_e} \right)^2$ = mean square fractional deviation of electron density Note: Typical values for 100 Kilometer path length at 100 MHz is 1.0° |
| Amplitude Scintillation | $\left(\frac{\Delta A}{A} \right)^2 = \frac{\pi^2 \omega^2 L_0 \omega^2}{4 c^2 \omega^2} \left(\frac{\Delta N_e}{N_e} \right)^2$ or $\left(\frac{\Delta A}{A} \right)^2 = \left(\frac{2\pi \omega}{L_0 \omega} \right)^2 \overline{\Delta\varphi^2}$ | $\left(\frac{\Delta A}{A} \right)^2$ = mean square fractional deviation of amplitude of signal from infinite distance where ΔA and A are the amplitude deviation and mean amplitude of the resultant signal. Z = distance of ionospheric scatters from the ground |
| Tropospheric Time Delay | | Independent of frequency. Maximum range error of 100 feet at sea level. Effect negligible in jet aircraft altitude. |
| Ionospheric Time Delay | $\Delta R_R = \frac{40 \times 10^4}{f} \int_0^h N_e ds$ | ΔR _R = one way range increase (cm) |
| Tropospheric Doppler Shift Error | $\Delta f_d = -\frac{f}{c} \Delta E_T V \sin \theta$ where $\Delta E_T = \cos^{-1} \left[\frac{r_0}{r_0 + h} \cos (E - \delta E) \right]$ $-\cos^{-1} \left[\frac{n_T r_0}{n_T (r_0 + h)} \cos E \right]$ | Δf _d = additional doppler shift over free-space doppler caused by troposphere V = velocity of moving object c = free-space velocity of propagation ΔE _T = angle defined by second equation (radians) n _G = refractive index at the ground n _T = refractive index at the space vehicle r ₀ = earth radius δE = refraction angle error at elevation angle, E, and height, h |
| Ionospheric Doppler Frequency Error | $\Delta f_d = -\frac{40 \times 10^4}{c f} \frac{d}{dt} \int_0^h N_e ds$ | Δf _d = additional doppler shift over free-space doppler caused by the ionosphere |

Appendix B

EXPERIMENTAL VERIFICATION OF TERRESTRIAL AND SATELLITE PROPAGATION CHARACTERISTICS

Terrestrial and satellite signal paths are significantly different. Terrestrial signals are plagued by multipath reflections and obstructions. They are also affected by large signal level changes as the relative distance changes between the mobile and the base or other mobiles. Satellite signals are essentially free space paths with nearly constant signal levels provided that the satellite is above an elevation angle such that vehicle antenna pattern can minimize ground reflections. The satellite signals are blocked by objects in the direct path.

Figure B-1 is a comparison of satellite relayed signals and 150 MHz terrestrial land mobile signals. Signal level changes of the land mobile signal are in excess of 20 dB. At 800 MHz the pattern would be similar except that the fading rate would be higher in proportion to the shorter wavelength. Fading rate is proportional to vehicle velocity and is affected by its direction of motion relative to the receiver.

The satellite signal was received at the General Electric Earth Station Laboratory via NASA's ATS-6 satellite from a truck like the one shown in Figure B-2. The satellite antenna is the two centimeter diameter, 70 cm tall antenna on the front of the truck cab. The antenna pattern is omnidirectional in azimuth and has a vertical pattern from 4 degrees to 19 degrees elevation for reception and from 11 degrees to 28 degrees for transmission between the -3 dB points. The linearly polarized antenna had a maximum gain of 7.3 dB, a net gain of 4.3 dB when used with the circularly polarized satellite. The truck transmitter power was 12 watts at L-band (1550 MHz). Elevation angles to the satellite were between 13 degrees and 19 degrees as the trucks travelled on their routes throughout the northeastern quarter of the contiguous states.

Five trucks in routine service engaged in the experiment over a period of seven months. The voice communications were between the drivers and Company dispatchers at Staunton, Virginia. The signals were relayed by the satellite to General Electric's Earth Station Laboratory near Schenectady, New York, then simultaneously back through the same transponder on another channel of the satellite for a double hop simplex link. The satellite, with its 10 meter diameter antenna and 34 watts of transmitter power, had the capacity to relay a number of the truck signals simultaneously.

The satellite signal recording of Figure B-1 is typical of all the signals during the long experiment. Overpasses and other obstructions blocked the signal completely but briefly. Table B-1 shows the received signal-to-noise ratios in the trucks and at the Earth Station Laboratory. The received signals in the trucks were stronger than those at the Earth Station Laboratory where the recording of Figure B-1 was made.

The effects of signal blockage are shown in Table B-2. Signal blockage would be less if the satellite were at a higher elevation angle. The Southern Piedmont region was outside the -3 dB contour of the satellite beam footprint. None of the ionospheric impairments described above had any identified effects on the truck communications.

The truck experiment was one of a long series of experiments with land, sea and air mobiles that measured and confirmed the propagation characteristics of satellite mobile communications. The following is a partial list of publications describing experiments with NASA's ATS satellite.

Anderson, R. E., Frey, R. L., Lewis, J. R. and Milton, R. T., "Satellite-Aided Mobile Communications: Experiments, Applications, and Prospects." IEEE Tran-

sactions on Vehicular Technology, Vol. VT-30, No. 2, May 1981.

Brisken, A. F., Anderson, R. E., Frey, R. L. and Lewis, J. R., "Land Mobile Communications and Position Fixing Using Satellites," IEEE Transactions on Vehicular Technology, Vol. VT-28, No. 3, Aug. 1979.

Anderson, R. E., "Communications and Position Fixing Experiments Using the ATS Satellites," Navigation, Vol. 20, No. 4, Winter 1973-1974.

"Communications Equipment for Alphanumeric Communications Via ATS-3 Satellite," Final Report on NASA Contract NAS2-10764 Prepared by General Electric Company, Prepared for National Aeronautics and Space Administration Ames Research Center, Moffett Field, CA. June 1982.

"Satellite-Aided Mobile Communications Limited Operational Test in the Trucking Industry," Final Report on NASA Contract NAS5-24365, Prepared by General Electric Company, Prepared for National Aeronautics and Space Administration Goddard Space Flight Center, Greenbelt, MD. July 1980.

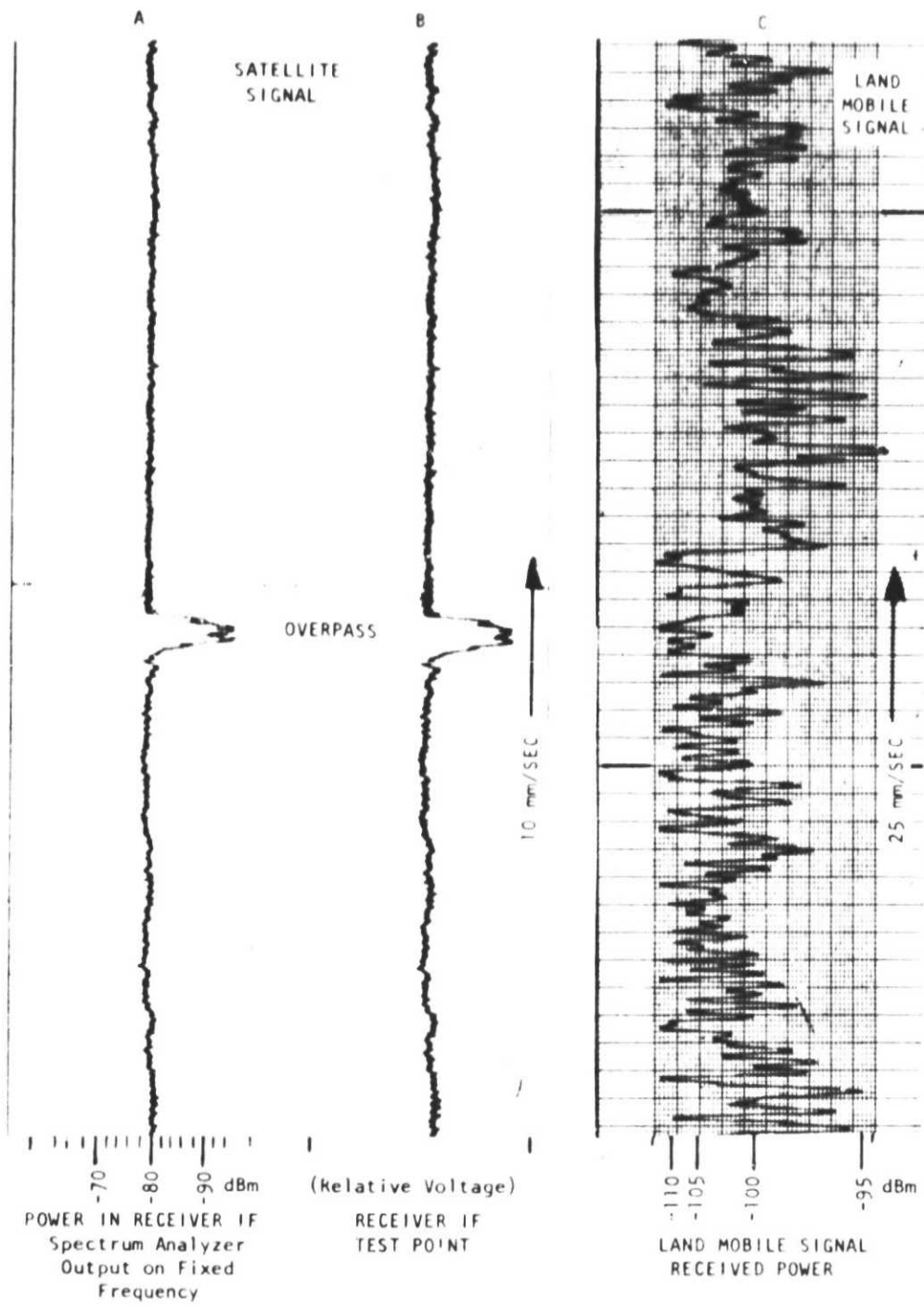

Figure B-1. Comparison of satellite relayed signals and 150 MHz terrestrial land mobile signals



Figure B-2. Truck equipped with mobile radio

Table B-1
TRUCKS AND BASE STATION

| TRUCKS AND BASE STATION | | | |
|-------------------------------|------------------------------|---------------------|-----------------------------|
| <u>TRANSMIT FREQUENCY</u> | <u>RECEIVE FREQUENCY</u> | <u>I.F. S/N</u> | <u>AUDIO OUTPUT S/N</u> |
| 1655.050 MHz | 1552.000 MHz | 26 dB | 30 dB |
| FARTH STATION LABORATORY | | | |
| <u>TRANSMIT FREQUENCY</u> | <u>RECEIVE FREQUENCY</u> | <u>I.F. S/N</u> | <u>AUDIO OUTPUT S/N</u> |
| 1652.010 MHz | 1550.050 MHz | 18 dB | 24 dB |

ORIGINAL PAGE
BLACK AND WHITE PHOTOGRAPH

Table B-2

TRUCK SIGNALS RECEIVED AT EARTH STATION LABORATORY
 (poorest link, signals better in truck, see Table B-1)

| TRUCK LOCATION | APPROXIMATE ELEVATION | TOTAL TIME ON (SECONDS) | Q4, Q5 SECONDS, PERCENT | Q3-Q1 (SECONDS) | | | |
|-------------------------------|-----------------------|-------------------------|-------------------------|-----------------|-----------|-------|-------|
| | | | | OVERPASS | MOUNTAINS | TREES | OTHER |
| Open Plains | 13° | 2481 | 2407 (97) | 35 | 8 | 2 | 29 |
| Appalachian Western Foothills | 15° | 344 | 313 (91) | 0 | 31 | 0 | 0 |
| Appalachian Mountains | 14° | 1037 | 881 (85) | 9 | 88 | 59 | 0 |
| Eastern Piedmont | 13° | 1219 | 1107 (91) | 9 | 51 | 39 | 13 |
| Southern Piedmont* | 18° | 279 | 153 (55) | 2 | 0 | 124 | 0 |

* Near satellite beam edge

SIGNAL QUALITY DEFINITIONS

- Q5 Clearly understood, no perceptible noise
- Q4 Clearly understood, perceptible noise
- Q3 Mostly understood, noisy
- Q2 Poorly understood, much noise
- Q1 Signal present, not understood

Appendix C

COMMENTS BY COMSAT ON INSTITUTIONAL CONSIDERATIONS

Fredrick L. Hofmann

We have reviewed the draft of the Regulatory Aspects section of the final report prepared by GE, and agree with the observations and findings. The attached report contains our additional comments.

INSTITUTIONAL

Institutional considerations for providing land mobile satellite services range from full government ownership to private ownership providing a full range of communication services. While NASA has historically advanced satellite communication techniques through hardware development and demonstration, government ownership of an operating commercial service has never been a serious consideration. Neither does it follow the trend toward commercialization of many functions which are presently performed by government agencies.

The majority of domestic satellite systems operating today providing specialized services are owned by private companies and operated competitively. In the land mobile satellite case this would equate to private ownership of the space segment by a company which would sell services to mobile users and provide interconnection into the public switched network. It has been shown that such a system can be designed to be compatible with a cellular mobile system and provide first priority for call completion through the terrestrial system. Even so, a system owned and operated in this manner will be perceived as competitive by wireline and RCC companies, vying, if not directly for customers, then for spectrum. It is evident that today the terrestrial cellular and mobile services enjoy the first priority for bandwidth and make it difficult to justify reservation of adequate and appropriate spectrum for future land mobile satellite systems.

An alternative approach would have private ownership of the space segment, but the entire capacity leased or provided on a wholesale basis to one or more retail carriers. Advantages would include greater acceptance on the part of carriers (at least those who directly benefited) and a greater probability of working out acceptance allocation of spectrum as demand increases. This would also facilitate arrangements for providing interconnect between mobile units and the public switched network. Leasees might be permitted to share in the ownership of such a system.

A variation of this approach would be the case where several companies joined together, none of them with majority ownership, and operated the space segment for their own services on a shared revenue basis. This might prove the most advantageous approach in terms of insuring that economic land mobile satellite service matures in a reasonable time period, although it also would probably generate the greatest regulatory concerns and issues.

A question which may affect system design is related to the rates charged for services via satellite and via terrestrial circuits. Satellite communication costs are relatively distance-insensitive, while terrestrial costs are distance-dependent. Calls placed to or from a mobile unit may be routed via satellite or via terrestrial link, depending upon the vehicle location. If there is any substantial difference in rates, particularly in the case of long-distance calls, there may be attempts to circumvent the proposed system architecture where first priority for call placement would go through terrestrial circuits.

REGULATORY

Government deregulation and court-ordered divestitures in the communications industry are intended to permit competitive forces to operate to the benefit of the consuming public. Advantages can include more alternatives and reduced costs for goods and services. While these efforts are beneficial and have led to rapid changes in the communications industry, the danger is that an economically viable mobile satellite system could be precluded through premature and irrevocable assignment of spectrum for immediate uses. In the belief that the hybrid satellite and terrestrial mobile system has been studied sufficiently to determine its feasibility, then technical validation is warranted in the form of flight experiments such as the proposed MSAT program with Canada. In its recent petition to the FCC, NASA has asked for a minimum allocation, a total of 8 MHz in the 806-890 MHz band, which will permit early experiments in both public and private services with the MSAT program. NASA has requested that an additional 12 MHz of bandwidth be reserved for future allocation, which would be used when the land mobile satellite system concept is validated and an operational system planned. Even this may not be enough to permit an economically viable system.

The counter argument against retaining reserve bandwidth for the possible use of a land mobile satellite system is that this, and more, bandwidth will be needed to satisfy the needs of mobile cellular service. This argument is based upon the projected needs in the very largest metropolitan areas. The concern is that basing cellular mobile frequency allocation on one or a very few areas will leave much of the country with capacity that will never be required or used. The tradeoff that must be made is whether service in the few largest urban areas should be limited in favor of allocating spectrum to a satellite service which much more equally distributes the capacity over rural areas where it is needed. Despite the enthusiastic response for cellular licenses, it is quite probable that the growth in the number of cells installed in any one metropolitan area will be at a fairly slow rate. The high cost of starting up a new cellular system will in part dictate the growth rate. Little data is available on operating costs, and even less on the cost of expanding cellular systems once in place to later accommodate more subscribers by reducing, through subdivision, the size of an individual cell. If the cost to accommodate more subscribers through cell subdivision to established systems is prohibitively high, it will inhibit the desire of operators to subdivide, and hence restrict the addition of subscribers.

Until adequate operating experience is gained with mobile cellular systems, the options for allocation of reserve bandwidth in the 806-890 MHz band should be preserved. The pressing issue thus appears to be preventing an irrevocable allocation at this time.

| | | | |
|--|--------------------------------------|---|---------------------------------|
| 1. Report No CR-168064 | 2. Government Accession No. | 3. Recipient's Catalog No. | |
| 4. Title and Subtitle MOBILE RADIO ALTERNATIVE SYSTEMS STUDY SATELLITE/TERRESTRIAL (HYBRID) SYSTEMS CONCEPTS | | 5. Report Date June 1983 | 6. Performing Organization Code |
| | | 8. Performing Organization Report No 83SRD039 | 10. Work Unit No. |
| 7. Author(s) John D. Kiesling, Space Systems Division Roy E. Anderson, Corporate Research and Development | | 11. Contract or Grant No NAS3-23244 | |
| | | 13. Type of Report and Period Covered | |
| 9. Performing Organization Name and Address General Electric Company Corporate Research and Development Space Systems Division Schenectady, New York Philadelphia, Pennsylvania | | 14. Sponsoring Agency Code | |
| | | 12. Sponsoring Agency Name and Address NASA-Lewis Research Center Cleveland, Ohio | |
| 15. Supplementary Notes | | | |
| 16. Abstract <p>Volume I of the Mobile Radio Alternatives Systems Study describes the markets for mobile radio services in non-urban areas of the United States in the years from 1985 to 2000. This volume of the study report examines the use of satellite systems for satisfying the markets. Regulatory and insitutional aspects of land mobile satellites are also addressed.</p> <p>Several satellite concepts are considered: a system with single-beam coverage of the fifty United States and Puerto Rico and multi-beam satellites with greater capacity. All of the needed functions and services identified in the market study are provided by the satellite systems, including nationwide radio access to vehicles without knowledge of vehicle location, wideband data transmission from remote sites, two way exchange of short data and control messages between vehicles and dispatch or control centers, and automatic vehicle location (surveillance).</p> <p>The costs of providing the services are within acceptable limits, and the desired returns to the system investors are attractive.</p> <p>The criteria by which the Federal Communications Commission judges the competing demands for public radio spectrum are reviewed with comments on how the criteria might apply to the consideration of land mobile satellites. Institutional arrangements for operating a mobile satellite system are based on the present institutional arrangements in which the services are offered to the end users through wireline and radio common carriers, with direct access by large private and government users.</p> | | | |
| 17. Key Words (Suggested by Author(s)) Mobile radio communications, Mobile satellite communications, Mobile satellite systems concepts, Mobile satellite systems costs, Mobile satellite regulatory issues, Mobile satellite institutional issues | | 18. Distribution Statement | |
| 19. Security Classif. (of this report) none | 20. Security Classif. (of this page) | 21. No. of Pages | 22. Price* |

* For sale by the National Technical Information Service, Springfield, Virginia 22161