

NASA Technical Memorandum 84336

Nasa-TM-84336

NASA-TM-84336 19840003109

# Adaptive Inverse Control for Helicopter Vibration Reduction

Stephen A. Jacklin

September 1983

FOR REFERENCE

NOT TO BE TAKEN FROM THIS ROOM

LIBRARY COPY

NOV 18 1983

LANGLEY RESEARCH CENTER  
LIBRARY, NASA  
HAMPTON, VIRGINIA



National Aeronautics and  
Space Administration

---

# Adaptive Inverse Control for Helicopter Vibration Reduction

---

Stephen A. Jacklin, Ames Research Center, Moffett Field, California

**NASA**

National Aeronautics and  
Space Administration

**Ames Research Center**  
Moffett Field, California 94035

N84-11177#

## SUMMARY

The reduction or alleviation of helicopter vibration will reduce maintenance requirements while at the same time increase ride quality and helicopter reliability. In forward flight, the helicopter's fuselage vibration spectrum tends to be dominated by multiples of the "N/REV" component. This paper presents a way to use the method of adaptive inverse control to identify, in real-time, a controller capable of generating N/REV vibration of opposite phase to cancel the uncontrolled N/REV vibration component. The control considered in this paper will be that of multicyclic feathering of blade pitch.

## INTRODUCTION

In forward flight, asymmetrical airflow through the rotor disk of the helicopter produces a fuselage vibration spectrum which tends to be dominated by multiples of the N/REV component; where "N" is the number of blades in the rotor producing N cycles of vibration per rotor revolution. The N/REV helicopter vibration dynamics may be modeled in the locally linear sense as:

$$\Delta Z(j) = T(j)\Delta\theta(j) \quad (1)$$

Here,  $[Z(j)]$  is a  $(p \times 1)$  vector whose elements are the N/REV sine and cosine coefficients of the Fourier transform of data taken from fuselage accelerometers. The vector  $[\theta(j)]$  is an  $(m \times 1)$  vector whose elements are the selected sine and cosine coefficients of the higher harmonic blade pitch. The local linear model postulates that within a short time interval the changes in the harmonic coefficients of cyclic pitch are linearly related to the changes in the harmonic coefficients of vibration. The transfer matrix describing this linear relationship is "T."

One solution to the vibration control problem would be to identify T, find its inverse (for  $m = p$ ), and then form the optimal control as:

$$\Delta\theta(j)_{opt} = -[T(j)]^{-1}Z(j) \quad (2)$$

$Z(j)$  is the total sensed (measured) N/REV vibration. The vector  $\Delta\theta(j)$  is the change in multicyclic control necessary to induce a vibration component of opposite phase to cancel the sensed vibration. The minus sign thus signifies opposite phase.

Figure 1 shows this control system. This approach to vibration control is limited to transfer matrices which are square, as presented thus far, but can be easily generalized for the nonsquare case.

This paper presents the method of adaptive inverse control as a means to simultaneously identify the inverse of the transfer matrix and to find the vibration feedback gain matrix. This method uses the least mean square (LMS) algorithm of Widrow

and Hoff (ref. 1) to identify the inverse of the transfer matrix. Thereby, no inversion is required. Hence, the adaptive inverse control scheme is computationally very efficient.

## REGULATOR DESIGN WITH ADAPTIVE INVERSE CONTROL

In this paper, the LMS algorithm and the method of adaptive inverse control presented by Windrow, McCool, and Medoff (ref. 2) are extended to solve the multiple-input/multiple-output helicopter vibration control problem. The necessary input command to the controller in this case is a vector whose elements are the uncontrolled components of N/REV vibration, changed in sign. In this manner the feedback commands given to the controller represent the vibration desired to cancel.

The resultant controller arrangement is shown in figure 2. The controller has been placed after the plant to form an adaptation error vector. The commanded change in multicyclic pitch at step  $j$  is  $\Delta\theta(j)$ . Referring to figure 3, it is seen that when  $\Delta\theta(j)$  is inputted to the helicopter, a corresponding change in vibration,  $\Delta Z(j)$ , results:

$$\Delta Z(j) = [T(j)]\Delta\theta(j) \quad (3)$$

This  $\Delta Z(j)$  is subsequently multiplied by  $C$ , the controller matrix. If  $C$  is the inverse of the transfer matrix,  $T$ , then  $[C] * \Delta Z(j)$  should equal the original commanded change in pitch,  $\Delta\theta(j)$ . This is usually not quite equal to the original change in pitch because of errors in  $[C]$  identification and is thus denoted with a "hat" symbol,  $\Delta\hat{\theta}(j)$ .

$$\begin{aligned} \text{Adaptation Error} &= \Delta\theta(j) - \Delta\hat{\theta}(j) \\ e(j) &= \Delta\theta(j) - [C(j)]\Delta Z(j) \\ &= \Delta\theta(j) - [C(j)][T(j)][\Delta\theta(j)] \end{aligned} \quad (4)$$

Clearly, this error will be minimized when the controller matrix,  $C$ , is the inverse of  $T$ . This error vector is then used by the LMS algorithm in steepest descent form to update the estimate of the inverse transfer matrix,  $C$ . This algorithm is an iterative identification technique which makes changes in the  $C$  (inverse plant) matrix elements proportional to the gradient of the expected value of the mean square error signal with respect to the current estimate of  $C$ ,

$$C(j+1) = C(j) + k_s \nabla \{E[e(j)^2]\}$$

It will be shown that an unbiased estimate of this gradient is given by,

$$\nabla E[e_i^2(j)] = -2[\Delta\theta_i(j) - C_i^T(j)\Delta Z(j)]\Delta Z^T(j) \quad (5)$$

The steepest descent (LMS-SD) algorithm for calculating each row "i" of the controller matrix is then shown to be:

$$C_i^T(j+1) = C_i^T(j) - 2k_s[\Delta\theta_i(j) - C_i^T(j)\Delta Z(j)]\Delta Z^T(j) \quad (6)$$

## LMS ALGORITHM IMPLEMENTATION

The LMS algorithm (ref. 1) is the iterative estimation algorithm which we will use here to identify the inverse of the plant (helicopter) transfer matrix. In this section, the LMS algorithm and the method of adaptive inverse control presented by Widrow, McCool, and Medoff (ref. 2) will be extended to solve the multiple-input, multiple-output helicopter vibration control problem. This extension will be made by identifying the inverse transfer matrix in a row-by-row fashion. In this manner, the single weight vector originally LMS identified by Widrow and Hoff (ref. 1) now becomes a matrix of weights. The LMS algorithm will be adapted to make row-by-row corrections to the current row estimates of the inverse matrix. Using the "steepest descent" approach, these corrections will be made proportional to the gradient of the expected mean square estimation error vector, with respect to the current row estimate values. In this section we will define the terminology used and explain the meaning of the previous statement.

For each row "i" of the controller matrix at time step "j" we have:

$$e_i(j) = [\Delta_i \theta(j) - \Delta Z^T(j) C_i(j)] \quad (7)$$

and the square of this error as:

$$e_i^2(j) = [\Delta \theta_i(j) - C_i^T(j) \Delta Z(j)] [\Delta \theta_i(j) - \Delta Z^T(j) C_i(j)] \quad (8)$$

Here,  $\Delta \theta(j)$  is the  $i$ th element of the control vector fed into the helicopter plant (T).

The LMS algorithm is an iterative identification technique which makes changes in the C (inverse plant) matrix elements proportional to these estimation error signals. For each row of the controller matrix, the steepest descent update can be written as:

$$C_i^T(j+1) = C_i^T(j) + k_s \nabla \{E[e_i^2(j)]\} \quad (9)$$

This equation states that the current row estimate is equal to the previous value of the estimate plus a correction term. The correction term is zero when the identification error is zero.

" $E[e_i^2(j)]$ " denotes the "expected value" of the error squared, or the mean square error.  $\nabla \{E[e_i^2(j)]\}$  denotes the gradient of the mean square error signal with respect to the current estimate of C. That is,

$$\nabla \{E[e_i^2(j)]\} = \frac{\partial \{E[e_i^2(j)]\}}{\partial C(i,j)} \quad (10)$$

An expression of this gradient for the multiple-input, multiple-output (MIMO) case will be presented. Note that if the row error is large, a large change will be made to the row estimate of the inverse. If the error is small, a small change will be made. The stability constant,  $k_s$ , governs the stability and rate of convergence of this method, as will be shown.

The feature which makes the LMS algorithm so efficient is the elaborate manner in which the gradient of the mean square error is estimated. This method is now discussed in the context of identifying the inverse plant matrix,  $C$ . The gradient of the mean square error can be approximated for one time step (Ref. 1) as:

$$\nabla\{E[e_i^2(j)]\} = 2e_i(j)\nabla[e_i(j)] \quad (11)$$

Then by noting that the gradient of the error can be expressed as:

$$\begin{aligned} \nabla e_i(j) &= \nabla[\Delta\theta_i(j) - C_i^T(j)\Delta Z(j)] \\ &= -\Delta Z^T(j) \end{aligned} \quad (12)$$

we may express the gradient of the mean square error as:

$$\nabla[e_i^2(j)] = -2[\Delta\theta_i(j) - C_i^T(j)\Delta Z(j)]\Delta Z^T(j) \quad (13)$$

It is important to realize that in this expression  $\Delta\theta(j)$  is an  $(n \times 1)$  vector,  $\Delta Z^T(j)$  is a  $(1 \times m)$  vector, and hence the gradient is not a vector, but an  $(n \times m)$  matrix.

Although surprisingly simple in form, this approximation to the gradient is unbiased. To see this, we note that the square error (for each row  $i$ ) may be expressed as:

$$e_i^2(j) = \Delta\theta_i^2(j) - 2\Delta\theta_i(j)\Delta Z^T(j)C_i(j) + C_i^T(j)\Delta Z(j)\Delta Z^T(j)C_i(j) \quad (14)$$

The mean square error can then be found by taking the expected value of the error squared:

$$E[e_i^2(j)] = \overline{\Delta\theta_i^2(j)} - 2\phi_i^T(Z, \theta)C_i(j) + C_i^T(j)\phi(Z, Z)C_i(j) \quad (15)$$

where the covariance matrices have been defined as

$$\phi_i^T(Z, \theta) = E[\Delta\theta_i(j)\Delta Z^T(j)] \quad (16)$$

and

$$\phi(Z, Z) = E[\Delta Z(j)\Delta Z^T(j)] \quad (17)$$

If we now differentiate the expected value of the error squared with respect to  $C$ , we find that

$$\nabla\{E[e_i^2(j)]\} = -2\phi_i^T(Z, \theta) + 2C_i^T(j)\phi(Z, Z) \quad (18)$$

which is in agreement with the gradient estimate we had before:

$$\nabla[e_i^2(j)] = -2\Delta\theta_i(j)\Delta Z^T(j) + 2C_i^T(j)\Delta Z(j)\Delta Z^T(j) \quad (19)$$

Furthermore, by setting the gradient expression in equation (18) equal to zero, we see that each row of the C matrix should converge to the corresponding row of the inverse of T in an ordinary least squares sense:

$$\begin{aligned} C_i &= \Phi^{-1}(Z, Z)\Phi_i^T(Z, \theta) \\ &= [\Delta Z(j)\Delta Z^T(j)]^{-1}\Delta\theta_i(j)\Delta Z^T(j) \end{aligned} \quad (20)$$

as this is the same solution as would be obtained for the ordinary least square error solution.

Thus by using

$$\nabla[e_i^2(j)] = -2[\Delta\theta_i(j) - C_i^T(j)\Delta Z(j)]\Delta Z^T(j) \quad (21)$$

as the gradient estimate of the mean square error, the LMS-SD algorithm for each row "i" of the controller matrix is:

$$C_i^T(j+1) = C_i^T(j) - 2k_s[\Delta\theta_i(j) - C_i^T(j)\Delta Z(j)]\Delta Z^T(j) \quad (22)$$

Stability and rate of convergence are determined by the selection of the stability constant,  $k_s$ . Considerations governing the selection of  $k_s$  will now be discussed.

#### SELECTION OF STABILITY CONSTANT $k_s$ FOR ALGORITHM STABILITY AND CONVERGENCE

It has been shown thus far that we can find an unbiased estimate of the mean square error gradient for steepest descent utilization. The convergence properties of the steepest descent technique will now be discussed. Specifically, there is a need to know when the method can be guaranteed to converge to the true inverse of the plant, and how long it will take to do so. Our analysis will follow that of Widrow and Hoff (ref. 1) and will be extended to incorporate the helicopter (plant) inverse identification problem.

For each row (i) of the C (inverse plant) matrix the following difference equation was written for the method of steepest descent:

$$\begin{aligned} C_i^T(j+1) &= C_i^T(j) - 2k_s[\Delta\theta_i(j) - C_i^T(j)\Delta Z(j)]\Delta Z^T(j) \\ &= C_i^T(j) - 2k_s\Delta\theta_i(j)\Delta Z^T(j) + 2k_sC_i^T(j)\Delta Z(j)\Delta Z^T(j) \end{aligned} \quad (23)$$

Taking the expected value of both sides of this equation we get:

$$\begin{aligned}
E[C_i^T(j+1)] &= [I + 2k_s \Phi(Z,Z)] E[C_i^T(j)] - 2k_s \Phi_i^T(Z,\theta) \\
&= [I + 2k_s \Phi(Z,Z)]^{j+1} C(0) - 2k_s \sum_{i=0}^j [I + 2k_s \Phi(Z,Z)]^i \Phi_i^T(Z,\theta) \quad (24)
\end{aligned}$$

This equation can be put into modal form by writing the signal covariance matrix as

$$\Phi(Z,Z) = Q^{-1} \Lambda Q \quad (25)$$

where  $Q$  is the matrix composed of the eigenvectors of  $\Phi(Z,Z)$  and  $\Lambda$  is a diagonal matrix whose elements are the eigenvalues of  $\Phi(Z,Z)$ . Substituting this into the above equation yields:

$$\begin{aligned}
E[C_i^T(j+1)] &= [I + 2k_s Q^{-1} \Lambda Q]^{j+1} C_i(0) - 2k_s \sum_{i=0}^j (I + 2k_s Q^{-1} \Lambda Q)^i \Phi_i^T(Z,\theta) \\
& \quad (26)
\end{aligned}$$

$$E[C_i^T(j+1)] = Q^{-1} [I + 2k_s \Lambda]^{j+1} Q C_i^T(0) - 2k_s Q^{-1} \sum_{i=0}^j (I + 2k_s \Lambda)^i Q \Phi_i^T(Z,\theta)$$

From this we note that as long as the elements of

$$[I + 2k_s \Lambda]$$

are all less than one, then the term

$$Q^{-1} [I + 2k_s \Lambda]^{j+1} Q C_i^T(0)$$

will converge to zero, and the second term will converge to

$$\begin{aligned}
\lim_{j \rightarrow \infty} -2k_s Q^{-1} \sum_{i=0}^j [I + 2k_s \Lambda]^i Q \Phi_i^T(Z,\theta) &= -2k_s Q^{-1} \sum_{i=0}^{\infty} (I + 2k_s \Lambda)^i Q \Phi_i^T(Z,\theta) \\
&= -2k_s Q^{-1} \left[ \frac{1}{1 - (I + 2k_s \Lambda)} \right] Q \Phi_i^T(Z,\theta) \\
&= -2k_s Q^{-1} \left[ \frac{-1}{2k_s \Lambda} \right] Q \Phi_i^T(Z,\theta) \\
&= Q^{-1} \Lambda^{-1} Q \Phi_i^T(Z,\theta) \\
&= \Phi^{-1}(Z,Z) \Phi_i^T(Z,\theta) \\
&= C_{LMS} \quad (27)
\end{aligned}$$



Thus, for convergence to the correct solution by the method of steepest descent, we see that

$$|1 + 2k_s \lambda_{\max}| < 1 \quad (28)$$

$$\frac{-1}{\lambda_{\max}} < k_s < 0 \quad (29)$$

Within these limits, the value of  $k_s$  is selected with regard to the desired application. Values of  $k_s$  close to zero will be less apt to be affected by random noise variations on the plant at the expense of slow adaptation. Values of  $k_s$  near  $-1/\lambda_{\max}$  will adapt rapidly, but will be more prone to tracking random noise after "convergence" has been achieved, and will tend to oscillate about the correct solution. The right value of  $k_s$  is the one which converges at a sufficiently rapid rate, yet does not produce unacceptable steady state convergence errors. It is possible to make the value of  $k_s$  depend exponentially on the time step, but this will not be discussed here.

The rate of convergence may be thought of in terms of learning curve time constants,  $\tau$ . Letting  $r_p$  denote the geometric ratio of the  $p$ th mode, we can say that

$$r_p = (1 + 2k_s \lambda_p) \quad (30)$$

Then,

$$\begin{aligned} r_p &= \exp\left(-\frac{1}{\tau_p}\right) \\ &= 1 - \frac{1}{\tau_p} + \frac{1}{2! \tau_p \tau_p} - \dots \end{aligned} \quad (31)$$

or

$$\tau_p \approx \frac{1}{2k_s \lambda_p} \quad (32)$$

If all eigenvalues of  $\Phi(Z,Z)$  were the same, a single exponential learning curve could be defined. In the more general case, however, the eigenvalues will not be equal. Then the learning curve will be a function of all of the eigenvalues corresponding to the various normal modes. Thus, we can expect the fast modes to cause rapid initial learning, whereas the learning errors associated with the slower modes will take longer to die out and govern final convergence.

#### STARTING THE ADAPTIVE INVERSE VIBRATION CONTROL ALGORITHM: THE TRAINING PHASE

We have thus far established a method for iteratively correcting the estimate of the helicopter transfer matrix inverse. Yet, nothing has been said about initial conditions. At the start of the control routine, whether on the ground or in the air, a good starting value for the inverse of the helicopter transfer matrix may not

be known. Hence, a learning phase, termed the "training phase," is required at the start of the algorithm.

During the training phase, the blade pitch is given small perturbations and the corresponding changes in vibration are measured. These measurements are then used by the LMS-SD algorithm to correct an arbitrary initial value of the inverse plant matrix,  $C(0)$ . Any value of  $C(0)$  may be used — for example, all elements equal to zero. No vibration control commands are generated during the training phase. In this manner, large transients in control are avoided. Hopefully, after a number of iterations, the inverse plant matrix will be accurate enough to use in the actual control phase.

The control phase begins when the sum of squares of the adaptation errors,  $\Delta\theta - \widehat{\Delta\theta}$ , becomes small enough. No further training is then required. The LMS-SD algorithm will update the estimate of the plant inverse transfer matrix to keep up with changes in the plant (helicopter) or changes in the operating environment.

#### SIMULATION OF A THREE-INPUT, THREE-OUTPUT PLANT

The LMS-SD algorithm presented in this paper was simulated for a three-state plant. An arbitrary three-by-three transfer matrix,  $T$ , was chosen to represent the helicopter (fig. 4). The helicopter-vibration dynamics were then modeled in the global sense by the following equations:

$$\begin{bmatrix} Z_1(j) \\ Z_2(j) \\ Z_3(j) \end{bmatrix} = \begin{bmatrix} T_{11} & T_{12} & T_{13} \\ T_{21} & T_{22} & T_{23} \\ T_{31} & T_{32} & T_{33} \end{bmatrix} \begin{bmatrix} \theta_1(j) \\ \theta_2(j) \\ \theta_3(j) \end{bmatrix} + \begin{bmatrix} Z_1(0) \\ Z_2(0) \\ Z_3(0) \end{bmatrix} \quad (33)$$

Vibration at      Multicyclic control      Uncontrolled  
step  $k$                       input                      vibration

The LMS-SD update equations which identify the inverse plant transfer matrix (controller matrix) were then:

$$\begin{aligned} C_1^T(j+1) &= C_1^T(j) - 2k_s[\Delta\theta_1(j) - C_1^T(j)\Delta Z(j)]\Delta Z^T(j) \\ C_2^T(j+2) &= C_2^T(j) - 2k_s[\Delta\theta_2(j) - C_2^T(j)\Delta Z(j)]\Delta Z^T(j) \\ C_3^T(j+3) &= C_3^T(j) - 2k_s[\Delta\theta_3(j) - C_3^T(j)\Delta Z(j)]\Delta Z^T(j) \end{aligned} \quad (34)$$

And the vibration control commands were then generated by:

$$\begin{bmatrix} \theta_1(j+1) \\ \theta_2(j+1) \\ \theta_3(j+1) \end{bmatrix} = \begin{bmatrix} \theta_1(j) \\ \theta_2(j) \\ \theta_3(j) \end{bmatrix} - \begin{bmatrix} C_{11} & C_{12} & C_{13} \\ C_{21} & C_{22} & C_{23} \\ C_{31} & C_{32} & C_{33} \end{bmatrix} * \begin{bmatrix} \Delta Z_1(j) \\ \Delta Z_2(j) \\ \Delta Z_3(j) \end{bmatrix} \quad (35)$$

The simulation included both the training and the control phases. The effects of identification errors and changes in the operating conditions were also simulated. The overall program is diagrammed in figure 6.

From the preliminary simulation results, the LMS-SD algorithm appeared to provide a very robust control system. Figures 4 and 5 illustrate some of the interesting results obtained. Figure 4 illustrates the typical convergence pattern for  $k_S$  chosen near its midrange stability. Here the sum of the adaptation errors,  $\Delta\theta - \hat{\Delta\theta}$ , have been plotted versus the identification iteration cycle count. From this plot the normal modes of the system can be seen. Initial rapid convergence seemed to be produced by the fast modes, whereas final convergence appeared to be governed by the slower modes.

Figure 5 shows the behavior of LMS-SD convergence and vibration levels through the training and control phases. To simulate a sudden change in the operating conditions, the plant simulation values were suddenly changed by 20% and the uncontrolled vibration level was changed by 40%. The effect of these changes is shown in figure 5. The controller was able to respond in a manner to alleviate the vibration and a rather surprising feature of this robust control system was discovered.

The controller values did not have to converge exactly, or even very closely, to cancel the vibration. For example, figure 5 shows that after a step disturbance in the uncontrolled vibration level, the controller may retain steady-state identification errors, while rapidly alleviating the vibration. The explanation of this robustness rests in part upon the identification and control phases being iterative processes. As such, the proper change in blade-pitch control can be generated by a number of linear combinations of control changes over several steps. It turned out (in simulation) that when the controller matrix was sufficiently close to the true inverse, a linear feedback combination capable of alleviating most of the vibration was generated. When the vibration level approached zero, the pitch vector was no longer altered, thus preventing complete identification of the inverse. This was as it should be, since if there is no vibration, there is no need to change the pitch-control vector. The controller matrix can then no longer be altered since the update correction term (eq. (22)) goes to zero for no uncontrolled vibration. In actual implementation, however, random noise and perturbations would most likely allow complete convergence to the true inverse. The significant point though is that complete convergence is not required for good vibration control.

## CONCLUSIONS

The method of adaptive inverse control was presented in the context of helicopter vibration control. The theory used to derive the MIMO LMS-SD algorithm was given. Results of computer simulations of the inverse adaptation process were also presented and shown to indicate the validity of the results predicted by the theory. The conclusions verified by simulation were as follows:

1. The method of adaptive inverse vibration control can provide a very robust control system which does not require a perfect knowledge of the inverse plant matrix to alleviate vibration.
2. The "training phase" and the LMS-SD algorithm allows the method of adaptive inverse control to be implemented without any *a priori* knowledge of the plant. No

dynamic models are required, as the training phase can quickly determine proper controller initial conditions.

3. The LMS-SD algorithm is capable of adapting the controller to track changes in the flight conditions or changes in the uncontrolled vibration level. The controller converges quickly for moderate disturbance levels, while taking longer for larger (step) disturbances.

4. The learning curve of the controller during the training phase was shown to be quantitatively close to that predicted by the learning curves of the normal modes.

5. The method of adaptive inverse control should have very fast on-line capability, as implementation of the LMS-SD algorithm requires so few operations.

#### REFERENCES

1. Widrow, B.; and Hoff, M. E., Jr.: Adaptive Switching Circuits. IRE WESCON Conference Record, pt 4, 1960, pp. 96-104.
2. Widrow, B.; McCool, J.; and Medoff, B.: Adaptive Control by Inverse Modeling. 12th Asilomar Conference on Circuits, Systems, and Computers, Nov. 1978, pp. 90-94.

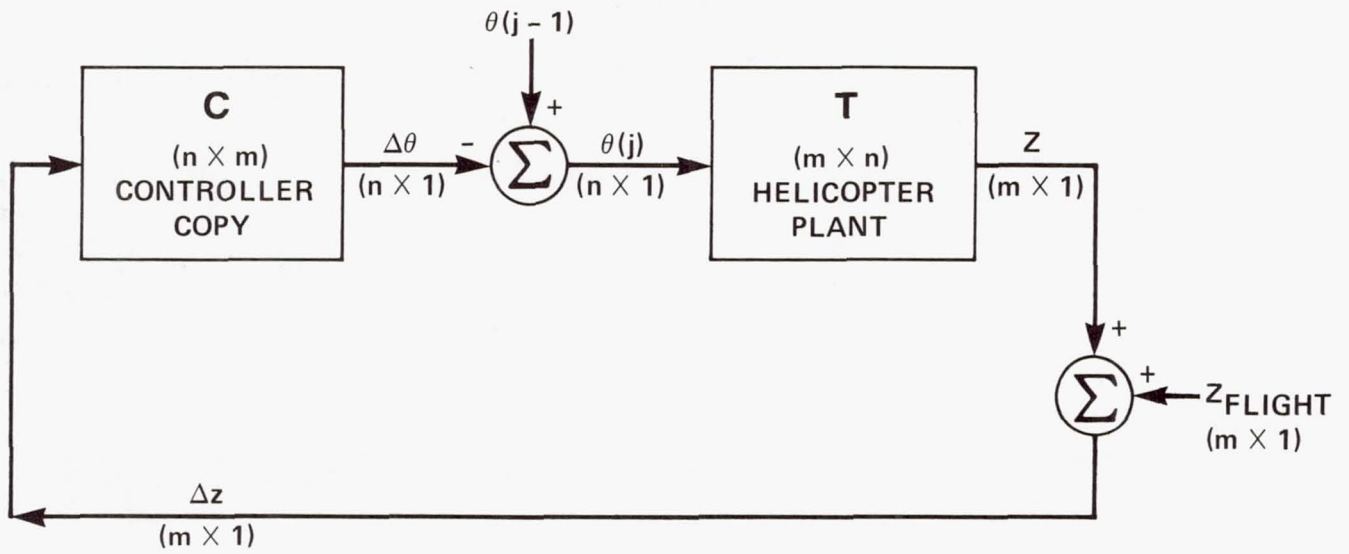

Figure 1.- An inverse controller where  $C$  is the inverse of  $T$ .

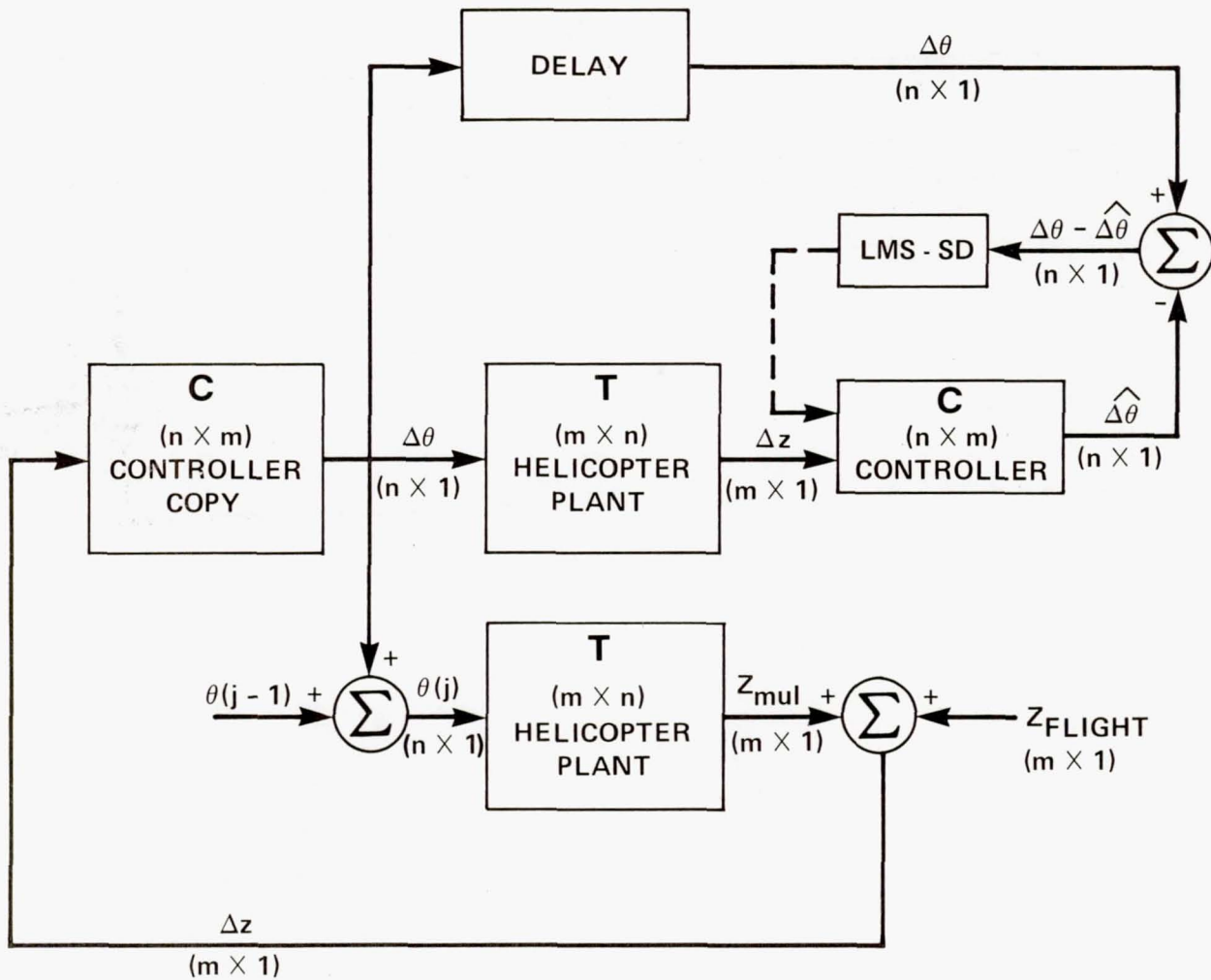

Figure 2.- An adaptive inverse controller where  $Z_{mul}$  is the multicyclic control component used to cancel the flight vibration,  $Z_{flight}$ .

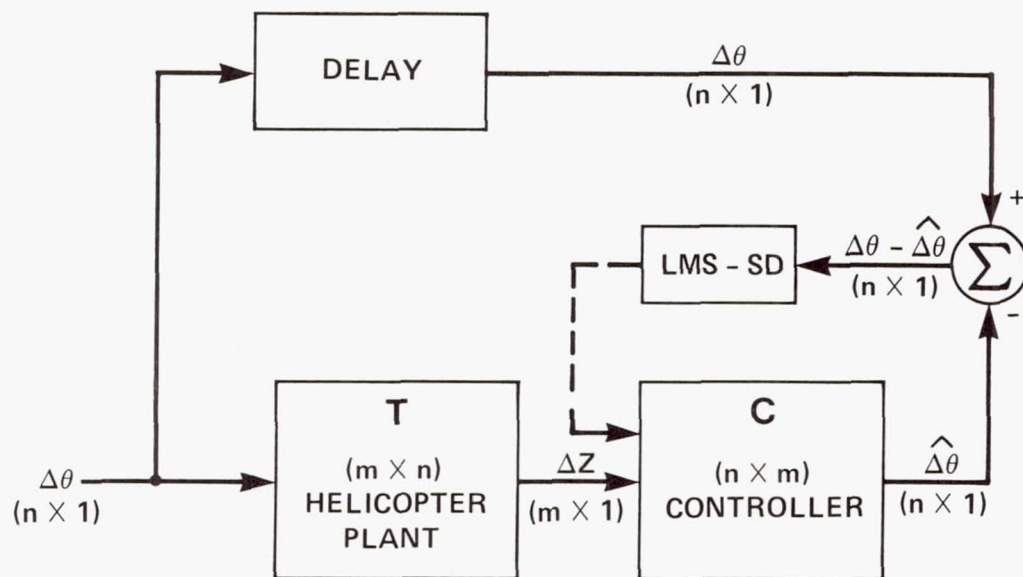

Figure 3.- Formation of the adaptation error used by the LMS-SD algorithm to correct the estimate of the inverse plant matrix, C.

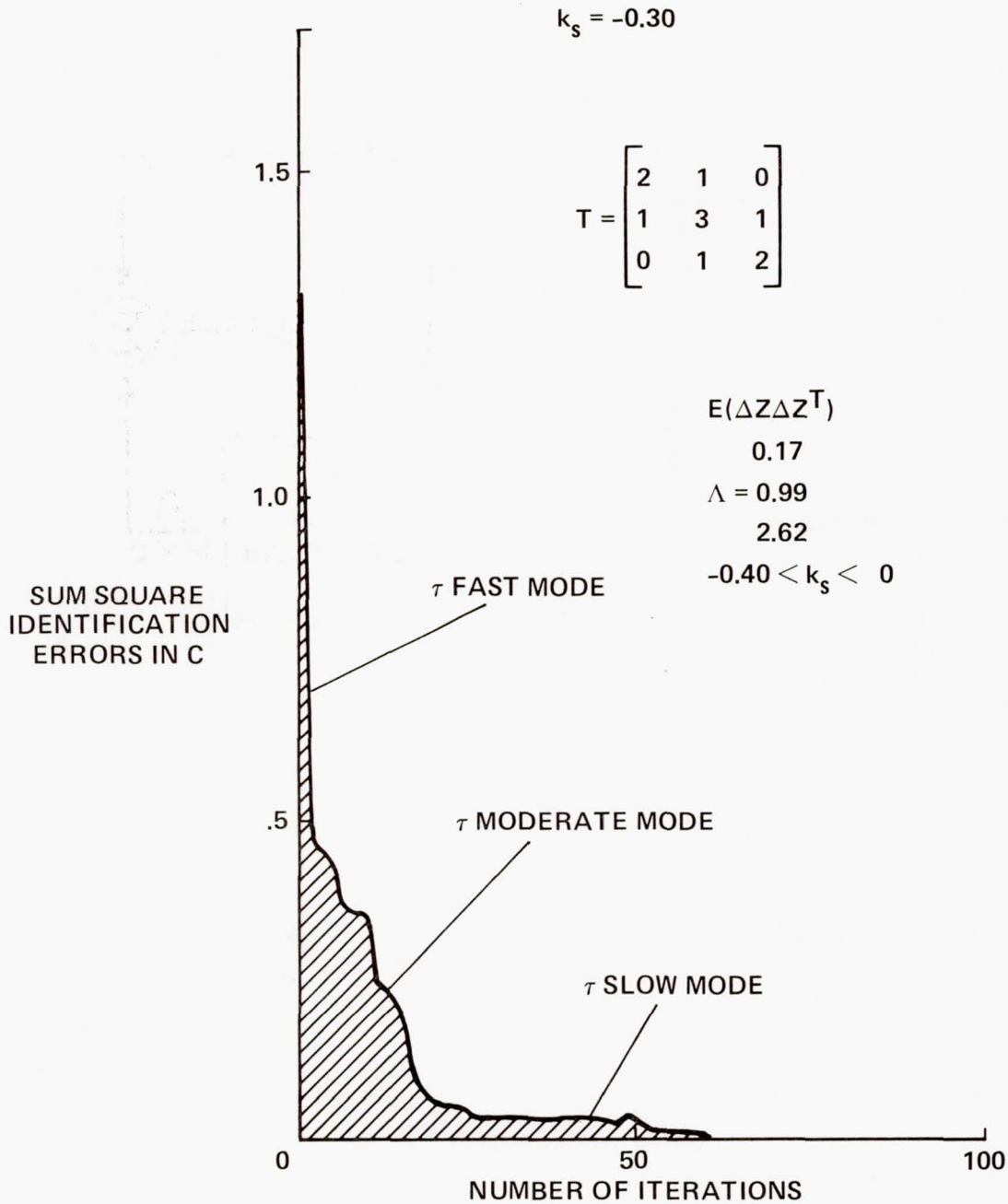

Figure 4.- The "learning curve" of the adaptation process, or a plot of the sum square error in the controller (inverse) identification versus the number of iterations from initial conditions;  $k_s$  chosen near the middle of its stability range.



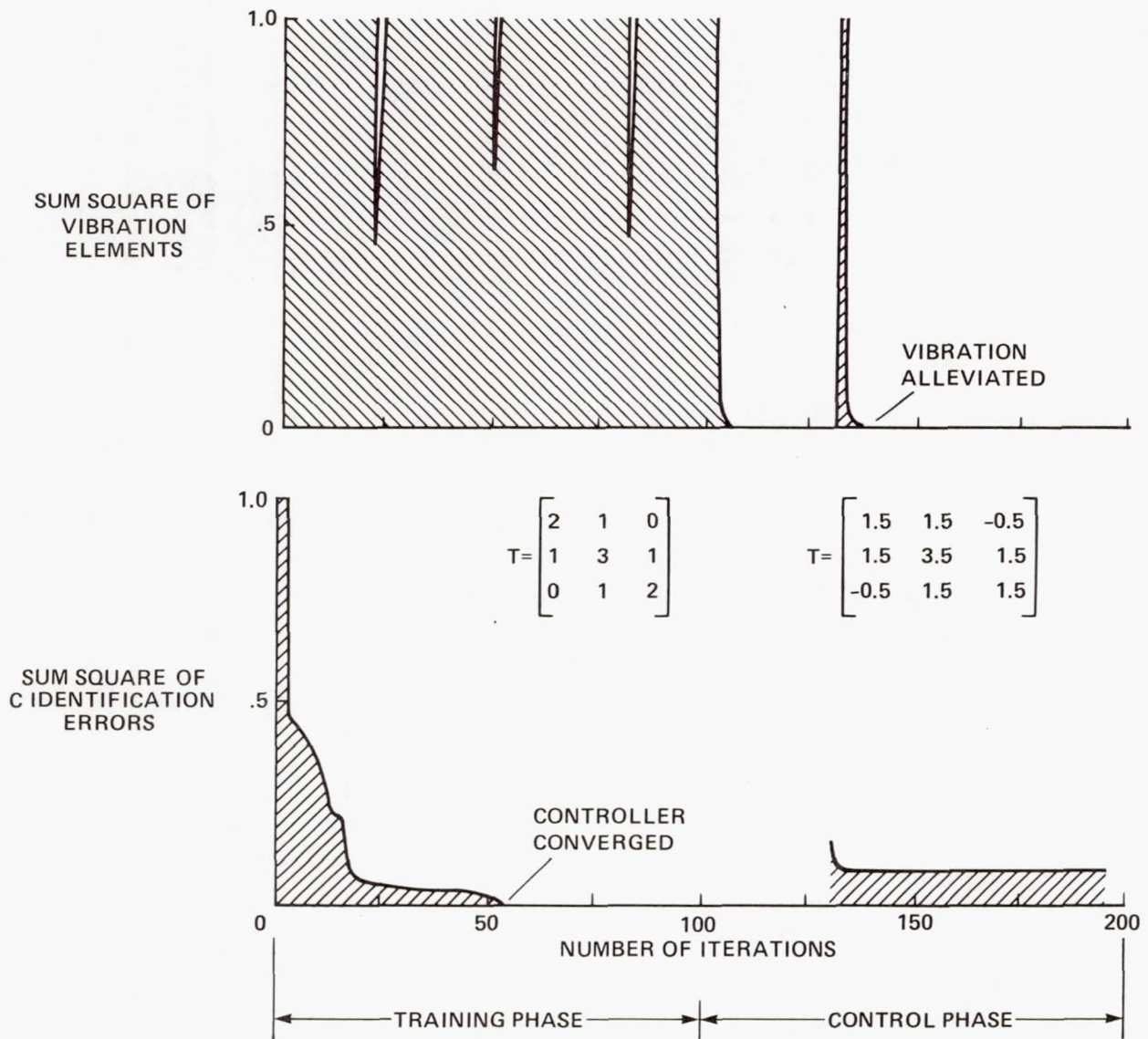

Figure 5.- Controller convergence properties during the training and control phases, along with the uncontrolled vibration. The effect of a 20% change in the plant transfer matrix, T, and a 40% change in the uncontrolled vibration.

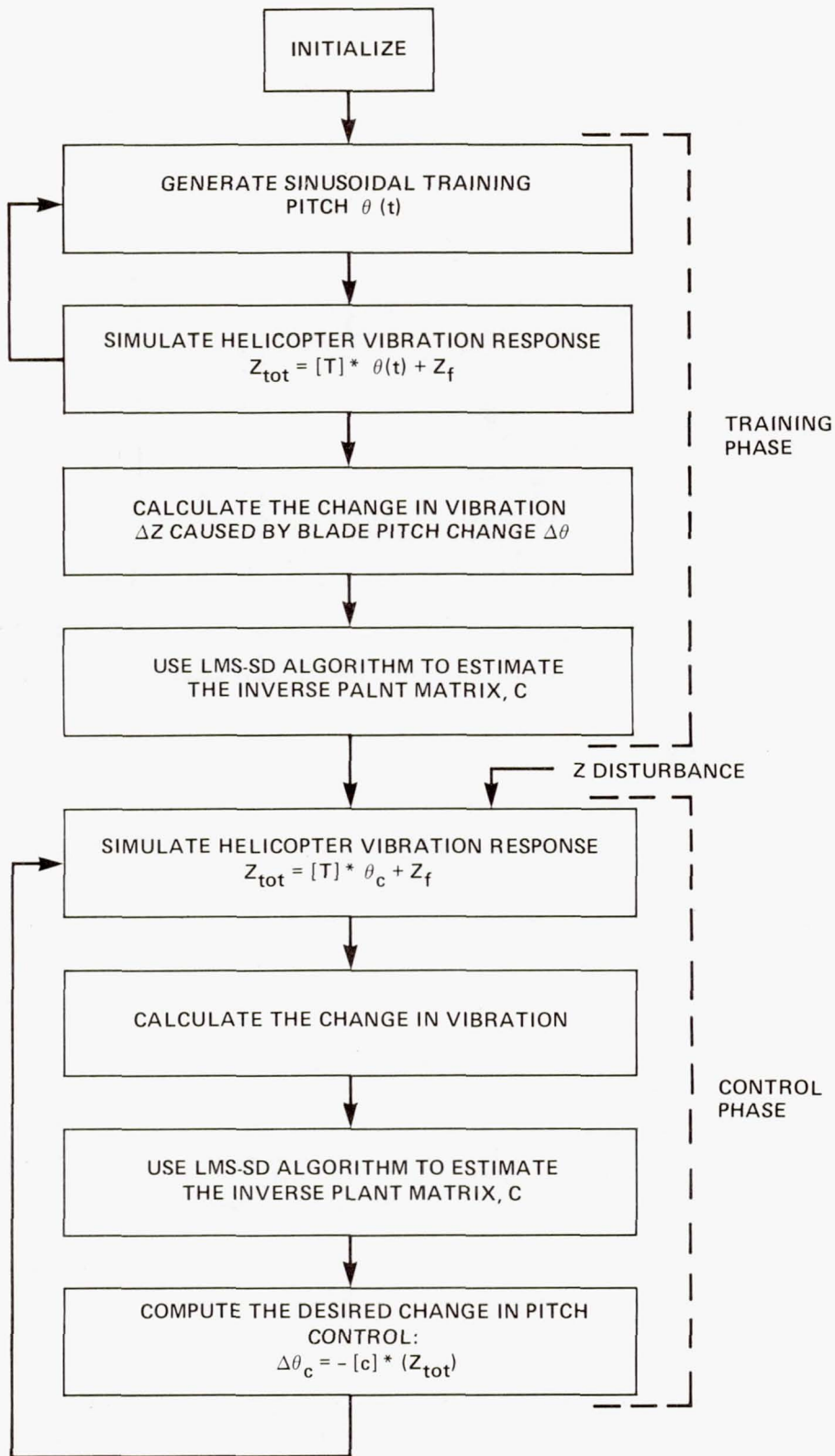

Figure 6.- LMS steepest descent program.

1. Report No. NASA TM-84336	2. Government Accession No.	3. Recipient's Catalog No.	
4. Title and Subtitle ADAPTIVE INVERSE CONTROL FOR HELICOPTER VIBRATION REDUCTION		5. Report Date September 1983	6. Performing Organization Code A-9472
		8. Performing Organization Report No.	
7. Author(s) Stephen A. Jacklin		10. Work Unit No. T-5484A	
9. Performing Organization Name and Address NASA Ames Research Center Moffett Field, Calif. 94035		11. Contract or Grant No.	
		13. Type of Report and Period Covered Technical Memorandum	
12. Sponsoring Agency Name and Address National Aeronautics and Space Administration Washington, D.C. 20546		14. Sponsoring Agency Code 505-42-11	
		15. Supplementary Notes Point of Contact: Stephen A. Jacklin, Ames Research Center, MS 247-1, Moffett Field, Calif. 94035. (415) 965-6668 or RTS 448-6668.	
16. Abstract  The reduction or alleviation of helicopter vibration will reduce maintenance requirements while at the same time increase ride quality and helicopter reliability. In forward flight, the helicopter's fuselage vibration spectrum tends to be dominated by multiples of the "N/REV" component. This paper presents a way to use the method of adaptive inverse control to identify, in real-time, a controller capable of generating N/REV vibration of opposite phase to cancel the uncontrolled N/REV component. The control considered in this paper will be that of multicyclic feathering of blade pitch.			
17. Key Words (Suggested by Author(s))  Helicopter vibration control Automatic control		18. Distribution Statement  Unlimited  Subject Category - 08	
19. Security Classif. (of this report) Unclassified	20. Security Classif. (of this page) Unclassified	21. No. of Pages 19	22. Price* A02