

NASA TM-85707

NASA Technical Memorandum 85707

NASA-TM-85707 19840003125

A GROUND TEST MEASUREMENT SYSTEM FOR THE
SHUTTLE ENTRY AIR DATA SYSTEM

FOR REFERENCE
DO NOT REMOVE FROM FILE
NOT TO BE REPRODUCED

Paul C. Schutte

OCTOBER 1983

LIBRARY COPY

OCT 17 1983

LANGLEY RESEARCH CENTER
LIBRARY, NASA
HAMPTON, VIRGINIA



National Aeronautics and
Space Administration

Langley Research Center
Hampton, Virginia 23665

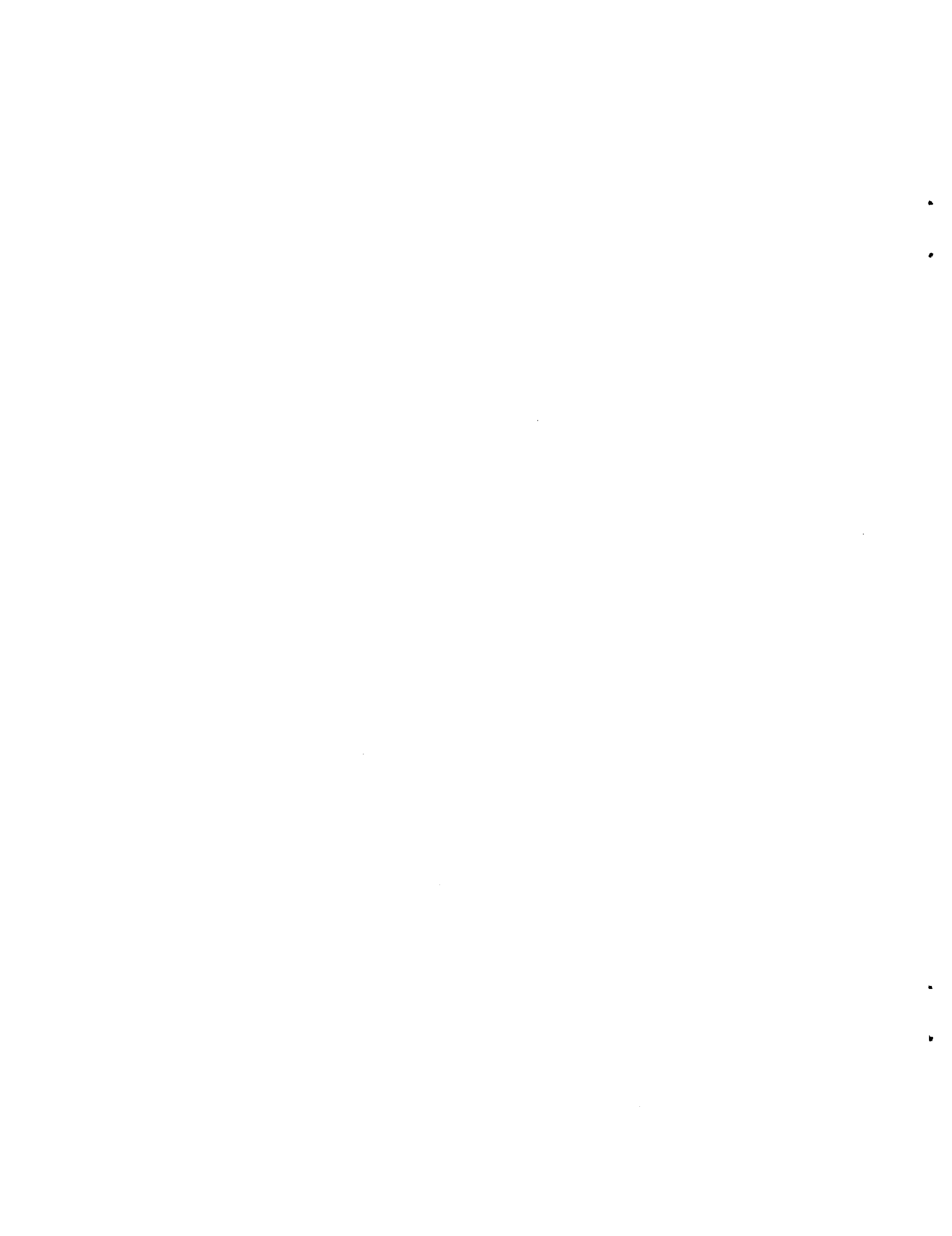

A GROUND TEST MEASUREMENT SYSTEM
FOR THE SHUTTLE ENTRY AIR DATA SYSTEM

Paul C. Schutte
NASA Langley Research Center

SUMMARY

A Ground Test Measurement System (GTMS) for the Shuttle Entry Air Data System (SEADS), intended for determining vacuum decay leak rates up to 34.5 kPa/sec within the orifice tubing assembly and measuring pressures up to 138 kPa to within $\pm 8 \times 10^{-3}\%$ of full scale, is described. The GTMS consists of a vacuum rate-of-decay meter, two high accuracy pressure gages of ranges 0 to 138 kPa and 0 to 34.5 kPa, a portable helium leak detector, a portable vacuum pump and accessories. The system determines leak rate by measuring vacuum pressure decay which can be converted into flow rate. Results of performance testing and operation of the GTMS are given.

INTRODUCTION

The Shuttle Entry Air Data System (SEADS) utilizes the space shuttle orbiter as a full scale experimental model to collect aero-thermodynamic data. The SEADS hardware is located in the orbiter nose (fig. 1). Fourteen pressure orifices are positioned in a cross pattern on the nose cap. Each orifice is connected to two pressure transducers of ranges 7.2 kPa (150 psfa) and 138 kPa (20 psia) (fig. 2). The transducers are mounted behind an insulated bulkhead to protect them from the extreme heat of re-entry. The tubing ahead of the bulkhead is thermally protected by an acilside coating. The orifice port itself and the fittings which connect the tubing to the orifice port (fig. 3) are also coated. Significant leaks were expected to occur due to a low torque limitation in the assembly of these fittings (ref. 1). During re-entry the acilside coating on the assembly parts becomes fluid at high temperatures and will flow over the leaks and seal them once the coating cools. As a result the leak rate in the tubing assembly may vary with each flight. Since the purpose of SEADS is to compare the stagnation pressure at each of the fourteen orifice locations, varying leak rates between flights and between ports could jeopardize the value of such a correlation.

A Ground Test Measurement System (GTMS) was needed to determine the leak rates in each orifice tubing assembly. Major criteria for this system were that it be portable, that it perform all measurements in situ, that it locate leaks during assembly, that it perform an in situ check calibration on the flight transducers, and that it meet all specifications imposed by NASA (ref. 2). The measurement capability of the system must be flexible since the magnitude of the leaks was unknown. The system must be portable since it would be used at Rockwell International in Downey, California, and at the Orbiter Processing Facility at the Kennedy Space Center. The measurements must be performed in situ because the nose cap and bulkhead door cannot be removed once they have been put into place. The mating between the GTMS and the nose cap must be made at the orifice port and must not alter the orifice in any way.

The Ground Test Measurement System

The SEADS GTMS was designed and assembled at Langley Research Center (LaRC). The primary parts of the GTMS are a vacuum rate-of-decay meter and two pressure gages (fig. 4). These instruments will be used to: (a) determine the vacuum decay rate in each orifice assembly, (b) monitor the absolute pressure within the test system, and (c) under certain conditions provide a check calibration of the flight transducers. To determine the vacuum decay rate in an orifice tubing assembly, a time interval (e.g., 0.5, 2, 10 sec, etc.) is set within a digital timer in the rate-of-decay meter by the system operator. The vacuum rate-of-decay meter readout is set to display a net change in pressure, in psi. A pressure differential (atmospheric pressure minus pressure inside the tubing system) is set on the limit setting of a digital comparator which controls the pressure level at which the test will be triggered. Pneumatic connections are made between the test equipment and the SEADS orifice. The pressure in the entire test system is decreased using a mechanical pump. When the pressure level is at its equilibrium or "Minimum Pressure" (i.e., pressure level will not decrease appreciably with time), a solenoid trigger valve which acts as a shut off valve for the pump is closed. The pressure then increases due to leaks in the orifice tubing assembly. When the pressure increases past the limit setting on the digital comparator, the comparator engages the timer automatically which tares the display to zero and locks the display at the end of the timer interval. The net change in pressure displayed can then be divided by the time interval to provide a vacuum decay rate in psi/sec. The vacuum decay rate can be converted into leakage flow by;

$$Q_v = (1.115)(V) \frac{\Delta P}{\Delta t}$$

where Q_v is leakage flow in cc/sec, V is the test volume in in^3 and $(\Delta P/\Delta t)$ is leak rate in psi/sec (ref. 3). The vacuum rate-of-decay meter is a microprocessor controlled modular system containing four separate modules which plug into the system mainframe. The system had to be modified so that the comparator would engage the timer. The vacuum rate-of-decay meter uses a 138 kPa (20 psid) strain gage transducer,

The two digital pressure gages used are variable capacitance ceramic sensors having full scale ranges 138 kPa (20 psia) and 34.5 kPa (5 psia). These gages provide for the check-calibration of the SEADS flight transducers and monitoring of the absolute pressure in the orifice assembly during leak testing. During the check calibration, the pressure level inside the orifice tubing assembly is controlled using a mechanical pump and a micrometer valve which vents the assembly to atmosphere. When a preselected pressure level is achieved within the tubing system, the GTMS pressure gage readout is recorded along with the output voltages of the flight transducers. The pressure level may then be changed to the next set point and a new measurement taken. The check calibration data obtained can be compared to the laboratory calibrations to determine if the transducer sensitivity has shifted.

A tubing system (fig. 5) was designed so that the vacuum rate-of-decay meter and the pressure gages can be used independently or jointly. A choke system (fig. 6) was designed and installed to eliminate EMI generated by the solenoid trigger valve.

A portable helium leak detector (fig. 7) is included in the GTMS in order to locate small leaks during the assembly of the SEADS flight hardware. It is also used to periodically maintain pneumatic integrity within the tubing of the GTMS. The leak detector uses a mass spectrometer and an air cooled diffusion pump to detect helium which enters the system through leaks. This particular unit was chosen because it does not require liquid nitrogen as most helium leak detectors do. Such a requirement would greatly decrease the portability and flexibility of the system. The leak detector cannot be used once the flight hardware has been assembled because it would be impossible to leak check the tubing once the bulkhead door has been closed and the nose cap has been placed on the orbiter.

Because all operation of the GTMS requires a vacuum pump, for use as a service pump, a small direct drive mechanical pump (fig. 8) was included in the GTMS. The only requirement on this pump was that it be equipped with an anti-backup valve which would serve as an internal shutoff to minimize reverse oil flow which could contaminate the SEADS flight hardware.

The GTMS equipment is housed in three rugged, lightweight cases for transportation. One of the cases contains an accessory compartment in the lid which contains all tools and spares necessary for the operation of the GTMS. Appendix A lists and describes the operation of all GTMS instrumentation, specifications and contents of the storage compartment.

A detailed operational procedure (Appendix B) was developed to insure uniformity and integrity of the data collected and to protect against misuse of the system. The procedure also details how the system may be used to adjust the zero and span of the helium leak detector and vacuum rate-of-decay meter and the zero on the pressure gages in the field.

The orifice vacuum seal connector is used to make the in situ, pneumatic connection from the GTMS to the SEADS orifice. The connector (fig. 9 and 10) seals to the port by vacuum seal on the O-ring. The vacuum seal connector is hand positioned on the SEADS orifice port (not on the RCC nose cap material) such that the outer diameter of the connector lines up with that of the port (fig. 11) and a vacuum is established. The vacuum will hold the connector to the port, but it is hand-held during the test as a safety precaution. When the test cycle has been completed the seal may be removed after the tubing system has been vented back to atmosphere.

Precision

All instrumentation in the GTMS was laboratory tested at LaRC to determine their performance characteristics.

The helium leak detector was determined to be capable of detecting leaks as small as 10^{-10} cc/sec at standard atmospheric conditions. The sensitivity and zero are adjustable from the front panel and need to be adjusted prior to use.

The vacuum rate-of-decay meter is capable of measuring absolute pressure to within $\pm 2.5 \times 10^{-1}\%$ of full scale. The system has been determined to measure vacuum decay rates to within $\pm 3\%$ of the reading. The relationship between error and vacuum decay rate is to be expected within a digital system such as this. The two digital pressure gages have a measurement error of $\pm 8 \times 10^{-2}\%$ of full scale.

The check-calibration test operates on the premise that the pressures in the GTMS and orifice assembly are equal. This may not always be true. The mechanical pump and the GTMS pressure gages are pneumatically located on one side of the potential leak (at the coated orifice fixtures), and the SEADS flight transducers are on the opposite side of the leak. As the mechanical pump evacuates the system, ambient air will enter the system through the leak. At small vacuum decay rates ($< 2 \text{ kPa/sec}$), this is not a problem. However at large vacuum decay rates, a pressure differential is established within the system, and the pressure at the GTMS gages cannot be assumed to be equal to that at the SEADS flight transducers. Tests were performed to determine criteria for performing check calibrations. Based on these tests, it was determined that a check calibration would not be performed unless the "Minimum Pressure" in the test port is equal to or less than 1.4 kPa (0.2 psia). If the "Minimum Pressure" is below 1.4 kPa, the 138 kPa transducers can be calibrated to within an accuracy of $\pm 3\%$ full scale. The 7.2 kPa transducers cannot accurately be calibrated unless the system is virtually leak free ($\leq 0.2 \text{ kPa}$).

Field Operation of the GTMS

The SEADS GTMS was used to conduct performance tests on the SEADS flight hardware at Rockwell International in Downey, California. The GTMS was approved by Rockwell International's quality assurance inspector. The vacuum decay rates ranged from 34.5 kPa/sec (5 psi/sec) to 13.8 kPa/sec (2 psi/sec). The check calibration of the flight transducers was not performed because the "Minimum Pressure" was too high.

Results

The SEADS GTMS has demonstrated that it fulfills its operational requirements. Laboratory and field experiments have given rise to the following results:

- o the GTMS has been proven capable of measuring vacuum decay rates ranging from 0 to 34.5 kPa/sec to within $\pm 3\%$ of the reading,
- o a check calibration of the 138 kPa SEADS flight transducers can be performed using the GTMS, within an uncertainty of less than $\pm 3\%$ of full scale, providing that the "Minimum Pressure" is equal to or less than 1.4 kPa. The 7.2 kPa SEADS flight transducers can be calibrated accurately only if the SEADS orifice assembly is virtually leak free ($\leq 0.2 \text{ kPa}$),
- o the orifice vacuum seal connector provided an adequate, in situ, pneumatic seal for leak testing the SEADS orifice assembly,
- o The GTMS was transported to Rockwell International where it performed successful measurements upon the SEADS flight hardware.

CONCLUDING REMARKS

The SEADS Ground Test Measurement System has been designed and assembled at LaRC. This system is able to measure vacuum decay leak rates and monitor pressure and is capable of performing an accurate, in situ vacuum decay measurement on the SEADS flight hardware. An in situ check-calibration of the SEADS transducers can be performed under certain conditions using the GTMS. Based on laboratory tests the GTMS has been certified operational and has been used to obtain vacuum decay measurements on SEADS flight equipment.

REFERENCES

1. While, D. M.: Shuttle Entry Air Data System (SEADS) Hardware Development Volume II, History. (Vought Corp.; NASA Contract NAS1-16000) NASA CR-166044, 1983.
2. Space Shuttle Program Ground Support Equipment General Design Requirements. NASA SW-E-0002, Revision B, 1976.
3. Digital, Pressure Decay Leak Testers, TM 7630A, S. Himmelstein and Company, 1979.

APPENDIX A

INSTRUMENT DESCRIPTION

All Instrumentation Conforms to SW-E-002

Case 1

Contains one direct drive rotary vane mechanical pump

- Precision Scientific Model DD195
- Pumping speed - 1.62 l/sec at 1.3 Pa
- Blank off pressure - 1.3 Pa
- Free air displacement - 3.25 l/sec
- Oil capacity - 1 l
- Sound level - 65 db at 8 cm
- Motor - 1/2 HP, 1725 RPM
- Power - 115 VAC @ 6 amps
- Weight of case 1 - 35 kg
- Exterior dimensions of case 1 - 66 x 61 x 24 cm

Case 2

Contains one portable, trapless helium mass spectrometer leak detector

- Varian Associates Model 936-40
- Sensitivity - 10^{-5} Pa-cc/sec
- Power - 115 VAC @ 6 amps
- Weight of case 2 - 25 kg
- Exterior dimensions of case 2 - 61 x 53 x 33 cm

Case 3

Contains leak rate pressure instrumentation

- S. Himmelstein and Co., Model System 6
- Transducer range - 138 kPa
- Contains four removable modules
 1. Digital Tare/Scanner Model 6-423
 2. Transducer Amplifier Model 6-201
 3. Digital Timer Model 6-305
 4. Dual Digital Limit Model 6-702
- Power - 115 VAC @ 1 amp

The vacuum rate-of-decay meter is a microprocessor controlled modular system. It contains four separate modules which plug into the system mainframe. The system has a six digit LED display. The first module is a digital tare scanner used to control the flow of digital and analog data within system. A useful feature which this module contains is the ability to tare a transducer signal at any given time and display a net change in that signal on the display in pressure units (psi). The second module is the digital timer which generates a precise time delay whose duration is determined by internal switch settings. The time delay can

be varied from 10^{-3} to 9.9×10^4 seconds. The timed interval may be started by a front panel push button switch or by a remote logic signal. Front panel LED's indicate the status of the timer which can be reset either manually from the front panel or remotely. There are three LED indicators, amber for timer reset, green for timer on, and red for interval over. This module is easily removed to preselect the time interval duration on six sets of four pole DIP switches. The third module in the system is a dual digital comparator. It has two sets of thumbwheel set switches (sign and five decades) on the front panel; one for a high limit setting and one for a low limit setting. LED indicators display the position of a pressure signal with respect to the high and low limit settings; green when the pressure data is greater than the lower limit and less than the upper limit, amber when the pressure data is greater than or equal to the high limit. The module and mainframe are wired so that when the pressure data crosses the high limit setting, a remote "reset" and "start" signal is sent to the timer. The fourth module of the system is the high accuracy transducer amplifier. The zero and span can be manually adjusted from the front panel. It has a four-level Bessel response output filter with 0.1, 1, 100, and 500 Hz bandwidths. The pressure transducer used in this system is 138 kPa (20 psid) bonded foil strain gage device which is manufactured by Viatran Corporation. The response time of this transducer is less than 10^{-3} sec and has a natural frequency of 5 kHz. Due to the operational characteristics of this transducer, the tubing connection is made through the reference port.

Contains two pressure gages

- Setra Systems Model 361 variable capacitance ceramic sensor
- Range - 0 to 138 kPa and 0 to 34.5 kPa
- Accuracy - to within 0.05% of FS
- Display update -2.5 readings per second
- Maximum overpressure - 100 kPa for the 34.5 kPa gage
200 kPa for the 138 kPa gage
- Power - 115 VAC @ 0.1 amps

All vacuum fittings are stainless steel Swagelok type. The valves are Nupro SS-4H except for valve 4 which is a Whitey SS-RS-2, micrometer valve.

The electrical outlets on Case 3 are two pole, three wire Hubbell Twist-Lock type rated at 250 VAC @ 10 amps and 125 VAC @ 15 amps.

The "Power" toggle switch is a single pole, aircraft type, FSN 5930-00-655-1514 which conforms to military specifications MS 35058-22.

The "Trigger" rotary switch consists of detent, FSN 5930-00-404-6707 and wafer, FSN 5930-00-222-8142.

The trigger valve is normally open, piloted piston operated, 2-way solenoid type manufactured by ITT General Controls. The solenoid coil is rated at 125 VAC @ 10 watts.

Accessories compartment contains

- 2 vacuum seals
- 1 9/16 open and closed end wrench
- 1 standard screw driver
- 1 phillips screw driver
- 1 small adjustment screw driver
- 2 power cords
- 2 spare Hubbel twist-lock male plugs
- 2 spare Hubbel twist-lock female plugs
- 2 hose clamps
- 8 Swagelock $\frac{1}{4}$ " fittings
- 20 nylon Swagelock ferrals
- 10 spare neoprene o-rings
- 3 copies of the operations procedure

- Weight of case 3 - 36 kg
- Exterior dimensions of case 3 - 81 x 55 x 39 cm

The Ground Test Measurement System is connected to the SEADS orifice by a stainless steel vacuum steel and polyethylene tubing.

Polyethylene tubing

- Imperial Polyflo Tubing
- Outer diameter - 0.5 cm
- Tubewell thickness - 0.1 cm
- Burst pressure - 2800 kPa
- Minimum bend radius - 3 cm
- Weight 1.6 kg/100m
- Conforms to ASTM D-1248, type 1, class A, category 4 Federal specifications LP-390C, type 1, class L, grade 2, category 4.

Vacuum Seal Orifice Connector

- Stainless steel
- Neoprene o-ring conforms to Military specifications MIL-P-25732

APPENDIX B

Seads Ground Test Measurement System

Procedure Outline

I. Shipping Procedure

- A. Case 3 (Himmelstein Vacuum Decay Detector & Pressure Standards)
- B. Case 1 (Vacuum Pump)

II. Unpacking and Start-up Procedure

- A. Case 1 (Vacuum Pump)
- B. Case 3 (Himmelstein Vacuum Decay Detector & Pressure Standards)

III. Calibration Procedure

- A. Vacuum Decay Detector (Case 3)
- B. Pressure Standards (Case 3)

IV. Test and Operation Procedure

- A. Vacuum Decay Detector (Case 3)
- B. Pressure Standards (Case 3)

V. Shut-down Procedure

- A. Case 3 (Himmelstein Vacuum Decay & Pressure Standards)
- B. Case 1 (Vacuum Pump)

Section I Shipping Procedure

This procedure assumes that Cases 1 and 3 have been "Shut down" according to Section V.

I-A Case 3 (Himmelstein Vacuum Decay Detector & Pressure Standards)

1. Open valves 2 and 3 (counter-clockwise).
2. Close valves 1 and 4 (clockwise).

Note: Do not over tighten valve 4 - do not turn past zero.

3. Connect vacuum port to vacuum pump. Tighten swagelok nuts on "vacuum" port with wrench until snug-do not over tighten.
4. Switch on pump for 25 minutes.
5. Close valves 2 and 3 (clockwise). These steps will insure that the tubing remains outgassed or "clean".
6. Switch off pump and disconnect hose from Case 3.
7. Place port caps on "test" port and "vacuum" port - hand tight.
8. Secure and latch compartment.
9. Close case cover - lock and tighten all latches.

I-B Case 1 (Vacuum Pump)

1. Remove any hoses from vacuum port and replace in Case 1.
2. Remove vacuum port by unscrewing black ring (counter-clockwise). Remove port to expose o-ring. (Note: Make sure o-ring is seated on pump and not stuck to the port).
3. Place metal disk over o-ring.
4. Replace port and tighten black ring.
5. Connect electrical connections to power source and switch on pump for 30 sec. This will insure that the disk is sealed on the o-ring.
6. Switch pump off, disconnect power cord. Wind cord and twist tie.
7. Place Case 1 cover on base and lock and tighten latches.

Section II Unpacking and Start-up Procedures

This procedure assumes that Cases 1 and 3 have been prepared for "Shipping" according to Section I.

This procedure should also be used as a Start-up procedure if the cases have only been "Shut-down" according to Section V and have not been prepared for "Shipping", in this case follow only the starred (*) commands.

II-A Case 1 (Vacuum Pump)

1. Unlock latches and remove cover.
2. Unscrew black ring around vacuum port and remove port.
3. Remove metal disk from o-ring. (Note: The screwdriver may be necessary to pry disk off).
4. Replace disk into Case 3 compartment.
5. Replace port and tighten black ring hand tight.
- *6. Plug in electrical cord.
7. Switch on pump for just a few seconds to insure that it is working.
8. Switch off pump.

II-B Case 3 (Himmelstein Vacuum Decay Detector & Pressure Standards)

1. Unlock latches and open cover.
2. Remove caps from "test" and "vacuum" ports and replace in lid compartment.
- *3. Plug power cord found in Case 3 compartment into "main power" panel on Case 3 and then to power supply.
4. Turn "power" switch on.
5. The two Setra gages should read "-18.888" for approximately 50 seconds.
- *6. Press and lock power switch on Himmelstein Vacuum Decay Detector.
- *7. Press "test" on Himmelstein Vacuum Decay Detector, display should read "+88.888.
- *8. Connect power cord to "trigger power" on Case 3 and then to power supply.
- *9. Switch "trigger" to "on" and listen for solenoid to click.
- *10. Switch "trigger" to "off".

Section III Calibration Procedure

This procedure assumes that Cases 1 and 3 have been "Started-up" according to Section II.

The instruments in these cases should be calibrated at the beginning of each day of use according to this procedure.

III-A Himmelstein Vacuum Decay Detector (Case 3)

1. Open valves 1, 2, 3 and 4 (counter-clockwise).
2. Press and lock "gross" button on scanner (6-423A).
3. Use small screwdriver to adjust "r course null" and "r fine null" on amplifier A (6-201) so that the pressure readout is 00.000 psi.
4. When readout is 00.000 psi, press and hold "cal +" button on amplifier A (6-201) and wait 20 sec. use small screwdriver to adjust "span coars" and "span fine" so that the pressure readout is _____ psi +/-0.002 psi.
5. Release "Cal +" button and wait 10 sec. If pressure readout is not 00.000 then go to Step 3.
6. When both "cal +" and "gross" read as prescribe in Steps 3 and 4, then calibrated is complete.

III-B Pressure Standards (Case 3)

1. Place small red hose with brass tubing connections on vacuum port on vacuum pump (Case 1).
2. Remove tubing from Case 1 cover and connect to brass tubing connection.
3. Connect Vacuum Pump hose "vacuum" port on Case 3 using nuts & ferrals.
4. Open valves 2 and 3 (counter-clockwise).
5. Close valves 1 and 4 (clockwise) - do not over tighten!
6. Switch on pump.
7. Pump for 15 minutes.
8. Close valve 3.
9. Adjust Setra readouts to 0.003 psi using a small screwdriver on "zero adjust" screws on front of Setra face plates.
10. Switch off pump.

Section IV Test and Operation Procedures

This procedure assumes that Cases 1 and 3 have been calibrated according to Section III.

IV-A Vacuum Decay Detector (Case 3)

1. Press and lock "gross" button on scanner (6-423A).
2. Press and lock "1" button on amplifier A(6-201A).
3. Press "reset" button on timer (6-305) until "reset" led stays lit.
4. Connect vacuum pump to "vacuum" port on Case 3.
5. Open valves 1, 2, & 3 (counter-clockwise).
6. Close valve 4 (clockwise).
7. Connect tubing to "vacuum seal".
8. Connect "vacuum seal" tubing to "test" port.
9. Set pressure level on "high set point" on dual digital limit. (Because the pressure transducer is a differential type, in order for the timer to be engaged at x psia the "high set point" must be set at atmospheric pressure in psia minus x psia).
10. Hold "vacuum seal" tubing to "test" port.
11. Switch on vacuum pump - vacuum should hold seal to port, however the seal should continue to be manually held in place throughout the test.
12. Allow 30 sec for Himmelstein transducer to settle out.
13. Himmelstein readout should be approximately ambient pressure. Pressure readout should be blinking. If not check high set point setting.
14. Press and lock "net" button on scanner (6-423A).
15. Press and unlock "latching" on dual digital limit.
16. Switch "trigger" to "on".
17. When red led "interval over" on digital timer lights - record readout.
18. When readout has been recorded press "reset" on timer (6-305).*
19. Press and lock "latching" on dual digital limit.
20. To re-test this orifice - continue to hold vacuum seal in place and switch "trigger" to "off".

*If a new time interval is desired continue on to Steps 28 thru 34.

21. If testing is completed, switch vacuum pump and "trigger" to "off" and go to Section IV-C if not continue with Step 23.
22. Set pressure level on "high set point" on dual digital limit.
23. Open valve 4.
24. Move "vacuum seal" to next orifice to be tested. The outer diameter of the seal should line up with that of the orifice plug.
25. Close valve 4 (clockwise).
26. Switch "trigger" to "off".
27. Go to Step 13.
28. Press and unlatch "power" switch on Himmelstein Vacuum Decay Detector.
29. Use the phillips head screwdriver found in Case 3 compartment and back out the center screw of the "digital timer" (6-305). The timer module will slowly come out of the case.
30. When the screw ceases to back the module out of the case gently pull the module out to expose the four sets of dip switches.
31. Using the following two charts, set the dip switches to the desired interval.
32. Gently push the module back into the case and tighten screw.
33. Press and latch "power" switch on vacuum decay dectector.
34. Go to Step 20.

Chart 1

<u>Number</u>	<u>Switch Position</u>			
	<u>A</u>	<u>B</u>	<u>C</u>	<u>D</u>
0	ON	ON	ON	ON
1	OFF	ON	ON	ON
2	ON	OFF	ON	ON
3	OFF	OFF	ON	ON
4	ON	ON	OFF	ON
5	OFF	ON	OFF	ON
6	ON	OFF	OFF	ON
7	OFF	OFF	OFF	ON
8	ON	ON	ON	OFF
9	OFF	ON	ON	OFF

IV-B Pressure Standards (Case 3)

1. Turn "power" switch on Himmelstein Vacuum Decay Detector off.
2. Connect vacuum hose to "vacuum" port on Case 3.
3. Open valves 1, 2, and 3 (counter-clockwise).
4. Close valve 4. Do not over tighten.
5. Hold "vacuum seal" to orifice to be tested. The outer diameter of the seal should line up with that of the orifice plug.
6. Switch on vacuum pump - vacuum should hold seal to port, however the seal should continue to be held manually in place throughout the test.
7. Wait 5 minutes for pressure to stabilize.
8. When pressure has stabilized record readout from the Setra "0-5 psia" and from the orifice transducers.
9. Adjust valves 2 and 4 until the pressure readout on the Setra "0-5 psia".
10. Allow 30 seconds for the transducers to settle out.
11. Record readout from the Setra "0-5 psia" gage and the orifice transducers.
12. Adjust valves 2 and 4 until their pressure readout on the Setra "0-5 psia" gage reads approximately 1.000 psia.
13. Allow 30 seconds for the transducers to settle out.
14. Record readout from the Setra "0-5 psia" gage and the orifice transducers.
15. Adjust valves 2 and 4 until the pressure readout on the Setra "0-20 psia" gage reads approximately 7.500 psi.
16. Allow 30 seconds for the transducers to settle out.
17. Record readout from the Setra "0-20" gage and the orifice transducers.
18. Close valve 2 and open valve 4.
19. Allow 30 seconds for transducers to settle out.
20. Record readout from Setra "0-20 psia" gage and the orifice transducers.

Section V Shut-down Procedures

V-A Case 3 (Himmelstein Vacuum Decay Detector & Pressure Standards)

1. Press and unlatch "power" switch on Vacuum Decay Detector.
2. Switch off "power" switch on Case 3 panel.
3. Switch "trigger" to "off".
4. Disconnect power cords from power source.
5. Disconnect power cords from Case 3 panel.
6. Place power cords in Case 3 compartment.

V-B Case 1 (Vacuum Pump)

1. Switch off Vacuum Pump.
2. Disconnect power cord from power source.

NOSE SECTION

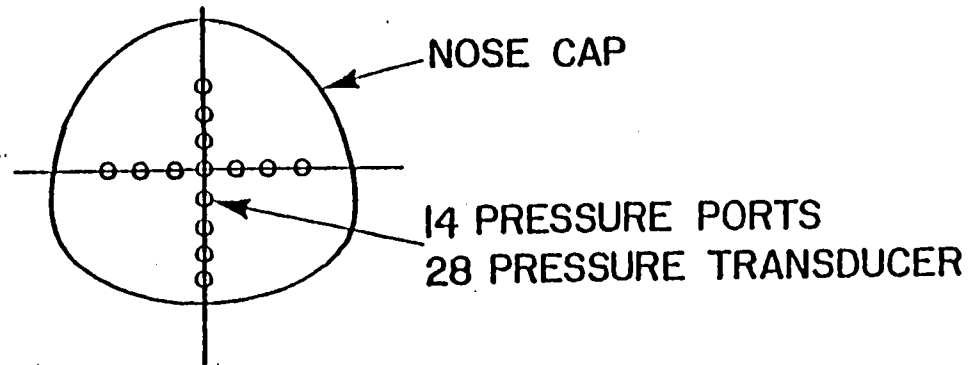
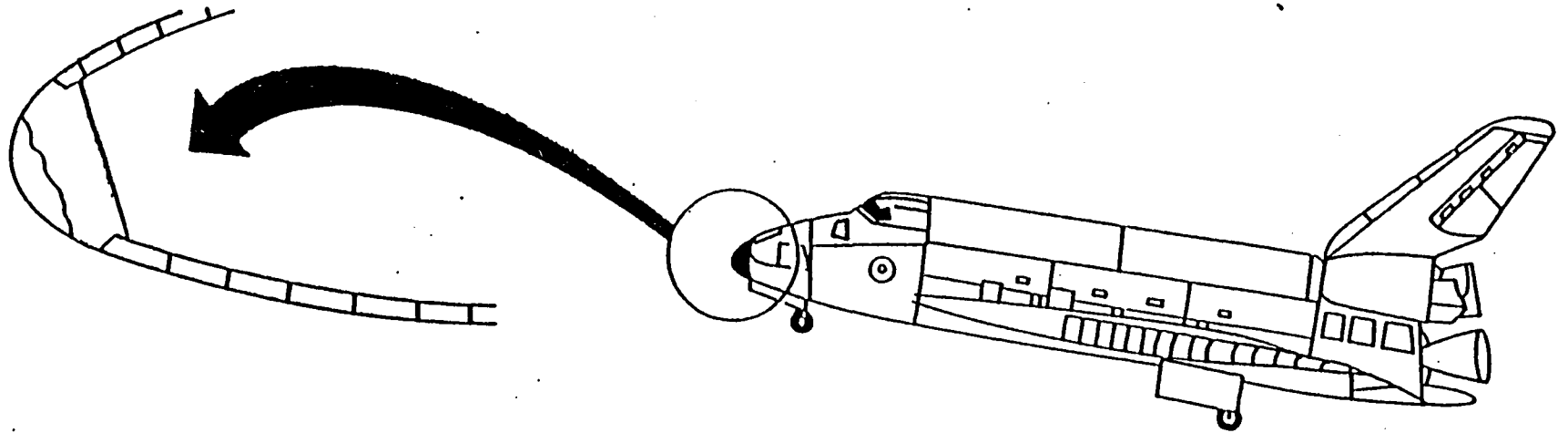

Figure 1-SEADS General Overview

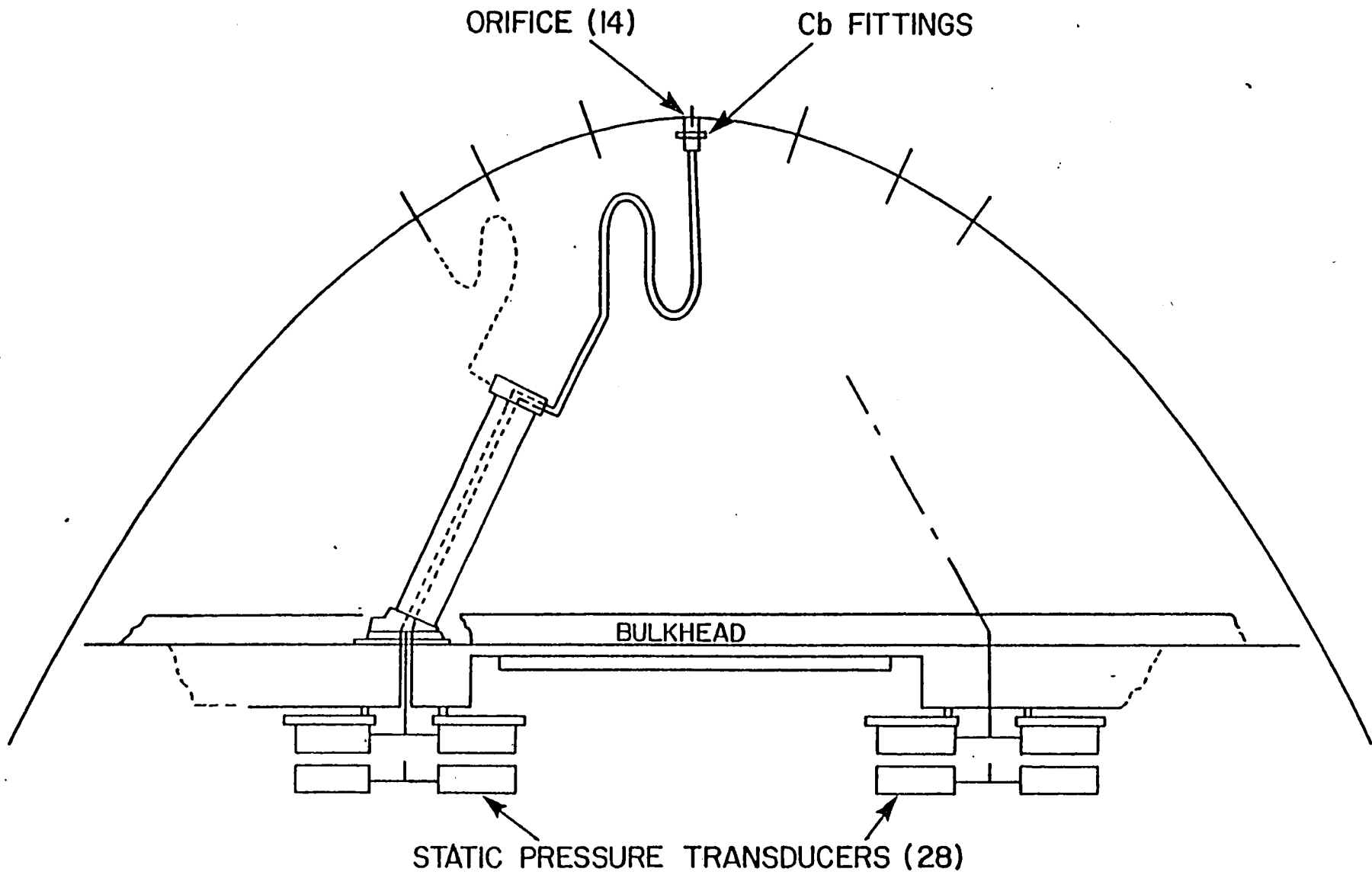
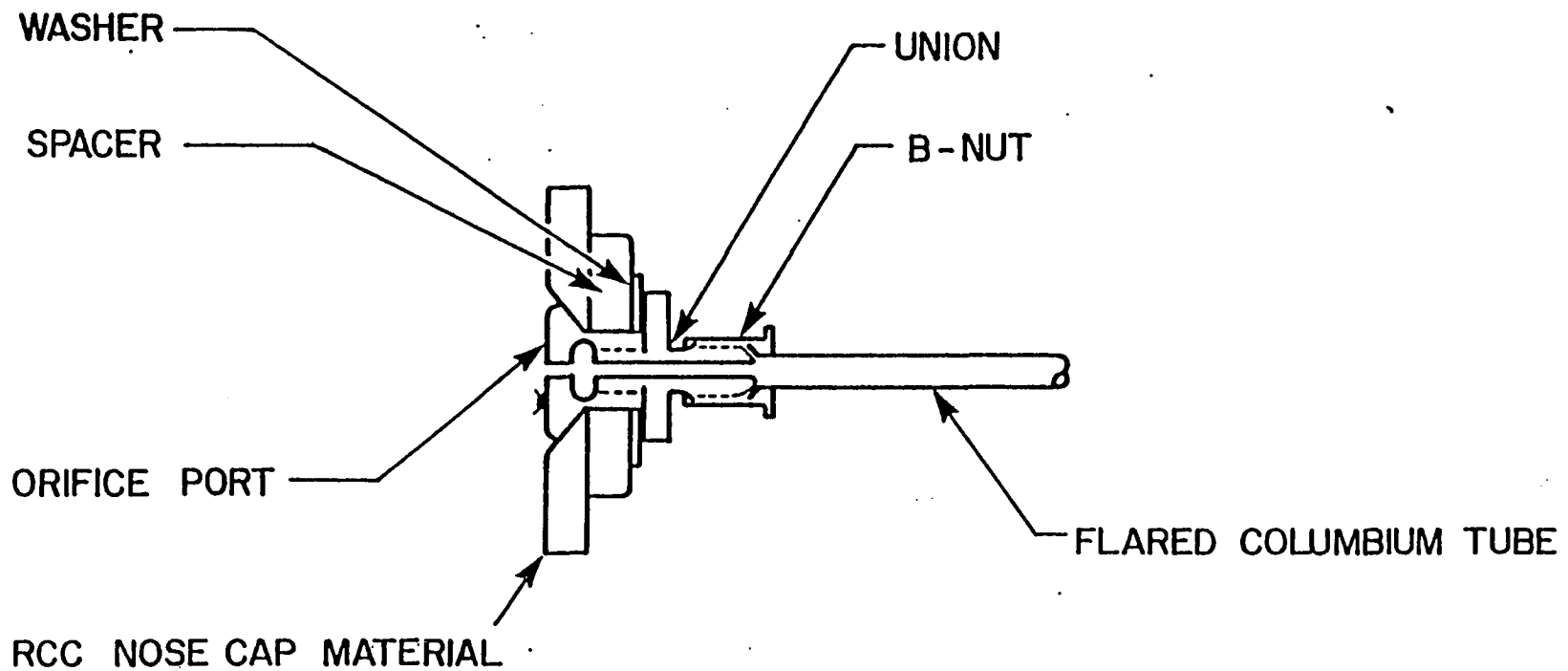

Figure 2-SEADS Tubing and Transducer Installation



ALL PARTS COATED WITH ACILISIDE COATING EXCEPT NOSE CAP MATERIAL

Figure 3-SEADS Orifice Configuration

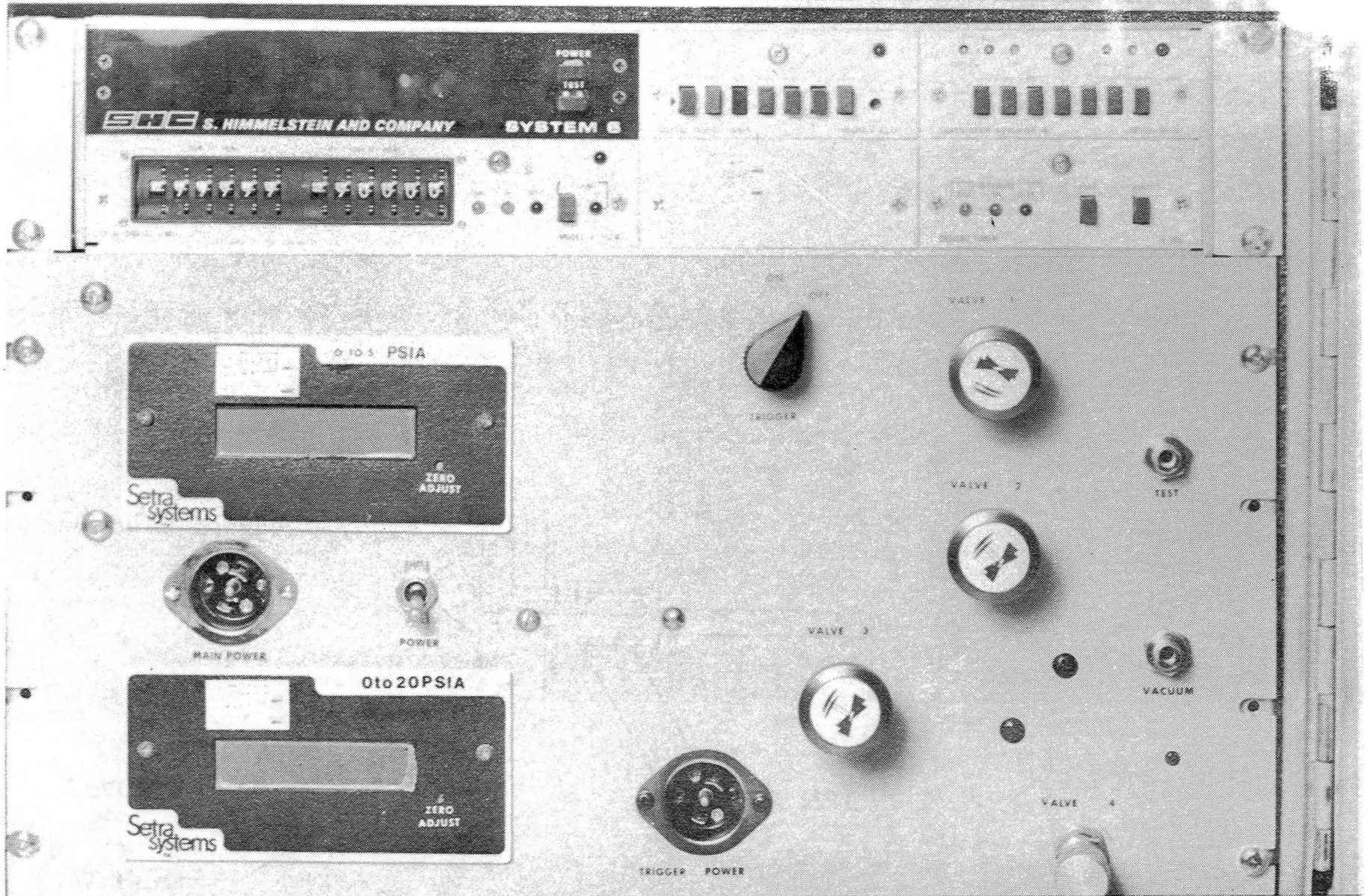

Figure 4-SEADS GTMS Vacuum Rate-of Decay Meter and Pressure Standard

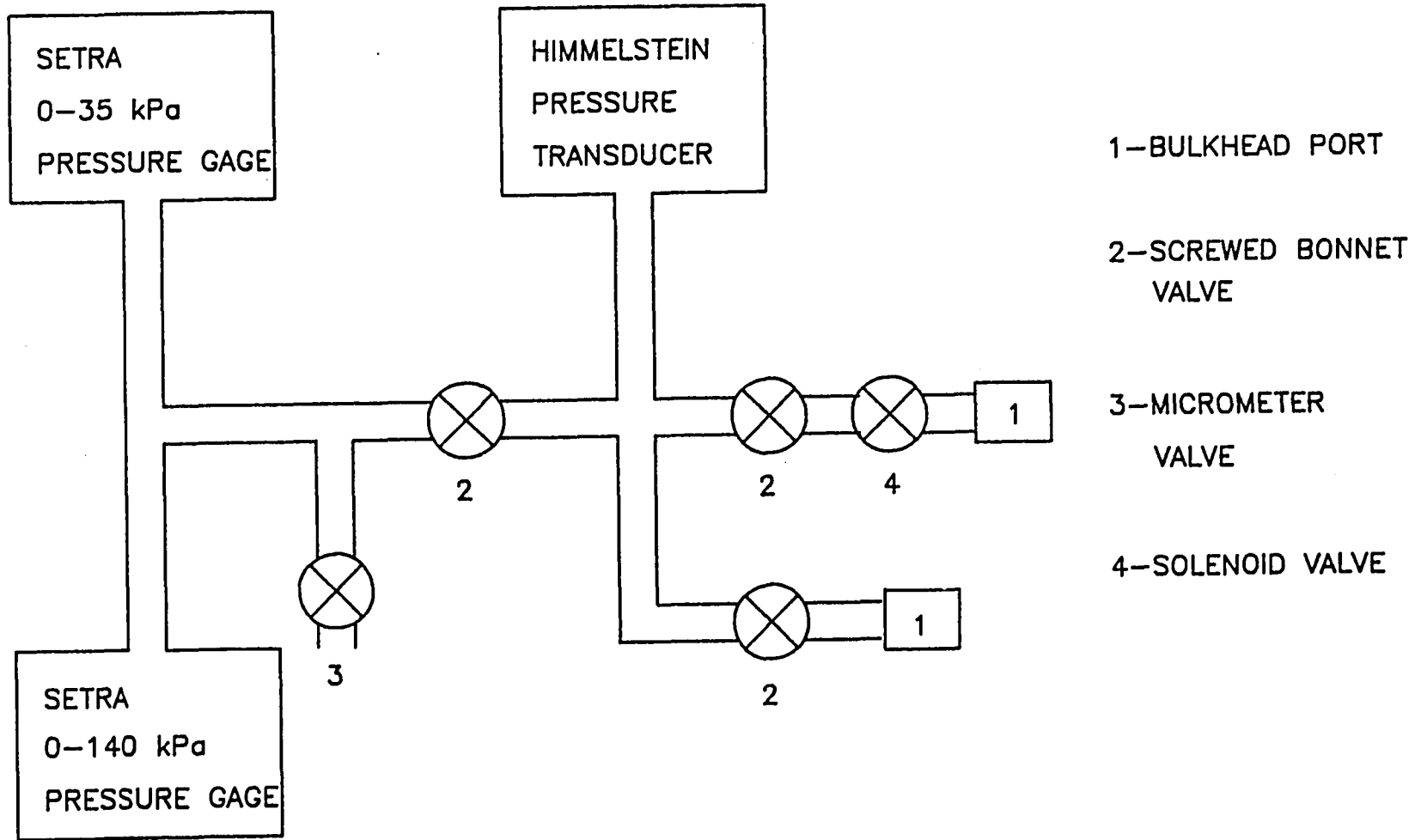
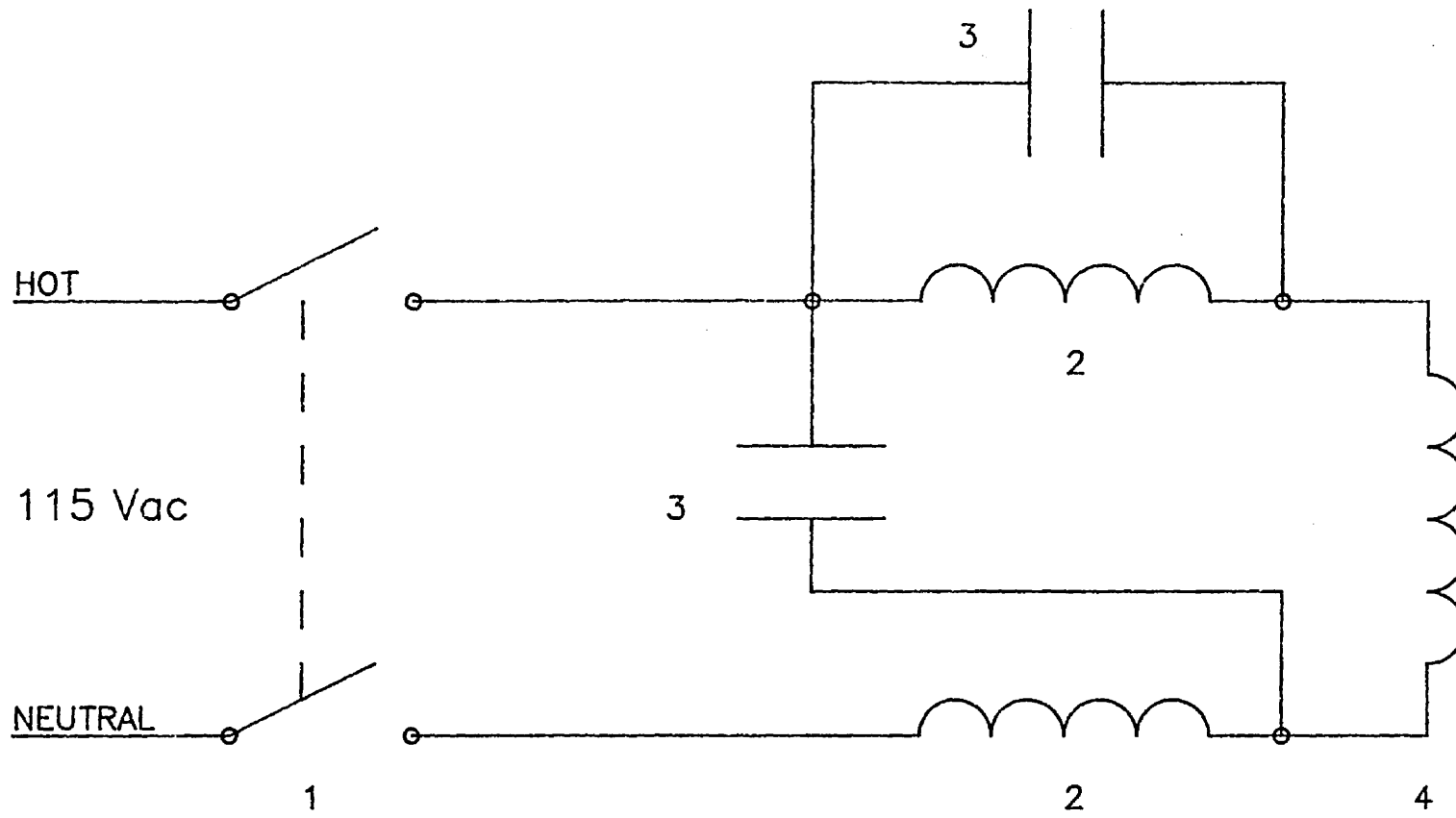

Figure 5-SEADS GTMS Tubing Diagram



1 Solenoid Trigger Switch

3 Capacitor – 6.8 nanofarads

2 Inductance Coil – 7 microhenries @ 1 Amp

4 Solenoid Valve

Figure 6—Choke System used for Solenoid Trigger

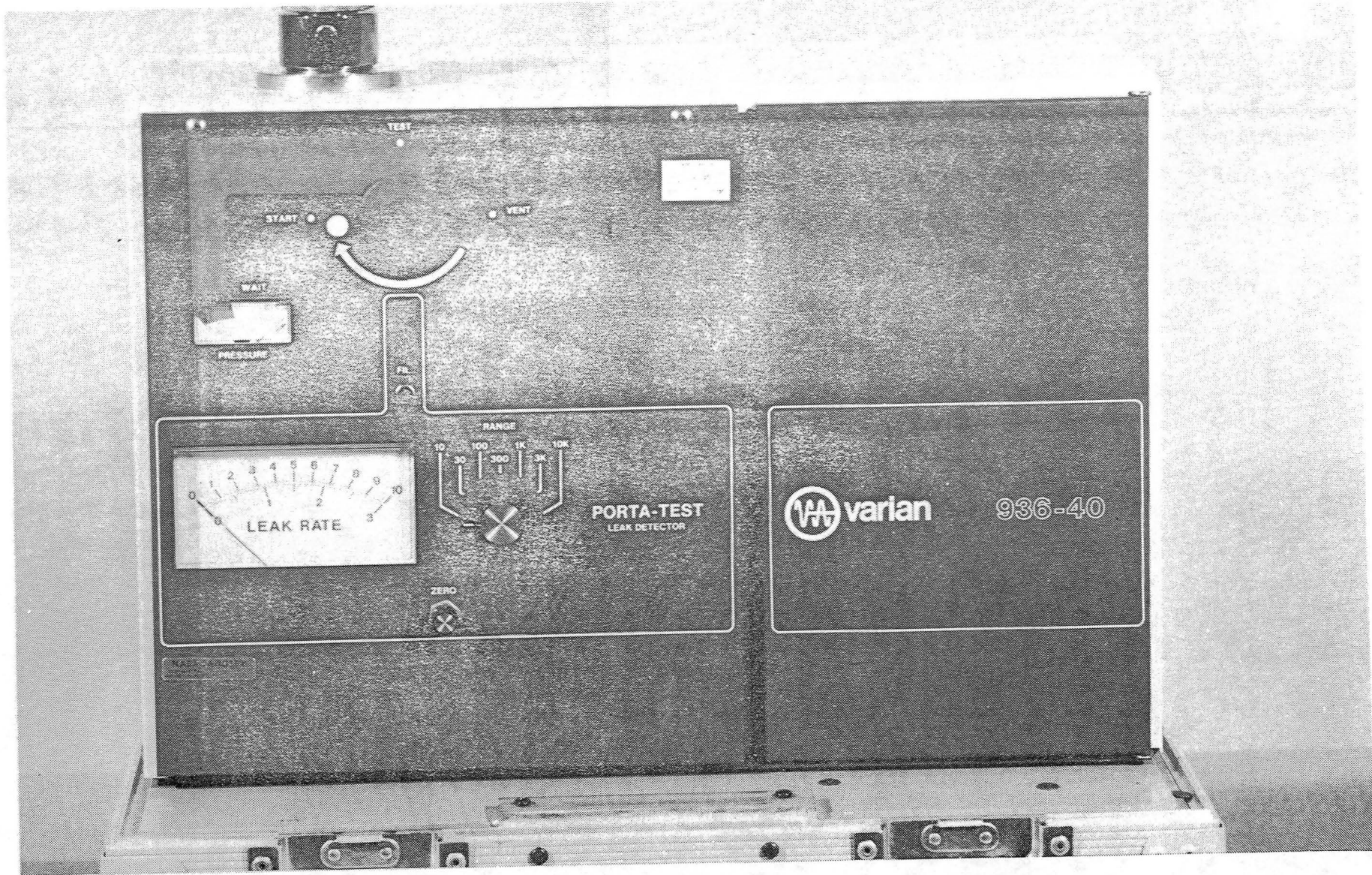

Figure 7—SEADS GTMS Portable Helium Leak Detector

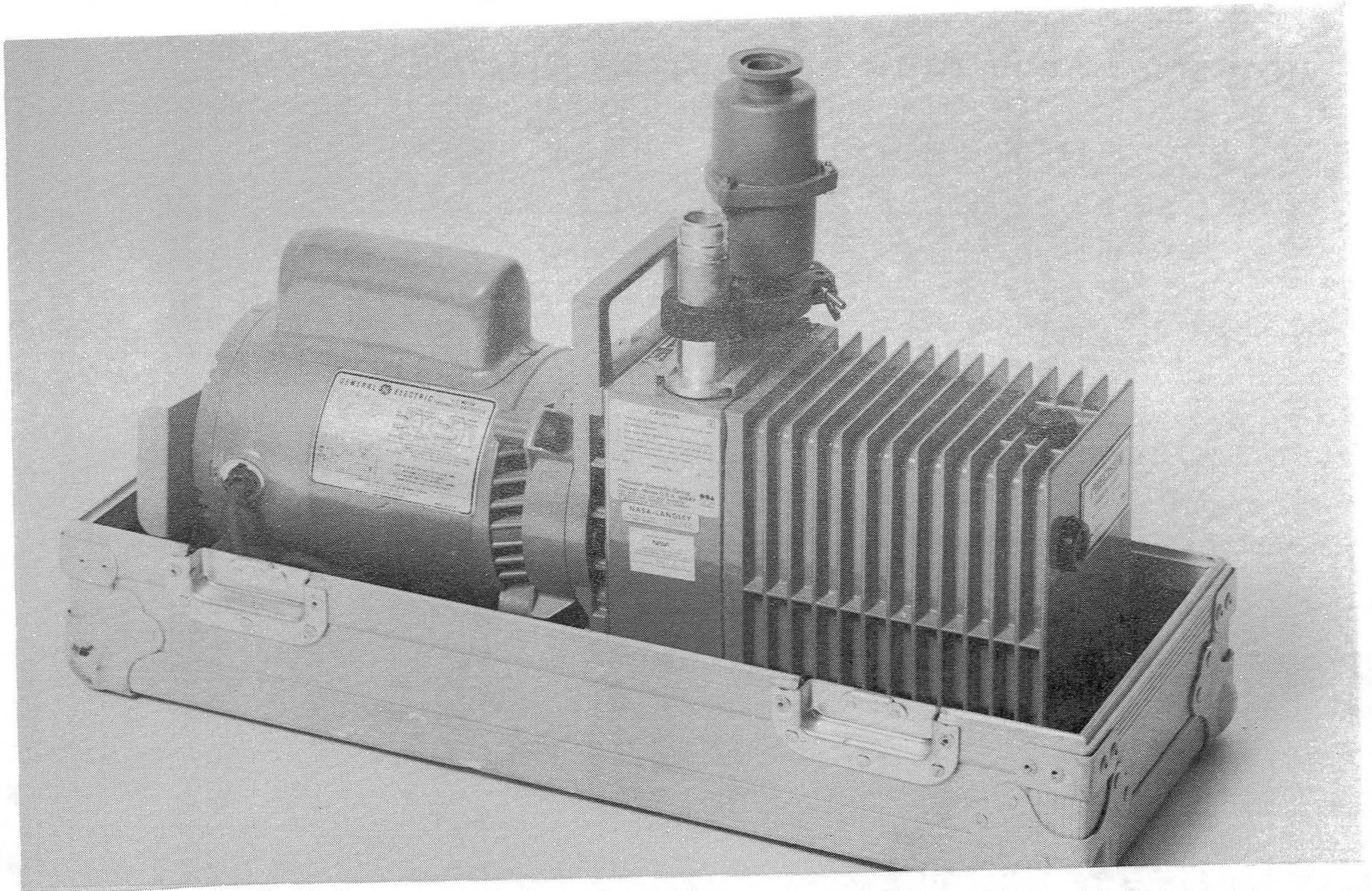

Figure 8—SEADS GTMS Portable Mechanical Pump

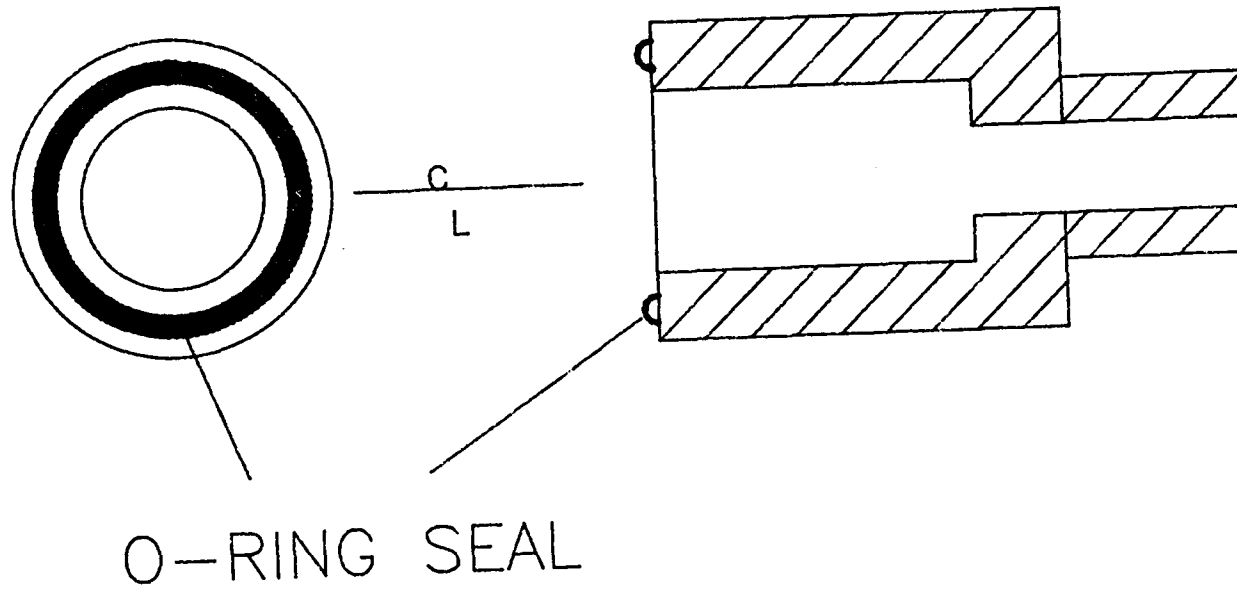

Figure 9-SEADS GTMS Vacuum Seal Orifice
Connector Design

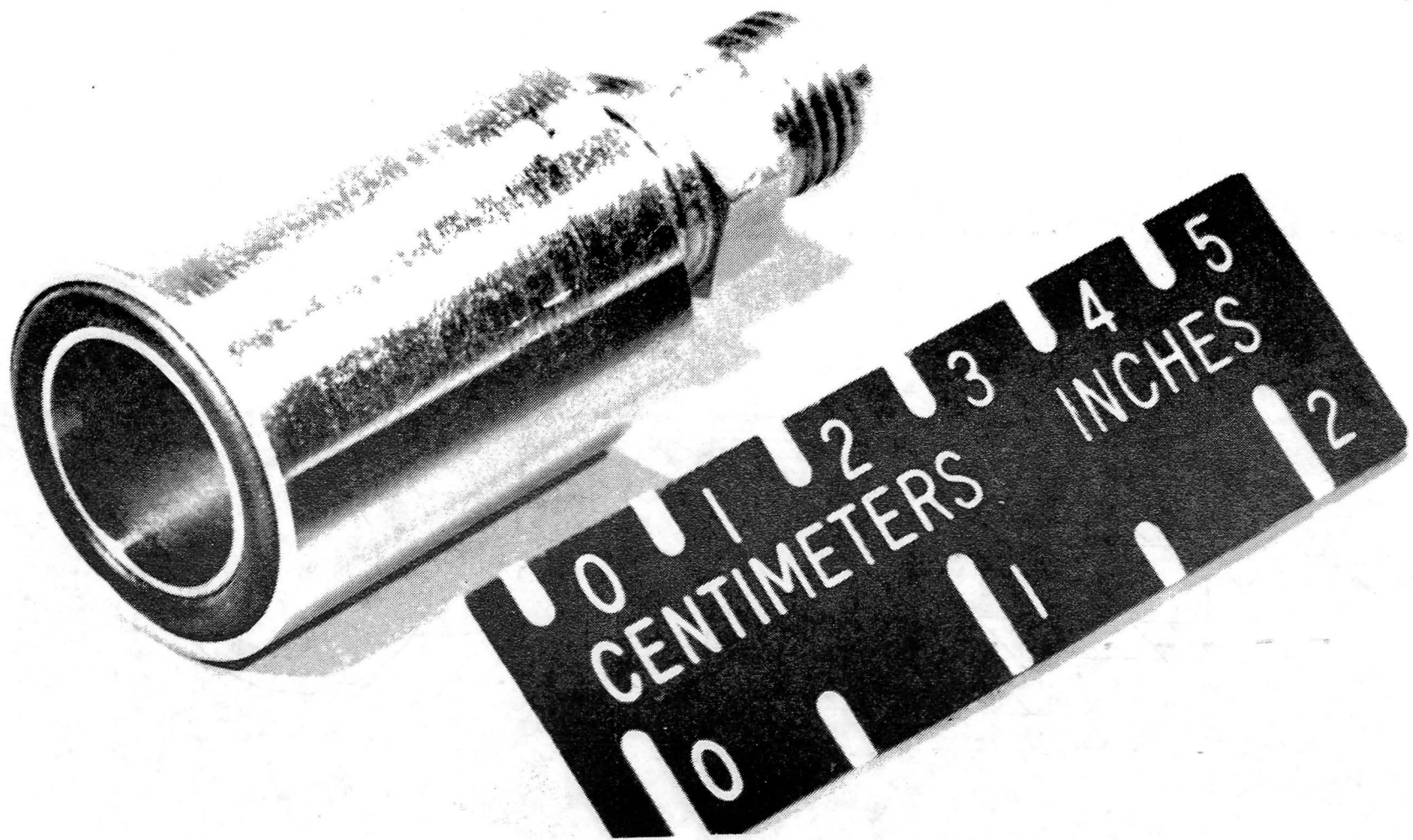

Figure 10—SEADS GTMS Vacuum Seal Orifice Connector

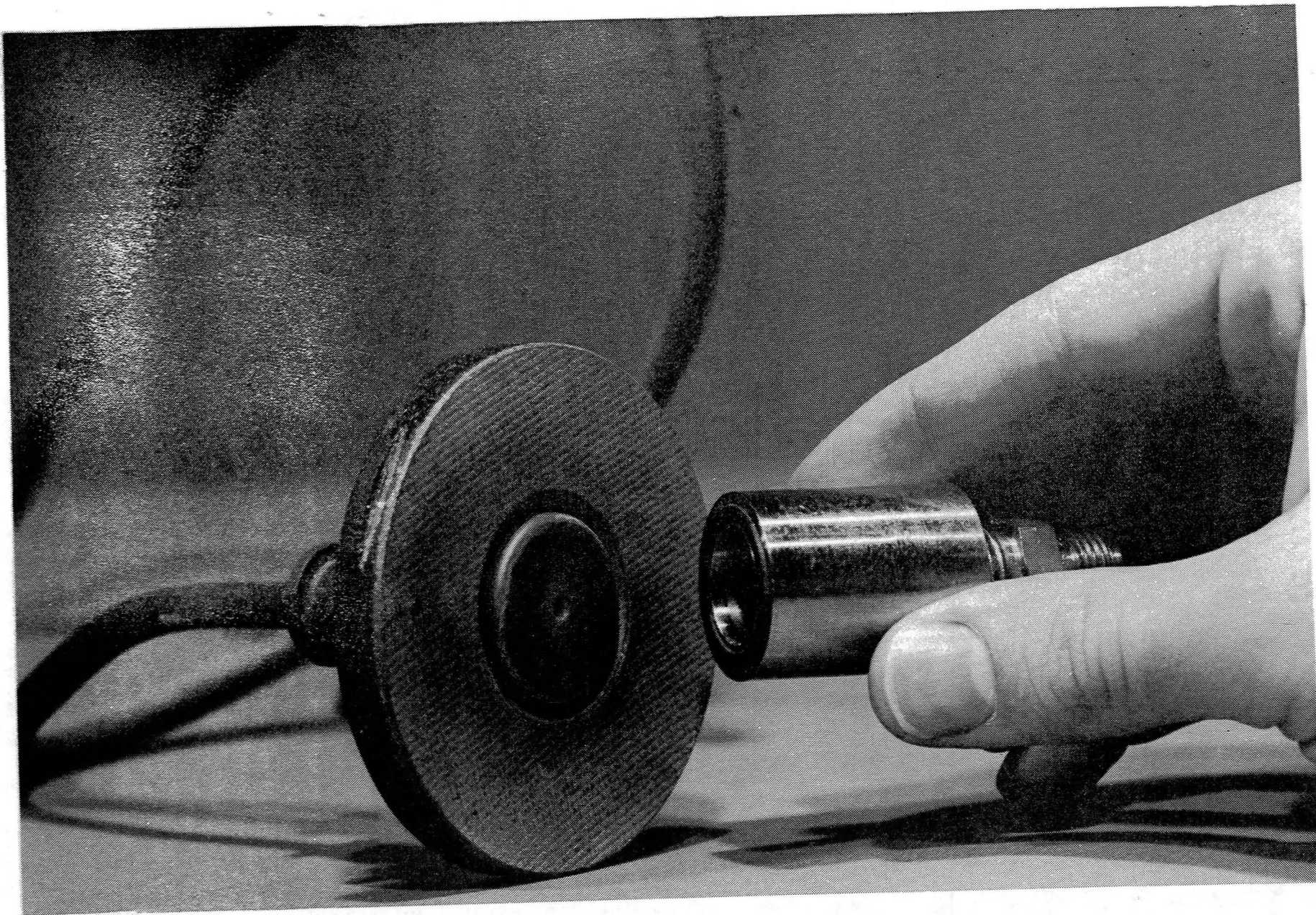

Figure 11-SEADS Orifice Specimen and Connector

1. Report No. NASA TM-85707		2. Government Accession No.		3. Recipient's Catalog No.	
4. Title and Subtitle A Ground Test Measurement System for the Shuttle Entry Air Data System				5. Report Date October 1983	
				6. Performing Organization Code 506-63-32-01	
7. Author(s) Paul C. Schutte				8. Performing Organization Report No.	
9. Performing Organization Name and Address Langley Research Center National Aeronautics and Space Administration Hampton, VA 23665				10. Work Unit No.	
				11. Contract or Grant No.	
				13. Type of Report and Period Covered Technical Memorandum	
12. Sponsoring Agency Name and Address National Aeronautics and Space Administration Washington, DC 20546				14. Sponsoring Agency Code	
15. Supplementary Notes					
16. Abstract The Ground Test Measurement System (GTMS) for determining vacuum decay leak rate within the orifice tubing assembly of SEADS is described. The system can also monitor the absolute pressure in the tubing assembly under certain conditions. The GTMS determines leak rate by measuring vacuum-pressure decay which can be converted into leakage flow rate. Results of performance testing and operation of the GTMS are given.					
17. Key Words (Suggested by Author(s)) Ground Support Equipment Shuttle Entry Air Data System Calibration Pressure Leak Rate Detection				18. Distribution Statement Unclassified - Unlimited Subject Category - 14	
19. Security Classif. (of this report) UNCLASSIFIED		20. Security Classif. (of this page) UNCLASSIFIED		21. No. of Pages 28	22. Price A03

