

General Disclaimer

One or more of the Following Statements may affect this Document

- This document has been reproduced from the best copy furnished by the organizational source. It is being released in the interest of making available as much information as possible.
- This document may contain data, which exceeds the sheet parameters. It was furnished in this condition by the organizational source and is the best copy available.
- This document may contain tone-on-tone or color graphs, charts and/or pictures, which have been reproduced in black and white.
- This document is paginated as submitted by the original source.
- Portions of this document are not fully legible due to the historical nature of some of the material. However, it is the best reproduction available from the original submission.

NASA
Technical Memorandum 83523

AVRADCOM
Technical Report 83-C-9

(NASA-TM-83523) SPECIAL CASES OF FRICTION
AND APPLICATIONS (NASA) 18 p HC A02/MF A01
CSCL 20K

N84-11500

Unclas
G3/37 42459

Special Cases of Friction and Applications

Faydor L. Litvin
University of Illinois at Chicago
Chicago, Illinois

and

John J. Coy
Propulsion Laboratory
AVRADCOM Research and Technology Laboratories
Lewis Research Center
Cleveland, Ohio



Prepared for the
Design Engineering Show and Conference
sponsored by the American Society of Mechanical Engineers
Chicago, Illinois, March 26-29, 1984

NASA



SPECIAL CASES OF FRICTION AND APPLICATIONS

Faydor L. Litvin*
University of Illinois at Chicago
Chicago, Illinois 60680

and

John J. Coy*
Propulsion Laboratory
AVRADCOM Research and Technology Laboratories
Lewis Research Center
Cleveland, Ohio 44135

ABSTRACT

Two techniques for reducing friction forces are presented. The techniques are applied to the generalized problem of reducing the friction between kinematic pairs which connect a moveable link to a frame. The basic principles are: (1) Let the moveable link be supported by two bearings where the relative velocities of the link with respect to each bearing are of opposite directions. Thus the resultant force (torque) of friction acting on the link due to the bearings is approximately zero. Then, additional perturbation of motion parallel to the main motion of the moveable link will require only a very small force; (2) Let the perturbation in motion be perpendicular to the main motion. Equations are developed which explain these two methods. The results are discussed in relation to friction in geared couplings, gyroscope gimbal bearings and a rotary conveyer system. Design examples are presented.

INTRODUCTION

Friction serves a dual role in machines. It can enhance performance or degrade performance. For example, friction forces are a benefit and necessary for the correct operation of such machines as belt drives and clutches. However, machinery wearout, poor efficiency of power transfer, and dynamic instability problems are directly linked to poor control of friction forces.

The physical fundamentals of friction have been discussed in the excellent reference works by Bowden and Tabor [1,2]. The practical aspects of friction must also be understood by designers of machinery. The practical importance of friction in the design and analysis of geared couplings is discussed by Crease [3], Calistrat [4], and Kirk, Mondy, and Murphy [5]. A clever application of a friction principle by the Sperry Gyroscope Company made it possible to minimize the random drift in gyroscopes [6]. In another design application, rotary kilns for the manufacture of portland cement, friction has been overcome by rotating the kiln. Therefore, the raw materials may be easily moved through the slightly tilted kiln by gravity forces [7].

The aforementioned special cases of controlling frictional phenomena may be unified by an explanation of the underlying theory presented in this paper. It is the purpose of this paper to explain two basic principles that may be used in machine design to reduce or control friction. Also, examples of machines are described which illustrate the fundamental theory. They have been built as demonstration and teaching aids to illustrate the two basic principles used to reduce friction.

*Member ASME.

NOMENCLATURE

\underline{F}	friction force vector, N (lb)
\underline{M}	moment vector, N-M (lb-ft)
\underline{P}	force vector, N (lb)
\underline{I}	loading force vector, N (lb)
\underline{v}	velocity vector, M/s (ft/sec)
$[u,v,w], [\underline{e}_u, \underline{e}_v, \underline{e}_w]$	cartesian coordinate system and associated unit vectors
$[x,y,z], [\underline{i}, \underline{j}, \underline{k}]$	cartesian coordinate system and associated unit vectors
α, λ	angles, radians
ω	angular velocity vector, radians/sec
Subscripts:	
f	friction
min	minimum
res	resultant
rot	rotation
s	shaft
tr	translation

TWO WAYS TO REDUCE FRICTION FORCES

Imagine a mechanism consisting of a movable link connected to a frame by identical kinematic pairs. Assume that the link rotates or translates relative to the frame, and that the link is loaded with the force \underline{I} . The first way of reducing the friction which resists the motion of the loaded link is as follows: Arrange the design so that the relative velocities of the link with respect to each kinematic pair are equal in magnitude and opposite in direction. Consequently the friction forces or torques are also equal in magnitude and opposite in direction. Therefore, the resultant friction force is near zero. Then, additional parallel motion perturbation of the link is theoretically frictionless. The second way to reduce the friction is based on moving the link (perturbation) in a direction perpendicular to the main motion. These two principles were described by Jukovsky near the turn of the 20th century, in a reference which is no longer available. Litvin describes this work in Ref. [8]. These two principles will be further developed with design examples and accompanying equations.

PARALLEL MOTION

As an example for design application of the first way to reduce the friction forces that resist motion, consider a heavy block that is to be conveyed along a support of n tightly stretched wires, Fig. 1. Assume the load \underline{I} is uniformly distributed among the wires. The number of wires is evenly divisible by 4. Wire numbers $i = 1, 4, 5,$ and 8 move in one direction, wire numbers $j = 2, 3, 6$ and 7 in the opposite direction. In Fig. 2 the forces of the wires

on the block are shown. The forces due to kinetic friction are F_i and F_j which are equal in magnitude. The kinetic friction forces cancel one another because of their opposite direction. Thus, the loaded block may be translated along the wires by a very small force P . Although the block can be translated with an extremely small apparent coefficient of friction, this does not mean that energy is saved by the conveyor system. Additional energy is required to move the wires in opposite directions against the friction forces F_i and F_j .

As another illustration of applying the first principle to reduce friction in a line moving with respect to a frame, consider Fig. 3. A shaft is supported in two bearings. The shaft is loaded by the force I . Each bearing supports one half of the force I . When the shaft rotates in the bearings with speed ω_s , each bearing exerts a frictional drag moment on the shaft as shown in the free-body diagram, Fig. 4. The frictional moments are equal and each opposes the shaft rotation. The total friction moment which loads the shaft is obtained by summing moments about the shaft axis.

$$M = M_f + M_f = 2M_f \quad (1)$$

M is the moment which is needed to rotate the shaft.

Now suppose that the bearings are not at rest but rotate in opposite directions with equal speed, Fig. 5. Assume that the shaft rotates at a speed, ω_s , that is substantially slower than the speed of the bearings, ω . Therefore, $\omega_s \ll \omega$, and the angular velocity of the shaft with respect to each bearing is

$$\omega_{12} = \omega_s - \omega \approx -\omega \quad (2a)$$

$$\omega_{13} = \omega_s - (-\omega) \approx \omega \quad (2b)$$

As before, the frictional moments of the bearings that are exerted on the shaft are equal in magnitude, and they oppose the relative motion of the shaft with respect to the bearings, Fig. 6. But in this case the frictional moments are opposite in direction, and the total frictional moment is theoretically zero.

$$M = -M_f + M_f = 0 \quad (3)$$

Therefore, the shaft may be rotated by applying a very small driving torque. The apparent frictional torque has been reduced for the shaft, but an additional source of energy is required to rotate the bearings.

The effect of reducing the frictional moment may be demonstrated with the model shown in Fig. 7. Litvin, Rybakov, and Udalov originated the model, a description of which is given in Ref. [9]. The pendulum is rigidly connected to the shaft. The pendulum is set in motion while the bearings are at rest and the time for the pendulum to come to rest is determined. The time for the pendulum to stop is used as a measure of the frictional damping in the bearing support system. The experiment is performed again while the bearings are rotated in opposite directions. The ratio of the two times may be considered as characteristic of the reduction in the moment of friction.

This method of reducing friction was used by Sperry in an invention applied to the gimbal support bearings in gyroscopes [6]. The gyroscope random drift rate was greatly reduced by this invention.

The friction principle as described is the basis for understanding the action of gear-type couplings which connect misaligned shafts, Fig. 8. The coupling assembly is shown in the misaligned condition. As the coupling rotates, the hub teeth slide relative to the sleeve. When one tooth shifts from left to right, the diametrically opposite tooth shifts from right to left. The axially directed friction forces cancel each other. This is true for all teeth around the hubs at each end. The cancelling of the friction forces allows the assembly of two sleeves plus the spacer to float frictionlessly on the hubs. If the shafts are very carefully aligned, it is possible to transmit large axial thrust forces through the coupling when thermal growth occurs. Many thrust bearings have failed due to this effect [3]. Calistrat has successfully investigated the problem of how various parameters affect the apparent coefficient of friction in couplings [4].

PERPENDICULAR MOTION

The second way to reduce friction is to move the link in a direction perpendicular to the main motion. As a simple example, a tight-fitting finger-ring is more easily removed if it is quickly rotated even as it is slowly translated along the finger. For another example, a car often moves sideways when the driver accelerates sharply on a slippery street. The slipping occurs due to force acting on the car wheels in the direction of their axles. This force is induced by the wheel misalignment or by the force of gravity which acts when the street is not level.

An expression for the relation between friction force and motion in the perpendicular direction is developed next.

Consider the block shown in Fig. 9 which is placed on a rough plane and loaded with the force \underline{I} . Assume that the block is moving in the x -direction with a constant velocity, V_x , under the influence of the applied force P_x . Then the force P_y is applied in the direction perpendicular to P_x . This causes the block to have an additional motion, parallel to the y -axis, with the velocity V_y ($V_x = \text{const}$). The resultant motion is along a straight line which forms the angle λ with the x axis, Fig. 10.

$$\lambda = \tan^{-1} \frac{V_y}{V_x} \quad (4)$$

The force of friction which acts to restrain the block is directed opposite to the resultant velocity \underline{V} . The magnitude of the friction force \underline{F} is determined by the loading force \underline{I} and the coefficient of kinetic friction, μ_k , as given by the following equation.

$$F = \mu_k T \quad (5)$$

The friction force is sufficient to balance the causitive forces P_x and P_y if the block is assumed to be in steady motion (no acceleration).

$$\underline{F} = P_x \underline{i} + P_y \underline{j} \quad (6)$$

where

$$P_x = F \cos \lambda$$

$$P_y = F \sin \lambda \quad (7b)$$

If it is assumed that the velocity V_y is small in comparison to V_x , then the following approximation is true.

$$\sin \lambda \approx \tan \lambda \approx \frac{V_y}{V_x} \quad (8)$$

Then the force magnitude in the y-direction may be expressed as

$$P_y \approx F \frac{V_y}{V_x} \approx \mu_k T \frac{V_y}{V_x} \quad (9)$$

Or, expressing the force as proportional to velocity, the expression may be written as

$$P_y = kV_y \quad (10)$$

where

$$k = \frac{\mu_k T}{V_x} \quad (11)$$

Equation (10), where friction force is proportional to velocity, is the same form as the equation for friction force when a thin film of lubricant separates the moving body from the rough plane. The foregoing results were obtained even though dry friction existed between the block and the rough plane. The resulting equation shows that while the block moves in the x-direction with a given velocity, only a very small force is necessary to move the block in the y-direction. This results from the observation on Eq. (10) that when V_y is almost zero, so also is P_y . Thus, the second principle of how to reduce friction forces between a moving link and a frame has been explained.

As a further example of how the force of friction may be reduced, consider the mechanism consisting of a collar that slides on a shaft. This is a common kinematic pair that often occurs in design practice. A practical machine may involve a reciprocating motion of the collar back and forth along the shaft. In the following paragraphs a quantitative description with equations is given for the difference between the friction forces that are obtained when two cases are considered: shaft rotation and no shaft rotation.

A device has been built to demonstrate the principle. Figure 11 shows the mechanism illustrating the principle of the collar moving along the rotating shaft which is motor driven. The shaft inclination with respect to the horizontal direction may be adjusted by loosening the thumbscrew. To obtain a measure of the reduction in friction that opposes the translation of the collar, the shaft is tilted at an angle with respect to the horizontal direction. The angle for which the collar continues to move at a constant velocity under the influence of gravity is a measure of the friction force.

First, consider the case of no shaft rotation. Figure 12 shows a free-body diagram for the forces which act on the collar. An expression for the angle of tilt at which the collar steadily slides down the shaft is desired. The weight of the collar is designated by T . Therefore with a tilt angle $\alpha = \alpha_{min}$ the steady motion will be maintained. If $\alpha < \alpha_{min}$ the collar will stop. From a force balance in the u -direction,

$$F = T \sin \alpha_{min} \quad (12)$$

From the relation between the normal force and friction force according to the law of kinetic friction, the following is true.

$$F = \mu_k T \cos \alpha_{min} \quad (13)$$

From the previous two equations, the following relation between the angle and the friction coefficient results.

$$\alpha_{min} = \tan^{-1} \mu_k \quad (14)$$

This is the minimum angle which allows steady sliding of the collar down the stationary shaft.

Next, consider the case of the collar sliding down a rotating shaft. The free-body diagram of the collar is shown in Fig. 13. Due to rotation of the shaft and translation of the collar, the path traced on the shaft by a point of the collar is a helix with lead angle λ .

$$\lambda = \tan^{-1} \frac{V_{tr}}{V_{rot}} \quad (15)$$

Henceforth we assume that the velocity in rotation, V_{rot} , is greater than the velocity in translation, V_{tr} .

The friction force exerted on the collar by the shaft is directed opposite to the relative velocity. Thus the friction force is also directed along the helix path. Now, consider the force polygon assuming that the motion of the collar is steady. From a force balance in the direction of the shaft axis (u -direction), the following equation is written

$$F \sin \lambda = T \sin \alpha_{rot} \quad (16)$$

From the law of friction, the following equation is true.

$$F = \mu_k T \cos \alpha_{rot} \quad (16a)$$

From the preceding three equations the result for the angle of inclination at which a steady sliding motion is maintained is as follows

$$\alpha_{rot} = \tan^{-1} \left\{ \mu_k V_{tr} / \sqrt{V_{tr}^2 + V_{rot}^2} \right\} \quad (17)$$

ORIGINAL PAGE IS
OF POOR QUALITY

By comparing this result with Eq. (14) which gave the minimum angle for which the collar may slide on a stationary shaft the following conclusion may be made

$$\alpha_{rot} < \alpha_{min} \quad (18)$$

It was assumed that the peripheral speed of the shaft is high relative to the speed of translation of the collar. Thus the equation may be reduced to the following approximate result.

$$\alpha_{rot} \approx \tan^{-1} \left\{ \mu_k \frac{V_{tr}}{V_{rot}} \right\} \quad (19)$$

From this equation it may be concluded that α_{rot} approaches a very small angle as the ratio of sliding velocities V_{tr}/V_{rot} becomes small. Therefore, the friction which resists translation of a collar along a shaft is very much reduced if the shaft is rotated and, in the limit, α_{rot} approaches zero as V_{rot}/V_{tr} approaches infinity.

A second device to demonstrate this principle is shown in Fig. 14. The carriage slides over the two shafts. By virtue of the shaft rotations, which may be in the same or opposite directions, the friction is reduced.

The basic principle has also been used to transport loose materials such as sand through a rotating pipe. The pipe is inclined at some small angle as represented by Eq. (19). A demonstration model of this type of device is shown in Fig. 15. The material is transported through the rotating tube by gravity forces. The feed rate is adjustable by varying either the tube angle or the rotational speed. The material is transported even though the angle is much smaller than the minimum angle for gravity feeding with no shaft rotation, ($\alpha_{rot} \ll \alpha_{min}$). This is the principle of operation of the rotary kilns used in the manufacture of Portland cement [7].

SUMMARY

Two techniques for reducing friction forces have been presented. The explanation of the techniques was based on the premise that friction forces which retard motion between moving parts in machinery can be reduced by a primary relative motion. The moving parts were generalized and represented as a link that moves relative to a frame. The link was assumed connected to the frame by identical kinematic pairs. The two basic concepts for reducing the friction that retards motion of the movable link were described. The following results were obtained.

1. Where the relative velocities of the link with respect to each kinematic pair are equal in magnitude and opposite in sense, the resultant of the friction forces is zero. Therefore, the additional motion of the link parallel to the relative velocity is theoretically frictionless.

2. For the same kinematic arrangement, slow motion in a direction perpendicular to the main motion is also approximately frictionless.

CONCLUDING REMARK

The principles explained in the paper have already been successfully used in gear-type flexible shaft couplings, gyroscope gimbal bearings, and rotary kilns. The paper provides a unifying theoretical and practical focus which may be applied by designers of new machinery.

REFERENCES

1. Bowden, F. P., and Tabor, D., The Friction and Lubrication of Solids, Clarendon Press, Oxford, 1958.
2. Bowden, F. P., and Tabor, D., The Friction and Lubrication of Solids, Part II, Clarendon Press, Oxford, 1964.
3. Crease, A. B., "Gear Couplings for High Powers and Speeds: Advantages, Limitations, and Alternatives," Tribology International, vol. 11, no. 1, Feb., 1978, pp 49-57.
4. Calistrat, M. M., "Friction between High Speed Gear Coupling Teeth," ASME Journal of Mechanical Design, vol. 103, no. 1, Jan., 1981, pp 54-60.
5. Kirk, R. G., Mondy, R. E., and Murphy, R. C., "Instabilities of Geared Couplings - Theory and Practice," Rotordynamic Instability Problems in High-Performance Turbomachinery - 1982, NASA CP-2250, 1982, pp. 58-80.
6. Savet, P. H., editor, Gyroscopes: Theory and Design; With Applications to Instrumentation, Guidance and Control, McGraw-Hill, New York, 1961, pp. 289-292.
7. McGannon, H. E., editor, The Making, Shaping and Treating of Steel, 9th ed., United States Steel, Pittsburgh, 1971, pp 250-252.
8. Litvin, F. L., Design of Mechanisms and Instrument Elements, Mashinostroenie, Leningrad, 1973, pp 48-56, (in Russian).
9. Litvin, F. L., Rybakov, V. I., and Udalov V. A., "Device for Illustration of the Effect of Reduction of Friction in the Bearings," Certificate of Invention No. 436380, U.S.S.R., March 21, 1974, (in Russian).

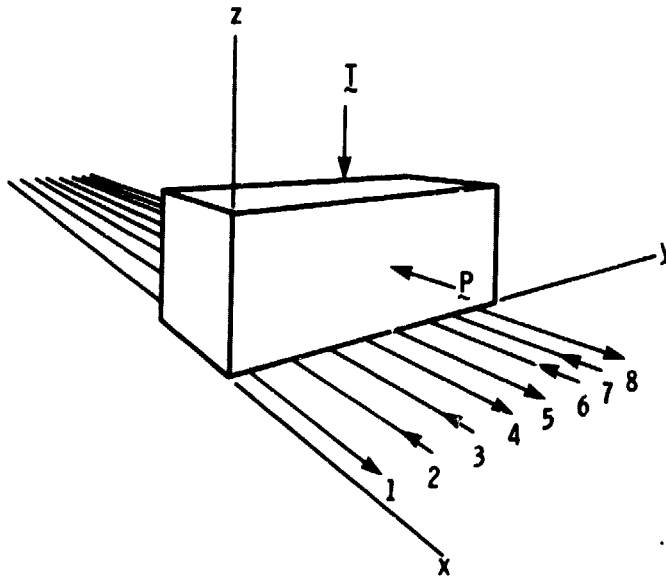

Figure 1. - Block supported by n tightly stretched moving wires.
Block moves without friction in response to force P .

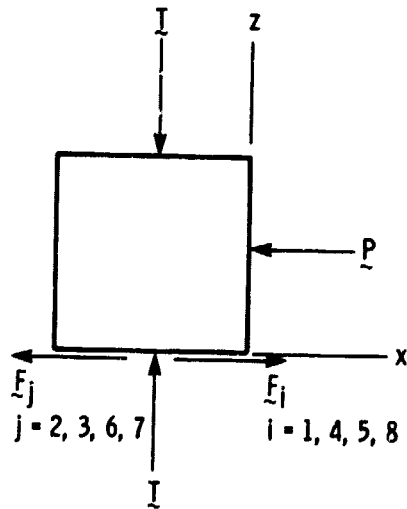

Figure 2. - Free-body diagram of
block.

ORIGINAL PAGE IS
OF POOR QUALITY

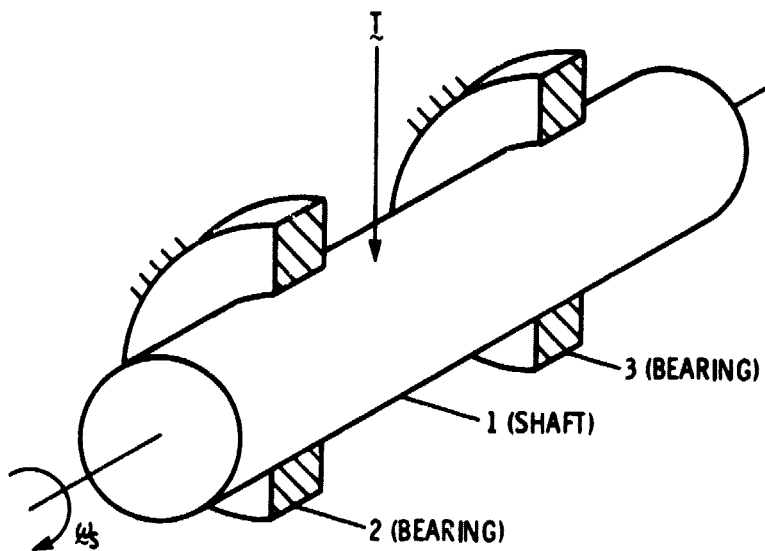

Figure 3. - Shaft supported in two bearings.

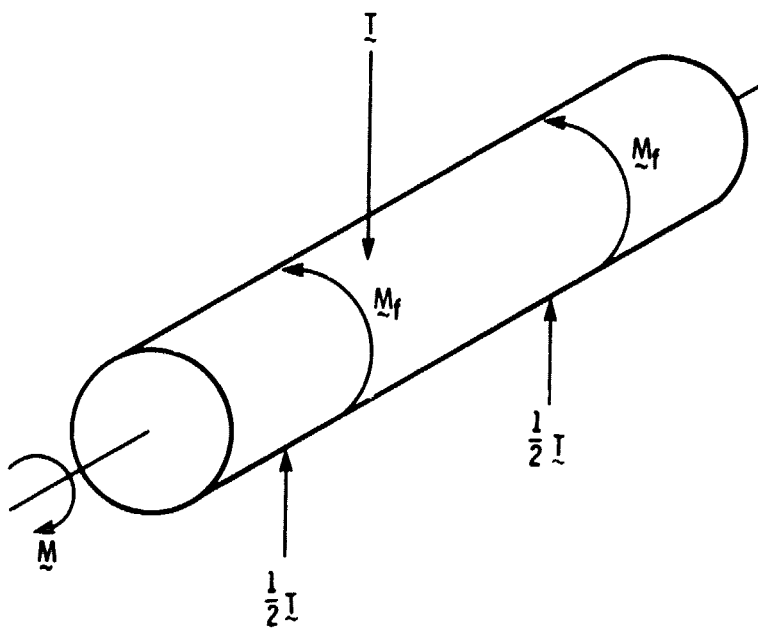

Figure 4. - Free-body diagram of shaft.

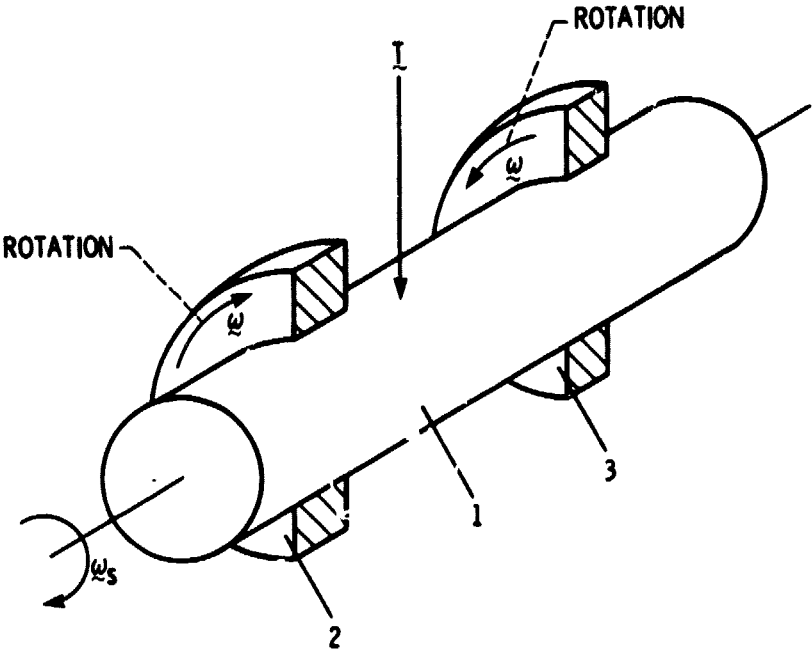

Figure 5. - Shaft supported in counter-rotating bearings.

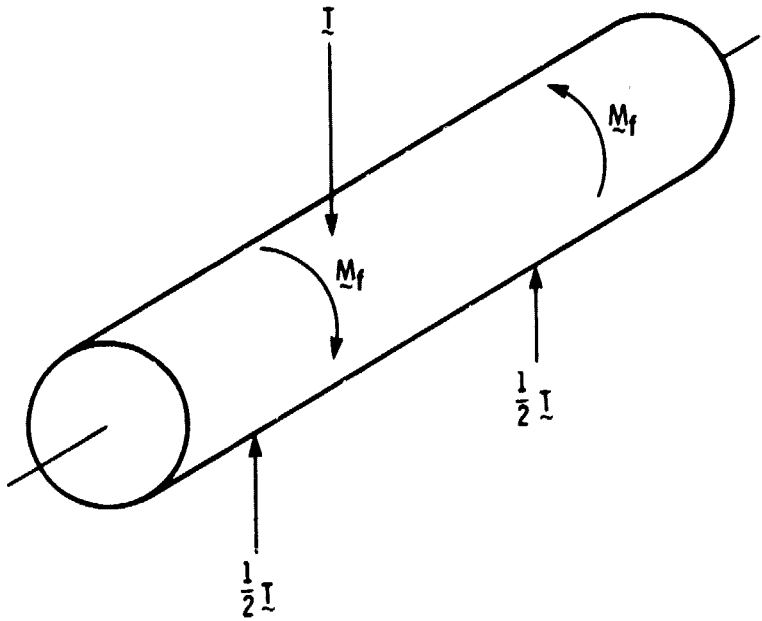

Figure 6. - Free-body diagram of shaft showing opposing friction moments.

ORIGINAL PAGE 13
OF POOR QUALITY

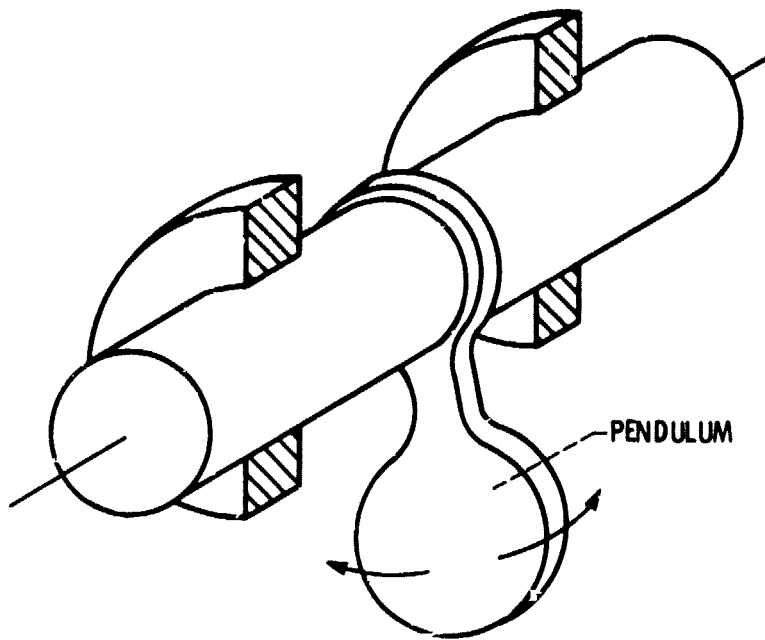

Figure 7. - Pendulum mechanism to demonstrate reduced friction when the bearings are counter-rotated.

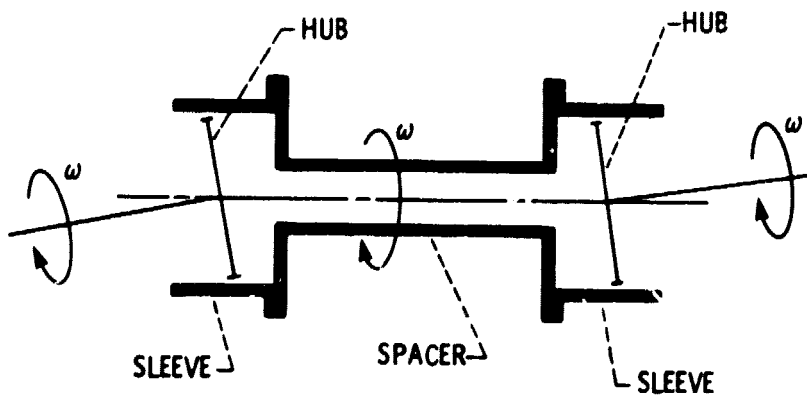

Figure 8. - Schematic of gear-type coupling connected between misaligned shafts.

ORIGINAL PAGE IS
OF POOR QUALITY

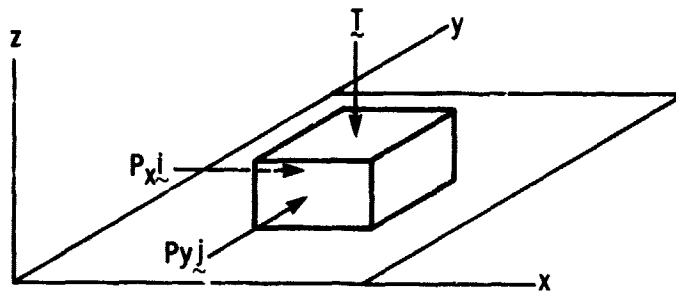

Figure 9. - Block on a rough plane.

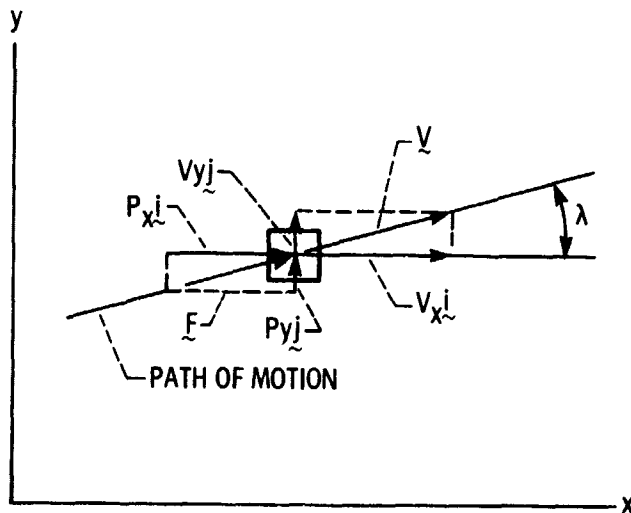

Figure 10. - Top view of block on rough plane showing friction force and path of motion.

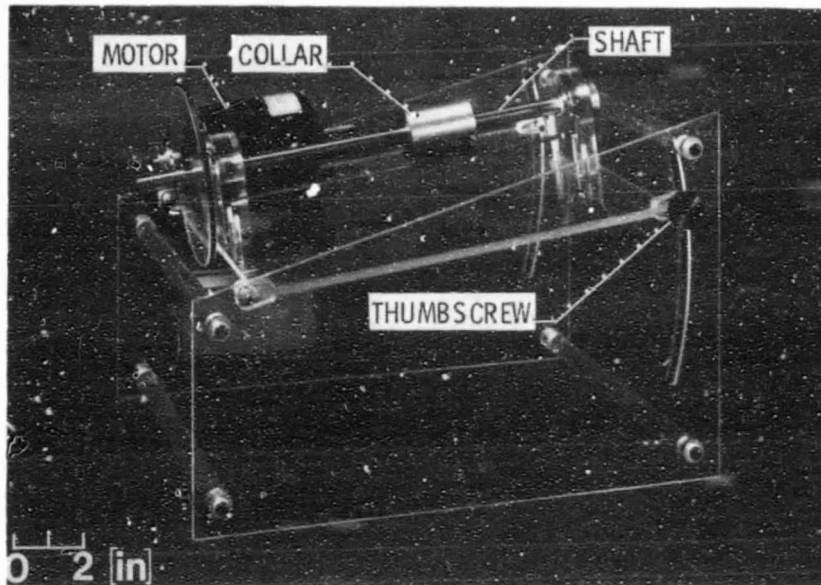

Figure 11. - Photograph of machine to demonstrate reduced friction when the motion of interest is perpendicular to the main motion. Designed by Sherman Towns under the supervision of F. L. Litvin.

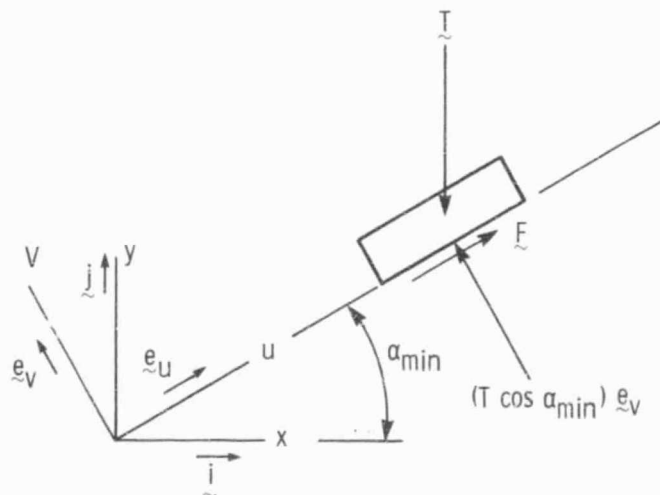

Figure 12. - Free-body diagram for collar sliding down a stationary shaft.

ORIGINAL PAGE IS
OF POOR QUALITY

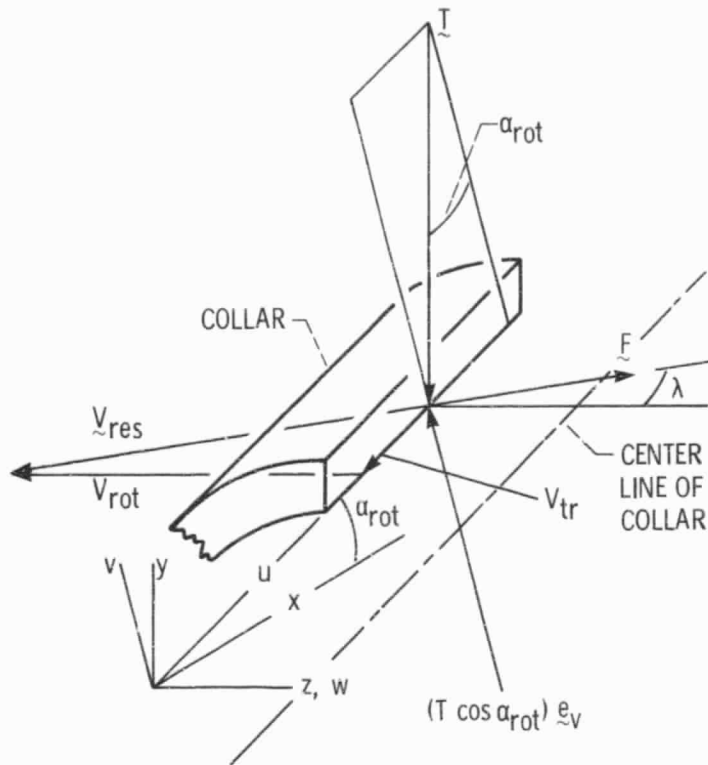

Figure 13. - Free-body diagram for collar sliding down a rotating shaft.

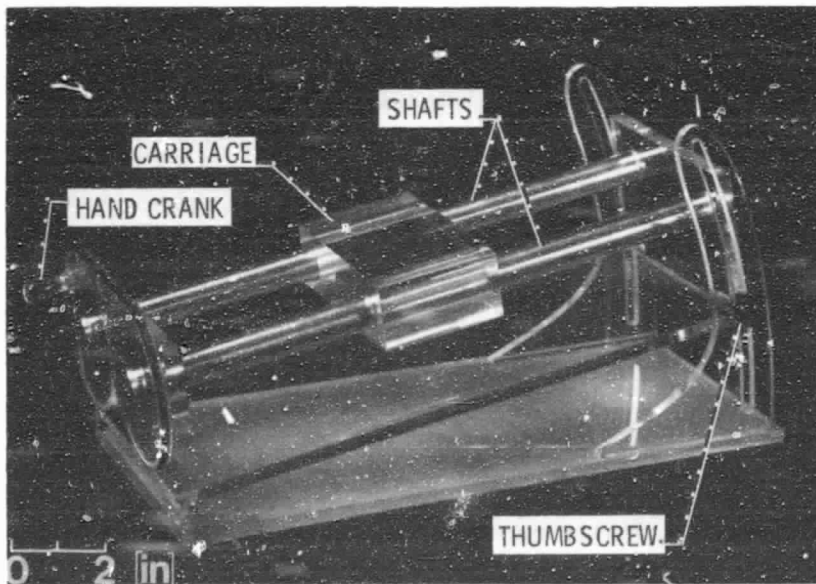

Figure 14. - Photograph of machine to demonstrate reduced friction.

ORIGINAL PAGE IS
OF POOR QUALITY

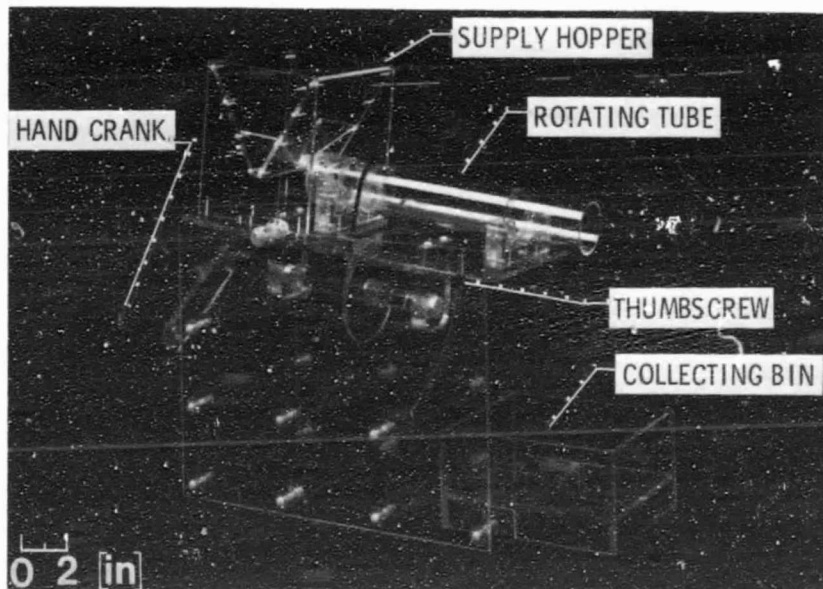

Figure 15. - Photograph of rotating tube conveyor. Demonstrates principal of reduced friction. Designed by T. Waterstaat, P. Giangnorio, M. Lenz and M. Schwerha under the supervision of F. L. Litvin.