

General Disclaimer

One or more of the Following Statements may affect this Document

- This document has been reproduced from the best copy furnished by the organizational source. It is being released in the interest of making available as much information as possible.
- This document may contain data, which exceeds the sheet parameters. It was furnished in this condition by the organizational source and is the best copy available.
- This document may contain tone-on-tone or color graphs, charts and/or pictures, which have been reproduced in black and white.
- This document is paginated as submitted by the original source.
- Portions of this document are not fully legible due to the historical nature of some of the material. However, it is the best reproduction available from the original submission.

DRA



PERFORMANCE ANALYSIS OF A
CONCATENATED CODING SCHEME FOR ERROR CONTROL

Technical Report

to

NASA
Goddard Space Flight Center
Greenbelt, Maryland

(NASA-CR-175345) PERFORMANCE ANALYSIS OF A
CONCATENATED CODING SCHEME FOR ERROR CONTROL
(Illinois Inst. of Tech.) 15 p
HC A02/MF A01

N84-16422

CSSL 17B

G3/32 Unclas
15205

Grant Number NAG 5-234

Principal Investigators

Daniel J. Costello, Jr.
Department of Electrical Engineering
Illinois Institute of Technology
Chicago, Illinois 60616

Shu Lin
Department of Electrical Engineering
University of Hawaii at Manoa
2540 Dole Street
Honolulu, Hawaii 96822

September 6, 1983

PERFORMANCE ANALYSIS OF A
CONCATENATED CODING SCHEME FOR ERROR CONTROL

Tadao Kasami
Osaka University
Toyonaka, Japan

Shu Lin
University of Hawaii at Manoa
Honolulu, Hawaii 96822

ABSTRACT

In this paper, a concatenated coding scheme for error control in data communications is analyzed. In this scheme, the inner code is used for both error correction and detection, however the outer code is used only for error detection. A retransmission is requested if the outer code detects the presence of errors after the inner code decoding. Probability of undetected error is derived and bounded. A particular example, proposed for NASA Planetary Program, is analyzed.

1. Introduction

Consider a concatenated coding scheme for error control for a binary symmetric channel with bit-error-rate $\epsilon < 1/2$ as shown in Figure 1. Two linear block codes, C_f and C_b , are used. The inner code C_f , called frame code, is an (n, k) code with minimum distance d_f . The frame code is designed to correct t or fewer errors and simultaneously detect λ ($\lambda > t$) or fewer errors where $t + \lambda + 1 \leq d_f$. The outer code C_b is an (n_b, k_b) code with

$$n_b = mk .$$

The outer code is designed for error detection only.

The encoding is done in two stages. A message of k_b bits is first encoded into a codeword of n_b bits in the outer code C_b . Then the n_b -bit word is divided into m k_b -bit segments. Each k_b -bit segment is encoded into an n -bit word in the frame code C_f . This n -bit word is called a frame. Thus, corresponding to each k_b -bit message at the input of the outer code encoder, the output of the frame code encoder is a sequence of m frames. This sequence of m frames is called a block. A two dimensional block format is depicted in Figure 2.

The decoding consists of error correction in frames and error detection in m decoded k_b -bit segments. When a frame in a block is received, it is decoded based on the frame code C_f . The $n-k$ parity bits are then removed from the decoded frame, the k -bit decoded segment is stored in a buffer. If there are t or fewer transmission errors in a received frame, the errors will be corrected and the decoded segment is error free. If there are more than t errors in a received frame, the decoded segment contains undetected errors. After m frames of a block have been decoded, the buffer contains m k_b -bit decoded segments. Then error detection is performed on these m decoded segments based on the outer code C_b . If no error is detected, the m decoded segments are assumed to be error free and are accepted (with the $n_b - k_b$ parity bits removed) by the receiver. If

the presence of errors is detected, the m decoded segments are discarded and the receiver requests a retransmission of the rejected block. Retransmission and decoding process continues until a transmitted block is successfully received. Note that a successfully received block may be either error free or contains undetectable errors.

The error control scheme described above is actually a combination of forward-error-correction (FEC) and automatic-repeat-request (ARQ), called a hybrid ARQ scheme [1]. The retransmission strategy determines the system throughput, it may be one of the three basic modes namely, stop-and-wait, go-back-N or selective-repeat. In this report, we are only concerned with the reliability of the proposed error control scheme. The reliability is measured in terms of the probability of undetected error after decoding.

An example scheme, proposed for NASA Planetary Program, is analyzed.

2. Probability of Undetected Error for the Frame Code

For a codeword \bar{v} in the frame code C_f , let $w(\bar{v})$, $w^{(1)}(\bar{v})$ and $w^{(2)}(\bar{v})$ denote the weight of \bar{v} , the weight of information-part of \bar{v} and the weight of parity-part of \bar{v} respectively. Clearly $w(\bar{v}) = w^{(1)}(\bar{v}) + w^{(2)}(\bar{v})$. If a decoded frame contains an undetectable error pattern, this error pattern must be a nonzero codeword in C_f . Let \bar{e}_0 be a nonzero error pattern after decoding. Since \bar{e}_0 is in C_f , we have

$$w^{(1)}(\bar{e}_0) + w^{(2)}(\bar{e}_0) \geq d_f, \quad (1)$$

and

$$w^{(1)}(\bar{e}_0) \geq 1. \quad (2)$$

The probability $P_f(\bar{e}_0, \epsilon)$ that a decoded frame contains a nonzero error vector \bar{e}_0 after decoding is given by [2],

$$P_f(\bar{e}_0, \epsilon) = \sum_{i=0}^t \sum_{j=0}^{\min(t-i, n-w)} \binom{w}{i} \binom{n-w}{j} \epsilon^{w-i+j} (1-\epsilon)^{n-w+i-j}, \quad (3)$$

where $w = w(\bar{e}_0)$.

Let $P_{ud}^{(f)}(\epsilon)$ denote the probability of undetected error for the frame code. Let $\{A_w^{(f)}, 0 \leq w \leq n\}$ be the weight distribution of C_f where $A_w^{(f)}$ denotes the number of codewords in C_f with weight w . Then, it follows from (3) that

$$P_{ud}^{(f)}(\epsilon) = \sum_{w=0}^n A_w^{(f)} \sum_{i=0}^t \sum_{j=0}^{\min(t-i, n-w)} \binom{w}{i} \binom{n-w}{j} \epsilon^{w-i+j} (1-\epsilon)^{n-w+i-j}. \quad (4)$$

Hence, if we know the weight distribution of the frame code, we can compute $P_{ud}^{(f)}(\epsilon)$ from (4).

Let $Q_t(w, \epsilon)$ denote the right-hand side of (3). For $w \leq n-1-j$,

$$\frac{\binom{w+1}{i} \binom{n-w-1}{j} \epsilon^{w+1-i+j} (1-\epsilon)^{n-w-1+i-j}}{\binom{w}{i} \binom{n-w}{j} \epsilon^{w-i+j} (1-\epsilon)^{n-w+i-j}} = \frac{(w+1)(n-w-j)\epsilon}{(w+1-i)(n-w)(1-\epsilon)} \leq \frac{(w+1)\epsilon}{(w+1-t)(1-\epsilon)}. \quad (5)$$

Since $w \geq 2t+1$, we have that

$$\frac{w+1}{w+1-t} \leq \frac{2t+2}{t+2}. \quad (6)$$

It follows from (5) and (6) that, for $\epsilon \leq \frac{t+2}{3t+4}$,

$$Q_t(w+1, \epsilon) \leq Q_t(w, \epsilon). \quad (7)$$

For $1 \leq i \leq k$, let

$$W(i) = \min\{w(\bar{v}) : \bar{v} \in C_f \text{ and } w^{(1)}(\bar{v}) = i\}. \quad (8)$$

Then we see readily that

$$W(i) \geq \max(d_f, i). \quad (9)$$

If C_f is an even-weight code and i is odd, then

$$W(i) \geq \max(d, i+1). \quad (10)$$

It follows from (3), (7) and (9) that, for $0 \leq \epsilon \leq (t+2)/(3t+4)$,

$$P_f(\bar{e}_0, \epsilon) \leq Q_t(W(w^{(1)}(\bar{e}_0)), \epsilon) \leq Q_t(\max(d_f, w^{(1)}(\bar{e}_0)), \epsilon). \quad (11)$$

For $\epsilon \ll 1/n$, we can see from (3) and (11) that

ORIGINAL PAGE IS
OF POOR QUALITY

$$P_f(\bar{e}_0, \epsilon) \leq \begin{cases} \binom{d_f}{t} \epsilon^{d-t} (1-\epsilon)^{n-d_f+t} & \text{for } w^{(1)}(\bar{e}_0) < d, \\ \binom{w^{(1)}(\bar{e}_0)}{t} \epsilon^{w^{(1)}(\bar{e}_0)-t} (1-\epsilon)^{n-w^{(1)}(\bar{e}_0)+t}, & \text{otherwise.} \end{cases} \quad (12)$$

3. Probability of Undetected Error for the Outer Code

Recall that a codeword in the outer code C_b consists of m k -bit segments. At the receiver, error detection is performed on every m decoded segments based on C_b . Let $P_b(\bar{e}, \epsilon)$ denote the probability that the decoded word contains an undetectable error pattern \bar{e} (a nonzero codeword in C_b). For a nonzero codeword \bar{v} in C_b , we define the weight configuration of \bar{v} as the sequence of nonzero weights of component segments of \bar{v} , arranged in ascending order. For an undetectable error pattern \bar{e} with weight configuration (i_1, i_2, \dots, i_h) , it follows from (11) that

$$P_b(\bar{e}, \epsilon) \leq \prod_{\ell=1}^h Q_t(W(i_\ell), \epsilon) [1 - P_{ud}^{(f)}(\epsilon)]^{m-h}. \quad (14)$$

It follows from (12), (13) and (14) that the power of ϵ in the right-hand side of (14) is

$$\sum_{\ell=1}^h W(i_\ell) - th. \quad (15)$$

Suppose that the frame code C_f is an even-weight code. For any positive integer i , define $W'(i)$ as follows:

$$\begin{cases} W'(i) = d, & \text{if } i \leq d_f; \\ W'(i) = i, & \text{if } i > d_f \text{ and } i \text{ is even;} \\ W'(i) = i+1, & \text{otherwise.} \end{cases} \quad (16)$$

For an error pattern \bar{e} of weight configuration (i_1, i_2, \dots, i_h) , define the order $O_\epsilon(\bar{e})$ of \bar{e} as follows:

$$O_\epsilon(\bar{e}) = \sum_{\ell=1}^h W'(i_\ell) - th. \quad (17)$$

If $0_\epsilon(\bar{e}) > w(\bar{e})$, we say that \bar{e} has a good weight configuration and \bar{e} is a good error pattern. On the other hand, if $0_\epsilon(\bar{e}) < w(\bar{e})$, \bar{e} is said to be a bad error pattern.

Let $P_{ud}^{(b)}(\epsilon)$ be the probability of undetected error for the outer code C_b . In order to obtain a good evaluation of $P_{ud}^{(b)}(\epsilon)$, we need to estimate the proportion of bad error patterns and that of good error patterns to the error patterns of the same weight for several low weights. Unless the former is negligibly smaller than the latter, the error correction of the frame code does not make sense.

For $1 \leq j_1 < j_2 < \dots < j_h \leq m$, consider the set of codewords in C_b where nonzero bits are confined in j_1 -th segment, j_2 -th segment, ..., and the j_h -th segment. This set of codewords forms a subcode of C_b , called a (j_1, j_2, \dots, j_h) -subcode of C_b . If C_b is a cyclic or shortened cyclic code, all (j_1, j_2, \dots, j_h) -subcodes of C_b for a given h with the same $j_2 - j_1, j_3 - j_2, \dots, j_h - j_{h-1}$ are equivalent codes and are called h -segment $(j_2 - j_1, j_3 - j_2, \dots, j_h - j_{h-1})$ subcodes of C_b .

Consider a (j_1, j_2, \dots, j_h) -subcode of C_b . Let i_1, i_2, \dots, i_h be a set of integers for which $0 \leq i_\ell \leq n$ with $1 \leq \ell \leq h$. Let $A_{i_1, i_2, \dots, i_h}^{j_1, j_2, \dots, j_h}$ denote the number of codewords in the (j_1, j_2, \dots, j_h) -subcode whose weight in the j_ℓ -th segment is i_ℓ for $1 \leq \ell \leq h$. If we know segment-weight distributions for all h -segment subcodes of C_b , we can obtain an upper bound on $P_{ud}^{(b)}(\epsilon)$ from (14). If $\epsilon \ll 1/n_b$, a small h is sufficient to attain a good evaluation of $P_{ud}^{(b)}(\epsilon)$. This will be illustrated by an example in the next section.

4. Examples

Consider the concatenated coding scheme proposed for the NASA planetary command system in which both the inner (frame) code and outer code are shortened Hamming codes. The frame code C_f is a distance-4 Hamming code with generator polynomial,

$$\bar{g}(X) = (X+1)(X^6+X+1) = X^7+X^6+X^2+1 ,$$

where X^6+X+1 is a primitive polynomial of degree 6. The maximum length of this code is 63. This code is used for single error correction. The code is capable of detecting all the error patterns of double and odd number errors. The outer code is also a distance-4 shortened Hamming code with generator polynomial,

$$\begin{aligned} \bar{g}(X) &= (X+1)(X^{15}+X^{14}+X^{13}+X^{12}+X^4+X^3+X^2+X+1) \\ &= X^{16}+X^{12}+X^5+1 , \end{aligned}$$

where $X^{15}+X^{14}+X^{13}+X^{12}+X^4+X^3+X^2+X+1$ is a primitive polynomial of degree 15. This code is the X.25 standard for packet-switched data networks. The natural length of this code is $2^{15}-1 = 32,767$. But maximum length n_b being considered is 2,048 bits. The 16 parity bits of this code is used for error detection only.

To evaluate $P_{ud}^{(b)}(\epsilon)$, we need to know the weight configurations and orders of error patterns for C_b . The weight configurations and orders of errors patterns of weights 4, 6 and 8 are listed in Table 1. The order of an error pattern \bar{e} , $O_\epsilon(\bar{e})$, is at least

$$w(\bar{e}) - \lfloor w(\bar{e})/4 \rfloor , \quad (18)$$

which occurs for the weight configuration

$$(4, 4, \dots, 4, w(\bar{e}) - 4\lfloor w(\bar{e})/4 \rfloor + 4) ,$$

where $\lfloor x \rfloor$ denotes the integer no greater than x .

Suppose that $n \geq 7$ and

$$\epsilon \leq 1/2n . \quad (19)$$

Then $(1-\epsilon)^n \geq 1/2$ and $(1-\epsilon)/\epsilon \geq 13$. Note that

$$Q_1(w, \epsilon)^{1/w} = \frac{\epsilon}{1-\epsilon} \left[\frac{w(1-\epsilon)^{n+1}}{\epsilon} \right]^{1/w} \left[1 + \frac{\epsilon}{w(1-\epsilon)} + \frac{n-w}{w} \left(\frac{\epsilon}{1-\epsilon} \right)^2 \right]^{1/w} , \quad (20)$$

which decreases monotonically as w increases for $4 \leq w \leq n$. Hence

$$Q_1(w', \epsilon)^{1/w'} \leq Q_1(w, \epsilon)^{1/w}, \quad (21)$$

for $4 \leq w \leq w' \leq n$. It is easy to check that

$$Q_1(4, \epsilon) \leq Q_1(4, \epsilon)^{1/2} \leq Q_1(4, \epsilon)^{1/3} \leq Q_1(6, \epsilon)^{1/6}. \quad (22)$$

It follows from (14), (21) and (22) that

$$P_b(\bar{e}, \epsilon) = \begin{cases} Q_1(4, \epsilon)^{w(\bar{e})/4}, & \text{if } w(\bar{e}) \text{ is a multiple of } 4, \\ Q_1(4, \epsilon)^{\lfloor w(\bar{e})/4 \rfloor - 1} Q_1(6, \epsilon), & \text{otherwise.} \end{cases} \quad (23)$$

Let

$$\bar{\epsilon} \triangleq Q_1(4, \epsilon)^{1/4}. \quad (24)$$

Then, it follows from (20) that

$$\bar{\epsilon} \leq 1.5 \epsilon^{3/4}. \quad (26)$$

Let $\{A_i^{(b)}\}$ be the weight distribution of the outer code C_b . Suppose that A_4^1 and A_6^1 of the one-segment subcode of C_b are known besides $\{A_i^{(b)}\}$. Then it follows from (14), (21) to (24) and Table 1 that

$$\begin{aligned} P_{ud}^{(b)}(\epsilon) &\leq m A_4^1 \bar{\epsilon}^{-4} + (A_4^{(b)})^{-m} A_4^1 \bar{\epsilon}^{-8} + m A_6^1 Q_1(6, \epsilon) \\ &\quad + (A_6^{(b)})^{-m} A_6^1 \bar{\epsilon}^{-8} + \sum_{i=2}^{\lfloor n_b/4 \rfloor} A_{4i}^{(b)} \bar{\epsilon}^{-4i} \\ &\quad + \sum_{i=2}^{\lfloor (n_b-2)/4 \rfloor} A_{4i+2}^{(b)} \bar{\epsilon}^{-4i-4} Q_1(6, \epsilon). \end{aligned} \quad (27)$$

where m is the number of segments per block (see Figure 2) and $2 \leq m \leq 52$.

Let $A_i^{1,j}$ be the number of codewords of weight i in two-segment $(1, j)$ subcode of C_b for $1 < j \leq m$. If A_4^1 , A_6^1 , A_8^1 and $A_i^{1,j}$ with $1 < j \leq m$ and $4 \leq i \leq 8$ are known, then $P_{ud}^{(b)}(\epsilon)$ can be bounded as follows:

$$\begin{aligned}
 P_{ud}^{(b)}(\epsilon) \leq & m A_4^1 \epsilon^{-4} + \sum_{j=2}^m (m-j)(A_4^{1,j} - 2A_4^1) \epsilon^{-8} \\
 & + [A_4^{(b)} - m A_4^1 - \sum_{j=2}^m (m-j)(A_4^{1,j} - 2A_4^1)] \epsilon^{-12} \\
 & + m A_6^1 Q_1(6, \epsilon) + \sum_{j=2}^m (m-j)(A_6^{1,j} - 2A_6^1) \epsilon^{-8} \\
 & + [A_6^{(b)} - m A_6^1 - \sum_{j=2}^m (m-j)(A_6^{1,j} - 2A_6^1)] \epsilon^{-12} \\
 & + m A_8^1 Q_1(8, \epsilon) + \sum_{j=2}^m (m-j)(A_8^{1,j} - 2A_8^1) \epsilon^{-8} \\
 & + [A_8^{(b)} - m A_8^1 - \sum_{j=2}^m (m-j)(A_8^{1,j} - 2A_8^1)] \epsilon^{-12} \\
 & + \sum_{i=2}^{\lfloor (n_b-2)/4 \rfloor} A_{4i+2}^{(b)} \epsilon^{-4i-4} Q_1(6, \epsilon) + \sum_{i=3}^{\lfloor n_b/4 \rfloor} A_{4i}^{(b)} \epsilon^{-4i}. \quad (28)
 \end{aligned}$$

If $A_{i_1, i_2}^{1, j}$ for $2 \leq j \leq m$ and $4 \leq i_1 + i_2 \leq 8$ are also known, a better bound on P_{ud} can be obtained,

$$\begin{aligned}
 P_{ud}^{(b)}(\epsilon) \leq & a_4 \epsilon^{-4} + (a_{1,3} + a_{3,1} + a_{2,2}) \epsilon^{-8} + \bar{A}_4^{(b)} \epsilon^{-12} \\
 & + a_6 Q_1(6, \epsilon) + (a_{2,4} + a_{4,2} + a_{3,3}) \epsilon^{-8} \\
 & + (a_{1,5} + a_{5,1}) \epsilon^{-4} Q_1(6, \epsilon) + \bar{A}_6^{(b)} \epsilon^{-12} \\
 & + a_8 Q_1(8, \epsilon) + (a_{1,7} + a_{7,1}) \epsilon^{-4} Q_1(8, \epsilon) \\
 & + (a_{2,6} + a_{6,2} + a_{3,5} + a_{5,3}) \epsilon^{-4} Q_1(6, \epsilon) + a_{4,4} \epsilon^{-8} \\
 & + \bar{A}_8^{(b)} \epsilon^{-12} \sum_{i=2}^{\lfloor (n_b-2)/4 \rfloor} A_{4i+2}^{(b)} \epsilon^{-4i-4} Q_1(6, \epsilon) + \sum_{i=3}^{\lfloor n_b/4 \rfloor} A_{4i}^{(b)} \epsilon^{-4i}, \quad (29)
 \end{aligned}$$

where

$$\begin{aligned}
 a_i &= m A_i^1, \\
 a_{i_1, i_2} &= \sum_{j=2}^m (m-j) A_{i_1, i_2}^{1, j}, \\
 \bar{A}_i^{(b)} &= A_i^{(b)} - a_i - \sum_{i_1 + i_2 = i} a_{i_1, i_2}. \quad (30)
 \end{aligned}$$

The weights A_i^1 , $A_i^{1,j}$ and $A_{i_1, i_2}^{1,j}$ can be computed from those of the dual code of C_b by the MacWilliams' identities [3].

If finer weight structure of C_f and C_b is known, further improvement on bounding $P_{ud}^{(b)}(\epsilon)$ can be made. Let $A_{i,j}^{(f,b)}$ denote the number of codewords \bar{v} in C_f such that $w^{(1)}(\bar{v}) = i$, $w^{(2)}(\bar{v}) = j$ and the vector consisting of the first k bits of \bar{v} and $n_b - k$ zeros is a codeword in one-segment subcode of C_b . Better bounds on $P_{ud}^{(b)}(\epsilon)$ can be obtained by replacing $m A_4^1 \epsilon^4$, $m A_6^1 Q_1(6, \epsilon)$ and $m A_8^1 Q_1(8, \epsilon)$ by $m \sum_{j=0}^{n-k} A_{4,j}^{(f,b)} Q_1(4+j, \epsilon)$, $m \sum_{j=0}^{n-k} A_{6,j}^{(f,b)} Q_1(6+j, \epsilon)$ and $m \sum_{j=0}^{n-k} A_{8,j}^{(f,b)} Q_1(8+j, \epsilon)$ respectively in (27), (28) and (29).

For moderate code length n , it may be feasible to compute $A_{i,j}^{(f,b)}$. Evaluation based on (27) for $\epsilon = 10^{-5}$ is given in Table 2. Evaluation of $P_{ud}^{(b)}(\epsilon)$ based on (28) or (29) will be made in the next report.

REFERENCES

1. S. Lin and D. J. Costello, Jr., Error Control Coding: Fundamentals and Applications, Prentice-Hall, New Jersey, 1983.
2. F.J. MacWilliams and N.J.A. Sloane, Theory of Error-Correcting Codes, North Holland, Amsterdam, 1977.
3. J. MacWilliams, "A Theorem on the Distribution of Weights in a Systematic Code," Bell System Technical Journal, Vol. 42, pp. 79-94, 1963.

Table 1

weight	weight configuration	$G_{\epsilon}(e)$
4	4	3 "bad"
	1, 3	6 "good"
	2, 2	6 "good"
	1, 1, 2	9 "good"
	1, 1, 1, 1	12 "good"
6	6	5 "bad"
	1, 5	8 "good"
	2, 4	6
	3, 3	6
	1, 1, 4	9 "good"
	1, 2, 3	9 "good"
	2, 2, 2	9 "good"
	1, 1, 1, 3	12 "good"
	1, 1, 2, 2	12 "good"
8	8	7 "bad"
	1, 7	10 "good"
	2, 6	8
	3, 5	8
	4, 4	6 "bad"
	1, 1, 6	11 "good"
	1, 2, 5	11 "good"
	1, 3, 4	9 "good"
	2, 2, 4	9 "good"
	2, 3, 3	9 "good"
	others	≥ 12 "good"

Table 2

ORIGINAL PAGE IS
OF POOR QUALITY

$$\epsilon = 10^{-5}$$

n_b	$P_{ud}^{(b)}(\epsilon)$	n_b	$P_{ud}^{(b)}(\epsilon)$
160	$.6809 \times 10^{-11}$	1120	$.9067 \times 10^{-8}$
192	$.1411 \times 10^{-10}$	1152	$.1907 \times 10^{-7}$
224	$.2086 \times 10^{-10}$	1184	$.1115 \times 10^{-7}$
256	$.3013 \times 10^{-10}$	1216	$.1231 \times 10^{-7}$
288	$.4802 \times 10^{-10}$	1248	$.1356 \times 10^{-7}$
320	$.7277 \times 10^{-10}$	1280	$.1489 \times 10^{-7}$
352	$.1058 \times 10^{-9}$	1312	$.1632 \times 10^{-7}$
384	$.1489 \times 10^{-9}$	1344	$.1784 \times 10^{-7}$
416	$.2038 \times 10^{-9}$	1376	$.1945 \times 10^{-7}$
448	$.2722 \times 10^{-9}$	1408	$.2117 \times 10^{-7}$
480	$.3561 \times 10^{-9}$	1440	$.2299 \times 10^{-7}$
512	$.4576 \times 10^{-9}$	1472	$.24 \times 10^{-7}$
544	$.5789 \times 10^{-9}$	1504	$.2696 \times 10^{-7}$
576	$.7222 \times 10^{-9}$	1536	$.2912 \times 10^{-7}$
608	$.8899 \times 10^{-9}$	1568	$.3139 \times 10^{-7}$
640	$.1084 \times 10^{-8}$	1600	$.3379 \times 10^{-7}$
672	$.1307 \times 10^{-8}$	1632	$.3631 \times 10^{-7}$
704	$.1563 \times 10^{-8}$	1664	$.3896 \times 10^{-7}$
736	$.1853 \times 10^{-8}$	1696	$.4174 \times 10^{-7}$
768	$.2180 \times 10^{-8}$	1728	$.4467 \times 10^{-7}$
800	$.2547 \times 10^{-8}$	1760	$.4773 \times 10^{-7}$
832	$.2957 \times 10^{-8}$	1792	$.5093 \times 10^{-7}$
864	$.3413 \times 10^{-8}$	1824	$.5428 \times 10^{-7}$
896	$.3917 \times 10^{-8}$	1856	$.5778 \times 10^{-7}$
928	$.4473 \times 10^{-8}$	1888	$.6144 \times 10^{-7}$
960	$.5084 \times 10^{-8}$	1920	$.6525 \times 10^{-7}$
992	$.5753 \times 10^{-8}$	1952	$.6923 \times 10^{-7}$
1024	$.6482 \times 10^{-8}$	1984	$.7337 \times 10^{-7}$
1056	$.7275 \times 10^{-8}$	2016	$.7768 \times 10^{-7}$
1088	$.8136 \times 10^{-8}$	2048	$.8216 \times 10^{-7}$

ORIGINAL PAGE IS
OF POOR QUALITY

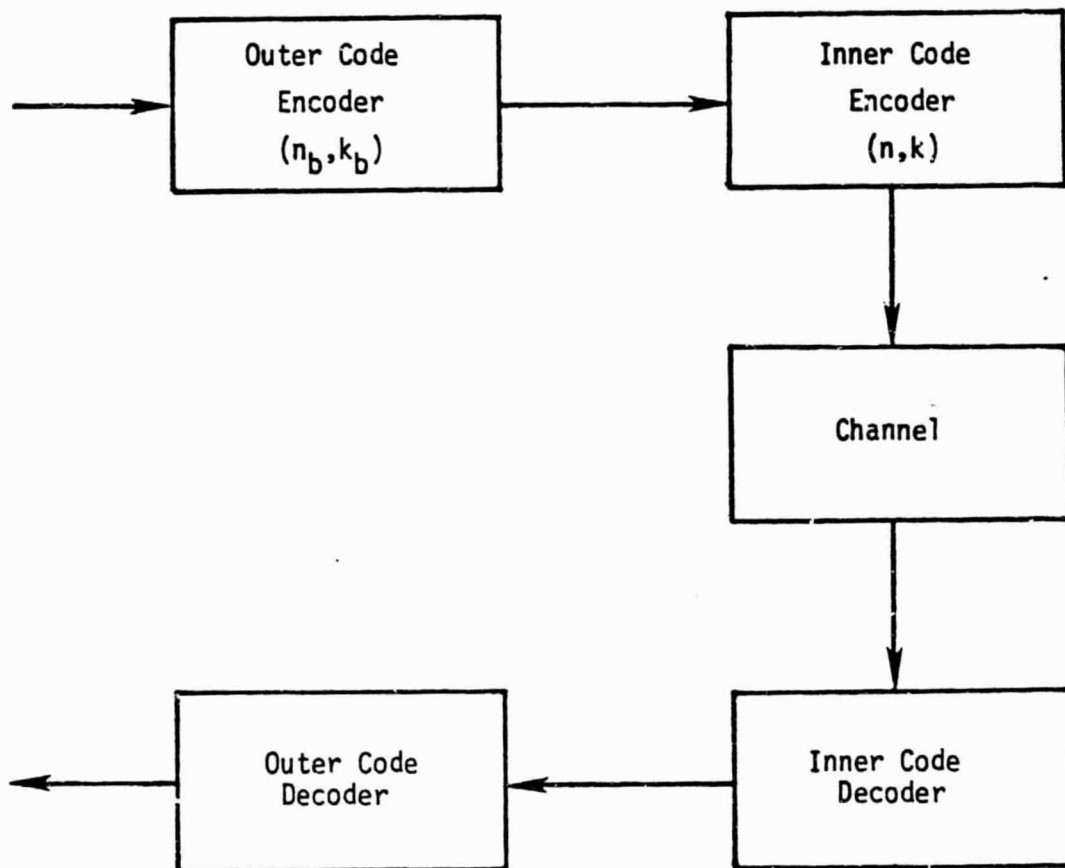

Figure 1 A concatenated coding system

ORIGINAL PAGE IS
OF POOR QUALITY

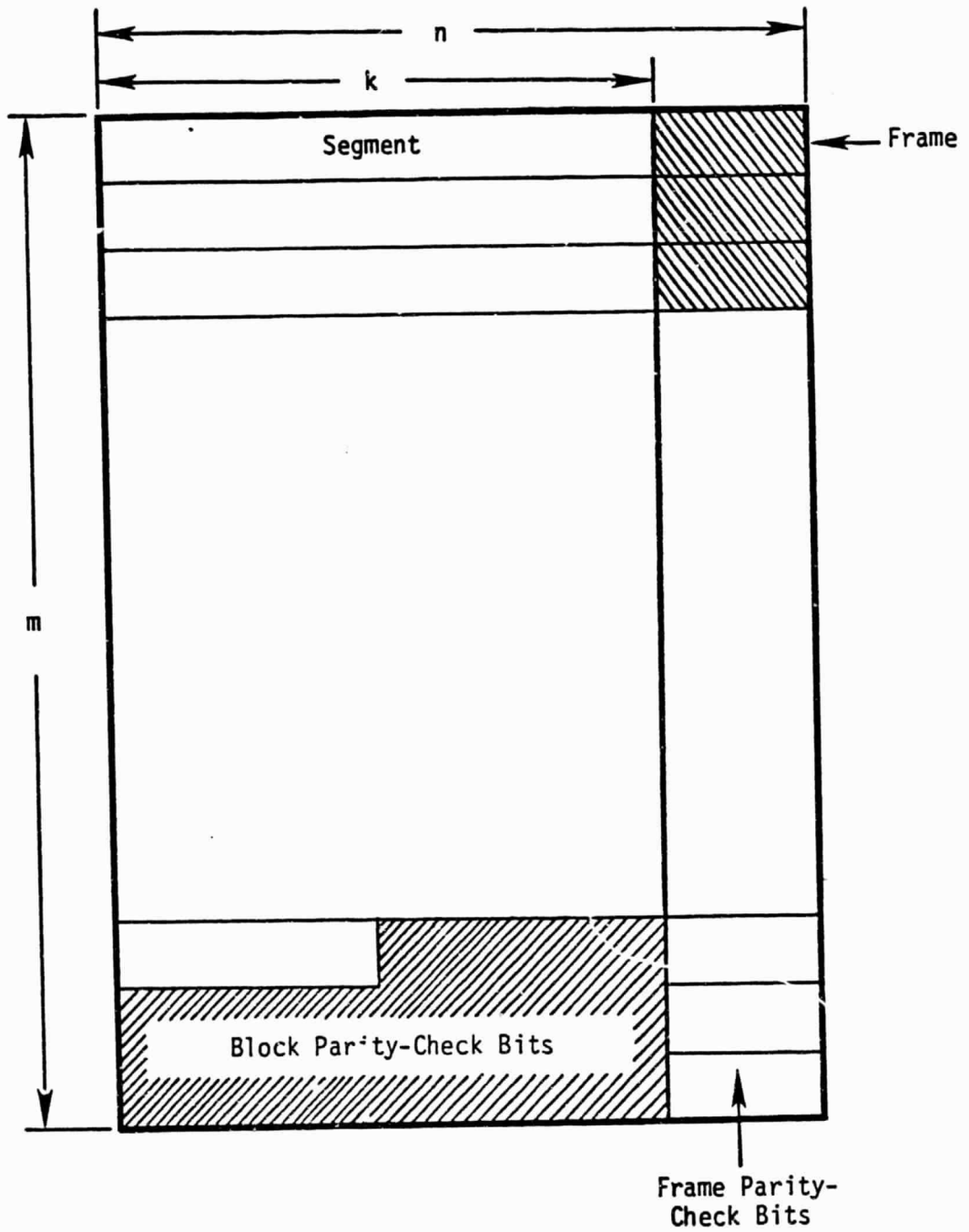

Figure 2 Block format