

**NASA
Technical
Paper
2238**

January 1984

Development of an Instrument
for Real-Time Computation of
Indicated Mean Effective Pressure

William J. Rice

TP
2238
c.1



TECH LIBRARY KAFB, NM

LOAN COPY: RETURN TO
AFWL TECHNICAL LIBRARY
KIRTLAND AFB, N.M. 87117



**NASA
Technical
Paper
2238**

1984

Development of an Instrument
for Real-Time Computation of
Indicated Mean Effective Pressure

William J. Rice

*Lewis Research Center
Cleveland, Ohio*



National Aeronautics
and Space Administration

**Scientific and Technical
Information Office**

1984

Summary

A new instrument capable of computing in real time the per-cycle indicated mean effective pressure (IMEP) of internal combustion engines and compressors has been designed and tested. The values of IMEP obtained with the new instrument were found to be in excellent agreement with values obtained by previous postrun data-reduction techniques.

Introduction

One of the most significant indicators of the performance of internal combustion engines as well as compressors is the indicated mean effective pressure (IMEP). Although the word "mean" in this parameter suggests that IMEP is a measurement of the average cylinder pressure, IMEP is actually a computation of the work delivered at the piston face during a complete engine cycle. In all of the discussion to follow, IMEP is defined as the total cycle integral of $P dV$.

If the cylinder pressure P is plotted against the cylinder volume V , the resultant curve is known as the PV diagram or engine indicator card. A typical PV diagram for a four-cycle internal combustion engine is illustrated in figure 1. The lower portion of the curve (area of negative work, ANW) represents the pumping losses in the engine. The upper portion (area of positive work, APW) represents the expansion work done by the engine. The net work done by the engine is then the difference $APW - ANW$. IMEP is this net work divided by the displacement volume V_D .

Early methods of measuring IMEP involved recording directly on paper a PV diagram by using various mechanical linkages that connected the recording pen to the piston-position and pressure-measuring devices. The resulting PV diagram was then cut out and weighed to measure the enclosed area. Later developments included the use of mechanical planimeters for measuring the area, the development of electronic volume transducers, the use of oscilloscopes to display the PV diagram in real time, and the use of cameras to record the PV diagrams for analysis. More recent efforts have been directed to the use of high-speed recorders and computerized analyses.

Despite the relative sophistication of these recent techniques, all of them involve postrun data reduction. Present research at the Lewis Research Center in the areas of engine efficiency, fuel economy, pollutant reduction, and overall performance analysis has necessitated the development of an instrument for measuring IMEP in real time. The design, development, and performance of such an instrument is the subject of this report. This instrument is part of the NASA-designed modular engine instrumentation system (MEIS, ref. 1).

It is worthwhile to note here that there are several definitions of IMEP. One definition is the one used above, that is, the 720° integral of $P dV$. This integral is sometimes referred to as the cyclic integral and computes IMEP as the "net" work done in a combustion cycle by subtracting the lower, or "pumping," loop work from the upper, or "compression and expansion," loop work. The other definition of IMEP is the 360° integral of $P dV$ done for the compression and expansion strokes only, that is, the upper loop.

The equations and discussion in this report relate to the cyclic integral definition of IMEP. However, a simple modification to the basic circuit diagram is shown that will allow the IMEP instrument to compute on either the upper loop, the lower loop, or both.

From a thermodynamic analysis the work performed on or by a chemical system during a volumetric change in state is

$$W = \int_{V_i}^{V_f} P dV$$

where

W	work
V_f	final volume
V_i	initial volume
P	cylinder pressure

When this calculation is performed for a complete cycle, the net work or indicated work W_I becomes

$$W_I = \oint_V P dV$$

When this indicated work is normalized to a per-unit volume work by dividing by the total cylinder displacement volume V_D , the result is in units of pressure and is defined as the IMEP.

$$\text{IMEP} = \frac{1}{V_D} \oint_V P dV$$

The indicated power (IP) of an engine can then be determined by the equation

$$\text{IP} = \frac{\text{IMEP} \times A \times L \times N}{k}$$

where

A	piston surface area
L	piston stroke

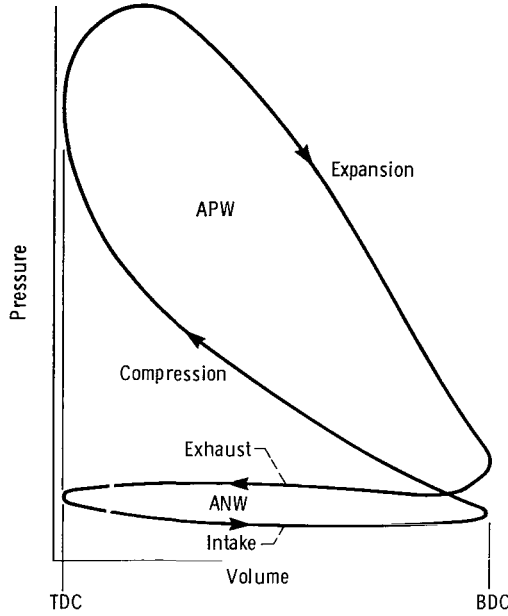

Figure 1. – Typical pressure-volume diagram for four-cycle engine.
 $IMEP = (APW - ANW) / V_D$

N number of engine cycles per minute

and k is a constant that depends on the system of units used. The brake power (BP) of the engine can be determined by measuring the torque and speed:

$$BP = \frac{T \times RPM \times 2\pi}{k}$$

where

T engine torque

RPM engine speed

2π conversion factor for revolutions to radians

Also from a thermodynamic analysis it can be shown that the IP is the sum of the BP and the frictional power (FP). Thus, by measuring IMEP, torque, and speed, the FP and the engine efficiency can be determined.

$$FP = IP - BP$$

$$\eta_M = \frac{BP}{IP}$$

where η_M is mechanical efficiency. From the preceding discussion, it is apparent that IMEP is an important measure of the performance of an engine or a compressor.

System Equations

The indicated mean effective pressure (IMEP) has been defined as

$$IMEP = \frac{1}{V_D} \oint_V P dV$$

where

P cylinder pressure

V cylinder volume

V_D total cylinder displacement volume

One method used to calculate IMEP is to compute this integral in the time domain as follows:

$$\frac{1}{V_D} P dV = \frac{1}{V_D} \int_{t=0}^{t=4\pi/w} P \left(\frac{dV}{dt} \right) dt$$

where

t time

w engine angular velocity

This method has the disadvantage that it requires the real-time differentiation of V to get dV/dt . Real-time differentiation is quite difficult to perform since the circuits needed are extremely sensitive to electrical noise. This noise can be partially eliminated by the use of band-pass differentiators, but the phase error introduced limits the accuracy of the computation.

This new instrument calculates IMEP by evaluating the $P dV$ integral in the θ , or engine crankangle, domain by making a change in variables as follows:

$$\frac{1}{V_D} \oint P dV = \frac{1}{V_D} \int_{\theta=0}^{4\pi} P \left(\frac{dV}{d\theta} \right) d\theta$$

where θ is engine crankangle. In this form the function $dV/d\theta$ can be determined algebraically from the engine geometry and does not need to be computed in real time. The function, once computed, can then be stored in the instrument. A typical engine geometry is shown in figure 2. The piston position S as a function of crankangle θ can be determined by inspection to be

$$S = R + r(1 + \cos \theta) - (R^2 - r^2 \sin^2 \theta)^{1/2}$$

where

S piston position

R connecting rod length

r one-half stroke

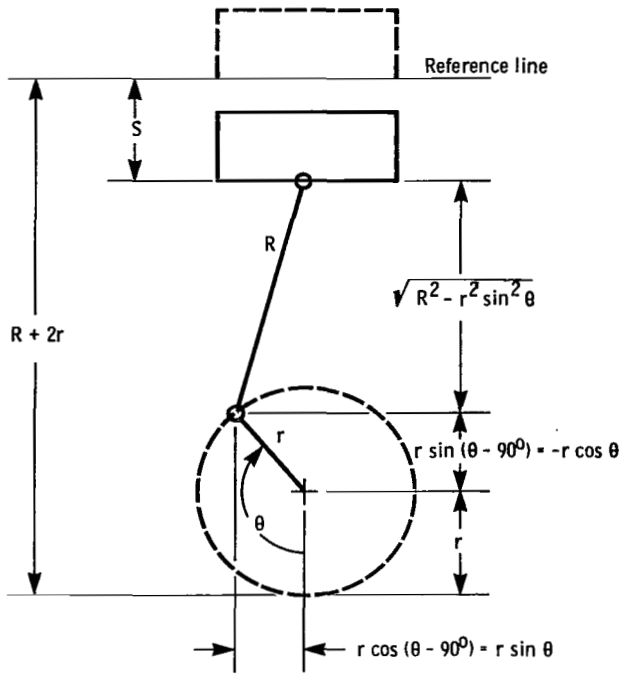

Figure 2. - Typical engine geometry.

$$S = R + 2r - r + r \cos \theta - \sqrt{R^2 - r^2 \sin^2 \theta}$$

$$= R + r(1 + \cos \theta) - \sqrt{R^2 - r^2 \sin^2 \theta}$$

where S is piston position, R is connecting rod length, r is one-half stroke, and θ is crankangle.

Multiplying the right side of this equation by the piston area gives the volume equation

$$V = A [R + r(1 + \cos \theta) - (R^2 - r^2 \sin^2 \theta)^{1/2}]$$

where A is piston area. Differentiating V with respect to θ yields

$$\frac{dV}{d\theta} = A \left[-r \sin \theta + \frac{r^2 \sin \theta \cos \theta}{(R^2 - r^2 \sin^2 \theta)^{1/2}} \right]$$

This equation is evaluated for discrete values of θ every 0.0123 radian (0.7°) starting at bottom dead center (BDC) and ending at top dead center (TDC). The values of $dV/d\theta$ are normalized by assigning the value 255 to the maximum $dV/d\theta$. A plot of $dV/d\theta$ versus θ for a 1975 5.7-liter Chevrolet engine is shown in figure 3.

The IMEP is computed according to the approximation

$$\text{IMEP} = \oint_V \frac{P dV}{V_D} \approx K \sum_{m=0}^{1023} P \left(\frac{dV}{d\theta} \right) \Big|_{m\Delta\theta}$$

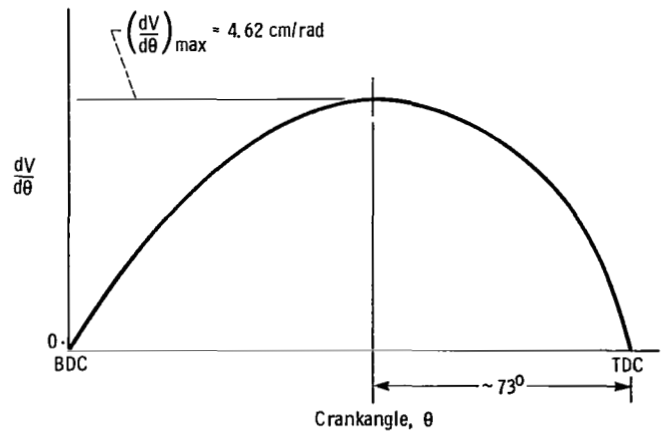

Figure 3. - Diagram of $dV/d\theta$ versus θ for a typical engine (1975 Chevrolet).

where

K constant

$\Delta\theta$ $2\pi/1024$ rad

The determination of the scaling constant K is shown later in this report. Figure 4 shows a PV diagram with a typical computational $(dV/d\theta)\Delta\theta$ slice. The computational slice contains the four terms shown below:

$$+ P_1 \Delta V \text{ from the intake stroke} = A_1$$

$$- P_3 \Delta V \text{ from the compression stroke} = -(A_3 + A_2 + A_1)$$

$$+ P_4 \Delta V \text{ from the power stroke} = +(A_4 + A_3 + A_2 + A_1)$$

$$- P_2 \Delta V \text{ from the exhaust stroke} = -(A_2 + A_1)$$

$$\text{Slice sum} = A_4 - A_2$$

The terms for the compression and exhaust strokes are negative because the volume is decreasing and hence V is a negative quantity. It can be seen that when the computation is performed for all ΔV slices, the total sum is the area $APW - ANW$ of figure 1.

The ΔV slices vary in width since the computation is performed at constant ΔV increments. Thus there are more and thinner slices near TDC and BDC. The widest slice and hence the lowest computational resolution is at the point of maximum piston velocity. For typical automotive and light aircraft engines this point is approximately 73° before and after TDC. A lower bound on the computational resolution can be determined by the following equation:

$$\text{CR}_{\min} = \frac{V_D}{(dV/d\theta)_{\max} \Delta\theta}$$

where

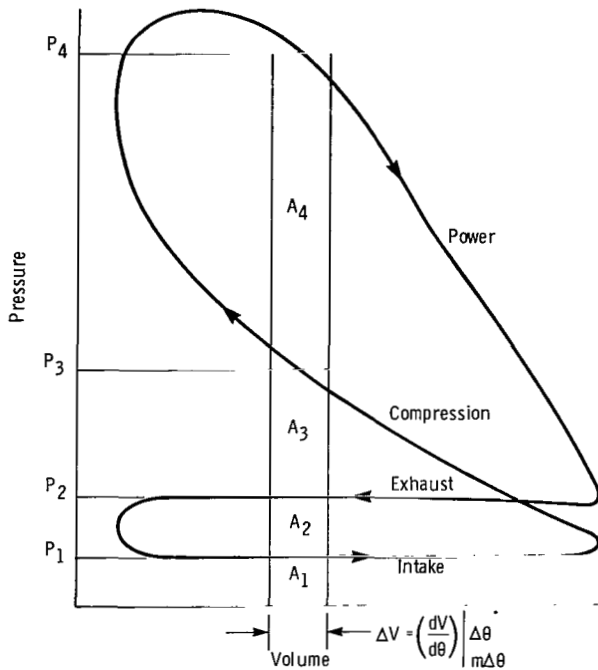

Figure 4. — Computational slice of a pressure-volume diagram.

V_D displacement volume
 CR_{\min} minimum resolution in computations per engine stroke if dV were constant and equal to dV_{\max}
 For the Chevrolet engine this lower bound is 155 computations per stroke.

Design Goals

The IMEP instrument design was oriented toward the following goals:

- (1) Calculation of IMEP in real time for every engine cycle by using cylinder pressure and crankangle as the only two input parameters
- (2) Operation to engine speeds of 6000 rpm
- (3) Accuracy of 1 to 2 percent of full scale
- (4) Repeatability of 1/2 to 1 percent of full scale
- (5) Capability of calculating the IMEP for any cylinder of multicylinder engines
- (6) Accurate calibration with a minimum of complexity
- (7) Easy adaption to engines of different geometry
- (8) Use of only readily available components to provide a cost-effective design

Instrument Block Diagram

A block diagram of the IMEP instrument is shown in figure 5. Engine crankangle data are generated externally

to this instrument by an absolute-position optical-shaft-angle encoder (ref. 1). These crankangle data are input to the memory address decoder (MAD). The MAD generates the actual memory address, the sign of the computation, and the computation start and stop signals. The contents of the read-only memory (ROM) are the values of $dV/d\theta$ for 256 values of θ starting at BDC and ending at TDC. Because of the inherent symmetry in engines exhibiting no eccentricity (i.e., the axis of piston motion passes through the rotation axis of the engine crank), the values of $dV/d\theta$ from TDC to BDC are the negative of those from BDC to TDC for equal angles before and after TDC. Thus it is necessary only to store the absolute value of $dV/d\theta$ in the memory. The sign of the computation can be determined by knowing whether the crank is before or after the TDC position. This effectively increases the resolution by a factor of 2 for a fixed memory word size. It also allows the multiplying digital-to-analog converter (MDAC) and the analog-to-digital converter (ADC) to be unipolar devices, thus eliminating any errors due to zero offsets and zero drifts with time or temperature.

In multicylinder engines there is a fixed geometric relationship between the instantaneous volumes of the various cylinders that in polar coordinates is simply a phase difference. Thus, by properly decoding the crankangle position data the same $dV/d\theta$ ROM can be used to compute IMEP for any of the engine cylinders. In this instrument the IMEP computation starts and stops at TDC of the intake stroke for the cylinder of interest.

The contents of the ROM are applied as the digital input to the MDAC. The pressure signal P is applied as the analog input to the MDAC. The pressure signal is conditioned within the instrument such that it is always in the range $0 \leq P \leq 10$ V. This conditioning is necessary because a piezoelectric pressure transducer is normally used to measure the cylinder pressure. This type of transducer produces an electrical output that has no fixed dc reference level associated with it and thus could assume negative values, which would force the use of a bipolar MDAC and ADC in the instrument.

The output of the MDAC is an analog signal equal to the product $P(dV/d\theta)$. This signal is then digitized by the ADC. Because this $P(dV/d\theta)$ product is digitized instead of the pressure signal, the need for a fast digital multiplier is eliminated.

The digital output of the ADC is the 10-bit binary number equivalent of $P(dV/d\theta)$ for a certain slice. This binary number and the sign information from the MAD are used by the code converter to generate a two's-complement coded signal for compatibility with the accumulator. The accumulator continuously sums the $P(dV/d\theta)$ terms for a complete combustion cycle. The instantaneous output of the accumulator is equal to the running summation

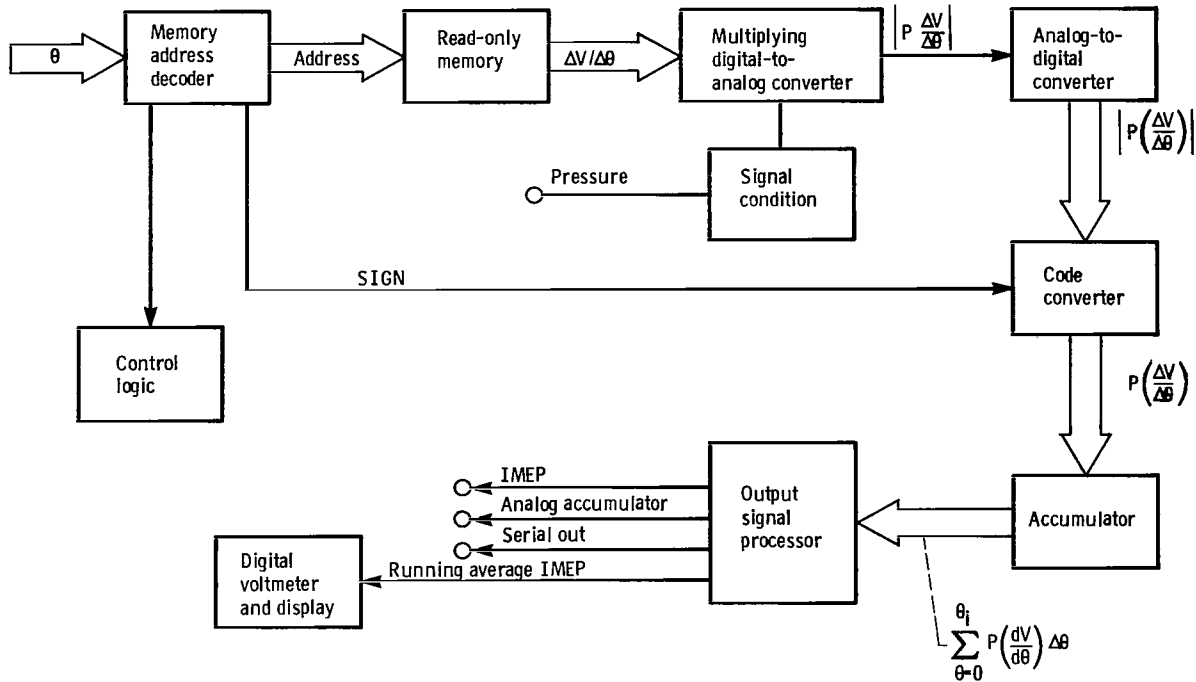

Figure 5. – Block diagram of IMEP instrument.

$$K \sum_{\theta=0}^{\theta=\theta_i} P \left(\frac{dV}{d\theta} \right) \Delta\theta$$

At $\theta = 720^\circ$ the output of the accumulator is equal to the IMEP for that combustion cycle. This final value is stored in the output signal processor (OSP). The OSP produces four outputs:

- (1) An analog signal proportional to the IMEP for the cycle just completed
- (2) An analog signal proportional to the running average IMEP with a time constant of 50 combustion cycles
- (3) An analog signal proportional to the instantaneous value of the accumulator
- (4) A serial digital output proportional to the IMEP for the combustion cycle just completed. This output is used by the statistical signal processor (ref. 1).

A digital voltmeter (DVM) and a numerical display are also incorporated in the instrument for local display of the running average IMEP.

The signals during the IMEP computation are shown in figure 6 for one 720° combustion cycle starting at TDC of the intake stroke (0°). Figure 6(a) is the absolute value, as an analog signal, of $\Delta V/\Delta\theta$. The actual value of $\Delta V/\Delta\theta$ is negative during the second and fourth quadrants of the trace (i.e., the compression and exhaust cycles). The absolute value of $P \Delta V/\Delta\theta$ is shown in

figure 6(b). Again, the actual value would be negative during the second and fourth quadrants.

Figure 6(c) is the running summation of the $P \Delta V/\Delta\theta$ products. This trace, which indicates positive work produced by the engine during the intake stroke, results from the computation being performed with an absolute pressure transducer measuring the cylinder pressure. The effects of crankcase pressure acting on the bottom surface of the piston are not compensated for in this instrument. However, if it is assumed that the crankcase pressure remains constant during the combustion cycle, the effect would be a subtraction of a constant value from the cylinder pressure. Since the closed-line integration of a constant is zero, a constant crankcase pressure does not affect the final value of the IMEP computation. This can be verified by inspecting the following equation:

$$\oint_V (P_{cyl} - P_{cc}) dV = \oint_V P_{cyl} dV - \oint_V P_{cc} dV$$

where

- P_{cyl} cylinder pressure
- P_{cc} crankcase pressure

However, the inclusion of the crankcase pressure would cause the traces in figures 6(b) and 6(c) to indicate negative work during the intake stroke.

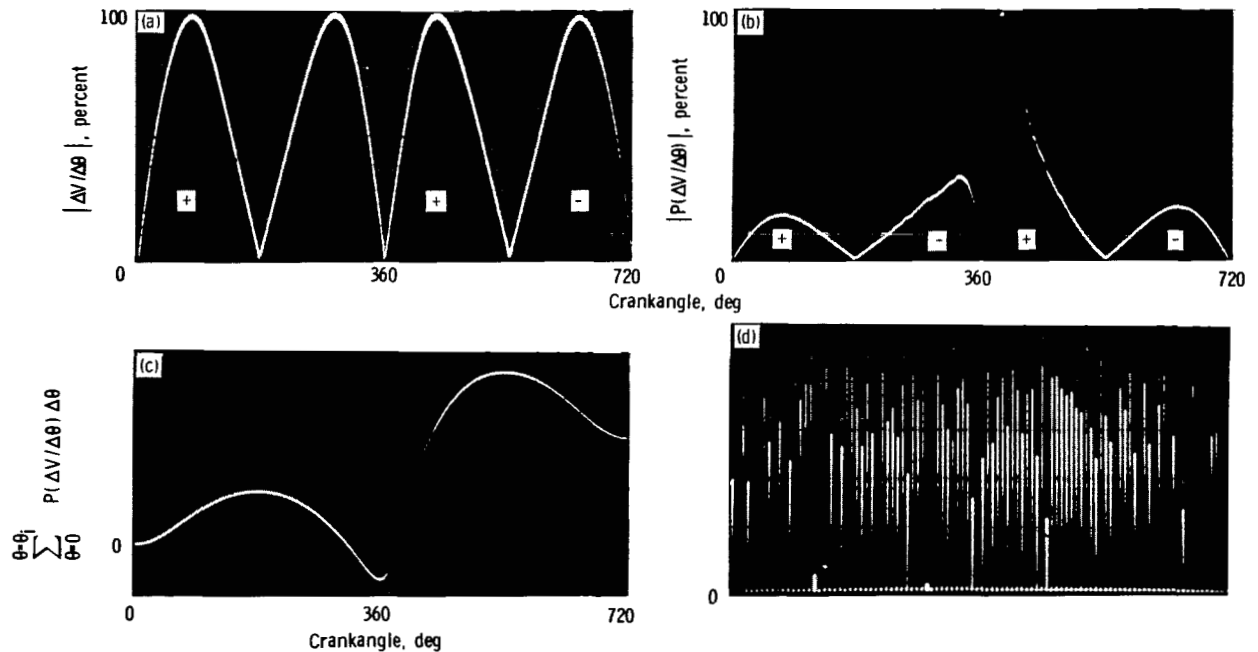

(a) Absolute value of $\Delta V/\Delta\theta$ versus crankangle.
 (b) Absolute value of $P(\Delta V/\Delta\theta)$ versus crankangle.
 (c) Running summation of $P(\Delta V/\Delta\theta)$ versus crankangle. 140 kPa/division.
 (d) Bargraph of 100 consecutive IMEP values. 70 kPa/division.

Figure 6. — Signals during IMEP computation.

Figure 6(d) is a bargraph of 100 values of IMEP computed for 100 consecutive combustion cycles. This bargraph is produced by the statistical signal processor (ref. 1) using the serial digital output from the IMEP instrument. The amplitude of each bar represents the IMEP for an individual combustion cycle. These data were taken near the lean misfire limit of the engine and show considerable variation in IMEP. A similar bargraph is shown in figure 7 for a "smoothly idling" engine. The bars extending below the base line indicate negative work for that particular engine cycle. The largest negative bars indicate total engine misfire.

Instrument Calibration

Calibration of the IMEP instrument is based on the definition of IMEP as the total cycle work divided by the swept cylinder volume. It follows from this definition that if a constant pressure equal to the IMEP were applied to the piston surface for only the power stroke of the engine, the same amount of work would be obtained. The calibration procedure then is to apply the electrical equivalent of the full-scale IMEP value as the pressure input signal to the instrument. The running integration signal should reach the full-scale value of IMEP after 180° of crank rotation starting at TDC at the beginning

of the power stroke and ending at BDC. Since the values of $dV/d\theta$ are the same for the intake stroke as for the power stroke, the actual calibration is performed during the intake stroke as a matter of convenience.

With the electrical equivalent of the full-scale IMEP applied, the calibration potentiometer is adjusted until the running integration signal exactly reaches full scale at BDC. The running integration signal is generated in the output signal processor (OSP) by using an output digital-to-analog converter (ODAC) that has the proper accumulator bits applied at the digital input.

Figure 8 shows the digital signal flow path and the full-scale values at various points in the instrument. The values shown in figure 8 are typical for most automotive and light aircraft engines. The full-scale output was

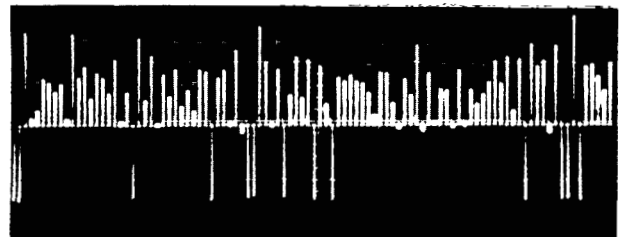

Figure 7. — IMEP bargraph at idle. 70 kPa/division.

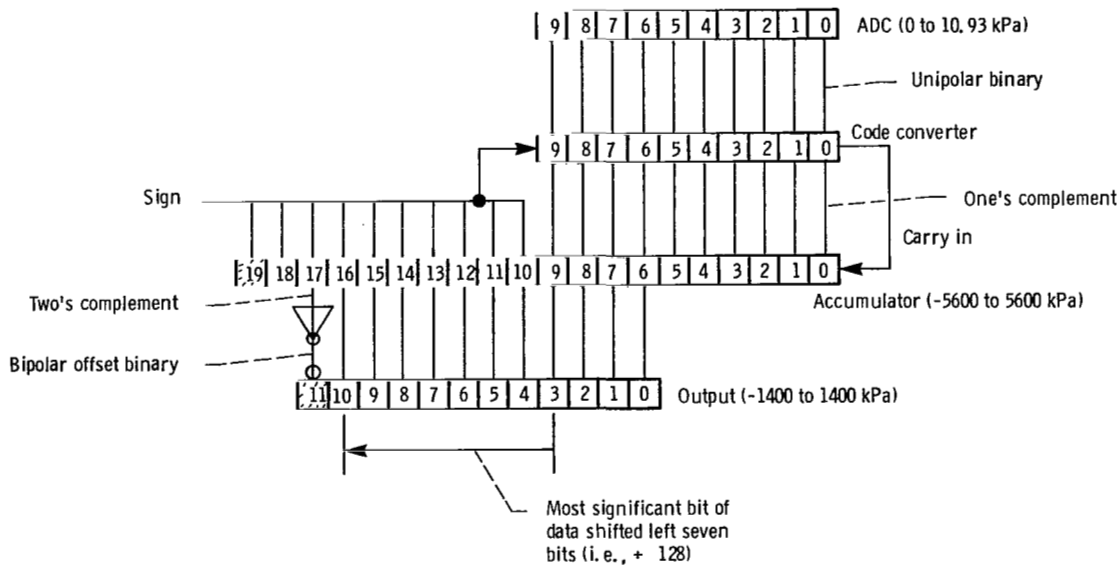

Figure 8. -- Digital signal flow path.

chosen as ± 1400 kPa. Bit 11 of the output is shown shaded to indicate that it is the "SIGN" bit. The output coding is in bipolar offset binary. Negative full scale is represented as all bits equal to logic zero and positive full scale as all bits equal to logic one.

Thus, as the calibration potentiometer is adjusted, the value of the output signal approaches the "all ones" state. The calibration point is achieved as the output signal overflows to the "all zeroes" state, causing the ODAC to go from positive full scale (+ 10 V) to negative full scale (- 10 V). This point is easily discerned and calibration can be very precisely performed.

The digital coding for the accumulator is binary two's complement, which allows for the use of standard binary adder circuits. Because the accumulator extends two bits to the right of the output, the full scale of the accumulator is ± 5600 kPa. This extension is to allow the running summation (fig. 6(c)) to exceed the output full-scale value.

The ADC and the code converter are shifted seven bits to the left of the output signal and thus have a full-scale value of 10.93 kPa. As previously mentioned, the ADC is unipolar. The code converter takes the ADC signal and converts it to one's-complement code for use by the adder circuits. This conversion is done by complementing all of the ADC bits when a negative value is indicated by the SIGN signal. The final conversion to two's complement code is accomplished by adding 1 to the accumulator by forcing the "carry in" signal to a logic one for negative values.

The value of the gain constant K can be determined by analyzing the various gain stages in the instrument along with the pressure transducer range and the IMEP full-scale value. Figure 9 shows the various gain stages in

block diagram form. The gain of the ODAC is 1.0. The gain of the accumulator is $1/128$ by virtue of the output data being shifted seven bits to the left as shown in figure 8. Each shift of one bit position represents an effective gain of $1/2$. A shift of seven bits therefore is a gain of $(1/2)^7$, or $1/128$. Because the ADC is wired such that a full-scale digital value is obtained with a half-scale analog input, its gain is 2. The MDAC has an inherent gain of 1.5 as supplied by the manufacturer. Because 256 separate computations are performed during the power stroke of the engine, an additional gain of 256 must be accounted for in the analysis. The gain of the ROM G depends on the particular engine geometry. This gain also is not constant and depends on the angular crank position. However, the average or effective gain over the entire power stroke can be determined mathematically from the engine geometry. The contents of the ROM are the values of $dV/d\theta$ from $\theta = 0^\circ$ to $\theta = 180^\circ$ (π radians). As depicted by the graph in figure 9, the maximum possible gain of the ROM would be proportional to the product $(dV/d\theta)_{\max}$ times π and is shown as the rectangular area in the graph. The actual gain of the ROM is proportional to the area under the curve. The effective or average gain G is then the ratio of these two areas.

Using values from a Chevrolet 5.7-liter engine:

$$\left. \frac{dV}{d\theta} \right|_{\max} = A \left. \frac{dS}{d\theta} \right|_{\max}$$

$$= 81.1 \text{ cm}^2 \times 4.62 \text{ cm/rad} = 374.78 \text{ cm}^3/\text{rad}$$

$$V(\pi) = A \times \text{Engine stroke} = A \times 8.84 \text{ cm}$$

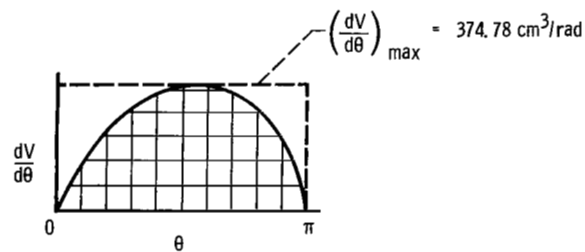
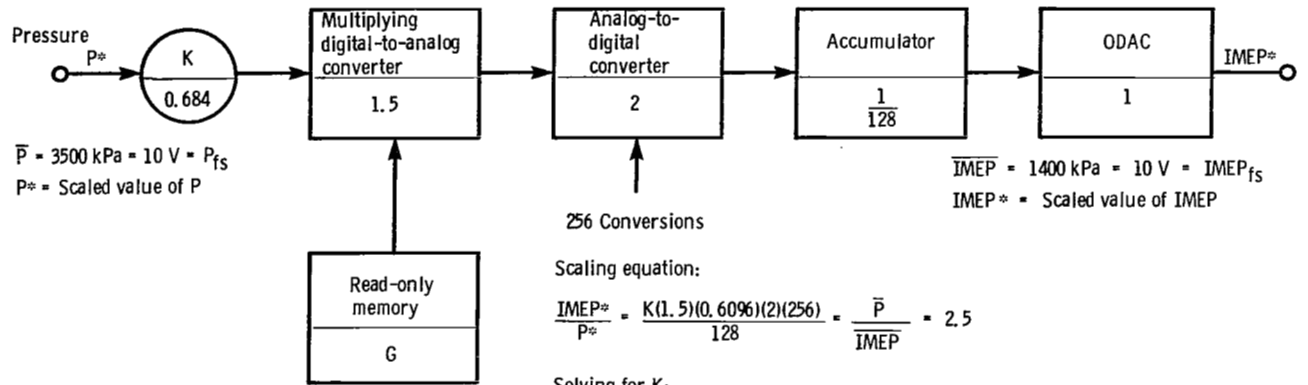

$$\text{Area under curve} = \int_0^{\pi} \left(\frac{dV}{d\theta}\right) d\theta = V(\pi) - V(0)$$

$$= 716.9 \text{ cm}^3$$

$$\text{Total area} = \pi \times \left.\frac{dV}{d\theta}\right|_{max} = \pi (374.78 \text{ cm}^3/\text{rad}) = 1177.4 \text{ cm}^3$$

$$G = \frac{\text{Area under curve}}{\text{Total area}} = 0.6088$$

Figure 9. – Computation scaling.

and

$$V(\pi) - V(0) = A \times S(\pi) - 0 = A \times \text{Engine stroke}$$

$$= 81.1 \text{ cm}^2 \times 8.84 \text{ cm} = 716.3 \text{ cm}^3$$

Then the area ratio, or gain, is

$$G = \frac{716.9 \text{ cm}^3}{374.78 \text{ cm}^3/\text{rad} \times \pi} = 0.6088$$

The total gain of the system is then

$$G_{total} = K(1.5)(2)(256) \left(\frac{1}{128}\right) \left(\frac{IMEP_{fs}}{P_{fs}}\right) (0.6088)$$

where fs is full scale. By definition of IMEP this overall gain must be exactly 1. Therefore setting $G_{total} = 1$ and solving for K yield

$$K = \frac{(128)(3500 \text{ kPa})}{(1.5)(2)(256)(1400 \text{ kPa})(0.6088)}$$

As can be seen from this equation, the gain constant K depends on the ratio of full-scale pressure to full-scale IMEP. A potentiometer is used in the circuitry to establish K , and therefore the range of K is limited to $0 \leq K \leq 1$. This places a restriction on the full-scale value of IMEP.

Letting $K = 1$ in the above equation and solving for the ratio $IMEP_{fs}/P_{fs}$ yield

$$IMEP_{fs} = 0.273 \times P_{fs}$$

or in this example

$$IMEP_{fs} = 0.273 \times 3500 \text{ kPa} = 955.5 \text{ kPa}$$

It is therefore important to select the minimum pressure transducer range that will satisfy the application in order to provide for the best accuracy and resolution in the

IMEP calculation. For spark-ignited automotive engines a full-scale pressure range of 3500 kPa and a full-scale IMEP of 1400 kPa proved to be appropriate choices. For light aircraft engines a good choice is 7000-kPa pressure and 2800-kPa IMEP; and for diesel engines, 21 000-kPa pressure and 5600-kPa IMEP.

A further constraint is imposed by allowing the ADC to operate at a gain of 2. This limits the maximum ADC input signal to 5 V although the maximum output of the MDAC is 10 V. However, the MDAC output is the product of pressure and piston velocity, and in typical engines the pressure peak falls in the area of low velocity (i.e., near TDC). The product therefore should not exceed 5 V under normal engine operating conditions. The output of the MDAC is available on the front panel of the instrument and can be monitored on an oscilloscope. If the MDAC output exceeds 5 V at any point in the computation, a larger full-scale range must be chosen for the cylinder pressure transducer.

Circuit Description

The circuit schematics for the IMEP instrument are shown in figure 10. The power supply schematic is shown in figure 10(a). The IMEP instrument is packaged in a Tektronix TM-500 blank module and used in conjunction with a Tektronix RTM506 Option 2 module rack. The details of the internal circuitry of the module rack will not be discussed; however, this information is available from the manufacturer. The module rack contains the power transformer, rectifiers, filter capacitors, and uncommitted power transistors for use as series pass elements. Unregulated +33 and -33-V and +11-V power is bused across the module rack backplane and is available to all modules.

The card-edge connector numbers shown in figure 10(a) follow the numbering of the manufacturer. U21 is a positive 15-V three-terminal voltage regulator. D1 is a 33-V zener diode used to protect U21 from voltage transients. C1 is used as an input filter and C7 is used as an output filter. R1 is used as a dropping resistor to limit the power dissipation of U21. U22 is a negative 15-V three-terminal voltage regulator. The associated circuitry functions as described for U21. U23 is a positive 5-V three-terminal voltage regulator used in conjunction with the uncommitted PNP power transistor located in the module rack. The current-sharing ratio between the power transistor and U23 is determined by the beta of the power transistor. R3 is used to allow U23 to vary the base drive voltage of the power transistor. C3 is used to ensure stability and C4 is used as an output filter.

The display voltage, VDD, is derived by using the NPN power transistor in the module rack in an emitter-follower arrangement. VDD therefore is 5 V minus the

base-emitter drop of the power transistor, or approximately 4.5 V. Although the displays are designed for 5-V operation, they incorporate on-chip current sources for the light-emitting diodes (LED's). Thus the brightness of the display is not affected by the lower operating voltage.

Three separate grounding systems are maintained in the IMEP module. They are digital logic ground, analog signal ground, and display ground. The grounds are connected at the point of entry to the module. This separate grounding system was employed to reduce noise in the analog portions of the circuitry.

The remaining circuitry in figure 10(a) shows the wiring to the front-panel input and output connectors, the control switches, and the numerical display. C6 is used to provide ac coupling of the pressure input signal in order to negate the drifting effects of the charge amplifier signal conditioner used in conjunction with piezoelectric transducers. C6 is bypassed when the instrument is in the calibrate mode. The location of the front-panel components and the circuit-board orientation is shown in figure 11.

The main computational circuitry is shown in figure 10(b). U1, U2, and U3 form the memory address decoder. The crank position information θ is presented to the instrument on card-edge connectors as shown. This information is in the form of a 10-bit binary number represented by the symbols $\overline{B0}$ (least significant bit, LSB) through B9 generated by external circuitry that includes an absolute-position optical-shaft-angle encoder and associated circuitry. The signals G8, G8, and 720 are also generated by the external circuitry. B0 through B9 assume the "all ones" condition at $\theta = 0^\circ$ and at $\theta = 360^\circ$. The "all zeroes" condition is achieved just prior to $\theta = 360^\circ$ and $\theta = 720^\circ$. B9 is the logic inverse of $\overline{B9}$. G8 and its inverse $\overline{G8}$ have the same period as B9 and $\overline{B9}$ but are 90 crankangle degrees out of phase with them. The signal 720 is logic "zero" from θ of 0 to 180° , logic "one" from θ of 180° to 540° , and logic "zero" from 540° to 720° . $\overline{B10}$ is formed from the exclusive OR of 720 with B9 by one gate of U2. $\overline{B10}$ is then the most significant binary bit of θ and has a period of 720° . Figure 12 shows the timing diagram of these signals.

A simple modification to the basic IMEP instrument circuit will allow the computation to be performed only during either the lower (pumping) loop or the upper (compression-expansion) loop. Referring to figure 10(b), to compute only during the compression-expansion portion of the cycle, disconnect U20 pin 3 from the VCC and connect it to U2 pin 1. To compute only during the exhaust-intake portion of the cycle, disconnect U20 pin 1 from ground and connect it to U2 pin 1. The calibration procedure remains the same.

U4 is a 256-word-by-8-bit read-only memory containing the binary magnitude of the function $dV/d\theta$. An ultraviolet, erasable, electrically programmable

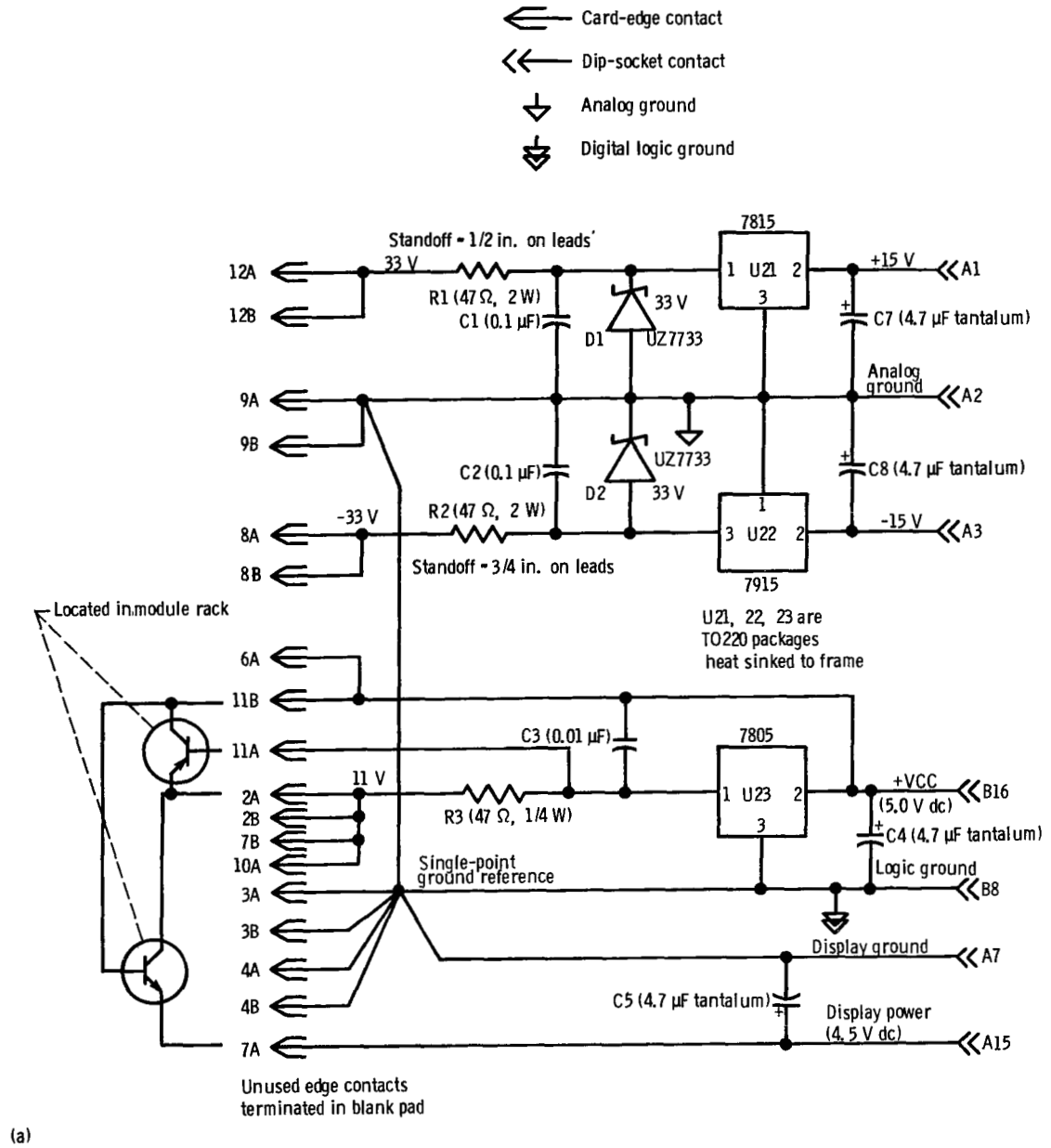

(a) Power supply schematic (board 1) and front panel wiring diagram.

Figure 10. - Circuit schematics for IMEP instrument.

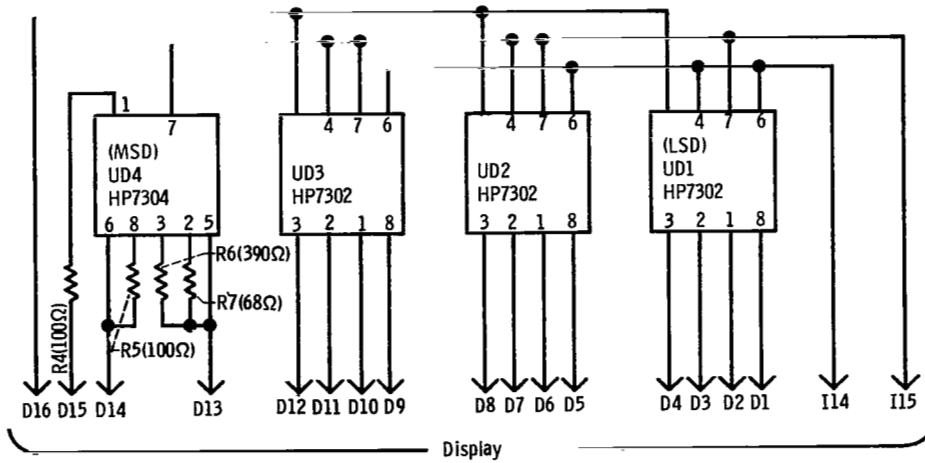

Note: R4, R5, R6, and R7 are located on display board. See +1999 display drawing for cross reference.

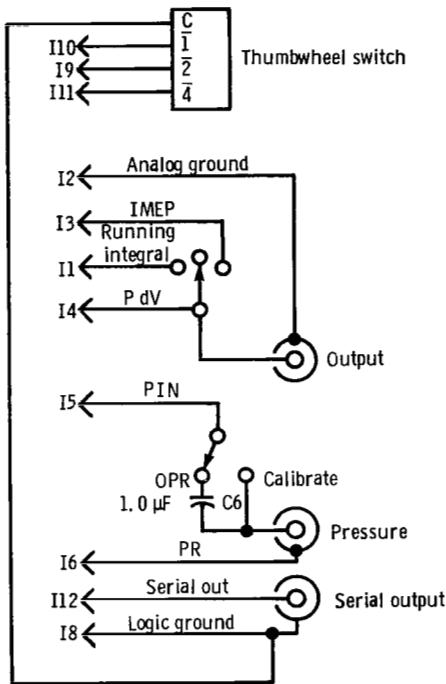

(a) Concluded.

Figure 10. - Continued.

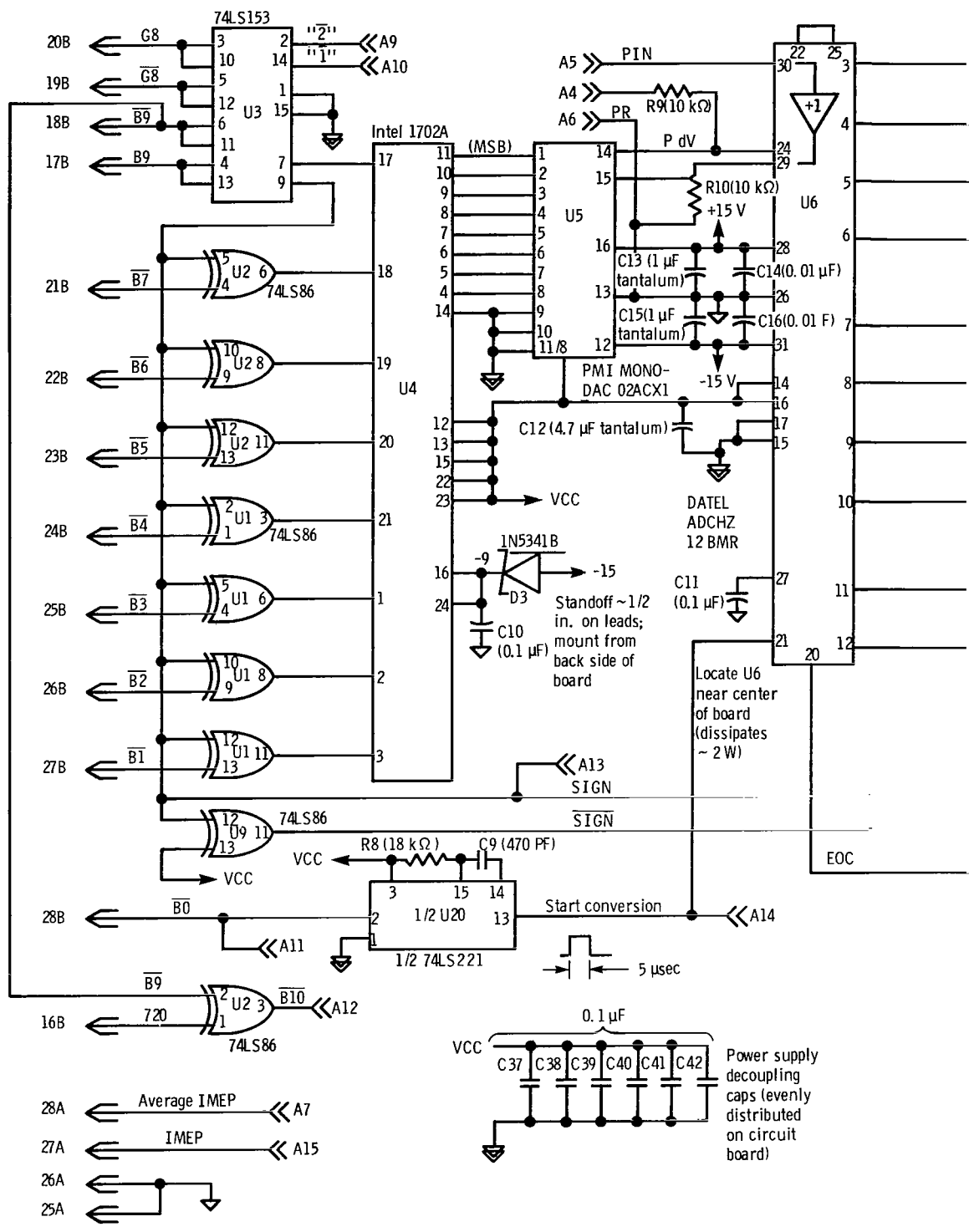

(b)

(b) Logic diagram

Figure 10. -

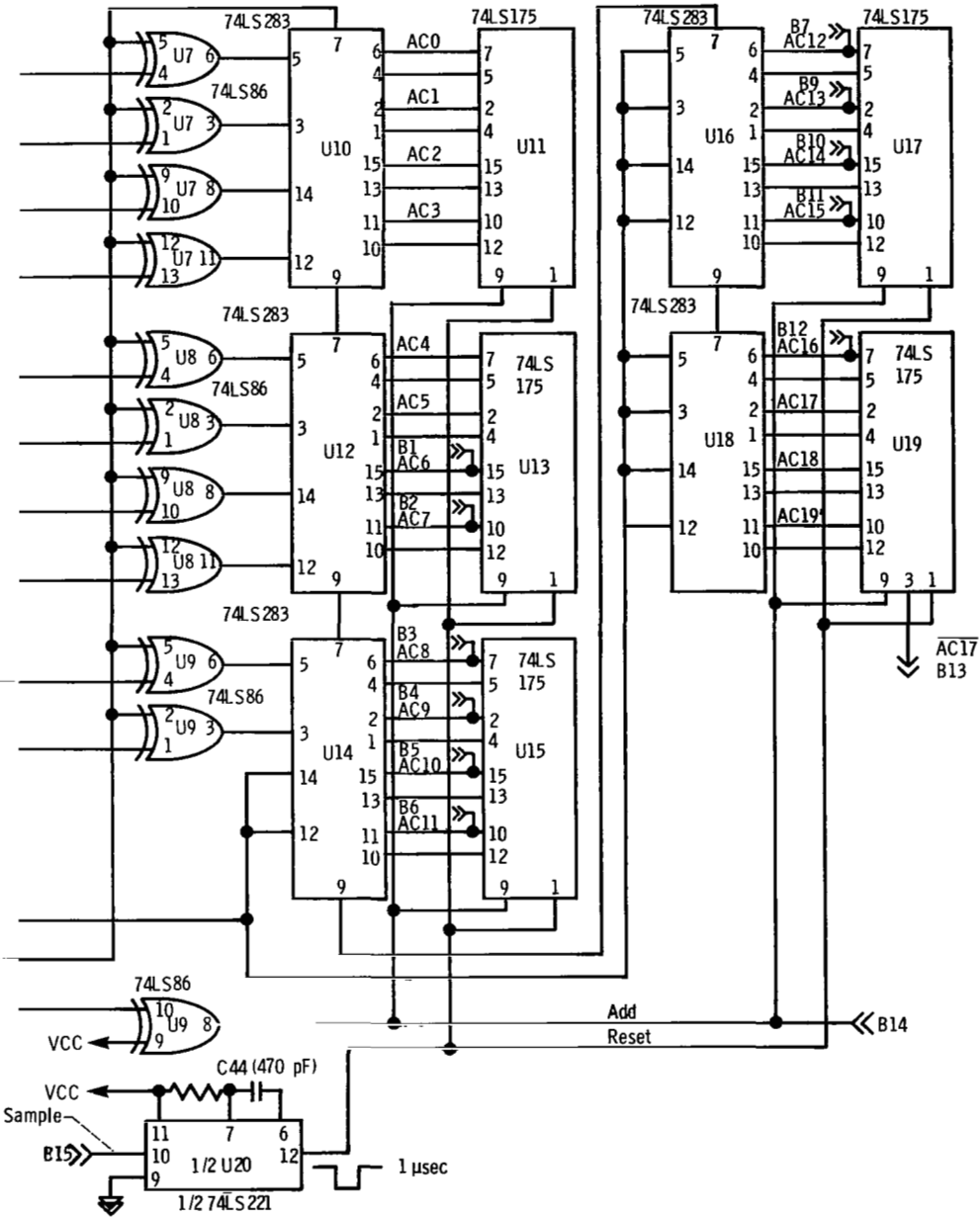

(board 1).

Continued.

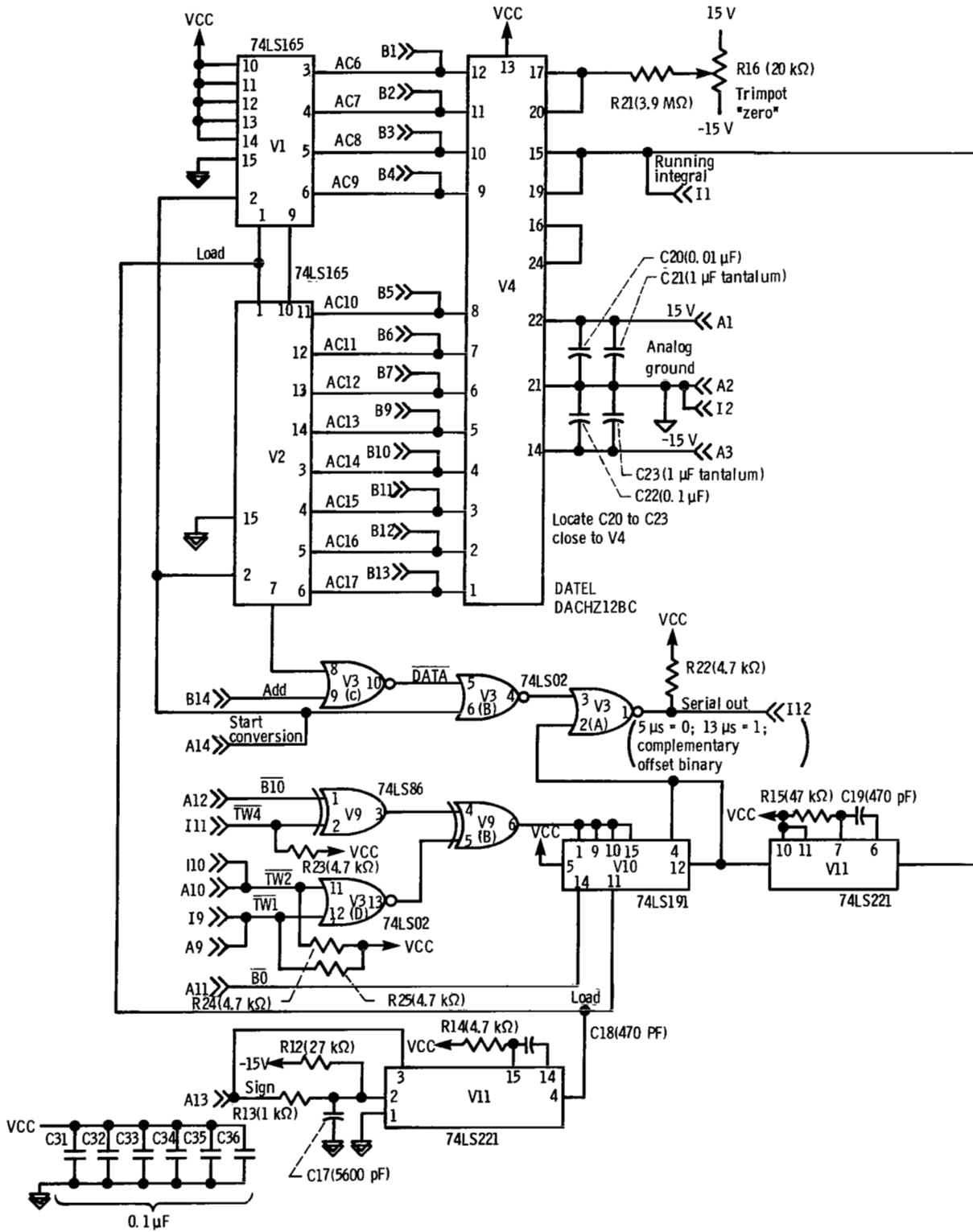

(c) Logic diagram

Figure 10. -

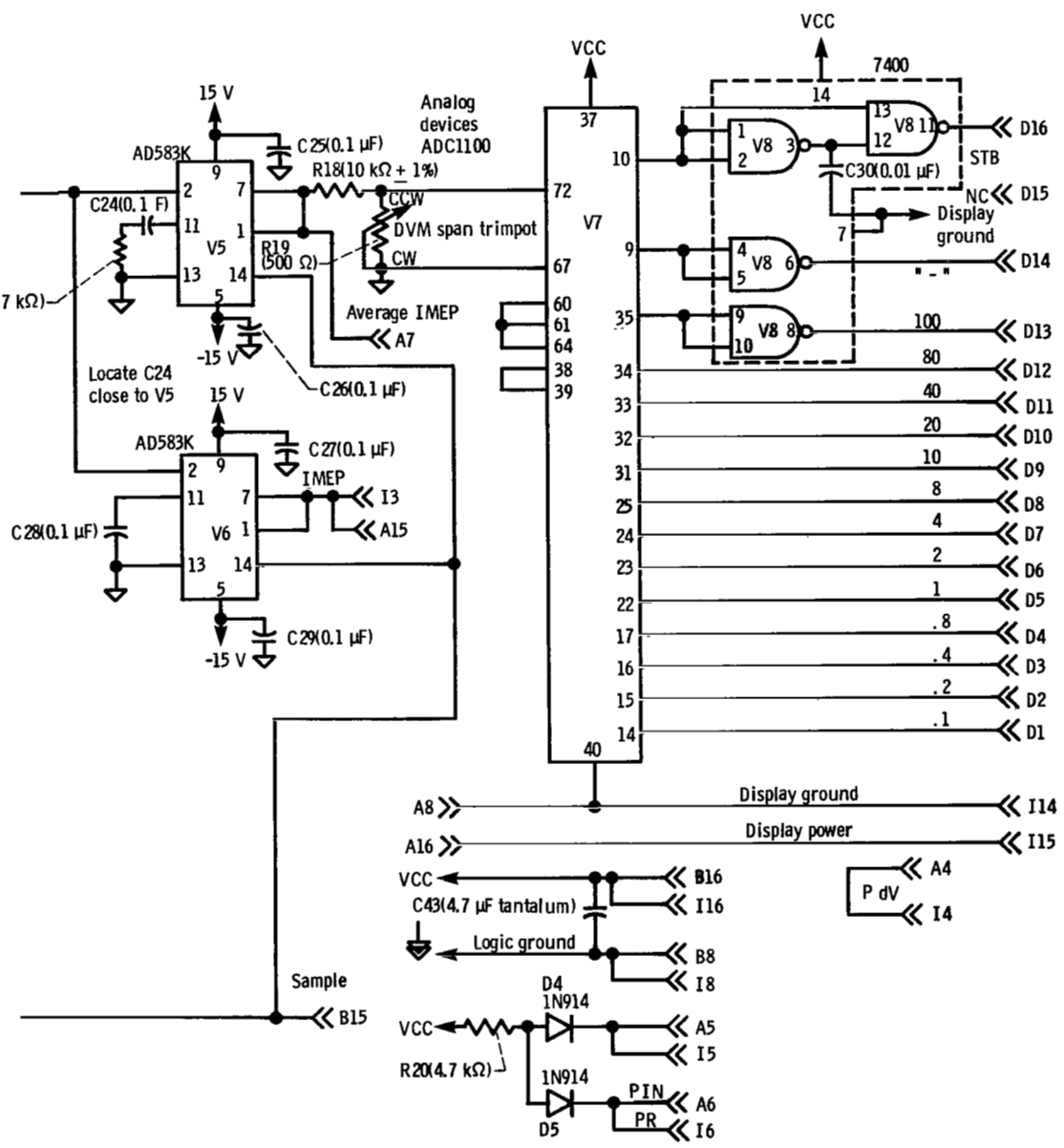

(board 2).

Concluded.

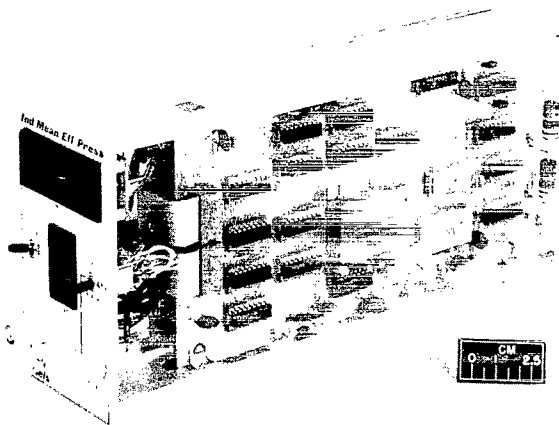

Figure 11. - IMEP module.

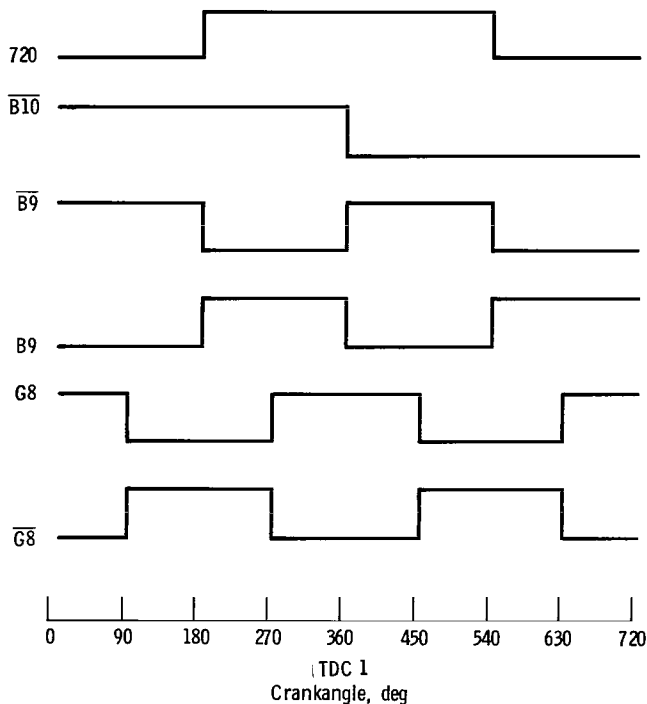

Figure 12. - Timing diagram.

memory (1702A) was used, but less expensive permanently programmed memories could also be used. D3 is a 6.3-V, 1-W zener diode used to derive the -9-V supply needed by U4 from the module's -15-V supply. C10 is used as a decoupling capacitor. The seven least significant bits of the address of U4 are the signals B0 through B7 or their logic inverses as determined by the exclusive OR gates of U1 and U2. This inversion is determined by the signal "SIGN." When SIGN is logic one, the signals are inverted; when SIGN is logic zero, the signals are not inverted. The function of SIGN and the

exclusive OR gates is to make a seven-bit reflected binary code. A reflected code is one that has the normal progression of count reversed at the all-ones and all-zeroes conditions. Thus the address progresses from 0 (all zeroes) to 127 (all ones) and then reverses and progresses from 127 back to 0, at which point the progression is reversed again. This coding system for the memory address was used to take advantage of the fact that in engines that exhibit negligible eccentricity the magnitude values of $dV/d\theta$ are the same when the piston goes from BDC to TDC as they are when it goes from TDC to BDC. The sign of $dV/d\theta$ is determined by the direction of piston motion. This coding scheme allows all eight bits of the memory words to be used as magnitude bits rather than forcing one bit to carry the sign information. The most significant bit (MSB) of the memory address and the SIGN signals are chosen from G8, $\overline{G8}$, B9, or $\overline{B9}$ depending on which cylinder of the engine the $dV/d\theta$ is being generated for. The selection of cylinder is made with the front-panel cylinder-select thumbwheel switch, which controls the signals "1" and "2" of digital multiplexer U3. For cylinder one, signal 2 is logic zero (low) and signal 1 is logic one (high). Then the MSB of the address is signal $\overline{G8}$ and SIGN is signal $\overline{B9}$. The total eight-bit address of the memory for cylinder one starts at 000 (all 8 bits zero) at crankangle 0° (TDC) and progresses to 255 (all ones) at 180° (BDC). At this time, SIGN goes low and causes the seven least significant bits of the address to be reflected. The address will then progress from 255, reaching 000 at 360° (TDC). The signals used for the address MSB and the SIGN for the various cylinders are shown in table I. The net result is that the memory address is shifted 90 crankangle degrees for every numerical increase in the cylinder select switch.

The contents of memory U4 are applied as the digital inputs to the multiplying-digital-to-analog converter (MDAC) U5. The analog input to U5 is the scaled pressure signal P . The function of MDAC U5 is to multiply the digital input $dV/d\theta$ from the memory by the analog signal P and produce the analog product $P dV/d\theta$. U5 is a 10-bit converter (i. e., monotonic to 10 bits). However, only eight bits are used, so a converter

TABLE I. - ADDRESS MOST SIGNIFICANT BIT AND "SIGN" SIGNALS FOR VARIOUS CYLINDERS

Cylinder	"2"	"1"	Most significant bit	SIGN
1,5	Low	High	$\overline{G8}$	$\overline{B9}$
2,6	High	Low	B9	$\overline{G8}$
3,7	High	High	G8	B9
4,8	Low	Low	$\overline{B9}$	G8

having nine-bit monotonicity could be used and still be accurate to within $\pm 1/2$ LSB. U6 is a 12-bit analog-to-digital converter. Located within the ADC is a high-input-impedance, unity-gain buffer amplifier (pin 30 input and pin 29 output). The pressure signal P_{in} uses this buffer amplifier so that the calibration potentiometer (R10) does not load the signal source. Signal PR is the low or ground side of the pressure input and is connected to the analog ground point right at the converters U5 and U6 in order to eliminate any possible dc offset due to analog ground currents within the module. Capacitors C11 to C16 are used as power supply decoupling capacitors.

U7, U8, and U9 are 74LS86 quad exclusive OR gates. U7, U8, and one-half of U9 are used as controlled inverters for the digitized $P dV$ output signals of the ADC. The sign of the computation is controlled by the signal SIGN. Remember that up to this point the computation is still coded in sign-magnitude form. At the output of U7, U8, and U9 the signal is now in one's-complement form for negative $P dV$ terms. In addition, sign is also applied as the carry-in signal to adder U10. This in effect generates a two's-complement code for negative $P dV$ terms so that they can be subtracted by two's-complement addition. U10, U12, U14, U16, and U18 are 74LS283 quad two's-complement adders. U11, U13, U15, U17, and U19 are 74LS175 quad registers with both true and false outputs. These adders and registers together form a 20-bit, binary two's-complement accumulator that stores the running summation of $P dV$ terms. Only 12 bits of the accumulator output are used, AC6 through AC17. Note that the complement of AC17 ($\overline{AC17}$) is actually used for the most significant bit. This converts the two's-complement code at the output of the accumulator to complementary bipolar offset binary coding, which is the input code required by the digital-to-analog converter in the output signal processor section of the instrument. This is discussed in more detail later.

One of the gates of U9 is used to invert SIGN, and one is used to invert the end convert (EOC) output of the ADC, which is then used to latch the running summation data in the accumulator. Since only 10 bits of the 12-bit ADC are used, there is a delay equal to two-bit conversion times between the time when the most significant 10 bits are converted and the time when EOC is generated. For the converter used, this time amounts to approximately 1.5 μsec . This is more than sufficient time for the addition to be performed.

U20 is used to provide timing pulses. One-half of U20 uses the LSB of the crankangle data as an input and produces a 5- μsec positive-going pulse on the leading edge of $\overline{B0}$. The ADC is triggered on the trailing edge of this output pulse. Thus there is a 5- μsec delay between the change in crankangle and the initiation of conversion.

This delay is necessary to allow for ROM access (1 μsec) and MDAC settling time (4 μsec). The second half of U20 is used to provide a 1- μsec negative-going pulse, which is used to reset the accumulator at the end of an engine combustion cycle. The input signal "SAMPLE" is derived from circuitry shown in figure 10(c) and is discussed later.

The output signal processor circuitry is shown in figure 10(c). The digitized running summation of $P dV$ terms from the accumulator is applied as the input to digital-to-analog converter V4 and to shift registers V1 and V2. V4 is used to produce an analog representation of the accumulator content at all times. Shift registers V1 and V2 are loaded with the accumulator data each time the engine is at TDC. However, only at TDC nonfiring does this data get passed to the serial output. The signal "LOAD" is generated by V11 in response to the leading edge of SIGN. A resistor-capacitor network consisting of R12, R13, and C17 is used to provide a 2- μsec delay, which allows cylinder decoder networks V9(A), V9(B), and V3(D) to stabilize before counter V10 is loaded. This is necessary because $\overline{B10}$ and SIGN have coincident leading edges for cylinders 1 and 5. Counter V10 is loaded with the number fifteen 2 μsec after TDC nonfiring occurs. The count is then decremented to zero with $\overline{B0}$. The net result is to pass a series of 15 pulses, one for each accumulator bit plus three extra, to the serial output. The pulses are 13 μsec long if the accumulator bit was a logic one and 5 μsec long if the bit was a logic zero. (The three extra bits are logic ones in this IMEP instrument but are used to carry configuration information in other instruments in the MEIS system.)

At the end of a combustion cycle the running summation of $P dV$ is equal to the IMEP for that cycle. Sample-hold amplifiers V5 and V6 are used to store this analog representation of IMEP. V6 is used in conventional fashion to store the value of IMEP for each cycle. V5 uses R17 and C24 to form a sampled averager network with a time constant of 50 engine cycles. Each time a combustion cycle ends, V11 produces a 10- μsec SAMPLE pulse. Since the time constant of R17 and C24 is 500 μsec , it takes 50 such pulses to achieve one time constant. Thus the output of V5 is the average IMEP with a time constant of 50 combustion cycles, independent of engine rpm. Digital voltmeter V7 is used to display the average IMEP on the front panel of the instrument. Integrated circuit V8 is used to provide a strobe and additional drive signals for the numerical displays.

At the end of the sample interval the SAMPLE signal goes high and causes V20 to generate a 1- μsec negative-going pulse, which resets the accumulator to zero.

The resistor-diode-capacitor network consisting of R20, D4, D5, and C6 is used to provide dc restoration of the pressure transducer signal (PIN). Thus, the effects of

offset and drift inherent in piezoelectric transducers are compensated for. Capacitor C6 is bypassed when in the calibration mode to allow for the use of a dc calibration signal, as discussed earlier.

Performance

The IMEP instrument was tested on several research engines. The IMEP's as measured by the instrument were compared with those backcalculated from BMEP and motoring friction data. On a rotary combustion engine the difference averaged about 6 percent (ref. 2). However, in that engine test only one of the combustion spaces (out of 6) was instrumented, and the friction was assumed to be equally divided among the six spaces.

Better agreement was obtained when the tests were done on a single-cylinder engine, where all of the important parameters could be readily measured. The engine used was an AVL 521 diesel with a full-power output of 65 kW. Data were taken at four engine speeds over a range of IMEP from approximately 1500 to 2500 kPa. The results are shown in figure 13.

These figures show measured and back-calculated IMEP plotted against fuel flow. The measured IMEP and the back-calculated IMEP are in good agreement for engine speeds of 1500, 2500, and 3000 rpm. The 2000-rpm-engine-speed data show a larger difference than for the other speeds. The cause of this larger difference is not known but is suspected to be an underestimation of the back-calculated IMEP. Figure 14 shows the percentage difference between the measured

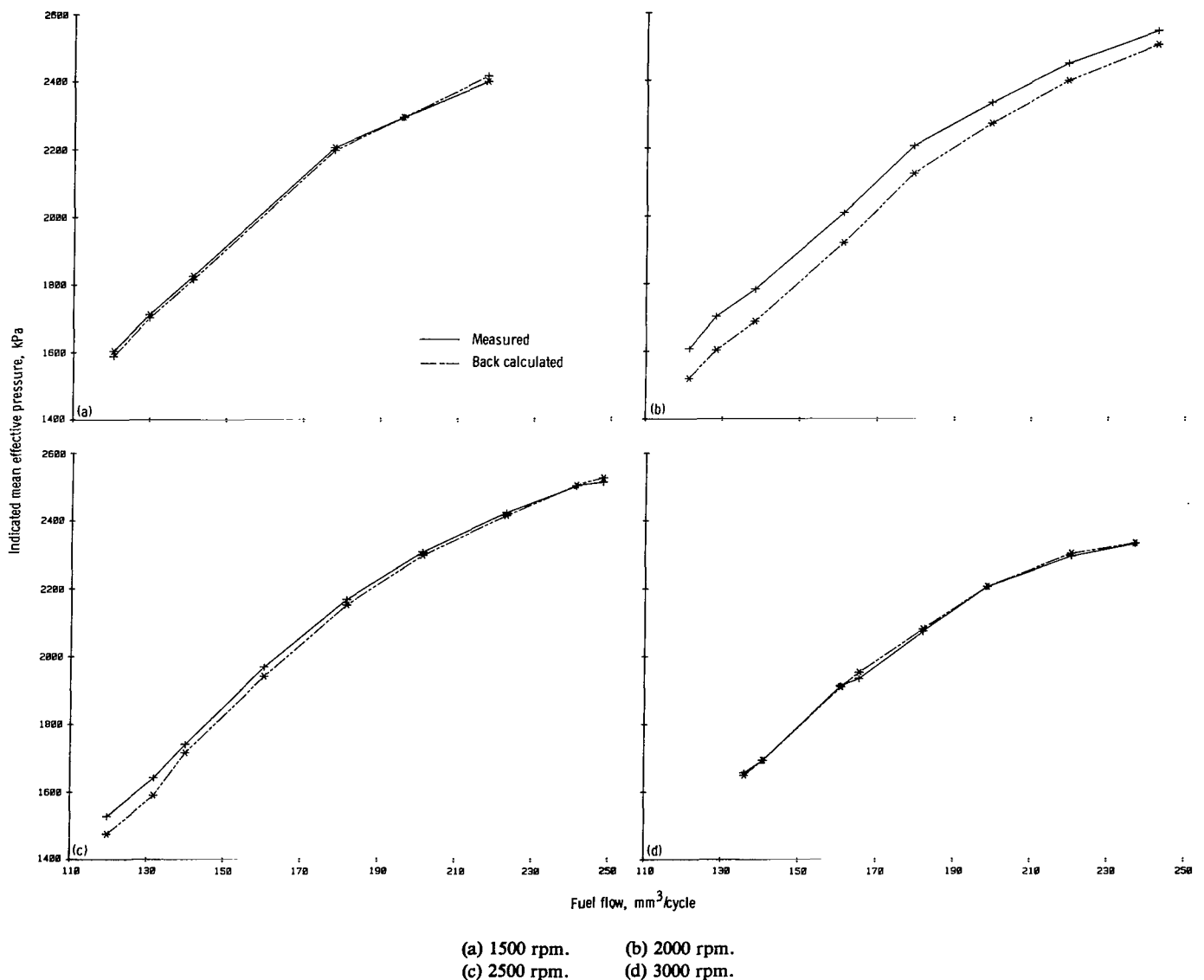

Figure 13. — IMEP data taken on AVL 521 diesel engine at four engine speeds.

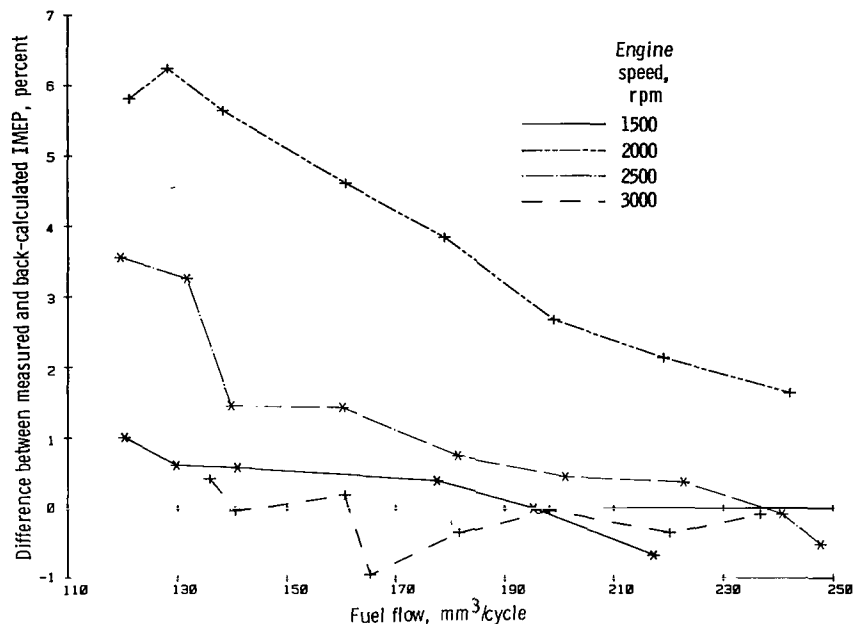

Figure 14. — Percentage difference between measured and back-calculated IMEP as a function of fuel flow.

IMEP and the back-calculated IMEP plotted against fuel flow. The percentage difference decreases with increased IMEP. This indicates that the basic accuracy of the IMEP instrument is characterized as a percent of full scale rather than a percent of reading. This result is to be expected since all of the major components and the pressure transducer itself have accuracies specified as percent of full scale. The average difference for the 30 test points that were examined was 1.1 percent, which was 0.5 percent of the full-scale range of 5600 kPa.

The IMEP calculation is extremely sensitive to the proper phasing of the cylinder pressure waveform and the position of the crankshaft. Our tests have shown that this sensitivity is about 5 percent of reading per degree of encoder rotation for spark-ignited engines of moderate compression ratio. For high-compression diesel engines this sensitivity is about 20 percent per degree of encoder rotation.

It is critically important that a high-frequency-response pressure transducer be used for the cylinder pressure measurement. A quartz piezoelectric transducer is recommended for best results. Adequate cooling of the transducer is very important. Because of capillary tube resonance effects on the frequency response of the pressure transducer, it is recommended that the transducer be flush mounted in the head of the engine.

Conclusions

A new instrument capable of measuring IMEP on a real-time cycle-by-cycle basis has been successfully designed, tested, and demonstrated. Data from a single-cylinder diesel engine show an average error of 1.1 percent between IMEP as measured by the new instrument and that back calculated from BMEP and motoring friction data.

Lewis Research Center
National Aeronautics and Space Administration
Cleveland, Ohio, May 9, 1983

References

1. Rice, W. J.; and Birchenough, A. G.: A Modular Instrumentation System for Real-Time Measurements and Control on Reciprocating Engines. NASA TP-1757, 1980.
2. Schock, H. J.; Rice, W. J.; and Meng, P. R.: Experimental Analysis of IMEP in a Rotary Combustion Engine. SAE Paper 810150, Feb. 1981.

1. Report No. NASA TP-2238		2. Government Accession No.		3. Recipient's Catalog No.	
4. Title and Subtitle Development of an Instrument for Real-Time Computation of Indicated Mean Effective Pressure				5. Report Date January 1984	
7. Author(s) William J. Rice				6. Performing Organization Code 505-40-62B	
9. Performing Organization Name and Address National Aeronautics and Space Administration Lewis Research Center Cleveland, Ohio 44135				8. Performing Organization Report No. E-1650	
12. Sponsoring Agency Name and Address National Aeronautics and Space Administration Washington, D.C. 20546				10. Work Unit No.	
15. Supplementary Notes				11. Contract or Grant No.	
16. Abstract A new instrument capable of computing in real time the per-cycle indicated mean effective pressure (IMEP) of internal combustion engines and compressors has been designed and tested. The values of IMEP obtained with the new instrument were found to be in excellent agreement with values obtained by previous postrun data-reduction techniques.				13. Type of Report and Period Covered Technical Paper	
17. Key Words (Suggested by Author(s)) Electronic equipment Engine analyses Engine monitoring instruments			14. Sponsoring Agency Code		
19. Security Classif. (of this report) Unclassified			18. Distribution Statement Unclassified - unlimited STAR Category 33		22. Price* A02
20. Security Classif. (of this page) Unclassified		21. No. of pages 21			

National Aeronautics and
Space Administration

Washington, D.C.
20546

Official Business
Penalty for Private Use, \$300

THIRD-CLASS BULK RATE

Postage and Fees Paid
National Aeronautics and
Space Administration
NASA-451



6 1 1J,D, 840120 S00903DS
DEPT OF THE AIR FORCE
AF WEAPONS LABORATORY
ATTN: TECHNICAL LIBRARY (SUL)
KIRTLAND AFB NM 37117

NASA

POSTMASTER: If Undeliverable (Section 158
Postal Manual) Do Not Return
