

General Disclaimer

One or more of the Following Statements may affect this Document

- This document has been reproduced from the best copy furnished by the organizational source. It is being released in the interest of making available as much information as possible.
- This document may contain data, which exceeds the sheet parameters. It was furnished in this condition by the organizational source and is the best copy available.
- This document may contain tone-on-tone or color graphs, charts and/or pictures, which have been reproduced in black and white.
- This document is paginated as submitted by the original source.
- Portions of this document are not fully legible due to the historical nature of some of the material. However, it is the best reproduction available from the original submission.

DRA

DEPARTMENT OF ELECTRICAL ENGINEERING
SCHOOL OF ENGINEERING
OLD DOMINION UNIVERSITY
NORFOLK, VIRGINIA

INVESTIGATION OF DESIGN CONSIDERATIONS
FOR A COMPLEX DEMODULATION FILTER

By

J. W. Stoughton, Principal Investigator

(NASA-CR-173295) INVESTIGATION OF DESIGN
CONSIDERATIONS FOR A COMPLEX DEMODULATION
FILTER Final Report, 6 Jun. - 6 Sep. 1979
(Old Dominion Univ., Norfolk, Va.) 14 p
HC A02/MF A01

N84-17195

Unclass

CSCI 22A G3/12 18349

Final Report

For the period June 6 to September 6, 1979

Prepared for the
National Aeronautics and Space Administration
Langley Research Center
Hampton, Virginia

Under

Research Grant NAS-1-15648

Task Authorization No. 16

Richard N. Couch, Technical Monitor
FED-Spacecraft Instrn. Sys. Section



January 1984

OLD DOMINION UNIVERSITY RESEARCH FOUNDATION



DEPARTMENT OF ELECTRICAL ENGINEERING
SCHOOL OF ENGINEERING
OLD DOMINION UNIVERSITY
NORFOLK, VIRGINIA

INVESTIGATION OF DESIGN CONSIDERATIONS
FOR A COMPLEX DEMODULATION FILTER

By

J. W. Stoughton, Principal Investigator

Final Report
For the period June 6 to September 6, 1979

Prepared for the
National Aeronautics and Space Administration
Langley Research Center
Hampton, Virginia 23665

Under
Research Grant NAS-1-15648
Task Authorization No. 16
Richard N. Couch, Technical Monitor
FED-Spacecraft Instrn. Sys. Section

Submitted by the
Old Dominion University Research Foundation
P.O. Box 6369
Norfolk, Virginia 23508



January 1984

INVESTIGATION OF DESIGN CONSIDERATIONS
FOR COMPLEX DEMODULATION FILTER

By

J. W. Stoughton*

This reports presents results accomplished for NASA grant NAS-1-15648, task authorization number 16. The major objective of the work was to develop the digital design of an adaptive digital filter to be employed in the processing of microwave remote sensor data. In particular, a complex demodulation approach (ref. 1), was developed to provide narrow band-power estimation for a proposed Doppler scatterometer system. This scatterometer system was considered for application in the proposed National Oceanographic Survey Satellite (NOSS), as an improvement of SEASAT features (ref. 2). Preliminary research that leads to the theoretical basis for the complex demodulation approach has been reported by Stoughton (ref. 3). In the referenced report, a generalized analysis of complex demodulation is presented along with descriptive block diagrams for the digital architecture component of the proposed system.

This informal report presents a summary of a presentation given to the technical monitor at the conclusion of the task period. This summary presents the digital architecture which could be implemented to realize the adaptive filter power estimation.

*Associate Professor, Department of Electrical Engineering, Old Dominion University, Norfolk, Virginia 23508.

II. SYSTEM DESIGN

System Architecture

A conceptual overview of the estimation system is displayed in figure 1. Note that the inphase (I) and quadrature (Q) form a complex signal \underline{U} , where $U_n = I_n + jQ_n$. The subscript denotes the nth sampled value.

The proposed complex demodulation system is shown in figure 2. As previously described (ref. 3), the complex demodulation section performs a complex heterodyning down of a particular spectral region center, ω_k , to base-band. Note that ω_k is the center of the power spectrum band associated with the center of a particular spacial "cell." Subsequent low pass filtering establishes the required selective bandwidth and hence the spacial cell resolution. If the bandwidth of the low pass section is fixed, then modest error in cell resolution will occur due to latitude and ranging effect. If necessary, the bandwidth can be modified to accommodate the latitude effect. This modification can be achieved by varying the coefficient in the representative digital filter section.

The overall structure of the system suggests a "pipelined" realization. That is, each block will process the data then a scheduled series of bus/register transfer coordinated by a dedicated controller. In view of a desired throughput rate of 400 KHZ, efficient register transfers and arithmetic procedures must be performed. These aspects can be met by highly parallel operations, coupled with read-only memory (ROM) table-look up strategies for generating various functions. A more comprehensive system diagram is shown in figure 3. Note that the architecture diagrams are presented for one estimation section. There is one section for each resolution cell (or ω_p).

Complex Demodulation Section

Refer to figure 4. The heterodyned output $U_n(k)$ is derived by a sequence of controlled bus/register negative transfers. This output is the realization of

$$\begin{aligned} U_n(k) &= e^{jW_k n T} * (I_n + jQ_n) \\ &= e^{j\phi_n(k)} * (I_n + jQ_n) \\ &= [I_n \cos \phi_n(k) - Q_n \sin \phi_n(k)] \\ &\quad + j [I_n \sin \phi_n(k) + Q_n \cos \phi_n(k)] \\ &= I_n' + j Q_n' \end{aligned}$$

where $\phi_n(k) = W_k T$

The argument $\phi_n(k)$ is developed iteratively as a mod_k sequence of 8 bits. Control of the two most significant bits allows a table-look up procedure with a 8×1024 bit ROM to select $\sin \phi_n(k)$ and $\cos \phi_n(k)$, respectively. These values are stored in registers B, and A respectively.

The bus/register transfer may be denoted by the following sequence:

1. $A_n \leftarrow \text{ROM}(\cos:\phi_n)$
2. $B_n \leftarrow \text{ROM}(\sin:\phi_n)$
3. $S_n \leftarrow \text{MLPY}(I_n, A_n)$

$$4. \quad S_n \leftarrow S_n - \text{MLPY}(Q_n, B_n)$$

$$5. \quad T_n \leftarrow \text{MLPY}(Q_n, A_n)$$

$$6. \quad T_n \leftarrow T_n + \text{MLPY}(I_n, B_n)$$

Note that MLPY is the operation of a dedicated multiplier unit.

Thus, after 6 microoperations, the registers S_n , and T contain the complex components I_n and Q_n , respectively.

To maintain the 400 kHz throughput, the micro-operations must be performed at a minimum of 2.4 MHz.

Low Pass Filter

The digital filter is based on a third order Butterworth filter. To facilitate a maximum throughput rate, the transfer characteristic, $H(z)$, may be decomposed into three parallel sections where

$$H(z) = Y(z)/\tilde{u}(z)$$

$$H(z) = H_1(z) + H_2(z) + H_3(z)$$

and

$$\begin{aligned} &= \frac{1 + Z^{-1}}{1 - \beta Z^{-1}} + \frac{(\gamma + j\delta)(1 + Z^{-1})}{1 - (\alpha + j\omega_k)Z^{-1}} \\ &+ \frac{(\gamma - j\delta)(1 + Z^{-1})}{1 - (\alpha - j\omega_0)Z^{-1}} \end{aligned}$$

This complex form is desirable for filtering the complex signal $\tilde{u}(z)$. The term ω_0 establishes the filter bandwidth, and the other parameters, α , β , γ , δ , are selected to generate the proper gain and pole zero location for the filter. The block diagram for this parallel realization is presented in figure 5.

Power Estimation Section

The final computational block develops a power estimate, $P(k$ th spacial cell) derived from N complex samples where

$$p(k) = \frac{1}{N-1} \sum_{n=1}^N |\tilde{Y}_n|^2$$
$$= \frac{1}{N-1} \sum_{n=1}^N [(\text{Re}\tilde{Y}_n)^2 + (\text{Im}\tilde{Y}_n)^2]$$

A digital architecture for realizing the power estimation is presented in figure 6. A ROM is employed to provide a "look up" table for the respective squared value of the complex component of \tilde{Y}_n . The estimate of P_k (k th cell or spectral component) is determined by iteratively accumulating N pairs of the \tilde{Y}_n complex component. Subsequent dumping of this value into a data collection system would be administered by the system controller.

SUMMARY

The digital architecture presented is representative of special architecture necessary to accomplish the complex demodulation approach to the scatterometer estimation process. It would be expected that with the advent of VLSI and large scale memories, different strategies might be warranted.

Further study of this type of design should incorporate finite register simulation to evaluate quantization noise and evaluation of the degree-of-freedom of the power estimate.

REFERENCES

1. Godfrey, C., Bingham, M.D., and Tukey, J. W., Modern techniques of power spectrum estimation. IEEE Trans. Audio Electroacoustics, Vol. AV-18, pp. 139-142, June 1967.
2. "An operational satellite scatterometer for wind vector measurements over the ocean," NASA Technical Memorandum, TM X-72672, March 10, 1975.
3. Stoughton, J.W., "Preliminary design of an adoptive digital Doppler filter," Final Report, NASA Contract NAS1-14193-53, July 1979.

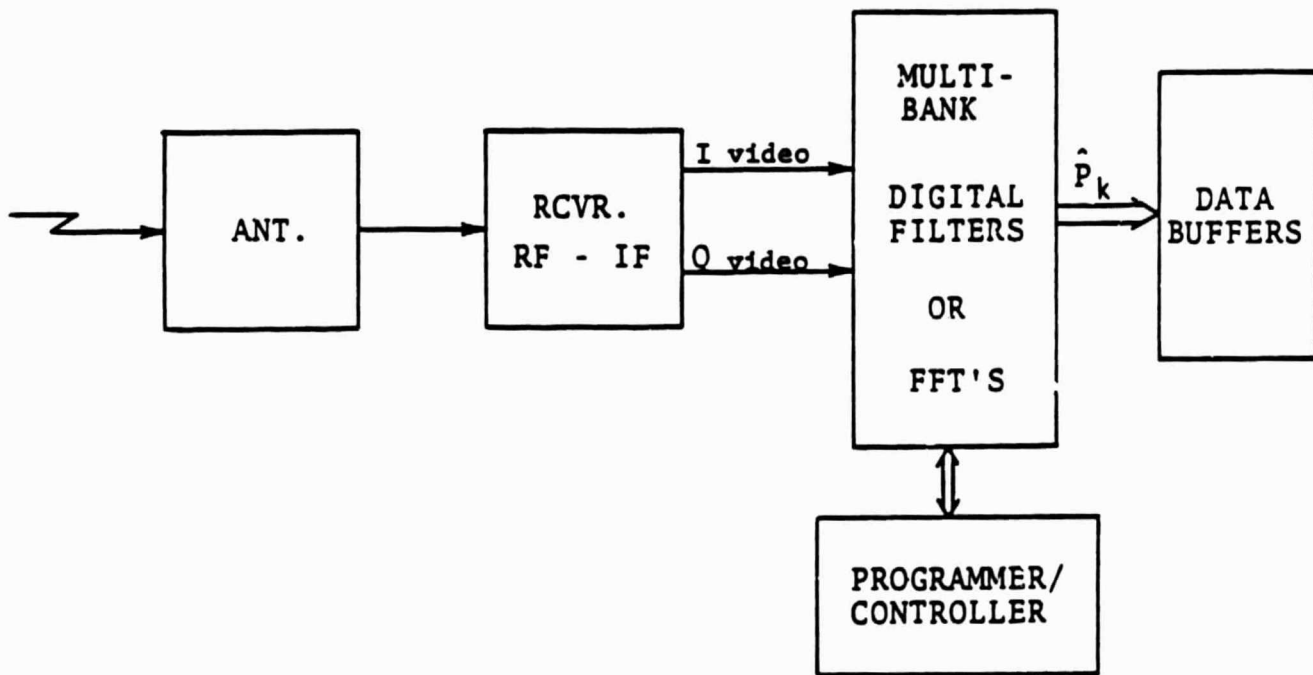

Figure 1. Microwave scatterometer system.

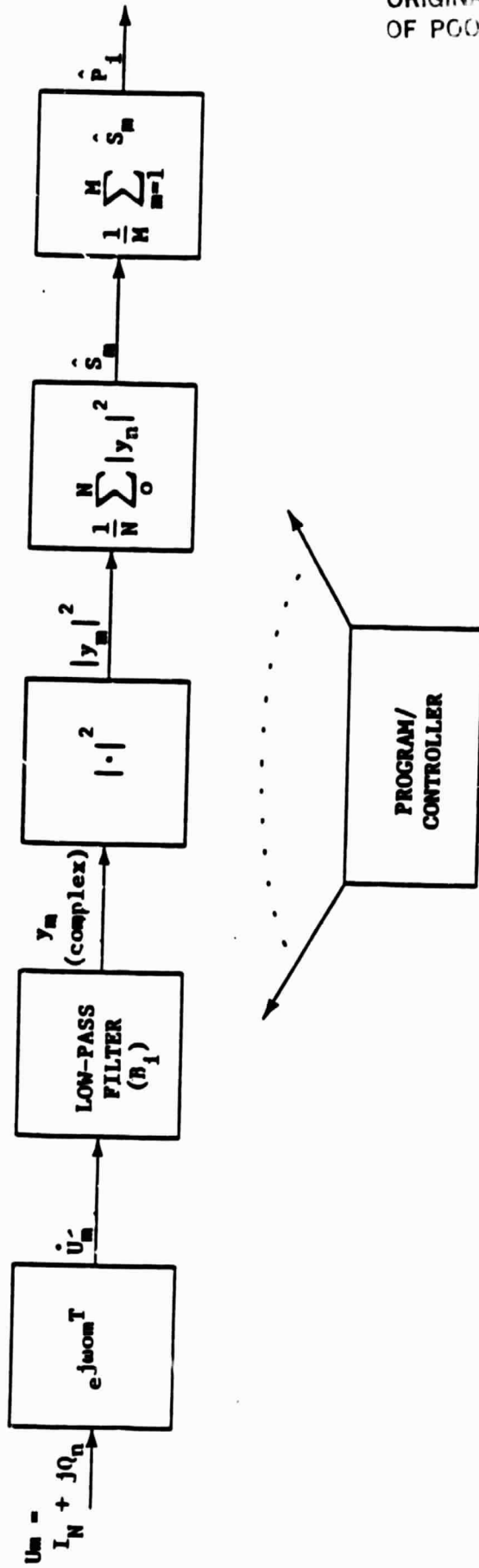

Figure 2. Complex demodulation system.

ORIGINAL PAGE IS
OF POOR QUALITY

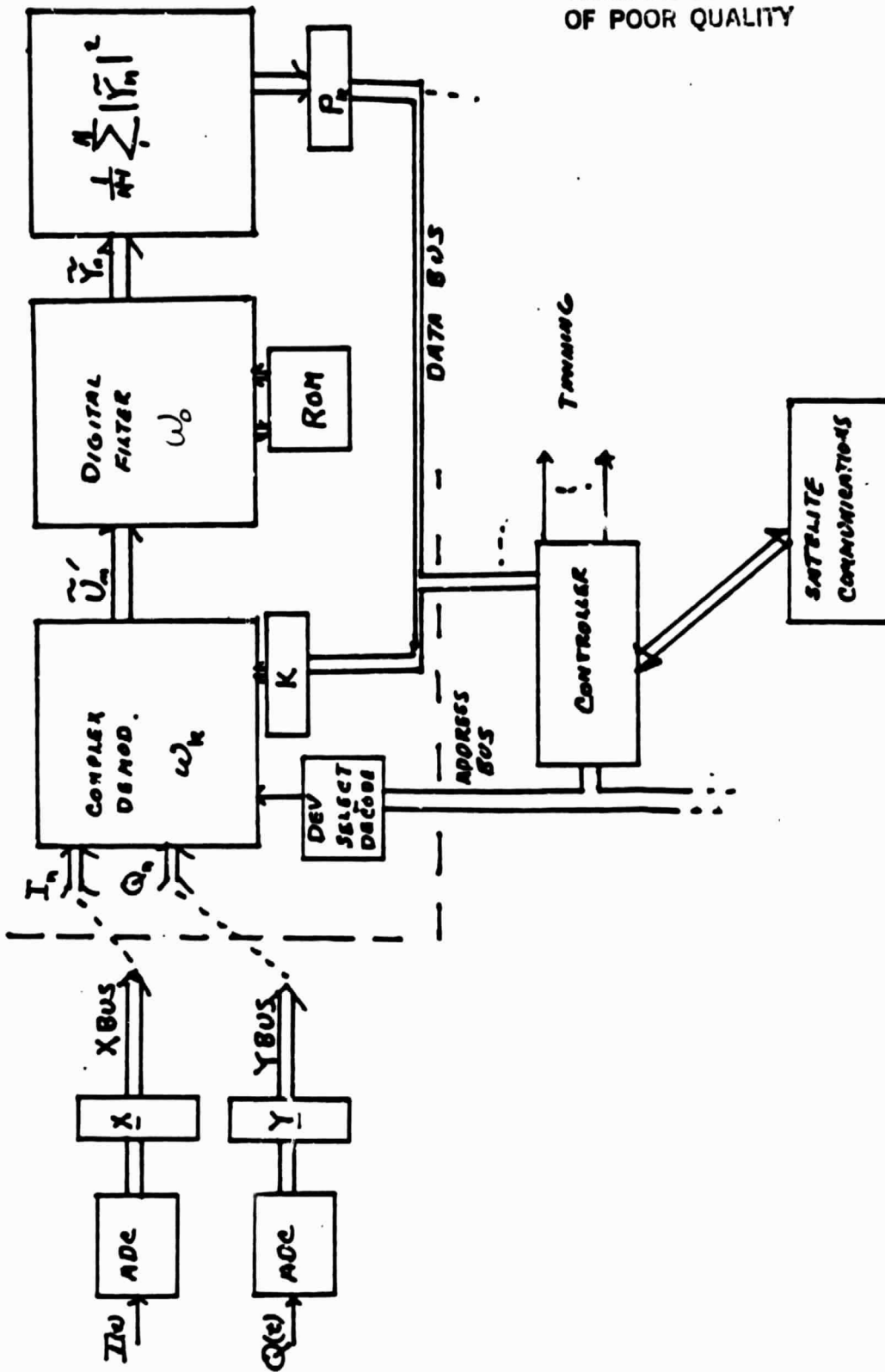

Figure 3. System Block Diagram.

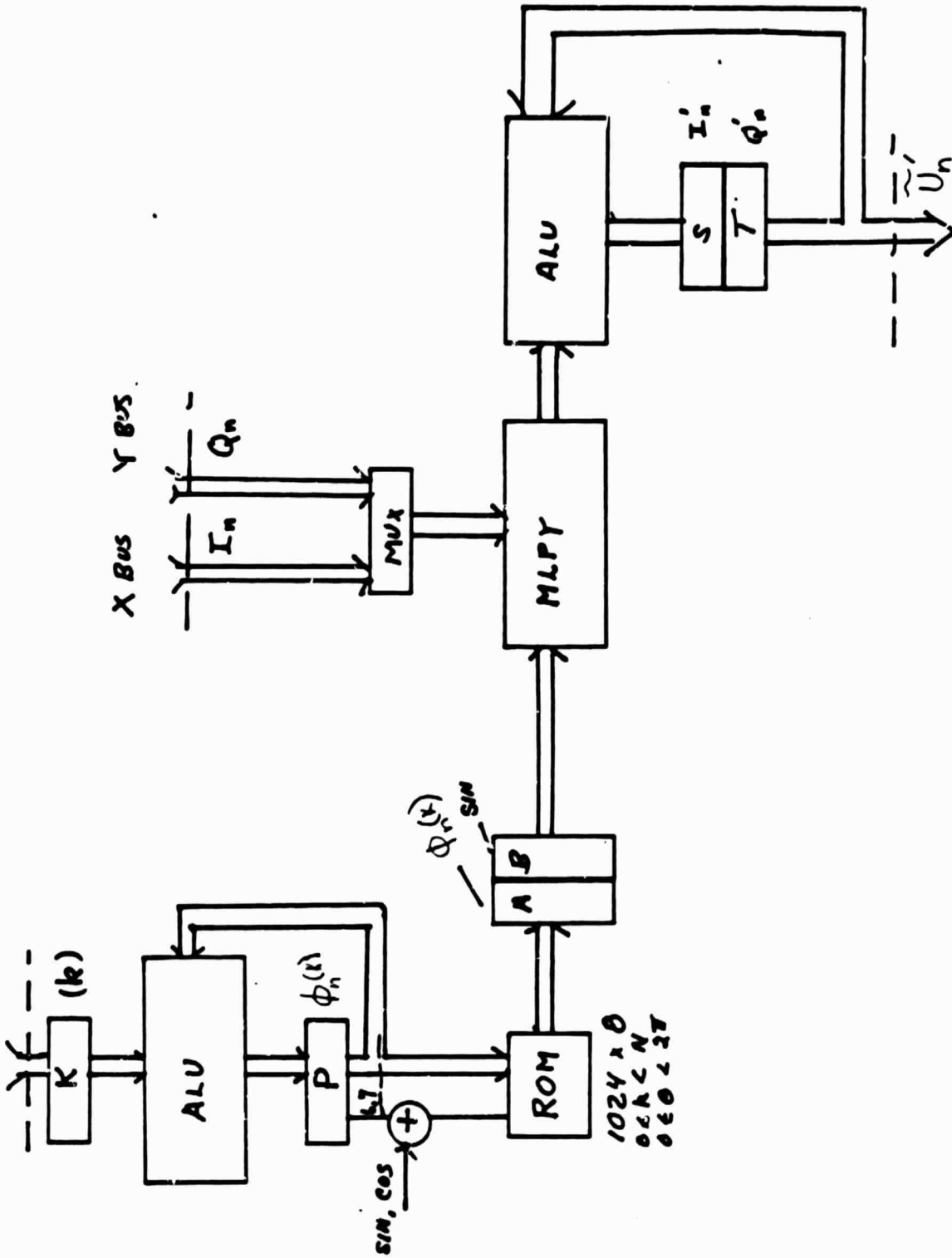

Figure 4. Complex Demodulation Section.

ORIGINAL PAGE IS
OF POOR QUALITY

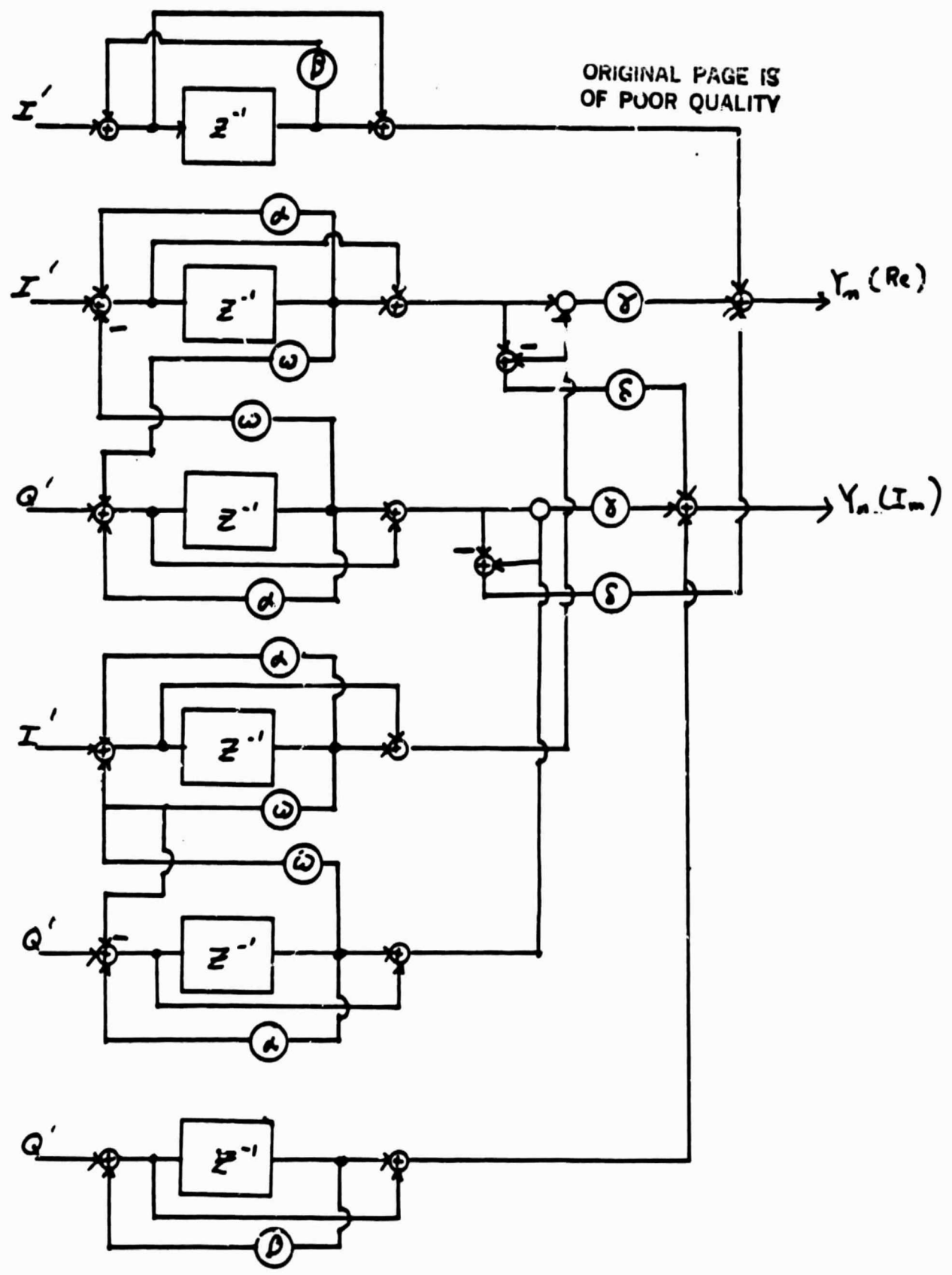
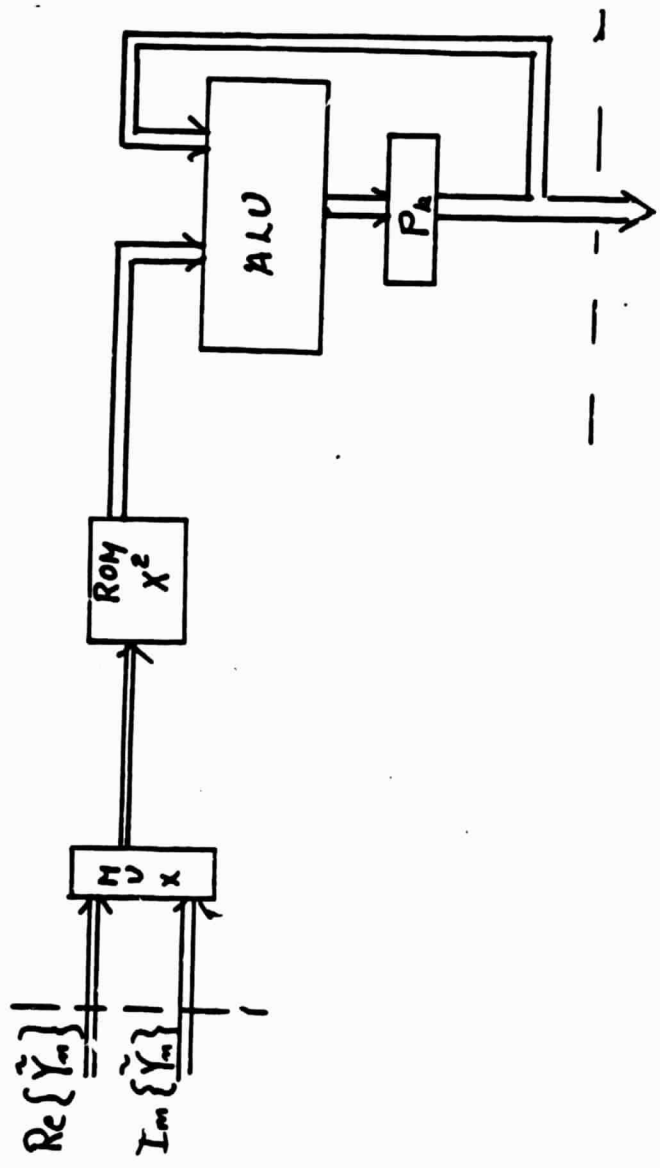

Figure 5. Digital Filter Algorithm for Third Order Butterworth Filter.



$$P_n^2 \leftarrow P_n^m + |Y_n|^2$$

ORIGINAL PAGE 13
OF POOR QUALITY

Figure 6. Power Estimation Section.