

General Disclaimer

One or more of the Following Statements may affect this Document

- This document has been reproduced from the best copy furnished by the organizational source. It is being released in the interest of making available as much information as possible.
- This document may contain data, which exceeds the sheet parameters. It was furnished in this condition by the organizational source and is the best copy available.
- This document may contain tone-on-tone or color graphs, charts and/or pictures, which have been reproduced in black and white.
- This document is paginated as submitted by the original source.
- Portions of this document are not fully legible due to the historical nature of some of the material. However, it is the best reproduction available from the original submission.

DEPARTMENT OF ELECTRICAL ENGINEERING
SCHOOL OF ENGINEERING
OLD DOMINION UNIVERSITY
NORFOLK, VIRGINIA

AIRBORNE ANTENNA PATTERN CALCULATIONS

By

Ali B. Bagherian

and

Roland R. Mielke, Principal Investigator



Final Report
For the period November 1, 1982 to October 31, 1983

Prepared for the
National Aeronautics and Space Administration
Langley Research Center
Hampton, Virginia

Under
Research Grant NSG 1655
Melvin C. Gilreath, Technical Monitor
Flight Electronics Division

(NASA-CR-173284) AIRBORNE ANTENNA PATTERN
CALCULATIONS Final Report, 1 Nov. 1982 - 31
Oct. 1983 (Old Dominion Univ., Norfolk, Va.)
106 p HC A06/MF A01 CSCI 20N

N84-17436

Unclass
G3/32 18318

December 1983



DEPARTMENT OF ELECTRICAL ENGINEERING
SCHOOL OF ENGINEERING
OLD DOMINION UNIVERSITY
NORFOLK, VIRGINIA

AIRBORNE ANTENNA PATTERN CALCULATIONS

By

Ali B. Bagherian

and

Roland R. Mielke, Principal Investigator

Final Report
For the period November 1, 1982 to October 1983

Prepared for the
National Aeronautics and Space Administration
Langley Research Center
Hampton, Virginia

Under
Research Grant NSG 1655
Melvin C. Gilreath, Technical Monitor
Flight Electronics Division

Submitted by the
Old Dominion University Research Foundation
P.O. Box 6369
Norfolk, Virginia 23508



December 1983

ABSTRACT

Use of calculation program START and modeling program P3D to produce radiation patterns of antennas mounted on space station is discussed. Basic components of two space stations in the early design stage are simulated and radiation patterns for antennas mounted on the modules are presented.

ACKNOWLEDGMENT

The authors greatly acknowledge the guidance, help and encouragement provided by Mr. Melvin C. Gilreath, of the Flight Electronics Division of NASA/Langley Research Center, throughout the grant period.

TABLE OF CONTENTS

	<u>Page</u>
ABSTRACT.....	iii
ACKNOWLEDGEMENT.....	iv
SECTION I. INTRODUCTION.....	1
SECTION II. Simulation of Main Module.....	2
SECTION III. Test Patterns for Proposed Space Stations in early design stage.....	3
III.1. Introduction.....	3
III.2. Main module with two long solar panels.....	3
III.3. Three modules with two diagonal solar panels and bottom truss platform.....	4
REFERENCES.....	6

LIST OF FIGURES

<u>Figure</u>	<u>Page</u>
II.1. Dimensions of main module configuration (cylinder) and proposed antenna locations 1, 2 and 3.....	7
II.2. Schematics of the long prolate spheroid used on graphics tablet system to simulate the main module.....	8
II.3. Long prolate spheroid. Side view.....	9
II.4. Long prolate spheroid. Front view.....	10
II.5. Long prolate spheroid. Top view.....	11
II.6. Mathematical model input data for main module.....	12
II.7. Simulation of main module. Side view.....	13
II.8. Simulation of main module. Front view.....	14
II.9. Simulation of main module. Top view.....	15
III.2-1. Dimensions of main module with two long solar panels.....	16
III.2-2. Mathematical model input data for main module with two long solar panels.....	17
III.2-3. Slot antenna on top of main module with two long solar panels. Side view.....	18

<u>Figure</u>	<u>Page</u>
III.2-4. Slot antenna on top of main module with two long solar panels. Front view.....	19
III.2-5. Slot antenna on top of main module with two-long solar panels. Top view.....	20
III.2-6. Mathematical model input data of main module. Antenna location 1.....	21
III.2-7. Antenna location 1 on the main module. Side view.....	22
III.2-8. Antenna location 1 on the main module. Front view.....	23
III.2-9. Antenna location 1 on the main module. Top view.....	24
III.2-10. Principal roll plane pattern at .2 GHZ. Axial slot antenna at location 1, without solar panels.....	25
III.2-11. Principal elevation plane pattern at .2 GHZ. Axial slot antenna at location 1, without solar panels.....	26
III.2-12. Principal roll plane pattern at 10 GHZ. Axial slot antenna at location 1, without solar panels.....	27
III.2-13. Principal elevation plane pattern at 10 GHZ. Axial slot antenna at location 1, without solar panels.....	28
III.2-14. Principal roll plane pattern at 30 GHZ. Axial slot antenna at location 1, without solar panels.....	29
III.2-15. Principal elevation plane pattern at 30 GHZ. Axial slot antenna at location 1, without-solar panels.....	30
III.2-16. Mathematical model input data of main module. Antenna location 2.....	31
III.2-17. Antenna location 2 on the main module. Side view.....	32
III.2-18. Antenna location 2 on the main module. Front view.....	33

<u>Figure</u>	<u>Page</u>
III.2-19. Antenna location 2 on the main module. Top view.....	34
III.2-20. Principal roll plane pattern at 1.6 GHZ. Axial slot antenna at location 2.....	35
III.2-21. Principal elevation plane pattern at 1.6 GHZ. Axial slot antenna at location 2.....	36
III.2-22. Mathematical model input data of main module. Antenna location 3.....	37
III.2-23. Antenna location 3 on the main module. Side view.....	38
III.2-24. Antenna location 3 on the main module. Front view.....	39
III.2-25. Antenna location 3 on the main module. Top view.....	40
III.2-26. Principal roll plane pattern at 1 GHZ. Axial slot antenna at location 3, with- out solar panels.....	41
III.2-27. Principal elevation plane pattern at 1 GHZ. Axial slot antenna at location 3, with- out solar panels.....	42
III.2.28. Mathematical model input data of main module without solar panels for multiple antennas.....	43
III.2.29. Axial slot antenna on top of main module without solar panels. Side view.....	44
III.2.30. Axial slot antenna on top of main module without solar panels. Front view.....	45
III.2.31. Axial slot antenna on top of main module without solar panels. Top view.....	46
III.2-32. Principal roll plane pattern at .26 GHZ. Axial slot antenna on top of main module without solar panels.....	47
III.2-33. Principal roll plane pattern at 2.2 GHZ. Axial slot antenna on top of main module without solar panels.....	48
III.2-34. Principal roll plane pattern at 25 GHZ. Axial slot antenna on top of main module without solar panels.....	49

<u>Figure</u>	<u>Page</u>
III.2-35. Two axial slot antennas on the top and the bottom of main module without solar panels. Side view.....	50
III.2-36. Two axial slot antennas on the top and the bottom of main module without solar panels. Front view.....	51
III.2-37. Two axial slot antennas on the top and the bottom of main module without solar panels. Top view.....	52
III.2-38. Principal roll plane pattern at .26 GHZ. Two axial slot antennas on the top and the bottom of main module without solar panels.....	53
III.2-39. Principal roll plane pattern at 2.2 GHZ. Two axial slot antennas on the top and the bottom of main module without solar panels.....	54
III.2-40. Principal roll plane pattern at 25 GHZ. Two axial slot antennas on the top and the bottom of main module without solar panels.....	55
III.2-41. Four axial slot antennas around main module without solar panels. Side view.....	56
III.2-42. Four axial slot antennas around main module without solar panels. Front views.....	57
III.2-43. Four axial slot antennas around main module without solar panels. Top views.....	58
III.2-44. Principal roll plane pattern at .26 GHZ. Four axial slot antennas around main module without solar panels.....	59
III.2-45. Principal roll plane pattern at 2.2 GHZ. Four axial slot antennas around main module without solar panels.....	60
III.2-46. Principal roll plane pattern at 25 GHZ. Four axial slot antennas around main module without solar panels.....	61
III.2-47. Mathematical model input data for main module with two long solar panels.....	62
III.2-48. Principal roll plane pattern at .26 GHZ. Axial slot antenna on top of main module with two long solar panels.....	63

<u>Figure</u>	<u>Page</u>
III.2-49. Principal roll plane pattern at 2.2 GHZ. Axial slot antenna on top of main module with two long solar panels.....	64
III.2-50. Principal roll plane pattern at 25 GHZ. Axial slot antenna on top of main module with two long solar panels.....	65
III.3-1. Design of second space station.....	66
III.3-2. Mathematical model input data for main module with two diagonal solar panels.....	67
III.3-3. Axial slot antenna on top of main module with two diagonal solar panels. Side view.....	68
III.3-4. Axial slot antenna on top of main module with two diagonal solar panels. Front view.....	69
III.3-5. Axial slot antenna on top of main module with two diagonal solar panels. Top view.....	70
III.3-6. Principal roll plane pattern at .26 GHZ. Axial slot antenna on top of main module with two diagonal solar panels.....	71
III.3-7. Principal roll plane pattern at 2.2 GHZ. Axial slot antenna on top of main module with two diagonal solar panels.....	72
III.3-8. Principal roll plane pattern at 25 GHZ. Axial slot antenna on top of main module with two diagonal solar panels.....	73
III.3-9. Origin of coordinate axis before and after translation.....	74
III.3-10. Coordinate axis before and after rotation around z-axis after translation of origin.....	75
III.3-11. Mathematical model input data for main module, two diagonal solar panels and bottom truss platform. Two axial slot antennas; one on top of the main module, the other on the right module.....	76
III.3-12. Axial slot antenna on top of the main module with two diagonal solar panels and bottom truss platform. Side view.....	77

<u>Figure</u>	<u>Page</u>
III.3-13. Axial slot antenna on top of the main module with two diagonal solar panels and bottom truss platform. Front view.....	78
III.3-14. Axial slot antenna on top of the main module with two diagonal solar panels and bottom truss platform. Top view.....	79
III.3-15. Principal roll plane pattern at .26 GHZ. Axial slot antenna on top of main module with two diagonal solar panels and bottom truss platform.....	80
III.3-16. Principal roll plane pattern at 2.2 GHZ. Axial slot antenna on top of main module with two diagonal solar panels and bottom truss platform.....	81
III.3-17. Principal roll plane pattern at 25 GHZ. Axial slot antenna on top of main module with two diagonal solar panels and bottom truss platform.....	82
III.3-18. Two axial slot antennas; one on top of the main module, the other on the right module, with two diagonal solar panels and bottom truss platform. Side view.....	83
III.3-19. Two axial slot antenna; one on top of the main module, the other on the right module, with two diagonal solar panels and bottom truss platform. Front view.....	84
III.3-20. Two axial slot antenna; one on top of the main module, the other on the right module, with two diagonal solar panels and bottom truss platform. Top view.....	85
III.3-21. Principal roll plane pattern at .26 GHZ. Two axial slot antennas; one on top of main module, the other on the right module.....	86
III.3-22. Principal roll plane pattern at 2.2 GHZ. Two axial slot antennas; one on top of main module, the other on the right module.....	87
III.3-23. Principal roll plane pattern at 25 GHZ. Two axial slot antennas; one on top of main module, the other on the right module.....	88

<u>Figure</u>	<u>Page</u>
III.3-24. Mathematical model input data for main module, two diagonal solar panels and bottom truss platform. Three axial slot antennas; one on each module.....	89
III.3-25. Three axial slot antennas on each module, with two diagonal solar panels and bottom truss platform. Side view.....	90
III.3-26. Three axial slot antennas on each module, with two diagonal solar panels and bottom truss platform. Front view.....	91
III.3-27. Three axial slot antennas on each module, with two diagonal solar panels and bottom truss platform. Top view.....	92
III.3-28. Principal roll plane pattern at .26 GHZ. Three axial slot antennas on top of each module.....	93
III.3-29. Principal roll plane pattern at 2.2 GHZ. Three axial slot antennas on top of each module.....	94
III.3-30. Principal roll plane pattern at 25 GHZ. Three axial slot antennas on top of each module.....	95

AIRBORNE ANTENNA PATTERN CALCULATIONS

By

Ali B. Bagherian¹, and Roland R. Mielke²

INTRODUCTION

The Program START has proven to be a powerful tool in computer generation of airborne antenna patterns for antennas mounted on the fuselage of general aviation aircraft. The calculation Program START produces airborne antenna radiation patterns that closely approximate the experimentally measured radiation patterns. See references (1-2). This approach has cost and time advantages over experimental measurement procedures for generating airborne antenna radiation patterns.

The Program START is currently being modified to produce radiation patterns for antennas mounted on space stations. The geometrical structure of the space station is more complex than general aviation aircraft and it demands more powerful calculation and modeling programs.

The proposed procedure to assemble the space station in the earth orbit is first to place the main module and two solar panels in synchronous orbit and then to add other parts by use of the space shuttle. Therefore, it is important to study the antenna radiation patterns at various degrees of completeness of the space station. That is, we first simulate the main module of the space station using the modeling Program P3D and study the radiation patterns of antennas mounted on the main module. Next, two plates are added to simulate two long solar panels and the above analysis is repeated. We then gradually add more plates to simulate other parts of the space station and calculate the resulting antenna patterns.

¹Graduate Research Assistant, Department of Electrical Engineering, Old Dominion University, Norfolk, Virginia 23508.

²Chairman and Associate Professor, Department of Electrical Engineering, Old Dominion University, Norfolk, Virginia 23508.

At present the modeling program P3D can handle one prolate spheroid to simulate the cylindrical configuration of the main module and a limited number of plates to simulate two solar panels and other parts. The calculation program START can accept one prolate spheroid and up to twenty-five plates to produce antenna radiation patterns. At this point there is a need to improve both the modeling and the calculation programs so that they can handle more than one prolate spheroid. There is also a need to increase the number of plates that both programs can accept.

To investigate the feasibility of using the existing modeling program P3D and calculation program START, a series of simulations of basic components of the space station are presented. The investigation includes axial slot antennas located on the main module of the space station.

A description and definition of input data required by Programs START and P3D are given in reference (2). The discussion of the use of interactive program P3D and an example of a modeling routine on the NASA/Langley Research Center computer system are also presented in reference (2).

II. SIMULATION OF MAIN MODULE

The main module is first simulated by a long prolate spheroid and then truncated at the appropriate location to obtain a cylinder which has nearly straight edges. The solar panels are simulated by two plates. These plates are either attached or not attached to the cylinder (main module) depending on the design of the space station.

The following frequency ranges are used for antenna radiation patterns: .2 GHZ, .25 GHZ, 1 GHZ, 1.6 GHZ, 2.2 GHZ, 10 GHZ, 25 GHZ and 30 GHZ. Figure

II.1. shows the dimensions of the main module and the proposed antenna locations. Figure II.2. shows the schematics of the long prolate spheroid used on the graphics tablet to simulate the main module. The side, front and top views of the simulated prolate spheroid are shown in figures II.3, II.4 and II.5. This prolate spheroid is truncated at $\pm 270'$ along the z-axis. The side, front and top views of the resulting cylinder with straight edge bases are shown in Figures II.7, II.8 and II.9.

III. TEST PATTERNS FOR PROPOSED SPACE STATIONS IN EARLY DESIGN STAGE

III.1 INTRODUCTION

Two proposed space stations in the early design stage are simulated in this section. The first simulation model consists of one main module and two long straight solar panels. The second simulation model has three modules, two diagonal solar panels and bottom truss platform.

For each preliminary design the model is simulated first and then radiation patterns for antennas mounted on the module are presented. Next the other parts of the space station are gradually added and then simulated.

III.2. Main Module With Two Long Solar Panels

The artist's conceptual drawing of the first space station with two long solar panels is shown in the next picture. As seen in this picture, the geometrical structure is complex. However, the components that most affect the antenna radiation patterns are the main module and two long solar panels. Simulation of these components of the space station is presented in this section.

The following simulation information concerning the dimensions of four corners of each long solar panel is easily obtained from dimensions of space

ORIGINAL PAGE
COLOR PHOTOGRAPH

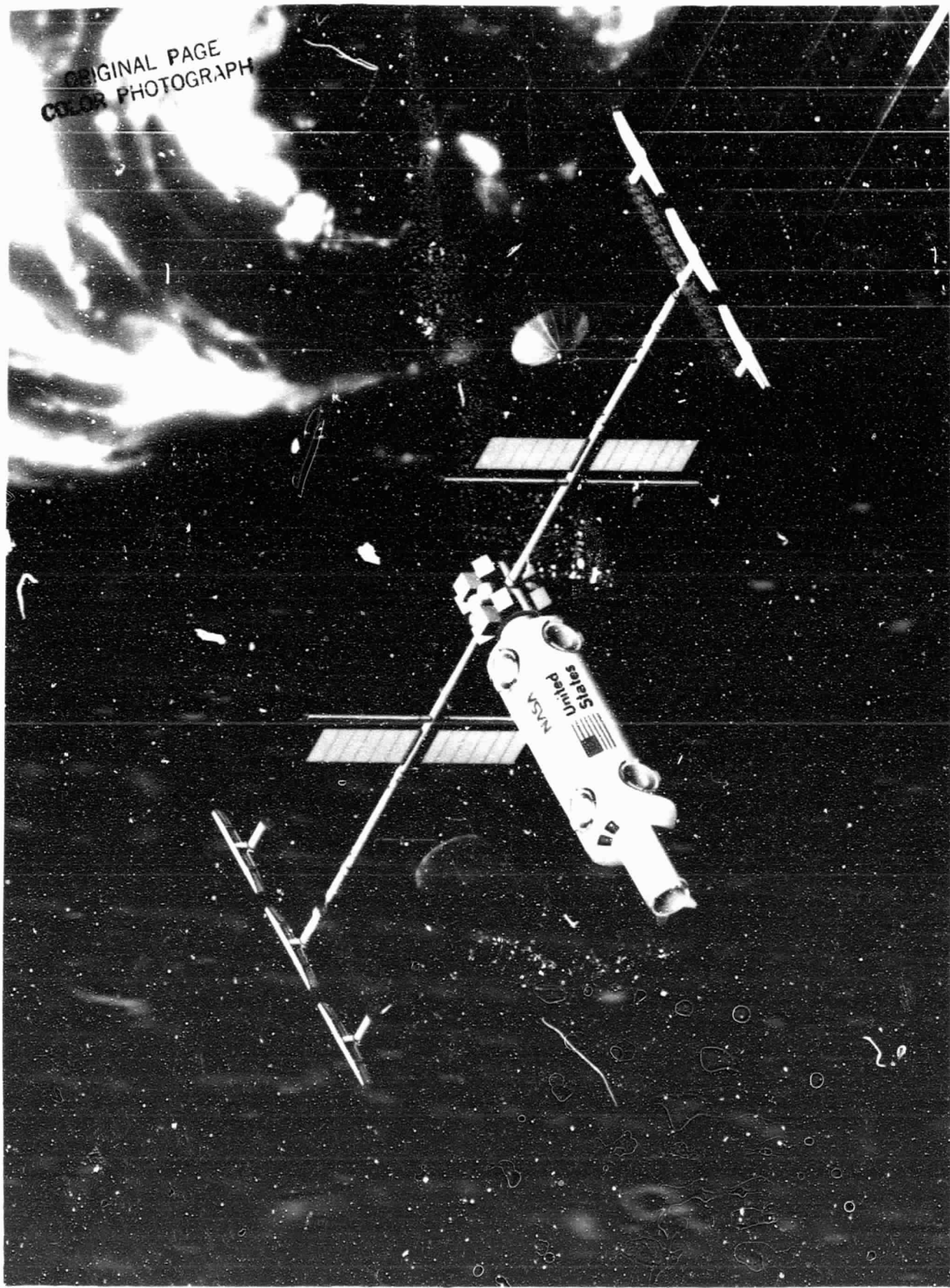

station shown in Figure III.2-1. This data is simply input as mathematical model input data manually as required by the "PG:" command:

PG: Left Solar Panel

4F

0.	720.	-360.
0.	4320	-360.
0.	4320.	360.
0.	720.	360.

PG: Right Solar Panel

4F

0.	-720.	360.
0.	-4320.	360.
0.	-4320.	-360.
0.	- 720.	-360.

these dimensions are in inches.

The modeling program simulates the main module completely when the long prolate spheroid is truncated out $\pm 270'$ along the z-axis. This is done by "FC:" command as follows:

FC:

T T

270. -270.

Figure III.2-1. shows the dimensions of the main module and two long solar panels. The side, front and top views of the simulation of the main module with solar panels are shown in Figures III.2-3., III.2-4 and III.2-5.

The principal roll plane patterns for axial slot antennas on the main

module with and without two long solar panels are presented in this section. Also, the principal roll plane patterns for axial slot antennas for the following multiple antenna locations are displayed:

one antenna on the top of main module, two antennas on the top and the bottom of main module and four antennas around the main module.

III.3 Three Modules With Two Diagonal Solar Panels and Bottom Truss Platform

Basic components of the second space station model shown in Figure III.3-1. are simulated in this section. The components that most affect antenna radiation patterns are modules, solar panels and platforms.

The coordinates of each corner of the diagonal solar panels and the bottom truss platform are easily obtained from the dimensions of the preliminary design of the space station shown in Figure III.3-1. This information is put in the mathematical model input data manually as required by the "PG:" command.

The principal roll plane patterns for an axial slot antenna on top of the main module with two diagonal solar panels are then presented. The simulation of the space station continues with the addition of the bottom truss platform. Then, two more modules are added by translation of the origin of the coordinate axis as shown in Figure III.3-9. using command "RT:" and rotation of the coordinate axis around the translated origin as seen in Figure III.3-10. using command "PD:". See reference (2) for explanations of commands "RT:" and "PD:". Note that geometrical structure is not rotated. Finally, principal roll plane patterns of axial slot antennas at various locations are presented.

REFERENCES

1. Bagherian, Ali B.; and Mielke, Roland R.: Airborne Antenna Pattern Calculations. Progress Report, NASA Research Grant NSG-1655, Aug. 1983.
2. Owens, Teri M.; Bagherian, Ali B.; and Mielke, Roland R.: Airborne Antenna Pattern Calculations. Final Report, NASA Research Grant NSG-1655, Dec. 1982.

ORIGINAL PAGE IS
OF POOR QUALITY

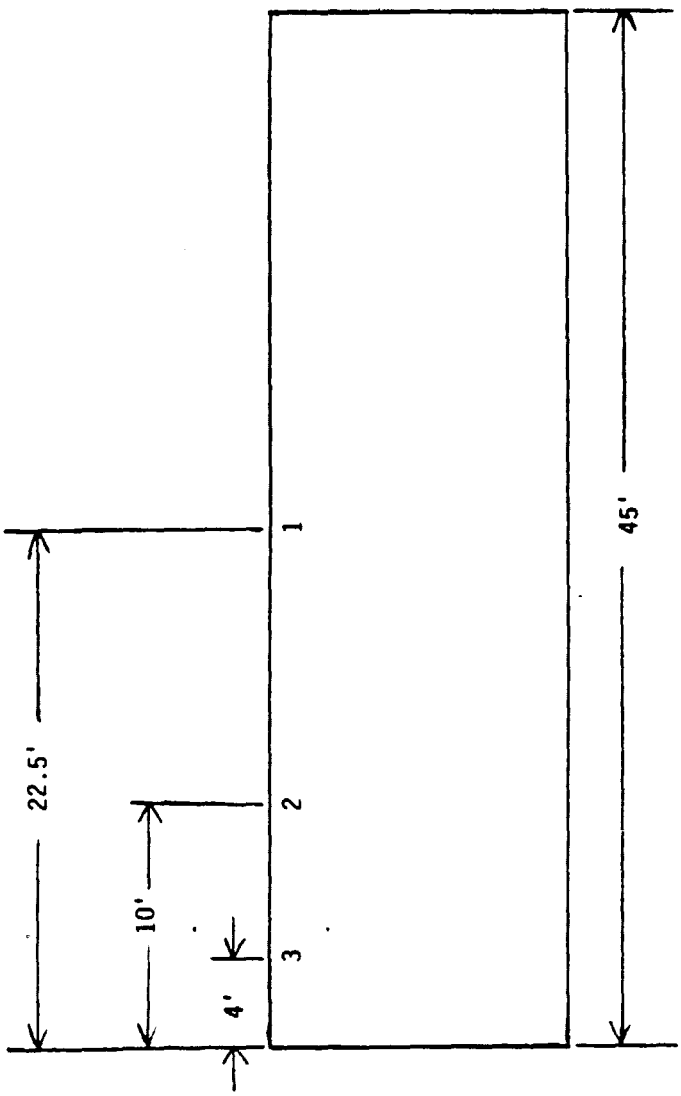

Side View

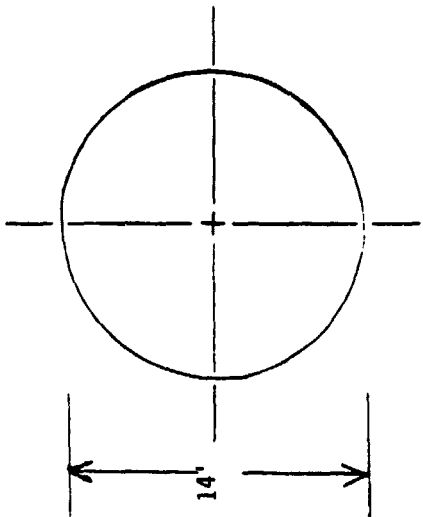

End View

Figure II.1. Dimensions of main module configuration (cylinder) and proposed antenna locations 1, 2 and 3.

Scale Factor = 288

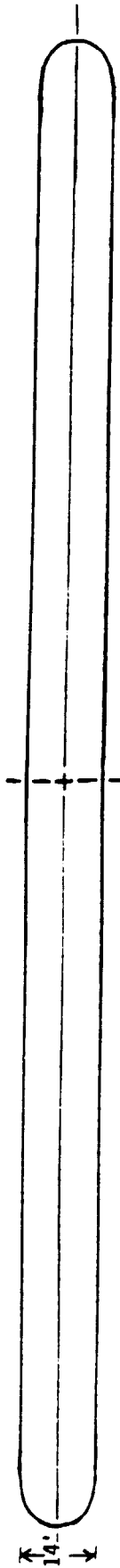

ORIGINAL PAGE IS
OF POOR QUALITY

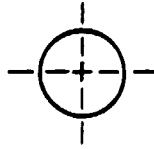

Figure II.2. Schematics of the long prolate spheroid used on graphics tablet system to simulate the main module.

ORIGINAL PAGE IS
OF POOR QUALITY

LONG PROLATE SPHEROID TO SIMULATE THE MAIN MODULE.
FUSELAGE PROFILE
(ELEVATION PLANE)



S. F. = 289.000

Figure II.3. Long prolate spheroid. Side view.

ORIGINAL PAGE IS
OF POOR QUALITY

LONG PROLATE SPHEROID TO SIMULATE THE MAIN MODULE.
CROSS SECTION
(ROLL PLANE)



S. F. = 288.000

Figure II.4. Long prolate spheroid. Front view.

ORIGINAL PAGE IS
OF POOR QUALITY

LONG PROLATE SPHEROID TO SIMULATE THE MAIN MODULE.
HEADING PROFILE
(AZIMUTH PLANE)



$S. F. = 288.000$

Figure II.5. Long prolate spheroid. Top view.

ORIGINAL PAGE IS
OF POOR QUALITY

```
FG.  
 84.0 1763.5 1763.5  
 0. 0. 0.  
FC:  
 T T  
 270.0 -270.0  
EX:  
END OF FILE  
?? E  
SLTU1 IS A LOCAL FILE  
/
```

Figure II.6. Mathematical model input data for main module.

ORIGINAL PAGE 13
OF POOR QUALITY

SIMULATED MAIN MODULE
FUSelage PROFILE
(ELEVATION PLANE)

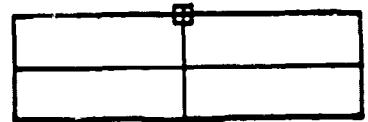

S. F. = 288.000

Figure II.7. Simulation of main module. Side view.

ORIGINAL PAGE IS
OF POOR QUALITY

SIMULATED MAIN MODULE
CROSS SECTION
(ROLL PLANE)



S. F. = 200.000

Figure II.8. Simulation of main module. Front view.

ORIGINAL PAGE 13
OF POOR QUALITY

SIMULATED MAIN MODULE
HEADING PROFILE
(AZIMUTH PLANE)



S. F. = 288.000

Figure II.9. Simulation of main module. Top view.

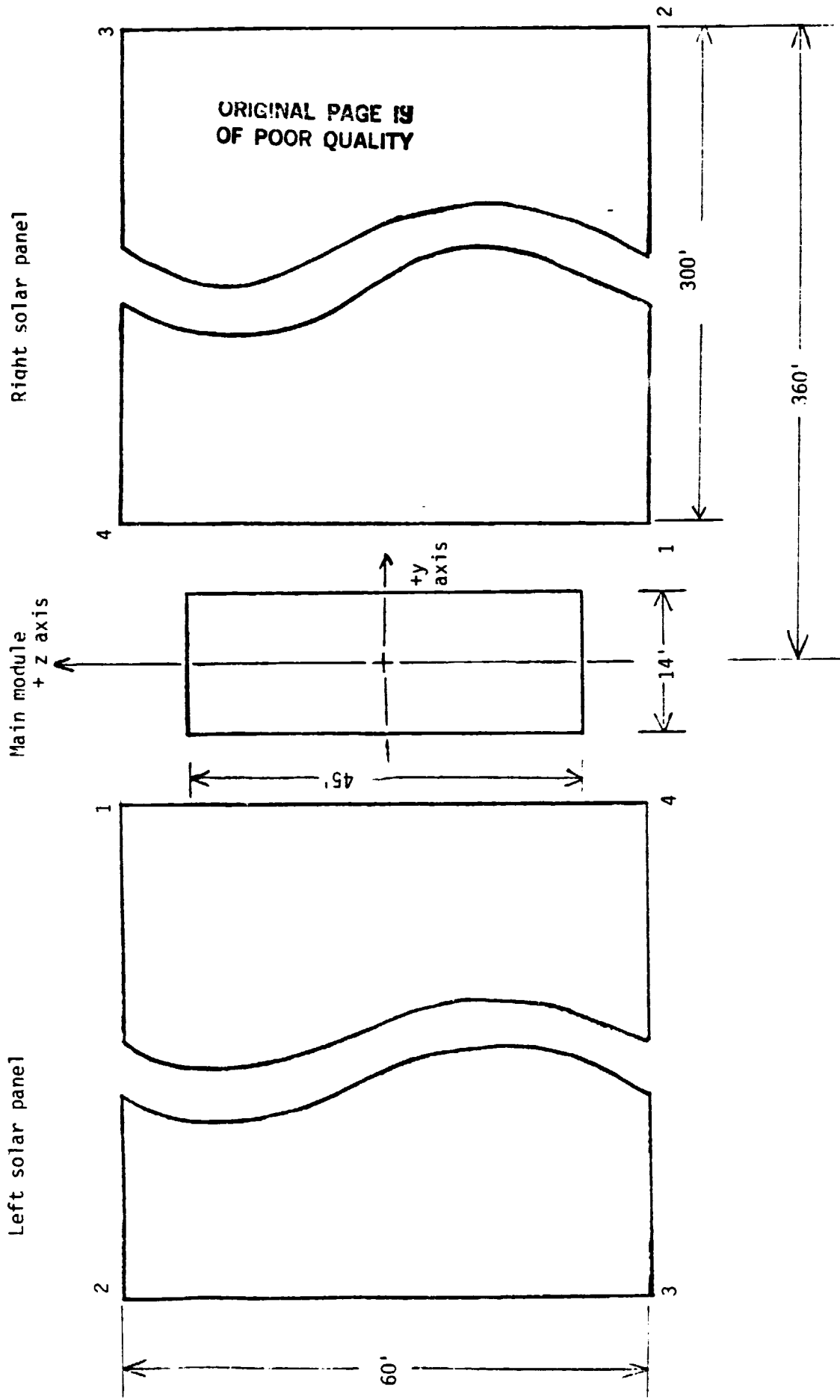

Figure III.2-1. Dimensions of main module with two long solar panels.

ORIGINAL PAGE IS
OF POOR QUALITY

```
FG MAIN MODULE WITH SOLAR PANELS.
84.0 1763 5 1763 5
. . .
FC
T T
270 0 -270 0
PG LEFT SOLAR PANEL
4 F
. 720 -360
. 4320 -360
. 4320 360
. 720 360
PG RIGHT SOLAR PANEL
4 F
. -720 360
. -4320 360
. -4320 -360
. -720 -360
SG
. .
1
. .
.01 .5 0. 0 1
1. 0
FO 26 GHZ
1 26 1
PP
3.75 3
PD ROLL PLANE
. 90
90 91 2
. 360 1
T 50000
F 3

EX
FO 2.2 GHZ
1 2.2 1
EX
FO 25 GHZ
1 25 1
EX
END OF FILE
??
```

Figure III.2-2. Mathematical model input data for main module with two long solar panels.

ORIGINAL PAGE IS
OF POOR QUALITY

SPACE STATION WITH TWO LONG SOLAR PANELS.
FUSelage PROFILE
(ELEVATION PLANE)



S. F. = 288.000

Figure III.2-3. Slot antenna on top of main module with two long solar panels. Side view.

ORIGINAL PAGE 19
OF POOR QUALITY

SPACE STATION WITH TWO LONG SOLAR PANELS.
CROSS SECTION
(ROLL PLANE)



S. F. = 200.000

Figure III.2-4. Slot antenna on top of main module with two long solar panels. Front view.

ORIGINAL PAGE IS
OF POOR QUALITY

SPACE STATION WITH TWO LONG SOLAR PANELS.
HEADING PROFILE
(AZIMUTH PLANE)

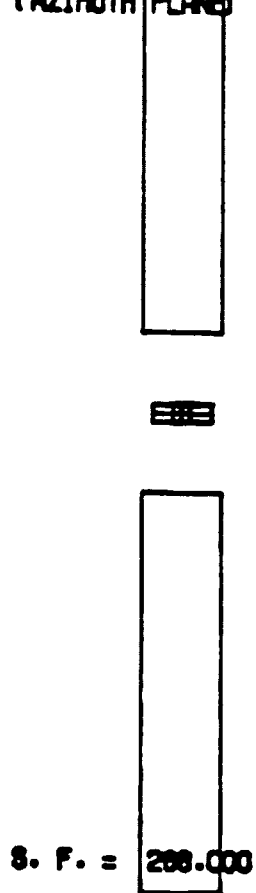

Figure III.2-5. Slot antenna on top of main module with two long solar panels. Top view.

ORIGINAL PAGE 19
OF POOR QUALITY

```

FG
 84 0 1763 5 1763 5
 0 0 0
PP
 3 75 3
FC
 T T
270 0 -270 0
SG
 0 0
 1
 0 0
 01 5 0 0 1
 1 0
FO: 2 GHZ
 1 2 1
PD: ROLL PLANE
 0 90
 90 91 2
 0 360 1
 T 50000
 F 3
EX:
PD: ELEVATION PLANE
 90 90
 90 91 2
 0 360 1
 T 50000
 F 3
EX:
FO: 10 GHZ
 1 10 1
PD: ROLL PLANE
 0 90

```

```

90 91 2
 0 360 1
 T 50000
 F 3
EX:
PD: ELEVATION PLANE
 90 90
 90 91 2
 0 360 1
 T 50000
 F 3
EX:
FO: 30 GHZ
 1 30 1
PD: ROLL PLANE
 0 90
 90 91 2
 0 360 1
 T 50000
 F 3
EX:
PD: ELEVATION PLANE
 90 90
 90 91 2
 0 360 1
 T 50000
 F 3
EX:
END OF FILE
?? E.,RL
SS123 REPLACED
SS123 IS A LOCAL FILE
/

```

Figure III.2-6. Mathematical model input data of main module.
Antenna location 1.

ORIGINAL PAGE 10
OF POOR QUALITY

SIMULATION OF MAIN MODULE.
FUSelage PROFILE
(ELEVATION PLANE)



S. F. = 288.000

Figure III.2-7. Antenna location 1 on the main module.
Side view.

ORIGINAL PAGE IS
OF POOR QUALITY

SIMULATION OF MAIN MODULE.
CROSS SECTION
(ROLL PLANE)



S. F. = 288.000

Figure III.2-8. Antenna location 1 on the main module. Front view.

ORIGINAL PAGE IS
OF POOR QUALITY

SIMULATION OF MAIN MODULE.
HEADING PROFILE
(AZIMUTH PLANE)

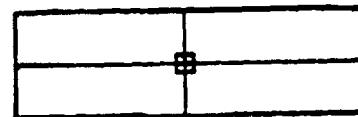

S. F. = 288.000

Figure III.2-9. Antenna location 1 on the main module. Top view.

ORIGINAL PAGE IS
OF POOR QUALITY

E--PHI
DB PLOT

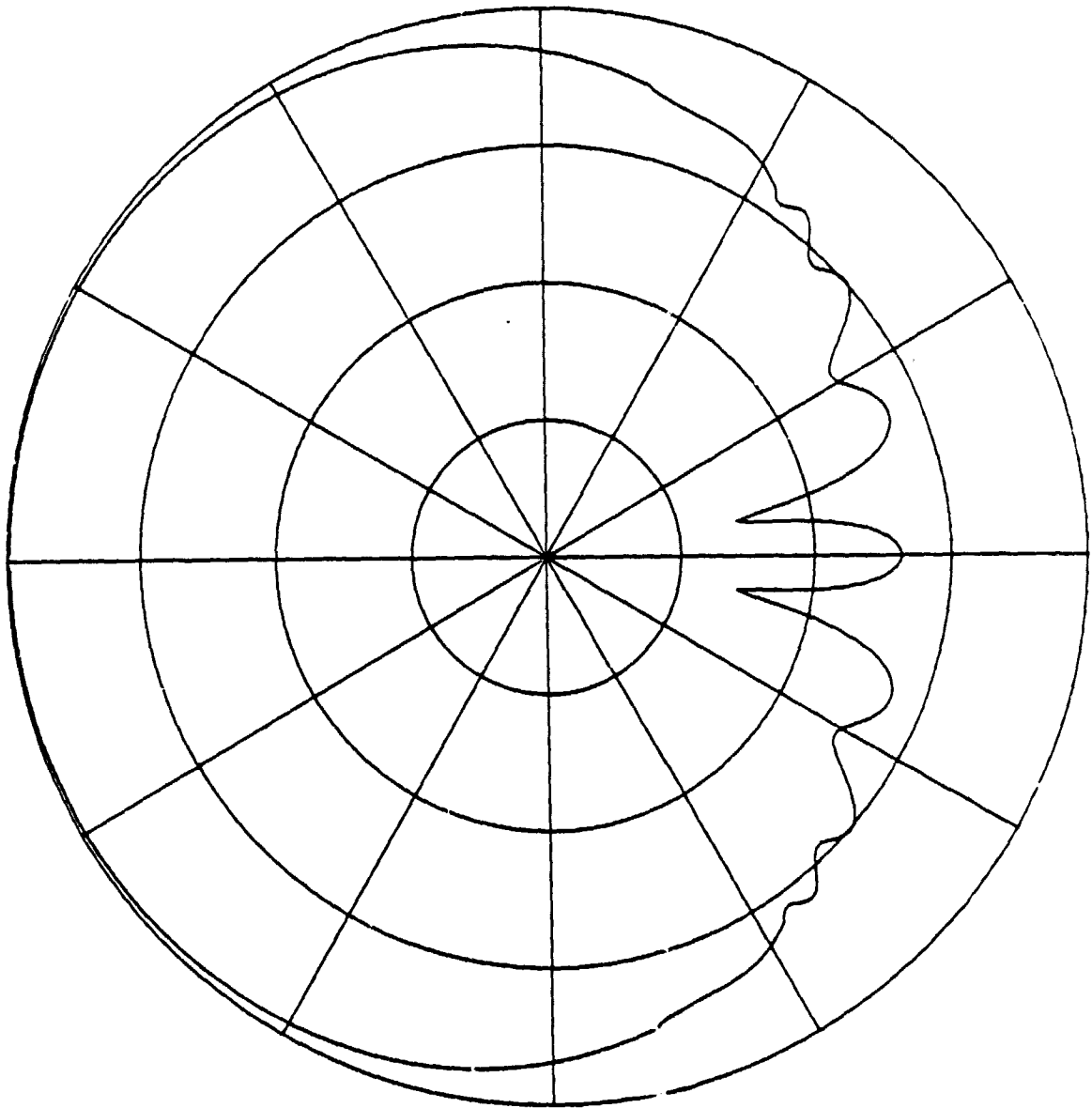

Figure III.2-10. Principal roll plane pattern at .2 GHZ. Axial slot antenna at location 1, without solar panels.

ORIGINAL PAGE IS
OF POOR QUALITY

E-THETA
DB PLOT

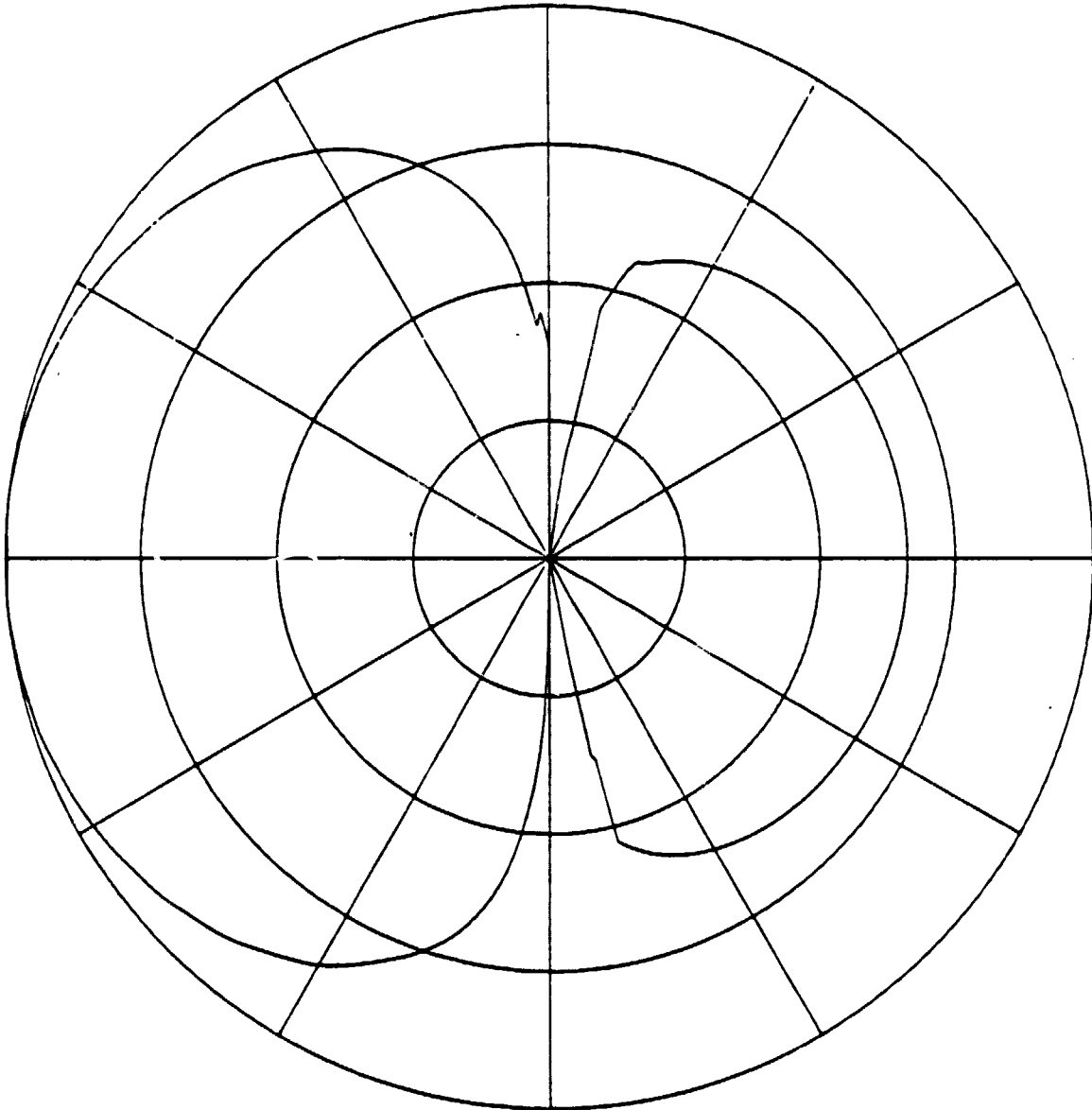

Figure III.2-11. Principal elevation plane pattern at .2 GHZ.
Axial slot antenna at location 1, without
solar panels.

ORIGINAL PAGE IS
OF POOR QUALITY

E-PHI
DB PLOT

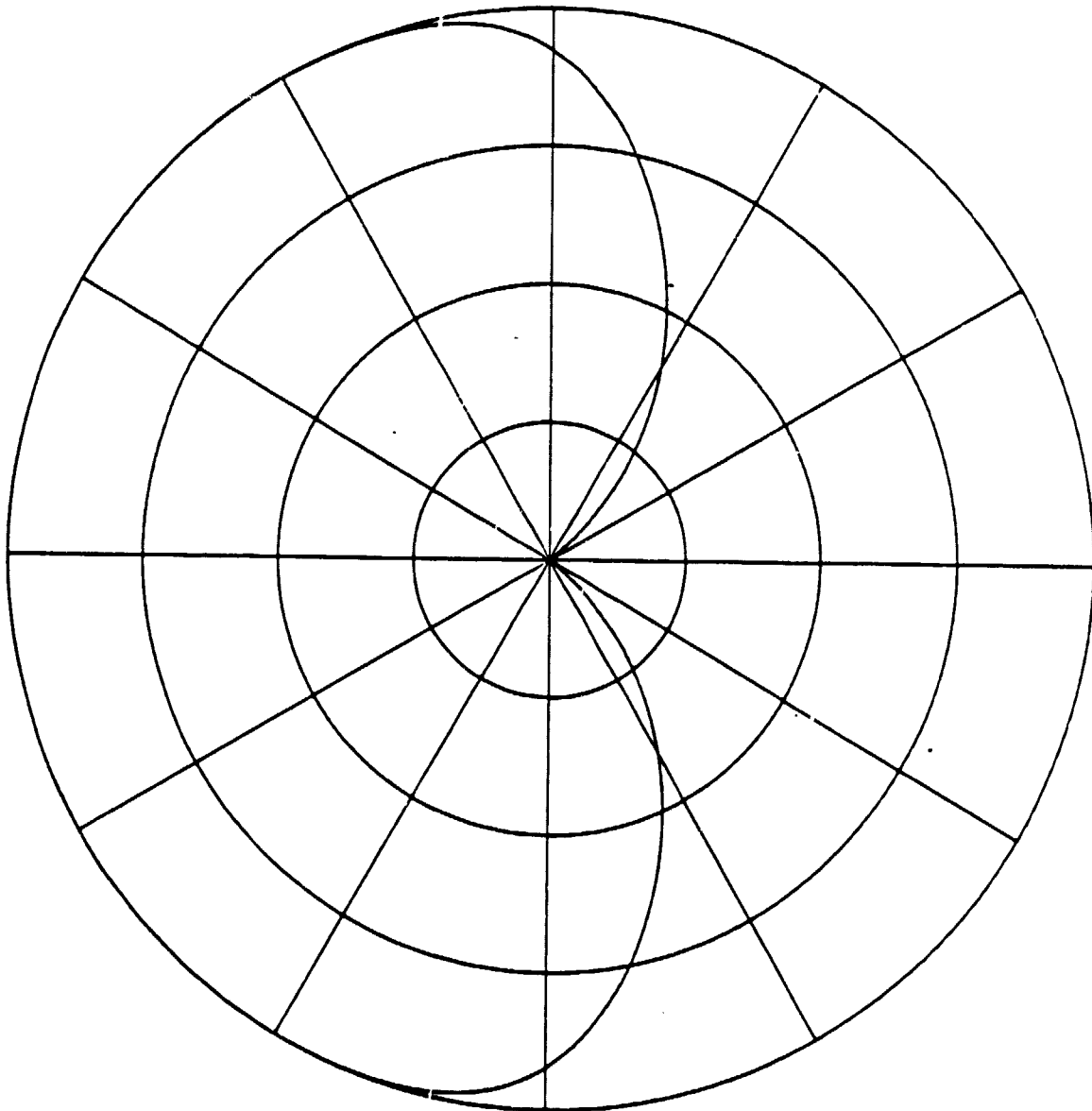

Figure III.2-12. Principal roll plane pattern at 10 GHz.
Axial slot antenna at location 1, without
solar panels.

ORIGINAL PAGE 19
OF POOR QUALITY

E-THETA
DB PLOT

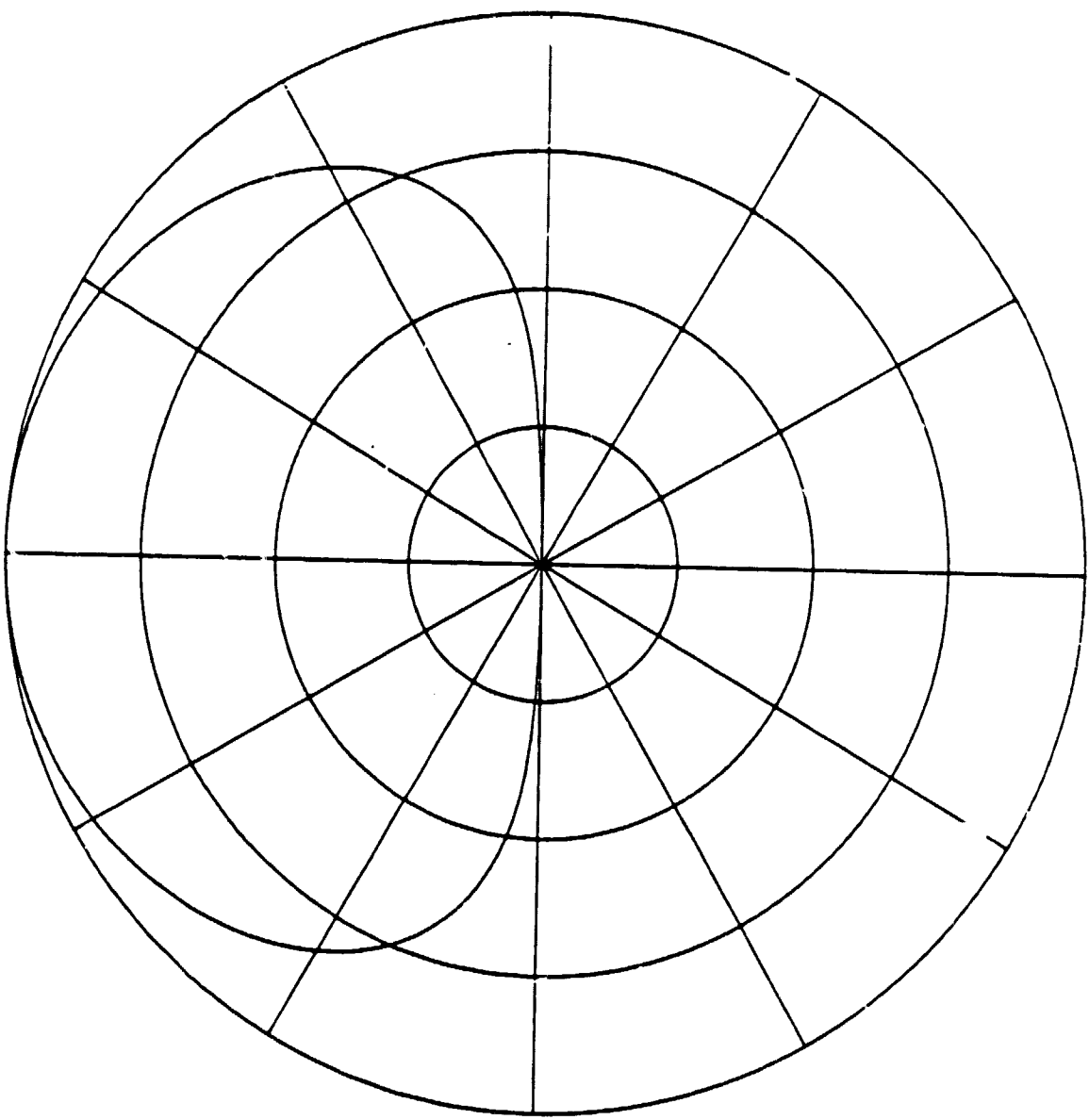

Figure III.2-13. Principal elevation plane pattern at 10 CHZ.
Axial slot antenna at location 1, without solar
panels.

ORIGINAL PATTERN
OF POOR QUALITY

E-PHI
DB PLOT

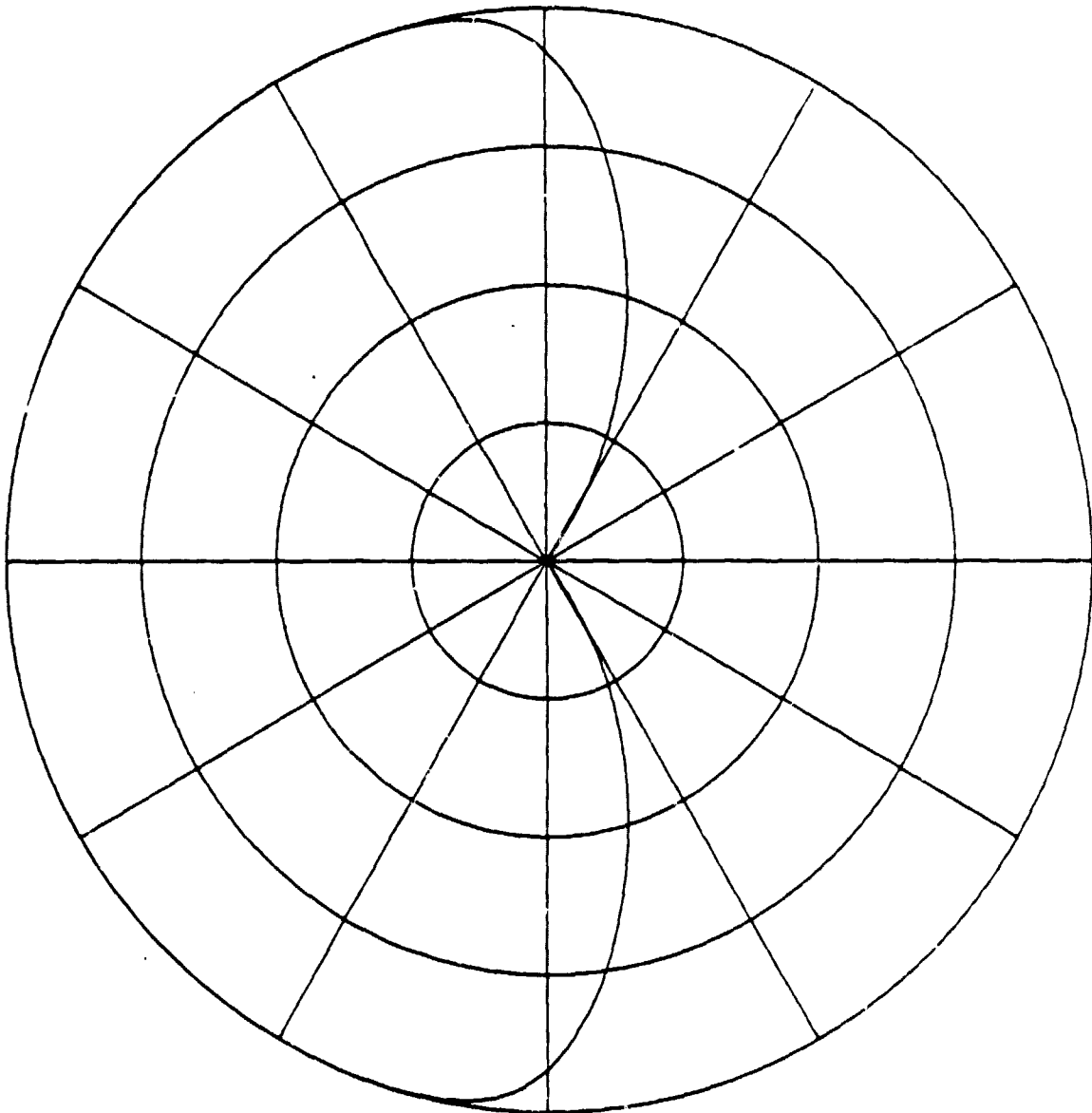

Figure III.2-14. Principal roll plane pattern at 30 GHz.
Axial slot antenna at location-1,
without solar panels.

E-THETA
DB PLOT

ORIGINAL PAGE 19
OF POOR QUALITY

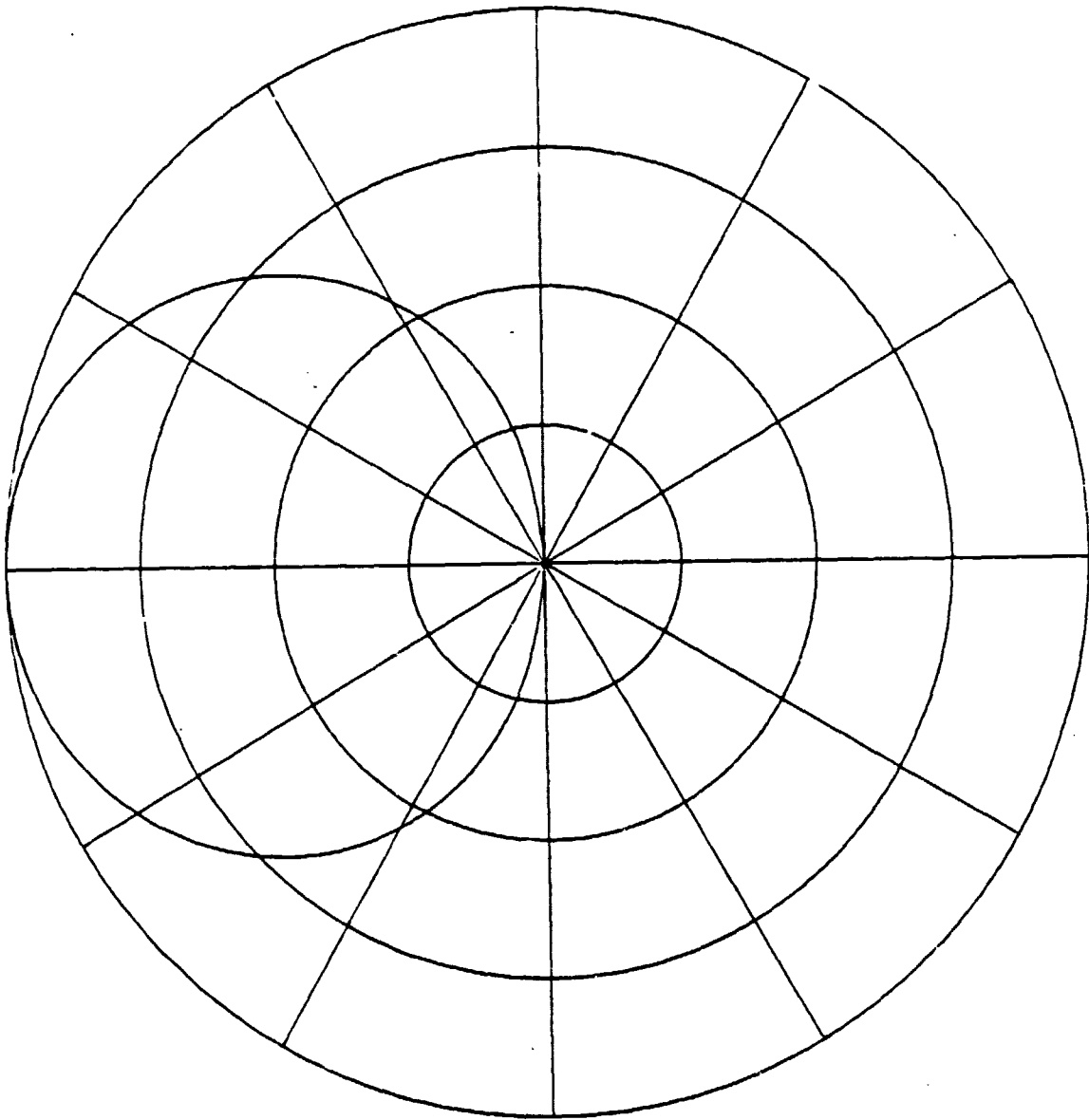

Figure III.2-15. Principal elevation plane pattern at 30 GHz.
Axial slot antenna at location 1, without
solar panels.

ORIGINAL PAGE IS
OF POOR QUALITY

```
FG:
84.0 1763 5 1763.5
0.0 0.
PP:
3.75 3
FC:
T T
270 0 -270 0
SG:
0. -150.
1
0. 0.
.01 .5 0 0. 1
1. 0.
FQ: 1.6 GHZ
1 1.6 1
PD:
0. 90.
90 91 2
0 360 1
T 50000
F 3
EX:
PD:
90. 90.
90 91 2
0 360 1
T 50000
F 3
EX:
END OF FILE
?? E
$$123 IS A LOCAL FILE
/
```

Figure III.2-16. Mathematical model input data of main module.
Antenna location 2.

ORIGINAL PAGE IS
OF POOR QUALITY

SIMULATION OF MAIN MODULE.
FUSelage PROFILE
(ELEVATION PLANE)



S. F. = 298.000

Figure III.2-17. Antenna location 2 on the main module. Side view.

ORIGINAL PAGE IS
OF POOR QUALITY

SIMULATION OF MAIN MODULE.
CROSS SECTION
(ROLL PLANE)



S. F. = 200.000

Figure III.2-18. Antenna location 2 on the main module.
Front view.

ORIGINAL PAGE IS
OF POOR QUALITY

SIMULATION OF MAIN MODULE.
HEADING PROFILE
(AZIMUTH PLANE)



S. F. = 200.000

Figure III.2-19. Antenna location 2 on the main module. -
Top view.

ORIGINAL PAGE IS
OF POOR QUALITY

E-PHI
DB PLOT

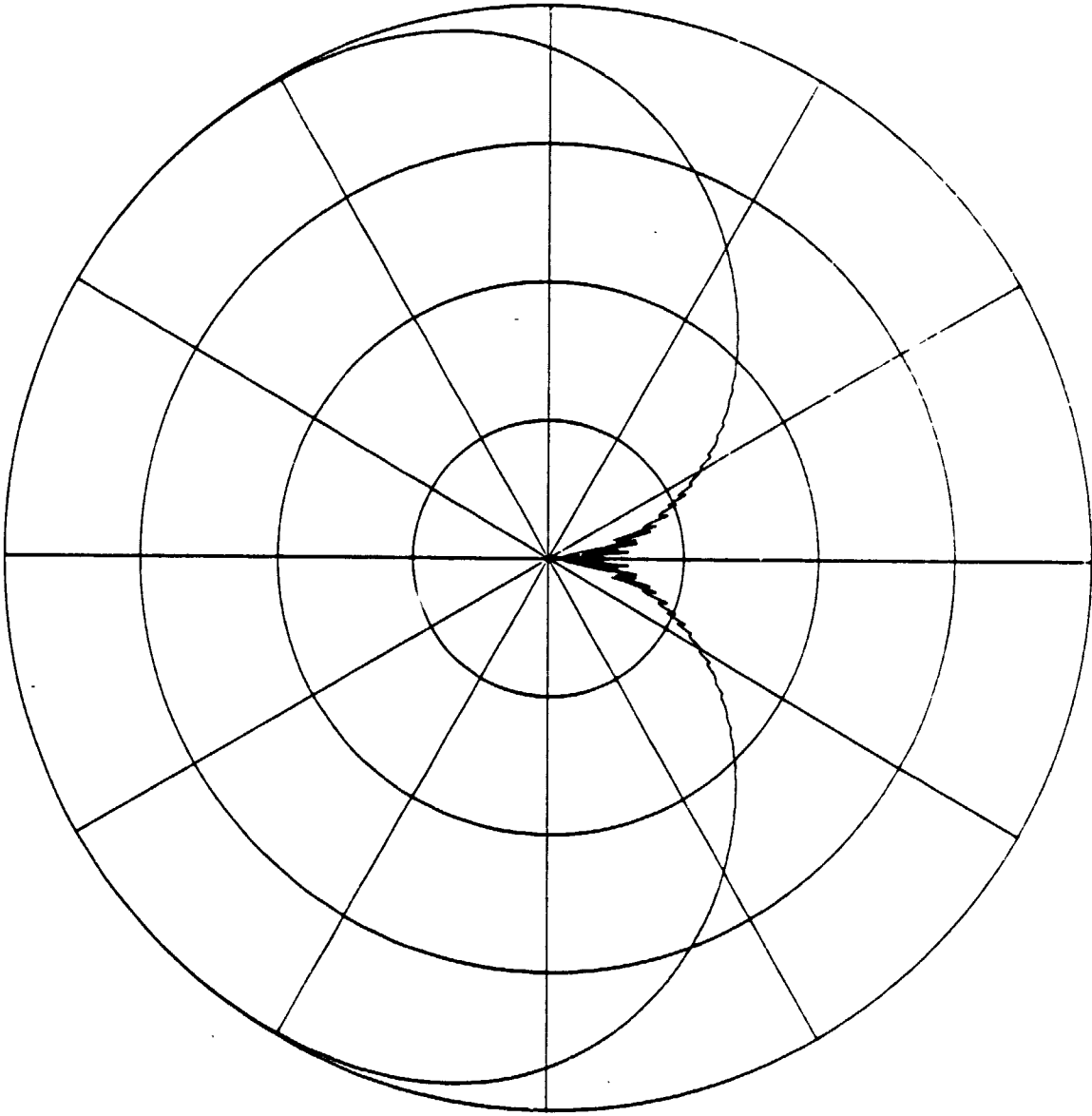

Figure III.2-20. Principal roll plane pattern at 1.6 GHz.
Axial slot antenna at location 2.

ORIGINAL PAGE IS
OF POOR QUALITY

E-THETA
DB PLOT

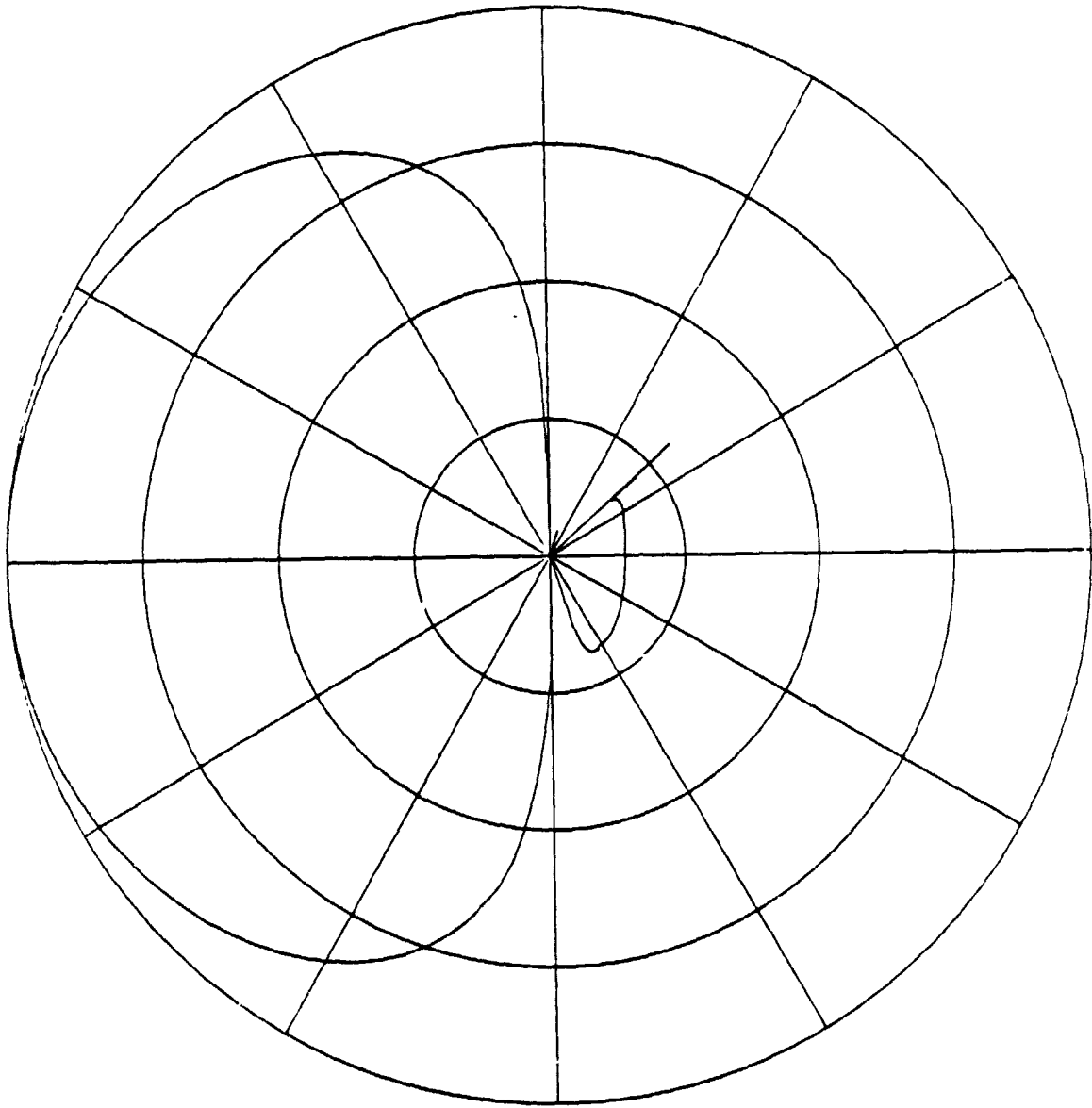

Figure III.2-21. Principal elevation plane pattern at 1.6 GHz.
Axial slot antenna at location 2.

ORIGINAL PAGE IS
OF POOR QUALITY

```
FG:
84 0 1763 5 1763 5
0 0 0
PP:
3 75 3
FC:
T T
270 0 -270 0
SG:
0 -222
1
0 0
01 5 0 0 1
1 0
FO: 1 GHZ
1 1 1
PD: ROLL PLANE
0 90
90 91 2
0 360 1
T 50000
F 3
EX:
PD: ELEVATION PLANE
90 90
90 91 2
0 360 1
T 50000
F 3
EX:
END OF FILE
?? E
SS123 IS A LOCAL FILE
/
```

Figure III.2-22. Mathematical model input data of main module.
Antenna location 3.

ORIGINAL PAGE IS
OF POOR QUALITY

SIMULATION OF MAIN MODULE.
FUSELAGE PROFILE
(ELEVATION PLANE)



S. F. = 200.000

Figure III.2-23. Antenna location 3 on the main module. Side view.

ORIGINAL PAGE 19
OF POOR QUALITY

SIMULATION OF MAIN MODULE.
FUSELAGE PROFILE
(ELEVATION PLANE)



S. F. = 288.000

Figure III.2-24. Antenna location 3 on the main module.
Front view.

ORIGINAL PAGE IS
OF POOR QUALITY

SIMULATION OF MAIN MODULE.
MEADING PROFILE
(AZIMUTH PLANE)



S. F. = 288.000

Figure III.2-25. Antenna location 3 on the main module.
Top view.

ORIGINAL PAGE IS
OF POOR QUALITY

E-PHI
DB PLOT

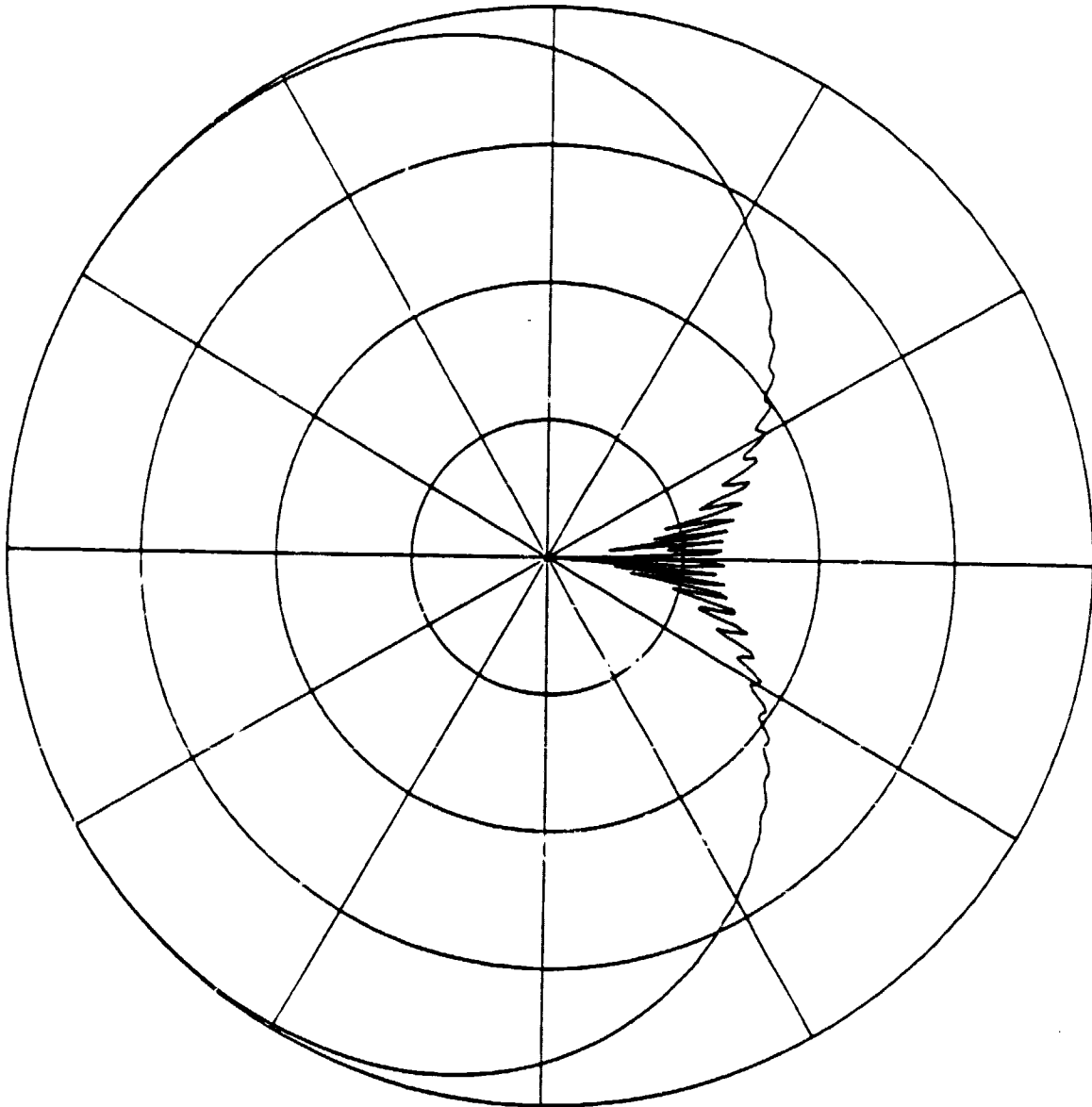

Figure III.2-26. Principal roll plane pattern at 1 GHZ. Axial slot antenna at location 3, without solar panels.

ORIGINAL PAGE IS
OF POOR QUALITY

E-THETA
DB PLOT

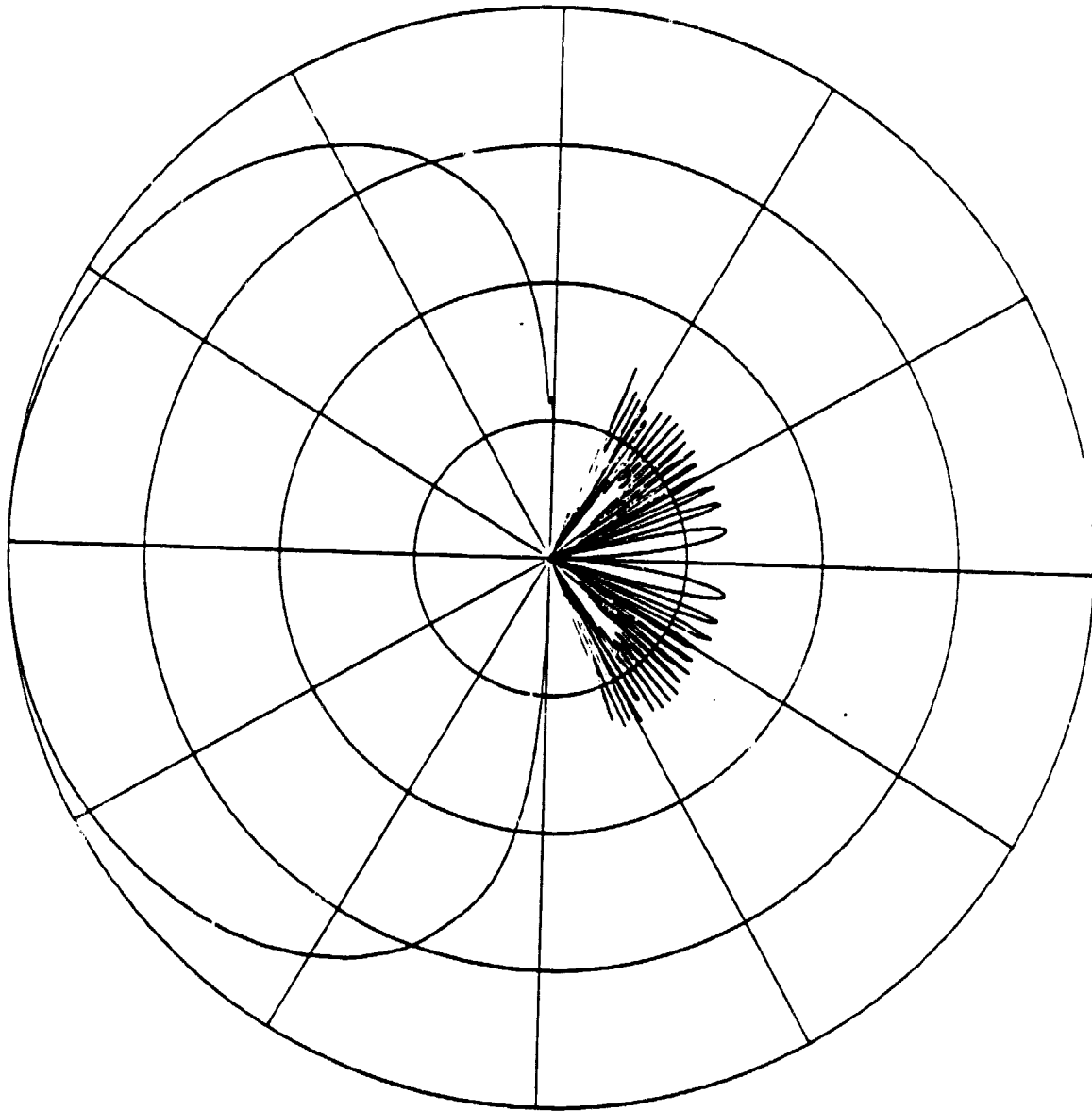

Figure III.2-27. Principal elevation plane pattern at 1 GHz. Axial slot antenna at location 3, without solar panels.

ORIGINAL PAGE IS
OF POOR QUALITY

```
1
FG MAIN MODULE WITHOUT SOLAR PANELS. 0. 0.
84 0 1763 S 1763.5 .01 5 0. 0. 1
0. 0. 0. 1. 0.
PP. EX:
3.75 3 PD:
FC. 0. 0.
T T 90 91 2
270 0 -270 0 0 360 1
SQ: T 50000
0 0 F 3
1 EX:
0 0 END OF FILE
.01 5 0. 0 1 ?? E
1 SLTV1 IS A LOCAL FILE
FG 26 GHZ /
1 26 1
PD:
0. 1
90 91 2
0 360 1
T 50000
F 3
EX:
SP:
T 1 0
PD:
0. 179 8
90 91 2
0 360 1
T 50000
F 3
EX:
SQ:
90. 0.
```

Figure III.2-28. Mathematical model input data of main module without solar panels for multiple antennas.

ORIGINAL PAGE IS
OF POOR QUALITY

MAIN MODULE OF SPACE STATION.
FUSelage PROFILE
(ELEVATION PLANE)



S. F. = 288.000

Figure III.2-29. Axial slot antenna on top of main module without solar panels. Side view.

ORIGINAL PAGE IS
OF POOR QUALITY

MAIN MODULE OF SPACE STATION.
CROSS SECTION



Figure III.2-30. Axial slot antenna on top of main module without solar panels. Front view.

ORIGINAL PAGE IS
OF POOR QUALITY

MAIN MODULE OF SPACE STATION.
HEADING PROFILE
(AZIMUTH PLANE)

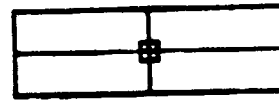

S. F. = 288.000

Figure III.2-31. Axial slot antenna on top of main module without solar panels. Top view.

ORIGINAL PAGE IS
OF POOR QUALITY

E-PHI
DB PLOT

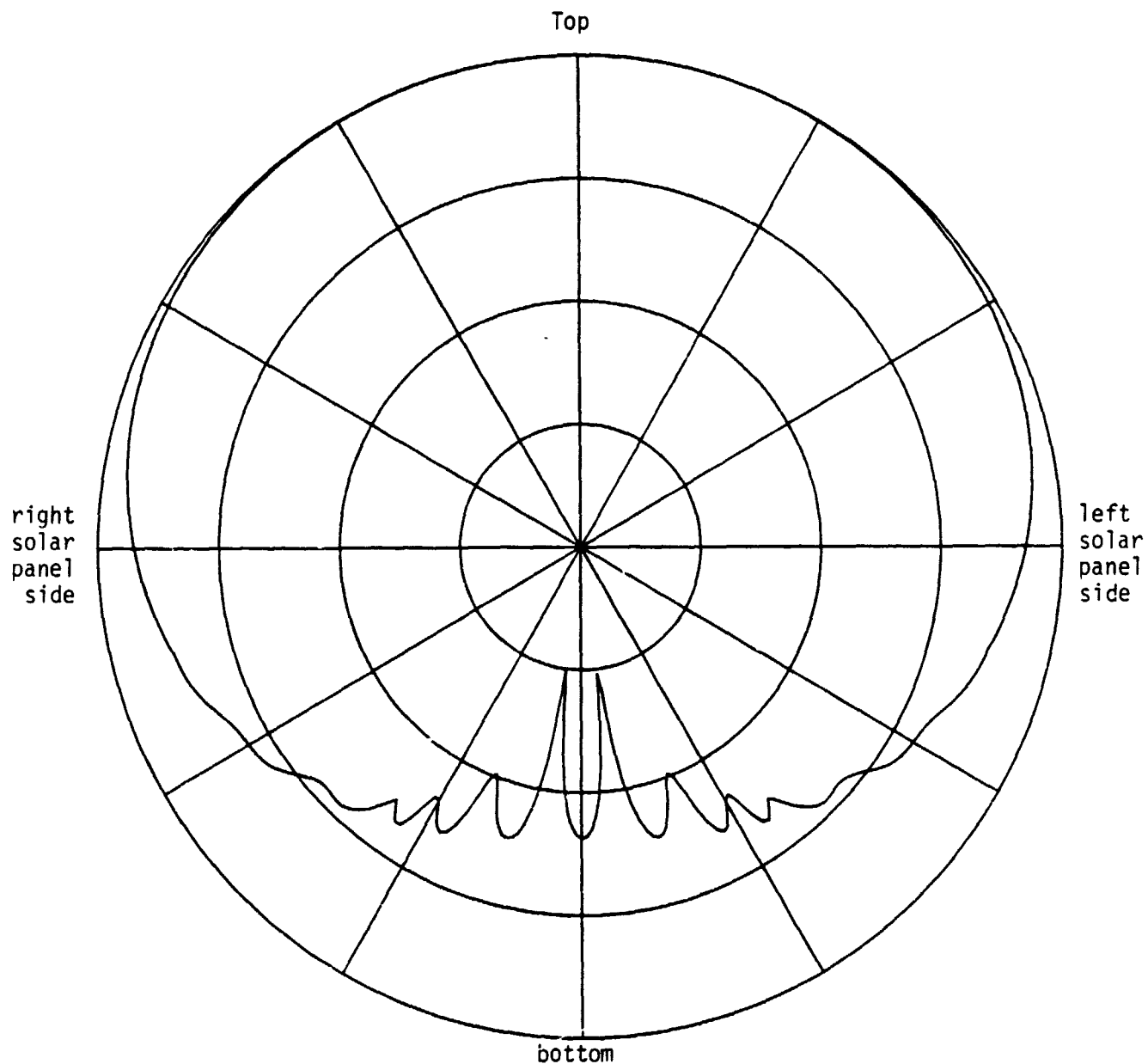

Figure III.2-32. Principal roll plane pattern at .26 GHZ.
Axial slot antenna on top of main module
without solar panels.

ORIGINAL PAGE 19
OF POOR QUALITY

E-PHI
DB PLOT

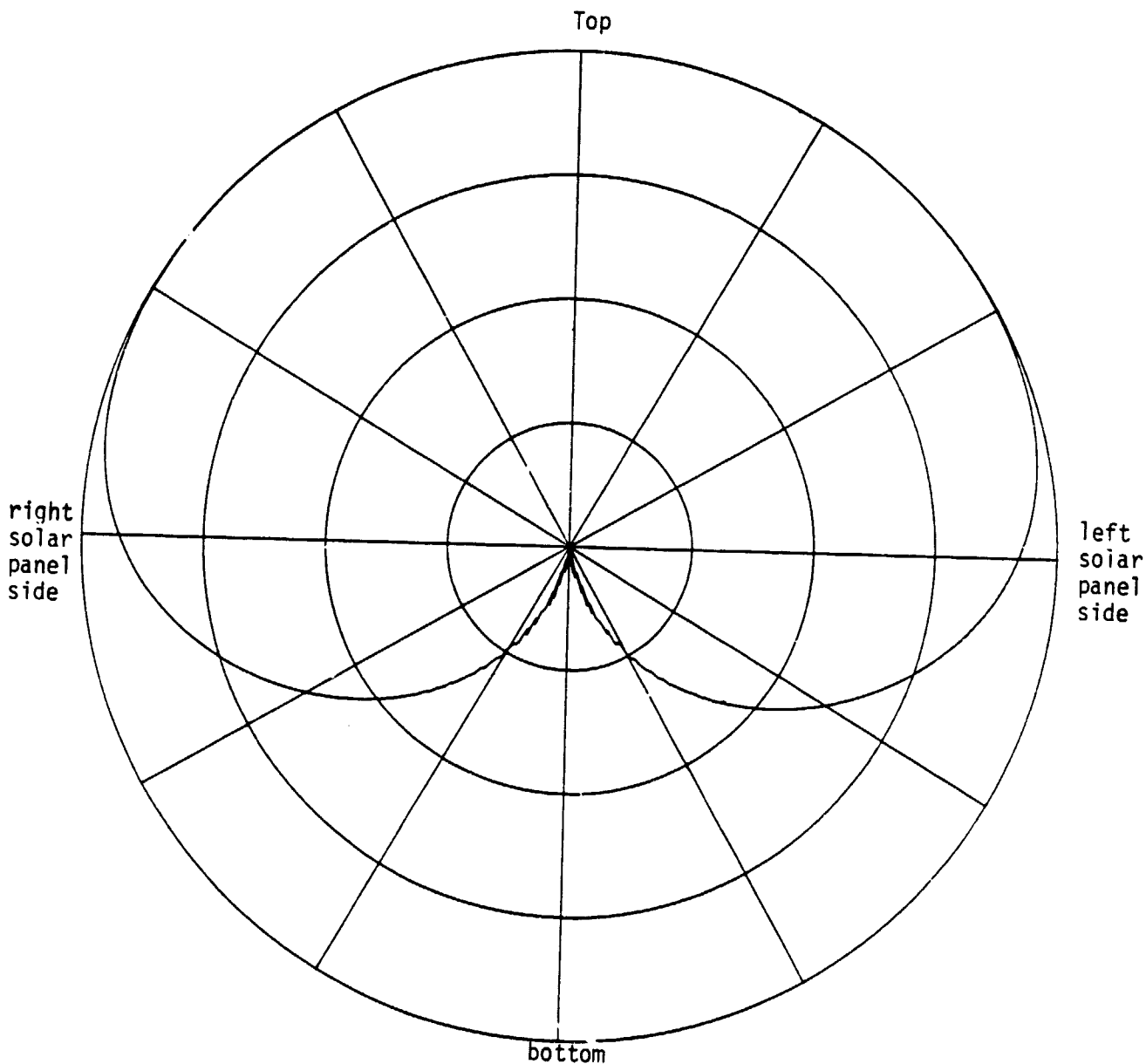

Figure III.2-33. Principal roll plane pattern at 2.2 GHz. Axial slot antenna on top of main module without solar panels.

ORIGINAL PAGE IS
OF POOR QUALITY

E-PHI
DB PLOT

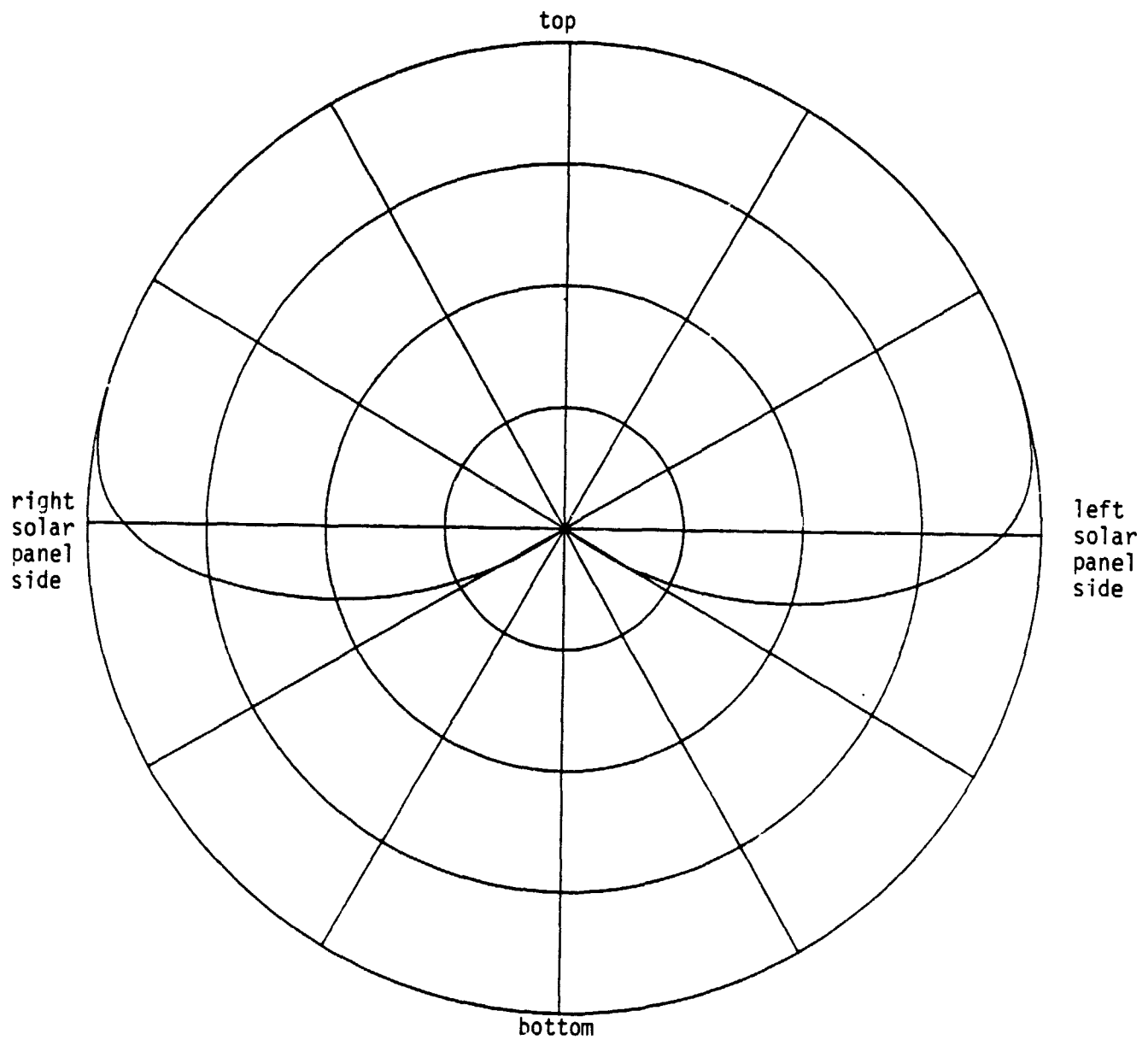
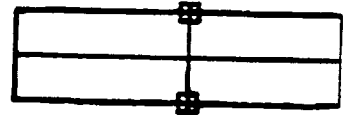

Figure III.2-34. Principal roll plane pattern at 25 GHz.
Axial slot antenna on top of main module
without solar panels.

ORIGINAL PAGE IS
OF POOR QUALITY

MAIN MODULE OF THE SPACE STATION.
FUELAGE PROFILE
(ELEVATION PLANE)



S. F. = 228.000

Figure III.2-35. Two axial slot antennas on the top and the bottom of main module without solar panels. Side view.

ORIGINAL PAGE IS
OF POOR QUALITY

MAIN MODULE OF THE SPACE STATION.
CROSS SECTION
(ROLL PLANE)



S. F. = 200.000

Figure III.2-36. Two axial slot antennas on the top and the bottom of main module without solar panels. Front view.

ORIGINAL PAGE 19
OF POOR QUALITY

MAIN MODULE OF THE SPACE STATION.
MEASURING PROFILE
(AZIMUTH PLANE)



S. F. = 288.000

Figure III.2-37. Two axial slot antennas on the top and the bottom of main module without solar panels. Top view.

ORIGINAL PAGE IS
OF POOR QUALITY

E-PHI
DB PLOT

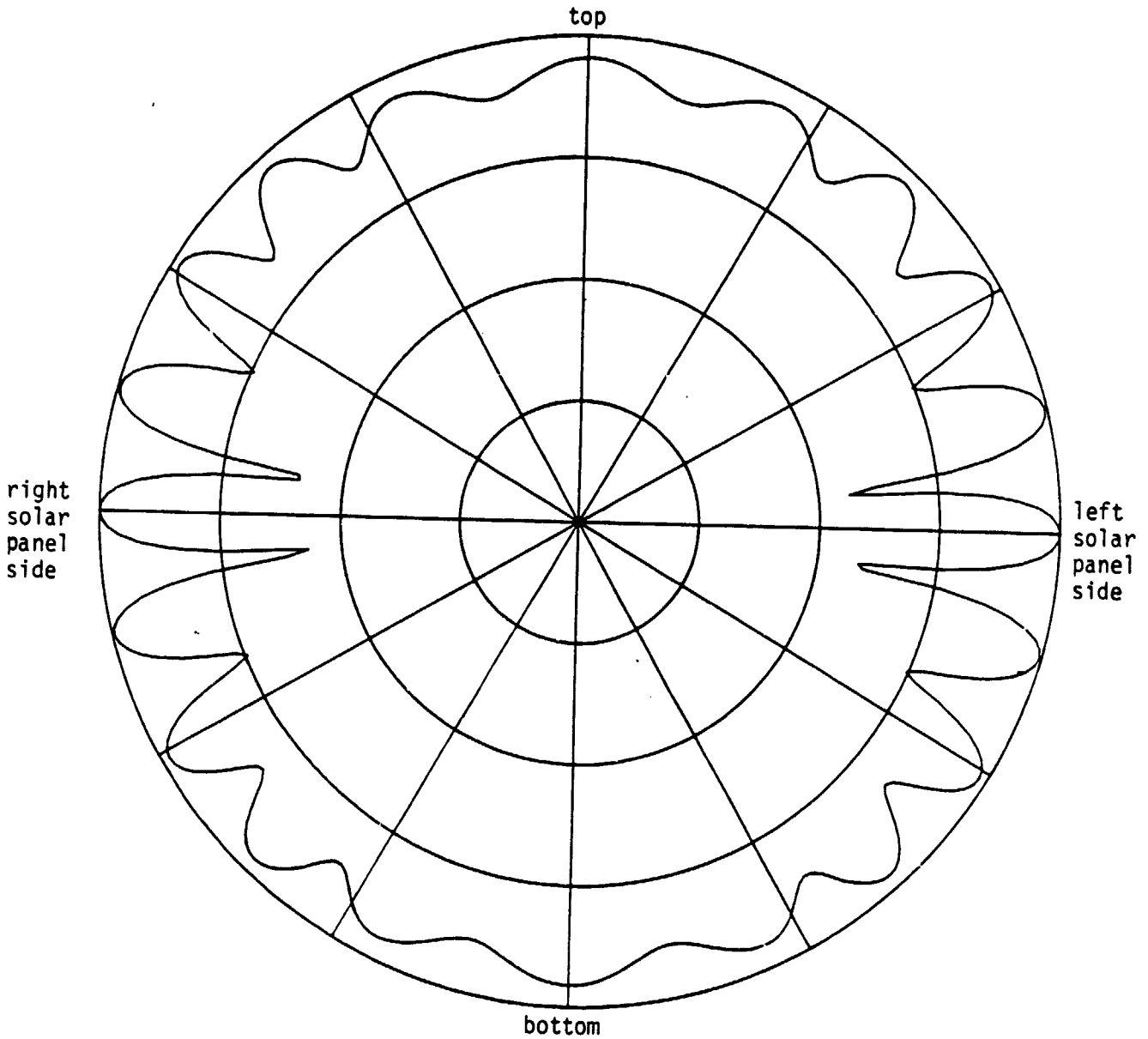

Figure III.2-38. Principal roll plane pattern at .26 GHz.
Two axial slot antennas on the top and the
bottom of main module without solar panels.

ORIGINAL PAGE IS
OF POOR QUALITY

E-PHI
DB PLOT

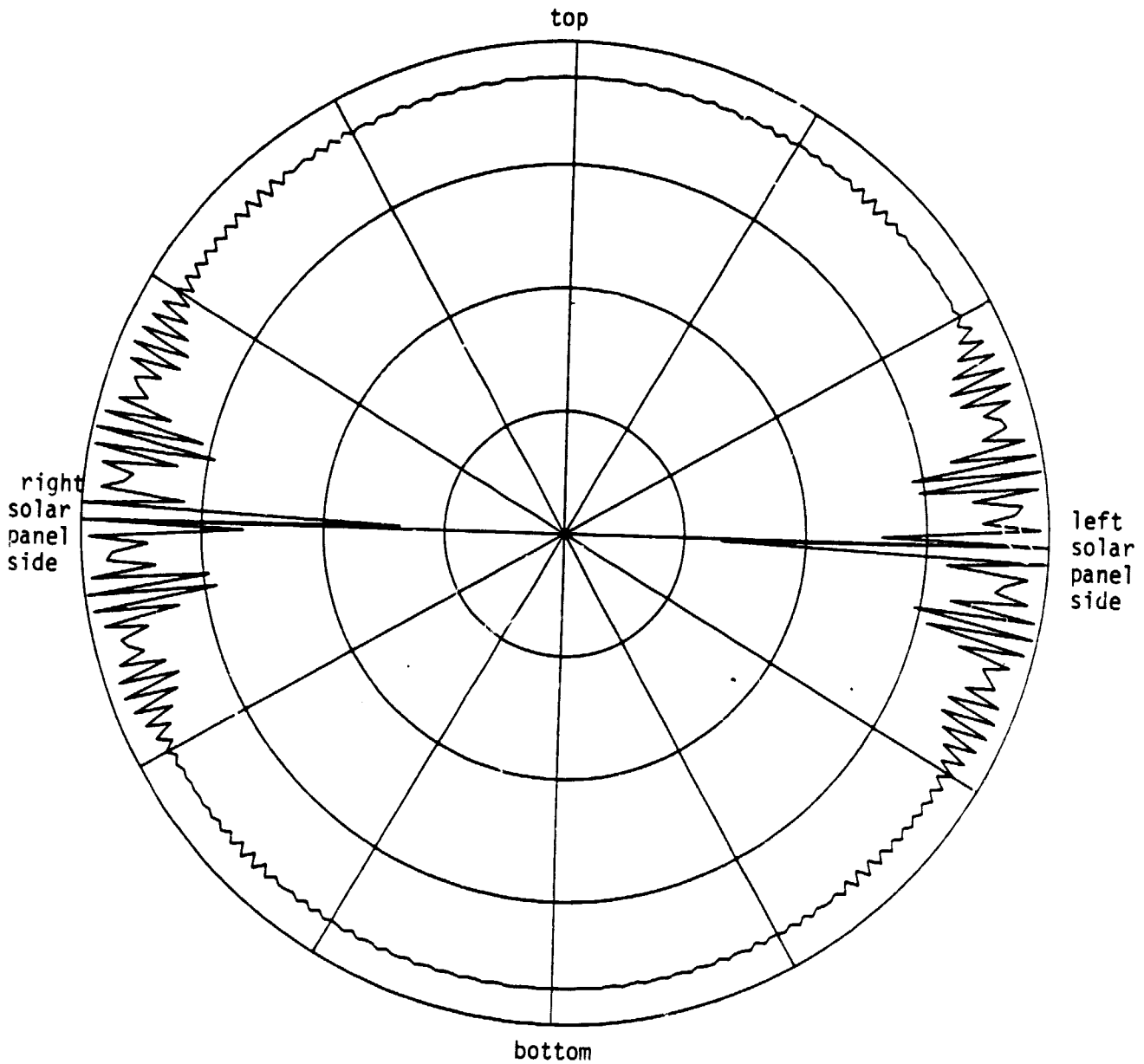

Figure III.2-39. Principal roll plane pattern at 2.2 GHz. Two axial slot antenna of main module without solar panels.

ORIGINAL PAGE 13
OF POOR QUALITY.

E-PHI
DB PLOT

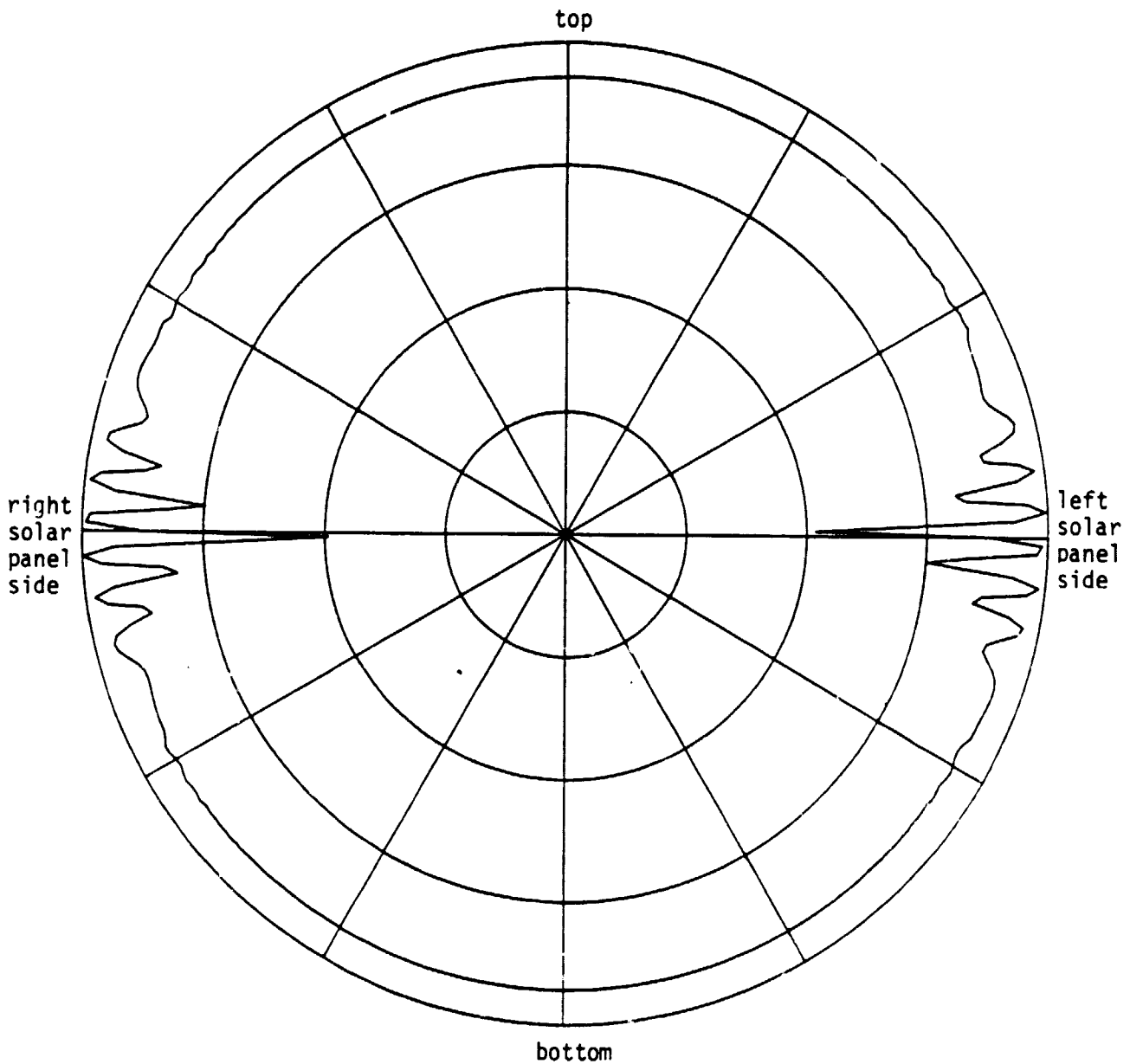
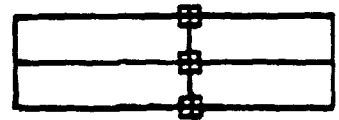

Figure III.2-40. Principal roll plane pattern at 25 GHz. Two axial slot antennas on the top and the bottom of main module without solar panels.

ORIGINAL PAGE IS
OF POOR QUALITY

MAIN MODULE OF THE SPACE STATION.
MEASURING PROFILE
(ELEVATION PLANE)



S. F. = 269-000

Figure III.2-41. Four axial slot antennas around main module without solar panels. Side view.

ORIGINAL PAGE IS
OF POOR QUALITY

FROM MIDDLE OF THE SPACE STATION.
CROSS SECTION
(ROLL PLANE)



S. F. = 288.000

Figure III.2-42. Four axial slot antennas around main module without solar panels. Front view.

ORIGINAL PAGE 13
OF POOR QUALITY

MAIN MODULE OF THE SPACE STATION.
REAR VIEW PROFILE
(AZIMUTH PLANE)

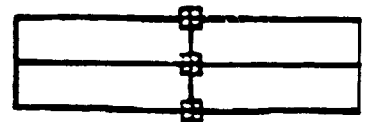

S. F. = 288-000

Figure III.2-43. Four axial slot antennas around main module without solar panels. Top view.

ORIGINAL PAGE IS
OF POOR QUALITY

E-PHI
DB PLOT

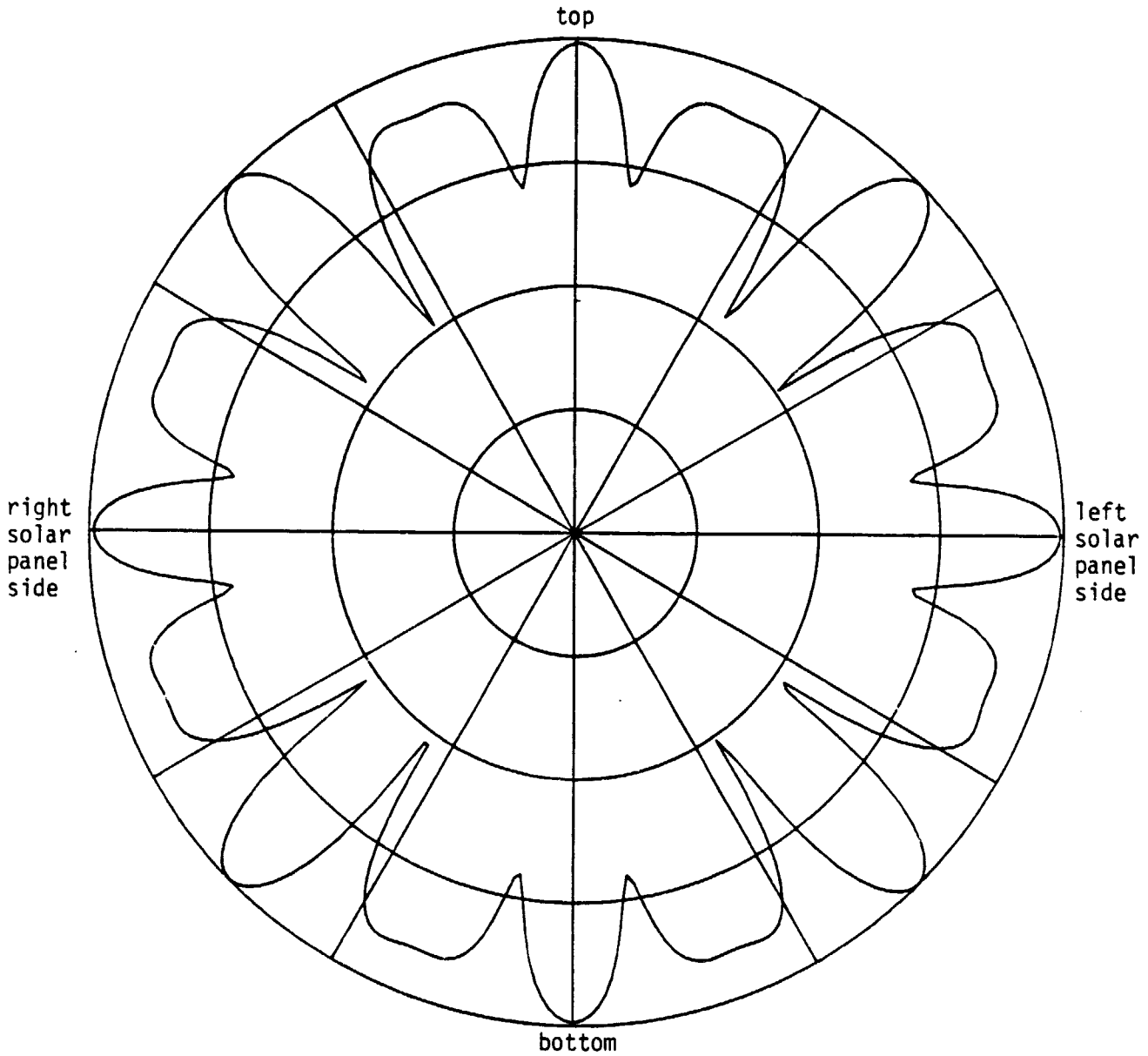

Figure III.2-44. Principal roll plane pattern at .26 GHZ.
Four axial slot antennas around main module
without solar panels.

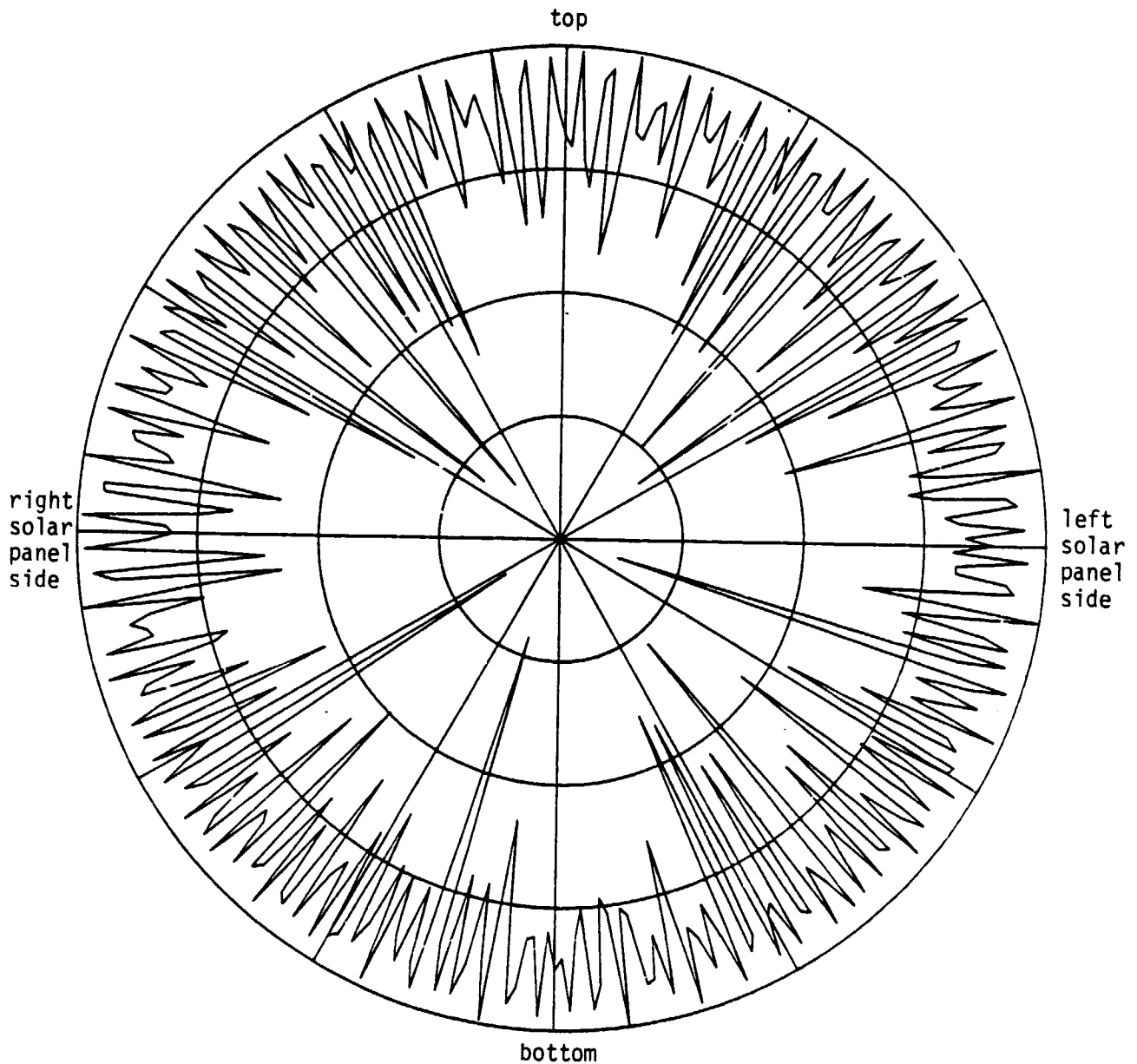

Figure III.2-45. Principal roll plane pattern at 2.2 GHz. Four axial slot antennas around main module without solar panels.

ORIGINAL PAGE IS
OF POOR QUALITY

E-PHI
DB PLOT

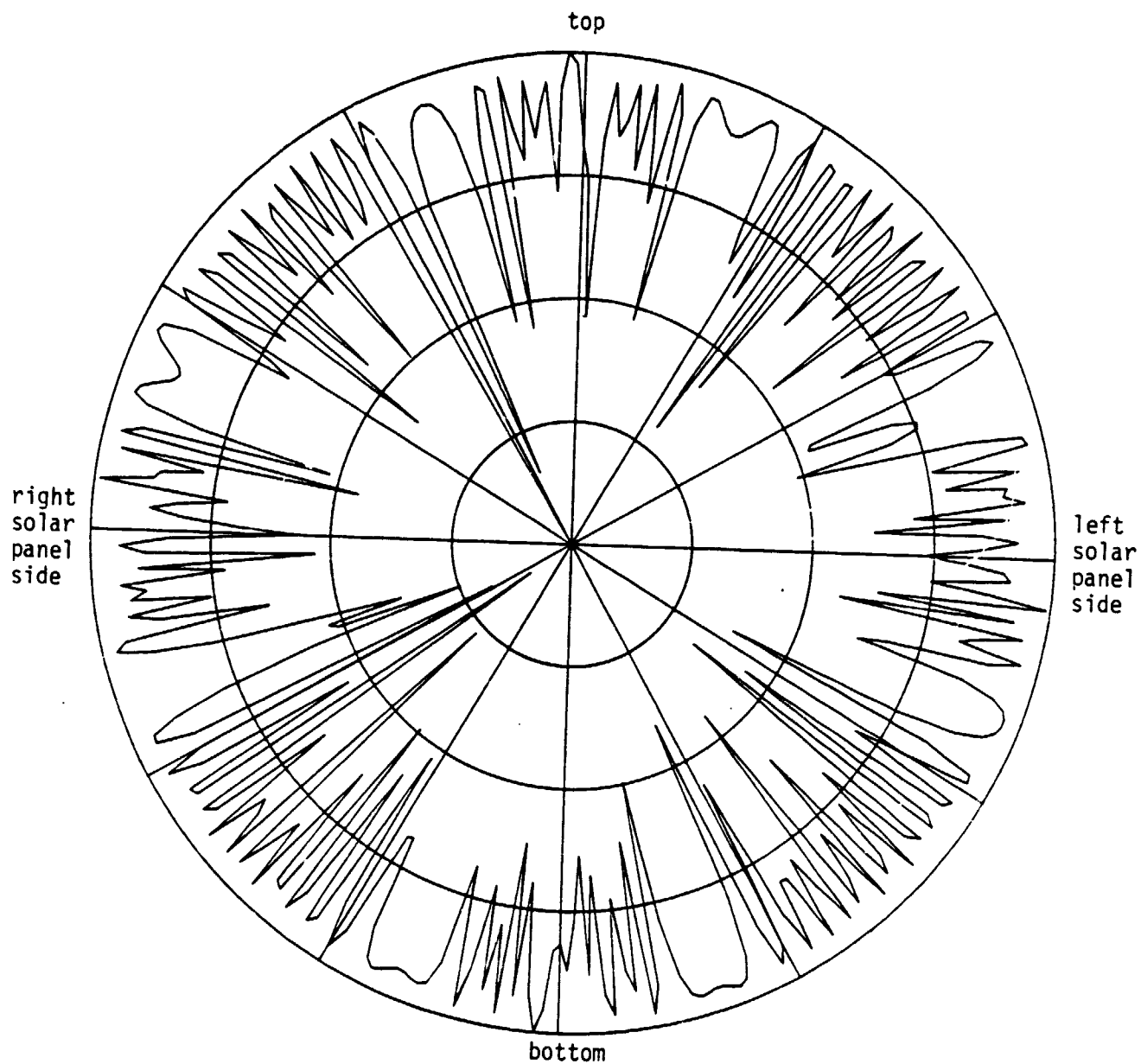

Figure III.2-46. Principal roll plane pattern at 25 GHz. Four axial slot antennas around main module without solar panels.

ORIGINAL PAGE IS
OF POOR QUALITY

```
FG MAIN MODULE WITH SOLAR PANELS.
84.0 1763.5 1763 5
0. 0. 0.
FC
T T
270.0 -270.0
PG LEFT SOLAR PANEL
4 F
0. 720. -360.
0. 4320 -360.
0. 4320 360.
0. 720 360.
PG RIGHT SOLAR PANEL
4 F
0. -720 360.
0. -4320 360.
0. -4320 -360.
0. -720 -360.
SG
0. 0.
1
0. 0.
.01 5 0. 0. 1
1. 0.
FQ 26 GHZ
1 26 1.
PP
3.75 3
PD ROLL PLANE
0. 90.
90 91 2
0 360 1
T 50000
F 3

EX
FQ 2.2 GHZ
1 2.2 1.
EX
FQ 25. GHZ
1 25. 1.
EX
END OF FILE
?? E
SOL1 IS A LOCAL FILE
/
```

Figure III.2-47. Mathematical model input data for main module with two long solar panels.

ORIGINAL PAGE IS
OF POOR QUALITY

E--PHI
DB PLOT

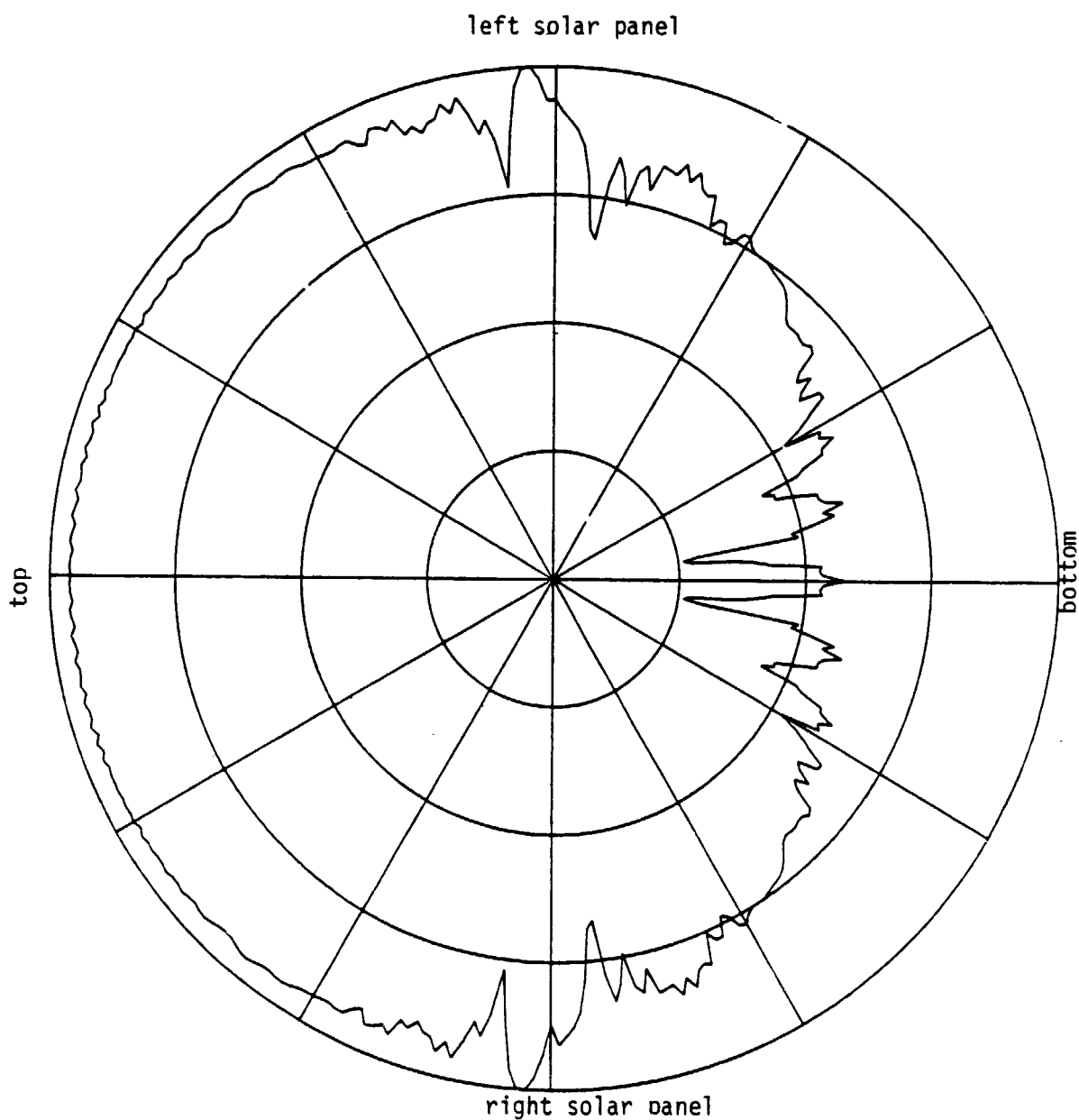

Figure III.2-48. Principal roll plane pattern at .26 GHZ. Axial slot antenna on top of main module with two long solar panels.

ORIGINAL PAGE 13
OF POOR QUALITY

E-PHI
DB PLOT

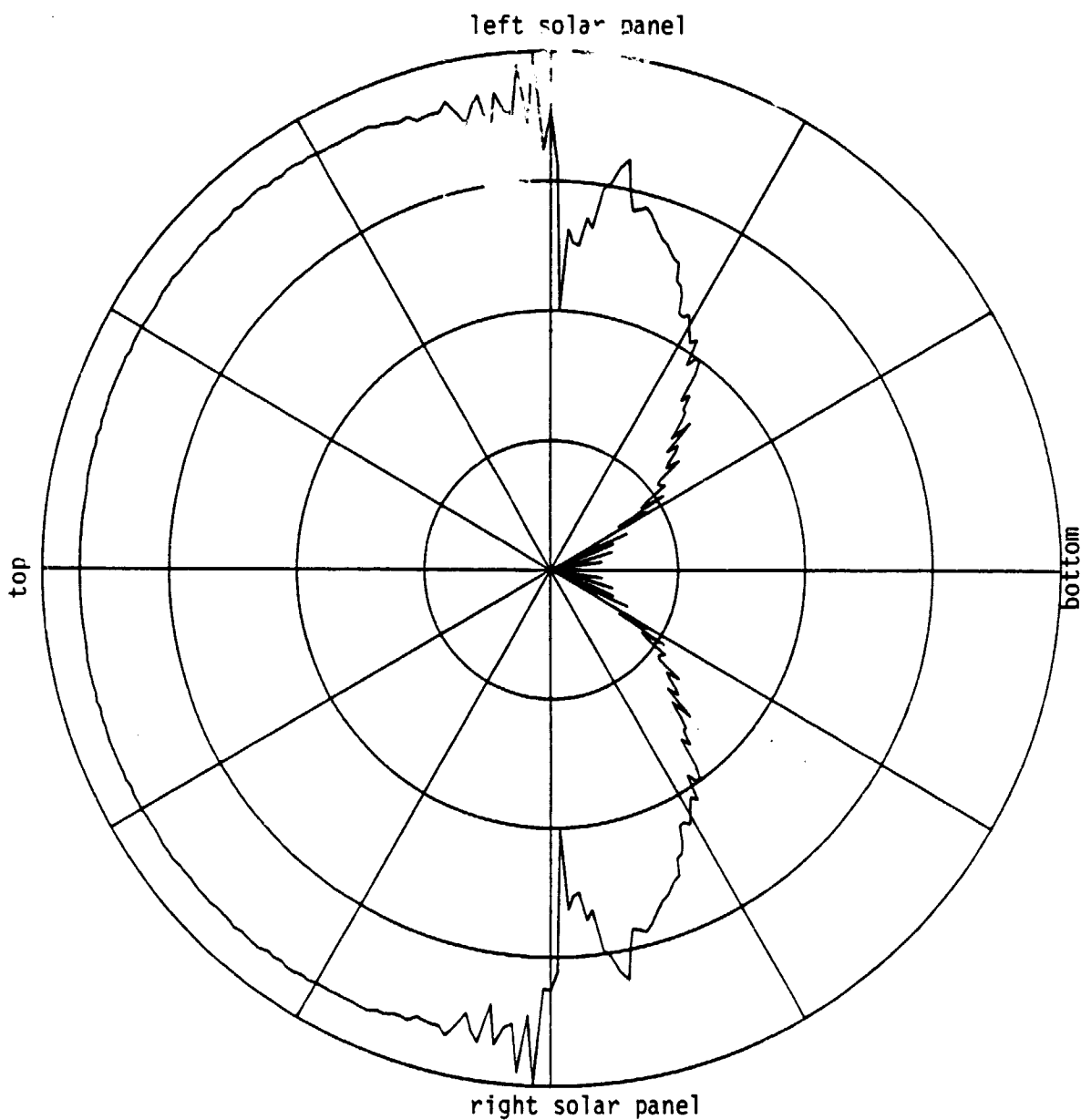

Figure III.2-49. Principal roll plane pattern at 2.2 GHz. Axial slot antenna on top of main module with two long solar panels.

ORIGINAL PAGE 13
OF POOR QUALITY

E-PHI
DB PLOT

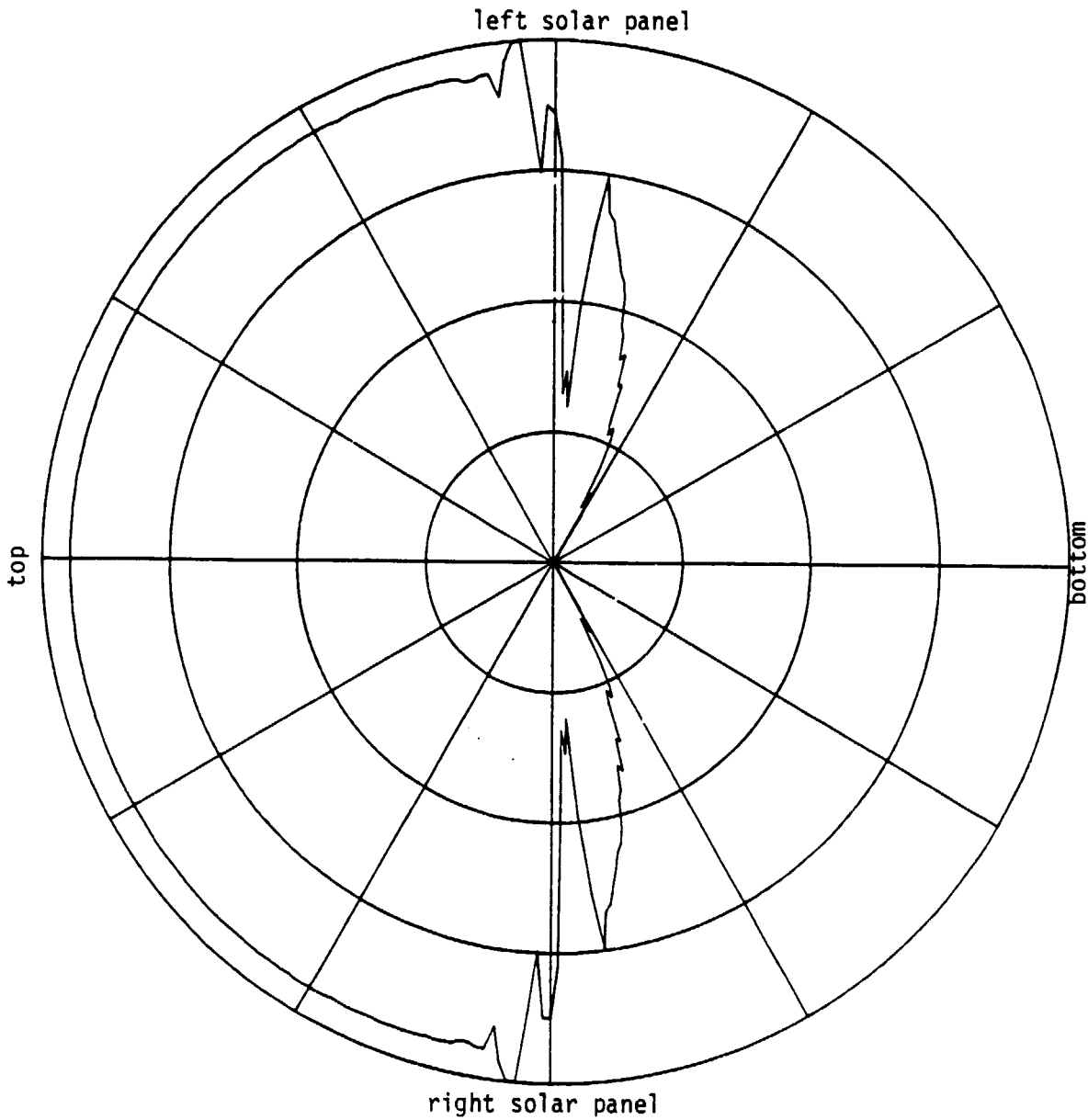

Figure III.2-50. Principal roll plane pattern at 25 GHz. Axial slot antenna on top of main module with two long solar panels.

1. SIX MODULES
(14 FT. DIA. X 46 FT LONG)
 - 0 TWO HABITAT
 - 0 TWO SERVICE
 - 0 LOGISTICS
 - 0 LABORATORY
2. THREE TRUSS PLATFORMS
(125 FT X 70 FT X 8 FT)
3. THREE CONNECTING TUNNELS
4. SOLAR CELLS ATTACHED TO
TRUSS
5. RADIATOR PANEL
6. MANIPULATOR (2)

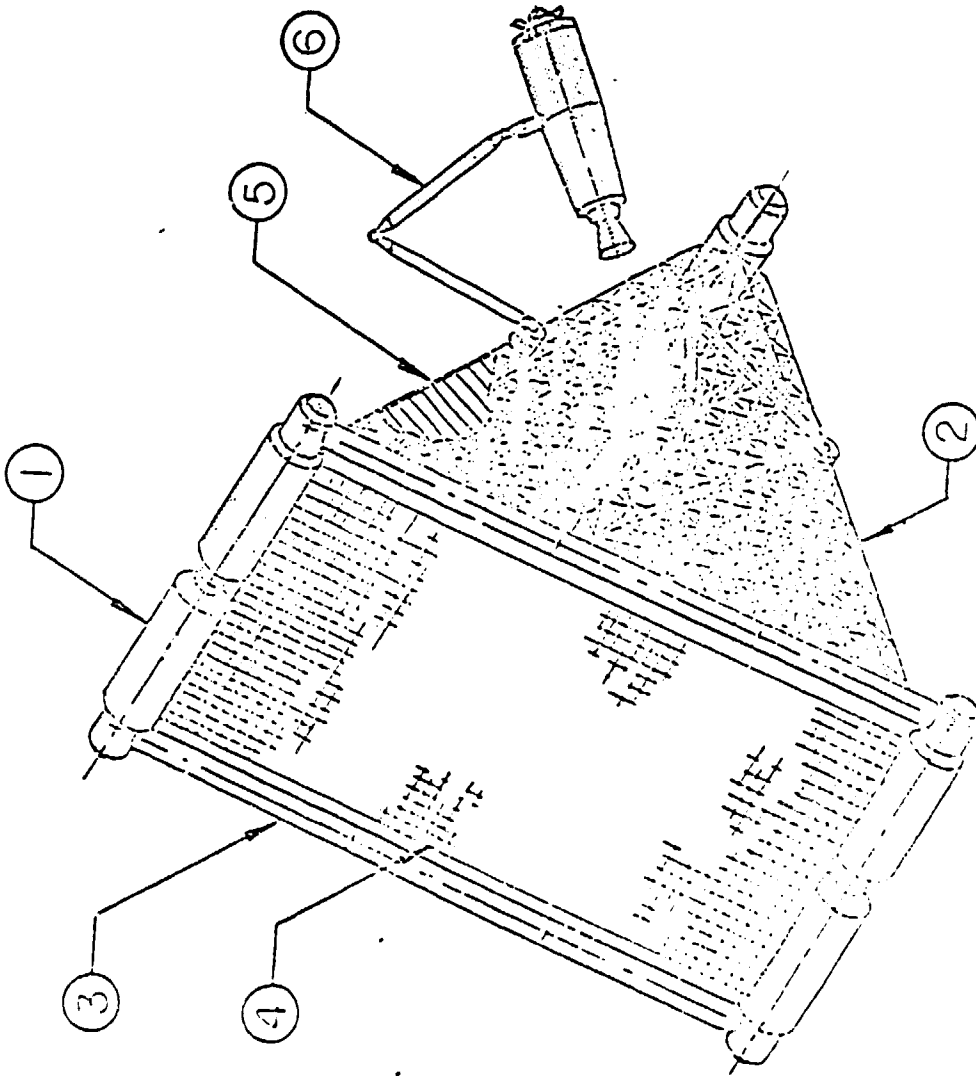

Figure III.3-1. Design of second space station.

ORIGINAL PAGE IS
OF POOR QUALITY

FQ SPACE21
84.0 1763.5 1763.5
0. 0. 0.

PP:
3.75 3

FC:
T T
552.0 -552.0

PQ LEFT SOLAR PANEL

4 T
0. 84. -420.
-1299.6 834. -420.
-1299.6 834. 420.
0. 84. 420

PQ RIGHT SOLAR PANEL

4 T
0. -84. 420.
-1299.6 -834. 420.
-1299.6 -834. -420.
0. -84. -420.

9Q:

0. 0.
1
0. 0.
.01 .5 0. 0. 1
1. 0.

FQ .26 GIGAHERTZ

1 .26 1.

PD ROLL PLANE

0. 0.
90 91 2
0 360 1
T 50000
F 3

EX:
FQ .2.2 GIGAHERTZ
1 2.2 1.
EX:
FQ .25 GIGAHERTZ
1 25 1.
EX:
END OF FILE
?? E
SPACE21 IS A LOCAL FILE
/

Figure III.3-2. Mathematical model input data for main module with two diagonal solar panels.

ORIGINAL PAGE IS
OF POOR QUALITY

SPACE STATION.
FUSelage PROFILE
(ELEVATION PLANE)

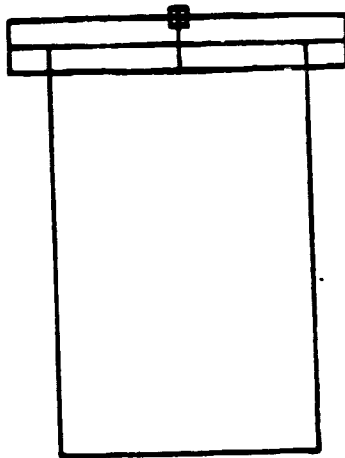

S. F. = 288.000

Figure III.3-3. Axial slot antenna on top of main module with two diagonal solar panels. Side view.

ORIGINAL PAGE IS
OF POOR QUALITY

SPACE STATION.
CROSS SECTION
(ROLL PLANE)

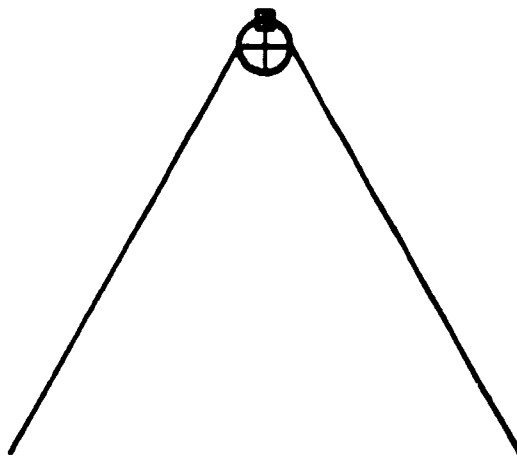

S. F. = 200.000

Figure III.3-4. Axial slot antenna on top of main module with two diagonal solar panels. Front view.

ORIGINAL PAGE IS
OF POOR QUALITY

SPACE STATION.
HEADING PROFILE
(AZIMUTH PLANE)

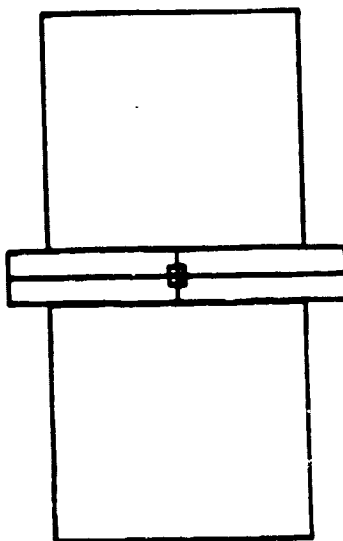

S. F. = 288.000

Figure III.3-5. Axial slot antenna on top of main module
with two diagonal solar panels. Top view.

ORIGINAL PAGE IS
OF POOR QUALITY.

E-PHI
DB PLOT

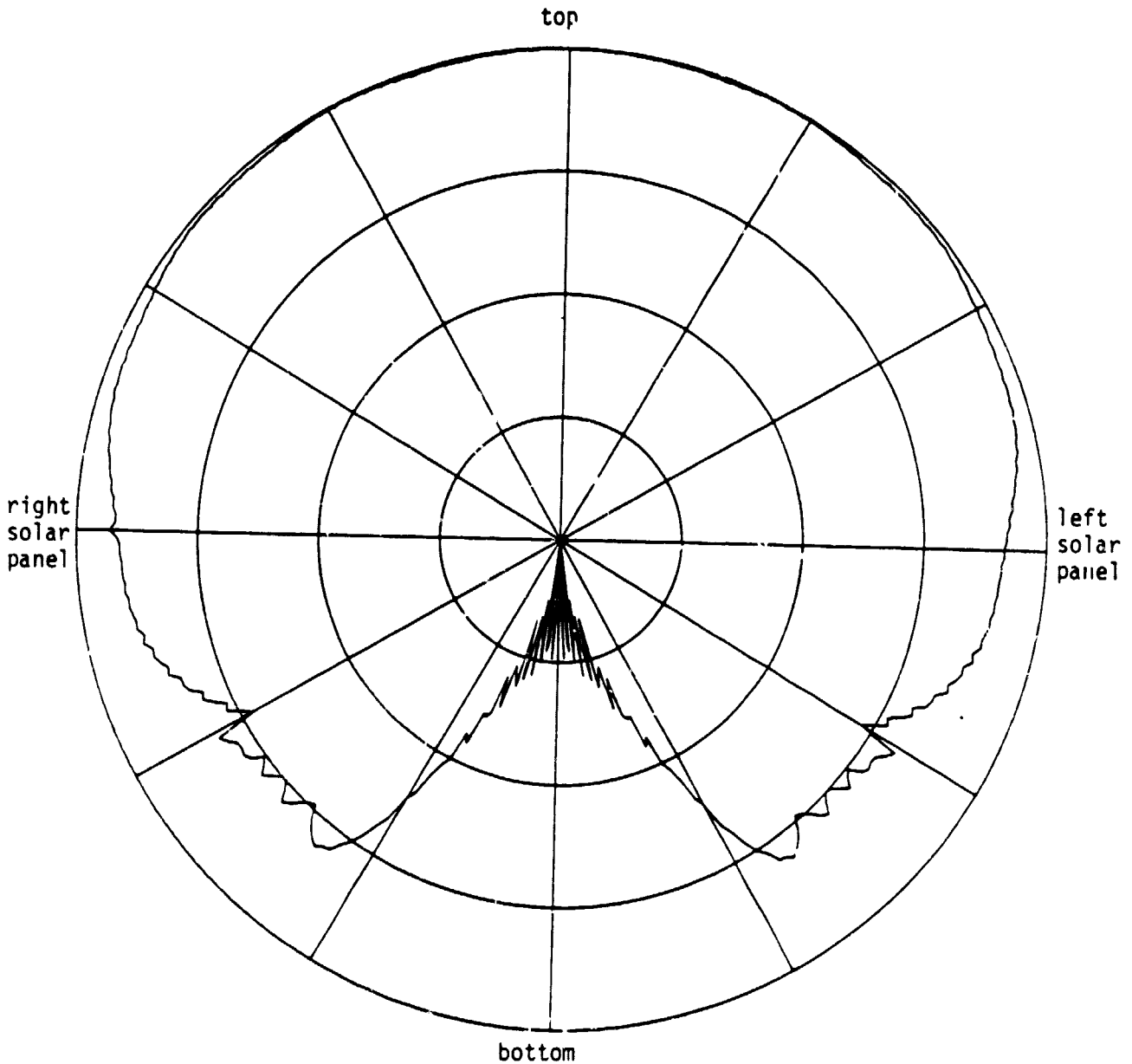

Figure III.3-6. Principal roll plane pattern at .26 GHz. Axial slot antenna on top of main module with two diagonal solar panels.

ORIGINAL PAGE IS
OF POOR QUALITY

E-PHI
DB PLOT

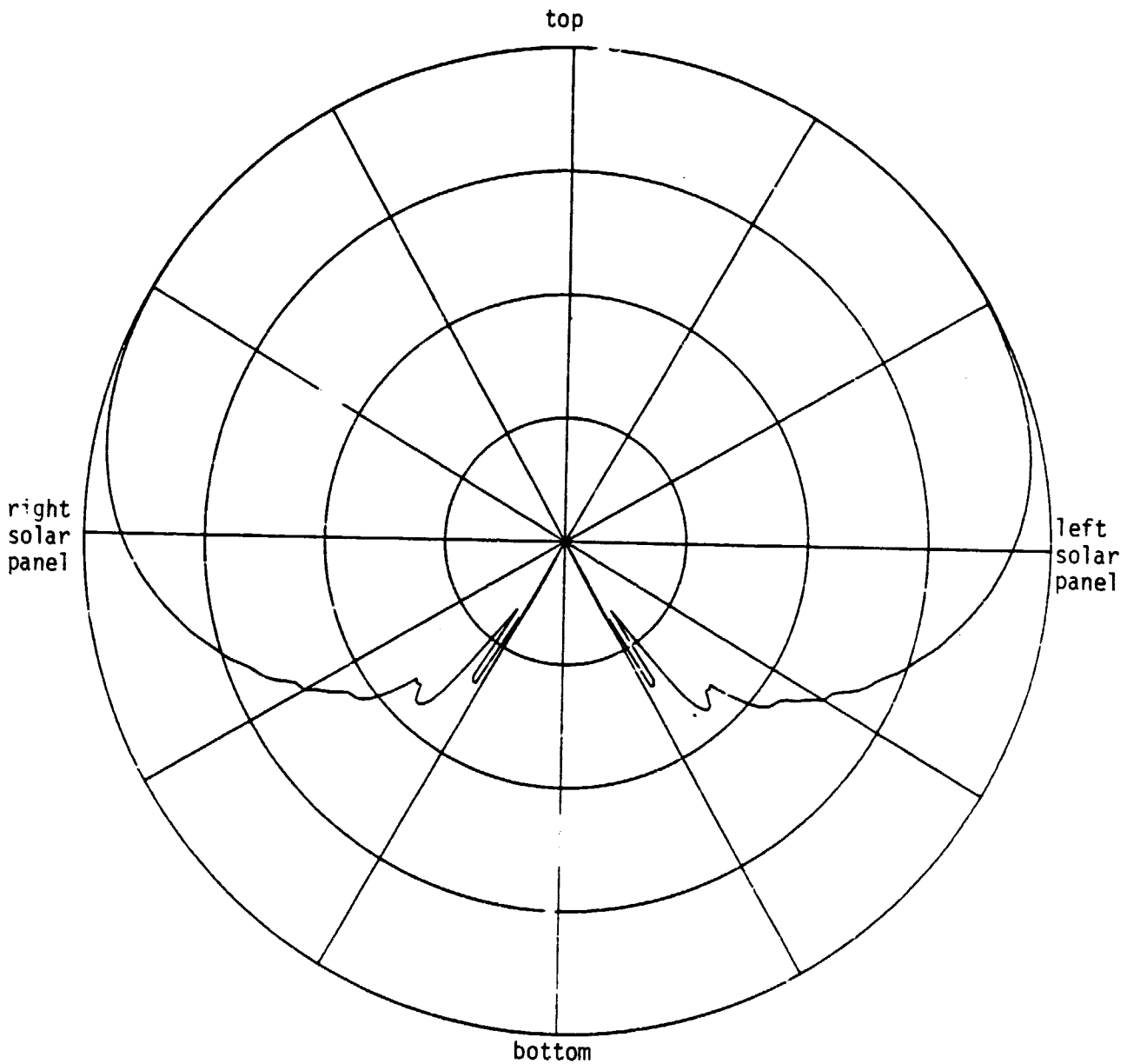

Figure III.3-7. Principal roll plane pattern at 2.2 GHz. Axial slot antenna on top of main module with two diagonal solar panels.

ORIGINAL PAGE IS
OF POOR QUALITY

E-PHI
DB PLOT

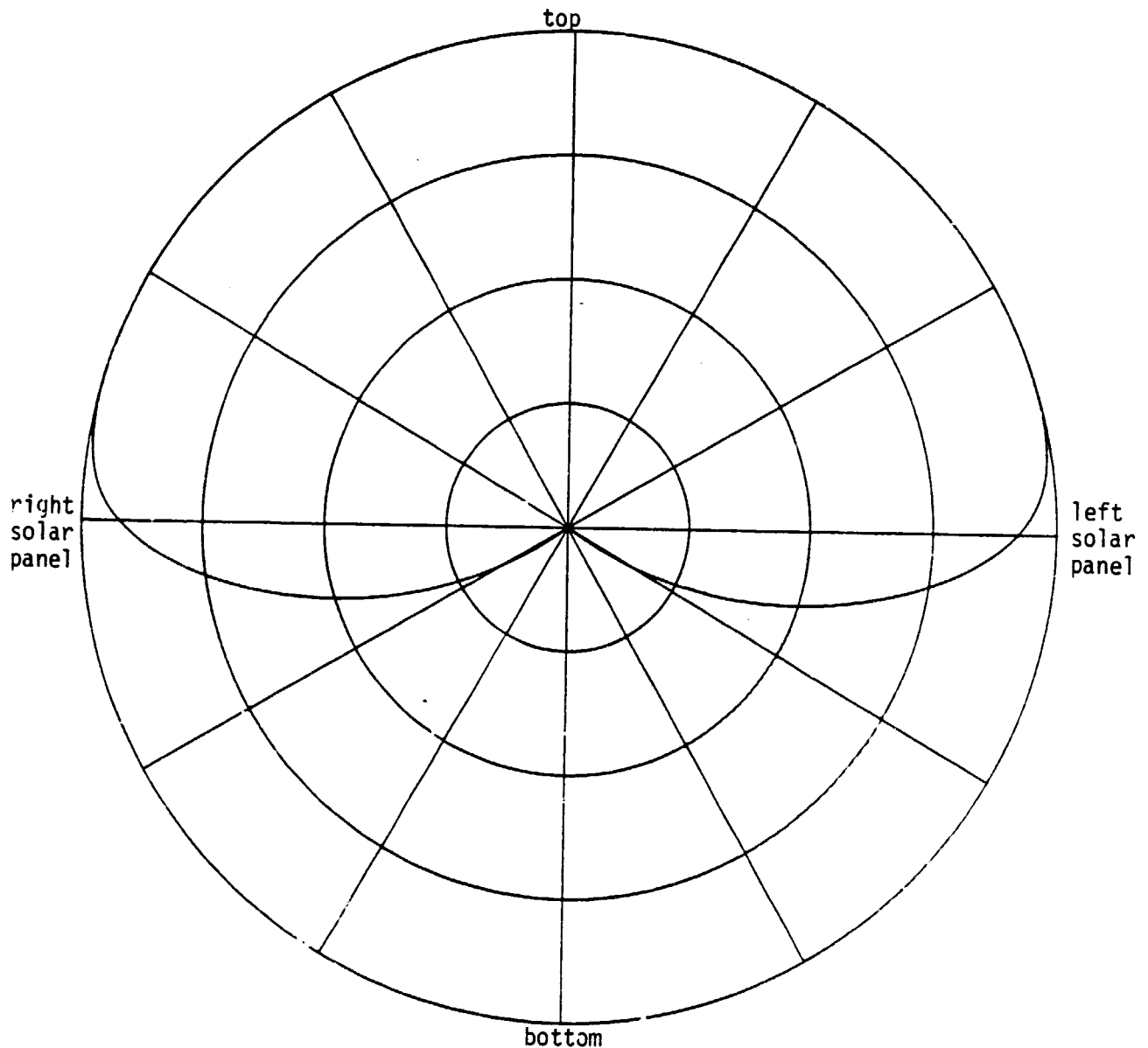
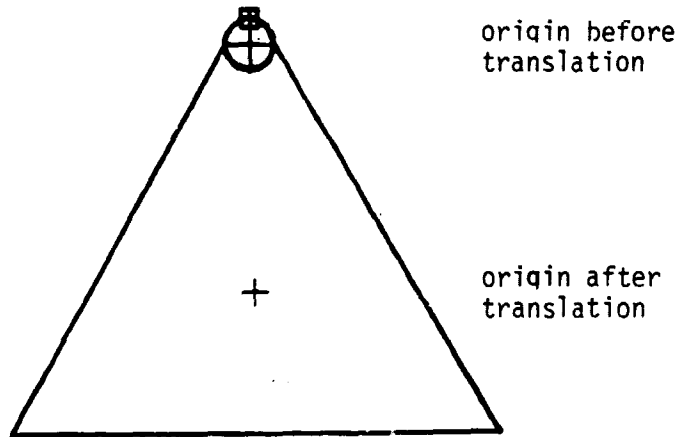

Figure III.3-8. Principal roll plane pattern at 25 GHz. Axial slot antenna on top of main module with two diagonal solar panels.

ORIGINAL PAGE IS
OF POOR QUALITY

MAIN MODULE, SOLAR PANELS, BOTTOM TRUSS PLATFORM.
CROSS SECTION
(ROLL PLANE)



S. F. = 288.000

Figure III.3-9. Origin of coordinate axis before and after translation.

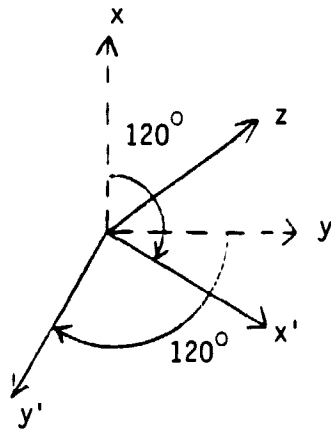

A- Coordinate axis x' and y' after 120° rotation around z axis, used for simulation of right module.

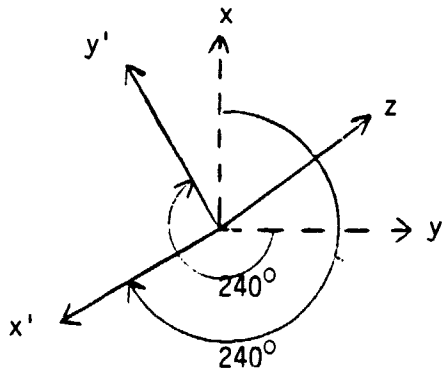

B. Coordinate axis x' and y' after 240° rotation around z axis, used for simulation of left module.

Figure III.3-10. Coordinate axis before and after rotation around z axis after translation of origin.

ORIGINAL PAGE IS
OF POOR QUALITY

```

FG SPACE27
 84.0 1763 5 1763.5
 0. 0. 0.
PP.
 3.75 3
FC.
 T T
 552 0 -552 0
PG LEFT SOLAR PANEL
 4 T
 0. 84. -420.
-1299.6 834. -420.
-1299.6 834. 420.
 0. 84. 420.
PG RIGHT SOLAR PANEL
 4 T
 0. -84. 420.
-1299.6 -834. 420.
-1299.6 -834. -420.
 0. -84. -420.
PG BOTTOM TRUSS PLATFORM
 4 F
-1299.6 834. 420.
-1299.6 834. -420.
-1299.6 -834. -420.
-1299.6 -834. 420.
SG.
 0. 0.
 1
 0. 0.
 .01 .5 0. 0. 1
 1. 0.
FQ .26 GIGAHERTZ
 1 .26 1.

PD ROLL PLANE
 0. 0.
 90 91 2
 0 360 1
 T 50000
 F 3
EX.
SG.
-45. 0.
 1
 0. 0.
 .01 .5 0. 0. 1
 1. 0.
SP.
 T 1. 0.
RT.
-649.8 0. 0.
 0. 0. 90. 0.
PD ROLL PLANE
 0. 120.
 90 91 2
 0 360 1
 T 50000
 F 3
EX.
END OF FILE
?? E
SPACE27 IS A LOCAL FILE
/

```

Figure III.3-11. Mathematical model input data for main module, two diagonal solar panels and bottom truss platform. Two axial slot antennas; one on the main module, the other on the right module.

ORIGINAL DRAWING
OF POOR QUALITY

SPACE 27
FUSelage PROFILE
(ELEVATION PLANE)

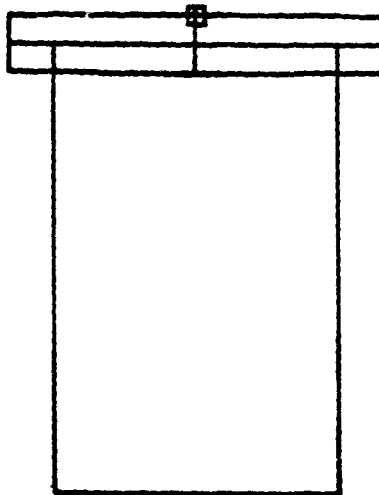

S. F. = 288.000

Figure III.3-12. Axial slot antenna on top of the main module with two diagonal solar panels and bottom truss platform. Side view.

ORIGINAL PAGE IS
OF POOR QUALITY

SPACE27
CROSS SECTION
(ROLL PLANE)

S. F. = 288.000

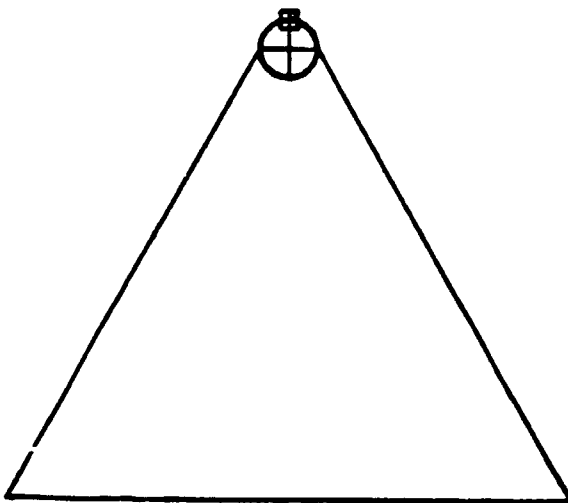
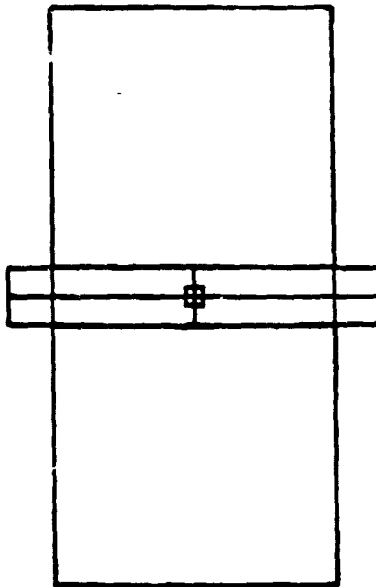

Figure III.3-13. Axial slot antenna on top of the main module with two diagonal solar panels and bottom truss platform. Front view.

ORIGINAL PAGE IS
OF POOR QUALITY

SPACE27
HEADING PROFILE
(AZIMUTH PLANE)



S. F. = 288.000

Figure III.3-14. Axial slot antenna on top of the main module with two diagonal solar panels and bottom truss platform. Top view.

ORIGINAL PAGE 13
OF POOR QUALITY

E-PHI
DB PLOT

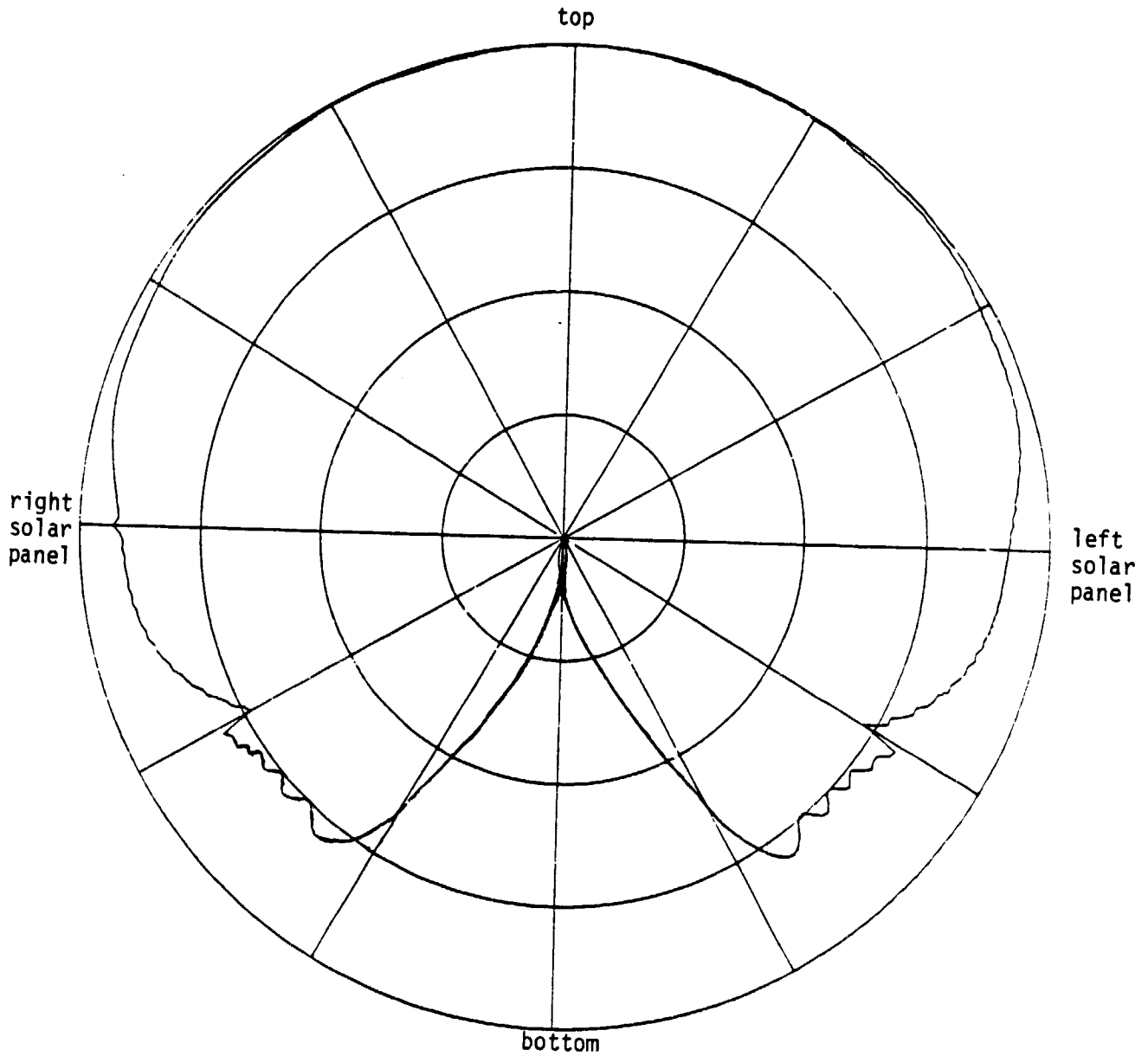

Figure III.3.15. Principal roll plane pattern at .26 GHZ. Axial slot antenna on top of main module with two diagonal solar panels and bottom truss platform.

ORIGINAL PAGE IS
OF POOR QUALITY

E-PHI
DB PLOT

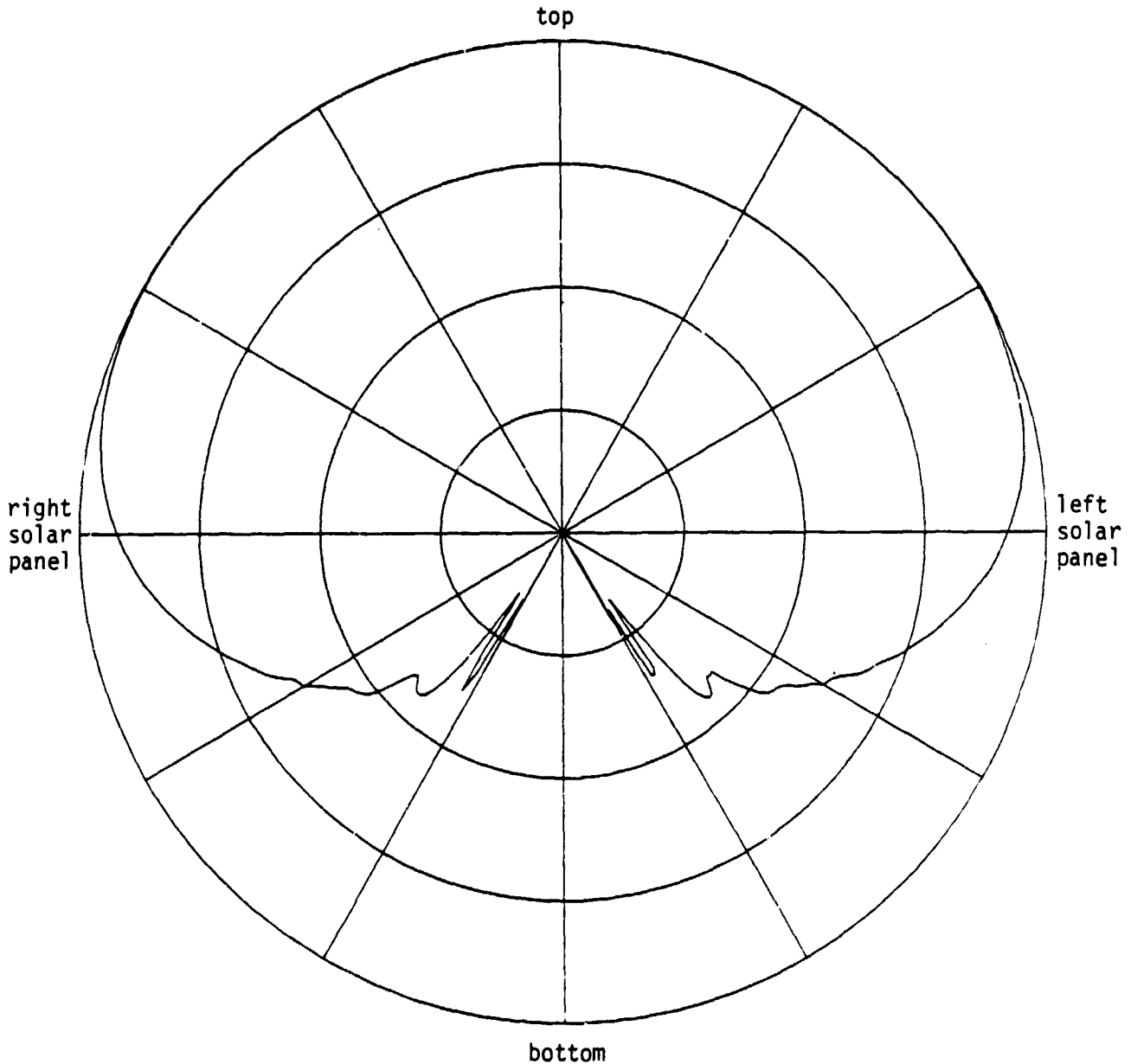

Figure III.3.16. Principal roll plane pattern at 2.2 GHz. Axial slot antenna on top of main module with two diagonal solar panels and bottom truss platform.

ORIGINAL PAGE IS
OF POOR QUALITY

E-PHI
DB PLOT

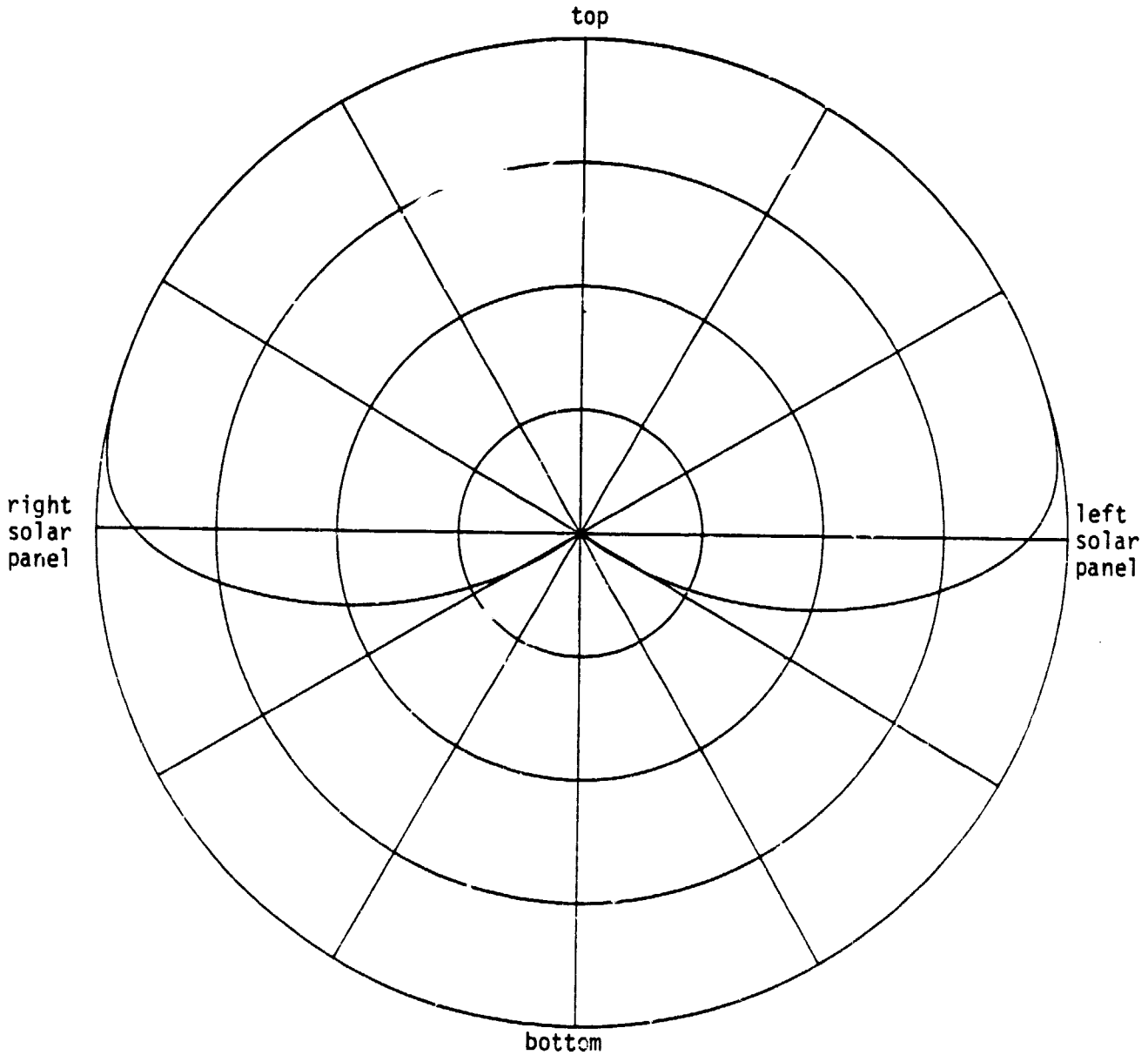
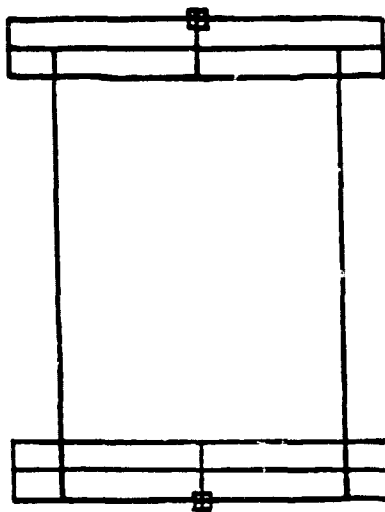

Figure III.3-17. Principal roll plane pattern at 25 GHz. Axial slot antenna on top of main module with two diagonal solar panels and bottom truss platform.

ORIGINAL PAGE IS
OF POOR QUALITY

SPACE27
FUELRAGE PROFILE
(ELEVATION PLANE)



S. F. s 298.000

Figure III.3- 8. Two axial slot antennas; one on top of the main module, the other on the right module, with two diagonal solar panels and bottom truss platform Side view.

ORIGINAL PAGE IS
OF POOR QUALITY

SPACE27
CROSS SECTION
(ROLL PLANE)

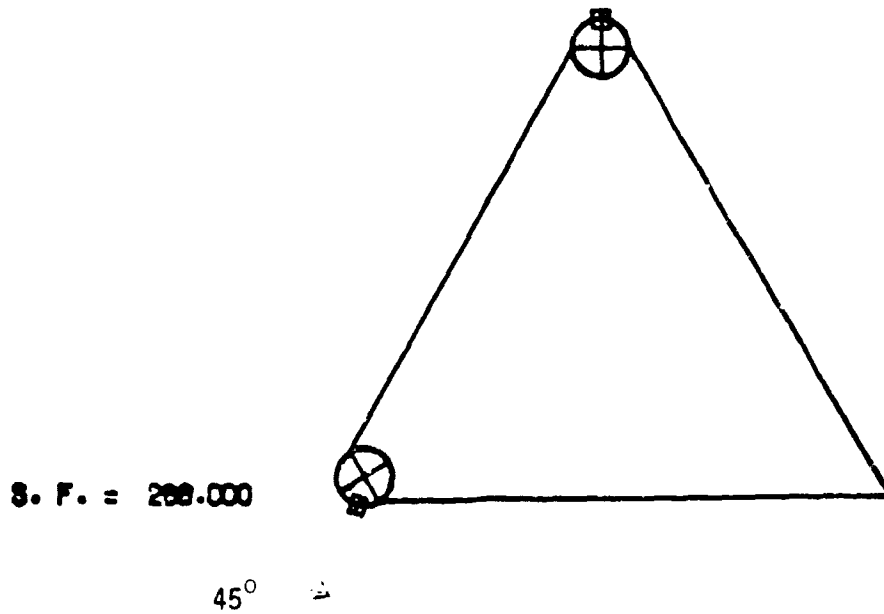
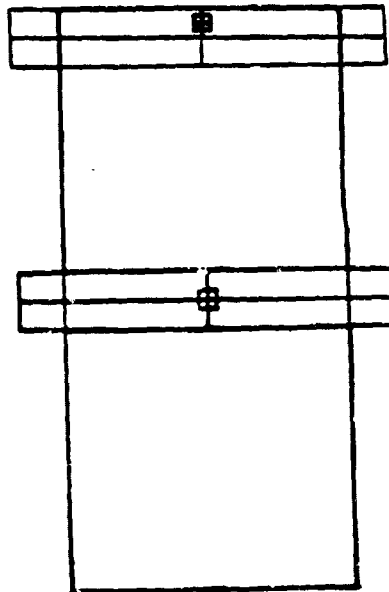

Figure III.3-19. Two axial slot antennas; one on top of the main module, the other on the right module, with two diagonal solar panels and bottom truss platform. Front view.

ORIGINAL PAGE IS
OF POOR QUALITY.

SPACE 27
HEADING PROFILE
(AZIMUTH PLANE)



S. F. = 200.000

Figure III.3-20. Two axial slot antennas; one on top of the main module, the other on the right module, with two diagonal solar panels and bottom cross platform. Top view.

ORIGINAL PAGE IS
OF POOR QUALITY

E-PHI
DB PLOT

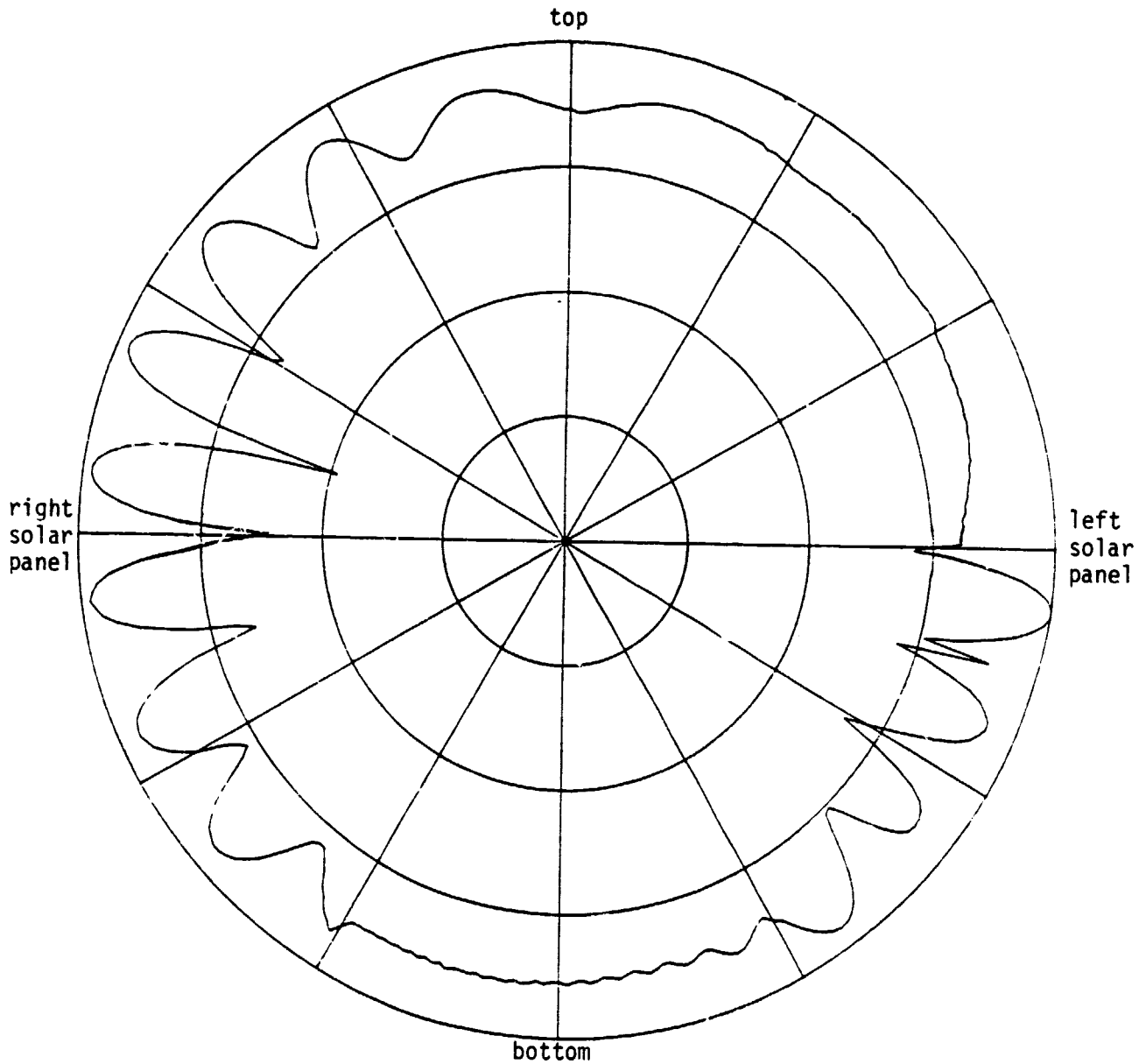

Figure III.3-21. Principal roll plane pattern at .26 GHZ. Two axial slot antenna; one on top of main module, the other on the right module.

C-2

ORIGINAL PAGE IS
OF POOR QUALITY

E-PHI
DB PLOT

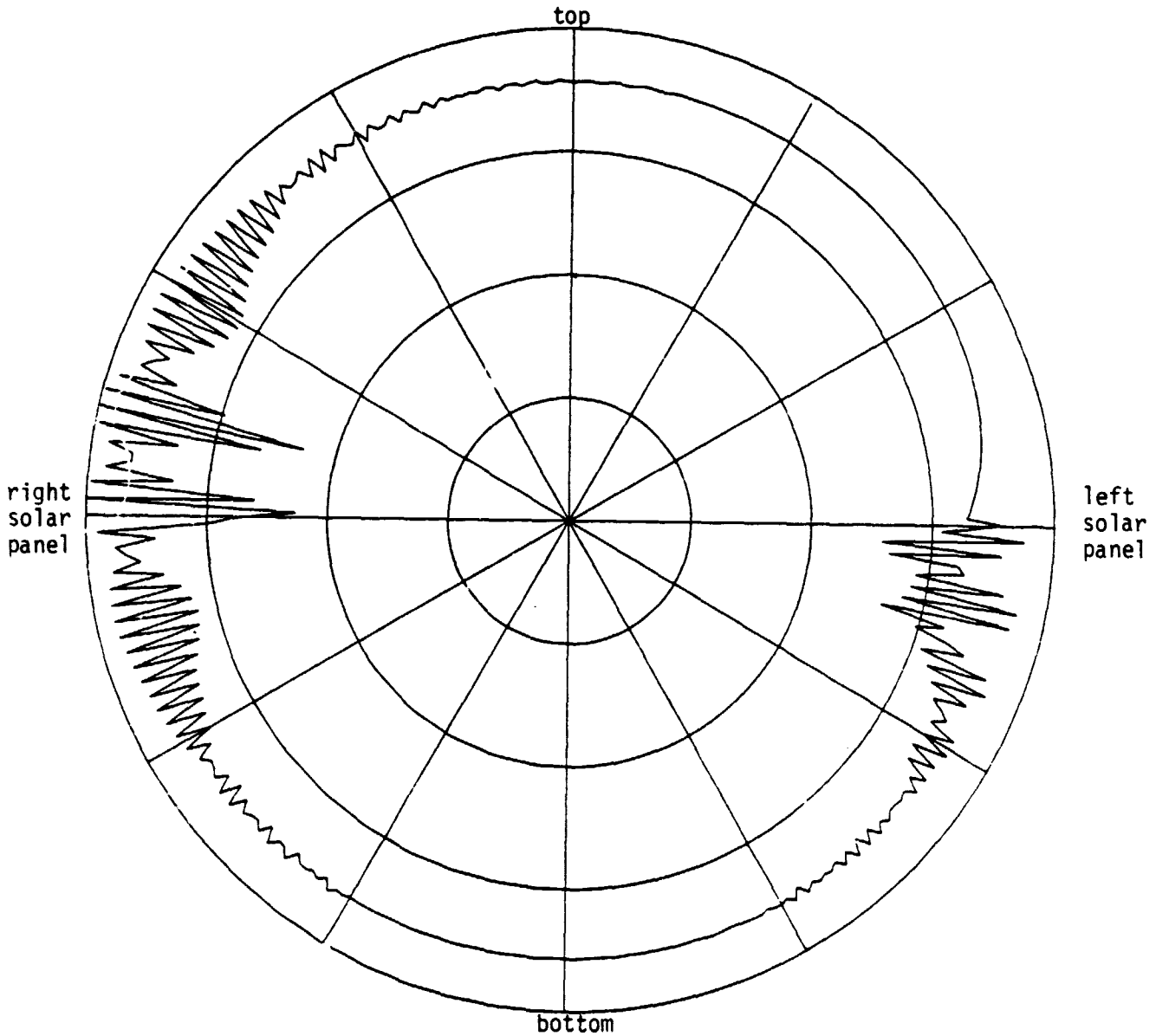

Figure III.3-22. Principal roll plane pattern at 2.2 GHz. Two axial slot antennas; one on top of main module, the other on the right module.

ORIGINAL PAGE IS
OF POOR QUALITY

E--PHI
DB PLOT

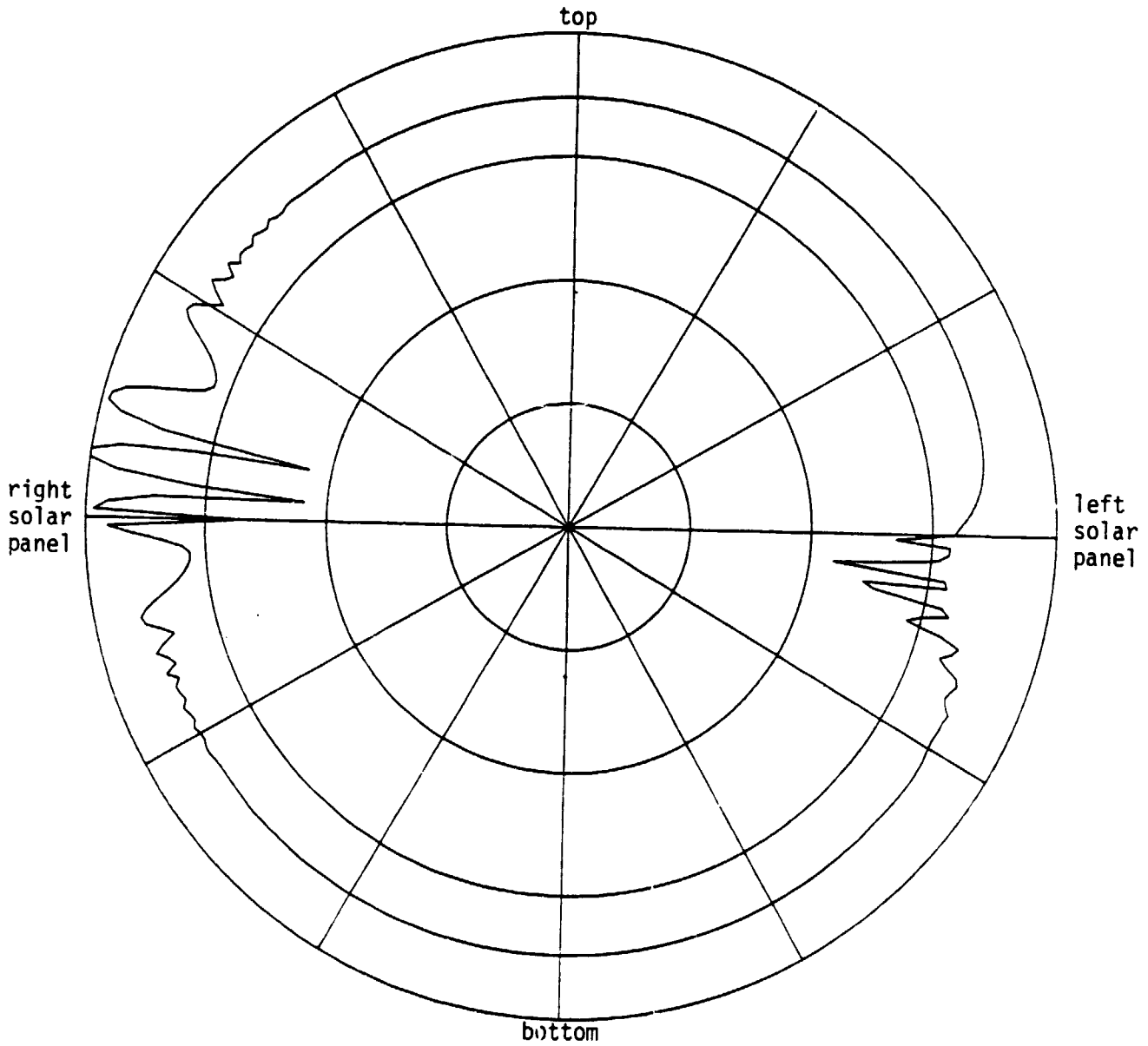

Figure III.3-23. Principal roll plane pattern at 25 GHz. Two axial slot antennas; one on top of main module, the other on the right module.

ORIGINAL PAGE IS
OF POOR QUALITY

```

FG SPACE29
 84.0 1763.5 1763.5
 0. 0. 0.
PP:
 3.75 3
FC:
 T T
 552.0 -552.0
PG LEFT SOLAR PANEL
 4 T
 0. 84. -420.
-1299.6 834. -420.
-1299.6 834. 420.
 0. 84. 420.
PG RIGHT SOLAR PANEL
 4 T
 0. -84. 420.
-1299.6 -834. 420.
-1299.6 -834. -420.
 0. -84. -420.
PG BOTTOM TRUSS PLATFORM
 4 F
-1299.6 834. 420.
-1299.6 834. -420.
-1299.6 -834. -420.
-1299.6 -834. 420.
SQ:
 0. 0.
 1
 0. 0.
 01 5 0 0 1
 1. 0.
FO: .26 GIGAHERTZ
 1 .26 1.

```

```

PD ROLL PLANE
 0. 0.
 90 91 2
 0 360 1
 T 50000
 F 3
EX:
SP:
 T 1. 0.
RT:
-649.8 0. 0.
 0. 0. 90. 0.
PD ROLL PLANE
 0. 119.9
 90 91 2
 0 360 1
 T 50000
 F 3
EX:
PD:
 0. 239.9
 90 91 2
 0 360 1
 T 50000
 F 3
EX:
END OF FILE
?? E
SPACE29 IS A LOCAL FILE
/

```

Figure III.3-24. Mathematical model input data for main module, two diagonal solar panels and bottom truss platform. Three axial slot antennas; one on each module.

ORIGINAL PAGE IS
OF POOR QUALITY

SPACE27
FUSelage PROFILE
(ELEVATION PLANE)

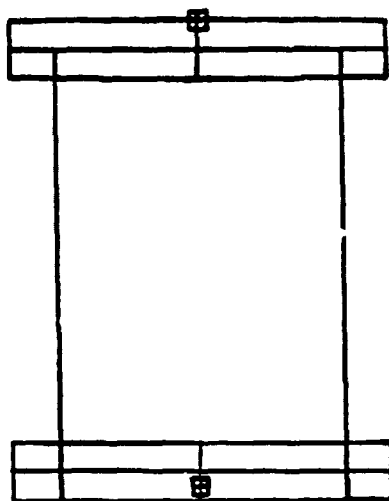

S. F. = 288.000

Figure III.3-25. Three axial slot antennas on each module, with two diagonal solar panels and bottom truss platform. Side view.

ORIGINAL PAGE IS
OF POOR QUALITY

SPACE27
CROSS SECTION
(ROLL PLANE)

S. F. = 288.000

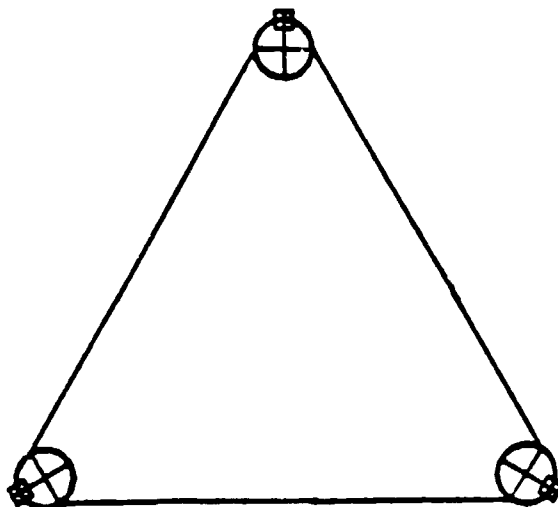
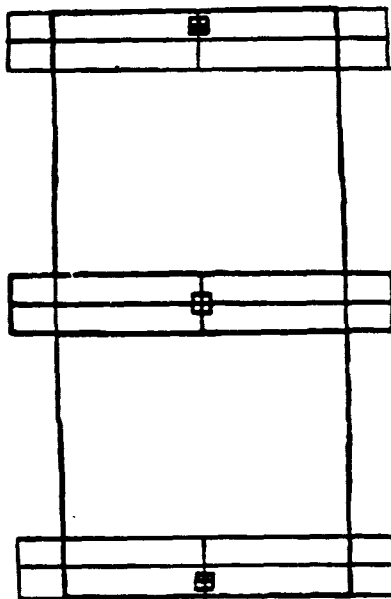

Figure III.3-26. Three axial slot antennas on each module, with two diagonal solar panels and bottom truss platform. Front view.

ORIGINAL PAGE IS
OF POOR QUALITY

SPACE27
HEADING PROFILE
(AZIMUTH PLANE)



S. F. = 288.000

Figure III.3-27. Three axial slot antennas on each main module, with two diagonal solar panels and bottom truss platform. Top view.

ORIGINAL PAGE IS
OF POOR QUALITY

E-PHI
DB PLOT

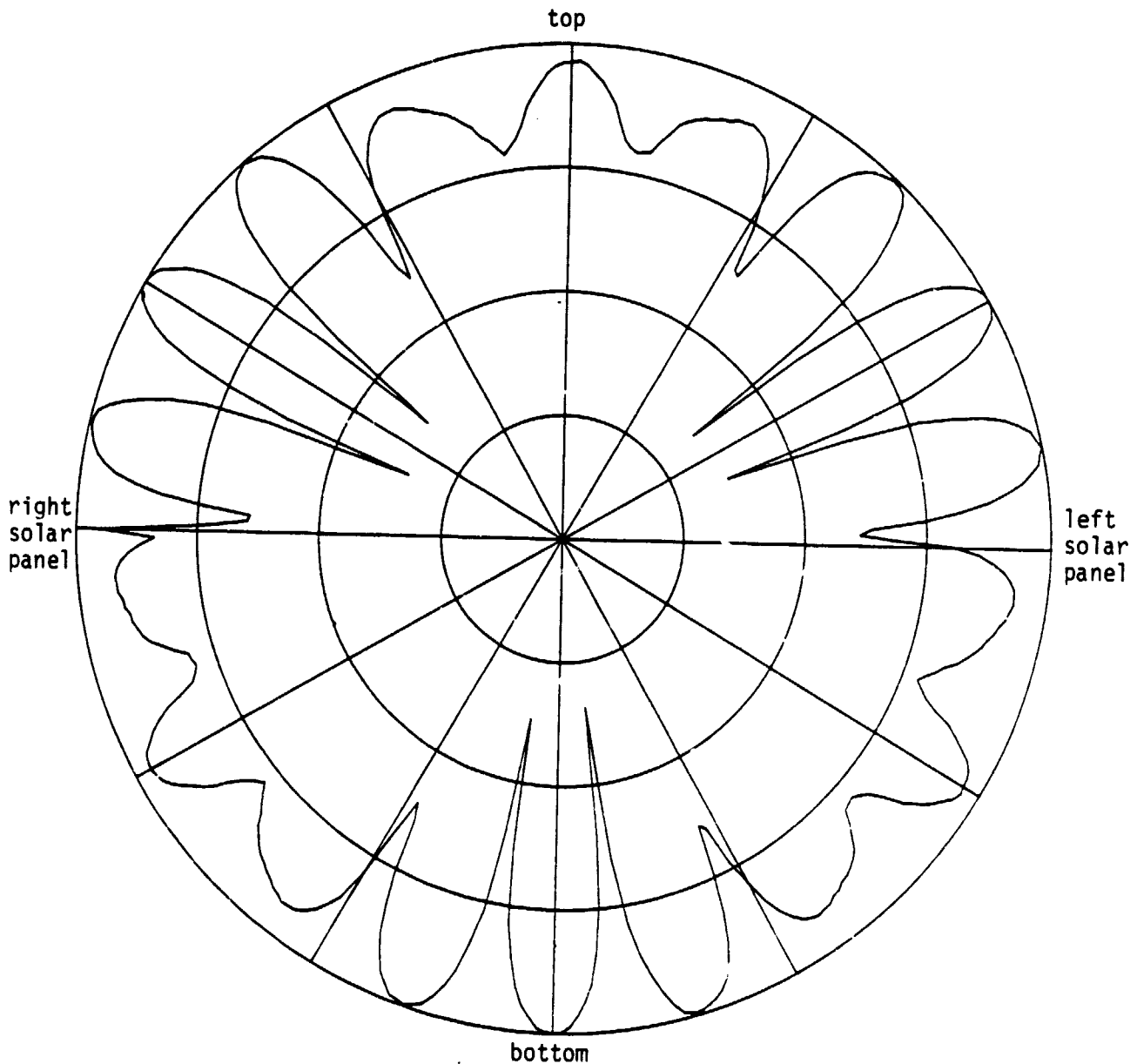

Figure III.3-28. Principal roll plane pattern at .26 GHZ. Three axial slot antennas on top of each module.

ORIGINAL PAGE IS
OF POOR QUALITY

E-PHI
DB PLOT

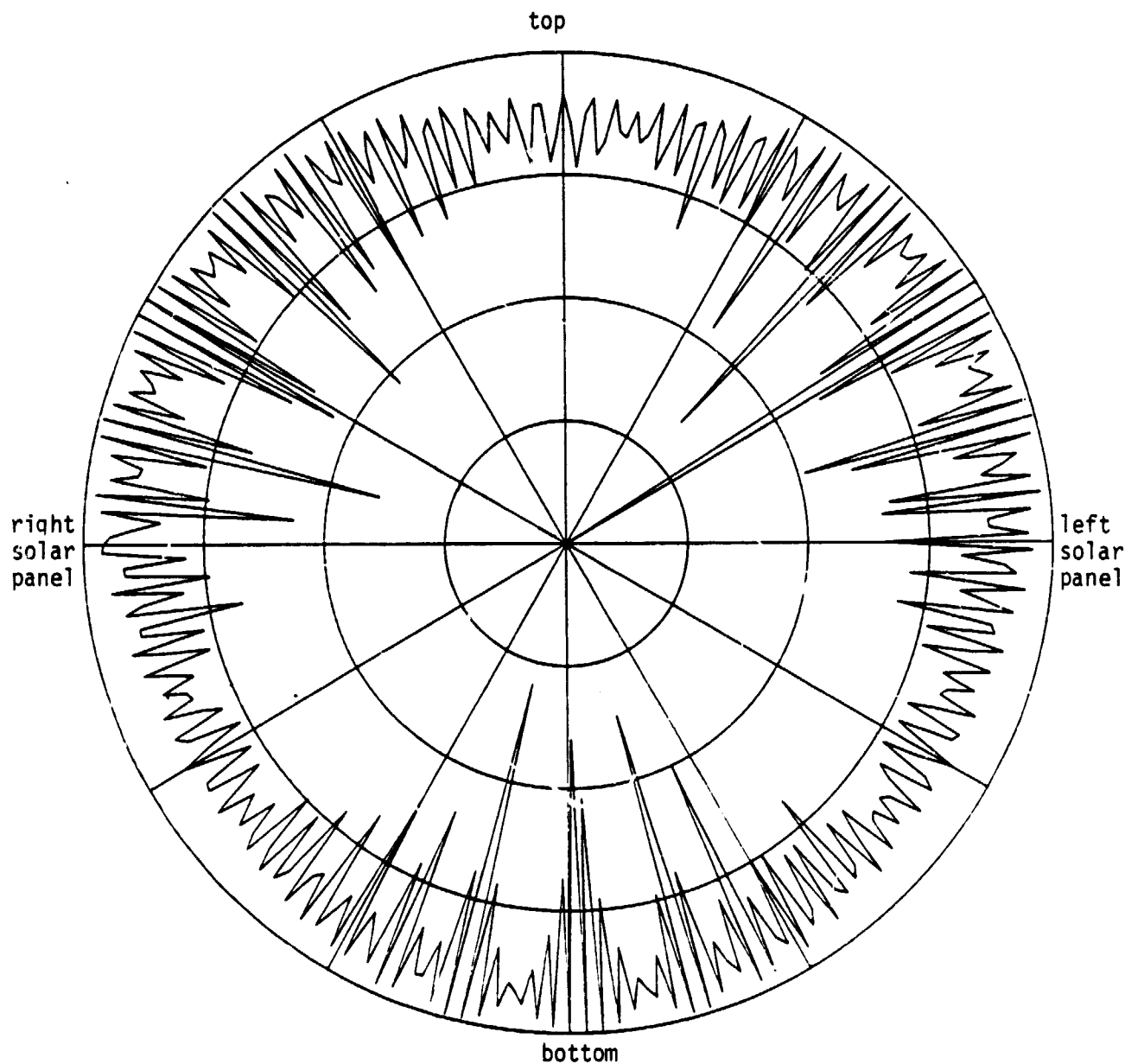

Figure III.3-29. Principal roll plane pattern at 2.2 GHz. Three axial slot antennas on top of each module.

ORIGINAL PAGES OF
OF POOR QUALITY

E-PHI
DB PLOT

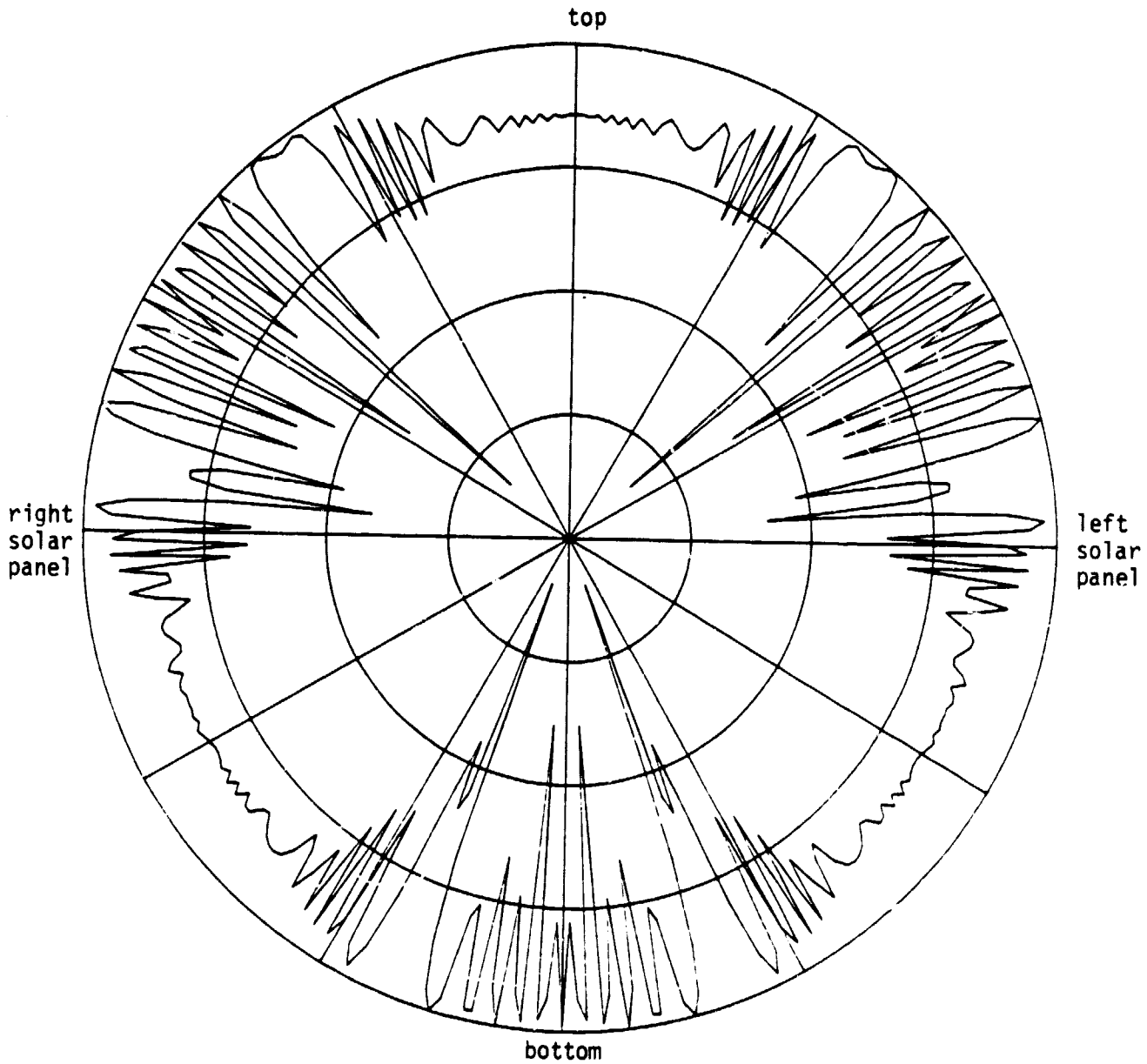

Figure III.3-30. Principal roll plane pattern at 25 GHz. Three axial slot antennas on top of each module.