

NASA
CP
2293
c.1

NASA Conference Publication 2293

Space Station Technology 1983

TECH LIBRARY KAFB, NM
0099248

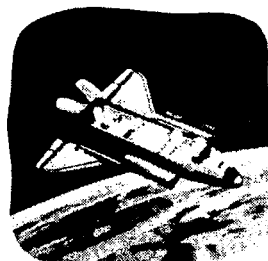
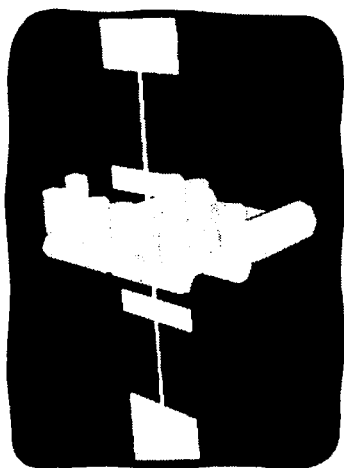

*Proceedings of the Space Station Technology workshop
held at the National Conference Center
Williamsburg, Virginia
March 28-31, 1983*

NASA

**LOAN COPY: RETURN TO
AFWL TECHNICAL LIBRARY
KIRTLAND AFB, N.M. 87117**



NASA Conference Pub.

Space Station Technology 1983

Edited by
Robert L. Wright and Cathy R. Mays
NASA Langley Research Center
Hampton, Virginia

Proceedings of the Space Station Technology workshop
held at the National Conference Center
Williamsburg, Virginia
March 28-31, 1983

NASA
National Aeronautics
and Space Administration
**Scientific and Technical
Information Branch**

1984



PREFACE

This publication is a compilation of the panel summaries presented at the Space Technology Workshop, which was held at the National Conference Center, Williamsburg, Virginia, March 28-31, 1983. The objective of the workshop was to aid the Space Station Technology Steering Committee in defining and implementing a technology development program to support the establishment of a permanent human presence in space. To achieve this end, the participants separated into 10 discipline-oriented panels which met for 2 days with the broad objective of converting NASA's planning into an integrated NASA-industry planning in each discipline area. This publication provides the summary reports of each of the 10 discipline panels, which were presented on the last day of the workshop. This compilation will provide the participants and their organizations with the information presented at this workshop in a referenceable format. This information will establish a stepping stone for users of space station technology to develop new technology and plan future tasks.

CONTENTS

PREFACE	iii
PARTICIPANTS	vii
SYSTEMS/OPERATIONS TECHNOLOGY Gordon R. Woodcock	1
CREW AND LIFE SUPPORT: EVA Richard S. Johnston	25
CREW AND LIFE SUPPORT: ECLSS George Drake	33
ATTITUDE, CONTROL, AND STABILIZATION B. G. Morais	41
HUMAN CAPABILITIES William Augerson	61
AUXILIARY PROPULSION Sanders D. Rosenberg	85
FLUID MANAGEMENT Dale Fester	89
COMMUNICATIONS G. J. Bonelle	95
STRUCTURES AND MECHANISMS David Purdy	109
DATA MANAGEMENT Glen Love	137
POWER Robert Corbett	155
THERMAL CONTROL Bob Haslett	165

PARTICIPANTS

GENERAL CO-CHAIRMEN

Dr. Walter B. Olstad
Associate Administrator for Management
Chairman, Space Station Technology Steering Committee

and

Dr. Jack L. Kerrebrock
Associate Administrator
for Aeronautics and Space Technology

TECHNICAL PROGRAM CO-CHAIRMEN

Richard F. Carlisle
Manager, Space Station Technology Office
Space Systems Division
NASA Headquarters

and

Paul F. Holloway
Director for Space
NASA Langley Research Center

PROGRAM COMMITTEE

Dr. William P. Raney	Ivan Bekey
Dr. Leonard A. Harris	Richard F. Carlisle
Dell P. Williams, III	Mark B. Nolan
NASA Headquarters	

TECHNICAL COORDINATOR

Simon V. Manson
NASA Headquarters

ADMINISTRATIVE CO-CHAIRMEN

Robert L. Wright	and	A. Gary Price
(804) 865-3666		(804) 865-3341
NASA Langley Research Center		

WORKSHOP PANEL CO-CHAIRMEN

DATA MANAGEMENT

William L. Swingle
NASA JSC

Charles F. Fuechsel
NASA Hq.

ATTITUDE, CONTROL AND STABILIZATION

Stephen Szirmay
JPL

Duncan B. McIver
NASA Hq.

COMMUNICATIONS

Richard M. Dickinson
JPL

Lee B. Holcomb
NASA Hq.

Dominick E. Santarpia
NASA Hq.

THERMAL

Wilbert E. Ellis
NASA JSC

Wayne R. Hudson
NASA Hq.

CREW AND LIFE SUPPORT

Walter W. Guy
NASA JSC

Dr. James H. Bredt
NASA Hq.

STRUCTURES AND MECHANISMS

Dr. Michael F. Card
NASA LaRC

Samuel L. Venneri
NASA Hq.

SYSTEMS/OPERATIONS TECHNOLOGY

W. Ray Hook
NASA LaRC

William T. Tumulty
NASA Hq.

AUXILIARY PROPULSION

Donald A. Petrash
NASA LeRC

Frank W. Stephenson, Jr
NASA Hq.

POWER

Jimmy L. Miller
NASA MSFC

Jerome P. Mullin
NASA Hq.

HUMAN CAPABILITIES

Alan B. Chambers
NASA ARC

Dr. Melvin D. Montemerlo
NASA Hq.

D. Bryant Cramer, MD
NASA Hq.

SYSTEMS/OPERATIONS TECHNOLOGY

Gordon R. Woodcock
Boeing Aerospace Company
Seattle, Washington

Space Station Technology Workshop
Williamsburg, Virginia
March 28-31, 1983

INTRODUCTION

The deliberations of the Systems/Operations Technology Panel are summarized herein for the participants of the Space Station Technology Workshop. To begin the deliberations, the first real question that arose was to develop an understanding of what systems/operations technology is. It is a relatively new discipline in the NASA technology organization, so it was necessary to define the objectives of technology from the start (fig. 1). Two objectives were established: (1) to make new things possible, and (2) to make existing capabilities cost less or work better. Making new things possible is not really applicable in the case of a space station. On a clear night, in the evening or in the morning, and at just the right time, a very bright object called Salyut 7 can be observed overhead. Both Salyut 7 and Skylab indicate that space stations are possible with existing (not necessarily new) technology. There was a concern on the part of some of the panelists that "work better" might mean higher performance, and that is not necessarily the case at all. "Work better" may mean simply to provide better service to the users of the space station at lower cost. The panel felt this to be a more realistic viewpoint. As evidenced from interaction with users (and all of the contractors found this basically to be true), the users want low cost, no schedule constraints, and no hassles.

OBJECTIVES OF TECHNOLOGY

TO MAKE NEW THINGS POSSIBLE - NOT APPLICABLE TO SPACE STATION

AND

TO MAKE OLD THINGS COST LESS OR WORK BETTER

Figure 1

COMPONENTS OF LIFE CYCLE COST

To gain some insight into lower costs, the concept of life cycle cost, as well as the life cycle of the cost, was explored. Life cycle costs (fig. 2) can be separated into five categories: (1) the design, development, test, and engineering; (2) the investment that is involved in getting a system in place and running after it has been developed (in a situation like the space station, that cost can be as large or larger than the DDT&E cost); (3) the operations cost, including the flight crews, the launcher, and the ground and flight processing; (4) support, which can be very expensive if the right job on autonomy and maintainability is not achieved; and (5) finally, the question of a decommissioning cost at the end of a program. It is obvious that cost over runout years can be very significant.

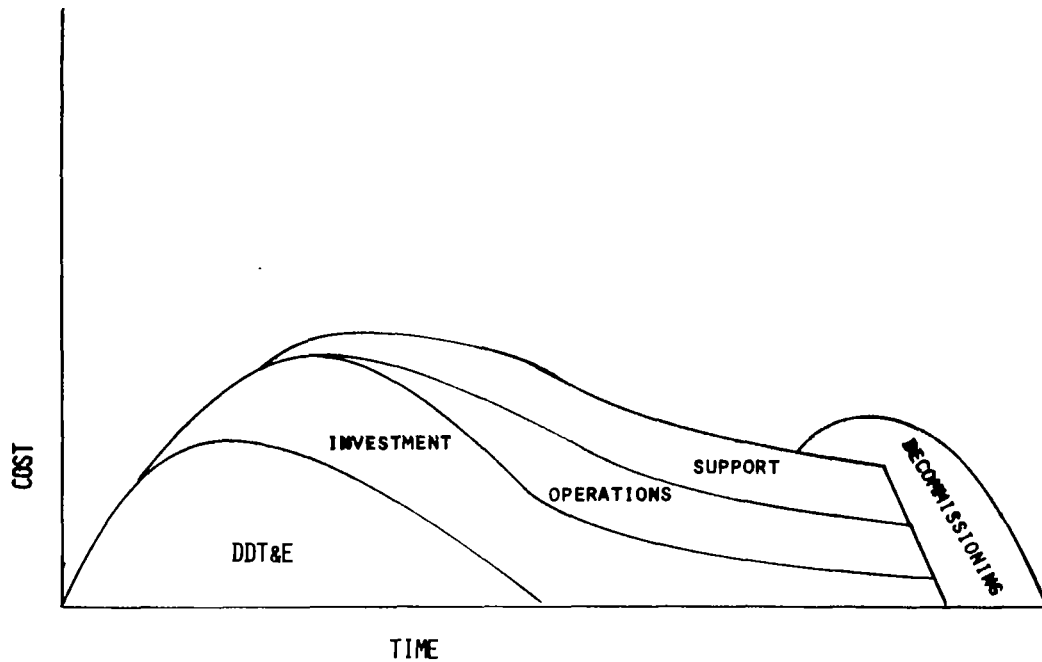

Figure 2

BARE-BONES PROGRAM

An example scenario of the cost breakdown of a bare-bones program is shown in figure 3. Hardware costs dominate during the early stages and disappear during the flight phase. The operations cost becomes the major factor during the flight operations phase of the program. The control of these runout costs will have a very strong influence on whether, in fact, the space station provides a net benefit.

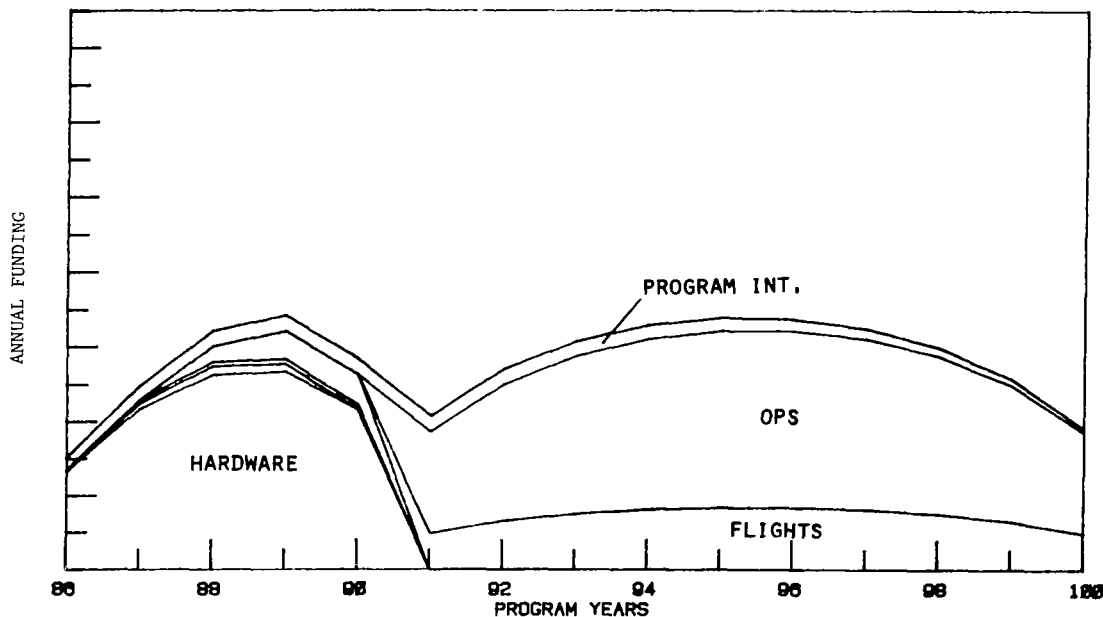

Figure 3

"WHAT IS SYSTEMS/OPERATIONS TECHNOLOGY?"

Getting back to the question of "What is systems/operations technology?" it is easier to discuss it from the standpoint of what it is not (fig. 4). It is not just right thinking, using common sense, or intelligence; neither is it systems engineering or simply normal design and development. Systems/operations technology generates specific technical advances which enable better and cheaper designs and documentation, safer and cheaper operations, and better service to the user at a lower cost.

IT ISN'T:

- HAVING ONE'S HEAD SCREWED ON STRAIGHT
- SYSTEMS ENGINEERING
- NORMAL DESIGN AND DEVELOP

IT IS, OR CAN BE

- TO DESIGN & ANALYZE BETTER OR CHEAPER
- TO DOCUMENT BETTER OR CHEAPER
- TO OPERATE BETTER OR CHEAPER OR SAFER
- TO PROVIDE BETTER SERVICE TO USERS AT LOWER COST

MANY TECHNOLOGY ADVANCEMENT NEEDS, ONCE IDENTIFIED BY SYSTEMS & OPERATIONS TECHNOLOGY ANALYSIS, BECOME SUBSYSTEMS TECHNOLOGY TASKS

Figure 4

SYSTEMS/OPERATIONS TECHNOLOGY WORKING GROUPS

Many of the technologies that were identified in the panel sessions, once they were identified, fell into the purview of some other technology panel. Actually, they fall into the category of a subsystem technology. Many of these technologies have been discussed before and were struggled with in earlier NASA meetings. In laying out a framework or agenda for the Systems/Operations Technology Panel (fig. 5), five working groups were formed. The output of these five working groups constitutes the balance of the panel report.

However, before addressing the output of the working groups, the subject of mission and technology relationship (architecture) was identified. The panel concluded that there is a very important broad overview item that needs to be addressed to deal with, understand, prioritize, and constructively guide the mission and technology relationships. Technology decisions cannot be made in a vacuum. Decisions relative to power may influence decisions relative to propulsion, which may, in turn, influence environmental and life support decisions, which may influence decisions on human capabilities, and so on. This is one of those situations in which almost everything influences everything else, and is being referred to as architecture.

SPACE AND GROUND ASSEMBLY, TEST, CHECKOUT, MAINTENANCE AND SAFETY

SYSTEMS ANALYSIS, SIMULATION AND MODELING

TECHNOLOGICAL GROWTH

SERVICING AND ON-ORBIT OPERATIONS

AUTOMATION AND AUTONOMY

MISSION AND TECHNOLOGY INTERRELATIONSHIPS (ARCHITECTURE)

Figure 5

SPACE AND GROUND ASSEMBLY AND TEST SUBPANEL

The critique of the Space and Ground Assembly and Test Subpanel (fig. 6) pointed out that although life cycle cost is important, it is not enough by itself. Clearly, the least costly life cycle program is the one that is not done. Life cycle cost has to be in the framework of providing a service to the user community.

There is concern over practical aspects of operational flow through a launch site. When discussing distributive architecture in a space station, all of the subsystems are found to be distributed. Hence, there will never be an event or place where you can test just the data management system, just the environmental control and life support system, or just the electrical power system. The only time to determine if these subsystems work is after the system has been assembled in space. It becomes necessary, therefore, to develop the capability of using sophisticated interface simulators and emulators to verify that each individual module of the space station is, in fact, functioning properly and interfacing with its partner modules in space.

The planning that was presented at the beginning of the workshop showed a deferral of some tasks affecting maintainability and reliability. It appears that deferral of these tasks was proposed because the tasks were not that well defined. The subpanel suggested that it was important to get the tasks defined and work initiated or the results would occur too late to do any good.

The maintenance objectives that were stated were a little nebulous. Specific quantified numerical objectives, in terms of remove-replace hours and mean time to repair, need to be defined.

FIGURE OF MERIT

LIFE CYCLE COST BY ITSELF IS INADEQUATE

SYSTEMS ARCHITECTURE

SUBSYSTEMS THEMSELVES ARE DISTRIBUTED - CAN'T TEST COMPLETE SUBSYSTEM IN ONE MODULE

TASK PHASING

DON'T DEFER MAINTAINABILITY, RELIABILITY, SAFETY, RESULTS TOO LATE

MAINTENANCE

OBJECTIVES THAT WERE STATED ARE TOO NEBULOUS. NEED SPECIFIC OBJECTIVES

Figure 6

RECOMMENDED TASKS

Recommended tasks in the systems/operations technology area are listed in figure 7. It is expected that some themes will be recurrent from the other subpanels. One task that should be highlighted is the area of computer-aided engineering, which is an extension of computer-aided design. This ranges from schemes for networking to some fairly ambitious ideas for actually applying artificial intelligence to computer-aided engineering.

1. IDENTIFICATION AND ASSESSMENT OF MAINTAINABILITY AND RELIABILITY CONSIDERATIONS RELATIVE TO CANDIDATE SUBSYSTEM TECHNOLOGY OPTIONS.
2. MANUFACTURING TECHNOLOGY CONSIDERATIONS RELATIVE TO CONCEPTUAL DEFINITIONS.
3. IDENTIFICATION OF TECHNOLOGY NEEDED TO IMPLEMENT A COMPUTERIZED ENGINEERING MODEL.
4. DEVELOPMENT OF TECHNIQUES TO ENABLE SPECIFICATION OF FORM, FIT AND FUNCTION CONSISTENT WITH THE CONCEPTS OF TECHNOLOGICAL TRANSPARENCY, COMMONALITY AND INTERCHANGEABILITY.
5. DEVELOP TECHNOLOGY FOR FUNCTIONALLY EQUIVALENT, USER FRIENDLY MISSION SPECIALISTS WORK STATIONS FOR GROUND AND ON-BOARD LOCATION.
6. DEVELOPMENT OF TECHNOLOGY TO ENABLE INTERCONNECTION OF INDIVIDUAL FIBER OPTIC BUSES AND ON-ORBIT REPAIR OF FIBER OPTIC CABLE.
7. DETERMINATION OF EFFECTS OF LONG TERM SPACE EXPOSURE ON INTERFACES, SUCH AS THOSE ASSOCIATED WITH P.C. BOARDS AND FLUID OR ELECTRICAL DISCONNECTS.

Figure 7

INDUSTRY COORDINATION

The panel felt that NASA had been missing the opportunity to benefit the space station program through industry cooperation and recommended continued NASA-industry coordination and cooperation, as outlined in figure 8.

OBSERVATION: UNTIL THE WILLIAMSBURG WORKSHOP, NASA HAS BEEN MISSING THE OPPORTUNITY TO BENEFIT THE SPACE STATION PROGRAM THROUGH INDUSTRY COOPERATION.

RECOMMENDATION: SET UP MECHANISM FOR CONTINUING NASA/INDUSTRY COORDINATION STARTED THIS WEEK. AS A MINIMUM:

- A. TRANSMIT UPDATED TECHNOLOGY PROGRAM PLANNING INFORMATION AND STATUS TO INDUSTRY DISTRIBUTION ON A REGULAR BASIS. INDUSTRY PROVIDE FEEDBACK AND RECOMMENDATIONS.
- B. WORK THROUGH IR²D PROGRAM TO INFORM INDUSTRY OF SS TECHNOLOGY NEEDS.
- C. STILL NEED PERIODIC FACE-TO-FACE MEETINGS.
- D. NEED TO CONSIDER INCLUDING USERS IN THE TECHNOLOGY COORDINATION ACTIVITY.

Figure 8

CRITIQUE OF EXISTING NASA TASKS

The Systems and Operations Subpanel critique of existing NASA tasks is shown in figure 9. For a technology systems analysis across disciplines (task 1), an operations model which recognizes the importance of operations (life cycle) costs is needed. The phased system and subsystem simulation/emulation task (task 2) requires an understanding of how to interface with subsystems and emulators to simulate and verify systems operation. Again, the architecture theme of not getting it all together in the same time and place for testing and checkout prior to orbit recurs.

- TASK 1: TECHNOLOGY SYSTEMS ANALYSIS ACROSS DISCIPLINES
 - NEEDS ADDITION OF OPERATIONS MODEL TO ACCESS EFFECTS ON LIFE CYCLE COSTS

- TASK 2: PHASED SYSTEM AND SUBSYSTEM SIMULATION/EMULATION
 - NOT ACTIVE BUT PARTIALLY COVERED BY AUTOMATION OF ECLS STUDY.
 - EMPHASIZE DEVELOPMENT OF ARCHITECTURE TO INTERFACE WITH OTHER SUBSYSTEM SIMULATORS/EMULATORS FOR SYSTEM LEVEL STUDIES.

Figure 9

CRITIQUE OF EXISTING NASA PROGRAM

In critiquing the program in general (fig. 10), the recurring theme of needing plans and architecture to tie together test beds and real-time man-in-the-loop simulations was presented. A scenario dealing with an operation involving the simultaneous simulation of Shuttle flight operations, teleoperator maneuvering system operations, EVA operations, and space station IVA operations was discussed. All of these operations may be taking place at different places and different times, and it is necessary to tie them together to get a true mission simulation.

Finally, the engineering data base must be improved by establishing an Agency-wide computer-aided engineering system, incorporating architecture, user interfaces, and user requirements.

- NEEDS PLAN & ARCHITECTURE TO TIE TOGETHER SUBSYSTEM TEST BEDS TO INVESTIGATE PERFORMANCE, AUTOMATION TECHNIQUES & TO VALIDATE SIMULATORS
- NEEDS PLAN & ARCHITECTURE TO TIE TOGETHER REAL TIME MAN-IN-LOOP SIMULATORS
- DEVELOP SYSTEM SIMULATORS THAT UTILIZE TEST BEDS/SIMULATORS
- IMPROVE ENGINEERING DATA BASE AS PROGRAM EVOLVES BY ESTABLISHING AN AGENCY WIDE COMPUTER AIDED ENGINEERING SYSTEM. DEFINE:
 - ARCHITECTURE
 - USER INTERFACES
 - USER REQUIREMENTS

Figure 10

RECOMMENDED TASKS

The recommended tasks from the Systems Analysis, Simulation, and Modeling Subpanel are listed in figure 11. Again, a thorough job of integrating the results of the various subpanels needs to be done to eliminate overlap. Although a few recurring situations exist, the following major themes come out strong: (1) computer-aided engineering, (2) simulation, (3) emulation, (4) understanding how to deal with a truly distributive system that is incrementally built in space, and (5) new technology, new ways of doing business.

ARCHITECTURE:

- ORGANIZE TOP LEVEL WORKING GROUP TO CONTROL ARCHITECTURE & GROWTH OF SIMULATORS & COMPUTER-AIDED SYSTEMS
- SYSTEMS ARCHITECTURE TO TIE TOGETHER MAN-IN-LOOP SIMULATORS
- SYSTEMS ARCHITECTURE TO TIE TOGETHER SUBSYSTEM TEST BEDS
- DEVELOP PROGRAM WIDE COMPUTER AIDED ENGINEERING TOOL

SIMULATORS:

- STRUCTURE AN APPROACH TO VERIFY AND CLASSIFY EXISTING SIMULATORS
- DEVELOP HIGH FIDELITY GRAPHICS SIMULATORS TO REDUCE NEED FOR MOCK-UPS
- DEVELOP HIGH SPEED USER FRIENDLY PARALLEL PROCESSORS AS A SIMULATOR TOOL
- DEVELOP TECHNIQUES TO VERIFY DYNAMIC SIMULATORS USED FOR MAN-IN-LOOP BERTHING, DOCKING AND CONTROL EVALUATIONS

DATA BASE:

- DEVELOP EVOLVING DATA BASE THAT USES ADVANCED S/W TOOLS

OPERATIONS:

- DEVELOP OPERATIONS MODEL TO ADD TO COMPUTER-AIDED ENGINEERING SYSTEM
- DEVELOP COMPUTER SYSTEM TO MINIMIZE DOCUMENTATION USED IN PROGRAM CONTROL & INTEGRATION

Figure 11

PRIORITY LIST OF TASKS

The prioritization of tasks for systems analysis, simulation, and modeling is shown in figure 12. Priority 1 tasks include establishing a data base and architecture of computer-aided engineering that is user friendly to multiple users and adding an operations model to the data base. Priority 2 tasks develop the architecture to couple test beds and man-in-the-loop simulators and the required high fidelity graphics simulation. Priority 3 tasks involve simulator verification and high-speed parallel processor techniques. Tying together simulation activities that deal with computer-aided imaging and real time requires communication between simulation elements involving very high data rates.

In computer-aided engineering (CAE), automated support for the development and automatic traceability of requirements becomes an issue. A change in the requirements somewhere in the requirements tree will immediately reflect what else is, or should be, affected by the change.

One issue surfaced but was not resolved. If all of these capabilities are tied together across the country so that data bases are accessible, how do you deal with the management issues that surface (i.e., management's desire to review what is in the data base before it is released to the world).

1. ESTABLISH DATA BASE AND ARCHITECTURE OF CAE THAT IS USER FRIENDLY TO MULTIPLE USERS.
 - REDUCE DUPLICATION OF EFFORT
 - REDUCE RISK OF USING WRONG DATA
 - MINIMIZE PROGRAM CONTROL & INTEGRATION DOCUMENTATION
1. ADD OPERATIONS MODEL TO DATA BASE.
 - ASSURES CONSIDERATION OF LIFE CYCLE COSTS
2. ESTABLISH ARCHITECTURE AND MEANS TO TIE TOGETHER TEST BEDS AND MAN-IN-LOOP SIMULATORS.
 - REDUCES DUPLICATION
 - REDUCED NEED FOR NEW FACILITIES
2. DEVELOP HIGH FIDELITY GRAPHICS SIMULATION PROGRAM.
 - REDUCES NEED FOR MOCK-UPS
3. DEVELOP TECHNIQUES TO VERIFY DYNAMIC SIMULATORS USED FOR MAN-IN-LOOP BERTHING, DOCKING AND CONTROL EVALUATIONS.
3. DEVELOP HIGH SPEED PARALLEL PROCESSOR TECHNIQUES WITH USER FRIENDLY COMPILERS FOR SIMULATORS & CAE ANALYTICAL TOOLS.

Figure 12

TECHNOLOGY GROWTH

In the subpanel meetings on technology growth, a number of interesting issues were addressed. Some major and/or prevalent views on technology growth are listed in figure 13.

- GENERAL AGREEMENT ON KEY QUESTION/SESSION OBJECTIVE AND TYPICAL ISSUES
- SOME MAJOR/PREVALENT THOUGHTS
 - LACK OF KNOWLEDGE OF FUTURISTIC REQUIREMENTS DOESN'T ALLOW MUCH "PROVIDING" IN THE INITIAL STATION
 - EVEN WITHOUT REQUIREMENTS - UTILITIES SHOULD BE DESIGNED FOR SOME TECHNICAL GROWTH CAPABILITY (INTELLIGENT OVERKILL)
 - SUBJECTIVE JUDGMENT LEANING TOWARD MODULE RETURNS TO GROUND FOR REFURBISHMENT AS MECHANISM FOR TECHNOLOGY GROWTH (TRADE STUDY MUST EVALUATE)
 - PAYLOADS/SPACE STATION SYSTEM/SUBSYSTEM MUST BE DESIGNED TO ACCEPT REFURBISHMENT

Figure 13

CRITIQUE OF EXISTING PROGRAMS

A critique of the existing programs (fig. 14) indicates the absence of any specific program aimed at technology growth. Technology growth capabilities have been evaluated in subsystem studies and there are precedents in the aircraft industry in which planning for growth is not uncommon and a great deal of growth does occur. However, it is important to distinguish between design for growth, design for technology advance, and design for technology innovation. For example, design for growth may simply mean adding more power or volume, or accepting more mission needs than anticipated at the outset of the program. Design for technology advance implies building newer and better systems that are functionally upward compatible and interchangeable (i.e., black boxes in the commercial data management industry). On the issue of designing for technological innovation, the panel ultimately concluded that it should not be attempted because no one knows how to do it.

- THERE IS NO EXPLICIT PROGRAM DIRECTED AT THE METHODOLOGY/IMPLEMENTATION OF TECHNOLOGY GROWTH

- TECHNOLOGICAL GROWTH CAPABILITIES EVALUATED IN SYSTEM STUDIES AND INFLUENCED BY OTHER PRECEDENCE; I.E., AIRCRAFT INDUSTRY

- MUST DISTINGUISH BETWEEN:
 - DESIGN FOR GROWTH (VOLUME, POWER, ETC.)
 - DESIGN FOR TECHNOLOGY ADVANCE (PRESENTLY KNOWN BUT TOO IMMATURE FOR FIRST VEHICLE)
 - DESIGN FOR TECHNOLOGICAL INNOVATION (PRESENTLY UNKNOWN)

Figure 14

KEY QUESTION AND TYPICAL ISSUES

The key question in technology growth is how the emerging technologies are recognized and incorporated into the initial program with minimal impact, especially since incorporation does not come free. Some typical issues are listed in figure 15. Do subsystems evolve or grow by replication, or are they replaced? The answer is probably "yes" to all of these. Do technology improvements save dollars, improve system capability, and provide better user service? What is the funding level, the front-end costs, required to build in the capability for growth? Frequently, programs are initiated with good intentions to provide for growth and technology advancement, but the bottom line is cost. Some item in the program must be traded out in order to include the cost of technology advancement, and that becomes a difficult management decision.

KEY QUESTION

- FOR A LONG-TERM SPACE STATION PROGRAM, HOW ARE EMERGING TECHNOLOGIES RECOGNIZED AND INCORPORATED INTO THE PROGRAM WITH MINIMUM IMPACT?

SOME TYPICAL ISSUES

- ARE SYSTEMS/SUBSYSTEMS EVOLVED, REPLICATED, REPLACED?
- ARE PROPOSED TECHNOLOGY IMPROVEMENTS PROJECTED TO SAVE DOLLARS, SATISFY REQUIREMENTS, BOTH?
- HOW TO ESTABLISH LONG-TERM REQUIREMENTS, MESH WITH TECHNOLOGY LEAD TIMES AND ESTABLISH APPROPRIATE FUNDING?
- CAN HIGHER PROGRAM FRONT-END COSTS BE TOLERATED TO BUILD IN CAPABILITY FOR TECHNOLOGY GROWTH?

Figure 15

TECHNOLOGY GROWTH OR STAGNATION

One issue that is always faced when dealing with new technology is that of technology advancement versus technology stagnation (fig. 16). The world of technologists works diligently toward technology advancement. In the program management situation, there is always the risk-avoidance motivation which tends to say "Use what's tried and true." When weighing the benefits of technology advancement, a percentage of the technology items will have had applicability beyond the immediate program, and this must be considered. Many technology areas, like data management initiatives and integrated hydrogen-oxygen systems, do not apply just to space stations. They apply to everything that is done in space.

So the key issue in technology growth is how to target growth and how to make it happen. This goes beyond just technology.

- O RISK AVOIDANCE MOTIVATES STAYING WITH "TRIED AND TRUE"
- O TECHNOLOGY ADVANCEMENT HAS BROAD APPLICABILITY
- O HOW DO WE TARGET GROWTH AND MAKE IT HAPPEN?

Figure 16

SYSTEM GOALS

The space station will require operational, integrational, and developmental "system goals" that will dictate architectural-cultural changes, since it is a different kind of system than any previously developed (fig. 17). Operationally, the space station will be reconfigured in orbit and the crew will assume a systems manager's role instead of simply an operator's role. Progressive automation will ensure flexible man/machine roles. Integration goals include procurement flexibility (particularly for high-cost items) and user-friendly and progressive checkout. Again, because the total system cannot be assembled and tested until it is in space, there is a requirement for smart assemblies.

OPERATIONAL:

- **IN ORBIT RECONFIGURATION . . . *Increased Facility Capability & User Demands***
- **BROAD CREW MODEL . . . *Systems Manager Not Operator***
- **TECHNOLOGY TRANSPARENCY . . . *Planned Incremental Upgrades***
- **FLEXIBLE MAN/MACHINE ROLES . . . *Progressive Automation***

INTEGRATION:

- **PROCUREMENT FLEXIBILITY . . . *Separate Modules & GFE for High \$ Items***
- **USER FRIENDLY . . . *Reduce Integration Cycle Time & Complexity***
- **STREAMLINED HW/SW VERIFICATION . . . *Decrease Facility & Time Req'd***
- **PROGRESSIVE CHECKOUT . . . *More Sell Off at Vendor, Less at Integrator***

DEVELOPMENT:

- **SMART ASSEMBLIES . . . *Local Control & Standard Interface***

Figure 17

TECHNOLOGY GROWTH RECOMMENDATIONS

Mission requirements and cost trades will dictate the implementation of designing for growth, technology advancement, and technological innovation (fig. 18). The panel recommended that the evolutionary space station concept be designed for growth, but that technology advances be selectively applied in critical areas and technological innovations not be included in the design. Military aircraft experience established a precedent that little or no growth is projected at the outset (due to funding). But the final hardware (growth article) is not physically the same piece of hardware as the original. It is a later version off the line. In the case of the space station, however, growth must be accommodated in the same physical piece of hardware that is in orbit.

MISSION REQUIREMENTS AND COST TRADES WILL DICTATE IMPLEMENTATION

- DESIGN FOR GROWTH - EVOLUTIONARY STATION CONCEPT

- DESIGN FOR TECHNOLOGY ADVANCE - SELECTIVELY APPLIED IN CRITICAL AREAS

- DESIGN FOR TECHNOLOGICAL INNOVATIONS - DO NOT INCLUDE IN STATION DESIGN

PRECEDENCE ESTABLISHED/TRENDS INDICATED FROM AIRCRAFT EXPERIENCE:

- MILITARY AIRCRAFT PROJECT LITTLE TO NO GROWTH IN ANY SERIES - DUE TO FUNDING

- PROCESS ACCOMMODATES TECHNOLOGY UPDATE AS MISSION REQUIREMENTS CHANGE

RECOMMENDATION: CONSIDER STUDY TO ESTABLISH THE SPACE STATION AND MISSION REQUIREMENTS SYSTEM/SUBSYSTEM TECHNOLOGY TRENDS OVER LONG TERM AS SYSTEM ENGINEERING TOOL.

Figure 18

SERVICE AND ON-ORBIT OPERATIONS CRITIQUE

The Service and On-Orbit Operations Subpanel reported the need to accelerate and increase the scope of the contamination task (fig. 19). Contamination is an important, user-critical, and multi-faceted issue with many kinds of problems. In addition to natural environment and induced environment contamination, there are many sources of contamination and effects that are not understood. The subpanel also recommended that spacecraft charging and plume impingement be added to the task, to attack the whole task as an integrated activity. Fluid and cryogenic transfer and cryogenic management tasks should be accelerated. The issue of zero-gravity transfer is very important and work needs to be accelerated. It is necessary that the impacts and where they fall be understood before real hardware is designed. On-orbit deployment and spacecraft final checkout need to be added, and the formation flying task should be deleted, since it is already understood (formation flying is flight mechanics, not technology).

- O ACCELERATE AND INCREASE SCOPE OF CONTAMINATION TASK
 - MOST IMPORTANT
 - FOLD IN CHARGING AND PLUME IMPINGEMENT
- O ACCELERATE FLUIDS AND CRYOGENICS TRANSFER
- O ADD ON-ORBIT DEPLOYMENTS AND FINAL CHECKOUT OF SPACECRAFT
- O DELETE FORMATION FLYING
 - ALREADY UNDERSTOOD - NOT TECHNOLOGY

Figure 19

SERVICING AND ON-ORBIT OPERATIONS PRIORITIES

The prioritization of tasks in servicing and on-orbit operations is listed in figure 20. Contamination is the most critical. On-orbit servicing, including both spacecraft servicing and servicing via propellant transfer, is second. The assessment of a logistics support vehicle and the orbital atmospheric-environment dynamics (which relates to contamination) complete the priority listing.

PRIORITIES

1. CONTAMINATION PREDICTION AND PROTECTION
2. ON-ORBIT SERVICING
3. SPACE STATION LOGISTICS SUPPORT VEHICLE ASSESSMENT
4. ORBITAL ATMOSPHERIC-ENVIRONMENT DYNAMICS

Figure 20

AUTOMATION/AUTONOMY

The Automation/Autonomy Subpanel recommended five areas for technology advancement (fig. 21). The first area involved the application of artificial intelligence and expert systems to spacecraft services and self management. Current artificial intelligence research emphasizes the development of self-modifying codes; that is, software that learns, modifies itself, and becomes smarter and better. Useful results are being obtained in this area and some expert systems have been built which do reasonably well. Some exploratory work is being conducted at NASA Kennedy Space Center on the application of expert systems to ground support operation (ground support automation). The real benefit of expert systems is to reduce the number of human experts needed to do a given job that requires human expert judgment. The human experts cannot be eliminated, but they can be made more productive. This is the recurring theme for development of automated design and analysis tools. [It is the personal view of the presenter that there is potentially a very large cost impact (cost savings) in this area, primarily because it is not understood and no one knows how to plan for it.] Since cost estimates tend, to some extent, to be self-fulfilling prophecies, it is important to understand the potential of this automated technology before the space station program costs are cast in concrete and budgeted. Robotics on the space station will be used for inspection, assembly, servicing, and repair. Here, robotics deals with true robotics (machine intelligence is applied and the robot is autonomous) and telepresence. (Communication techniques put man in the loop remotely in such an intimate fashion that he loses contact with where he really is and he feels that he is there and doing what his telepresence robot is doing.) Also, there is a need for technology advancement in automation to support simulation, evaluation, and training laboratories.

1. SPACECRAFT SERVICES SELF-MANAGEMENT -- A.I.
2. GROUND SUPPORT AUTOMATION
3. SPACE STATION ROBOTICS FOR INSPECTION, ASSEMBLY, SERVICING AND REPAIR, REFURBISHMENT AND ON-ORBIT EXPERIMENT INTERACTION.
4. PHYSICAL SIMULATION, EVALUATION, AND TRAINING LABORATORIES.

Figure 21

INDUSTRY COORDINATION

The Automation/Autonomy Subpanel observed that the NASA Office of Aeronautics and Space Technology has demonstrated a serious interest in automation technology and has had some impact on the evolution of automation technology, but current funding levels are inadequate (fig. 22). It was recommended that a Systems and Operations Working Group Subcommittee for Automation be established and that funding for advanced automation technology be increased.

OBSERVATIONS: NASA OAST HAS DEMONSTRATED A SERIOUS INTEREST
IN AUTOMATION TECHNOLOGY.
NASA HAS HAD SOME IMPACT ON THE EVOLUTION OF
AUTOMATION TECHNOLOGY.
CURRENT FUNDING LEVELS ARE INADEQUATE.

RECOMMENDATIONS: ESTABLISH A SYSTEMS AND OPERATIONS WORKING
GROUP SUBCOMMITTEE FOR AUTOMATION.
INCREASE FUNDING FOR ADVANCED AUTOMATION
TECHNOLOGY.

Figure 22

ISSUES FOR RESEARCH

The Systems and Operations Technology Panel concluded the working session with five issues for research (fig. 23). Understanding the issue of mission and technology relationships (the relationship of the technological architecture to the system operational architecture) will stimulate knowledge of how the technologies will interplay and how to prioritize the technologies across the board, make advances, incorporate the advances into the system, and realize the potential benefits.

In automation and autonomy, the issue is how, when, where, why, at what cost, and to what benefit are new concepts such as artificial intelligence, expert systems, and natural language packages going to be used. Will they be used in space, on the ground, in the design process, or across the board?

Key issues include (1) greater reliance on computer generated imagery and software data management types of simulations rather than on real physical simulation, (2) the ability to tie the flight and ground systems together to do integrated simulations of checkout procedures, and (3) emphasis on maintenance and repair activities. Engineering data base and standards issues include, for example, the real standards that should be applied to a space station for crew safety.

The computer-aided engineering systems analysis tools provide the possibility of tying everything together into some form of integrated network to take maximum advantage of benefits. This does not mean that human innovation and judgment will be replaced. Instead, the routine work that goes into the engineering and development process will be eliminated.

- o MISSION AND TECHNOLOGY INTERRELATIONSHIPS ("ARCHITECTURE")
- o AUTOMATION/AUTONOMY
- o SIMULATION - EMULATION
- o ENGINEERING DATABASE/STANDARDS
- o SYSTEM ANALYSIS TOOLS

Figure 23

CREW AND LIFE SUPPORT: EVA

Richard S. Johnston
Texas Medical Center, Incorporated
Houston, Texas

Space Station Technology Workshop
Williamsburg, Virginia
March 28-31, 1983

EVA SYSTEMS PANEL

The composition of the EVA Systems Panel is given in figure 1.

- 0 AEROSPACE CORPORATION
- 0 LOCKHEED MISSILES AND SPACE COMPANY
- 0 GENERAL ELECTRIC COMPANY
- 0 MARTIN MARIETTA AEROSPACE
- 0 HAMILTON-STANDARD CORPORATION
- 0 LIFE SUPPORT SYSTEMS, INC.
- 0 STANFORD RESEARCH INSTITUTE
- 0 ILC DOVER
- 0 USAF SCHOOL OF AVIATION MEDICINE

Figure 1

GENERAL RECOMMENDATIONS AND OBSERVATIONS

Four general recommendations by the EVA subpanel are listed in figure 2. There is a strong need for an EVA design standard document to be developed in the next year and updated as technology progresses. Too many times, questions are answered or problems solved in one program, but these are not documented and available to assist another program at a later time. The EVA design people need to develop a closer relationship (coupling) with the user community. For example, satellite and spacecraft designers need to develop a mutual understanding of the requirements for EVA crewmen as well as of how these requirements can be provided. Another concern was the seeming lack of centralized responsibility within NASA for EVA activities. Industry visits to different Centers and even within Centers indicated a lack of an EVA advocacy or total understanding of EVA problems. The current workshop and panel activity was very useful and, if continued, would serve to promote an exchange of information, and an understanding of user problems and to stimulate the technology area.

- 0 EVA DESIGN STANDARD DOCUMENT NEEDS TO BE DEVELOPED IN NEXT 6-12 MONTHS AND UPDATED AS TECHNOLOGY PROGRESSES
- 0 NASA NEEDS TO COUPLE EVA DESIGN PERSONNEL CLOSER TO USER COMMUNITY
- 0 THERE APPEARS TO BE A LACK OF CENTRALIZED NASA RESPONSIBILITY FOR THE EVA COMMUNITY
- 0 PANEL ACTIVITY SHOULD CONTINUE TO PROMOTE EXCHANGE OF INFORMATION AND UNDERSTANDING OF USER PROBLEMS, AND TO STIMULATE TECHNOLOGY ACTIVITY

Figure 2

EVA SYSTEMS PLAN SUMMARY

A quick summary of the technologies that NASA intends to pursue for the space station activity is listed in figure 3. The EVA design and operations criteria are a definition of the requirements that exist for the development of equipment, procedures, and operational activities. Space suit planning emphasizes the technology areas and the development of a higher mobility suit which would operate at a higher pressure and require the design of new joints and gloves. The existing space suits which are used in the Space Shuttle operate in a 1-atmosphere environment and require 3-1/2 hours preoxygenation prior to operation. This lag time imposes a hardship and a limitation on rapid operational support in going into EVA. One of the goals is to eliminate that problem. Some new innovative ideas include passive thermal protection for space suits. The outer covering of the Apollo EVA suits was a super-insulation coverall which provided passive thermal protection. There are limitations and problems in fabrication and durability of the material but some of the new concepts can greatly improve that. Head-up displays are being considered to make the EVA crewman's job easier by eliminating cue cards and normal aids which are now used. In-flight maintenance of space station suits must be built into the technology. (It is not feasible to return space suits to Houston for repair.) The portable life support system (PLSS) (or backpack) is a unit which provides O₂ and removes CO₂ and provides a liveable environment in space. Some of the features being considered in this technology include nonventing to preclude water vapor from being dumped into the cabin atmosphere and contaminating sensors or other equipment, and the reduction of expendables such as lithium-hydroxide cartridges, which are one-use items. Lithium hydroxide is used to absorb carbon dioxide to keep the CO₂ levels down. An alternate regenerative method of collecting CO₂ without the waste of 7 pounds of weight for each EVA is being investigated. Another aspect of the PLSS technology program involves extended duration, in-flight maintenance. In the manned maneuvering area, the current manned maneuvering unit (MMU) is limited somewhat in its range through operational constraints and a lack of operational experience. There is a need for improved guidance in the display to give an extended range capability within good sensible operational constraints. Also in the plan is integration of the display systems and overall integration of the extra-vehicular mobility unit (EMU), a combination of the suit and backpack. The last item in NASA's technology task is the EVA area of tools, work station, lighting, and other EVA aids. These are the necessary items when a crewman goes out to perform a construction task, make repairs, or carry out other useful functions. Certain of these items need to be developed and integrated into a system. With the extensive experience available at this workshop, the panel developed an overview of user requirements from a practical viewpoint.

- o EVA DESIGN & OPERATIONS CRITERIA
- o SPACE SUITS
- o PORTABLE LIFE SUPPORT SYSTEMS
- o MANNED MANEUVERING UNIT
- o EVA - WORK STATIONS, TOOLS, ETC.

Figure 3

RECOMMENDATIONS TO NASA TECHNOLOGY PLAN

The panel felt that the NASA plan was technically sound and took no exception to the priorities that were established (fig. 4). The order of priority was design criteria, EMU technology, MMU technology, and EVA tools and work stations. In fine-tuning the program content, the panel recommended two items for deletion, primarily because it had been demonstrated at this point that these technologies were needed. Recommended expansion of the program included plans for a second generation space unit, lighting, display integration for EMU and MMU, and crew EVA aids. The space station program is being designed for growth and the EVA and space suit areas are no different than other technology areas. The technology plan that NASA has developed will produce a suit for the first space station. However, it is easy to get trapped into the belief that this is the suit and it will last forever. In planning for a space station that will last for a decade, there are ideas in the wings which will give greater flexibility and performance capability, and the long-range plan should consider the next generation suit. Some additional subtasks were recommended, most of them studies. Relative to the question of atmospheric composition in the space station and the suit, NASA should establish a specification for each to stop the wasted effort in industry. Also, an airlock requirements and design study should be initiated. The committee strongly felt that there were some unique ideas and multipurposes which an airlock can perform other than the task of moving a person from a normal cabin atmosphere into the vacuum of space.

- o BASIC PLAN - TECHNICALLY SOUND
- o PROGRAM CONTENT - (FINE TUNING)
 - DELETION:
 - o EXOSKELETAL FORCE AMPLIFIER
 - o END ITEM EFFECTOR
 - EXPANDED SCOPE:
 - o PLANNING FOR SECOND GENERATION SPACE SUIT
 - o LIGHTING
 - o INTEGRATE EMU/MMU DISPLAYS
 - o CREW EVA AIDS
 - ADDITIONAL SUBTASKS:
 - o SPACE SUIT MATERIAL COMPATABILITY STUDY
 - o RADIATION ENVIRONMENT/PROTECTION STUDY
 - o SS/SPACE SUIT ATMOSPHERE
 - o AIRLOCK REQUIREMENTS & DESIGN STUDY

Figure 4

GENERAL COMMENTS ON TECHNOLOGY PLAN

The technology plan, as presented, was restricted to the space station. Consequently, it did not relate to today's problems, to the flow of development which has gone into the Shuttle program and to the experiences that will accrue as the Shuttle is operated (fig. 5). The plan for space station technology is not inadequate, but it needs a large range, more detailed plan. More emphasis should be placed on the opportunity to develop and evaluate EVA technology in the Space Shuttle missions. To build an arsenal of technology to move to the space station program, there will be many EVA opportunities on Shuttle flights which, on a noninterference basis, could be used to evaluate new tools, mobility aids, restraints, and lighting. In this way, after 6 or 7 years of operational flying in the Shuttle, many problems that can only be worked on in the space environment will be solved.

- o NASA EVA SYSTEMS TECHNOLOGY PLAN DID NOT INCLUDE NEAR TERM (SPACE SHUTTLE) TECHNOLOGY IMPLEMENTATION ACTIVITY. NOTE: INADQUATE TIME TO TRULY UNDERSTAND DETAILS OF PLAN.

- o MORE EMPHASIS SHOULD BE GIVEN TO THE OPPORTUNITY TO DEVELOP AND EVALUATE EVA TECHNOLOGY IN SPACE SHUTTLE MISSIONS.

Figure 5

RECOMMENDATIONS ON SCHEDULES

People in the industry feel that the schedules could and should be accelerated (fig. 6). Specifically, developmental work on the non-prebreathe rapid-don operational space suit (PSI suit) should be accelerated. The PSI suit is needed for the space station and, in time, will be needed for the Shuttle. PSI suit technology is in excellent shape. In fact, a prototype of a PSI suit is scheduled for delivery to NASA next month. Realistically though, the PSI suit is probably 2 years from being flight equipment. Also, work in the system design criteria/standards should be accelerated. There is a real need in the user community to truly understand the current capabilities for an EVA crewman. The manual should be maintained up to date to serve as a dynamic design/standards manual and be available to the user community (user friendly).

- o TECHNOLOGY SCHEDULES CAN AND SHOULD BE ACCELERATED:
 - RAPID DON/OPERATION SPACE SUIT DEVELOPMENT
SHOULD BE ACCELERATED -
 - NEEDED FOR SPACE STATION
 - NEEDED FOR SPACE SHUTTLE
 - TECHNOLOGY IN GOOD SHAPE
2 YEARS FROM FLIGHT EQUIPMENT

- o EVA SYSTEMS DESIGN CRITERIA/STANDARDS SHOULD BE ACCELERATED
 - o NEEDED BY SATELLITE DESIGNERS IN SPACE SHUTTLE

Figure 6

FUNDING RECOMMENDATIONS

In the area of funding, no one ever wants to say that there is enough money in the program (fig. 7). Funding for EVA criteria and EMU and MMU technology is considered to be marginally adequate. However, EVA support technology (tools, restraints, work stations) is underfunded. There was insufficient time or details to conduct an in depth cost review.

o PANEL FINDINGS

- FUNDING CONSIDERED MARGINALLY ADEQUATE FOR FOLLOWING TASKS:

- o EVA CRITERIA
- o EMU TECHNOLOGY
- o MMU TECHNOLOGY

- FUNDING CONSIDERED INADEQUATE

- o EVA SUPPORT TECHNOLOGY (TOOLS, RESTRAINTS, WORK STATIONS)

NOTE: PANEL DID NOT HAVE TIME OR SUFFICIENT DETAILS TO CONDUCT IN DEPTH COST REVIEW.

Figure 7

CREW AND LIFE SUPPORT: ECLSS

George Drake
General Dynamics
San Diego, California

Space Station Technology Workshop
Williamsburg, Virginia
March 28-31, 1983

LIFE SUPPORT WORKING PANEL

The Life Support Working Panel's critique of the NASA plan has provided insight into the near-term and long-term plans of NASA. The critique also provides NASA with the support, direction, and involvement of the technical community needed for a successful team effort to implement the plan. The panel representation is shown in figure 1. The membership of this panel involved the total spectrum, from prime contractors, who will be bidding on the space station, to component and subsystem manufacturers, research laboratories, and universities. A very spirited review of the plan was conducted, with a good interchange and many different viewpoints.

ADVANCED TECHNOLOGY, INC.
BATTELLE COLUMBUS LABORATORIES
BIONETICS CORPORATION
BOEING AEROSPACE
GENERAL DYNAMICS CORPORATION
GENERAL ELECTRIC
GEORGIA INSTITUTE OF TECHNOLOGY
GRUMMAN AEROSPACE CORPORATION
HAMILTON STANDARD
LIFE SYSTEMS, INC.
LOCKHEED MISSILES AND SPACE
McDONNELL DOUGLAS
MODAR, INC.
ROCKWELL INTERNATIONAL

Figure 1

LIFE SUPPORT PLAN

The theme of the NASA Life Support Plan is to provide both expendable and partially regenerative systems to support the first space station and to provide opportunities for growth beyond the initial space station. The plan was actually implemented in four basic parts (fig. 2). The technology demonstrator will be the focal point of the activity in the life support area. Currently, within the technology community, many subsystems and components are ready for phase C and D procurement. These particular items, along with the companion options, should be available and should be used in the demonstrator to determine problems with hardware and software interfaces, to explore man-machine interfaces, and to serve actually as a staging area for the activity in the development of the life support system for the space station. The plan also considers evolutionary growth technology. Whatever is designed today will become obsolete at some time in the future. Advancing technology, by its very nature, makes today's state-of-the-art designs the stepping stones to future developments. Current design decisions are predicated on providing an architectural configuration for life support systems that will allow, by selection, continual system updating. Evolution and growth will result not only in reduction in weight, but also in operational performance gains and enhancement of the habitability characteristics of the system. The broad aspects of how the life support system interplays with all the activity on the space station must be considered. It is necessary to keep the crew as fit as possible, so they can perform their operational assignments, effectively. Underlying all of this, of course, as in any technology, are the basic supporting research and technology requirements.

PLAN INCLUDES TECHNOLOGY FOR:

- 0 EXPENDABLE TO PARTIALLY REGENERATIVE SYSTEMS ON THE INITIAL SPACE STATION
- 0 SYSTEM GROWTH CAPABILITY OPTIONS

PLAN ELEMENTS:

- 0 TECHNOLOGY DEMONSTRATION
- 0 TECHNOLOGY OPTIONS
- 0 EVOLUTIONARY GROWTH TECHNOLOGY
- 0 SUPPORTING RESEARCH AND TECHNOLOGY

Figure 2

REGENERATIVE SYSTEMS

The use of regenerative systems in the first space station can provide an early payback of the funds associated with their development (fig. 3). With regenerative systems, the resupply requirement will be reduced. This will, in turn, reduce the ground operations associated with resupply and logistics. By initially establishing a regenerative system and thereby setting the architecture of the space station, an open capability to an orderly advance of the technology will be maintained. Thus, the increasing demands of larger crews and more complex mission-oriented tasks will be satisfied. As an example, consider the life cycle cost benefits of closing a water loop for a hypothetical mission scenario of a space station with a crew of eight. Each of these eight people would require about 50 pounds of water a day for drinking, bathing, laundry, and hygiene. In comparing the cost of the regenerative water recovery system with direct resupply of water every 90 days, a savings of \$1.2 billion would be achieved over a 10-year period. The regenerative system can also provide an early payback by focusing industry support through appropriate use of independent research and development (IR&D) funds. Currently, some NASA managers assume that if NASA takes care of selected areas of research, then industry will spend its IR&D funds in other areas. In reality, industry determines in which direction NASA research is going and spends its IR&D funds there. These are the high-priority items and industry funds them to become more competitive. The NASA support of regenerative systems not only provides monetary support, but also helps maintain a cadre of people who have been working in this area for 20 years. These people have the experience, understand the problem, and want to work on the problem. It is important that this capability be retained as a national resource.

REGENERATIVE SYSTEM EARLY PAYBACK:

- 0 REDUCED RESUPPLY
- 0 REDUCED GROUND OPERATIONS
- 0 ORDERLY TECHNOLOGY PROGRESSION
- 0 INCREASES CREW EFFICIENCY/COMFORT

- 0 CREW HABITABILITY IMPROVEMENT
- 0 REDUCE RESUPPLY HANDLING
- 0 FOCUSES INDUSTRY SUPPORT
- 0 I R & D
- 0 TECHNOLOGY RETENTION

Figure 3

SCHEDULE

The schedule (fig. 4) that NASA has proposed has four main elements. The focal point of all the life support activity is the demonstrator for the initial space station. The demonstrator is composed of items that are ready for Phase C and D development. Technical options are scheduled during the early years to provide alternatives because the capability to substitute must be maintained. Growth technology and supporting research and technology (SR&T) will continue throughout the program life, and as new items emerge, the space station capability will be updated.

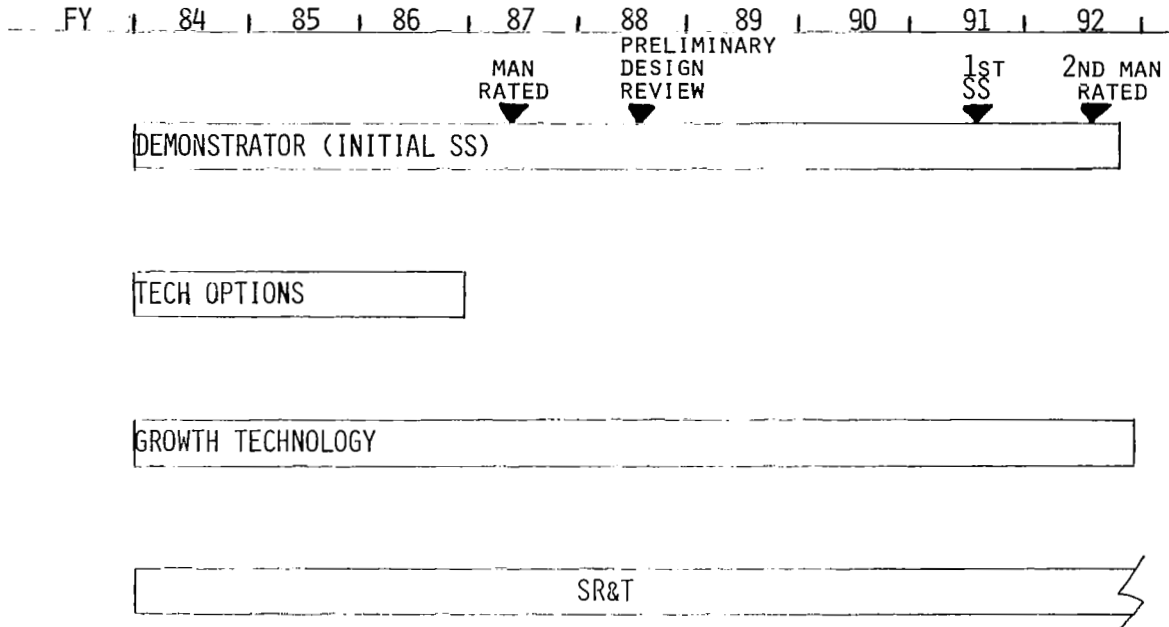

Figure 4

FUNDING

The funding (fig. 5) was divided into two groups, the enabling technology of the first 4 years and the 4 growth years beginning in F.Y. 1988. Funding for the enabling technology was \$41 million and funding for the growth was \$48 million. In general, the panel felt that the funding was marginally adequate, and that the early enabling technology should be more heavily funded to get started.

FUNDING (THOUSANDS OF DOLLARS)

ENABLING TECHNOLOGY				GROWTH			
FY84	FY85	FY86	FY87	FY88	FY89	FY90	FY91
6800	11050	12200	13050	12650	11850	11800	12300

Figure 5

REVISIONS

The panel's review of the plan (fig. 6) indicated that although no technologies were overlooked, some priorities should be changed. In the 90-day resupply of a space station, there is considerable concern that trace gas control could become a serious problem. With the crew in a closed environment continuously for 90 days, they will not have the opportunity to naturally purge their system of contaminants, as is permitted with shorter mission durations. It is quite important that contaminant control be one of the early equipment items in the demonstrator. The recent Shuttle flights have shown that management of waste (unused portions of food, the liquids and paper associated with flight experiments, and other trash) has become a significant problem. Waste disposal is obviously going to be a much more serious problem in the early space station because of extended mission durations. A new development that will be needed is a laundry. There has never been a need for a laundry in space, but if extended missions are going to occur, clean clothes are going to be a necessity. Everyone recognizes that flight testing of components is important but expensive. In reviewing the planned flight testing, the panel consensus was that some components did not require flight testing (zero gravity sensitivity was not that critical) and the scope of the planned flight testing could be decreased.

INCREASED PRIORITY

- 0 TRACE GAS CONTROL
- 0 SOLID WASTE/TRASH MANAGEMENT
- 0 LAUNDRY

DECREASED SCOPE

- 0 FLIGHT EXPERIMENTS

Figure 6

SUMMARY

In summary (fig. 7), the panel felt the regenerative system technology that NASA has developed and maintained over the last several years is ready to be utilized in selected areas on the first space station. The program as defined by NASA with options and growth capability will support the overall activity and various scenarios for the space station in its growth approaches. The plan represents a life cycle cost savings (for example, in water cost alone, a \$1.2 billion savings over a 10-year period). The funding is adequate but, because of the unknowns in any development activity, more funding in the beginning is suggested. The schedule is realistic and would allow NASA to meet the goals and demands of the space station for the flights in 1991 and 1992.

GENERAL AGREEMENT WITH NASA PLAN

- O LIFE SUPPORT TECHNOLOGY CAN BE READY TO UTILIZE
SELECTED REGENERATIVE SYSTEMS ON THE INITIAL
SPACE STATION
- O THE PLAN REPRESENTS A MAJOR LIFE CYCLE COST SAVING
- O SUGGESTED FUNDING BY NASA IS ADEQUATE
- O SCHEDULE IS REALISTIC

Figure 7

ATTITUDE, CONTROL, AND STABILIZATION

B. G. Morais
Lockheed Missiles and Space Company
Sunnyvale, California

Space Station Technology Workshop
Williamsburg, Virginia
March 28-31, 1983

INTRODUCTION

In the area of control, several problems can arise during the evolution of the space station. These include: 1) the use of multiple or articulated flexible bodies; 2) the need for distributed control for maneuvering and maintaining altitude; 3) hierarchical control to automate and manage control systems; 4) structural control (from the standpoint of appendage stamping, isolation, and possible figure control; 5) control position and orientation for component modules during construction (an evolutionary requirement); 6) control during docking and undocking operations; and 7) the normal requirements for stability and control during systems operations. In addition, there are a number of key technology concerns, such as significant landing modes which tend to be closely spaced and distributed widely, distributed sensors and actuators which may be collocated, and the wide distribution of landing modes that must be reduced from a dimensional standpoint. The design of the control system must account for time-varying dynamics, non-linearities, inaccurately known model characteristics, controller effects, and, from a survivability or full-tolerance standpoint, undetected sensor and actuator figures. One other key point was the fact that current technology does not permit accurate modeling of the on-orbit structural behavior either from an analytical standpoint or from a derivation from ground test information.

TECHNOLOGY READINESS REQUIREMENTS

The guidance and control technology readiness requirements tend to flow as depicted in figure 1. Here, a single module is defined as a rigid system.

The control point is that the initial space station will have to be handled with current analytical techniques. As the space station evolves from the single to the multiple module (or a more flexible body space station), additional technologies need to be developed. They do not have to be fully developed, but it will require particular emphasis to get them to a point where they can handle the more flexible bodies. Moving toward a more advanced space station (defined here as multimodule, multiplatform), more complex technologies such as coupling theory, control architecture, and vibration isolation will come into play to handle the more flexible space station. These technologies are in addition to the multiple module technologies.

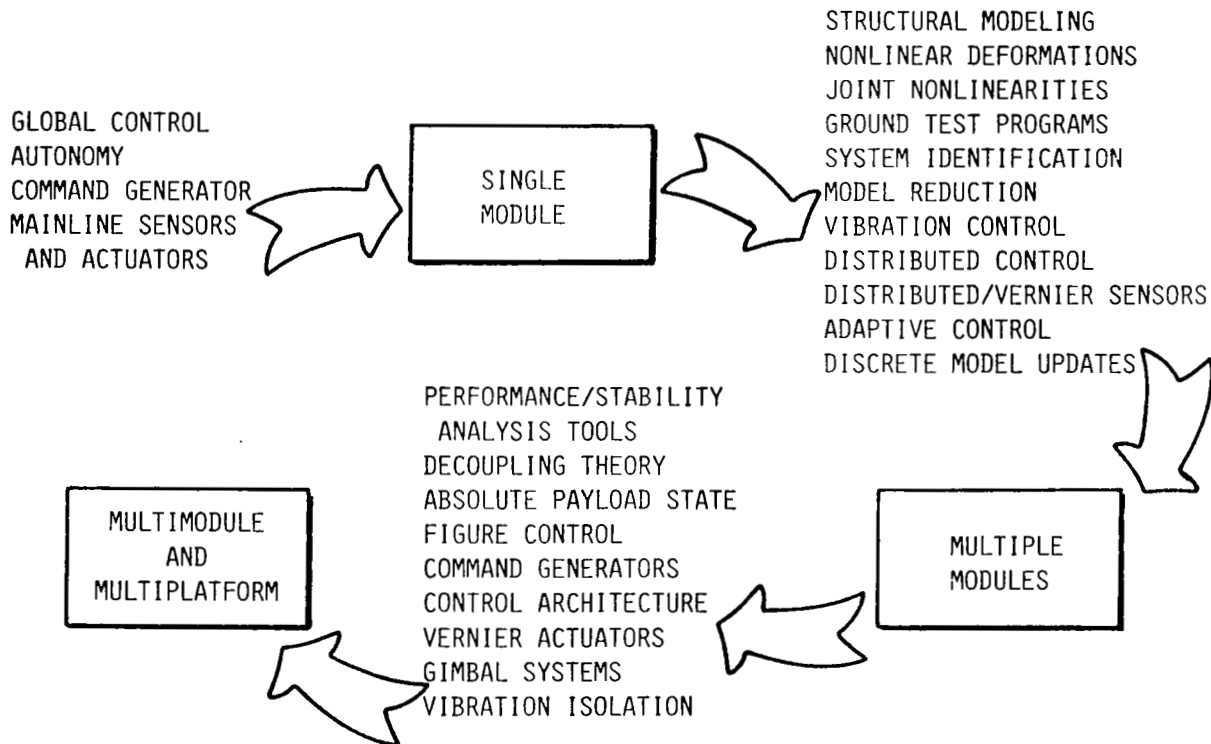

Figure 1

CURRENT TECHNOLOGY AND READINESS

Current guidance and control technology that would support the needs for the initial space station has been identified and the technology readiness status has been assigned (fig. 2). A readiness level of one indicates that the basic principles have been observed, and a readiness level of eight indicates that the technique is in use (has been flown) or is very close to being in use. The readiness levels provide an indication of what has to be done to improve that technology to at least support the initial space station.

	<u>READINESS LEVEL</u>
● DISTRIBUTED DATA PROCESSING ARCHITECTURE	1
● CONTROL & IDENTIFICATION THEORY & REDUCTION TO PRACTICE	3
● HARDWARE COMPONENTS:	
● MOMENTUM STORAGE	4-5
● OTHERS	6-8
● ANALYSIS & SYNTHESIS TOOLS	2
● SUBSYSTEM & SS AUTONOMY & INTEGRATION	4
● DESIGN VERIFICATION PROCESS - TESTING PHILOSOPHY	4
● PAYLOAD POINTING	5-6
● GUIDANCE & NAVIGATION	6
● MOMENTUM MANAGEMENT	2
● MANIPULATOR DEVICES	5

Figure 2

SPACE STATION GUIDANCE, NAVIGATION, AND CONTROL TECHNOLOGY NEEDS

The guidance, navigation, and control technology needs for the space station are listed in figure 3. Recognizing that the space station is going to be evolutionary, ground work must now be laid for all of the guidance, navigation, and control items that are required. The technology is very close at hand for supporting a simple space station (one that can be treated from a rigid-body standpoint). The technology falls short in the evolution to the multiplatform space station. Each of the eight technologies is presented individually with the need indicated and the timing (phase relationship) shown graphically (figs. 4 to 11).

1. DATA PROCESSING ARCHITECTURE
2. CONTROL & IDENTIFICATION THEORY AND REDUCTION TO PRACTICE
3. HARDWARE COMPONENTS
4. ANALYSIS & SYNTHESIS TOOLS
5. SUBSYSTEM AND SPACE STATION AUTONOMY AND INTEGRATION
6. DESIGN VERIFICATION PROCESS
7. PAYLOAD POINTING
8. GUIDANCE AND NAVIGATION

Figure 3

DATA PROCESSING

In the data processing area, the needs are somewhat obvious (fig. 4). Software will be needed, as will growth capability, both from a technology and a configuration standpoint. As the physical plant grows, guidance, navigation, and control data processing for docking-undocking, fueling, and return of spacecraft for refurbishment and repair will increase. Another key area is the methodology for software verification, particularly involving space station modifications and the use of multi-module, multi-platform stations. The need is high, as shown, and the time phasing indicates that the work should start now.

NEEDS:

- ALGORITHM DRIVEN ARCHITECTURE
- GROWTH CAPABILITY
- HARDWARE AND COMPUTER COMMUNICATION
 - COMPUTER TO COMPUTER HAND SHAKING
 - SUBSYSTEM TO SUBSYSTEM COMMUNICATION OF CONTROL INFORMATION
 - COMMUNICATION WITHIN SUBSYSTEMS
- VERIFICATION METHODOLOGY
- CONTROL ORIENTED HIGHER LEVEL LANGUAGES

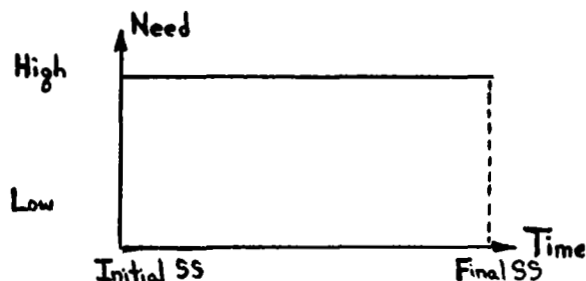

Figure 4

CONTROL AND IDENTIFICATION THEORY AND REDUCTION

To put the control and system identification theory into practice, various modeling techniques need to be developed for the large space structures (fig. 5). There will be a need for controls that adapt to the structural dynamics, mass changes, and consumables that will be aboard the space station. Vibration and figure control will be needed for large space structures, not just the space station. Since the space station will be in low-Earth orbit, thrust vector control and drag makeup will be necessary. These characteristics will change as the space station configuration evolves. The technology need is high for those items that are not large structure related; a growth curve is shown for the evolution from an initial space station to a final space station. (Defining a final space station is problematical at this time.)

NEEDS:

- IDENTIFICATION AND MODELING TECHNIQUES FOR LSS.
- CONTROLS THAT ADAPT TO STRUCTURAL DYNAMICS, ARTICULATION, MASS CHANGES, AND CONSUMABLES.
- VIBRATION AND FIGURE CONTROL FOR LSS.
- THE ABILITY TO TRADE OFF CONTROLS VS. STRUCTURAL SOLUTIONS.
- DISTRIBUTED CONTROL.
- THRUST VECTOR CONTROL.

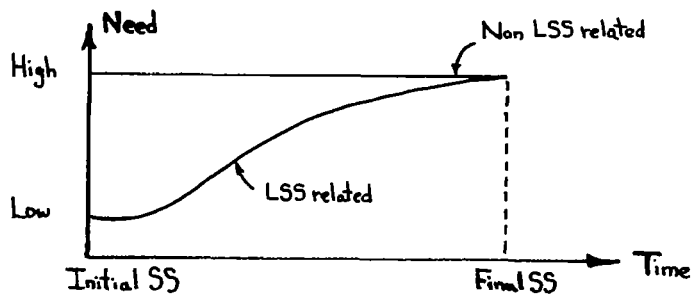

Figure 5

HARDWARE COMPONENTS

From a hardware standpoint, the needs (fig. 6) are in the areas of sensors to support docking and "smart" components. The interfaces between hardware and those between the controllers and the on-board processing equipment must be standardized to support the guidance, navigation, and control technological evolution of the space station. "Clean" thrusters are required for optical payloads. Control moment gyros, integrated power and storage for attitude control, and even flywheels (which can now provide power as well as momentum to correct attitude) will be needed in the guidance, navigation, and control subsystem. The assessment of the time phasing shows a low need for the initial station but a high need for the later versions.

NEEDS:

- AUTODOCKING SENSORS
- RELATIVE ALIGNMENT SENSORS
- "SMART" COMPONENTS
- VIBRATION & FIGURE CONTROL HARDWARE
- "CLEAN" THRUSTERS
- GIMBAL SYSTEMS
- CMG'S & INTEGRATED
POWER AND STORAGE

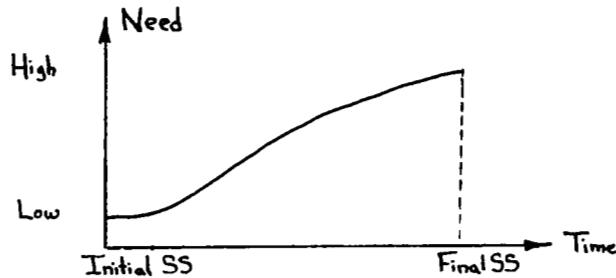

Figure 6

ANALYSIS AND SYNTHESIS TOOLS

The guidance, navigation, and control technology requires analysis and synthesis tools to analyze the performance of the thermal and controls systems and to integrate the controls and the structure. These required tools are listed in figure 7. The time phasing of the tools shows a moderate need for the initial space station and a strong need for the final station.

- DESIGN OF HIGH ORDER MULTI INPUT / OUTPUT CONTROL SYSTEMS
- NONLINEAR STRUCTURAL MODELS AND STRUCTURE SYNTHESIS.
- CAD OF CONTROL SYSTEMS.
- NUMERICAL TECHNIQUES.
- METHODS FOR PAYLOAD COMMAND/TRACKING.

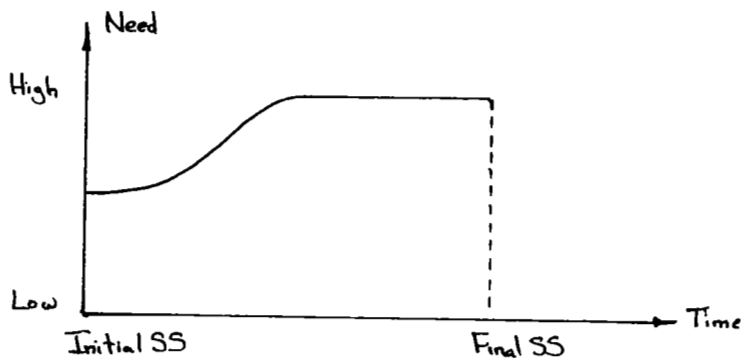

Figure 7

SUBSYSTEM AND SPACE STATION AUTONOMY

The space station control and the control of the various appendages need to be autonomous (fig. 8). This implies self-contained failure detection and isolation (including built-in testing). Work needs to be done to characterize failures, develop decision-making criteria regarding the reconfiguration schemes that should be followed to support on-orbit repair by the crew and develop a computer-aided problem solving capability. The last item, artificial intelligence, was listed with mixed feeling among the panel members. Some skeptics resisted or were reluctant to list artificial intelligence because they were not sure of the direction that artificial intelligence is taking. One key point was that a great deal of money is being spent on artificial intelligence, but the most significant studies are being made in unfunded programs. The time phasing shows that the needs are light for all space stations planned.

NEEDS:

- FORMALISM FOR AUTONOMOUS TESTING
- FAILURE DETECTION, IDENTIFICATION AND RECONFIGURATION
- COMPUTER AIDED PROBLEM SOLVING
- ARTIFICIAL INTELLIGENCE

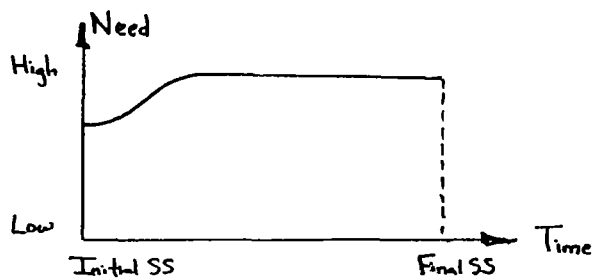

Figure 8

DESIGN VERIFICATION PROCESS

The design verification process poses a great problem to the guidance, navigation, and control technology because there is no current method to test a large space structure or integrated guidance, navigation, and control system before launch (fig. 9). An appreciation of how to extrapolate from ground test to the space environment needs to be developed. Also, to generate a scheme for better model validation, flight test experiments that will begin validating the analytical tools need to be designed. Likewise, a flight testing philosophy for the space station needs to be initiated. This philosophy needs to include not only in-flight testing on the early space station flights, but also the in-flight testing that can be accomplished now with the Shuttle and can later be transferred to large space structures.

NEEDS:

- AN APPRECIATION OF HOW GROUND TEST DATA CAN BE EXTRAPOLATED TO SPACE ENVIRONMENT.
- MODEL VALIDATION (COMPUTER TOOL VERIFICATION)
- INCREMENTAL VERIFICATION
- A FLIGHT TEST EXPERIMENT
- IN FLIGHT TESTING PHILOSOPHY FOR SPACE STATION

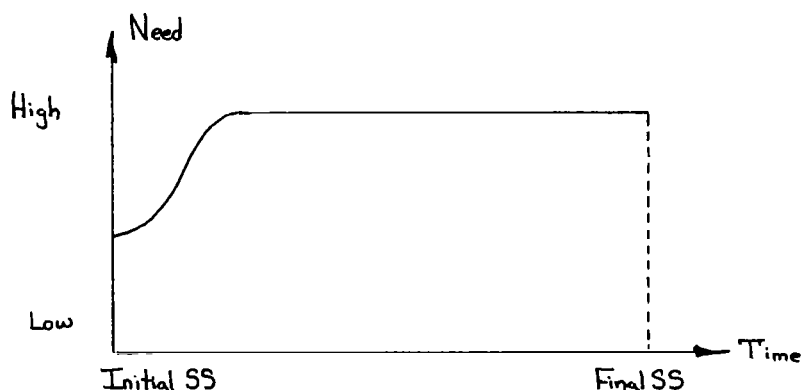

Figure 9

PAYLOAD POINTING

Payloads, and some of the station appendages, may be articulated using active control systems (fig. 10). Some missions may have several payloads, all of which may have independent pointing requirements. Disturbance isolation and decoupling, development of gimbal systems, and stationkeeping schemes may be payload dependent. The phasing is dependent on the initial missions for the space stations.

NEEDS:

- DISTURBANCE ISOLATION AND DECOUPLING
- COMMAND GENERATORS (FEED FORWARD CONTROL)
- GIMBAL SYSTEMS
- MULTIRATE SAMPLED DATA CONTROL
- STATION KEEPING

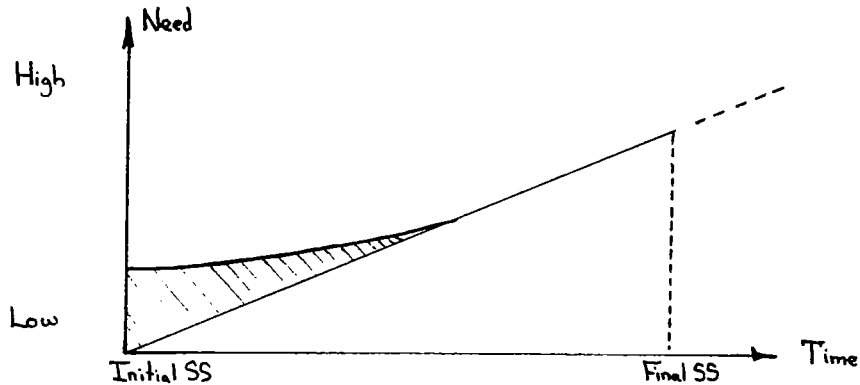

Figure 10

NAVIGATION

The space station requires autonomous navigation (fig. 11). With Shuttle revisits and formation flying, traffic control and stationkeeping will impose navigational requirements. And, of course, disposal of the station at the end of its life may be a consideration.

NEEDS:

- AUTO NAVIGATION
- TRAFFIC CONTROL
- STATION KEEPING
- RE & DE BOOST

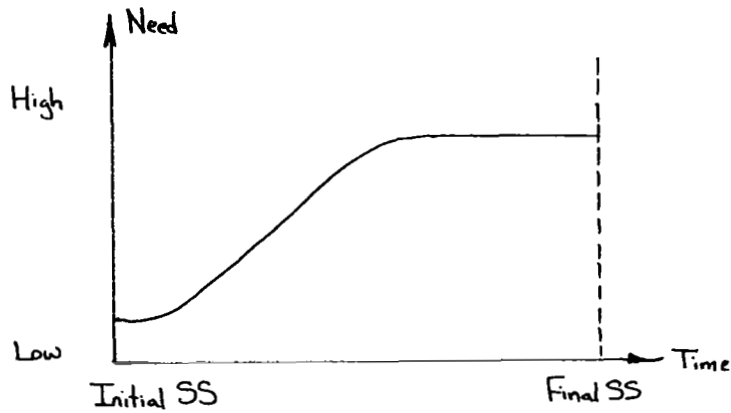

Figure 11

GUIDANCE, NAVIGATION, AND CONTROL TECHNOLOGY DEVELOPMENT CRITERIA

The panel developed a list of technology tasks in each area that must be undertaken to satisfy the guidance, navigation, and control requirement of both an initial and a future space station. The criteria that were used to establish the technology tasks are listed in figure 12.

- o CRITERIA OF PRIORITIZATION
 - PERCEIVED CRITICALITY
 - TIME-PHASED NEED
 - PAYOFF
 - NOT ALREADY SPONSORED

Figure 12

**GUIDANCE, NAVIGATION, AND CONTROL TECHNOLOGY DEVELOPMENT CANDIDATES:
Synthesis/Analysis/Simulation**

Candidate synthesis, analysis, and simulation tasks include operational planning and traffic management, manipulator control, structural dynamic control, and attitude control (fig. 13). Of these, the development of attitude control technology is required for the initial space station to provide modeling and identification of the structure, momentum management, and modular and adaptive control. The development of the other technologies is required for future space stations.

- | | |
|--|--|
| o OPERATIONAL PLANNING AND TRAFFIC MANAGEMENT SYSTEM | PROVIDES INTER-VEHICLE AND TRAFFIC CONTROL, ALLOWS SAFE TERMINAL RENDEZVOUS & DOCKING |
| o MANIPULATOR CONTROL | ENABLES OPERATIONS, EASES OPERATOR TASKS |
| o STRUCTURAL DYNAMICS CONTROL | IMPROVES PERFORMANCE FOR FLEXIBLE VEHICLE, PROVIDES STABILITY, DAMPING, SHAPE CONTROL |
| o ATTITUDE CONTROL | MODELING AND IDENTIFICATION OF STRUCTURE, MOMENTUM MANAGEMENT, MODULAR CONTROL, ADAPTIVE CONTROL |

Figure 13

**GUIDANCE, NAVIGATION, AND CONTROL TECHNOLOGY DEVELOPMENT CANDIDATES:
Hardware/Components**

Hardware and components tasks are listed in figure 14. The development of docking sensor, interface, and pointing moment technology is required initially. Development of pointing mounts may relieve some of the initial space station requirements (provide torquing equilibrium orientation). If the initial missions or initial requirements from the payload users dictate, isolation devices may be needed for the early space stations.

- | | |
|---|---|
| o IMPROVED CMG | LOWER COST, LONGER LIFE, IMPROVED MOMENTUM DENSITY |
| o DOCKING SENSOR/ INTERFACE | SAFETY, OPERABILITY |
| o ADVANCED RELATIVE NAVIGATION SENSOR | TRAFFIC MANAGEMENT, EXTENDED RANGE, MINIMIZE VEHICLE CONSTRAINTS, PROPELLANT REDUCTION |
| o ATTITUDE TRANSFER DEVICES | IMPROVED EXPERIMENT POINTING, ALLOWS CENTRALIZED ATTITUDE DETERMINATION |
| o INTEGRATED ENERGY/ MOMENTUM MANAGEMENT SYSTEM | WEIGHT SAVINGS |
| o POINTING MOUNTS | FACILITATES EXPERIMENT POINTING, RELIEVES SS POINTING REQUIREMENTS, ALLOWS PAYLOAD VIEWING/POINTING, IMPROVES PERFORMANCE |
| o ISOLATION DEVICES | IMPROVES EXPERIMENT PERFORMANCE |
| o AUTONOMY | PROVIDES SAFETY, OPERATIONAL ENHANCEMENT, COST |
| o ON-BOARD NAVIGATION | SAFETY, COST |

Figure 14

**GUIDANCE, NAVIGATION, AND CONTROL TECHNOLOGY DEVELOPMENT CANDIDATES:
Design Verification**

The design verification tasks address the key problem of system interactions between structures and controls (fig. 15). Ground test facilities will be needed and need to be generic (not developed for a specialized space station). Existing facilities and ground test beds can be utilized but may require upgrading. Dedicated orbital tests are required to support concept verification, and orbiter opportunity tests should be conducted to take advantage of the Shuttle's low cost flight verification.

o GROUND TEST FACILITIES- GENERIC	RESEARCH ORIENTED, PROOF OF THEORY (SCIENTIFIC METHOD)
o GROUND TEST BEDS	PROJECT ORIENTED, SIMULATION, HARDWARE TEST, SYSTEM VERIFICA- TION
o DEDICATED ORBITAL TESTS	VERIFICATION OF CONCEPTS, STRUC- TURAL TESTING, 0-G TESTING, FREE FLYERS
o ORBITER OPPORTUNITY TESTS	LOW-COST TECHNOLOGY VERIFICATION

Figure 15

PROPOSED SPACE STATION TECHNOLOGY DEVELOPMENT GROUND RULE

With all the concern over funding, the panel developed a ground rule for space station technology development (fig. 16). First, a critical funding level should be established for each prioritized technology development task. Second, if the task cannot be funded to its critical research level, it should not be initiated.

- 0 ESTABLISH A CRITICAL FUNDING LEVEL REQUIRED FOR EACH PRIORITIZED TECHNOLOGY DEVELOPMENT TASK

- 0 IF YOU CANNOT FUND A TASK TO ITS CRITICAL RESOURCE LEVEL -----
DO NOT DO IT !!!

Figure 16

KEY ISSUES

The panel compiled a list of the key issues in guidance, navigation, and control as shown in figure 17. The design verification process involves simulation and the ground test beds to support the simulation. If the design verification process is started early, it could support the system synthesis, systems requirement, and the trade-offs that are necessary in deriving those system requirements. The process also requires ground tests, flight experiments using the Shuttle when the opportunity is available, and orbital flight tests (starting with the initial space station capability). Evolutionary growth is a big issue, from a standpoint of both technology improvements and mission expansion, and must be considered early. The structures and controls interaction is probably the driving issue. As spacecraft evolve, and the space station will evolve, the structure will become more flexible, and this cannot be modeled with the current capability. The attitude, control, and stabilization activity and the structures activity will become more closely entwined. It was suggested that the attitude, control, and stabilization tasks and personnel be separated from the guidance and navigation team and be placed with the structures activity. Although it is not a popular opinion, it needs to be studied so that both activities can use the same tools and recognize the interactions. There is a need for an early integration process before the space station requirements are established in order to recognize and ensure that the subsystem interactions are determined early. Thus, the best compromise can be made early in the design to facilitate the evolutionary growth of the space station. The philosophy relative to fault tolerance and autonomy must be established initially to tolerate the evolutionary growth for a system that is going to exist for 20 plus years.

- DESIGN VERIFICATION PROCESS

- SIMULATION
- GROUND TEST
- FLIGHT EXPERIMENT
- FLIGHT TEST

- EVOLUTIONARY GROWTH

- TECHNOLOGY IMPROVEMENTS
- MISSION EXPANSION

- STRUCTURES/CONTROLS INTERACTION

- EARLY INTEGRATION PROCESS

- FAULT TOLERANT/AUTONOMY

Figure 17

PROPOSED NASA-INDUSTRY COORDINATED PLANNING

The panel proposed several activities designed to enhance coordinated NASA-industry planning on the space station (fig. 18). A NASA space station summary report, published every 6 months and including results and/or progress reports on in-house and contract system studies, would keep industry abreast of the current status of space station activity. Currently, the Department of Defense (DOD) visits various industry plants to participate in the Independent Research and Development (IRAD) review cycle. NASA participation in the IRAD review cycle would generate industry visibility for NASA, as well as NASA visibility for industry, with the result that NASA would have an increased impact on industry. Also, better communications between NASA and DOD would be established, which would allow some synergism in technology budgets. Finally, NASA-industry space station workshops such as the current one should be held periodically.

- NASA SPACE STATION SUMMARY REPORT
 - ≤ 50 PAGES
 - PUBLISH EVERY 6 MONTHS
 - INCLUDE RESULTS OF SYSTEM STUDIES, IN-HOUSE AND CONTRACTED RESEARCH
 - ESTABLISH FORMAT TO MAKE INPUTS EASY
 - INCLUDE REPORT REFERENCE LIST
- NASA PARTICIPATE IN DOD IRAD REVIEW
 - VISIBILITY TO INDUSTRY AND VICE VERSA
 - NASA IMPACT INDUSTRY AND VICE VERSA
 - COMMUNICATION WITH DOD
- NASA/INDUSTRY SPACE STATION WORKSHOP PERIODICALLY

Figure 18

HUMAN CAPABILITIES

William Augerson
Arthur D. Little
Cambridge, Massachusetts

Space Station Technology Workshop
Williamsburg, Virginia
March 28-31, 1983

MAN IS A CRITICAL DESIGN ELEMENT

If you are going to have a manned space station, man is a driver in the system design (fig. 1). It is doubtful that anyone will accept the Greek idea that man is a measure of all things, but hopefully all will accept the fact that the crew is a major system and hence a critical design element in the space station. Even without man on the space station, teleoperators and a man-machine interface would exist.

The objective of human capabilities technology is to maximize the human/system productivity to meet the customer's requirements.

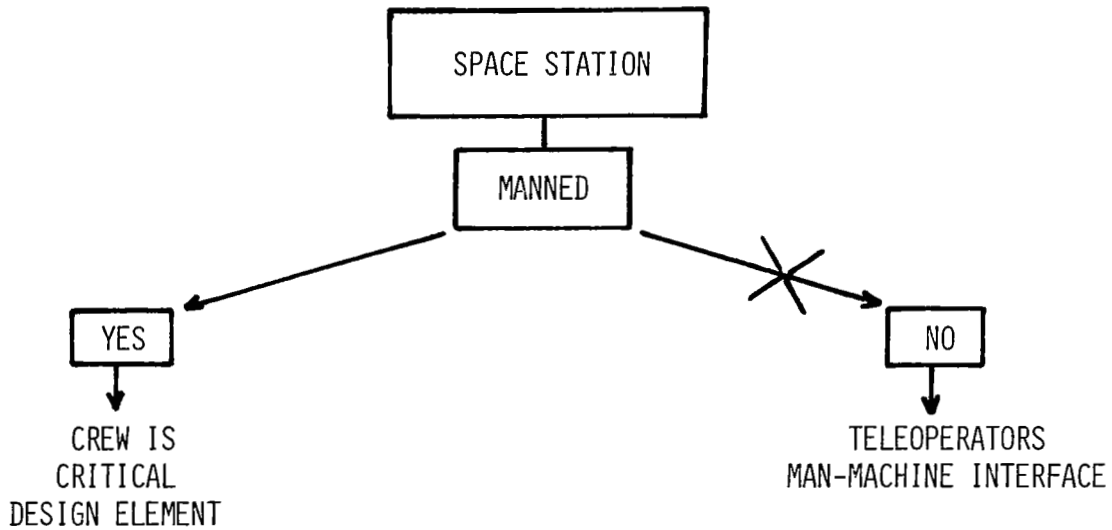

OBJECTIVE: MAXIMIZE HUMAN/SYSTEM
PRODUCTIVITY
(CUSTOMER REQUIREMENT)

Figure 1

BACKGROUND

People do not really appreciate the range of performance of the human visual analyzer (man) (fig. 2). Robotics technology is still far from capturing the flexibility and adaptability of the opposable thumb, the ear, the eye, or the human brain. As a matter of fact, humans are very strong. Omnivores are social creatures and work well in teams. They use language, use tools, and invert tasks. The species is a specialist in diversity.

Ten thousand years ago, homo sapiens was on all parts of the Earth, except Antarctica. He was living and working 3 miles high and had flourishing communities around the Arctic Ocean and in many desert areas. Later, he took to the sea, then the air, and now space. Homo sapiens is an explorer.

The recent history of putting man in complex systems, however, has tended to emphasize this human versatility and adaptability as a buffer to cope with some of the shortcoming of some engineering subsystems to fulfill all of their early design promises. Those trades were made because the community could not prove that man would fail. Indeed, the relatively recent history of Skylab showed once again how man could save the entire system, and how human adjustments made the difference in the scientific productivity of that operation. Some substantial rearranging of philosophy needs to be made. The bottom line is that the crew is ready and tested, but the factory and tools need more work.

- HUMAN OPERATING CHARACTERISTICS
- ANCIENT HISTORY
- RECENT HISTORY
- THE CREW IS READY AND TESTED. THE TOOLS AND FACTORY NEED SOME WORK.

Figure 2

CONSIDERATIONS

Several issues need to be addressed in considering the technology development in human capabilities for a space station (fig. 3). Given that the potential mission of a station is quite diverse, the issue of productivity becomes a star to steer by. It is important to consider not only human productivity but also the productivity of humans using devices. The duration of the work duty cycle in the station as well as the life of the station are both a problem and an opportunity. Certainly, the longer the duration, the less clamor there will be, and the greater the sensitivity to habitability problems. At the same time, there are some substantial environmental engineering and health issues that are imbedded in long duration. From the industrial world, there is considerable knowledge about threshold limit values for various chemicals. These values are generally developed for a 40-hour work week (8-hour day) for one chemical. When a 3-month stay (24-hour day) at a space station for a crew and a variety of chemicals in the environment is considered, the habitability problem becomes more complex. Diversity is also a key consideration. It is important to maximize the number of customers (users) and they will need to perform a variety of functions. Therefore, it is important not to foreclose options in human participation too rapidly. Likewise, with growth and flexibility, man's capability should not be traded off early.

- PRODUCTIVITY
- DURATION
- DIVERSITY - MISSION/FUNCTION WORK FORCE
- GROWTH AND FLEXIBILITY

Figure 3

CONCEPTUAL MODELS

To recapitulate some of the history of aeronautical development (fig. 4), test pilots are remarkable examples of homo sapiens at work. They are brilliant and occasionally lucky people who specialize in taking an unstable vehicle with a somewhat questionable control system and an absurd crew station layout and, most of the time, successfully overcoming those obstacles to run a successful flight test. On the other hand, no one would like their family flying in a commercial aircraft that accepted such a challenge for the pilot. It is about time to begin thinking in terms of crew-oriented design philosophy, quite parallel to the current development in the commercial and, for that matter, in the military aviation sector. Certainly, as in the commercial airline sector, it is important to remember that the passengers have an opinion about the design (habitability).

TEST PILOTS VS. AIRLINE PILOTS

CREW-CENTERED DESIGN

(REMEMBER THE PASSENGERS)

INDUSTRIAL MODEL

Figure 4

ANALOGS AND METAPHORES

Analogs were mentioned early in the panel session. The panel considered them to be very important and very numerous (fig. 5). At the same time, these experiences are not well compiled or easy to get to. It is important that NASA begin digging out these data. NASA is good at illuminating social and environmental issues that exist. A classic example is the location of comfort facilities immediately adjacent to dining facilities in Antarctic station and military field installations and, unless changes are made, in future space stations.

- VERY IMPORTANT
- VERY NUMEROUS
- NOT COMPILED
- ILLUMINATE SOCIAL/ENVIRONMENTAL/OPERATION ISSUES
- "COMPANY TOWN WITH AN INTERNATIONAL AIRPORT IN ORBIT"

Figure 5

WORKING GROUP TEAMS

The human capabilities panel was divided into three working group teams, as shown in figure 6. The medical, physiology, psychology, and human factors experts were grouped into habitability. In work performance, the classic interest groups in human performance were merged with people in teleoperators and robotics, IVA and EVA (often falsely portrayed as competitors). And the man-machine interface team was a fairly traditional one.

- HABITABILITY
- WORK PERFORMANCE (IVA/EVA/TELEOPERATORS)
- MAN-MACHINE INTERFACE

Figure 6

TECHNOLOGY STATUS

The panel assessed the technology status of habitability technology, as shown in figure 7. A comprehensive and integrated approach perhaps has not been accomplished because all the answers about how to do it are not known. This suggests that operating in space does pose some challenges to the people who have to live and work on the space station.

AN INTEGRATED AND COMPREHENSIVE
APPROACH TO HABITABILITY
HAS YET TO BE DONE

Figure 7

STATE OF THE ART

Habitability state of the art (fig. 8) relative to the space station can be linked to two long-duration spacecraft, Skylab and Salyut. Analogous habitability situations include long-duration nuclear submarine missions, Antarctic missions, and passenger aircraft.

- SPACECRAFT
 - SKYLAB
 - SALYUT?
- ANALOGS
 - NUCLEAR SUBMARINES
 - ANARCTIC MISSIONS
 - PASSENGER AIRCRAFT DESIGN

Figure 8

HABITABILITY SYNTHESIS

Most people feel that sociology and behavioral studies are very soft. This is a topic that may need to be revisited sometime in the future. In terms of failure and risk analysis, a look at the history of expeditions and complex military activities shows that many teams or groups operating in very severe environments come apart socially and organizationally before the environment gets to them. This can also happen in other environments. A creative definition for synthesis (fig. 9) is to engineer the environment and operations to optimize sustained human performance. This is not an answer but it defines an approach and a way to think about habitability that is not sentimental.

Bad food on an oil platform is not cost effective. The good energy exploration managers do not hire first-class cooks to serve lobster because of any sentimental attachment to the work force. It is the price of doing business and maintaining a high level of performance. Making too many trades and accommodations in that area, such as hiring a low-budget cook, does not pay off. Payoff is the key to customer acceptability and is measured by productivity. The foundation of productivity is habitability.

DEFINITION:

ENGINEERING THE ENVIRONMENT AND OPERATIONS TO OPTIMIZE
SUSTAINED HUMAN PRODUCTIVITY

SIGNIFICANCE:

- HABITABILITY IS THE FOUNDATION OF SPACE STATION PRODUCTIVITY
 - PRODUCTIVITY IS THE ULTIMATE CUSTOMER PAYOFF
 - PAYOFF IS THE KEY TO CUSTOMER ACCEPTABILITY
- 

Figure 9

MODEL PROCESS

Instead of just listing the habitability technology issues, a model process was established (fig. 10) in the event that a process problem was imbedded in some of the difficulties that existed. This model process goes beyond the usual "Give them a handbook and maybe they will read it" concept. Handbooks are almost instantly out of date in this area. It would be to NASA's advantage to establish a process whereby habitability technology issues are detected fairly early from the various sources. There should be a living handbook embedded in the process so that the effort goes somewhere.

PROCESS

- INPUTS: EMERGING HABITABILITY ISSUES
IN PROPOSED ARCHITECTURES
- SPECIFICATIONS: DEVELOPMENT OF HABITABILITY
REQUIREMENTS
- ACTIONS: IMPLEMENTATION STRATEGIES

SOURCES

FLIGHT OPERATIONS
FLIGHT EXPERIMENTS
CREW INPUTS
PAST EXPERIENCE
ANALOGS
GROUND SIMULATIONS
PANELS/CONSULTANTS

Figure 10

FUNCTIONAL APPROACH

There is no point in establishing a process if it is not hooked up to anything. In this case, it is the continuing process, as shown in the functional approach diagram (fig. 11). It would be useful, administratively or organizationally, to have a 450-pound gorilla as the human capabilities manager to see that the process does not stop and that the crew has someone as advocate when the trading time comes.

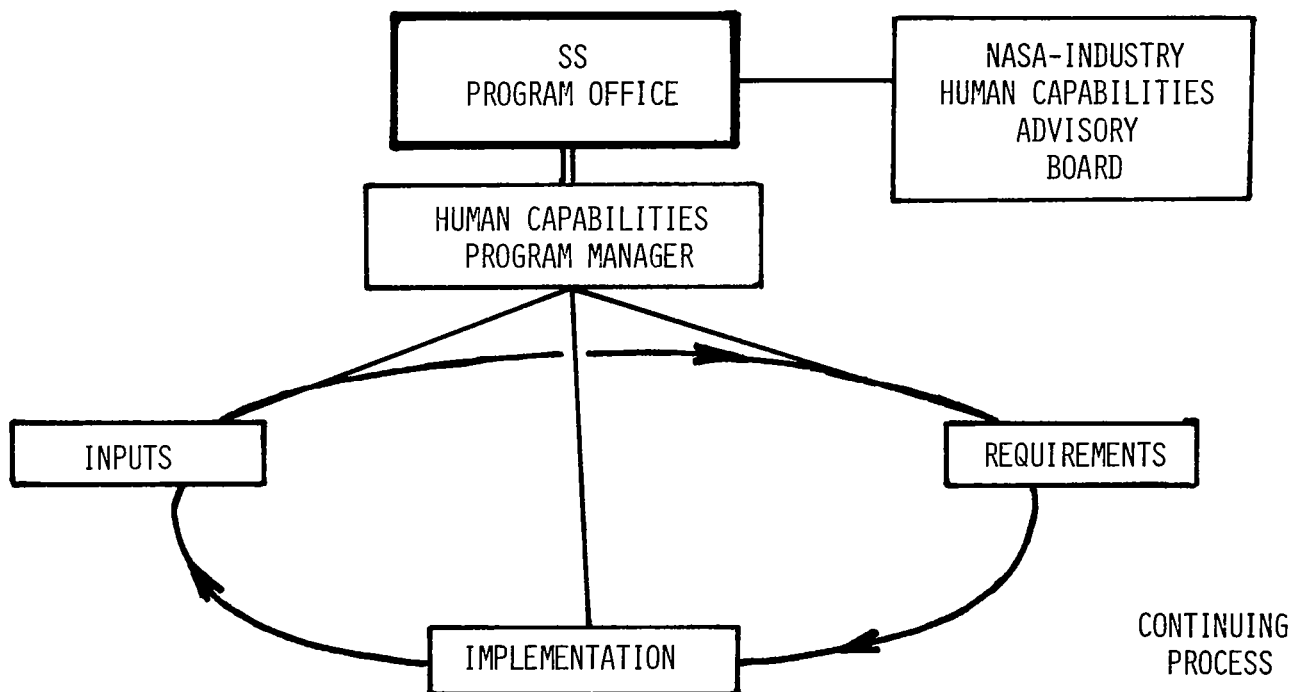

Figure 11

HABITABILITY CATEGORIES

The habitability categories set forth by the initial NASA working group are shown in figure 12 and are currently conceptually structured. The panel concluded that these categories were necessary but a long way from sufficient. As a matter of fact, any one of those topic headings is a major subcontinent for exploration in its own right. The categories set forth by the present workshop are listed to point out the enormity of synthesis that is going to be required, both of the rest of the program and of the community. Some of the issues driven by duration have been discussed. Consider acoustics for a moment. Acoustics is a health problem, among other things. For a high level of noise in an industrial operation, a handbook will provide the maximum exposure allowed by the Occupational Safety and Health Administration. However, the handbook does not say anything about the health consequence of a steady week or a year at that level. There is insufficient time and money to fill in those data points. On the other hand, acoustics (at a high noise level) is a sleep and operational effectiveness issue as well as a communication issue. It is an operational issue in terms not only of productivity but also of glitches in the operation (example: someone thought you said "no" and you said "go"). Acoustics is a social issue too. If you have to yell at someone every time you want something, it gets annoying after a while. There are serious and difficult implications in setting acoustic standards for environmental control system design, suit design, communications, crew station, power, and structure. NASA will have to develop a process for making some of these trades in a way that increases, instead of decreases, productivity.

INITIAL NASA WORKING GROUP

FOOD SYSTEM TECHNOLOGY
DECONTAMINATION TECHNOLOGY
MEDICAL CARE
VIBROACOUSTIC ENVIRONMENT CONTROL
HUMAN PERFORMANCE ASSESSMENT (HISTORICAL)

PRESENT WORKSHOP

INTERIOR DESIGN/LAYOUT
DEBRIS/CONTAMINATION/WASTE CONTROL/MANAGEMENT
MEDICAL/EMERGENCY CARE - SAFE HAVENS
ENVIRONMENTAL - ACOUSTIC, LIGHTING, ETC.
-- (INCLUDED IN PROCESS)
PREVENTIVE/MEDICAL COUNTERMEASURES
WORK/REST CYCLES - RECREATION/CREW ROTATION
MAINTENANCE/TRAINING
COMMAND/CONTROL/ROLE RELATION/GOVERNMENT
SOCIAL STRUCTURE/COMMUNITY HIERARCHY
HOUSEKEEPING
COMMUNICATIONS
STORAGE/INVENTORY
PERSONAL HYGIENE
AUTONOMY
EVA/IVA
RESTRAINTS/MOBILITY

Figure 12

ISSUES

The panel's prescription was to conduct a comprehensive assessment of habitability technology and the many issues imbedded in it (fig. 13). The assessment of these topics suggests the magnitude of that agenda and it has been recommended that it be approached organizationally. However, the problem is large enough to have an administrative focus so that it does not get diffused and lost.

- CONDUCT COMPREHENSIVE ASSESSMENT OF HABITABILITY
- CONSOLIDATE RESPONSIBILITY FOR HUMAN CAPABILITIES
WITHIN PROGRAM OFFICE.

Figure 13

MAN-MACHINE INTERFACE: SPACE STATE OF THE ART

Man-machine interface technology is less controversial than the habitability technology. A listing of state-of-the-art space technology man-machine interface items that are applicable to the space station are given in figure 14. Many of these concepts will make a significant contribution if they can be developed and embodied in the space station.

- LARGE ARRAYS OF SINGLE-PURPOSE DISPLAYS (CLUTTERED WORK STATION)
- APPLICATION OF MONOCHROME CRTS (COLOR CRTS NOT SPACE RATED)
- SOME MULTIMODE DISPLAYS, BUT ONLY PARTIAL INTEGRATION OF INFORMATION
- LARGE ARRAYS OF SINGLE-PURPOSE CONTROLS (CLUTTER WORK STATION)
- LIMITED PHYSICAL AND FUNCTIONAL SYSTEMS INTEGRATION
- EXTREMELY LIMITED REVERSIONARY CAPABILITY

Figure 14

MAN-MACHINE INTERFACE: AERONAUTICAL STATE-OF-THE-ART

Playing to the theme of building on the work of the commercial and military sectors, a very impressive list of aeronautical technology items related to the man-machine interface is presented in figure 15. Many of these items are already developed but are not space qualified. Some powerful technologies (i.e., head-up displays (HUD's), helmet-mounted displays) are emerging and being put to use.

- PILOT ROLE SHIFTING FROM CONTROLLER TO MANAGER/SUPERVISOR
- APPLICATION OF HIGH-RESOLUTION COLOR CRT TECHNOLOGY
- SOME INFORMATION INTEGRATION THROUGH PICTORIAL, MULTIMODE DISPLAYS
- CRT REVERSIONARY CAPABILITY
- EXTENSIVE USE OF DISTRIBUTED MICROPROCESSORS FOR PHYSICAL/FUNCTIONAL INTEGRATION
- BACKUP ELECTROMECHANICAL INDICATORS
- INTEGRATED CAUTION AND WARNING SYSTEMS
- CONTINUED USE OF DEDICATED CONTROLS (SOME CREW STATION CLUTTER)
- EMERGING HUD TECHNOLOGY
 - EMERSED - OPTICS - HUD
 - HOLOGRAPHIC OPTICS HUD

Figure 15

BENEFITS OF GENERIC WORK STATION

Although the latest Boeing aircraft does have a little less exciting reentry problem than the Shuttle, it is a crew station that has been designed for simplicity and to support the crew. Such is not the case for the space station. The idea of a generic or generalized work station, particularly when coupled with an all-class station (an interactive display), would provide many benefits to the space station, as shown in figure 16. The generic work station could also be readily moved around as needed at different parts of the space station and would be adaptable to both scientific and commercial payloads.

- REDUCED COST IN DESIGN AND PRODUCTION
- MINIMIZES RETRAINING/CROSSTRAINING
- ENHANCES SAFETY THROUGH REDUNDANCY/BACK-UP

Figure 16

ENABLING TECHNOLOGY DEVELOPMENT NEEDS

Enabling technology development needs for a space-rated generic workshop are listed in figure 17.

- LARGE SCREEN DISPLAYS
- MULTI-FUNCTION CONTROLS
- DISTRIBUTED PROCESSING/BUSSING FOR MULTI-LOCATION OPERATION
- DEFINE AND IMPLEMENT AN ALL-GLASS INTEGRATED MULTIMODE TESTBED
- GUIDELINES AND STANDARDS FOR DESIGN
- CREW HELMET WITH HUD
- MODELING OF MAN AS ELEMENT IN AN INFORMATION-PROCESSING NETWORK
- WORK TOWARD APPROPRIATE "NATURAL LANGUAGE" FOR MAN-MACHINE INTERFACE
- AUTOMATIC ACQUISITION OF DATA BASE FOR KNOWLEDGE-BASED SYSTEMS

Figure 17

MAN-MACHINE INTERFACE ISSUES

Key issues for the development of man-machine interface technology are given in figure 18.

- CUSTOMER (INDUSTRY) REQUIREMENT FOR USER FRIENDLY INTERFACE, E.G.,
 - STATE-OF-THE-ART DISPLAY/CONTROL/MAN-MACHINE INTERFACE
 - EFFICIENT EXPERIMENT INTEGRATION METHODOLOGIES
- PROJECTED TECHNOLOGY DEVELOPMENT FUNDING GROSSLY UNDERSTATED
- ESTABLISHMENT/ENFORCEMENT OF NASA-WIDE CREW STATION INTERFACE DESIGN SPECIFICATIONS
- ESTABLISHMENT OF AN INTEGRATED MULTIMODE TEST BED

Figure 18

EMERGING TECHNOLOGIES

The emerging technologies related to work performance are listed in figure 19. These technologies are traditionally considered as competitors or radical alternatives. Instead, it is in NASA's interest to think of these more nearly as different arrangements of capital and labor to produce production. To use teleoperators, more needs to be known about how the human operator performs than is presently known. From a superficial reading of the robotics literature, other kinds of performance must be studied before the program for the robot can be written.

- TECHNIQUES FOR ACCURATELY MEASURING HUMAN WORKLOAD
- TELEOPERATORS
- ADVANCED COMPUTER GRAPHICS SYSTEMS
- ARTIFICIAL INTELLIGENCE

Figure 19

ENABLING TECHNOLOGY REQUIREMENTS

The requirements for work performance enabling technology are listed in figure 20.

- SPACE HUMAN ENGINEERING STANDARD
 - ESTABLISHED DESIGN TO ASSURE FUNCTIONAL WORK SPACE DESIGN
- SPACE HUMAN PERFORMANCE HANDBOOK
 - QUANTITATIVE DATA BASE ON HUMAN PERFORMANCE ON IVA, EVA, AND TELEOPERATION TASKS. VALIDATED IN SIMULATION AND FLIGHT
- SPACE HUMAN FACTORS MAN-MACHINE INTEGRATION SPECIFICATION
 - CREW WORK SPACE DESIGN DETAILS TO ENABLE CREW PERFORMANCE AT OR EXCEEDING THE LEVELS REFERENCED IN THE PERFORMANCE HANDBOOK.

Figure 20

KEY ISSUES

Work performance key issues are given in figure 21. Relative to the inadequate data base of human performance at zero gravity, this is not due to a lack of zero-gravity environment activity. Instead, the other mission requirements have been structured such that space data which are sufficiently substantial (good confidence in the range of variables) and useful in the design sense are not available. Such data could be obtained during certain Shuttle operations. Also, increased attention and investment must be made in simulation facilities.

- THERE IS AN INADEQUATE DATA BASE OF HUMAN PERFORMANCE IN THE ZERO-G ENVIRONMENT
- THERE IS NO AGREED UPON HUMAN ENGINEERING METHODOLOGY TO INTEGRATE MAN INTO SPACE SYSTEMS
- THE RELATIVE ROLES OF MAN, TELEOPERATORS AND AUTOMATION HAVE NOT BEEN ESTABLISHED
- PLANNED SIMULATION FACILITIES AND TECHNIQUES ARE INADEQUATE FOR SPACE STATION DEVELOPMENT

Figure 21

SUMMARY

In conclusion, habitability is more than just life support and there is a substantial technology/application void (fig. 22). Habitability needs both visibility and responsibility in the space station program to ensure the optimum use of man in space. In the area of work technology, IVA and EVA teleoperators and robotics should be considered as tools and not competitors. A generic work station can be a contemporary of the early space stations. Flexibility of a future space station requires this.

HABITABILITY

- IS A LOT MORE THAN LIFE SUPPORT
- IF YOU WANT USEFUL WORK, PAY ATTENTION
- THERE IS A SUBSTANTIAL TECHNOLOGY/APPLICATION VOID
- NEEDS VISIBILITY, RESPONSIBILTY IN SPACE STATION PROGRAMS

WORK TECHNOLOGY

- IVA/EVA/TELEOPERATORS/ROBOTICS ARE TOOLS, NOT COMPETITORS.

MAN-MACHINE INTERFACE

- GENERIC WORKSTATION CAN BE CONTEMPORARY OF EARLY STATION -- FUTURE FLEXIBILITY REQUIRES IT.

Figure 22

AUXILIARY PROPULSION

Sanders D. Rosenberg
Aerojet Tech Systems Company
Sacramento, California

Space Station Technology Workshop
Williamsburg, Virginia
March 28-31, 1983

INTRODUCTION

When man is put in the loop, almost anything can happen. Caution must be exercised in permitting life cycle costs analysis to control technology investment. It has been said that one of the ways of reducing cost is to stay with the old tried and true technology. However, when requirements of a permanent space station are considered (15-year life, the issues associated with health monitoring, maintenance, and repair), the conclusion is that very little, if anything, is really state of the art. Before investing in old technologies to make them comply with the requirements of a permanent space station, the question of whether or not it is worth putting the money there as opposed to advancing the state of the art should be considered. Program managers and system designers must not make the mistake of selecting old technologies in the belief that they are state of the art.

MAN, A PERMANENT RESIDENT?

The issue of whether or not the early space station will have man as a permanent occupant has yet to be decided. However, man must be baselined as part of the design from the very beginning. The progression is an issue for the manager to decide eventually, but the engineer-scientist can go forward even without that decision, if it is accepted from the beginning that man must be baselined into the design.

GAPS IN THE DISCIPLINE

As each narrow discipline is addressed, it is apparent that there are gaps between disciplines and among several disciplines. One of the working groups must be given a preeminent role (possibly systems-operations technologist), but it must be infused with specialists from all of the other required working groups. All of the choices cannot be left to the system designer; he needs a little help along the way.

EXAMPLES OF CLOSING THE GAP

Consider the following example of a propulsion system designer confronted with the problem of taking liquid cryogenics at low pressure and transforming them to gases at high pressure and somewhat higher temperature to run certain devices. If the propulsion system designer is burdened with the task to the exclusion of all of the other potential systems on board, the propulsion system is going to become very cumbersome. There may be an opportunity for the thermal designer and propulsion systems designer to work together, utilizing waste heat to gasify liquid propellants.

Another example of exploiting the opportunity for cross discipline interplay is in the area of regenerative power. Fuel cells consume oxygen and hydrogen gases to manufacture power on the dark cycle, and then use solar power on the light cycle to electrolyze water to provide gaseous hydrogen and oxygen. Thus, gaseous hydrogen and oxygen are provided in precisely the form that the propulsion designer requires. These issues have to be addressed from an overall systems level.

AUXILIARY PROPULSION RATIONALE

Accepting the fact that man is on board the space station, oxygen must be on board. For the moment and for the foreseeable future, that is an immutable fact of nature. The question for the propulsion systems designer then becomes "What's best to do with the oxygen?" The answer is to use hydrogen as the fuel to produce an oxygen-hydrogen bipropellant combination. This is best for propulsion from a performance point of view and is also best from a life cycle cost analysis viewpoint. It also ties into other systems, such as power generation, life support, and toxicity. These are comparatively benign propellants and they generate a chemically benign exhaust, on a relative basis.

In addition, if the permanent space station is considered as a transportation node at some point of time, oxygen-hydrogen propulsion for orbit transfer vehicles and similar vehicles is the enabling technology for many long-term trans-LEO requirements. In looking to the future in an evolutionary sense, it again becomes the propellant combination of choice. In talking about 30-lbf thrust class GO_2/GH_2 thrusters for orbit maintenance and 0.1-lbf thrust class resistojets for drag makeup, the panel endorsed the NASA plans and recommendations.

CONCLUSION

In the auxiliary propulsion area, the panel believes that we know what we have to do, how we have to do it, and what it will cost. Permanent space station propulsion is ready to go.

FLUID MANAGEMENT

Dale Fester
Martin Marietta Company
Denver, Colorado

Space Station Technology Workshop
Williamsburg, Virginia
March 28-31, 1983

INTRODUCTION

The Fluid Management Panel's assessment of the technology is summarized in figures 1 to 4. Since a baseline space station was not defined as a reference guide and the results of the eight contracted space station studies were not available as input, the assessment focused on technology and not programatics. The ground rules that were key to the deliberations and guided the assessment are:

- (1) The space station will be operational in 1991
- (2) A space-based OTV will be operational in 1992

Thus, the capability to transport, transfer, and resupply all fluids, including those for the OTV, is required in the initial space station. The only evolutionary aspect is the refinement of capability.

Fluid management is a key item required for the space station. It includes both servicing the space station and providing space station services, and covers the operations listed in figure 1. Fluid transfer to orbit can be accomplished by modular replacement of tanks, by using dedicated tankers, by scavenging fluids from the orbiter and the external tank, or by any combination. Liquid storage and supply entails low-g acquisition and expulsion of the fluids. Fluid transfer and resupply includes all lines and components, refill of both space station supply tanks and user tanks (for example, the OTV), and the necessary controls. Integral thermal control systems are also included and cover such items as insulation, coatings, open- and closed-loop refrigeration, and radiators.

- 0 FLUID MANAGEMENT INCLUDES
 - FLUID TRANSPORT TO ORBIT
 - LIQUID STORAGE/SUPPLY
 - FLUID TRANSFER/RESUPPLY
 - INTEGRAL THERMAL CONTROL

- 0 A KEY ITEM TO SPACE STATION

Figure 1

TECHNOLOGY REQUIREMENTS

The Fluid Management Working Group of the Space Station Technology Steering Committee (SSTSC) identified the technology requirements and defined the current state of the art for the existing plan. The seven original tasks, as well as changes and additions, are shown in figure 2. No priorities were established for the technology requirements because all items are considered mandatory. Item 5 (reuseable Earth-to-orbit cryogen transport) was deemed enabling rather than a performance improvement item since the cryogen storage tanks must be filled prior to OTV flight. Item 9 (manned versus autonomous operations) was changed to enabling for the same reason. It is noted that "long-term" may not be the same for the initial station and the evolved station.

Three delta (add-on) items were defined. Fluid motion assessment must be added to the fluid resupply plans. Guidance and control requires decoupling and stabilization of the forces imposed on the space station by liquid moving within the liquid tanks. This is needed for either storage at the station or remote storage. Methods for controlling fluid motion and the complexities resulting from these methods should be studied in the Cryogenic Fluid Management Facility (CFMF) using reference fluids in transparent tanks in Shuttle mid-deck experiments, and also in tethers or free-floaters out of the payload bay. No new task description is written for this effort, since it should be included within the existing plan.

Although fluid leak detection was identified in the NASA plan, no specific approach was outlined. The Air Force Rocket Propulsion Laboratory is sponsoring an on-going program using ultrasonics for leak detection of storable fluids. This system should be investigated for application to cryogenics. Fluids for this work may already be covered within the original plan.

The final delta item (item 7) pertains to long-term orbital cryogen storage. This item concerns system degradation with time and efficient tolerance. The attack of organic material by the atomic oxygen present in low-Earth orbit is a current problem which leads to concern about effluent tolerance. Must the entire fluid be unvented? If so, a closed-loop system would be needed and reliquification could be required. This item would require additional funding.

Three new tasks were added to the working group plan. A control, instrumentation, and diagnostics function is needed from the standpoints of safety, contamination, and performance. This task is needed for fluid system operation. It is doubtful that EVA activity would be required for routine servicing; rather, these activities should more appropriately be accomplished remotely. A manned versus autonomous operations study is needed, again to focus on safety, contamination, and performance issues. Finally, a fluid systems study is needed to define the space station fluid requirements and establish pertinent ground rules which will be used to guide the other fluid system technology programs.

The panel also considered requirements for flight tests to develop space station technology and to identify desired versus mandatory flight tests as a prerequisite to the first space station flight. This evolution led to the identification of mandatory flight tests for cryogenic and noncryogenic fluid resupply and for long-term orbital cryogen storage, as noted in figure 2.

			DELTA
F	1) CRYOGENIC FLUID RESUPPLY	} ENABLING	FLUID MOTION
	2) NON-CRYOGENIC FLUID RESUPPLY		
	3) ZERO-LEAKAGE FLUID COUPLINGS	} SAFETY } CONTAMINATION	ULTRASONIC
	4) FLUID LEAK DETECTION INSTRUMENTATION		
	5) REUSABLE EARTH TO ORBIT CRYOGEN TRANSPORT	} PERFORMANCE } IMPROVEMENT	
	6) FLUID QUANTITY GAUGING INSTRUMENTATION		
F	7) LONG TERM ORBITAL CRYOGEN STORAGE	ENABLING	DEGRADATION/ EFFLUENT TOLERANCE
NEW	8) CONTROL, INSTRUMENTATION & DIAGNOSTICS	} SAFETY } CONTAMINATION } PERFORMANCE	
	9) OPERATIONS (MANNED VS. AUTONOMOUS)		
	10) FLUID SYSTEMS STUDY		

F = MANDATORY FLIGHT TESTS

Figure 2

SPECIAL FLUIDS AND FLUID QUALITY

Instead of identifying specific tasks, the panel noted two special items that should be addressed (fig. 3). The first concerns the resupply of special fluids like liquid helium, which is used for sensor cooling. It has not been determined if provisions for these special fluids should be included on the space station or if the system should be returned to the ground for resupplying. The special fluids are candidates for modular replacement of tasks. The second item concerns fluid quality and possible contaminant buildup due to trace quantities of impurities in the fluids. For example, trace quantities of water and nitrogen exist in hydrogen. At liquid hydrogen temperature, these frozen contaminants could build up in a continuous use-resupply system and present potential clogging problems. A similar situation could arise with oxygen. It is recommended that the Space Station Task Force consider these items.

RESUPPLY OF SPECIAL FLUIDS, E.G., LIQUID HELIUM
GROUND VS. SPACE STATION

FLUID QUALITY/CONTAMINANT BUILDUP
PROPELLANT PURITY

Figure 3

CRYOGENIC FLUID MANAGEMENT FACILITY (CFMF)

The Fluid Management Panel considers the Cryogenic Fluid Management Facility (CFMF) to be absolutely essential to obtain the technology needed for handling cryogenic fluids in space (fig. 4). The current plan calls for flying the first of three missions in late 1987, which will provide enabling technology for the space station. This technology is also needed for cryogenic space-based OTV's, cryogenic orbital maneuvering vehicles (OMV's) having loiter capability, and space-based laser systems.

Adequate funding is imperative. Many schedule slips have occurred since the beginning of the program in 1978. It would be very desirable to have much of the cryogenic fluid handling information at this time. It is important that there not be more postponements in the program. It must also be recognized that the needed data cannot be obtained in 1 year.

Early ground testing of parts of the facility need to be conducted to uncover any latent problems that might exist. Development items should be added prior to test article qualification testing, since the assumption that no problems will be encountered is unrealistic.

A more ambitious flight program, with emphasis on added technology investigation and additional missions, is needed to make sure that all the desired information is obtained. With added emphasis, the CFMF could fly in early 1987, a schedule shortening of 6 months. However, the real payoff in increased emphasis is having greater confidence in obtaining an increased quantity of meaningful information.

It is recommended that fluids and cryogenic transfer experimentation be accelerated.

- ENABLING TECHNOLOGY FOR SPACE STATION
- ADEQUATE FUNDING IMPERATIVE
NO MORE POSTPONEMENTS
CAN'T GET INFORMATION IN ONE YEAR
- CONSIDER INCREASED EMPHASIS
EARLY GROUND TESTING
MORE AMBITIOUS FLIGHT PROGRAM
TECHNOLOGY INVESTIGATIONS
ADDITIONAL MISSIONS
COULD FLY EARLY 1987

Figure 4

COMMUNICATIONS

G. J. Bonelle
TRW Electronic Systems Group
Redondo Beach, California

Space Station Technology Workshop
Williamsburg, Virginia
March 28-31, 1983

INTRODUCTION

Communications in any system is one of the last technologies to be considered, and sometimes it is considered too late to impact the system (fig. 1). This was somewhat the impression on reviewing the NASA budget for two mission scenarios for the space station. However, that budget fortunately was well spent, and the money was spent to get the most benefit per dollar.

Another thing that is very often forgotten is that technology cannot be produced in a vacuum. In fact, in conducting independent research and development (IR&D), the first phase is to define the requirements which must be time phased, because very often the conditions will change during the life of the system. From the requirements, a set of architectures that are at least representative of that era are produced. If the exact requirements have not been established, at least boundaries can be set on the requirements for that architecture. When this is completed, then the technology that is really needed can be defined. The major criticism of the work that was presented to the panel is the lack of a firm set of requirements.

- O COMMUNICATIONS ALWAYS LAST TO BE CONSIDERED

- O A SET OF TIME-PHASED COMMUNICATIONS ARCHITECTURES IS AN ESSENTIAL PRECURSOR TO EFFICIENT COMMUNICATIONS TECHNOLOGY DEVELOPMENT

- O TIME-PHASED REQUIREMENTS DEFINITION IS ESSENTIAL TO THE ARCHITECTURE

Figure 1

COMMUNICATION ARCHITECTURE

An overall communication architecture is required, particularly because the communications system for the space station is not just a system. It is a collection of subsystems, as shown in figure 2, and it is a tremendous task to tie them all together. For example, some of the links expected in the space station are internal communications, EVA, flight preflyers, orbital-transfer vehicle, and the Shuttle. The panel took each link independently and developed the requirements, limitations, and technology options.

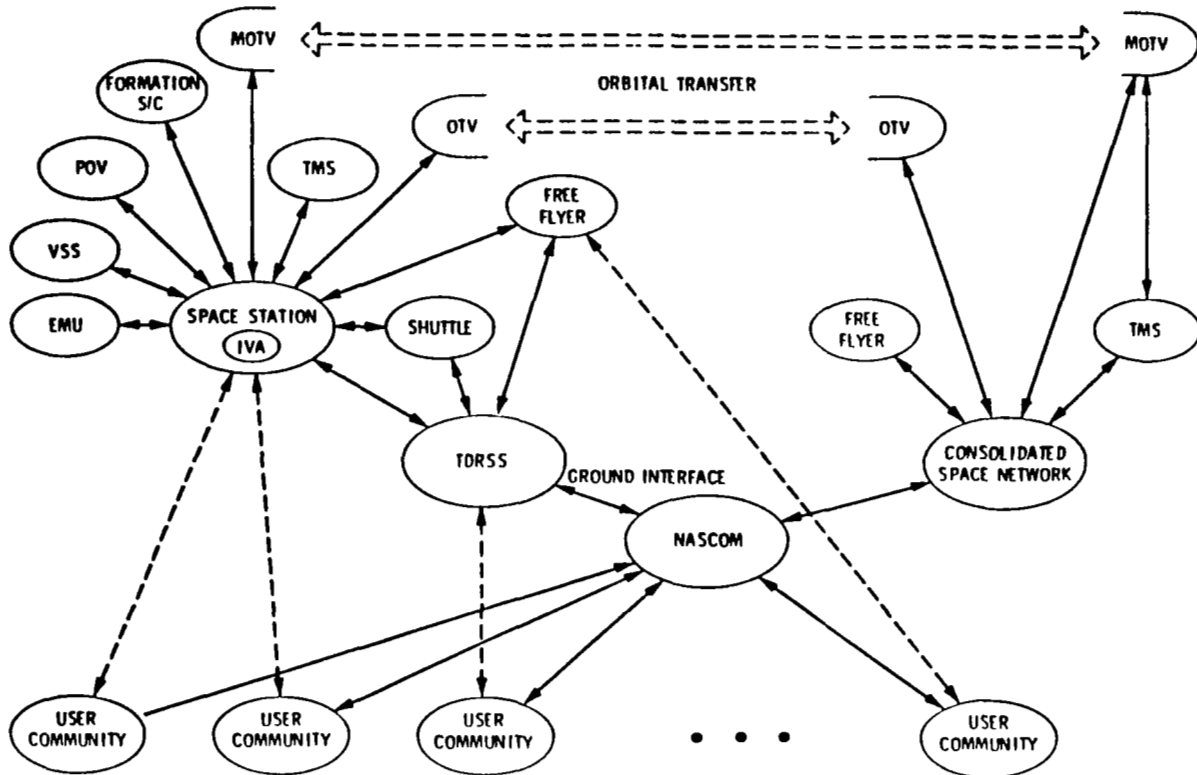

EMU	extravehicular maneuvering unit	NASCOM	NASA communications system
GPS	global positioning system	OMV	orbital maneuvering vehicle
IVA	intravehicular activity	S/C	spacecraft
LECPV	low-energy close-proximity vehicle	TDRSS	tracking and data relay satellite system
MOTV	manned orbital transfer vehicle	TMS	teleoperator maneuvering system

Figure 2

INTRAVEHICULAR COMMUNICATIONS

The subject of intravehicular communications raises very interesting and unusual requirements for communications (fig. 3). Normally, a telephone could be used inside a vehicle or wires could be attached to the man when he is in his pressure suit. The main ambition of communications on the space station is for the 10- to 12-man crew to be able to move around in the closed container without constraints.

Among the limitations of wireless communications are the bulk and excess power requirements of RF systems. Even fiber optic cables and intermodule connections are complex. Television equipment requires automations features which are not yet available.

The technology options include short-range laser links in lieu of fiber optics for module to module communications and antennas to the outside. IR broadcasting has been used in airplane cabins and theaters as an augmentation for the deaf. Also needed are higher resolution, high sensitivity, solid-state transformers and television equipment.

REQUIREMENTS

- WIRELESS CREW VOICE AND DATA COMMUNICATIONS FOR 10-12 CREWMEN
- TRANSFER OF COMMUNICATION SIGNALS TO/FROM ANTENNAS (VERY WIDEBAND SIGNALS)
- EXTENSIVE CLOSED-CIRCUIT TV, TELEPRESENCE SUPPORT

CURRENT LIMITATIONS

- WIRELESS (R.F. - RADIO FREQUENCIES)
 - BULKY, EXCESS POWER (MANY BATTERIES)
- HARDLINE
 - COMPLEXITY OF CABLE AND FIBER OPTICS INTERMODULE CONNECTIONS
 - GROWTH (BUILD UP CHANGES ARE A CONCERN)
- TV EQUIPMENT
 - LACK OF PROVEN AUTOMATED FEATURES
 - LIMITED QUALITY OF STEREO TV
 - PERFORMANCE LIMITATIONS OF LOW-COST SOLID-STATE DEVICES

TECHNOLOGY OPTIONS (TO OVERCOME LIMITATIONS)

- SHORT-RANGE LASER LINKS (MODULE TO MODULE, ANTENNA TO MODULE INTERFACE)
- IR BAND EXPLOITATION
- HIGH RESOLUTION, HIGH SENSITIVITY, AND SOLID-STATE TV COMPONENTS
- TV EQUIPMENT AUTOMATION, INCREASED INTELLIGENCE

COMMENT

- IR FLOODED VOLUME AND LASER LINKS COULD REPLACE MOST SIGNAL AND CONTROL WIRING

Figure 3

EVA COMMUNICATIONS

Assuming extravehicular activity to a distance of 8 km from the space station, the communications requirements are very tough. As listed in figure 4, the EVA communications need to be omnidirectional, secure, and available without a tether. Two-way television communications are desirable, as is immunity from radio frequency interference. One of the main problems is frequency allocation in both radio and television bands. Blockage problems occur at the higher frequencies because of the many structures that will be built at the station. The technology options are to go higher or lower in frequency. At the upper limits, a frequency of 60 GHz will provide adequate protection against interference, but structural blockage and the multipath will be detrimental. Much lower frequencies (<1 MHz) will provide some screening from the ionosphere. This needs to be investigated as a potential application. Also, multiple antennas should be considered as an option, as should working in the near field at the lower frequencies.

PROXIMITY SYSTEMS

EVA UP TO 8 KM

POTENTIAL REQUIREMENTS

4 π STERADIANS

SECURE VOICE

TWO-WAY TV

NONTETHER (?)

MULTIPLE ACCESS

RFI IMMUNITY

CURRENT LIMITATIONS

FREQUENCY ALLOCATION AND BLOCKAGE

TV BANDWIDTH

BLOCKAGE

MAX TWO SIMULTANEOUSLY

TECHNOLOGY OPTIONS

HIGHER/LOWER FREQUENCIES

MULTIPLE ANTENNAS

COMMENTS

FREQUENCY ALLOCATION REQ PROBLEMS

OPTIMUM ANTENNAS/CONFIGURATION?

Figure 4

EXTERNAL COMMUNICATIONS

Requirements, limitations, and technology options for space station external communications (including data, voice, and video) are listed in figure 5. Data rates in the multimegabit range are needed which are just outside the range of the TDRSS. Also needed are multiple-frequency capability, simultaneous operations, dedicated-link capability, secure and antijam capability, and routing and switching capability. The two prime limitations are antenna proliferation and link availability. The Shuttle has over 20 antennas aboard and as many as 50 may be required on the space station. With the space station configuration changes and the line of sight requirement, locating 50 antennas to operate effectively will be difficult. Link availability is not absolutely continuous. There is a gap over the Indian Ocean where the link may not be available. To accommodate these high data rates and availability requirements, a dedicated TDRSS satellite with follow-on access to TDAS (Tracking and Data Acquisition System) would be helpful, if it could be afforded.

Some of the enabling technology options are to develop antennas that can handle multiple frequencies and multiple beams (e.g., offset-beam techniques, phased arrays, or variations of these techniques). The use of millimeter waves (with 60 GHz as the carrier frequency) is already under study to provide the link capability for the high data rates.

One of the problems in this area is that a great deal of information is available about the technology in classified form and this area needs to be explored.

POTENTIAL REQUIREMENTS

- MULTIPLE DATA RATE (1 KBPS TO > 1 GBPS)
- MULTIPLE-FREQUENCY CAPABILITY
- SIMULTANEOUS OPERATIONS
- MULTIPLE SPATIAL COVERAGE
- DEDICATED-LINK CAPABILITY
- SECURE ANTIJAM CAPABILITY
- ROUTING AND SWITCHING CAPABILITY

CURRENT LIMITATIONS

- DATA RATE CONSTRAINTS
- LINK AVAILABILITY CONSTRAINTS
- ANTENNA PROLIFERATION

ENABLING TECHNOLOGY OPTIONS

- MULTIFREQUENCY AND MULTIBEAM ANTENNAS
- HIGH DATA RATE SIGNAL PROCESSING/SWITCHING
- HIGH DATA RATE BUFFERS
- MM WAVE/OPTICAL LINK CAPABILITY

COMMENTS

- DEVELOPMENT OF COMMUNICATION HANDLING STRATEGIES
- DEVELOPMENT OF OPTICAL BASEBAND PROCESSING
- OBTAIN DOD TECHNOLOGY STATUS

Figure 5

NAVIGATION, TRACKING, AND RANGING

Navigation, tracking, and ranging need completely circular coverage close to the space station to a distance of about 8 kilometers, with variable range and range rate capability (fig. 6). Although there are some accuracy problems (in general, the required accuracies could be attained), range and angle resolution are actually the basic problem. Soft docking requires reducing the closing speeds to a very low rate, and the use of millimeter waves (with FM/CW systems) would measure range down to about 5 feet. A target identification system could be built into cooperative systems.

Enabling technology options include adaptive multibeam antennas, phased array, millimeter wave radar, solid-state lidar and integrated COMM/NAV or FM/CW systems.

POTENTIAL REQUIREMENTS

- MULTIPLE TARGET DISCRIMINATION
- 4π STERADIAN COVERAGE
- VARIABLE RANGE AND RANGE RATES CAPABILITY
- SOFT DOCKING
- EXTERNAL SYSTEMS HAND-OVER CAPABILITY
- AUTOMATED OPERATIONS
- TARGET IDENTIFICATION CAPABILITY

CURRENT LIMITATIONS

- NEAR-RANGE LIMITATION
- LOW VELOCITY DETERMINATION TECHNIQUES
- ABSENCE OF TARGET ATTITUDE INFORMATION
- LACK OF 4π STERADIAN COVERAGE

ENABLING TECHNOLOGY OPTIONS

- ADAPTIVE MULTIBEAM AND BEAM FORMING ANTENNAS
- MM RADAR/SOLID-STATE LIDAR
- INTEGRATED COMM/NAV SYSTEM APPROACH

COMMENTS

- FREQUENCY ALLOCATION DETERMINATION (RFI, BANDWIDTH, ETC.)
- ACCURATE MUTUAL COUPLING MODELING
- ASSUME AVAILABILITY OF GLOBAL POSITIONING SYSTEM

Figure 6

CRITICAL TECHNOLOGY ELEMENTS

The critical technology elements that were identified are listed in figure 7, along with the readiness dates. Actually, the readiness dates of 1990 and 2000 denote the dates at which it is reasonable to expect the capability to be available. These programs listed are on-going NASA programs and some augmentation is needed unless the technology can be obtained from other sources.

<u>CRITICAL TECHNOLOGY ELEMENTS</u>	<u>READINESS DATE</u>	
	1990	2000
● HIGH BANDWIDTH LINK REQUIRED MM WAVE LASER		X
● ADAPTIVE MULTIBEAM AND BEAM FORMING ANTENNAS	X	
● MM RADAR/LIDAR	X	
● INTEGRATED COMM/NAV SYSTEM DEVELOPMENT	X	
● MULTIFREQUENCY AND MULTIBEAM ANTENNAS	X	
● HIGH DATA RATE SIGNAL PROCESSING/SWITCHING		X
● HIGH DATA RATE BUFFERS		X
● SHORT RANGE LASER LINKS MODULE TO MODULE ANTENNAS TO MODULES	X	
● IR BAND EXPLOITATION	X	
● HIGH RESOLUTION, HIGH SENSITIVITY SOLID STATE TV		X
● TV COMPONENTS EQUIPMENT AUTOMATION, INCREASED INTELLIGENCE		X

Figure 7

BASELINE CRITICAL SPACE STATION COMMUNICATION LINE DEVELOPMENT ITEMS

To summarize the industry recommendations, baseline critical space station communication link development items are listed in figure 8 and ranked by priority. There was no difficulty in ranking the items relative to each other in a grouping. The main problem arose in attempting to make an overall prioritization, primarily because all of these items are really important and it is difficult to assess them collectively.

The panel felt that it was very important to eliminate the proliferation of antennas, which could be done by combining functions into one element if possible.

	PRIORITIES	
	RELATIVE	OVERALL
ANTENNA TECHNOLOGY DEVELOPMENT		
● DISTRIBUTED MULTIFUNCTIONAL/MULTIFREQUENCY ANTENNAS/COMPONENTS	3	5
● MM RADAR ANTENNAS/HYBRID COMPONENTS	2	4
● 4TT STERADIAN INTEGRATED ARRAY SYSTEM	1	1
RF COMPONENT/SUBSYSTEM DEVELOPMENT		
● HIGH TIME-BANDWIDTH HIGH POWER SOLID STATE COMPONENTS	4	
● HIGH POWER/HIGH RELIABILITY LOW COST TWT'S	1	3
● LOW NOISE NONCRYOGENIC AMPLIFIERS	5	
● LOW COST FREQUENCY SYNTHESIZERS	3	
● MANPACK MINIATURIZATION	2	6
INTEGRATED COMM/NAV DEVELOPMENT		
● ALGORITHM APPLICATION TO CIRCUIT DEVELOPMENT	2	
● INSTRUMENTATION ACCURACY AND VERIFICATION TECHNOLOGY	3	
● UP/DOWN FREQUENCY CONVERSION AND AGILE BAND PASS FILTERS	1	
OPTICAL COMPONENTS AND SUBSYSTEMS		
● SPACE QUALIFICATION	1	2
● POINTING AND ACQUISITION, AND TRACKING THROUGH BLOCKAGE	2	

Figure 8

FOLLOW-ON CRITICAL SPACE STATION COMMUNICATION LINK DEVELOPMENT ITEMS

Four major follow-on critical communication link development items were identified: video, RF component/subsystem development, signal processing and optical components, and subsystems. These items are listed in figure 9 along with the critical problem areas for each.

The integrated communications-navigation identification (ICNI type) technology is designed for tactical systems and consists of an algorithm to produce a composite wave form to perform all these functions. Some of the techniques of this concept could be applied to these critical communication needs.

VIDEO

- HIGH RESOLUTION, HIGH SENSITIVITY SOLID STATE TV
- TV EQUIPMENT AUTOMATION AND INCREASED INTELLIGENCE
 - AUTO FOCUS
 - AUTO TRACK

RF COMPONENT/SUBSYSTEM DEVELOPMENT

- HIGH BANDWIDTH LINK (MM WAVE)
 - HIGH POWER/HIGH RELIABILITY LOW-COST TRAVELLING WAVE TUBE
 - HIGH POWER/HIGH RELIABILITY LOW COST SOLID STATE
 - 120/60 GHZ ADAPTIVE BEAM FORMING

SIGNAL PROCESSING

- HIGH DATA RATE SIGNAL PROCESSING/SWITCHING
 - FOCAL PLANE TECHNOLOGY
 - AGILE BANDPASS FILTERING
- HIGH DATA RATE BUFFER
- ICNI
- ELECTRO-OPTICAL

OPTICAL COMPONENTS AND SUBSYSTEMS

- HIGH BANDWIDTH LINK
 - POINTING/TRACKING/ACQUISITION
 - HIGH POWER

Figure 9

NEAR-TERM AND FAR-TERM CONCERNS

Near-term and far-term communication technology concerns are highlighted in figure 10.

NEAR TERM CONCERNS

- BLOCKAGE AND EMI
- RELAY LINK BIT ERROR RATE RELIABILITY/AVAILABILITY/LIFE
- TRACKING OF NON-COOPERATIVE OR MISBEHAVING SATELLITES
- GROWTH CAPABILITY LIMITED, MAY REQUIRE FURTHER TDRSS/TDAS CROSS-LINK STUDIES
- FREQUENCY ALLOCATION ADEQUACY

FAR TERM

- INCOMPATIBILITY WITH MILSATCOM STANDARDS
- 60 GHz/OPTICAL RELAY REQUIRED TO HANDLE EMI AND DATA RATE
- THERMAL AND DYNAMIC LOADS ON ANTENNAS -- SELF FOCUSING ARRAYS MAY BE REQUIRED
- INTEGRATED CNI TO PERMIT MORE PAYLOAD EFFICIENT SYSTEM ARCHITECTURE, USING TODAY'S TECHNIQUES APPLIED TO OPTICAL/MM WAVE
- AUTO DOCKING VIA RELATIVE NAVIGATION FEATURES OF EXISTING CNI OR SIMILAR TECHNIQUES APPLIED TO MM WAVE AND OPTICAL
- AUTO TRACKING REQUIRED

Figure 10

INDUSTRY ASSESSMENT OF CRITICAL SPACE STATION COMMUNICATIONS TECHNOLOGIES

The critical space station communications technologies of figures 3 through 6 were assessed by the panel and are listed in figure 11 in an order representing a good compromise of opinion.

Considering the requirements for high data rates and television and communications coverage, circular coverage even out to 8 km will be difficult due to the blockage problems. Even increasing the frequency to cover the television bandwidth puts the system on the fringe of potential blocking problems. The VHF band did not provide RFI protection, but it was a good compromise between data rates and blockage. However, the VHF is not available, so additional work must be done to find a system that will meet all the requirements.

In the area of high power, TWT's are not dead, in spite of all the work on solid-state devices. Solid-state devices have a reliability of 7 to 10 years (greater than the reliability of TWT's), but TWT's can be replaced and they provide more power and are more efficient (three times that of solid state).

The millimeter band (about 60 GHz seems to be optimum for everything) is a good band. It is free from immunity and is at the approximate peak of the link budget curves. It could be improved by technology development to get good performance at 120 GHz (the next harmonic band of oxygen absorption), since performance is proportional to the square of the frequency (for fixed antenna sizes and constant losses).

A well-distributed multifunctional antenna system needs to be developed and the requirement for miniaturization is serious because the size and weight constraints are so tight.

- 4TT STERADIAN INTEGRATED ANTENNA ARRAY SYSTEM
- FLIGHT QUALIFIED OPTICAL COMPONENTS AND SUBSYSTEMS
- HIGH POWER/HIGH RELIABILITY LOW COST SPACE TWTs
- MILLIMETER WAVE RADAR ANTENNAS/HYBRID COMPONENTS
- DISTRIBUTED MULTIFUNCTIONAL/MULTIFREQUENCY ANTENNAS/COMPONENTS
- MANPACK MINIATURIZATION OF RF COMPONENT/SUBSYSTEMS

Figure 11

FLIGHT TEST REQUIREMENTS

Requirements for communications hardware flight tests are difficult to define at this time (fig. 12). However, two experiments on the Shuttle were identified to investigate some of the areas of concern. One experiment would use a radio receiver on the Shuttle to record broadcasts from Earth to check the RFI in the lower frequency bands at that altitude and determine the leakage to the top of the ionosphere. The other is an optical experiment to measure the glint and particulate scattering effects.

- 0 EXAMINE THE RFI ENVIRONMENT BY MONITORING LF, MF, HF BROADCAST STATIONS FROM SHUTTLE.

- 0 EXAMINE THE GLINT AND PARTICULATE SCATTERING EFFECTS FROM THE SHUTTLE TO DEFINE POTENTIAL LASER COMMUNICATIONS PROBLEMS

- 0 HARDWARE FLIGHT TEST REQUIREMENTS DIFFICULT TO DEFINE AT THIS TIME.

Figure 12

RECOMMENDATIONS

Recommendations made by the communications panel are listed in figure 13. NASA should form a space station communications working group comprised of representatives from industry, university, DOD, and NASA. The working group should interface with other working groups and coordinate outputs from these groups. As in almost any project, funding is inadequate and may have an adverse impact on the operational readiness of the space station program. More specificity is required on the space station communication architecture. Possibly a series of architectures should be developed: a very near term, a midterm and a far term. The panel also strongly recommended a follow-on workshop after the results from the current workshop and data from ongoing studies have been assimilated and assessed. The impact of NASA programs on space station activities in industry and DOD needs to be assessed.

- FORM NASA/INDUSTRY/UNIVERSITY/DOD SPACE STATION COMMUNICATIONS WORKING GROUP
- COORDINATE OUTPUTS OF OTHER WORKING GROUPS
- FUNDING IN THIS AREA IS INADEQUATE AND ADVERSELY IMPACTS THE OPERATIONAL READINESS OF THE SPACE STATION PROGRAM
- MORE SPECIFICITY REQUIRED ON SPACE STATION ARCHITECTURE
- FOLLOW-ON SPACE STATION WORKSHOP AFTER DATA FROM STUDIES AND INITIAL WORKSHOP HAVE BEEN ASSESSED
- ASSESS IMPACT OF NASA PROGRAM OFFICES' COMMUNICATION ACTIVITIES ON THE SPACE STATION

Figure 13

STRUCTURES AND MECHANISMS

David Purdy
General Electric Company
Philadelphia, Pennsylvania

Space Station Technology Workshop
Williamsburg, Virginia
March 28-31, 1983

INTRODUCTION

Structures, materials, and mechanisms is one of the older technologies in the aerospace business. The Structures, Materials, and Mechanisms Panel was divided into the four basic categories that fit the overall responsibilities of the panel, as shown in figure 1.

- 0 MATERIALS
- 0 MECHANISMS
- 0 STRUCTURAL DESIGN
- 0 ANALYSIS

Figure 1

F.Y. 1983 MATERIALS AND STRUCTURES BUDGET

There is already a good-sized structures and materials program within NASA, spending about \$14.7 million a year in space-related structures and materials activities, with about \$3.7 million designated specifically for space station type activities. The budget, by category, is shown in figure 2 for the five major structures and materials thrusts.

THRUSTS (THOUSANDS OF DOLLARS)	SPLIT BY CATEGORY				
	<u>BASIC</u>	<u>STS</u>	<u>SPACECRAFT</u>	<u>SPACE PLATFORM</u>	<u>TOTAL</u>
MATERIALS SCIENCE	2520	-	-	-	2520
SPACE DURABLE MATERIALS	1225	170	353	1015	2763
ADVANCED TPS	200	2755	-	-	2955
ADVANCED SPACE					
STRUCTURES	300	400	1982	1000	3682
ANALYSIS AND SYNTHESIS	100	750	200	1735	2785
	—	—	—	—	—
TOTAL	4345	4075	2535	3750	14705

Figure 2

GENERAL COMMENTS

Some general comments that were present throughout the panel deliberations are listed in figure 3. The general need for ongoing systems engineering to establish baselines, focus technical activities, control interdisciplinary issues, and establish preliminary criteria was identified. Among the issues that arose were survivability of debris in space and radiation protection. These and other issues led to the conclusion that for ongoing system engineering activity, looking at cross disciplines and handling preliminary requirement issues would be beneficial in focusing the technology activities. In the interdisciplinary issues, where the structures interface between power and thermal technologies, the need to tie the requirements, trends, and trades together must be clearly focused. The technology focus in structures and materials within NASA has not been brought to bear entirely on the space station activity. For example, of the \$14.7M in structures and materials, only about 10 percent is specifically traceable to space station activities in materials. A general trend to provide more emphasis and focus on some of the near-term problems is needed.

There will be a large number of motors, separation devices, and major mechanisms (berthing and docking) throughout the space station. It is important to realize that there is an even larger number of connectors, doors, latches, hinges, and motors which occur everywhere. There is an opportunity for considerable improvement in the space station activity with a good overall mechanism system study that would (1) perhaps redirect some of traditional mechanisms approaches, and (2) provide for some commonality in systems where possible. Many mechanisms come from third- and fourth-tier vendors, who are often left to make their own trades and decisions in these areas. Also, there is the issue of retaining the traditional redundancy in mechanisms when the repairability capability is near at hand. Although there is much work to be done, there are no "show stoppers."

The final general concern revolves around the mechanism for transferring a lot of the technology activities, particularly the base technology and analytical technology activities, into the hardware community.

- o GENERAL NEED FOR ON-GOING SYSTEMS ENGINEERING
 - o ESTABLISH BASELINES
 - o FOCUS TECHNOLOGY ACTIVITIES
 - o CONTROL INTERDISCIPLINARY ISSUES
 - o ESTABLISH PRELIMINARY CRITERIA

- o TECHNOLOGY PROGRAMS HAVE NOT YET EMPHASIZED SPACE STATION
 - o 10% OF MATERIAL TECHNOLOGY BUDGET SPACE STATION ORIENTED
 - o MOST PROGRAMS GENERIC NOT SPECIFIC

- o POTENTIAL IDENTIFIED FOR MAJOR COST AND UTILITY SAVINGS WITH COMMON/IMPROVED MECHANISMS
 - o MECHANISM SYSTEMS STUDY NEEDED
 - o CONNECTIONS, POWER TRANSISTOR, MOTORS, DEPLOYMENT, SEPARATION DEVICES AND DOCKING/BERTHING MECHANISMS

- o NO SHOW STOPPERS

- o TECHNOLOGY TRANSFER MECHANISMS FROM BASE TO APPLIED NOT DEFINED

Figure 3

INTERDISCIPLINARY ISSUES

The panel spent considerable time working on the interdisciplinary issues with representatives from the other panels. The key interdisciplinary issues between structures and the power, thermal, and controls technologies are listed in figure 4. The structures-power issue involved systems engineering in the solar array development to ensure that all the structural, weight, and trade issues were addressed in the solar array concept selection. In the thermal area, the principal concern involved the need for a deployable radiator, which potentially would rotate. Structurally, the radiator could be made stiff enough. Many materials problems would be solved; rotation would keep the coatings out of the Sun and eliminate radiator degradation. There were "no major issues" in the structures-controls interface.

POWER

- o STRUCTURAL ENGINEERING SUPPORT REQUIRED IN SOLAR ARRAY DEVELOPMENT

THERMAL

- o STRUCTURES PANEL CONCERNED ABOUT DEPLOYABLE ROTATING RADIATOR

CONTROLS

- o NO MAJOR ISSUES; INTERDISCIPLINARY PANEL IN PLACE

CONCLUSION

- o SYSTEM ENGINEERING REQUIRED

Figure 4

MATERIALS TECHNOLOGY TASKS

The ongoing technology activity in materials is divided into the areas of structural materials, material durability, coatings, windows, and shielding, as listed in figure 5.

- o STRUCTURAL MATERIALS
 - o METALS AND METAL MATRIX COMPOSITES
 - o POLYMER MATRIX COMPOSITES
 - o HIGH PERFORMANCE POLYMERS

- o MATERIALS DURABILITY
 - o RADIATION STABILITY OF POLYMERS AND COMPOSITES
 - o DIMENSIONAL STABILITY OF COMPOSITES
 - o SPACE DEBRIS
 - o FATIGUE AND FRACTURE
 - o NDE

- o COATINGS
- o WINDOWS
- o SHIELDING

Figure 5

MATERIALS TECHNOLOGY

There are some fairly unique requirements in the materials technology area for the space station (fig. 6). For the long-life issue, the development of coatings with extended life presents problems of radiation degradation of the material, survival of the coating, and renewability of the coating. Other issues are the radiation limit for the long-term presence of man in space and the unique environmental concern of low-Earth orbit (LEO). Although there is considerable ongoing activity in base technology and space-station-related technology in materials, the level of activity should be increased in several key areas. The thermal controls coating issue involves the constant problems of long-term stability, the high cost of existing coating procedures, the renewability of coatings, and the atomic oxygen degradation. Spaceborne debris, especially in the low-altitude environment, is not only a materials issue but also a structures issue in terms of survivability, impact damage, resistance, and pressure containment.

● UNIQUE SPACE STATION REQUIREMENTS

- LONG LIFE (20-30 Yrs)
- LONG TERM PRESENCE OF MAN IN SPACE (RADIATION LIMIT)
- LEO ENVIRONMENT

● NEW* DEVELOPMENT NEEDED

- THERMAL CONTROL COATINGS WITH LONG TERM STABILITY CONTAMINATION RESISTANCE AND/OR IN-SPACE RECOATING
- THERMAL CONTROL FILMS THAT ARE ATOMIC OXYGEN HARDENED (REPLACEMENT FOR KAPTON)
- ATOMIC OXYGEN CHARACTERIZATION AND TEST (ADD GROUND TEST CAPABILITY)
- DEFINE DEBRIS DENSITY, SIZE, & NUMBER
- DEVELOP DEBRIS IMPACT RESISTANT MATERIALS
 - HIGH TOUGHNESS
 - SELF SEALING
 - REPAIR AND REPLACEMENT MATERIAL IMPACTS
 - CHARGE PROTECTION

* NEW OR MORE EMPHASIS COMPARED TO EXISTING WORK

Figure 6

THERMAL CONTROL COATINGS TECHNOLOGY

In the area of thermal control coatings (fig. 7), the existing work on long-life coatings and contamination of coatings needs to be increased. The current state-of-the-art readiness of blankets is important to the whole space station activity. There are coatings under development for blankets, some of which apparently are demonstrating the ability to survive the atomic oxygen environment for a short duration. These are many unknowns and all of the coating issues need to be worked. There will be a need for other types of coatings on the space station. For example, a truss-type structure would need a low emittance coating since blankets would not be appropriate.

The LDEF, which is scheduled to fly in the near future, will hopefully provide some additional useful data in this materials arena.

- o EXISTING PLANS - RECOMMENDATIONS
 - INCREASE RESEARCH PROGRAM IN LONG-LIFE COATINGS
 - INCREASE EFFORT ON CONTAMINATION OF COATINGS

- o DEVELOPMENT REQUIRED FOR INITIAL SPACE STATION DESIGN
 - REQUALIFICATION OF S-13GLO AND ZOT WITH NEW SILICONE RESIN
 - DEVELOP LOW-EMITTANCE COATING FOR COMPOSITE STRUCTURES
 - DEVELOP REPAIR/REFURBISHMENT PROCEDURES FOR COATINGS

- o CURRENT STATE-OF-TECHNOLOGY READINESS
 - MULTILAYER INSULATION BLANKET AND PAINTS ARE BEING USED
 - LOW-EMITTANCE

- o LEVEL OF READINESS REQUIRED FOR INCORPORATION INTO SPACE STATION
 - LONG-LIFE SPACE QUALIFIED COATINGS ESSENTIAL AND/OR PROVEN REPAIR/REFURBISHMENT PROCEDURES ESTABLISHED

- o FIGHT TESTS REQUIREMENTS
 - LDEF
 - STS-11 (ATOMIC OXYGEN)
 - "PIGGY BACK"

Figure 7

SHIELDING TECHNOLOGY

Shielding is an issue for the materials community and the principal concern is the requirements. Some of the issues on which the requirements will be based are listed in figure 8. The radiation problem, and hence the shielding requirement, is orbit dependent, mission dependent, and time dependent.

- 0 RADIATION EXPOSURE WILL LIMIT THE MAXIMUM TIME AN ASTRONAUT CAN SPEND PER YEAR AT SPACE STATION
- 0 MAJOR SOLAR PARTICLE EVENTS POSE A SIGNIFICANT HEALTH HAZARD TO ASTRONAUTS
- 0 STORM SHELTERS REQUIRED
- 0 EARLY WARNING SYSTEM NECESSARY
- o REAL TIME RADIATION MONITOR REQUIRED TO DETECT CHANGE IN INTEGRATED TRAPPED RADIATION

Figure 8

RADIATION EXPOSURE EXAMPLE

An example of the radiation exposure problem is shown in figure 9. The example is for a 300-mile orbit with a 57-degree inclination with the levels of exposure that would be experienced in the south Atlantic anomaly area. From the chart, it is shown that acceptable dose limits (even with fairly reasonable or available types of shielding) are exceeded in a fairly short time.

THIRTY DAY EXPOSURE LIMITS

	Marrow	Skin	Lens	Testes
rem	25	75	37	13
rad*	19.2	57.7	28.5	10

*DE \approx 1.3D where DE is the dose equivalent and D is the dose.

TIME REQUIRED TO REACH EXPOSURE LIMITS FOR AUGUST 4 EVENT

Shield, g/cm ²	Marrow, hr	Skin, hr	Lens, hr	Testes,* hr
0.2	6.0	3.0	1.9	4.4
.4	6.1	3.5	2.4	4.9
1	6.3	4.7	3.6	5.2
5	8.9	8.0	6.5	7.3
10	∞	∞	11.7	12.7

*Values are overestimated since the testes dose is taken to be the same as the marrow dose.

Figure 9

MECHANISMS TECHNOLOGY

There will be a large number of mechanisms, both large and complex as well as small and simple, on the space station. A list of mechanisms is given in figure 10.

- 0 DEPLOYMENT DEVICES
- 0 POINTING DEVICES
- 0 DOCKING/BERTHING SYSTEMS
- 0 UMBILICAL DISCONNECT DEVICES
- 0 DOOR AND HATCH , HINGES , ACTUATORS , LATCHES , SEALS
- 0 RETENTION/RELEASE DEVICES
- 0 MANIPULATORS , HANDLING AIDS
- 0 GRASPING DEVICES
- 0 TOOLS
- 0 JOINTS, STRUCTURAL INTERFACES

Figure 10

MECHANISM REQUIREMENTS

The requirements for the mechanisms on the space station are the same as for any spacecraft. These requirements include long life, predictable life, high reliability, variability, precision of function, and low cost, as shown in figure 11.

- 0 LONG LIFE, PREDICTABLE LIFE
- 0 HIGH RELIABILITY
- 0 VARIABILITY OF FUNCTION
- 0 PRECISION OF FUNCTION
- 0 LOW PROGRAM COSTS

Figure 11

MECHANISMS TECHNOLOGY PROGRAM

The mechanical technology program encompasses three areas: mechanical elements, mechanical systems, and analysis design. Each of the activities and associated plans listed in figure 12 was discussed. There was a major concern over using robotics to perform a mechanical function, but it appears that there is potential for effective use of mechanisms managed by sensing systems and controlled through a computer.

- o MECHANICAL ELEMENTS
 - SEALS
 - LUBRICANTS
 - POWER TRANSMISSION (ROLLER DRIVE)
 - LATCHES/CONNECTORS/UMBILICALS
 - SMART MECHANISM CONCEPTS

- o MECHANICAL SYSTEMS
 - DEPLOYMENT/ASSEMBLY DEVICES
 - REMOTE MANIPULATOR (SPACE CRANE)
 - DOCKING/BERTHING

- o ANALYSIS AND DESIGN
 - KINEMATICS/RELIABILITY ANALYSIS

Figure 12

GENERAL COMMENT ON MECHANISM TECHNOLOGY

The principal comment relative to mechanism technology was that it was unfunded (fig. 13). The panel concluded that there was a potential for real savings (in terms of cost and usability of the space station) which would go beyond just doing some mechanical technology and developing better mechanisms, as well as an opportunity to develop new approaches and commonality among the many mechanisms. This would make a significant impact on this activity. A systems level study of the use of mechanisms (types, power required, type of force dispersed) should be undertaken to define recommendations for what should be developed and how.

- o ZERO FUNDING FOR MECHANISMS IS NOT APPROPRIATE
- o VAST QUANTITY OF MECHANISMS ON SPACE STATION OFFER POTENTIAL
FOR STANDARDIZATION AND NEW APPROACHES
- o OVERALL SYSTEMS STUDY NEEDED, FOLLOWED BY TECHNOLOGY PROGRAMS

Figure 13

TECHNOLOGY NEEDS FOR SMART MECHANISM CONCEPT

The microprocessor gives a new dimension to mechanism control and will drastically alter design philosophy (fig. 14). The smart mechanism provides the opportunity for potentially decreasing workload and taking advantage of the kind of capability that is coming on line in terms of sensors and micro-computer control. A wide variety of functions can be performed, including docking, attenuators, actuators, sensing, and pointing.

- o MICROPROCESSORS GIVE NEW DIMENSION TO MECHANISM CONTROL, WILL DRASTICALLY ALTER DESIGN PHILOSOPHY WITH REGARD TO:
 - REDUNDANCY, FAULT SENSING, FAILURE TOLERANCE
 - VARIABILITY OF FUNCTION
 - PRECISION OF FUNCTION
 - MECHANICAL DESIGN
- o THE SPACE STATION WILL NEED SMART MECHANISMS TO ACCOMMODATE:
 - WIDELY VARIED PERFORMANCE REQUIREMENTS, SUCH AS FOR DOCKING ATTENUATORS/ACTUATORS
 - PRECISION IN SENSING/POINTING ACTUATORS
 - REQUIREMENTS FOR LONG LIFE, PREDICTABLE LIFE, SELF TESTING AND FAULT DETECTION
 - COMMONALITY TO SIMPLIFY AND REDUCE EXPENSE OF SPARES, PROGRAM DEVELOPMENT COSTS

Figure 14

SMART MECHANISM BLOCK DIAGRAM

A block diagram of the smart mechanism is presented in figure 15 to show the fairly low programming, simple approach.

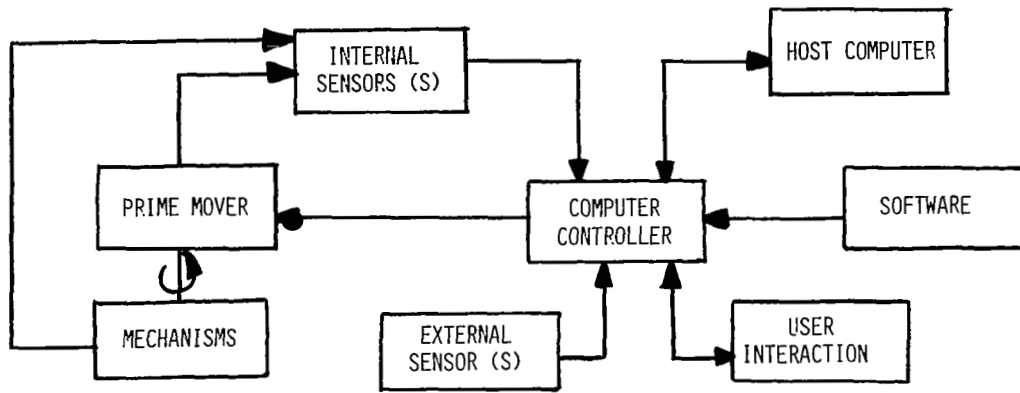

Figure 15

STRUCTURAL DESIGN TECHNOLOGY

In the structural design area, the nine ongoing technology activities listed were reviewed (fig. 16). Previous manned flights indicated a need for dialogue between the acoustics, human factors, and structures and dynamics technologies to address interdisciplinary issues (to determine from each perspective if there is a problem).

- o LONG TERM STRUCTURAL INTEGRITY OF PRESSURE VESSELS
- o SOLAR ARRAYS
- o DEPLOYABLE STRUCTURES
- o OTV HANGAR (WORK ENCLOSURE)
- o ERECTABLE STRUCTURES
- o CRYOGEN STORAGE
- o MODULE MANIPULATION/ASSEMBLY
- o THERMAL RADIATORS
- o ACOUSTICS

Figure 16

STRUCTURAL DESIGN GENERAL COMMENTS

The general comments relative to structural design activity pertain primarily to the development of preliminary requirements and initial design criteria (fig. 17). It is difficult to steer the technology activities with all the options still open. The technology community needs to revisit the space station at regular intervals as it develops, and the technology activities must be flexible enough to refocus if required. The most significant item to the structures community is the unknowns and potentials in the debris area. Many open questions remain in this area, such as how much protection is needed, what type of protection (bumpers), size and velocity of debris, and probability of hits. Many of the structural possibilities under consideration may require flight tests to validate construction and assembly techniques.

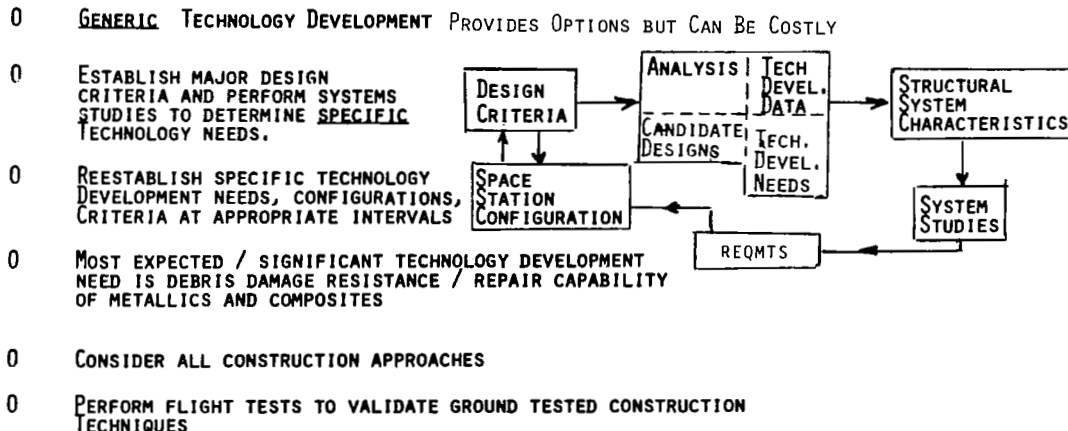

Figure 17

LONG-TERM STRUCTURAL INTEGRITY OF PRESSURE VESSELS

In terms of current state of the art for long-term structural integrity of pressure vessels (fig. 18), damage resistant constructions are not developed. Since the space debris hazard is not well defined, the requirements issue must be addressed and damage resistant concepts studies must be initiated.

RECOMMENDATIONS ON EXISTING PLANS

- o INITIATE STUDIES OF DAMAGE RESISTANT CONCEPTS

CURRENT STATE OF TECHNOLOGY READINESS

- o CURRENT STATE-OF-THE-ART MODULE WALL DESIGNS, AS BUILT, CAN SURVIVE THE DIFFERENTIAL PRESSURE-IMPOSED STRESS SPECTRUM FOR 20 YEARS AND SATISFY MINIMUM LEAKAGE REQUIREMENT
- o SPACE DEBRIS HAZARD NOT WELL DEFINED AND LONG TERM DAMAGE RESISTANT CONSTRUCTIONS NOT DEVELOPED

LEVEL OF READINESS REQUIRED FOR INCORPORATION INTO SPACE STATION

- o PROTOTYPE DAMAGE RESISTANT MODULES MUST BE GROUND TESTED UNDER SIMULATED CONDITIONS

FLIGHT TEST REQUIREMENTS

- o NONE

Figure 18

STRUCTURAL DESIGN ISSUES

Current structural design activity is summarized in figure 19 for various construction options for space station structural components. Although the favorite activity in the structures community appears to be the large deployable or erectable structures, the development status of complex truss work deployment is not very far along. The unknowns in the deployable area (joint complexity, interactions required), and hence the probability of successful deployment, leave a question as to whether or not the technology will be ready.

STRUCTURAL COMPONENT	CONSTRUCTION OPTION			
	WELDED TANK	DEPLOYABLE	ERECTABLE	INFLATABLE
HABITAT MODULE	X			
LOGISTICS MODULE	X			
SOLAR ARRAYS		X		X
PLATFORMS		X	X	
OTV HANGARS		X	X	X
THERMAL RADIATORS		X		
CONSTRUCTION AIDS		X		
PROPELLANT STORAGE	X			
FREE FLYERS	X	X		
ANTENNAS		X	X	

Figure 19

DEPLOYABLE TRUSS STRUCTURES

In the deployable truss area, the existing plans need to be expanded to include space-station-like ground test components. The current state of technology readiness, readiness level, and flight test requirements are listed in figure 20.

RECOMMENDATIONS ON EXISTING PLANS

- o EXPAND BASE PROGRAM TO INCLUDE SPACE-STATION-LIKE GROUND TEST COMPONENT

CURRENT STATE OF TECHNOLOGY READINESS

- o TRUSS CONCEPTS FORMULATED
- o DEPLOYMENT TECHNIQUES FORMULATED

LEVEL OF READINESS REQUIRED FOR INCORPORATION INTO SPACE STATION

- o PROTOTYPE TRUSS STRUCTURE MUST BE GROUND TESTED UNDER SIMULATED CONDITIONS

FLIGHT TEST REQUIREMENTS (DESIRED OR MANDATORY)

- o FLIGHT DEPLOYMENT TEST WOULD BE DESIRABLE

Figure 20

ERECTABLE TRUSS STRUCTURE

In the erectable truss area, the existing base program needs to be expanded to include flight joints and struts, a prototype structure, and space assembly tests. The current state of technology readiness, readiness level, and flight test requirements are listed in figure 21.

RECOMMENDATIONS ON EXISTING PLANS

- o CONTINUE BASE PROGRAM TO INCLUDE FLIGHT JOINTS AND STRUTS
- o EXPAND BASE PROGRAM TO INCLUDE A PROTOTYPE STRUCTURE AND SPACE ASSEMBLY TESTS

CURRENT STATE OF TECHNOLOGY READINESS

- o STRUCTURAL CONCEPTS WELL DEVELOPED
- o JOINT CONCEPTS WELL DEVELOPED
- o ASSEMBLY TECHNIQUES MODERATELY DEVELOPED

LEVEL OF READINESS REQUIRED FOR INCORPORATION INTO SPACE STATION

- o PROTOTYPE STRUCTURES SHOULD BE BUILT AND TESTED
- o ASSEMBLY STUDIES SHOULD BE CONDUCTED IN SPACE

FLIGHT TEST REQUIREMENTS (DESIRED OR MANDATORY)

- o ASTRONAUT ASSEMBLY TESTS ARE MANDATORY

Figure 21

ANALYSIS AND SYNTHESIS

Key ongoing activities in the analysis and synthesis area are listed in figure 22.

- ADVANCED STRUCTURAL DYNAMICS ANALYSIS
- VIBRATION CONTROL
- OPTIMIZATION
- INTEGRATED THERMAL-STRUCTURAL ANALYSIS
- ENGINEERING DATA BASE MANAGEMENT

Figure 22

ANALYSIS AND SYNTHESIS GENERAL COMMENTS

The development of an engineering data base management system is a significant analysis item for the space station (fig. 23). The development of advanced structural dynamic analysis methods is needed to provide options that will improve the analysis of the vehicle and broaden the design growth. The benefits of integrated thermal structures analysis need to be assessed, including the value of combining the modeling and analysis activities of thermal and structures. The benefits of damping will be an issue for the space station and the technology will need to be developed, if required.

- ENGINEERING DATA MANAGEMENT KEY ITEM FOR SPACE STATION LONG TERM
- ENHANCED DYNAMIC ANALYSIS PERMITS BROADER GROWTH DESIGN OPTIONS
- BENEFITS OF COMBINED THERMAL/STRUCTURAL ANALYSIS TO SPACE STATION SHOULD BE ASSESSED
- ESTABLISH BENEFITS TO SPACE STATION OF PASSIVE DAMPING AND DEVELOP TECHNOLOGY AS REQUIRED

Figure 23

ADVANCED STRUCTURAL DYNAMIC ANALYSIS

The prospects for a long-term evolutionary space station heighten the need for reliable advanced analysis and design of analyzable systems. Technology issues and advantages of the advanced analysis capability are listed in figure 24.

PROSPECTS FOR A LONG-TERM EVOLUTIONARY SPACE STATION HEIGHTEN THE NEED FOR RELIABLE ADVANCED ANALYSIS AND FOR DESIGN OF ANALYZABLE SYSTEMS.

TECHNOLOGY ISSUES:

- PRACTICAL INTEGRATED ANALYSES ARE NEEDED FOR LARGE MOTIONS OF FLEXIBLE ORBITAL SYSTEMS. DESIGN MUST ACCOUNT FOR PREDICTABILITY AS WELL AS FUNCTION.
- LACK OF GROUND VERIFICATION OF EVOLUTIONARY SYSTEM DICTATES INCREASED RELIANCE ON ANALYSIS

REASONS FOR NEED:

- EFFECTS OF LARGE CHANGES IN MASS AND CONFIGURATION MUST BE UNDERSTOOD FOR MISSION PERFORMANCE AND CREW SAFETY.
- BECAUSE SYSTEM IS EVOLUTIONARY, GROUND VERIFICATION OF ALL CONFIGURATIONS IS LACKING; THUS INCREASED CONFIDENCE IN ANALYSIS MUST BE GENERATED.

ADVANTAGES:

- VERIFIED ANALYSIS CAPABILITY ALLOWS MISSION PERFORMANCE WITH INCREASED CONFIDENCE AND EFFICIENCY.

Figure 24

VIBRATION CONTROL

Vibration control technology, including system identification, is needed to assure crew safety and the success of scientific experiments. Technology issues for vibration control are listed in figure 25.

VIBRATION CONTROL TECHNOLOGY INCLUDING SYSTEM IDENTIFICATION IS NECESSARY TO ASSURE CREW SAFETY AND SUCCESS OF SCIENTIFIC EXPERIMENTS.

TECHNOLOGY ISSUES:

- CAPABILITY FOR GLOBAL VIBRATION CONTROL, VERIFICATION OF STABILITY, AND DESIGN FOR MISSION PERFORMANCE OF LARGE EVOLUTIONARY SYSTEM IS NECESSARY.
- RELIABLE ACTUATION/SENSING SYSTEMS ARE NOT IN HAND.
- CAPABILITY FOR ON-ORBIT IDENTIFICATION OF STRUCTURAL DYNAMICS CHARACTERISTICS IS NECESSARY

REASONS FOR NEED:

- CREW SAFETY REQUIRES THAT ALL ACTIVE SYSTEMS BE STABLE; THUS ANALYSES FOR CLOSED-LOOP STABILITY MUST BE ACCURATE.
- ACTIVE VIBRATION CONTROL CAN BE ACHIEVED ONLY IF RELIABLE, PREDICTABLE ACTUATORS/SENSORS ARE AVAILABLE.
- CHANGES OF PROPERTIES WITH TIME AND CONFIGURATION MUST BE ASCERTAINED.

Figure 25

CONCLUSION

To meet the challenge of a "permanent" space station, structures and materials technology needs to be sharpened and focused on the station program as the system is better understood and the requirements and criteria are better defined. A number of issues were addressed in the structures, materials, and mechanisms areas.



DATA MANAGEMENT

Glen Love
McDonnell Douglas Astronautics Company
Huntington Beach, California

Space Station Technology Workshop
Williamsburg, Virginia
March 28-31, 1983

DATA MANAGEMENT PANEL

The data management panel was divided into three major areas: systems and software, processors and memory, and networks (fig. 1).

- SYSTEMS AND SOFTWARE
BILL MADDEN - IBM

- PROCESSORS AND MEMORY
DR. JAY PATEL - HONEYWELL

- NETWORKS
TOM VAN DER HEYDEN - SPACE
COMMUNICATIONS

- 25 NASA AUTHORS

- 50 INDUSTRY REPRESENTATIONS

Figure 1

STATE OF THE ART

The panel assessed the state of the art in each of the three data management technology areas and projected what the state of the art would be in the 1987 timeframe (fig. 2). In the flight hardware areas, computer throughput (the number-crunching capability) and memory capability (the amount of information stored within on-line or off-line mode) need to be increased. Since the number of experiments and analysts is increasing, the current capability is being utilized and there is no margin left for expansion. The fault tolerance area is very embryonic at this time. No matter how much information is put on a data bus, there is always a requirement for additional information. Although the space station must have the ability to add to the data base, the ability to add to the data base without overloading them is needed. Space qualification of computers and memory to do the job for the space station in the required timeframe is a requirement.

The current software shortcomings are not in generating the software, but in generating the requirements clearly enough so that when they are mechanized in computer code, they will solve the right problem. Many tools are available to tell that the computer code is working, but the ability to get the code to do the right job is really the most significant problem. In developing software, only 15 percent of the work is related to generating the code; the balance has to do with requirements. Actually, the development tools are inadequate for the volume of software projected both for the 1990 timeframe and to react to on-board changes. Also, the system testing instrumentation is poor. Computers are little black boxes with a connector, and it is impossible to see what's going on inside.

The data base management architecture and its test ability (setting up the architecture so that something can be added without creating a problem some other place down the line) need to be developed. The evolution and graceful growth and the fault tolerance for these architectures is very embryonic. Every group wants its own computer, so an architecture that will accommodate them all must be developed. The conclusion is that the space station needs a distributive system.

- CURRENT FLIGHT HARDWARE SHORTCOMINGS
 - COMPUTER THROUGHPUT AND MEMORY CAPACITY
 - EMBRYONIC FAULT TOLERANCE
 - COMPUTER-TO-COMPUTER-TO GROUND INTERFACE (DATA BUSES) DATA RATE
 - SPACE QUALIFICATION
 - CURRENT SOFTWARE SHORTCOMINGS
 - REQUIREMENTS GENERATION/CLARITY
 - DEVELOPMENT TOOL INADEQUACY
 - SYSTEM TESTING INSTRUMENTATION POOR
 - DATA MANAGEMENT ARCHITECTURE
 - TESTABILITY
 - EVOLUTION/GRACEFUL GROWTH
 - FAULT TOLERANCE
- } EMBRYONIC

Figure 2

1987 TECHNOLOGY PROJECTIONS

Projecting the technology to 1987 (fig. 3) indicates no problems with providing adequate throughput. (This is being done by industry, funded by DOD.) The data capacity and memory data base are heading in the direction of fiber optics, which may increase rates to the gigabit level. Radiation hardening is an issue that is being addressed indirectly for the space station type of requirements. Most of this work is being done in conjunction with efforts associated with ballistic missile defense, but the fallout from these programs should be quite adequate for the space station environment. The distributed architecture for the 1987 timeframe will go from a mainframe to a microprocessor. The microprocessor could be down to the personal computer type of capability that would be required in the distributive system of the space station. Fault tolerance of critical systems will permit detection of faults and self-correction of the fault in orbit. Many more software development tools will be available by 1987. Several DOD systems are under development and should mature to the point that they would be able to fit into the NASA space station program.

- INCREASED CAPABILITY
THROUGHPUT
DATA CAPACITY - MEMORY/DATA BUS
- RADIATION HARDNESS
- DISTRIBUTED ARCHITECTURE
RANGES MAINFRAME TO MICROPROCESSOR
- FAULT TOLERANCE
- MORE SOFTWARE DEVELOPMENT TOOLS

Figure 3

CURRENT TECHNOLOGY FOR PROCESSORS/STORAGE

In terms of current technology for processors and storage (fig. 4), general-purpose processors with 1.5 million instructions per second are available now and computers with that capability which are flyable are available. There are several signal processors available which provide capabilities somewhere between 10 and 100 million instructions per second. The architecture of signal processors is usually tailored to the particular application, so that a given signal processor, if moved from one fast Fourier transform (FFT) to another, would not achieve the same throughput capability.

There are several viable technologies in the mass storage area. The bubble memory system is not flight proven. There are some problems with the temperature range which must be overcome before this system is viable for a space station. The magnetic disc system has not been flight proven either. Optical discs are read-only devices but can store large amounts of information. The old standby magnetic tape systems is the most mature system and has been flight proven. Its only problem is the high life cycle cost.

- GENERAL-PURPOSE PROCESSORS (SINGLE PROC. ELEMENT)
 - 1.5 MIPS (MILLION INSTRUCTIONS PER SECOND)
(FIXED POINT INSTRUCTIONS)

- SIGNAL PROCESSORS
 - 10 MIPS TO 100'S OF MIPS (FUNCTION OF TYPE OF SIGNAL PROCESSORS AND NUMBER OF PROCESSING ELEMENTS)

- MASS STORAGE (VIABLE TECHNOLOGIES)
 - BUBBLE MEMORIES: NOT FLIGHT PROVEN
 - MAGNETIC DISCS: NOT FLIGHT PROVEN
 - OPTICAL DISCS: READ-ONLY DEVICES
 - MAGNETIC TAPE: FLIGHT PROVEN, MOST MATURE, HIGH LIFE CYCLE COST

Figure 4

1987 PROJECTIONS FOR PROCESSORS/STORAGE

Projecting the technology to 1987 (fig. 5) shows the processor number-crunching capability increasing to 6 to 10 million instructions per second (MIPS). This is due to VHSIC (very high speed integrated circuit) technology going down to the lower feature sizes in the generation of the integrated circuits. Signal processor capability will jump an order of magnitude (100 to 1000 MIPS), again lowering feature sizes to increase the throughput capability and speed. With a little help, bubble memories will be qualified. However, each storage system has a disadvantage to go with each advantage. Where the memory is virtually unlimited, the access time is limited (bubble memory, magnetic, and optical disc). The magnetic tape has the highest storage and access time, but tape involves a waiting time until the tape reaches the end of the reel.

Virtual memory is a requirement for space station data storage. The analyst must have the capability of writing a computer program, talking about data sets, and manipulating the data sets without being concerned about specific memory locations and size limitation. The bubble memory will probably provide a solution to the off-line storage problem.

- GENERAL-PURPOSE PROCESSORS (SINGLE PROCESSING ELEMENT)
 - 6 TO 10 MIP (FIXED POINT INSTRUCTIONS)

- SIGNAL PROCESSORS
 - 100's TO 1000'S MIPS (FUNCTION OF TYPE OF SIGNAL PROCESSORS AND NUMBER OF PROCESSING ELEMENTS)

- MASS STORAGE
 - BUBBLE MEMORIES: POTENTIAL VIRTUAL MEMORY
MEDIUM ACCESS TIME, MEDIUM STORAGE
 - MAGNETIC DISCS: POTENTIAL VIRTUAL MEMORY
MEDIUM ACCESS TIME, MED-HIGH STORAGE
 - OPTICAL DISC: NON-ERASABLE, MED-HIGH ACCESS TIME, HIGH STORAGE
 - MAGNETIC TAPE: OFF LINE MASS STORAGE, HIGH ACCESS TIME,
HIGHEST STORAGE

Figure 5

PROCESSING TALL POLES

Looking at the tall poles (largest problems) associated with processing (fig. 6), the most important item is development of a fault-tolerant computer. This computer must possess the capability to detect a problem and resolve that problem by either switching in another computer or having some type of self-healing capability in the distributive system. DOD is farther along in the area of standardization than NASA. DOD has an existing standard 16-bit processor and a standard 32-bit processor in the early development stage. The panel unanimously recommended that the space station have standardization at the core level. Standardization is not required for the experiments (many users would be lost), but standardization for the interconnects to the space station should be developed.

- FAULT-TOLERANT COMPUTERS

- STANDARDIZATION

- SPACE STATION DATA STORAGE REQUIREMENTS
 - VIRTUAL MEMORY
 - OFF-LINE STORAGE

- INSERTION OF VHSIC TECHNOLOGY

Figure 6

PRIORITIZATION OF PROCESSOR TASKS

The on-going NASA tasks related to processors are prioritized on a functional basis along with additional tasks that the panel considered important (fig. 7). The Instruction Set Architecture (ISA) selections study was ranked first because it is extremely important that NASA take a position on this very early in the program. The signal processing architecture study was added because NASA has an on-going program of very high speed information processing leading to chip set development and the total program should have some firm requirements before it goes too far downstream.

- ISA SELECTION STUDY - ADDED TASK
- FAULT-TOLERANT COMPUTER VALIDATION
- FAULT-TOLERANT/CONCURRENT MICROPROCESSORS
- SPACE-RADIATION-HARDENED MICROCIRCUITS
- SIGNAL PROCESSOR ARCHITECTURE STUDY - ADDED TASK
- FAULT-TOLERANT DATA SYSTEM
- SIGNAL PROCESSING BRASS BOARD
- VHSIC
- GaAs PROCESSOR
- FAULT-TOLERANT COMPONENTS
- GENERAL PROCESSING UNIT CHIP SET
- INTEGRATED SENSOR/PROCESSOR
- SPACE QUALIFIED MICROS
- MODULAR GENERAL PROCESSING SYSTEM TERMINAL

Figure 7

PRIORITIZATION OF MASS STORAGE TASKS

The bubble memory system has top priority in the mass storage area (fig. 8). Magnetic tape development and certification was an added task but was given a lower priority at this point in time because the other systems provide the best solution for the space station.

- BUBBLE MEMORY SYSTEM
- OPTICAL DISC RECORDER
- BUBBLE MEMORY DEVICES
- MAGNETIC TAPE CERTIFICATION/DEVELOPMENT - ADDED TASK

Figure 8

NETWORK CURRENT TECHNOLOGY

The network provides the capability to tie all of the computers together on the space station to solve not only the core problem but also the experiment problem. Current network technology is shown in figure 9. The structure of these data bases to allow redundancy and noninterferences is a problem. There are several DOD and DOD-industry efforts that are driving the technology to develop the techniques to connect these together as well as the type of protocol needed to determine which system is operational and which is not. There is work in the fiber optic data bus area to construct and demonstrate the implementation, but a good architecture is needed to tie them together before implementation.

The difference mediums of a twisted pair or a coaxial cable are well developed. Optical capability is just developing in the fiber optic area.

The components standard on many DOD programs are at 1 megabit. There are 50-megabit coax systems available commercially, but these are not flight qualified. There are also some commercial optical point-to-point components with a capability extending to 500 megabits per second, but they will not be compatible with every processor.

The network operating system to allow this architecture appears to work but some standard development is required. DOD and industry have some standards, but it is an area, in terms of the architecture of the space station, which needs work.

- STRUCTURE
 - MAJOR DOD/COMMERCIAL EFFORTS DRIVING TECHNOLOGY (BUS, STAR, RING) AND PROTOCOLS (TOKENS, RING, TOKEN BUS) (LOW SIGNAL INTERFERENCE/VERY LOW SIGNAL INTERFERENCE IMPLEMENTATION)
- MEDIUM
 - PAIR AND COAX WELL-DEVELOPED
 - OPTICAL, BROADBAND (DIGITAL) DEVELOPING
- COMPONENTS
 - 1 MBPS (PAIR) QUALIFIED
 - 50 MBPS (COAX) COMMERCIAL
 - 500 MBPS (OPTICAL POINT-TO-POINT) COMMERCIAL (LARGE)
- NETWORK OPERATING SYSTEM
 - STANDARDS DEVELOPING FOR COMMERCIAL/DOD

Figure 9

NETWORK TECHNOLOGY PROJECTIONS FOR 1987

Technology in 1987 will eliminate the problem of achieving high rates with fiber optic types of network (fig. 10). With very large scale integration, the capability of tying several nodes together will exist. With all the hardware shrinking in size, this integration is becoming more of a reality.

The standardization of protocols that interface with the networks should be laid out by 1987. Fiber optics will be the primary medium to satisfy the requirements on the space station. Simulation will take a look at all the network nodes and simulate them to produce a comparative set of quantitative numbers to determine which is best or provide reasons for selecting one over the other and to have a realistic traffic model of what the data bus will look like. Network operating systems are developed to DOD and commercial standards but are not set to handle the data rates for the space station. Sufficient funding is needed to allow this to occur for the space station environment. The DOD fault-tolerant, self-correcting operating system may be applicable to the space station.

- STRUCTURE
 - HIGHER RATES
 - SHRINKING NODES (VLSI)
 - STANDARDIZED ACCESS PROTOCOLS
- MEDIUM
 - OPTICAL, BROADBAND DEVELOPED
- COMPONENTS
 - 1 GBPS (OPTICAL POINT-TO-POINT)
 - COUPLERS
 - VLSI AT HIGHER RATES
- SIMULATION
 - COMPARATIVE SIMULATION
 - REALISTIC TRAFFIC MODEL
- NETWORK OPERATING SYSTEM
 - DEVELOPED COMMERCIAL/DOD STANDARDS
 - DOD DEVELOPED FAULT-TOLERANT/SELF-CORRECTING OPERATING SYSTEM

Figure 10

NETWORK TALL POLES

Network tall poles in the simulation area (fig. 11) involve early development of models to determine what the traffic will be like on the data bus and use the results from the model to derive technology choices and set up the architectures. To qualify the networks, thermal problems associated with fiber optics must be overcome. High-performance optical components need to be developed and reliability designs established.

- SIMULATION
 - EARLY DEVELOPMENT OF MODELS AND SPACE STATION TRAFFIC
 - RESULTS DRIVE OTHER TECHNOLOGY CHOICES

- QUALIFICATION
 - HIGH-PERFORMANCE WIRE INTERFACES
 - OPTICAL COMPONENTS

- HIGH-PERFORMANCE OPTICAL COMPONENTS
 - DEVELOPMENT
 - RELIABILITY

Figure 11

PRIORITIZATION OF NETWORK TASKS

The prioritization of the network tasks is given in figure 12. Development of information networks architectures and fiber optic compact technologies is at the top of the list. Fiber optic reliability is an added task.

INFORMATION NETWORK ARCHITECTURES
FIBER OPTIC COMPONENT TECHNOLOGY DEVELOPMENT AND DEMONSTRATION FOR SPACE STATION
FLIGHT DEMONSTRATION - OPTICAL BUS/NETWORK
FUTURE DATA SYSTEM CONCEPTS
OPTICAL BUS COMPONENTS
ONBOARD DATA PROCESSING AND HANDLING/FIBER OPTIC DATA BUS
ENVIRONMENTAL EFFECTS ON FIBER OPTICS
OPTICAL SWITCHES
FIBER OPTIC RELIABILITY ADDED TASKS
GATEWAYS

Figure 12

SYSTEMS/SOFTWARE CURRENT TECHNOLOGY

The development of requirements for software is extremely labor intensive at this time (fig. 13). The result is that a lot of the wrong codes are being implemented. Considerable breakage in the code occurs because the requirements themselves are labor intensive (skilled communicators are needed to make sure that the right problem is being solved). Software development facilities are specialized. On the Shuttle, a different software development facility was used for the main engines than for the on-board system. Facilities tend to be set up for developing software tailored to the hardware. Currently, moving software from one computer to another generates problems and ends up as a high cost factor. Hopefully, the state of the art will get away from this practice and emphasize development of software support systems that are not as specialized.

Since all data systems seem to be independent of one another, a linkage needs to be developed. Software systems are real time driven at the present. Currently, the software is optimized for a specific computer, but if the problem gets outside the limits of the computer, then the cost of trying to optimize the code to fit the system increases. Networks and distribution are limited and tailored to a specially designed computer, so that standardization is separate. The capabilities of the processors are limited by the resources of memory and throughput capability of the machine.

- SOFTWARE DEVELOPMENT
 - DEVELOPMENT OF REQUIREMENTS AND SOFTWARE IS LABOR INTENSIVE EFFORT
 - SPECIALIZED SOFTWARE DEVELOPMENT FACILITIES
 - NO STANDARD LANGUAGES OR PROTOCOLS
 - HIGH COST
- SOFTWARE SYSTEMS
 - MULTIPLE INDEPENDENT DATA SYSTEMS
 - REAL-TIME DATA DRIVEN
 - LIMITED NETWORKS AND DISTRIBUTION
 - CAPABILITIES/PROCESSES LIMITED BY ONBOARD RESOURCES

Figure 13

1987 SYSTEMS/SOFTWARE TECHNOLOGY PROJECTIONS

By 1987, automation will reduce cost of requirements documentation and maintenance (fig. 14). Several systems exist today which set up a standard way of defining what requirements are for software. Once these types of systems are used to define requirements, any change is easier to implement in terms of the requirements documentation, as well as in the final code. Automation (automated tools) will also reduce development testing. Standardization in languages, interfaces and protocols, and a development environment will increase.

An extensive improvement in on-board resources will occur by 1987, with the capability of virtual memories available. A distributive architecture allows the addition of another processor instead of shoehorning into a single processor. Software systems will be driven by real-time bulk data processing.

- SOFTWARE DEVELOPMENT
 - AUTOMATION WILL REDUCE COST OF
 - REQUIREMENTS DOCUMENTATION AND MAINTENANCE
 - SOFTWARE DEVELOPMENT TESTING AND MAINTENANCE
 - STANDARDIZATION IN
 - LANGUAGES
 - INTERFACES/PROTOCOLS
 - DEVELOPMENT ENVIRONMENT
- SOFTWARE SYSTEMS
 - EXTENSIVE IMPROVEMENT IN ONBOARD RESOURCES
 - DRIVEN BY REAL TIME AND BULK DATA PROCESSING
 - DISTRIBUTED SYSTEMS
 - EXTENSIVE NETWORKS
 - APPLICABLE DATA BASE MANAGEMENT SYSTEMS

Figure 14

SYSTEMS/SOFTWARE TALL POLES

The principal tall pole is data system architecture definition, which is set up so that the architecture can evolve over the entire life of the space station and accommodate new technologies of adding processors (fig. 15). The cost of on-board software development and testing involves the development of more test tools. The absence of a carryover standardization from program to program exists now. Restrictions in on-board functions are due to resources and include data base management (currently unable to handle distributed data base systems), user friendly capability, and networks. Data base management systems are, in terms of technology, not too bad for the commercial world but have not been adequately applied to the engineering environment. User-friendly capability applies to the data base also.

- DATA SYSTEM ARCHITECTURE DEFINITION FOR
SYSTEM EVOLUTION/GRACEFUL GROWTH
- COST OF ONBOARD SOFTWARE DEVELOPMENT AND TESTING
- ABSENCE OF CARRYOVER/STANDARDIZATION FROM PROGRAM TO PROGRAM
- RESTRICTIONS IN ONBOARD FUNCTION DUE TO RESOURCES
DATA BASE MANAGEMENT
USER FRIENDLY
NETWORKS

Figure 15

PRIORITIZATION OF TASKS

In prioritizing the tasks shown in figure 16, the data base architecture study will be done in the near future and will provide solutions to many of the problems being worked. A software acquisition management plan is being formalized. With all these distributed processors, a real problem exists in managing the development of the software.

Probably the most important added task is the development of artificial intelligence/expert systems. At least three other technologies have listed the development of artificial intelligence as a requirement.

1. SOFTWARE ACQUISITION MANAGEMENT PLAN
2. SPACE STATION FLIGHT DATA SYSTEM ARCHITECTURAL STUDY
3. *SPACE STATION USER DATA SYSTEM INTERFACE
4. *AUTOMATION OF SOFTWARE DEVELOPMENT PROCESS
5. *AUTOMATION OF SOFTWARE TESTING
6. DISTRIBUTED DATA BASE MANAGEMENT
7. ADA (AUTOMATED DATA ACQUISITION) EVALUATION AND TRANSITION AND PLANNING
8. NETWORK OPERATING SYSTEM SOFTWARE
9. FAULT TOLERANT COMPUTER SYSTEM VALIDATION METHODOLOGY FOR ONBOARD DATA MANAGEMENT SYSTEM
10. *SYSTEM INTEGRATION
11. *ARTIFICIAL INTELLIGENCE/EXPERT SYSTEMS
12. SPACE STATION DATA NETWORK CONCEPT
13. SPACE STATION STANDARD INTERFACE PROTOCOLS
14. SPACE STATION DATA NETWORK SYSTEMS
15. *INTEGRATED SOFTWARE DEVELOPMENT FACILITY
16. *LANGUAGE TRADE STUDIES

* TASK ADDED

Figure 16

RECOMMENDATIONS

The synopsis of the recommendations listed in figure 17 shows standardization for hardware and software for the core system of the space station as the first priority. The structure and/or design (architecture) for both processors and data base system need to be narrowed. This cannot be done arbitrarily. Quantitative numbers are needed to make a rational decision. The work on analysis and simulation models related to the requirements of both the processor and the network system is more on a hardware level. However, these types of analysis models provide the same thing that the architecture does in terms of some quantifiable data which say what the allocation should be between processors, software, and networks. The technology is probably here to enable the distributed data base management but it needs to be obtained from the commercial community and architected for a space station environment.

- STANDARDIZATION FOR HARDWARE/SOFTWARE

- STRUCTURE/DESIGN CHOICES NARROWED (NOT ARBITRARILY)

- ANALYSIS SIMULATION MODELS FOR PROCESSOR/SOFTWARE/NETWORKS
ALLOCATION

- ENABLE DISTRIBUTED DATA BASE MANAGEMENT

Figure 17

POWER

Robert Corbett
Lockheed Missiles and Space Company
Sunnyvale, California

Space Station Technology Workshop
Williamsburg, Virginia
March 28-31, 1983

UNDERSTANDING OF WORKSHOP CHARTER

The workshop charter established a goal of evaluating the OAST power program for the space station (fig. 1). The first point was to establish the technology and state of the art of power components to support the space station. There have been some very fine subsystem level studies in recent years which have also been effective in comparing various component options to perform the power system functions of power generation, energy storage, and power control and distribution.

The panel set out to identify key issues as they relate to the technology status and define the direction of technology programs to resolve those issues. The level of technology readiness for initial and evolutionary space station transitioning and a prioritized list of tasks to support the program were defined. The panel also proposed a mechanism for NASA-industry coordinated planning.

ESTABLISH TECHNOLOGY STATUS & STATE OF THE ART.

IDENTIFY KEY ISSUES ASSOCIATED WITH THE SPACE STATION AS THEY RELATE TO TECHNOLOGY STATUS.

DEFINE THE DIRECTION OF TECHNOLOGY PROGRAMS TO RESOLVE THESE ISSUES AND MEET THE SPACE STATION NEEDS.

IDENTIFY LEVEL OF TECHNOLOGY READINESS FOR INITIAL AND EVOLUTIONARY SPACE STATION TRANSITIONING.

PREPARE A PRIORITIZED LIST OF TASKS TO SUPPORT THE TECHNOLOGY PROGRAM.
IDENTIFY CRITERIA.

PROPOSE A MECHANISM FOR NASA-INDUSTRY COORDINATED PLANNING.

Figure 1

POWER PROGRAM OVERVIEW

It is important to realize that the space station requires an increase in power or energy of at least several orders of magnitude compared to previous space missions. With the requirement up in the range of 10 kilowatt hours, this obviously requires the development of new technology. Although the power area is very well integrated in the spacecraft itself, it represents a diverse set of components necessary for energy conversion, electronics, and energy distribution. Considerable work is ongoing at NASA Lewis in the power devices development area, including transformers, large area solid-state chips, transistors, and fast recovery diodes. This work is oriented toward eventual application to both AC and DC power conversion approaches. In the energy storage area, there are many options available to fit into the space station representing various degrees of risk and leverage combination, such as the near-term integral-pressure-vessel nickel-hydrogen battery, an advanced Ni-H₂ battery concept, and the regenerative hydrogen-oxygen system utilizing essentially the Shuttle orbiter type of fuel cell. Also, there is the solid polymer electrolysis and fuel cell unit (acid fuel cell) which has the advantage of integrating very well with the life support and reaction control systems.

Most of the current power work relates to solar power and photovoltaics, but there is also work on nuclear power which ultimately is applicable to the space station but is not clearly applicable at the present because of the absence of clear space station time lines. The nuclear power system has certain interesting advantages, notably reduced drag.

A solar array flight experiment, based on the original solar electric propulsion (SEP) array technology, is scheduled to fly on an STS mission next year. It is essentially a dynamic test bed for the flexible solar array system. Other advanced solar array concepts with perhaps lower costs but higher risks are being studied. These include various concentrator approaches, such as cassegranian (high concentration ratio) and flat plate (low concentration ratio).

POWER PANEL RECOMMENDATIONS—ISSUES

Since solar arrays are the main power generation being considered at present for the prime power of the space station, it is important that the environmental interaction and potential impacts on the solar array design and, in fact, on the power system design are understood (fig. 2). High power mandates high voltage. A number of Skylab spacecraft could be strung together, but in reality a very ineffective and expensive system would result without making the jump to higher voltage power conversion, whether AC or DC. Also, there is the question of how high-voltage solar arrays would react in the near-Earth-orbit high-density plasma field. It is not clear that the models will produce the practical phenomenology of what happens without significantly more experimental data, preferably from a flight experiment with a full-scale array. The solar array performance models are well worked out and thorough, but are limited in the area of cost modeling. The cost model is not standardized and the cell costs are not well established. Since costs, both initial and life cycle, are such important factors to the space station, cost modeling becomes a key issue.

There are many options in the energy storage area that are difficult to sort out because of the complex, inter-subsystem performance effects, notably with the hydrogen-oxygen system. The nickel-cadmium battery has been the baseline for about 25 years. No other battery of a secondary type has seen significant use, and none has the data base to give confidence in the reliability calculations as the NiCd does. Establishing a Ni-H₂ data base is an extremely important issue.

The issue of AC versus DC is less critical. Good designs have been identified in study proposals, but the preferred system has not been decided upon.

In the power electronics area, the issue of switchgears, both for AC and DC, is key. Higher power means larger switchgears. Volume and mass will be key items in the installed areas of the space station.

PRIME POWER:	PLASMA EFFECTS IMPACT ON SOLAR ARRAY CONFIGURATION AND EPS CONFIGURATION. INADEQUACY OF SOLAR ARRAY LIFECYCLE COST MODELS.
ENERGY STORAGE:	NICKEL-HYDROGEN DATA BASE AND NEGLIGIBLE ABSENCE OF PLANS FOR SAME. LACK OF AN ADEQUATE ENERGY STORAGE TRADE STUDY.
SYSTEM:	LACK OF A DEFINITIVE TOPOLOGY AND REGULATION SCHEME TRADE; E.G., AC VS DC, VOLTAGE LEVEL, REGULATION.
POWER ELECTRONICS:	NEED FOR DIRECTION AND REQUIREMENTS FOR SWITCHGEAR PROGRAM. ABSENCE OF POWER CONVERSION DEVELOPMENT ACTIVITY.

Figure 2

POWER PANEL RECOMMENDATIONS--DIRECTIONS

Funds for technology are limited, but an aggressive environmental and materials compatibility program for solar power needs to be pursued, with emphasis on flight experiments and array-specific modeling (fig. 3). (The model can handle the planar array, but not the concentrator array.) Periodic system studies, or subsystem level studies, will aid in controlling component R&D work, auditing R&D work, and directing future component activity. Since there are four or five kinds of energy storage, the question of eliminating one or more for the improvement of perhaps the best candidate arises. When this inter-subsystem or component trade is conducted, some indicators of relative performance merit, mass, volume, heat dissipation, and cost can be obtained. However, without space station requirement sets or configuration sensitivities, the competency to make that selection does not exist. For example, for the solar array, different area performance figures have been projected for the various array options. Drag, especially in the Shuttle parking orbit, is a critical issue, but the relative importance of drag, as compared to mass, volume, or initial cost, is unknown.

PURSUE AN AGGRESSIVE, STEPPED-UP ENVIRONMENTAL AND MATERIALS COMPATIBILITY PROGRAM
EMPHASIZING FLIGHT EXPERIMENT AND ARRAY-SPECIFIC MODELING.

CONTINUE TO FUND OCCASIONAL, REGULAR SUBSYSTEM STUDIES TO
AUDIT R&D EFFORT
DEFINE SYSTEM IMPACT OF COMPONENT IMPROVEMENTS
DIRECT FUTURE COMPONENT WORK

MAINTAIN ALL PRESENT ELEMENTS OF THE OAST POWER PROGRAM IN ANTICIPATION OF SPACE
STATION REQUIREMENTS/CONFIGURATION STUDIES.

Figure 3

TECHNOLOGY READINESS DETERMINATION

Current, traditional guidelines should be followed in technology transitioning (identifying the level of technology at which transition should occur). Once a proof of concept, a reasonably adequate data base, is obtained and an application exists, the program should be transitioned to advanced development, a development within the context of the specific program (fig. 4). If transitioning is not done, the funds for detailed hardware will come from scarce technology resources and future technology suffers. It is important that when a product goes on-line, the same technology funds should be used for the increased performance, which produces improved performance on the evolutionary station.

A flight testing approach (obtaining the data base in flight) would reduce costly data base and demonstration efforts. With regular servicing, it is not necessary to know that a battery will last 2, 3, 4, or 5 years. It may only last for 1 year. The calculated risk with early servicing will save development and data base costs.

- (A) AT THE MOST: FOLLOW THE PRESENT GUIDELINE:
TRANSITION TECHNOLOGY AT COMPLETION PROOF OF CONCEPT TO
ADVANCED DEVELOPMENT FUNDING.
THIS FOCUSES SCARCE TECHNOLOGY FUNDS TO HIGH PERFORMANCE
EVOLUTIONARY APPROACHES.

- (B) CONSIDER A FIELD TESTING APPROACH TO REDUCE COSTLY DATA BASE AND
DEMONSTRATION EFFORTS.

Figure 4

PRIORITIZED LIST

Instead of a prioritized list, the power panel prefers many technology options that can be used when the program timeline is understood (fig. 5). Currently, there are some big uncertainties about space stations. One is configuration, and the other is exactly when the space station will occur. These are working ground rules, but to make a critical component decision at this point would be to establish a development risk for one component or, at the other extreme, to fly a very sub-optional component for the timeline of the specific station. Enough information is not available to rank the technology program priorities. The sensitivity factors are needed to make that selection process. The technology program can be focused, but that essentially has to wait until after the requirements, definition, and program timeline definition processes. The panel established a top-level prioritization based on configuration sensitivity.

INFORMATION IS NOT AVAILABLE TO RANK ORDER ENTIRE TECHNOLOGY PROGRAM.

ALTERNATE CONCEPT SELECTION OR PRIORITIZATION REQUIRES SYSTEM SENSITIVITY FACTORS BASED ON SS SYSTEM CONFIGURATION.

TECHNOLOGY PROGRAM CAN AND SHOULD BE FOCUSED BUT THIS REQUIRES:

REQUIREMENTS FLOWDOWN AND REFERENCE CONFIGURATION.

ADOPTION OF A SS DEVELOPMENT TIMELINE.

WE CAN ESTABLISH A TOP-LEVEL PRIORITIZATION BASED ON CONFIGURATION SENSITIVITY.

Figure 5

TOP-LEVEL PRIORITY LIST

The top-level priority list (fig. 6) does not reflect accurately what the real problems are, which of the areas require more attention, and which of the areas do not include performance as a concern. The important thing to realize is that there are not satisfactory data at the present to give the confidence to fly what is called a high voltage system. Such a system, if nominally a 140-volt system, would have a peak solar array voltage approaching 500 volts. Still higher nominal bus voltages would exceed this peak level. A conventional system (28 volt) is one which has a solar array (S/A) which typically runs from perhaps 40 volts at nominal operation to as high as 70 volts during exit from the eclipse or under some kind of shaded condition. Skylab was a little bit higher than standard, about a 40- to 50-watt nominal power system supply voltage with an array which operated at about 50 or 60 volts at operating temperature and could go as high as 100 or 120 volts. Not having the information on the solar array to give confidence to fly a higher voltage array will mean resorting to flight qualification data or flying an array with the same series complement of cells and up-converting (using a transformer-type converter) to a more effective voltage.

The present photovoltaics and energy storage program should be maintained. There is a ranking relationship here in the sense that the energy storage and power generation are a bit more important than the power electronics because the configuration of the space station is more sensitive to that technology than it is to the power electronics. The power electronics is also a smaller fraction of the total system and is at a better state of development.

The environmental interaction is an enabling technology and the other issues listed in figure 6 are enhancing technologies because they are essentially performance related.

ENVIRONMENTAL INTERACTION/ MATERIALS COMPATIBILITY	S/A, POWER CONTROL DESIGN IMPACT ----- MAY DRIVE 50 - 60V. S/A.
MAINTAIN PRESENT: SOLAR POWER PROGRAM ENERGY STORAGE PROGRAM	CAN'T SELECT WITHOUT SPACE STATION SENSITIVITIES AND TIMELINE. VARIOUS RISK/ LEVERAGE LEVEL.
MAINTAIN POWER DEVICES PROGRAM AUGMENT WITH: AC AND DC SWITCHGEAR. POWER CONTROL CONVER- SION.	IMPORTANT AND SUCCESSFUL REQUIRES CONFIGURATION STUDIES TO RESOLVE ULTIMATE SELECTION.

Figure 6

MECHANISM FOR NASA-INDUSTRY COORDINATION

The issue of how to continue this panel process to feed information directly from the functional organizations to the Space Station Technology Steering Committee was addressed (fig. 7). Existing committees have a full docket of commitments, so they would not be able to address this process with a great deal of depth and breadth. They would not necessarily have the right people, the right currency, or the right turnover in the sense of representing the working engineer who is currently doing space station work. A new committee, similar to this panel but smaller, totally responsive to space station needs and reporting to the Space Station Technology Steering Committee, would do the job very well.

OPTIONS: NEW GROUP -- SIMILAR TO THIS PANEL BUT SMALLER
 AIAA SPACE POWER COMMITTEE
 IEEE ELECTRICAL POWER/ENERGY SYSTEMS PANEL
 SPACE SYSTEMS TECHNICAL ACTIVITIES COMMITTEE POWER SUBCOMMITTEE

EVALUATION: EXISTING GROUPS
 HAVE FULL CHARTER/COMMITMENTS
 ARE HIGHER UP ORGANIZATIONALLY
 DON'T HAVE TURNOVER WHICH IS NEEDED TO
 MAINTAIN BALANCE.

RESOLUTION: NEW COMMITTEE, TOTALLY RESPONSIVE TO SS NEEDS REPORTING
 TO SSTSC.

Figure 7



THERMAL CONTROL

Bob Haslett
Grumman Aerospace Corporation
Bethpage, New York

Space Station Technology Workshop
Williamsburg, Virginia
March 28-31, 1983

TECHNOLOGY APPLICATION TO SPACE STATION ACTIVE THERMAL CONTROL

There are basically three key ingredients to the thermal control system for any large space platform or space station. These are heat rejection (from a centralized radiator or from body-mounted radiators), heat acquisition (from payloads), and heat transport (via a transport loop to the radiator). The system shown in figure 1 is similar to the Shuttle system. The Shuttle has fluid loop radiators in the doors, cold plates, and a pumped Freon liquid loop which takes heat to the radiator.

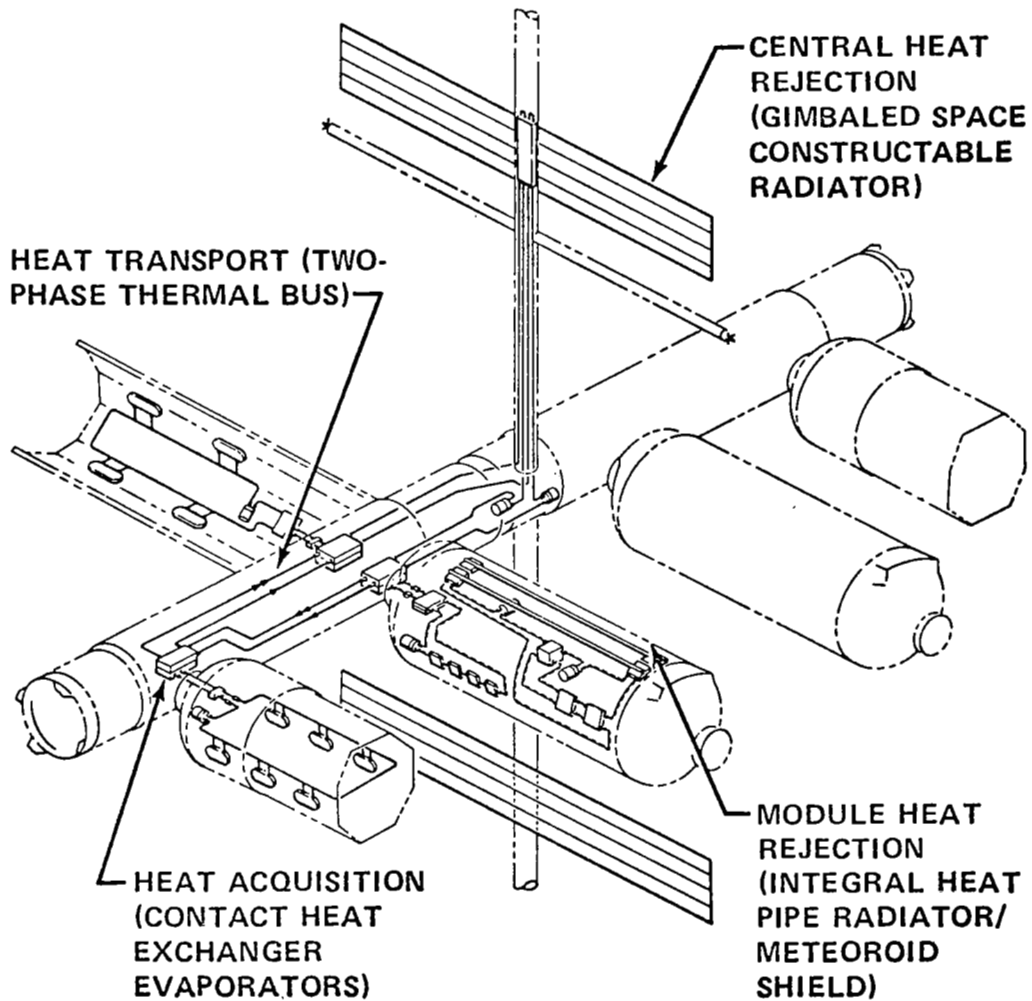

Figure 1

THERMAL ISSUES/PROBLEMS

The first objective in considering thermal control is to determine if the space station requirements present new thermal issues and/or problems which would indicate that the current approach is not the one to continue pursuing (fig. 2). The space station will be an indefinite in-orbit type system, as opposed to the several-week sortie of the Shuttle. This makes the meteoroid hazard to the radiators and the degradation of thermal coatings much more important issues, and points in the direction of repair procedures or modular construction allowing replacement. The station will try to accommodate many more users, so users would benefit greatly if there were a standard thermal condition or several standard conditions which could be specified to facilitate design of individual equipment. Some users will require cold plates, others will want fluid connections to a thermal system. Therefore, diverse interfaces are needed. The other key issues are much more efficient operation, growth, and maintenance. The space station cannot tolerate the large amount of crew or ground involvement presently required. This suggests automated control of the thermal system. Maintenance is necessary to achieve open-ended mission life, and this indicates the need for modular design and fault detection and isolation.

- O LONG LIFE RADIATOR
 - MICROMETEORIDS AND DEBRIS
 - COATINGS

- O USER FRIENDLY HEAT TRANSPORT LOOP
 - KNOWN THERMAL CONDITIONS
 - DIVERSE INTERFACE OPTIONS

- O EFFICIENT OPERATION/GROWTH/MAINTENANCE
 - AUTOMATED CONTROL
 - MODULAR
 - FAULT DETECTION AND ISOLATION

Figure 2

NASA ACTIONS TO DATE

This workshop is by no means the first attempt to assess these issues (fig. 3). In fact, NASA has had a Thermal Working Panel for a number of years. This panel recognized the benefits of incorporating new technology into the space station. Specific critical long lead items were identified, system trade studies were initiated to identify approaches to be taken, and early prototype hardware contracts were let. Early investment in inherently reliable/maintainable systems was identified as the key to lower life cycle costs for the space station. Plans to pursue these new technologies came from these government working groups.

- 0 RECOGNIZED BENEFITS OF NEW TECHNOLOGY

- 0 INITIATED NUMBER OF MODERATE EFFORTS ON CRITICAL LONG LEAD TECHNOLOGIES

- 0 IDENTIFIED RELIABILITY/MAINTAINABILITY AS KEY TO LOWER LIFE CYCLE COSTS

- 0 DEFINED A PLAN TO REALIZE THESE BENEFITS ON SPACE STATION

Figure 3

TECHNICAL APPROACH

The technical approach in the heat rejection area (fig. 4) is to construct the radiator from individual elements so that it can be built on-orbit, is very insensitive to meteoroid and debris hazards, and is repairable. This clearly points in the direction of changing from the Shuttle's pumped liquid-loop radiators, where a single puncture will drain out, in the Shuttle's case, half the system (one of the sides of the system). For indefinite life, multiple elements are required in the radiator system, so that a failure in any one is not catastrophic. There are three approaches to the coating problem: rotate the radiators to reduce the time the radiator looks at the Sun and hence the sensitivity to coating degradation, maintain the coating, or develop a more stable coating. All three approaches require advances in the current technology.

The heat transport loop issue points toward new technology, away from the Shuttle's pumped liquid loop to a two-phase loop which would operate at a constant temperature (all users would see the same conditions). Evaporative cold plates can accommodate approximately a factor of 10 higher heat flux than the current Shuttle cold plate, and users are not sensitive to the placement of the equipment on the loop since the loop temperature does not go up as the flow goes through each piece of equipment. The key integration issues are to satisfy the diverse users with various interfaces and to provide the technology flexibility needed to support an evolving station architecture.

HEAT REJECTION

- 0 HIGH CAPACITY HEAT PIPE RADIATOR
 - INDEPENDENT ELEMENTS (EACH 1-2 KW)
 - ON-ORBIT ASSEMBLY/REPLACEMENT (MIN ASTRONAUT INVOLVEMENT)
 - ROTATABLE RADIATOR AND/OR MAINTAINABLE COATING

HEAT TRANSPORT LOOP

- 0 TWO PHASE (EVAPORATIVE AND CONDENSING COLD PLATES)
 - CONSTANT TEMPERATURE LOOP
 - VERY HIGH HEAT FLUX CAPABILITY
 - COOLANT TEMP NOT DEPENDENT ON EQUIPMENT PLACEMENT OR HEAT LOAD

SYSTEM INTEGRATION

- 0 DIVERSE USERS
 - VARIOUS INTERFACES; COLD PLATE, FLUID, DRY CONTACT, DISCONNECTS
- 0 STATION ARCHITECTURE
 - DISTRIBUTED STATIONS, OTV'S, BACKPACK, SATELLITE SERVICING

Figure 4

CONSTRUCTABLE RADIATOR

The basic principle of the space constructable radiator, with individual heat pipe elements, is illustrated in figure 5. Each element is designed to have the capacity to reject 1 to 2 kilowatts and as many can be put together in orbit as are required for the station. Elements that are damaged can be replaced and the station can grow over time. The radiator weighs approximately 10 times more than the balance of the thermal control system and is the largest, most exposed, and most vulnerable area. For these reasons, NASA initiated development of this new radiator concept over 3 years ago in anticipation of space station/space platform needs.

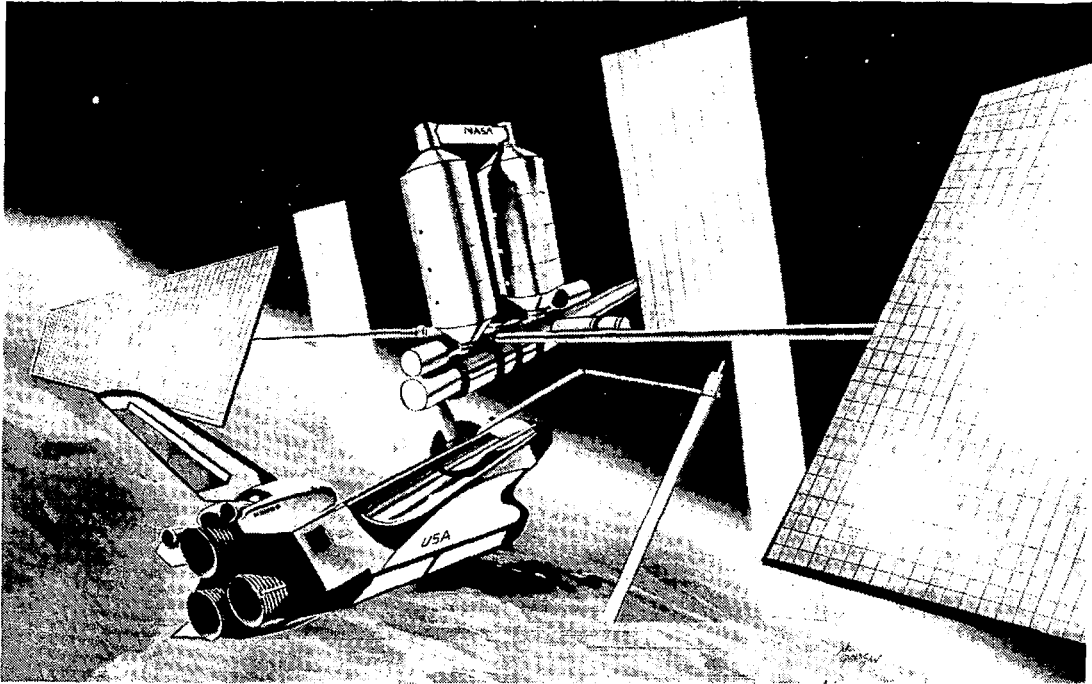

Figure 5

PROTOTYPE RADIATOR HEAT PIPE

Because NASA has identified heat pipe thermal radiators as the pacing technology to achieve high reliability and growth capability, technology efforts have been initiated to develop a prototype high-performance heat pipe. A 50-foot heat pipe undergoing testing is shown in figure 6. It has a six-leg evaporator section for compact attachment to the heat transport loop.

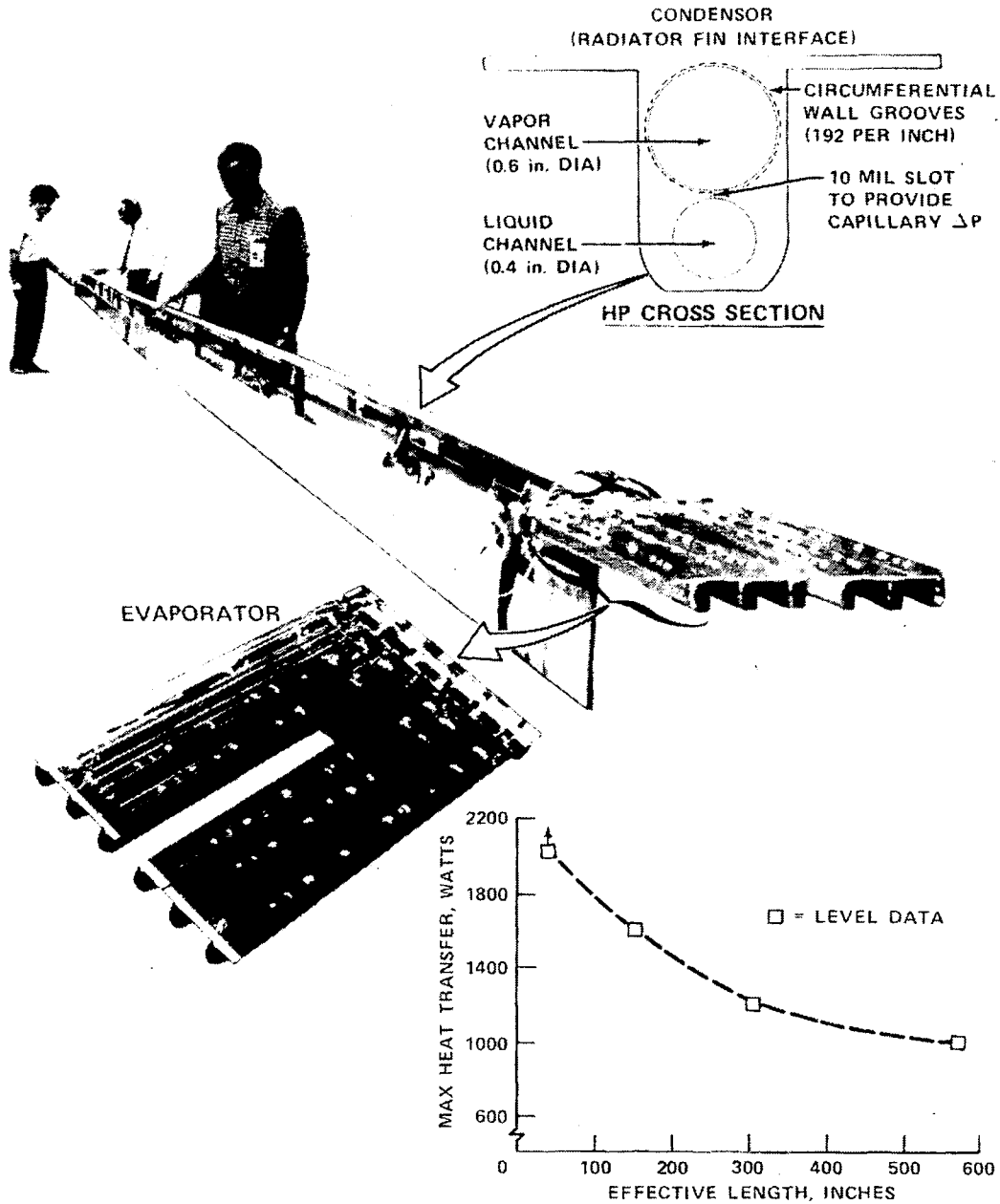

Figure 6

TWO-PHASE THERMAL BUS CONCEPT SCHEMATIC

The two-phase heat transport loop concept is illustrated in figure 7. In this technology, there are a number of alternate paths being pursued. This shows a parallel flow arrangement in which liquid is taken to all of the cold plates, heat is added, the fluid evaporates, and the vapor is returned to a condenser coupled to the radiator.

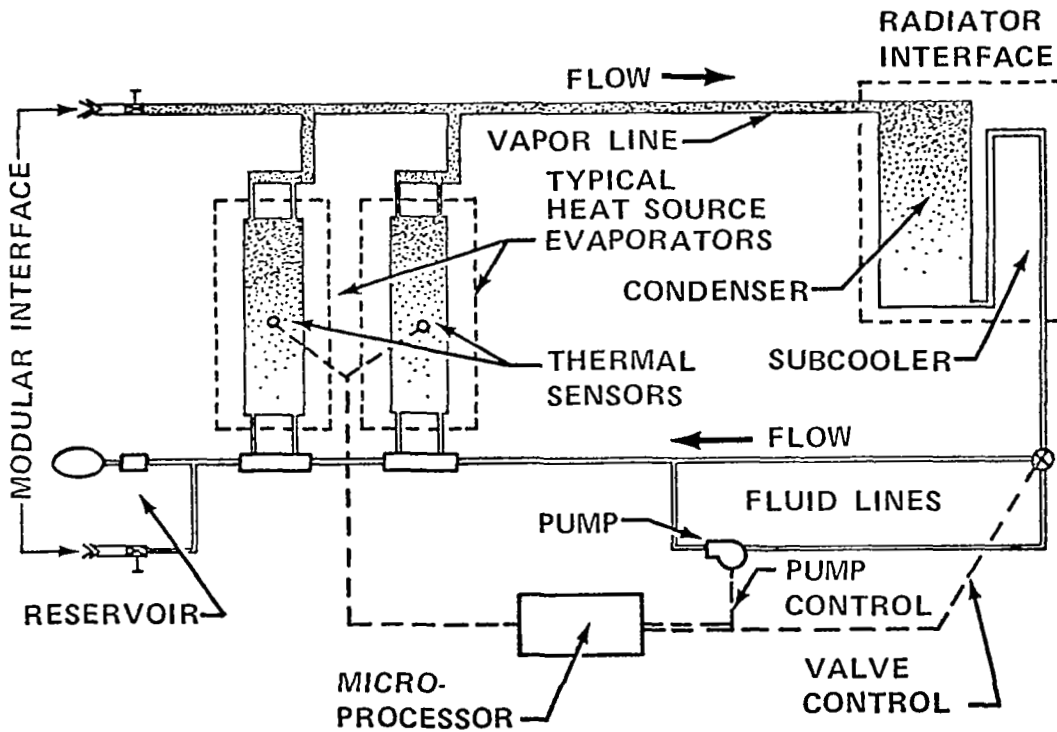

Figure 7

NASA THERMAL GOALS AND OBJECTIVES

NASA has already done comprehensive planning on the thermal goals and objectives in order of priority, as shown in figure 8. There are three goals: long-life heat rejection, versatile thermal acquisition, and transport and integrated thermal utility. The objectives are listed under each goal in priority order. This listing was used by the panel to evaluate the NASA program.

GOAL - 1: LONG LIFE HEAT REJECTION

- OBJECTIVE 1 - HIGH CAPACITY HEAT PIPE RADIATOR
- 2 - DEPLOYABLE/CONSTRUCTABLE RADIATOR SYSTEM (FLIGHT EXPERIMENT)
- 3 - ENVIRONMENT SENSING RADIATOR SYSTEM
- 4 - MAINTAINABLE/REPLACEABLE FLUID RADIATOR
- 5 - THERMAL COATING MAINTENANCE/REFURBISHMENT

GOAL - 2: VERSATILE THERMAL ACQUISITION AND TRANSPORT

- OBJECTIVE 1 - CENTRALIZED THERMAL BUS TRANSPORT
- 2 - HIGH DENSITY HEAT ACQUISITION
- 3 - HEAT TRANSFER ACROSS STRUCTURAL BOUNDARIES
- 4 - LONG LIFE FLUID SYSTEMS

GOAL - 3: INTEGRATED THERMAL UTILITY

- OBJECTIVE 1 - THERMAL STORAGE/LOAD LEVELING/REFRIGERATION
- 2 - UTILITY SYSTEM INTEGRATION TEST BED
- 3 - INST. MODULE TEST BED
- 4 - AUTOMATIC SYSTEM CONTROL/MONITORING/FAULT ISOLATION
- 5 - THERMAL COMPUTER MODEL IMPROVEMENT
- 6 - GROUND TEST CAPABILITY
- 7 - INFLIGHT HANDLING AND MAINTENANCE

Figure 8

INDUSTRY EVALUATION

The criteria used in the technical evaluation are listed in figure 9. The bottom line in appraising the plan was whether the technology level being sought is affordable, too advanced, too high risk, or requires too much development.

- o CRITERIA -
 - PROGRAMMATIC
 - DOES IT MEET UNIQUE SPACE STATION REQUIREMENTS?
 - TECHNICAL
 - WILL IT WORK?
 - SCHEDULE
 - WILL IT BE ON TIME?
 - RELIABILITY/SAFETY
 - IS IT INHERENTLY RELIABLE?
 - COST
 - WILL IT BE AFFORDABLE?

Figure 9

WHAT ARE THE GOOD POINTS?

The critique of the plan indicated a number of good points, particularly the overall goals and objectives (fig. 10). The development of high capacity heat pipe radiators, which is a new technology, was specifically good. To backtrack, when the effort was initiated 3 years ago, heat pipe performance was on the order of 5,000 to 10,000 watt-inches for extruded type heat pipes that could be mass produced for a large station. The goal was 1 million watt-inches, which is two orders of magnitude better. These are the kinds of improvements that are being sought in the thermal program. New technology is called for in this instance. The current Shuttle technology is not appropriate for the space station. It would be an extremely brute force way to satisfy the space station needs. The payoffs in the new technology are good. The radiator is a tremendous improvement in reliability and maintainability for a relatively modest front-end cost. To satisfy users, which is the objective of the space station, the two-phase system is far superior to a pumped fluid-loop system. The plan also recognized the importance of providing the analytical tools, ground test beds, and flight tests to develop this new technology.

- O GOALS AND OBJECTIVES ARE RIGHT ON
 - IMPORTANT ISSUES
 - PRIORITY
- O PLAN PROVIDES FOR HIGH LEVERAGE NEW TECHNOLOGY DEVELOPMENT

<u>GOAL</u>	<u>PAYOFF</u>
- LONG LIFE HEAT REJECTION.	HIGH BENEFIT FOR COST
- VERSATILE THERMAL ACQUISITION . . .	MODULARITY, GROWTH, FLEXIBILITY AND TRANSPORT
- INTEGRATED THERMAL UTILITY.	AUTOMATION, ECONOMY
- O PLAN RECOGNIZES NEED FOR ANALYTICAL TOOLS
- O PLAN INTEGRATES NEW TECHNOLOGY-TEST BED
- O PLAN PROVIDES FOR FLIGHT TEST OF CRITICAL COMPONENTS

Figure 10

WHAT WERE THE BAD POINTS?

The few bad points presented in figure 11 are interrelated and cannot be taken out of context. The plan is underfunded in the near term. Since the system is totally new, more parallel development is needed in the early stages, when it is not possible to commit to one approach. The parallel efforts are only a small percentage of the main effort and are constrained by funding. Flight test tasks are not scheduled to support a phase C/D start in 1987. If this date were 1992 or 1993, the plan as presented would be fine. The reason for the inconsistency between need date and the plan as shown is funding. The need for early flight tests is emphasized. Since some basic mechanisms work better on the ground than in space, high capacity heat pipes and two-phase heat transport loops must be tested in the real environment.

In summary, it is a high risk program only in the context of the early need date relative to the current budget limitations. The flight test schedule does not support the need date; therefore, the cost risk is high because problems will occur downstream that will be expensive to correct. Also, the funding is limiting the parallel development, which adds a little technical risk.

- O UNDERFUNDED AND POORLY TIME PHASED

- O INSUFFICIENT PROVISION FOR PARALLEL DEVELOPMENT OF CRITICAL TECHNOLOGIES
 - HEAT REJECTION SYSTEM
 - THERMAL TRANSPORT LOOP

- O TASKS NOT SCHEDULED TO SUPPORT PHASE C/D START IN 1987

- O EARLY FLIGHT TEST OF TWO-PHASE FLUID SYSTEMS NOT INCLUDED

- O SUMMARY: HIGH RISK PROGRAM
 - SCHEDULE
 - COST
 - TECHNICAL

Figure 11

RECOMMENDED MODIFICATIONS

There is not enough emphasis on advanced heat rejection concepts (fig. 12). NASA has been looking at body mounting for some of the heat rejection systems instead of at constructable, large radiators, but this does not appear in the plan. It is likely that the early space station will have some body-mounted radiators. The habitat may have its own radiator and be the storm collar, if the main system goes out for any reason. The crew could survive in the habitat until repair or rescue. NASA is also participating in some advanced concepts (such as the droplet radiator) but this technology does not appear in the plan.

In the heat transport area, two-phase flow is a major area for additional investigation, both analytical and experimental. The proper emphasis for understanding the basics of two-phase flow is not in the current plan. Funding on the user-oriented devices should be delayed until more specific space station needs are identified.

The key area identified was the need for early flight development tests because of the new technology. Flight tests and supporting ground tests would verify computer models required for space station thermal system design optimization.

O LONG LIFE HEAT REJECTION

- ADD BODY MOUNTED HEAT REJECTION
- ADD ADVANCED RADIATOR CONCEPTS

O THERMAL ACQUISITION AND TRANSPORT

- ADD EFFORT TO BETTER UNDERSTAND 2-PHASE FLOW IN ZERO G BY ANALYSIS AND TEST
- DELAY DEVELOPMENT OF SOME SPECIFIC COMPONENTS UNTIL SPACE STATION NEED IDENTIFIED

O INTEGRATED THERMAL UTILITY

- ADD EARLY FLIGHT DEVELOPMENT TESTS
 - SUPPORT GROUND TEST
 - VERIFY COMPUTER MODELS

Figure 12

INDUSTRY-FUNDED TASKS

Industry-funded tasks are listed in figure 13, but are at a relatively low level. The combined industry IR&D effort probably does not exceed NASA's funded work in thermal technology. Company IR&D will follow the approved program, so until the space station firms up more, this effort should not be counted on for any extensive input.

- 0 SPACE ASSEMBLY SIMULATION
- 0 ROTATING RADIATORS
- 0 COATING MAINTENANCE
- 0 TWO-PHASE HEAT TRANSFER/LOOP CONCEPTS
- 0 HIGH CAPACITY HEAT PIPES

Figure 13

TECHNOLOGY READINESS ASSESSMENT

From the evaluation of the government-funded work and the industry IR&D activity, the technology readiness of heat pipe radiators, two-phase loops, and components is assessed in figure 14. The key message is that many of the systems need a flight test verification because they are gravity sensitive and almost all new thermal systems need a prototype test in the operative ground environment (a thermal vacuum chamber).

	<u>NOW</u>	<u>NEEDED</u>
o <u>RADIATOR</u>		
- HIGH CAPACITY HEAT PIPE	4	7
- RADIATOR/LOOP INTERFACE	4	6
- COATING MAINTENANCE	2	7
- SPACE ASSEMBLY PROCEDURES	2	7
o <u>LOOP</u>		
- TWO PHASE THERMAL BUS	3	7
- INTERFACES	2	7
- AUTOMATED CONTROL/FAULT DETECTION	2	6
- ON ORBIT ASSEMBLY/MAINTENANCE	2	7
o <u>COMPONENTS</u>		
- DISCONNECTS	2	6
- SWIVELS	4	6
- THERMAL STORAGE	2	6

Figure 14

FLIGHT TEST REQUIREMENTS

Flight tests are mandatory in the thermal technology area (fig. 15). Both the radiator and thermal bus have to be designed for zero gravity and they have to be tested in zero gravity to prove that they really work. There are also a number of assembly tasks that can be done to an extent in simulators but at some point it must be demonstrated that the entire system can really go together and function in orbit.

Currently, the plan is missing a Shuttle zero-gravity test bed program that backs up the ground test beds in the plan. The test would have to be conducted on a non-interference basis. Although the Shuttle manifest is full for many years (cannot bump another experiment), it should be possible to use the RMS clearance envelope on flights where a second RMS is not flown. This envelope is roughly a 15-inch-diameter circle that is reserved for the RMS and runs the length of the cargo bay sill line. The radiator and transport loop experiments can be packaged to fit within that envelope. In order for this to happen in the required time frame, work needs to be started immediately on defining a standard instrumentation and interface package. For example, a specific number of temperature measurements, the power level, and the Shuttle heat load limits must be defined.

Quick response procedures should be instituted for the experiments. Safety of flight should be the only requirement. The history on Apollo and other programs is currently inhibiting the innovation of new technology. This history established that experiments be engineered and tested on the ground to accurately predict the flight performance. To reduce development time and cost, this has to change. Experiments should be treated as real experiments; some will work, some will not work (will not provide the expected data), but all must be safe to fly. And the experiments should be conducted on a strict, non-interference basis with the main Shuttle payload to assure that a number of experiments can be flown.

FLIGHT TESTS ARE MANDATORY

- O RADIATOR
 - G SENSITIVE
- O THERMAL BUS
 - G SENSITIVE
- O SPACE ASSEMBLY/MAINTENANCE TECHNIQUES
 - INTEGRATE PROCEDURE (ASTRONAUT/RMS/ASSEMBLY TOOLS)

APPROACH

- O ESTABLISH SHUTTLE ZERO-G TEST BED PROGRAM
 - USE RMS CLEARANCE ENVELOPE
 - STANDARD INSTRUMENTATION/FLUID INTERFACES
 - INSTITUTE QUICK RESPONSE PROCEDURES
 - CONDUCT EXPERIMENTS ON NON-INTERFERENCE BASIS

Figure 15

**SPACE CONSTRUCTABLE HIGH-CAPACITY RADIATOR
FLIGHT VERIFICATION: THERMAL EXPERIMENT**

An example of a radiator flight verification test is illustrated in figure 16. Electrical heat would simulate the two-phase loop heat load that would go into the radiator. The radiator would be mounted along the sill line and radiate its heat into space.

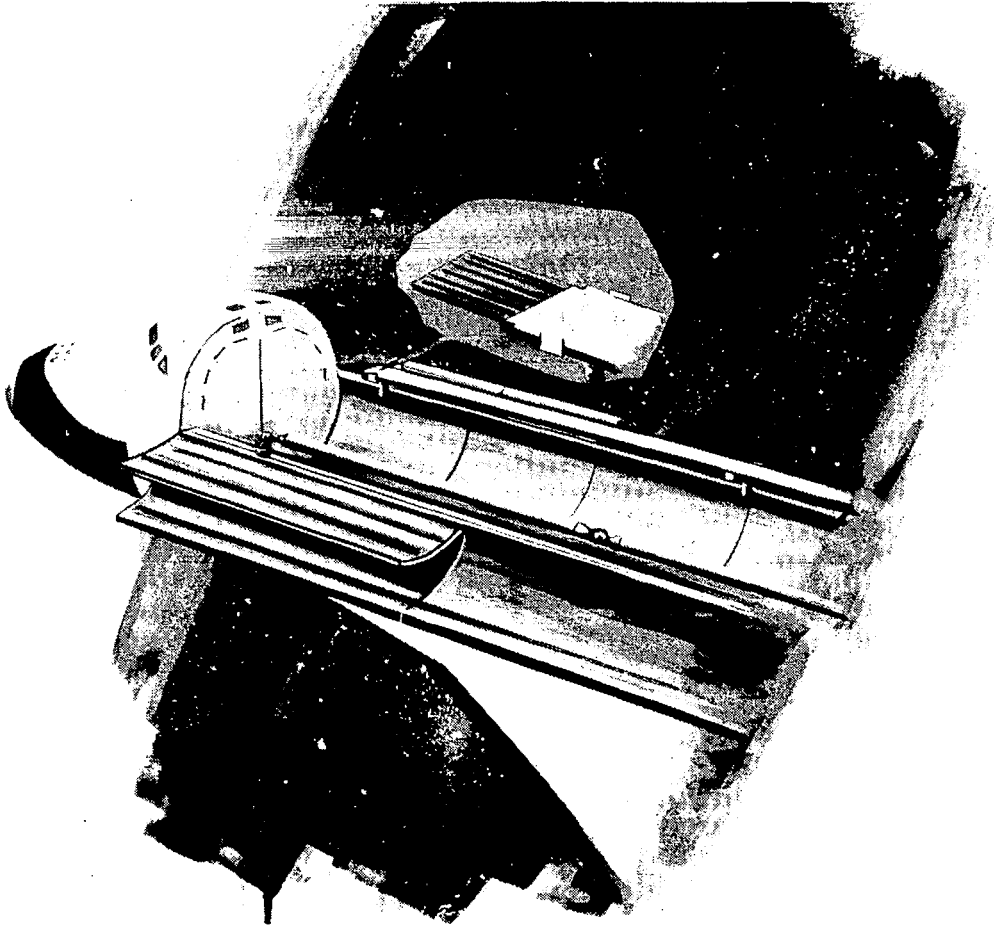

Figure 16

HEAT TRANSFER LOOP FLIGHT TEST ARTICLE

A sketch of a typical heat transfer loop flight test article is shown in figure 17.

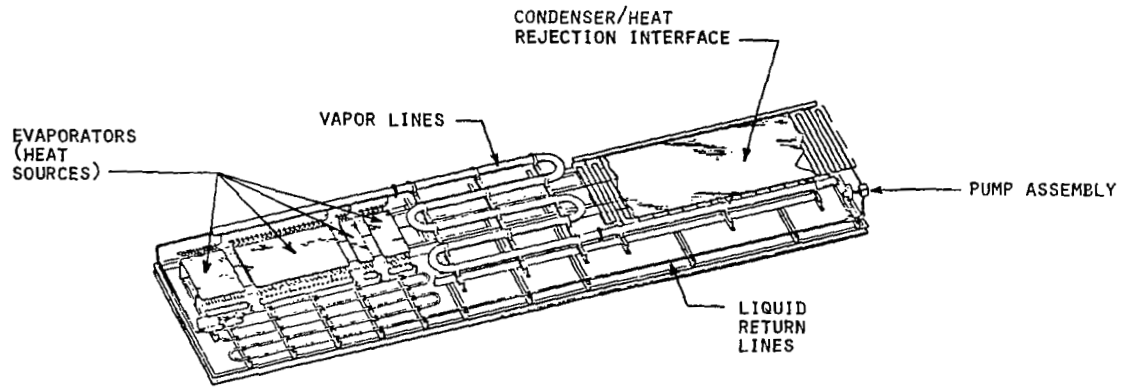

Figure 17

**SPACE CONSTRUCTABLE HIGH-CAPACITY RADIATOR
FLIGHT VERIFICATION: THERMAL EXPERIMENT 2**

Another example of the high-capacity radiator flight test is shown in figure 18. In this test, the heat exchanger is mounted in the cargo bay and the radiator is installed by the remote manipulator arm. Again, the radiator package must be 15 inches wide but could be as long as the cargo bay.

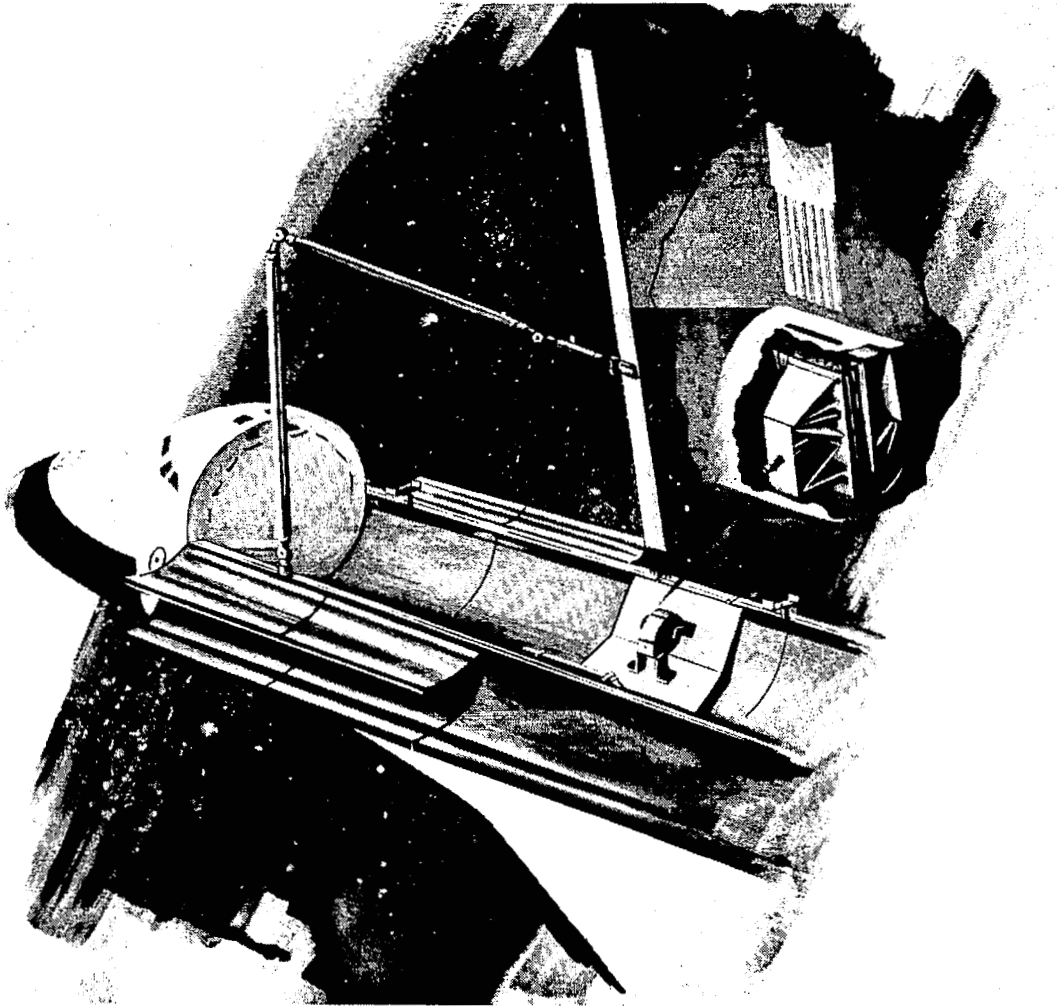

Figure 18

THERMAL BUS TWO-PHASE FLOW/HEAT TRANSFER EVALUATION

More extensive experiments could be conducted on a thermal bus, either hard-mounted in the Shuttle cargo bay or deployable as a free-flyer (fig. 19). These tests should be near-term, with flight experiments in 1985 or 1986 if the technology need date remains 1987.

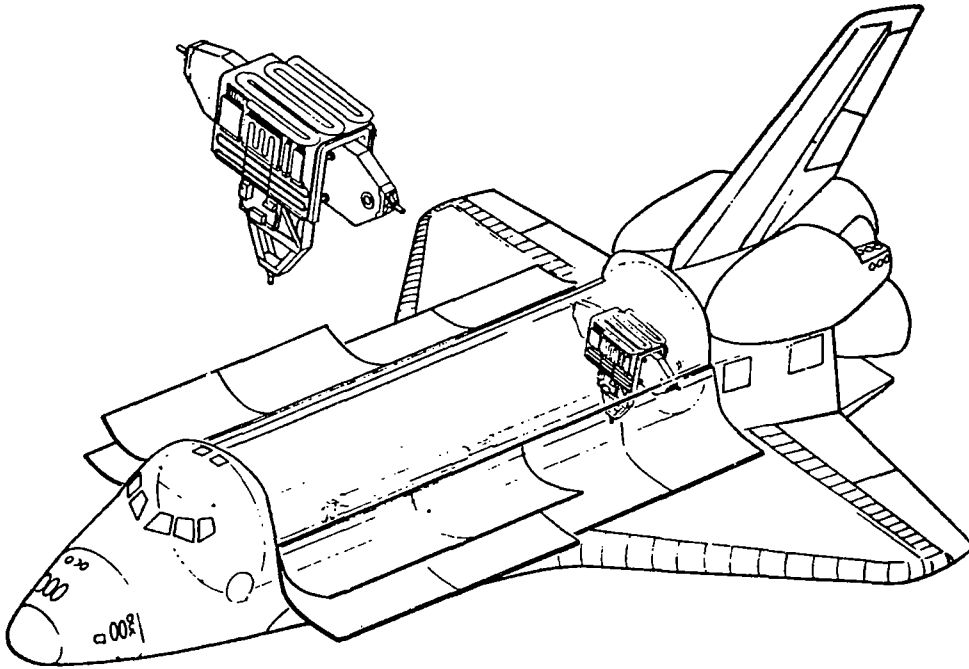

Figure 19

CONCLUSIONS

The panel concluded that the NASA plan is very well conceived (fig. 20). NASA is proceeding with inherently reliable approaches for the space station, as opposed to overkill (reliability with tremendous redundancy). Existing fluid-loop radiators would require isolation valves and sensors and large redundant pumps. The pumps would have to be very efficient and therefore would be designed with little margin. With the new systems, the radiator is a very fail-safe design with a loss of only a percent or two of heat rejection capacity each time a heat pipe is punctured. The flow rates in the two-phase system are so low (small pumps with low power levels) that using several pumps in parallel would provide almost no penalty. The system would be inherently reliable.

Bold approaches are being taken and the panel agreed with this. Money should not be invested for modest improvements in performance. Orders of magnitude improvement in performance can be made across the board in the thermal system. This approach can be taken because there is a clear alternative position, the fluid loop, which will work. However, this is not the best approach, and research should proceed as fast as possible to develop a better system.

In the way of specific critiques, the flight tests which are now shown to be in 1988 and 1989 clearly have a 1987 need date. The only feasible way to do this is to dedicate a zero-gravity test bed concept. To get the test bed and the subsequent flight tests ready, both increased funding and much earlier funding are needed. The NASA plan shows a straight-line increase from a very low level this year to reasonable funding in 1988 and then a plateau in funding for several years. This is not consistent with a 1987 need. The funding has to increase immediately and be relatively high in 1984 and 1985. To go to zero-gravity test beds, the ground test bed program must be accelerated to support those flight tests.

Another inconsistency in the plan involves the issue of survivability. In the current eight architecture studies on the space station, one of the main objectives is to determine how the Air Force (or other military service) might use a space station. The thermal plan did not explore the survivability of these systems. However, since they are inherently more reliable, they are inherently more survivable. Still, more survivable approaches should be pursued for special missions or to enhance the total space station. Lastly, early-on (in the next few years) strengthening of some parallel technology paths is encouraged.

CONCLUSIONS

- 0 NASA PLAN IS WELL CONCEIVED
 - INHERENTLY RELIABLE/MAINTAINABLE DESIGN CONCEPTS
 - BOLD APPROACHES FOR ORDER OF MAGNITUDE IMPROVEMENT
 - CAN FALL BACK TO CURRENT TECHNOLOGY AT LATE DATE

- 0 INDUSTRY CRITIQUE
 - FLIGHT TESTS NEED TO BE CONDUCTED 2-3 YEARS EARLIER
 - NEED INCREASED FUNDING (~ 3 TIMES)
 - NEED EARLIER FUNDING (FY84 & 85)
 - TEST BED ACTIVITIES MUST BE ACCELERATED AND EXPANDED
 - SURVIVABILITY FOR A.F. MISSIONS SHOULD BE CONSIDERED
 - STRENGTHEN PARALLEL TECHNOLOGY PATHS

Figure 20

1. Report No. NASA CP-2293	2. Government Accession No.	3. Recipient's Catalog No.	
4. Title and Subtitle SPACE STATION TECHNOLOGY - 1983		5. Report Date February 1984	6. Performing Organization Code 506-64-13
		8. Performing Organization Report No. L-15732	10. Work Unit No.
7. Author(s) Robert L. Wright and Cathy R. Mays, Editors		11. Contract or Grant No.	
		13. Type of Report and Period Covered Conference Publication	
9. Performing Organization Name and Address NASA Langley Research Center Hampton, Virginia 23665		14. Sponsoring Agency Code	
		12. Sponsoring Agency Name and Address National Aeronautics and Space Administration Washington, DC 20546	
15. Supplementary Notes			
16. Abstract This publication is a compilation of the panel summaries presented at the Space Station Technology Workshop held at the National Conference Center, Williamsburg, Virginia, March 28-31, 1983. The objective of the workshop was to aid the Space Station Technology Steering Committee in defining and implementing a technology development program to support the establishment of a permanent human presence in space. This compilation will provide the participants and their organizations with the information presented at this workshop in a referenceable format. This information will establish a stepping stone for users of space station technology to develop new technology and plan future tasks.			
17. Key Words (Suggested by Author(s)) Space station Space station technology Space station design Space station systems technology Man/systems technology		18. Distribution Statement Unclassified - Unlimited Subject Category 15	
19. Security Classif. (of this report) Unclassified	20. Security Classif. (of this page) Unclassified	21. No. of Pages 193	22. Price* A09

* For sale by the National Technical Information Service, Springfield, Virginia 22161

NASA-Langley, 1984

National Aeronautics and
Space Administration

Washington, D.C.
20546

Official Business

Penalty for Private Use, \$300

SPECIAL FOURTH CLASS MAIL
BOOK

Postage and Fees Paid
National Aeronautics and
Space Administration
NASA-451



NASA

POSTMASTER: If Undeliverable (Section 158
Postal Manual) Do Not Return

S