

N 84 - 18420

**APPLICATIONS OF PHOTOACOUSTIC TECHNIQUES
TO THE STUDY OF JET FUEL RESIDUE**

**FINAL REPORT
COVERING THE PERIOD
22 OCTOBER 1980 - 20 MAY 1983**

**PRINCIPAL INVESTIGATOR: PAUL C. CLASPY
14 NOVEMBER 1983**

**NATIONAL AERONAUTICAL AND SPACE ADMINISTRATION
LEWIS RESEARCH CENTER
GRANT NO. NAG 3-98
NASA TECHNICAL OFFICER: DR. GARY SENG**

**DEPARTMENT OF ELECTRICAL ENGINEERING AND APPLIED PHYSICS
CASE WESTERN RESERVE UNIVERSITY
CLEVELAND, OHIO 44106**

APPLICATIONS OF PHOTOACOUSTIC TECHNIQUES
TO THE STUDY OF JET FUEL RESIDUE

FINAL REPORT
COVERING THE PERIOD
22 OCTOBER 1980 - 20 MAY 1983

PRINCIPAL INVESTIGATOR: PAUL C. CLASPY
14 NOVEMBER 1983

NATIONAL AERONAUTICAL AND SPACE ADMINISTRATION
LEWIS RESEARCH CENTER
GRANT NO. NAG 3-98
NASA TECHNICAL OFFICER: DR. GARY SENG

DEPARTMENT OF ELECTRICAL ENGINEERING AND APPLIED PHYSICS
CASE WESTERN RESERVE UNIVERSITY
CLEVELAND, OHIO 44106

APPLICATION OF PHOTOACOUSTIC TECHNIQUES TO THE
STUDY OF JET FUEL RESIDUE

ABSTRACT

It has been known for many years that fuels for jet aircraft engines demonstrate thermal instability. One manifestation of this thermal instability is the formation of deleterious fuel-derived thermally-induced deposits on surfaces of the aircraft's fuel-handling system. This report presents the results of an investigation of the feasibility of applying photoacoustic techniques to the study of the physical properties of these thermal deposits. Both phase imaging and magnitude imaging and spectroscopy have been investigated. It is concluded that the use of photoacoustic techniques in the study of films of the type encountered in this investigation is not practical.

TABLE OF CONTENTS

Section	Page
1. Introduction and Summary	1
2. Overview of the Photoacoustic Effect	3
3. Experimental Arrangements and Procedures	8
3.1 Photoacoustic Imaging	8
3.2 Photoacoustic Spectroscopy	10
4. Results	14
4.1 Photoacoustic Imaging	14
4.1 Photoacoustic Spectroscopy	14
5. Summary and Conclusions	19
List of References	20

1. INTRODUCTION AND SUMMARY

It has been known for many years that fuels for jet aircraft engines demonstrate thermal instability.(1) One manifestation of this thermal instability is the formation of deleterious fuel-derived thermally-induced deposits on surfaces of the aircraft's fuel-handling system. This report presents the results of an investigation of the feasibility of applying photoacoustic techniques to the study of the physical properties of these thermal deposits.

Various investigations directed toward developing an understanding of the chemistry of residue formation have demonstrated that the entire question of fuel stability is a complex issue.(2) It depends upon both the chemical composition of the fuel and the environment to which it is exposed. On the other hand, however, little attention has been given to the study of their physical properties. For complete characterization of the deposits, information such as thermal conductivity, optical properties, uniformity of deposits, and variation of these characteristics with specific fuel composition, temperature of formation, and substrate on which formed are of value. Since the photoacoustic effect is sensitive to variations in these characteristics, an investigation to determine the practicality of applying that technique was undertaken.

In the course of the investigation photoacoustic techniques were applied to the study of thermal conductivity and film uniformity and to the study of visible and infrared absorption spectra, with primary emphasis being placed on the former two properties. It was found that, while photoacoustic signals can be generated, their

interpretation is difficult at best because of similar effects resulting from variation of each of several parameters. It is concluded that the use of photoacoustic techniques in the study of films of the type encountered in this investigation is not practical.

2. OVERVIEW OF THE PHOTOACOUSTIC EFFECT

The study of physical properties of solids using the photoacoustic effect is an old technique which has seen increased application since 1970, when the use of a laser as the excitation source was first described. In this section the origin of and the type of information available by measuring the photoacoustic effect in solids are discussed.

Consider the system shown schematically in Figure 1a. A sample is mounted in a closed cell and is illuminated by chopped monochromatic radiation. Some of the incident radiation is absorbed by the sample, causing periodic local heating. The amount of radiation absorbed, and therefore the amount of heating, depends on the absorption coefficient of the sample at the wavelength of the radiation.(3),(4) As a result of the local heating, a thermal wave with frequency equal to the light-chopping frequency is produced (5), as shown schematically in Fig. 1a. When this thermal wave arrives at the surface of the sample, the air at the surface is periodically heated, producing an acoustic wave which can then be detected by a microphone. This production of an acoustic wave by optical excitation is the photoacoustic effect. A second means of detecting the wave, and the one used in the work reported herein, makes use of a piezoelectric transducer (6) bonded directly to the sample, as shown schematically in Fig. 1.b. In this case the wave induces an electrical signal in the transducer, eliminating problems of coupling between sample and microphone.

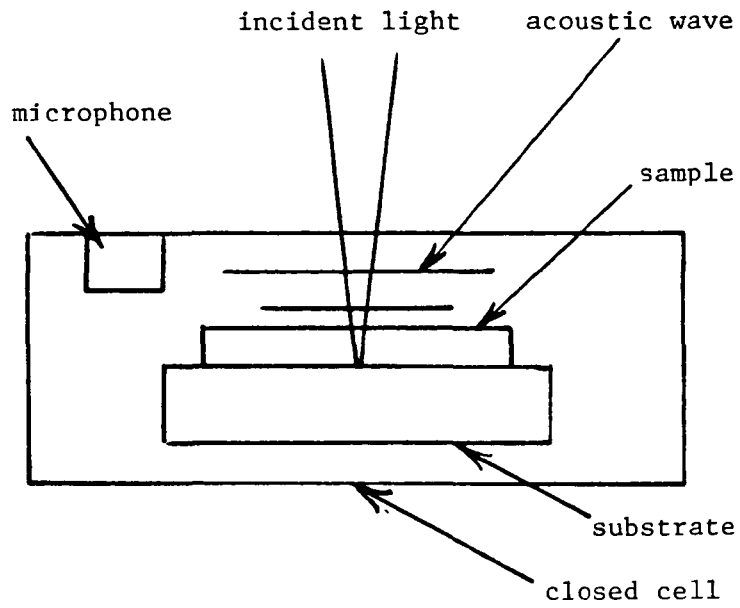

a. Acoustic Wave System

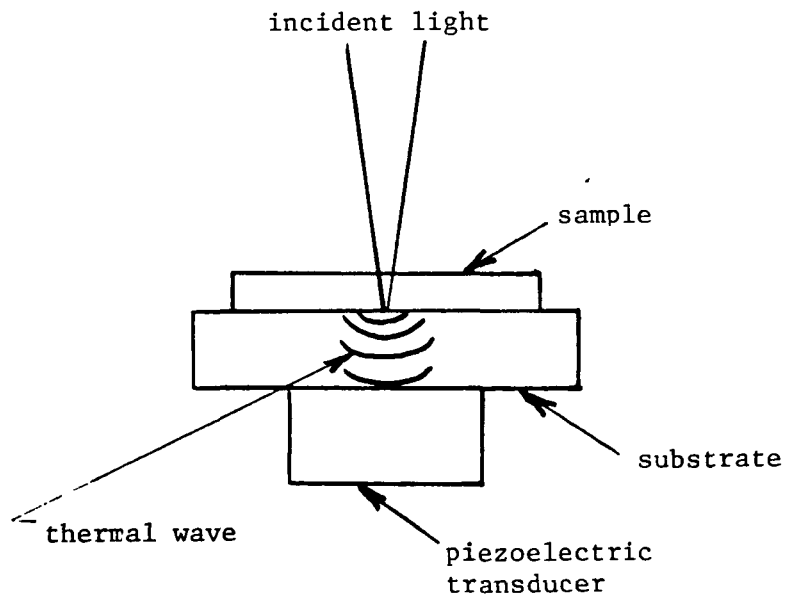

b. Thermal Wave System

Fig. 1. Schematic Photoacoustic Signal Generation

The photoacoustic effect can be used to obtain two general types of information about the sample in which the thermal wave is generated. As observed above, the magnitude of the signal from the transducer is proportional to the absorption coefficient of the sample, making the technique particularly useful for weakly absorbing materials.(7),(8) In principle, then, the absorption spectrum of the sample can be measured by scanning the wavelength of the incident radiation while keeping the point of incidence of the light constant. The relative phase of the signal, on the other hand, is independent of absorption coefficient and depends instead on the time required for the thermal wave to propagate through the sample to the transducer. Thus a study of the relative phase of the signal while the exciting light is scanned over the sample can give information about sample thermal properties.

The difference between the type of information available from magnitude and phase measurements is shown in the experimental results presented in Figure 2. An aluminum sample was prepared as shown in Fig. 2.a. Small holes were drilled in the sample as shown and the sample surface was coated with aquadag in the pattern shown. Plots of amplitude and phase scans (images) are shown in Figs. 2.b and 2.c, respectively. The amplitude image clearly shows the weakly absorbing "X" (where no aquadag was placed) but does not show the internal holes. The phase image, on the other hand, does not show the surface "X" but clearly shows the subsurface holes.

It must be noted that particular care must be exercised in the interpretation of phase data since point-to-point phase variations

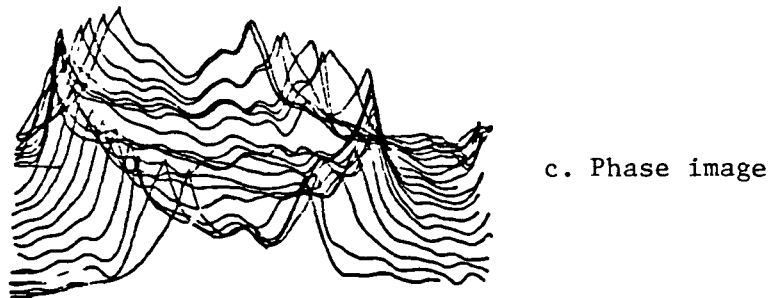
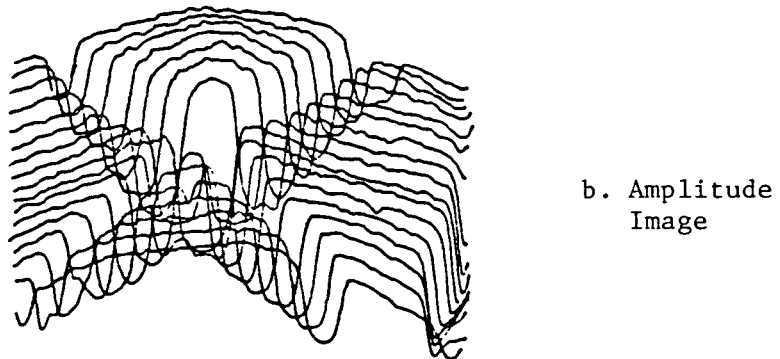
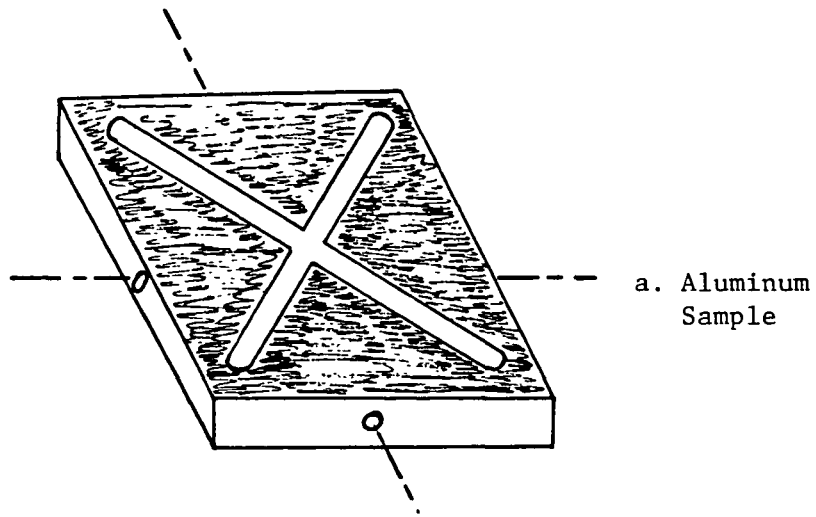

Fig. 2. Amplitude and Phase Imaging

merely indicate variations in propagation time of the wave. These can be caused by sample thickness variations, by voids, or by compositional variations in the sample. Identification of which is the cause in a particular case is not always possible. Interpretation of phase data becomes particularly difficult if the sample is partially transparent to the exciting wavelength since in that case the thermal wave is generated throughout the sample and not just at the surface.

Both types of measurements were made in the course of this investigation with primary emphasis being on the phase measurements. The next section describes the experimental arrangements and procedures used in this research.

3. EXPERIMENTAL ARRANGEMENTS AND PROCEDURES

In this section the experimental arrangements and procedures used in each of the two types of experiments discussed above are described. In all cases the samples were thin films deposited onto stainless steel foil substrates. All experiments were done with the film-substrate combination.

3.1. Photoacoustic Imaging

Photoacoustic imaging is the technique by which the magnitude or the relative phase of the transducer signal is used to obtain a map of the variation of sample properties as the beam is scanned over the sample surface.(4) (As mentioned in the preceding section, interpretation of a phase map must be done with considerable caution.)

The primary light source used in the photoacoustic imaging studies was a HeNe laser operated at 633nm, although some work was done at 3390nm with the HeNe laser and at 488nm using an argon ion laser. In these experiments the samples were mounted on piezoelectric transducers, and the light was scanned over the sample surface in a single line or in a raster-like fashion using a scanner consisting of two galvanometer movement-mounted mirrors, as shown schematically in Figure 3. Signals were measured using a lock-in amplifier operated as a narrow-band vector voltmeter. Magnitude and relative phase of the thermal-wave-generated signal were recorded as a function of position of the exciting beam on the sample. In both cases the exciting wavelength must be kept constant during the scanning.

As discussed above, the photoacoustic phase image is, in effect,

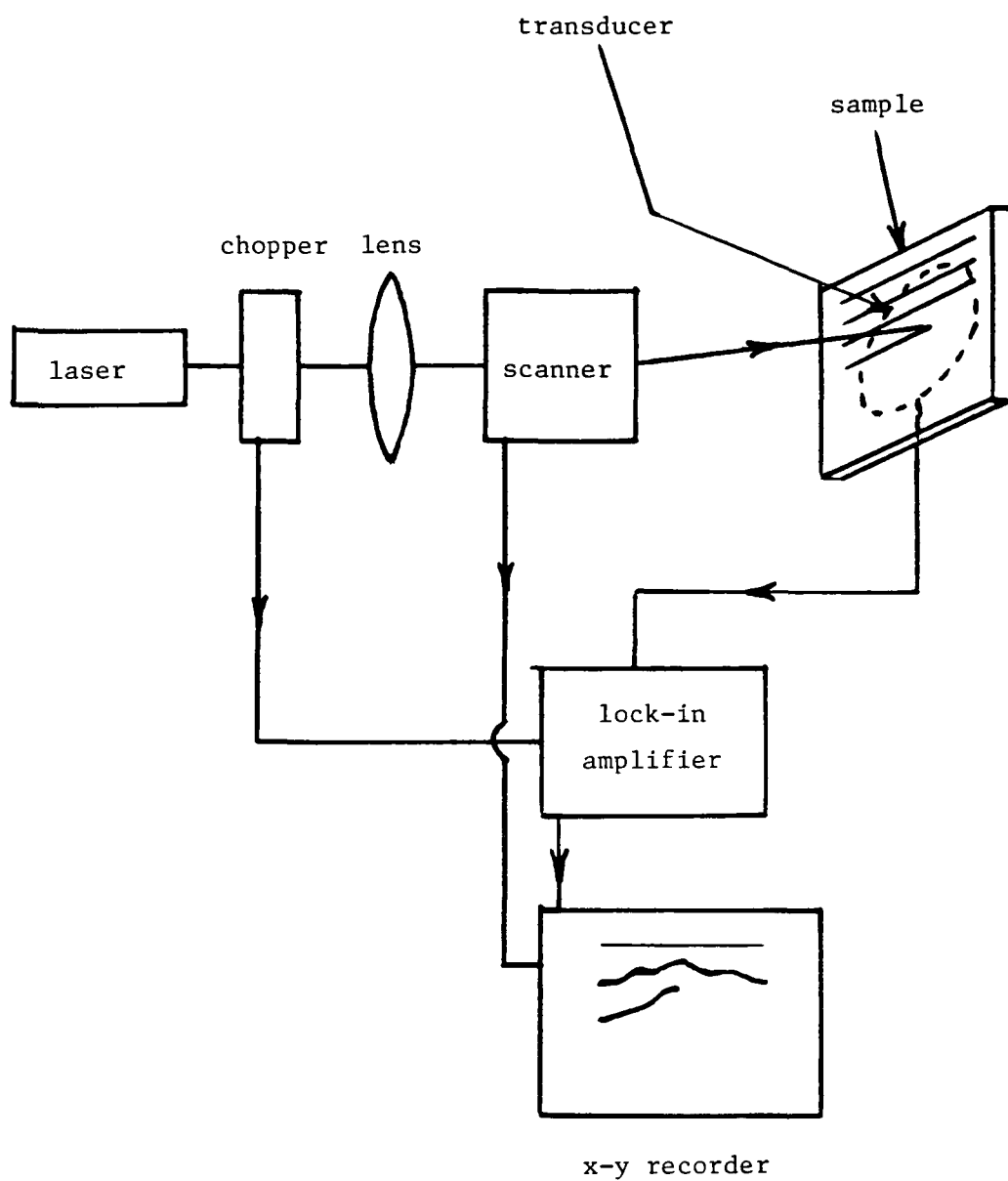

Fig. 3. Scanning Mode Operation

a measure of the point-to-point variation in propagation time of the thermal wave which is generated when the optical radiation is absorbed. It is essential, therefore, that the absorption take place at the sample surface. If this does not occur, thermal waves are generated continuously through the sample, making interpretation virtually impossible. (This problem is described schematically in Fig. 4.)

Since the samples were nearly transparent to the wavelengths available, it was necessary to investigate various coatings and other methods of ensuring that for phase images the absorption occurred at the surface. It was required that the coatings be highly absorbing and of uniform thickness, that they not react with the samples, and that the interface between coating and sample be uniformly transparent to the thermal wave. Aquadag and water-based black paint appeared to be the best choices, although difficulty in data interpretation made the choice of coating a second order effect.

Amplitude images require that absorption occur in the sample and coatings were therefore not used when they were recorded. Other problems, which also occur when optical absorption coefficient is to be measured, must be addressed for amplitude imaging. These are discussed in the next session.

3.2. Photoacoustic Spectroscopy

The experimental arrangement used in this part of the study is shown schematically in Figure 5. The primary light sources were a HeNe laser and a pulsed dye laser, although some work was done with an incoherent source-monochromator combination.

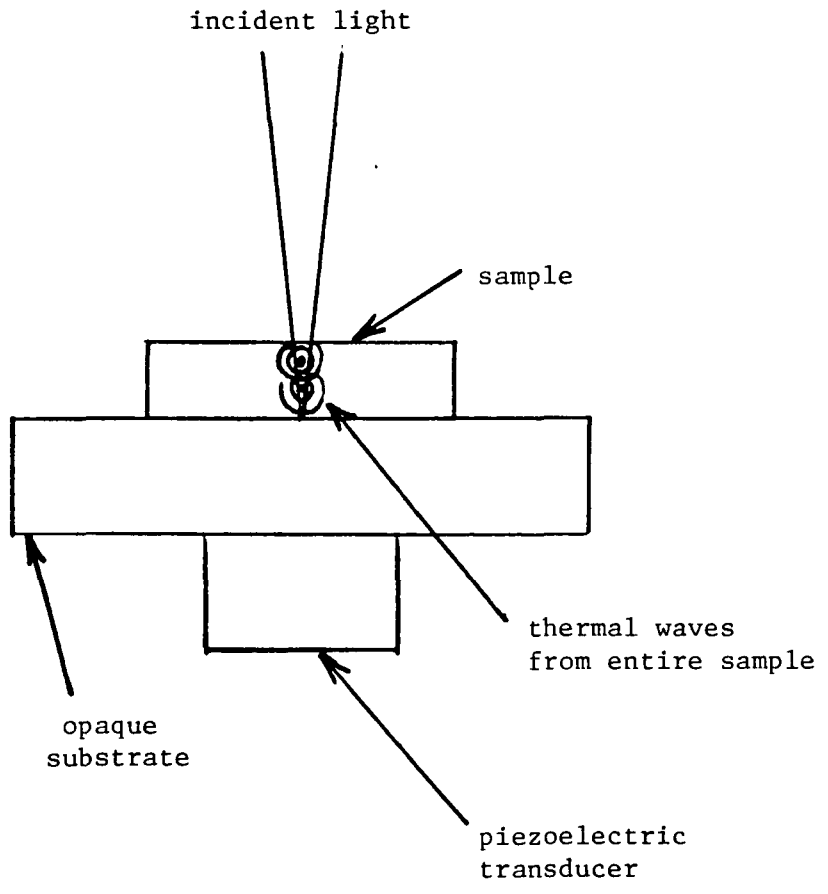

Fig. 4. Thermal Wave Generation in Semitransparent Sample

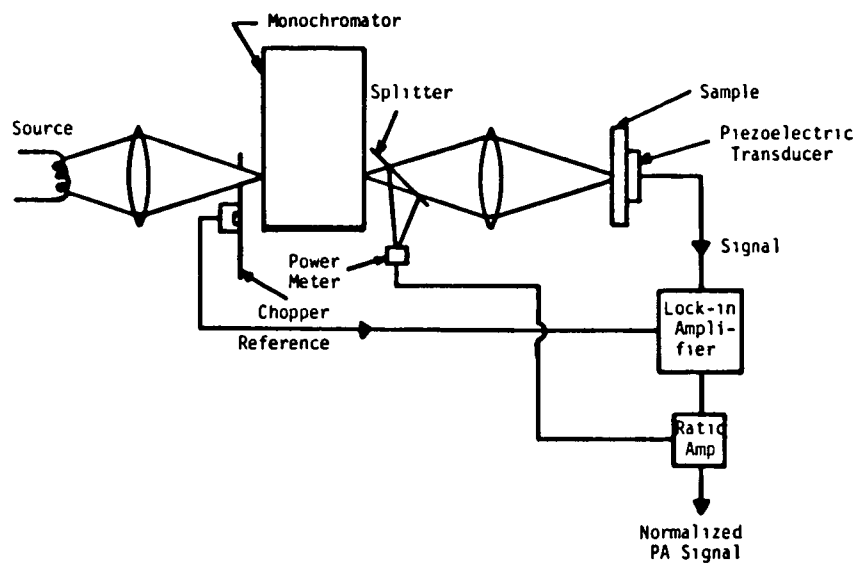

Fig. 5. Experimental Arrangement for Spectroscopy
(First lens and monochromator removed when
laser used)

By interchanging mirrors it was possible to operate the HeNe laser at either 633nm or 3390nm and measurements were taken at each wavelength. The pulsed dye laser contained rhodamine-6G and was used over the range from 585nm to 620nm. The incoherent source was a 500 watt quartz-halogen photographic lamp in series with a 1/4 meter Jarrel-Ash monochrometer. Each of several gratings was used in the monochrometer in an unsuccessful attempt to obtain a viable source for the 1000nm to 3000nm region of the spectrum. To compensate for variation of source output power with wavelength all signals were normalized with respect to incident power.

As in the imaging experiment, samples with their substrates were mounted on piezoelectric transducers. Signals generated by the light were synchronously detected using a lock-in amplifier equipped with a divider circuit which facilitates signal normalization.

To avoid effects of sample nonuniformity, the point of incidence of the light on the sample was kept constant while the wavelength was scanned. In these experiments the objective was to study optical absorption in the samples themselves so no coatings were used. Since the light was directly incident on the samples it was necessary to have the intensity and total power of the light sufficiently low that the sample would not be damaged, while at the same time sufficiently high that detectable signals with a reasonable signal-to-noise ratio could be obtained. As discussed in the next section, it is not clear that this objective was met.

4. RESULTS

In this section some typical results of applying the techniques described above are presented. In all cases the samples were prepared by and provided to us by Dr. Gary Seng of NASA Lewis Research Center, who was Technical Monitor for the program.

4.1 Photoacoustic Imaging

The primary objective of the photoacoustic imaging experiments was to obtain information about the absolute thermal conductivity of the samples and about variations of thermal conductivity with position in the samples from phase images. A typical phase scan of a sample, as well as some amplitude scans of the same portion of the sample, are shown in Figure 6. Since there is no reason to expect that the phase and magnitude images should have similar features (the sample was coated with black paint for the phase measurement), the signal increase in the right third of the traces is most likely due to the transducer. No conclusions about the thermal properties of the samples could be reached from any of the photoacoustic imaging experiments.

4.2 Photoacoustic Spectroscopy

Before attempting to obtain spectroscopic data the effect of incident laser power on a typical sample was evaluated. It was found that the nominal 5mw output of the HeNe laser was sufficiently low that the sample was undamaged by it, but that it was also too low to enable detection of the small variations of absorption coefficient expected in the visible portion of the spectrum. This conclusion was

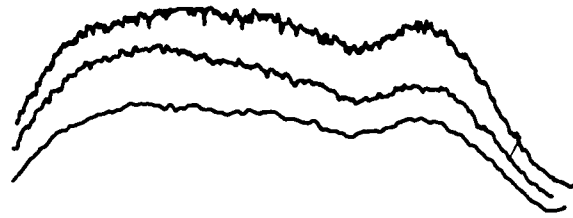

a. Amplitude scan

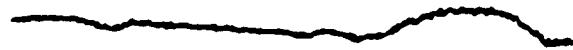

b. Phase scan

Fig. 6. Amplitude and Phase Scans of Same Region
of Typical Sample

reached on the basis of a simple experiment in which light pencil marks, white paint, and some small scratches were placed on a sample which was then used in a magnitude image experiment. It was assumed that each of these imposed features represented a much larger effective absorption coefficient variation than would be found in an "as supplied" sample. The results of typical scans of a sample as supplied and after modification are shown in Figure 7. The overall shape of the scan signal is due to the scan being longer than the diameter of the transducer. (The transducer size effect can be seen more clearly in the amplitude scans in Fig. 8.) As evident from Fig. 7, each of the three white paint marks is clearly identifiable in the signal. Identification of the scratches and the pencil markings, on the other hand, is much less clear, and the signal-to-noise ratio at those features is of the order of unity.

In spite of the above result, the absorption spectrum of each of three samples was measured over the tuning range of the dye laser. For these experiments the dye laser output was reduced to a power level below the threshold for sample damage. The resulting absorption spectra are shown in Figure 9. Although an attempt was made to eliminate effects of laser power variation with wavelength by normalizing the transducer signals to the power, it is felt that the decrease in normalized signal near the ends of the spectral range are residual power variation effects rather than variation of the absorption coefficient.

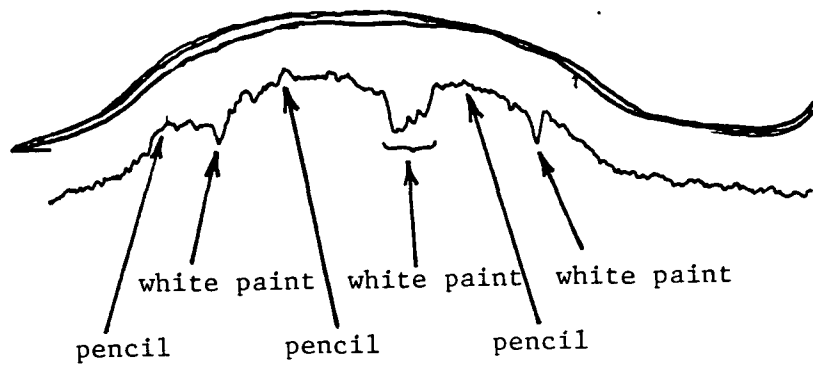

Upper traces: sample as supplied
Lower trace: sample with markings added

Fig. 7. Amplitude Scans

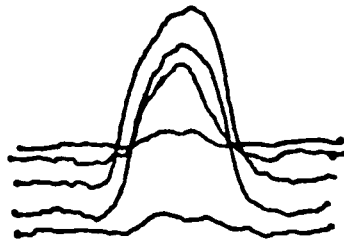

a. Sample from Jet A fuel
with furan additive

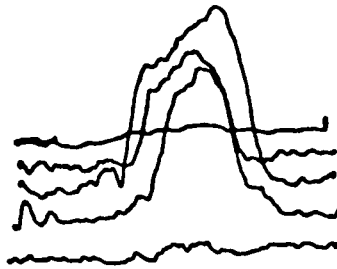

b. Sample from Jet A fuel

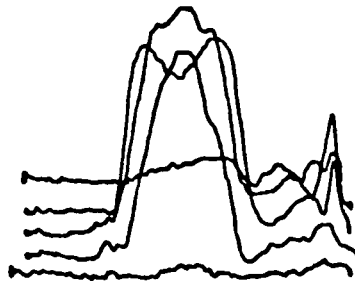

c. Sample from Jet A fuel with
pyrrole additive

Fig. 8. Amplitude Images of Three Samples (in each case
the sample was larger than the transducer)

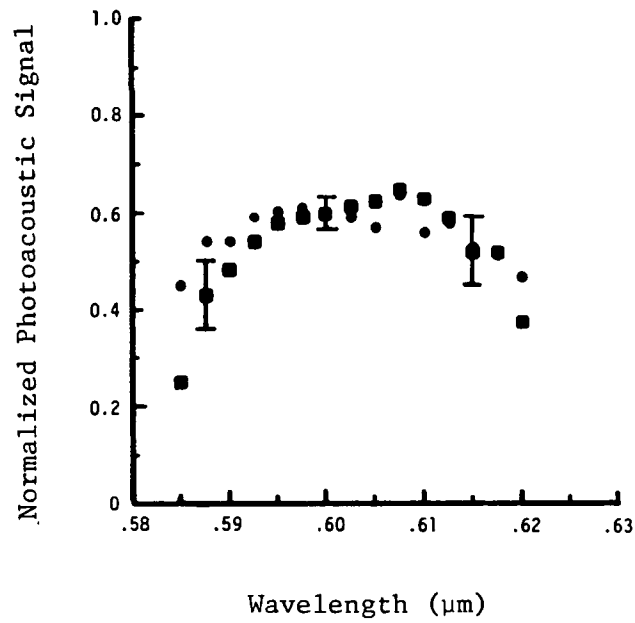

Fig. 9. Absorption Spectra of Typical Samples Using Dye Laser

5. SUMMARY AND CONCLUSIONS

A study has been conducted to determine the feasibility of using photoacoustic techniques to measure optical and thermal properties of films formed by thermal degradation of jet aviation fuels. The result of that study is that because of a combination of small absorption coefficient, film thickness, and film sensitivity to high optical power, useful quantitative information about the characteristics of interest cannot be obtained by this technique.

REFERENCES

1. See, e.g., Watt, J.J., A. Evans, and R.R. Hibbard, "Fouling Characteristics of ASTM Jet A Fuel when Heated to 700Deg.F in a Simulated Heat Exchanger Tube", NASA Technical Note TN D-4958 (1968).
2. Taylor, W.F., ed., "Jet Fuel Thermal Stability", NASA Technical Memorandum 79231 (1979).
3. Rosencwaig, A. and A. Gersho, "Theory of the photoacoustic effect with solids", J. Appl. Phys. 47, pp. 64-69 (1976).
4. Rosencwaig, A., "Theoretical aspects of photoacoustic pectroscopy", J. Appl. Phys. 49, pp. 2905-2910 (1978).
5. Rosencwaig, A. and G. Busse, "High-resolution photoacoustic thermal-wave microscopy", Appl. Phys. Lett. 36, pp. 725-727 (1980).
6. Hordvik, A. and H. Schlossberg, "Photoacoustic technique for determining optical absorption coefficients in solids", Appl. Optics 16, pp. 101-107 (1977).
7. Rosencwaig, A. and T. W. Hindley, "Photoacoustic measurement of low-level absorptions in solids", Appl. Optics 20, pp. 606-609 (1981).
8. Rosencwaig, A. and J. B. Willis, "Photoacoustic absorption measurements of optical materials and thin films", J. Appl. Phys. 51, pp. 4361-4364 (1980).