

N84-18430

NASA TECHNICAL MEMORANDUM

NASA TM-77366

AIR-JET MILLING OF GRINDING MATERIALS

Kazimierz Wozniak and Andrzej Wallisch

(NASA-TM-77366) AIR-JET MILLING OF GRINDING MATERIALS (National Aeronautics and Space Administration) 17 p HC A02/MF A01 CSCL 13I

N84-18430

Unclas  
G3/31 11784

Translation of "Badania dotyczace mielenia materialow sciernych w mlynie powietrzno-strumientowym," Szklo Ceramika, Vol. 32, No. 4, 1981, pp. 69-73



## STANDARD TITLE PAGE

1. Report No. NASA TM-77366		2. Government Accession No.		3. Recipient's Catalog No.	
4. Title and Subtitle AIR-JET MILLING OF GRINDING MATERIALS				5. Report Date November 1983	
				6. Performing Organization Code	
7. Author(s) Kazimierz Wozniak and Andrzej Wallisch				8. Performing Organization Report No.	
				10. Work Unit No.	
9. Performing Organization Name and Address Leo Kanner Associates Redwood City, CA 94063				11. Contract or Grant No. NASw-3541	
				13. Type of Report and Period Covered Translation	
12. Sponsoring Agency Name and Address National Aeronautics and Space Administration, Washington DC 20546				14. Sponsoring Agency Code	
15. Supplementary Notes Translation of "BADANIA DOTYCZACE MIELENIA MATERIALOW SCIERNYCH W MLYNIE POWIETRZNO-STRUMIENTOWYM," Szklo Ceramika, Vol. 32, No. 4, 1981, pp. 69-73. . (N84-18430)					
16. Abstract Principles of air-jet milling of fine powders, influence of air pressure and milling intensity, impact and abrasion, and resultant grain shape are discussed.  <b>ORIGINAL PAGE IS OF POOR QUALITY</b>					
17. Key Words (Selected by Author(s))				18. Distribution Statement Unclassified - Unlimited	
19. Security Classif. (of this report) unclassified		20. Security Classif. (of this page) unclassified		21. No. of Pages 16	22.

Kazimierz Wozniak  
Engineering High School in Koszalina

Andrzej Wallisch  
Research-Developmental Center of the Construction Industry's Chemical  
Institute in Krakow

Grinding materials are used in technology in the form of grains of various size. These grains are obtained by pulverizing clinker or large grains of abrasive materials in various types of pulverizing devices.

The requirements of many of the new technical applications of abrasive materials have lead in recent years to the awakening of interest in the following fields:

- the obtaining of abrasive grains with isometric shapes, differentiated by their large pouring densities,
- the obtaining of tiny abrasive grains (smaller than 45  $\mu\text{m}$ ), which can be fed into devices classifying the size of the abrasive micrograin.

The considerable progress made in the technology of grinding processes and in the technology of grinding instruments with regard to the role of the grain's shape in the processing has aroused great interest in obtaining abrasive grains of various shapes. This especially concerns abrasive grains with isometric shapes, characterized by great mechanical durability and malleability.

The increase in the precision of the grinding of metallic, electronic, glass and ceramic elements has caused a considerable increase in the need for abrasive micrograins.

The development of the domestic grinding industry and the goal of limiting the burdensome import of abrasive grains, including very isometric and micrograins, led to the beginning of work on corresponding equipment and the designing of industrial technology, which would allow the production of these products. Upon surveying the pulverizing equipment used in the domestic grinding industry [1-6], research on the air-jet

milling of grinding materials was begun. This equipment had hitherto been used, above all, in the pharmaceutical, paint and lacquer industries.

The pulverizing process in this device, consisting of striking and filing, has shown that the possibility of obtaining tiny pieces and abrasive grains with isometric shapes exists.

### The Principle of Pulverization in Air-Jet Milling

The grinding in the air-jet mills is called jetting. This consists of pulverization caused by the collision of parts of solid bodies carried by the gas jet decompressed in the nozzles [7, 8].

Illustration 1 presents a simplified schema of the pulverization process in the air-jet mill's grinding chamber. The material for grinding by aid of the Venturi nozzle [11], which can be placed in the upper or lower chamber cover, is placed in the chamber. The material ends up in part "B"--the grinding zone, in which rings with the nozzles are found [3].

/70

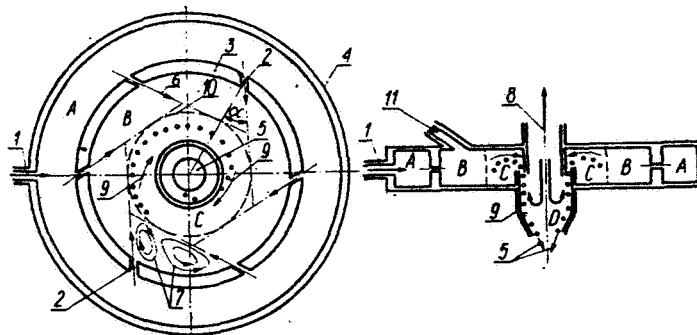

Ill. 1 A simplified schema of the pulverization process in the grinding chamber with the air-jet fluid: A--compressed gas, B--grinding zone, C--classification zone, D--separation zone: 1--compressed air lead, 2--nozzle, 3--rings, 4--external ring of the grinding chamber, 5--product collection, 6. directions of the operation of the work jets, 7--rotation in the grinding zone on the nozzle's surface, 8--outlet for the decompressed gas, 9--direction of the movement of the particles in the separation zone, 10--particles' rotating movement on the edge of the grinding and classification zones, 11--the mill's feed

The manner of pulverization depends on causing collisions between the particles born by the rotating jet and the particles of the jet, whose feeding into the operational area of the work jet (discharged from 6 nozzles) is greatly hurried in relation to the freely moving particles in

the rotating jet. In the mill with a grinding chamber 200 mm at a pressure  $p=0.8$  MPa,  $V=180$  Nm<sup>3</sup>/h,  $Q=13.5$  kg/h,  $\alpha=30^\circ$  according to studies carried out in the Bayer factories in Leverkusen, the speed of the work jet was 450 m/s, and that of the rotating jet 260 m/s.

The pulverized material is introduced along a path with a spiral shape into classification zone "C", where, because of the effect of the centrifugal forces, larger size grains are injected into the area of the activity of the work jets for repeated grinding. Particles with different sizes and masses are small enough and are born into separation zone "D" in which the gas phase is separated from the solid.

It has been shown with the aid of material suitable for triboluminescence, that the pulverization process principally takes place in the extreme zones of the work jets as a result of the mutual penetration of both jets. As long as the diameter of chamber D is smaller than the height of chamber B (for ex.  $D/B=0.1$ ), pulverization will be observed on the rear wall of the work jet induced by the rotating of the gas (ill. 2).

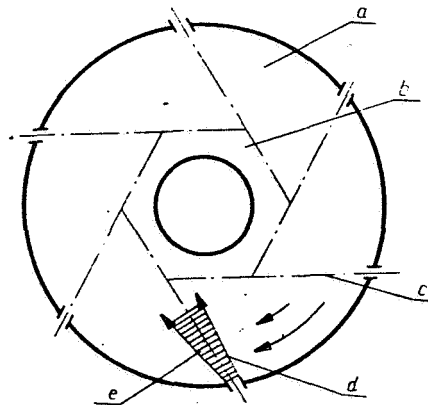

Ill. 2 A cross-section of grinding chamber in zones: a--grinding zone, b--classification zone, c--axis of the work jets, d--front side of the work jet, e--rear side of the work jet

If the proportion  $D/B$  is close to the value .5 or greater, pulverization proceeds on the front and rear sides of the work jet, but with the retention of a small feed amount. The pulverizing ring is created when the feed is increased.

Greater pulverization is not observed near the nozzle at the beginning of the jet. The cause of this phenomenon should be sought in the flow conditions in the jet mill. In the grinding zone a reverse jet, which proceeds along a spiral line in the direction of the ring with the nozzles, also has been observed. Experiments with water have yielded data about the quality distribution of the flows in the grinding chamber.

Presently, we have not been able to measure the fields of speed inside and around the work jets. However, the work jet, which is discharged from the nozzle, flowing through the rotating jet perpendicular to the nozzle's axis, has been experimentally tested. Such an arrangement can be considered in a model flow.

The jet's retention depends on the relation of the energy of the mass of the work jet to the energy of the mass of the rotating jet

$$R = \frac{U_o^2}{U_g^2}$$

where:

$U_o$ --the jet's exiting speed from the nozzle,

$U_g$ --the speed of the rotating jet.

The flow of the jet, therefore, is tested for the condition  $R = 1$ . The qualitative course of this phenomenon is presented by Abramovich [7-8] (ill. 3).

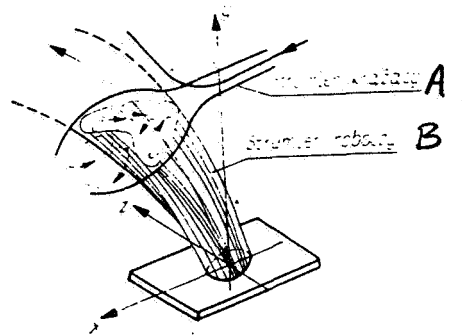

Ill. 3 The work jet flowing through the rotating jet  
A. circulating jet, B. work jet

The speed of the work jet is subjected to braking by the rotating jet which leads to the creation of a superpressure area. Since a very large

speed gradient exists in this instance, the extreme part of the jet is subjected to a cut-out force, in the rear part of the jet the flow is interrupted--this is caused by the creation of an underpressure area from the induction zone.

Under the effects of pressure and the cut-off forces, the jet, which at the nozzle's outlet has a circular profile, is subjected to deformation and along the course of a the short segment, it assumes a kidney-like shape. This jet peters out in the direction of the flow of the rotating jet. Whirls with an opposite direction of movement are formed in the induction zone and flow together with the work jet (a greater energy).

Such whirls are also formed in the work jet with the rotating jet (ill. 4). A pair of whirls newly created in the work jet with the rotating jet sucks in the gas which is flowing in the rotating jet, causing at the same time an intensive rotation.

At the present stage of research it is possible to interpret the phenomenon of pulverization in air-jet milling in this way. One should also recognize that at the present stage of research there is no basis for the introduction of mathematical methods, and only preparatory material can be used for this purpose.

The following parameters of the system have basic significance in the pulverization process in the air-jet mills: the pressure in the collector in the nozzle's intake, the number of nozzles, the nozzles' diameter, the nozzles' angle of slope, the magnitude of the jet feed (output), the size of the fissure between the chamber's cover and the edge of the intake to the cyclone removing the milled product.

/71

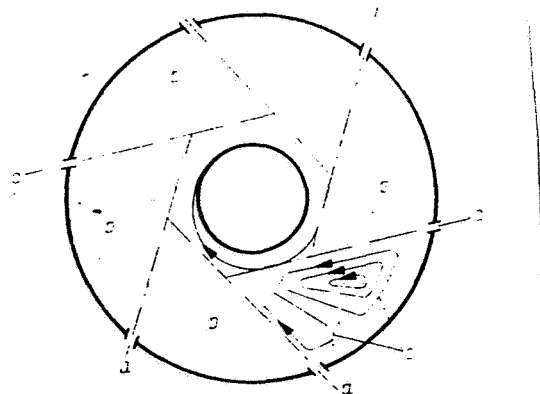

Ill. 4 A model of the flow in the the nozzles' surface: a--the work jet's axis, b--grinding zone, c--whirls in the grinding zone

The pressure of the gas in front of the nozzles decides the kinetic energy of the work jet (the gas jet in the grinding chamber), and therefore, the kinetic energy of the particles of materials carried by the rotating jet and accelerated by the work jet.

The diameter of the nozzles has a direct effect on the range of the work jet. The number of nozzles consists of the frequency of impulses (the frequency of accelerations). The feed size--the amount of materials given for grinding in a unit of time--is of decisive importance, since it determines the powder concentration in the chamber, which in turn determines the corresponding number of collisions between particles. This concentration is decisive for pulverization.

Establishing the constant pressure of the concentration is tied to the material's density and the size of the grains.

Sometimes, it is necessary to perform test grindings for each material in order to set the main parameters which condition optimum grinding. Choosing the corresponding concentration must be a difficult and labor intensive labor. With a too large or too small concentration, the number of collisions is diminished and then the required pulverization level cannot be attained.

The angle of the nozzle's slope affects classification in the grinding. The quality of the classification is improved as the angle of the slope of the nozzle's axis is decreased, since the particles, upon travelling a longer path, reach the classification zone with a slower speed.

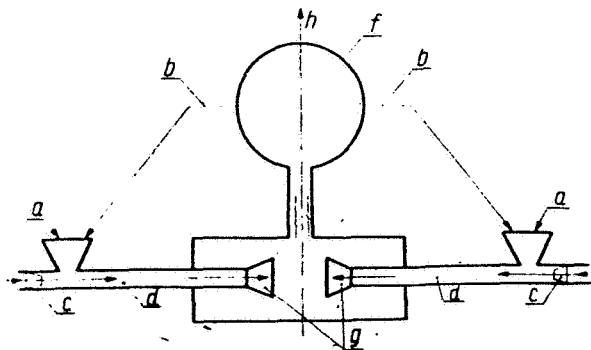

Ill. 5 A simplified schema of the pulverization process in a forced-air mill: a--the feed, b--return of the large grain, c--nozzle, d--jet, f--classifier, g--mixture of gas and material, h--product receptacle



The rotating jet also has a slower speed, which causes the larger particles, as a result of a deficiency of kinetic energy, not to be born into the collecting receptacle. It should be remembered that during the grinding of hard materials, they are better pulverized the larger the kinetic energy of the work jets, or the higher the gas pressure.

MOP (centrifugal steam mills) mills belong to those pulverizing devices whose work jets have greater energy. These mills operate with dry water steam pressure increased to 20 MPa and at a temperature around 300° C, as a result of which the energy of the work jets is incomparably greater than that of the jets of air-jet mills.

Another type of air-jet mill is the forced-air mill (ill. 5). In this mill a mixture of gas and feed is accelerated in the jets. Subsequently, the exiting jets collide and the particles contained in them are pulverized by the collision. After the material passes through the classifier, the too large grains are returned to be reground. Both mills, that is the so-called MPO air-jet mill and the MPP forced-air mill, are mutually differentiated by their design, by their classification operation and their feed and product sections. The MPP type mill serves for a grinding characterized by great output with rougher, cruder feed and product grain.

Although abrasive materials are important for the milling of hard materials, it is necessary to cover the milling chambers as well as other parts of the device, which are joined to the rotating material with anti-erosion facings, such as the agglomerates of aluminum oxide.

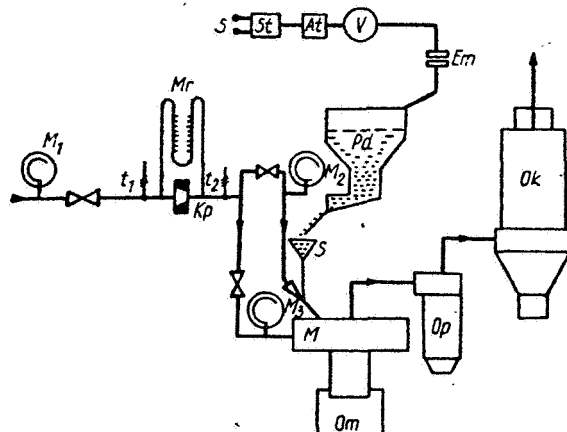

Ill. 6 The schema of a test station for a MPO air-jet mill:  $M_1, M_2, M_3$ --manometers,  $t_1, t_2$ --thermometers,  $K_p$ --measurement cross,  $M_r$ --differential manometer,  $P_d$ --feeder,  $S$ --injector,  $M$ --mill,  $O_p$ --middle air purifier,  $O_k$ --final air purifier,  $S_t$ --voltage stabilizer,  $A_t$

autotransformer, V-voltage meter,  $E_m$ --electromagnet,  $O_m$ --milling product receptacle

### The Experimental Part

The testing station used in research is shown in ill. 6. The MPO-300 air-jet mill used in this station possessed the following parameters:

- milling chamber diameter 300 mm,
- the number of work nozzles--12
- the angle of the slope of the nozzles' axis--.42 rad (24°) and .63 rad (36°),
- work nozzles' diameter--2 and 1.6 mm.

172

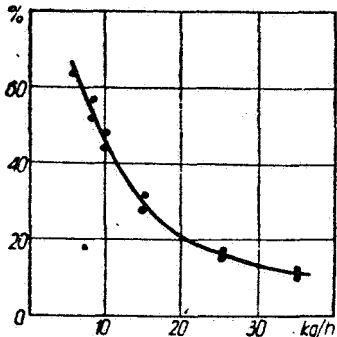

Ill 7. The effect of the output of the grinding of a grain of silicon carbide on the content of a microgranular fragment in the obtained product

The following were measured during tests of the grinding of abrasive materials:

- a) the feed jet  $M_n$  (in kg/h) transported to the mill by aid of a mechanical-vibration doser,

b) the jet of the mass of the work agent--compressed air M in kg/h, measured by aid of an ISA reducer with an attached pressure measurer. The pressure of the accumulation is read out on a differential mercury manometer. The air jet is calculated in accord with PN-65/M-53950,  
 c) the jet of the work agent's energy supplied to the mill N in W calculated as the serviceable power of the jet with a regulation valve at the measurement points of the feed pressure of the mill's nozzle rings:

$$N = \frac{P_d \cdot M}{\rho_p} \quad (W)$$

where:

$P_d$ --the manometric pressure of the ring's feed (MPa),

M--the flow of the work agent in g/h,

$\rho_p$ --the density of the work agent at the measurement points in kg/m<sup>3</sup>,

d) the unit consumption of air  $Z_p$  calculated as the relation of the flow of the air's mass to the flow of the feed mass

$$Z_p = \frac{M}{M_n} \quad (kg/kg)$$

e) the indicator of the consumption of energy  $Z_E$

$$Z_E = \frac{N}{M_n} \quad (Wh/kg).$$

In tests of the milling of three basic abrasive materials, as well as silicon carbide, rare and common electrocorundum, the following was changed:

- the angle of the nozzles' arrangement in the work ring (.42 and .63 rad),
- the pressure of the work air in the nozzles,
- the size of the feed jet directed into the mill.

The Advantage of the Air-Jet Mill for the Obtaining of Abrasive Micrograins

The test feed consisted of grain #40 according to PN-76/M-591115 (335-500 μm). This grain size belongs to the so-called unuseable granulation in the production of abrasive implements and can be designated for further

pulverization.

Illustration 7 shows the effect of the size of the feed jet of a grain of silicon carbide on the content of microgranular fragments in the product obtained from milling. It can be seen, therefore, that the growth in the size of the feed jet causes the minute fragments to be decreased in the obtained product to smaller than  $45 \mu\text{m}$ . These minute grains can only be the feed in the separation line and size classification for the individual granulation of micrograins.

The size of the feed jet also has an important effect on the granulation of the microgranular fragment (ill. 8). The larger the feed jet directed to the air-jet mill is, the more minute the granulation of the microgranular fragment obtained. The granulation of the micrograin was determined by aid of a pipe and sedimentation weight.

The pressure of the work air on the nozzles (ill. 9) also has a key effect on the granulation of the microgranular fragment. With the growth of this pressure, the obtained product becomes even more minute. It is tied to the growth of the kinetic energy of the work jet and to the kinetic energy of the pulverized particle.

It is necessary to work with large work air pressures even with a relatively small feed jet in order to obtain minute microgranular fragments (smaller than  $20 \mu\text{m}$ ).

Comparing the granulation of microgranular fragments of common electrocorundum (ill. 10) with the granulation of fragments of silicon carbide and rare electrocorundum, it can be seen that there are essentially no differences. The share of the determined microgranular sections of the three analyzed abrasive materials are contained within approximately the same limits.

An essential grinding element is also the unit consumption of the operational medium and the unit consumption of energy. With a feed jet size used in the section from 5 to 40 kg/h and a jet of the mass of the work agent between 170 and 260 kg/h, the unit consumption of the work agent fluctuates between 5 and 50 kg/h with a unit consumption of energy from 100 to 1100 Wh/kg.

Air-jet mills, consequently, belong to the group of devices which consume a great deal of energy, in which the cost of electrical energy makes

up an important component in the cost of pulverization. This fact should be considered when making a decision about the selection of a pulverizing device, especially in a period of great energy deficits.

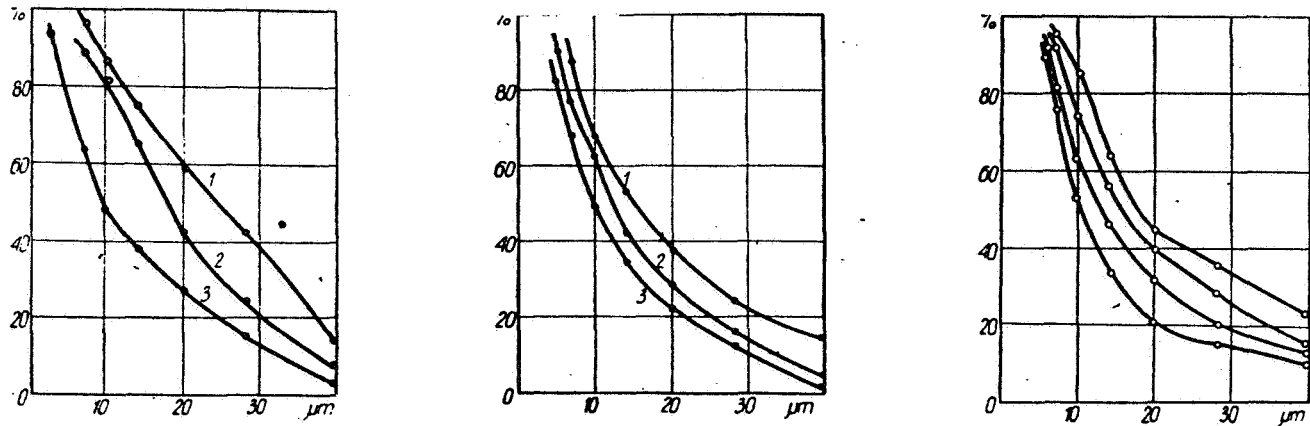

Ill. 8 The granulation of microgranular fragments of silicon carbide with different feed jet sizes: 1--35 kg/h, 2--15 kg/h, 3--5 kg/h

Ill. 9 The granulation of microgranular fragments of rare electrocorundum with different pressures of the work air in the nozzles: 1--.60 MPa, 2--.70 MPa, 3--.77 MPa

Ill. 10 The granulation of microgranular fragments of common electrocorundum obtained in a jet mill

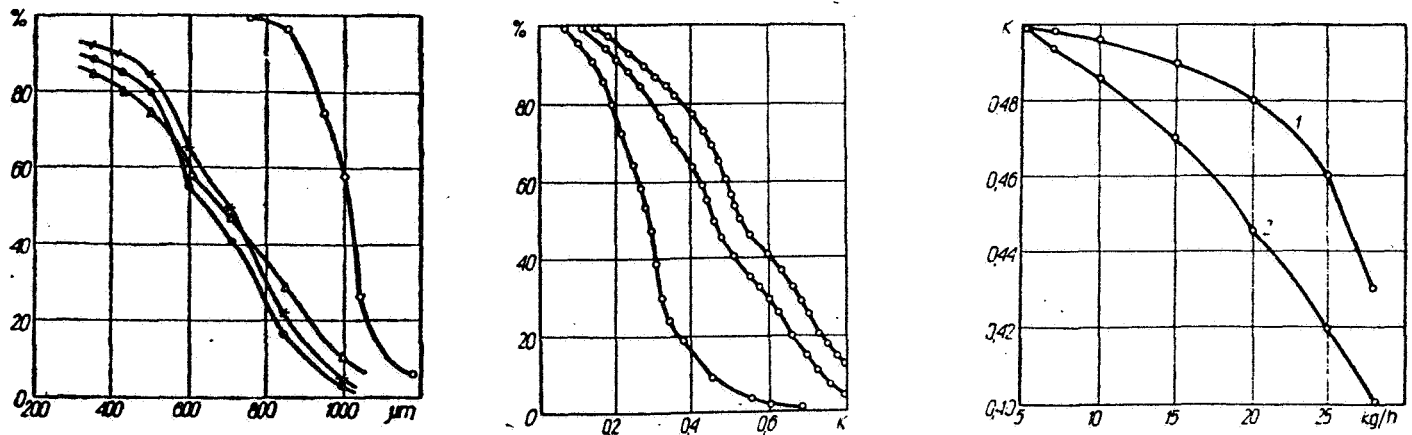

173

Ill. 11 The granulation of the feed and product of the pulverization of abrasive materials in a jet mill: O--feed, ●--rare electrocorundum, x--common electrocorundum, Δ--silicon carbide

Ill. 12 The shape of the grains of the feed (1) and products of the grinding of common electrocorundum (2) and rare electrocorundum (3) with the following grinding parameters:  $M=10$  kg/h,  $P_d=.70$  MPa

Ill. 13 The effect of the jet feed size and the work air pressure on the shape of an obtained grain of silicon carbide: 1--.74 MPa, 2--.69 MPa

!

### The Shape of Abrasive Grains Obtained with the Use of a Jet Mill

The granulation used for testing the grinding of the feed is presented in illustration 11 (this is grain #16 according to PN-76/M-59115). With the application of the parameters of the operation of the air-jet mill, which is similar to the pulverization of a more minute feed used for the obtaining of microgranular fragments, the granulation of the obtained product (illustration 11) of the three abrasive materials is approximately the same. It can be seen from this data that the pulverization, although considerable, does not lead to the entire range of the granulation of grains, which are very necessary from the point of view of the application of abrasives. The shape of the feed grain and that of the product obtained from the pulverization is determined for a chosen size (850  $\mu\text{m}$ ) in accord with the principles given in [9]. The shape of the grain is determined by the coefficient:

$$K = \frac{1 \cdot b \cdot h}{l^3}$$

where:  $l, b, h$  are the dimensions of the cuboid inscribed on the grain, with the principle that  $l > b > h$ .

In illustration 12 is shown the shape of the feed grain and that of the

12

product of the grinding of common and rare electrocorundum. It can be seen from this illustration that the product of the grinding possesses a grain which is considerably more isometrical than the feed grains. The results are exceptionally useful where the coefficients of the shape of the grains obtained with the application of other grinding devices used in the abrasive materials industry are considerably smaller than those obtained with the use of an air-jet mill. It is an important argument which says much for the use of these mills for the pulverization of abrasive materials.

The important possibilities affecting the shape of the obtained abrasive grains are inherent in the choice of grinding parameters (illustration 13). With an increase in the size of the feed jet the abrasive grains' isometrical quality is diminished in the grinding's product. An increase in the isometrical quality of the abrasive grains can be achieved by increasing the work air pressure. With greater pressure values in a smaller level, the isometrical quality of the grain with an increase in the size of the feed jet is lessened.

### Summation

The research results presented show that the air-jet mill is a pulverizing instrument, which can be used for the pulverization of abrasive materials. The high energy consumption required for the pulverization process in this device presents a certain drawback. The achievement of advantageous results in the field of the isometrical quality of the abrasive grains, as well as the greater share of microgranular fragments are further proofs of the advantages of these devices. This especially concerns the installation of the industrial production of abrasive micrograins.

(Article was submitted 20 January 1981)

### Literature

[1] Wozniak K.: The Use of Ring Mills for the Pulverization of Artificial Abrasive Materials. Inz. i Ap. Chem. 1974, #3m p. 16-19

[2] Wozniak K.: The Effect of the Parameters of the Operation of a Bar Mill on the Properties of the Obtained Grain. Inz. i Ap.cchem. 1975, #4, p. 16-19

[3] Wozniak, K.: The Effect of the Parameters of the Operation of a Cylinder Mill on the Properties of the Obtained Grain. Materialy Ogniotrwale, pt I. 1976, #4, p. 79-82, pt. II. 19p77, #1m o, 13-15

[4] Wozniak, K.: Research on the Milling of Electrocorundum with the Use of Vibrating Mills. Maerialy Ogniotrwale, 1977, #4, p. 111-116

[5] Wozniak, K.: The Use of a Concussion Mill for the Grinding of Very Hard Materials. Materialy Ogniotrwale, 1977, #5, p. 144-147

[6] Paziewska, D., Knop L., Lopatka T.: Research on Correcting the Shape of Abrasive Grains in a Rotating Mount and Circular Mill. Szklo i Ceramika, 1979, #7, p. 174-176

[7] Kuerten H., Rumpf H.: Stream Course and Pulverization Parameters in the Spiral Jet Mill. Chemie Ing.-Techn. 1967, #11

[8] Akunov V.: Jet Mills. Moscow, 1967, Masgiz

[9] Wozniak K.: The Determination of the Shape of Abrasive Grains. Szklo i Ceramika, 1975, #8-9, p. 244-248