

## **General Disclaimer**

### **One or more of the Following Statements may affect this Document**

- This document has been reproduced from the best copy furnished by the organizational source. It is being released in the interest of making available as much information as possible.
- This document may contain data, which exceeds the sheet parameters. It was furnished in this condition by the organizational source and is the best copy available.
- This document may contain tone-on-tone or color graphs, charts and/or pictures, which have been reproduced in black and white.
- This document is paginated as submitted by the original source.
- Portions of this document are not fully legible due to the historical nature of some of the material. However, it is the best reproduction available from the original submission.

NASA CR-175199

ST/VE-TR-25066  
31 May 1983

TRACKING AND DATA ACQUISITION SYSTEM  
FOR THE 1990's

VOLUME VII

TDAS SPACE TECHNOLOGY ASSESSMENT

(NASA-CR-175199) TRACKING AND DATA ACQUISITION SYSTEM FOR THE 1990'S. VOLUME 7: TDAS SPACE TECHNOLOGY ASSESSMENT Draft Final Report (Stanford Telecommunications, Inc.) 379 p HC A17/MF A01 CSCL 22A G3/12 12596 N84-19375 Unclas

DRAFT FINAL REPORT

Prepared by:  
Ram Khatri



Prepared for:  
NASA/Goddard Space Flight Center  
Greenbelt, MD 20771



STANFORD  
TELECOMMUNICATIONS INC.

6866 Elm Street ■ Suite 3A ■ McLean, VA 22101 ■ (703) 893-8220

STI/E-TR-25066  
31 May 1983

TRACKING AND DATA ACQUISITION SYSTEM  
FOR THE 1990'S

VOLUME VII

TDAS SPACE TECHNOLOGY ASSESSMENT

DRAFT FINAL REPORT

Prepared by:  
Ram Khatri

Prepared for:  
NASA/Goddard Space Flight Center  
Greenbelt, MD 20771



**STANFORD  
TELECOMMUNICATIONS INC.**

6888 Elm St. • Suite 3A • McLean, VA 22101 • (703) 893-3220

TABLE OF CONTENTS

(TO BE COMPLETED)



## SECTION 1

### INTRODUCTION

With the launch of the first Tracking and Data Relay Satellite (TDRS), many future user spacecraft in low earth orbit will be transmitting data to ground elements via the TDRS System (TDRSS). In the 1990's, the user spacecraft missions will impose data relay requirements to such an extent that all missions will not be supportable with the TDRSS capabilities. Therefore, the Tracking and Data Relay Satellite System of the 1990's must be significantly more capable than TDRSS. The Tracking and Data Acquisition System (TDAS), which is to replace the TDRS in the 1990's, thus requires enhanced capabilities which will support the projected future missions.

As noted, the TDAS Satellite must be a significantly improved version of TDRS. In the Satellite architecture portion of the TDAS Study effort, an investigation was made of the improvements that can possibly be made to the communications modules of TDRS to meet TDAS requirements. The following enhancements are identified for TDAS Satellite implementation:

- S-Band Multiple Access Subsystem (SMA)
- 60 GHz Single Access (WSA) Subsystem
- Laser Communication Subsystem
- Signal Routing Switch
- Multiple Beam Antenna (MBA)
- TDAS Crosslink.

The realization of these enhancements requires the availability of adequate hardware. Hence, the development of support technology to produce the necessary hardware (i.e., the technology essential to the support of Space Segment of TDAS for the 1990's) has been assessed. This includes the previously mentioned TDAS Satellite enhancements as well as associated user

Spacecraft Subsystems. In view of the new TDAS interface requirements (compared with those which now exist for the TDRS) with which the user spacecraft of 1990's must be compatible, it becomes necessary to assess the technology of user spacecraft subsystems. Hence, the technology of the following subsystems of user spacecraft have been assessed:

- 60 GHz High Power Amplifier
- User Spacecraft Antenna System
- On-Board Tape Recorder
- User Spacecraft Attitude Control System
- On-Board Computers.

This report contains the results of the TDAS and user spacecraft technology assessment effort. For each TDAS Satellite enhancement and user spacecraft element previously enumerated, the technology issues are identified and the R&D needed to resolve these issues is delineated. Subsequently, taking into account developments taking place elsewhere, the additional unique TDAS satellite module and user spacecraft element R&D efforts needed are identified, and conclusions are drawn in each case. From these conclusions, it is evident that with additional unique R&D efforts carried out for TDAS and appropriate user spacecraft elements the desired TDAS' capabilities for the 1990's can be realized and user spacecraft can be implemented that adequately interface with the projected TDAS.

## 1.1 OVERVIEW

The Data Relay Satellite of the Tracking and Data Acquisition System (TDAS) of the 1990's will need to be significantly more capable than the Tracking and Data Relay Satellite (TDRS). An effective TDAS Satellite can be realized by augmenting the TDRS design with enhancements which will provide larger capacity, increased access, data accessibility to more locations on the ground, and TDAS satellite crosslink capabilities. Realization of enhanced capabilities will require enhanced communications modules and on-board processing. Because TDAS will impose new interface requirements on its user

spacecraft, a technology assessment of the user spacecraft which addresses these new interface requirements is necessary. In this report, the support technology essential to the development of the Space Segment of TDAS for the 1990's and of compatible user spacecraft is assessed for each needed TDRS enhancement and each applicable user spacecraft element, respectively. Unique R&D efforts needed in this regard are also identified.

PRECEDING PAGE BLANK NOT FILMED

Section 2.0



TECHNOLOGY ASSESSMENT

 STANFORD  
TELECOMMUNICATIONS INC.

2.1

USER SPACECRAFT TECHNOLOGY ASSESSMENT

STANFORD  
TELECOMMUNICATIONS INC.



2.1.1

60 GHZ HPA TECHNOLOGY

 STANFORD  
TELECOMMUNICATIONS INC.

60 GHZ HPA TECHNOLOGY

The various elements of this section of the report are listed in the chart.



## 60 GHZ HPA TECHNOLOGY

- HPA REQUIREMENTS FOR TDAS USER S/C
- COMPARISON OF CANDIDATE APPROACHES
- HPA POWER COMBINING TECHNIQUES
  - VARIOUS TECHNIQUES
  - COMPARISON
- CURRENT AND PROJECTED CAPABILITIES
- TECHNOLOGY ISSUES AND R&D NEEDED
- HPA UNIQUE R&D NEEDED
- CONCLUSIONS

VII-2-9



STANFORD  
TELECOMMUNICATIONS INC.

## HPA REQUIREMENTS FOR TDAS USER SPACECRAFT

Key requirements for the 60 GHz HPA are listed. Power requirement is dictated by data rate and link parameters. It should be a light weight assembly so that the user spacecraft (S/C) is not overly burdened with weight. It is unlikely that a single HPA unit can satisfy the stated output power requirements. Thus, the outputs of an adequate number of units must be combined to achieve the desired power. Combiners are used for combining the power outputs of HPA units with attendant combining losses, resulting in a combiner efficiency less than 100%. In order to achieve required output by combining a minimum number of units, it is desirable to achieve the highest possible combiner efficiency; ninety percent (90%) is considered an achievable and realistic objective.

## HPA REQUIREMENTS FOR TDAS USER SPACECRAFT

<u>PARAMETER</u>	<u>REQUIREMENT</u>
OPERATING FREQUENCY	60 GHZ (1)
OUTPUT POWER	$\geq 10$ W
PRIME POWER	LOWEST POSSIBLE (HIGHEST POSSIBLE EFFICIENCY)
W GHT	LIGHT
COMBINER EFF:	$> 90\%$

(1) NOTE: SINCE HPA TECHNOLOGY AT 60 GHZ IS MOST CRITICAL, ONLY THIS BAND IS ADDRESSED.

VII-2-11



STANFORD  
TELECOMMUNICATIONS INC.

## COMPARISON OF TWO CANDIDATE HPA APPROACHES

Two candidate approaches are viable for the 60 GHz HPA units; these are:

- Traveling Wave Tube Amplifier (TWTA)
- Solid State Power Amplifier (SSPA).

A comparison of the two candidate HPA approaches on the basis of key parameters is tabulated.



## COMPARISON OF TWO CANDIDATE HPA APPROACHES

<u>PARAMETER</u>	<u>TWTA</u>	<u>SOLID STATE HPA</u>
OUTPUT POWER	HIGH	LOW
GAIN	HIGH	LOW
EFFICIENCY	HIGH	LOW
BANDWIDTH	BROAD	MEDIUM
NEED FOR NEW COMPONENT DEVELOPMENT	<ul style="list-style-type: none"><li>● CATHODE</li><li>● HIGH VOLTAGE POWER SUPPLY</li><li>● COUPLED CAVITY TWT</li></ul>	<ul style="list-style-type: none"><li>● EFFICIENT POWER COMBINERS</li></ul>
FABRICATION TECHNOLOGY	DIFFICULT UNPROVEN	EASY UNPROVEN

VII-2-13



STANFORD  
TELECOMMUNICATIONS INC.

## HPA POWER COMBINING TECHNIQUES

HPA power output can be enhanced by combining at two levels:

- First Level Combining (Combining at Chip Level)
- Subsequent Combining.

First Level Combining enhances the output power of the basic chip, while Subsequent Combining techniques provide the means for combining the outputs of HPA units.

Functional Block Diagrams of Candidate subsequent power combining techniques are next given. The candidate techniques are:

- Resonant Cavity Combiner
- N-Way Power Combiner
- Spatial Power Combiner
- Binary Combiner.

# HPA POWER COMBINING TECHNIQUES

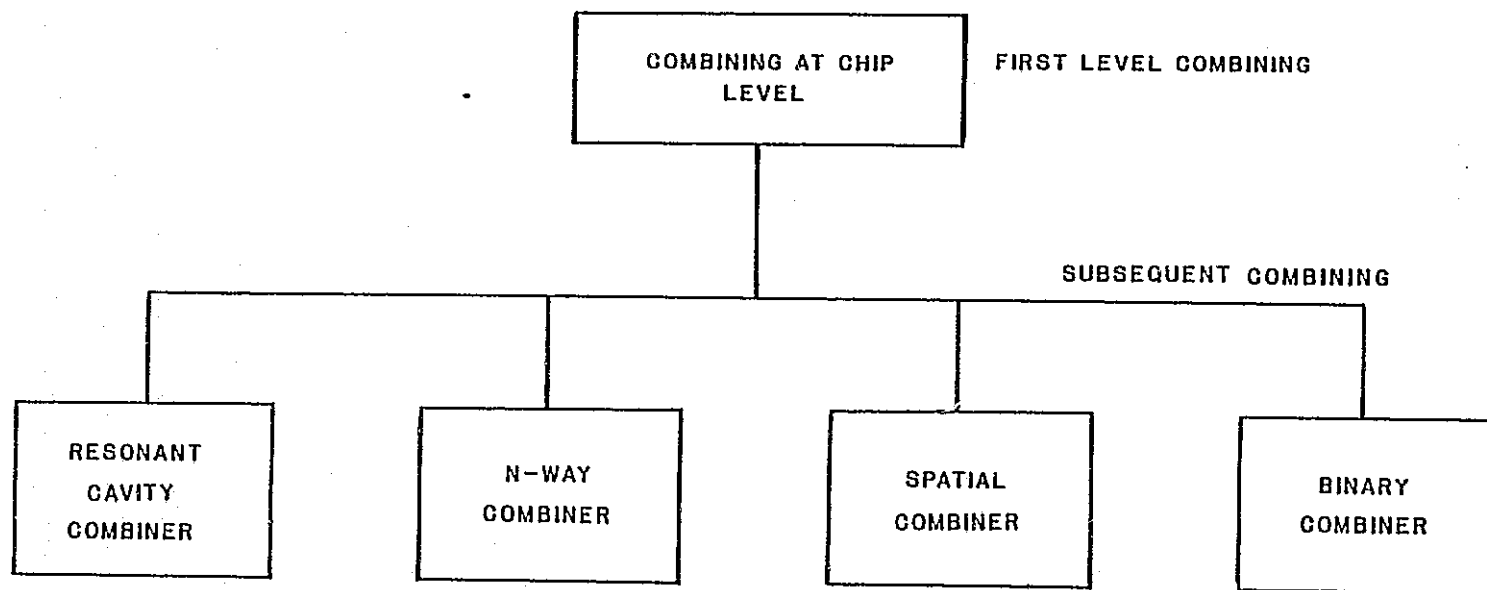

VII-2-15



STANFORD  
TELECOMMUNICATIONS INC.

RESONANT CAVITY COMBINER

A Resonant Cavity Combiner consists of a waveguide cavity into which several units are coupled by means of electromagnetic fields in the cavity.

ORIGINAL PAGE 15  
OF POOR QUALITY

RESONANT CAVITY COMBINER

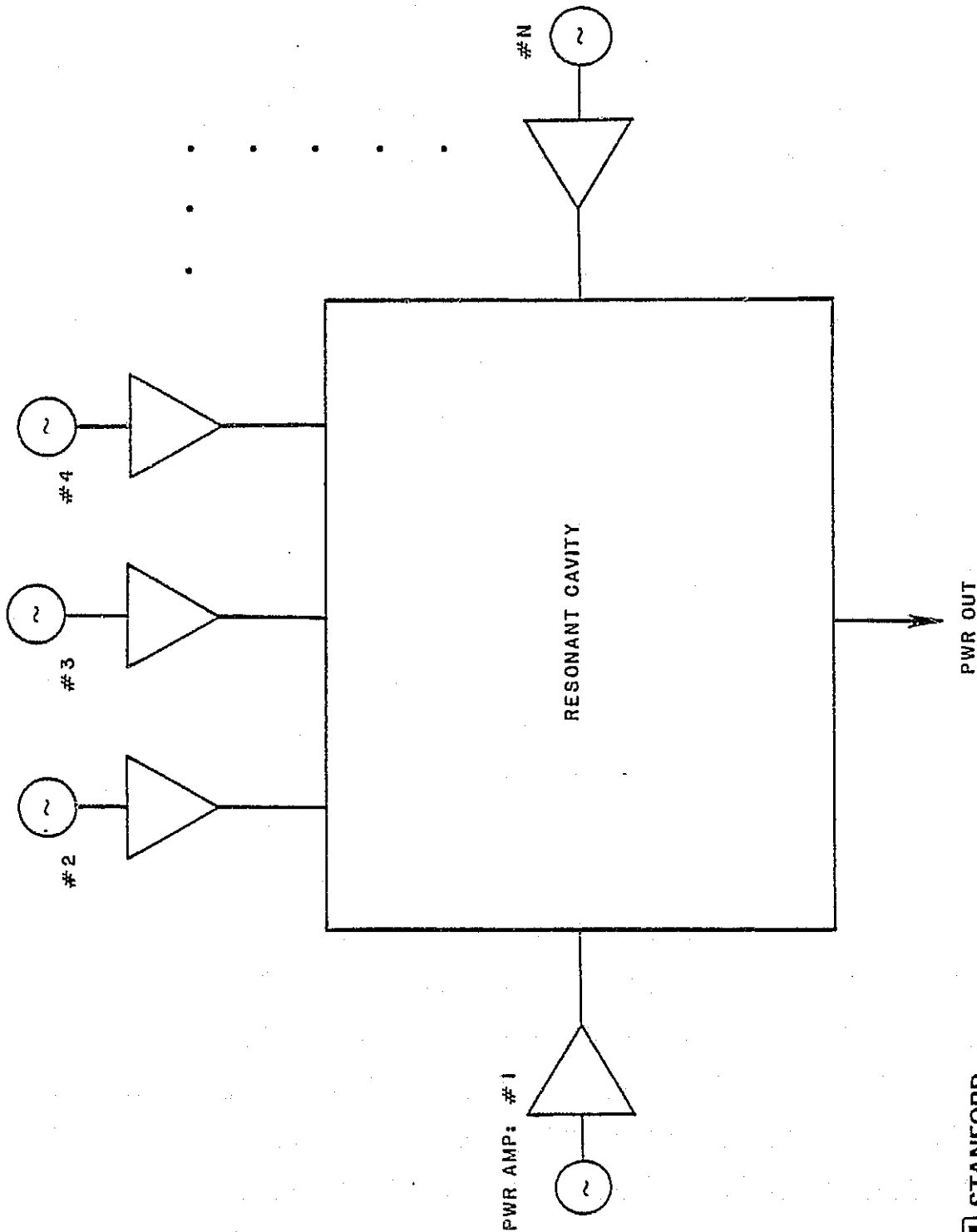

STANFORD  
TELECOMMUNICATIONS INC.



## N-WAY POWER COMBINER

In an N-way Combiner, a single N-way power divider feeds the N individual amplifiers which are subsequently recombined with a single N-way combiner at the output. The loss of only one combiner is encountered at both the input and output.

ORIGINAL PAGE IS  
OF POOR QUALITY

N-WAY POWER COMBINER

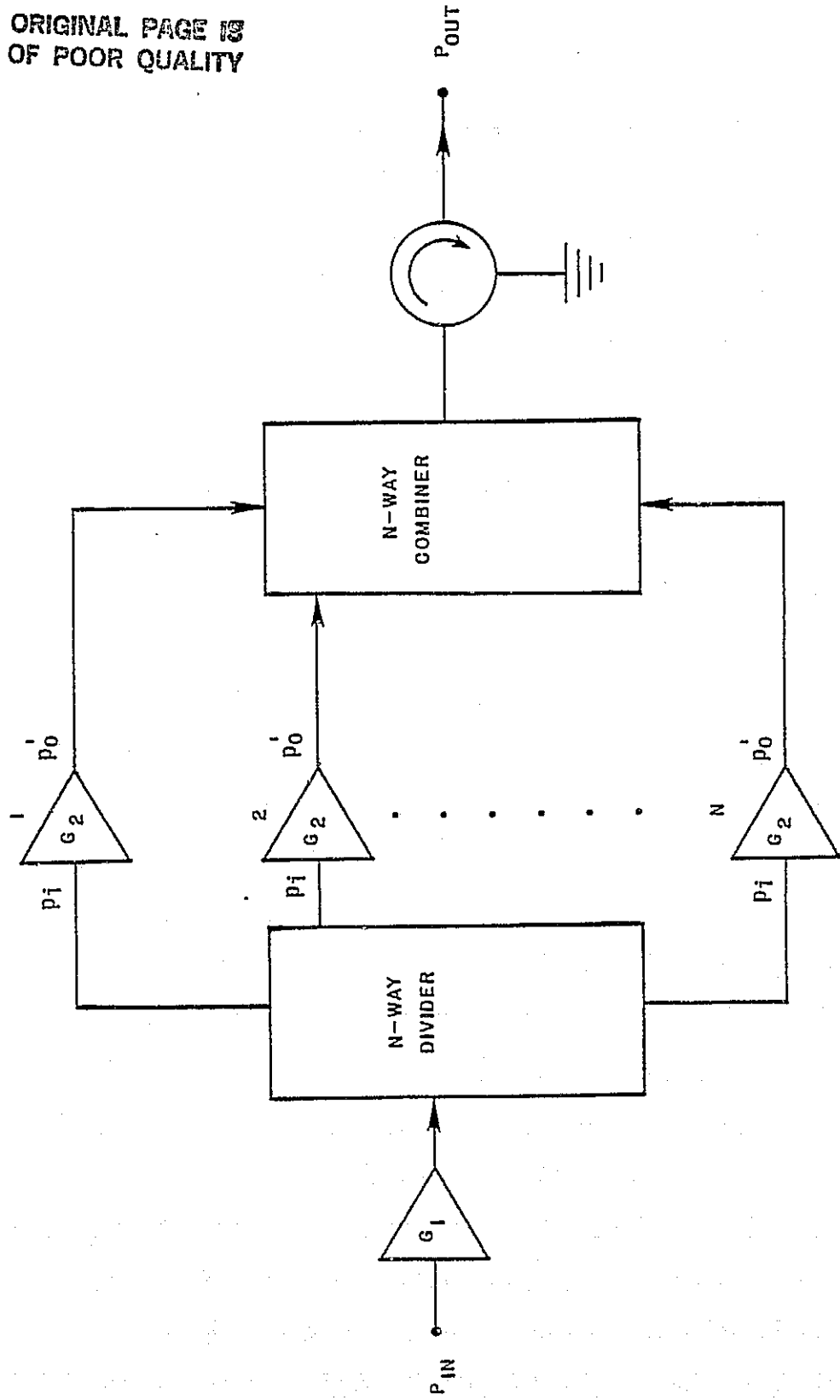

STANFORD  
TELECOMMUNICATIONS INC.



## SPATIAL POWER COMBINER

In a Spatial Combiner, the individual amplifiers are driven from an N-way power divider. Each amplifier drives its own antenna element. The power through each amplifier is phased such that the total power radiated by the antenna recombines in an additive manner.



ORIGINAL PAGE IS  
OF POOR QUALITY

SPATIAL POWER COMBINER

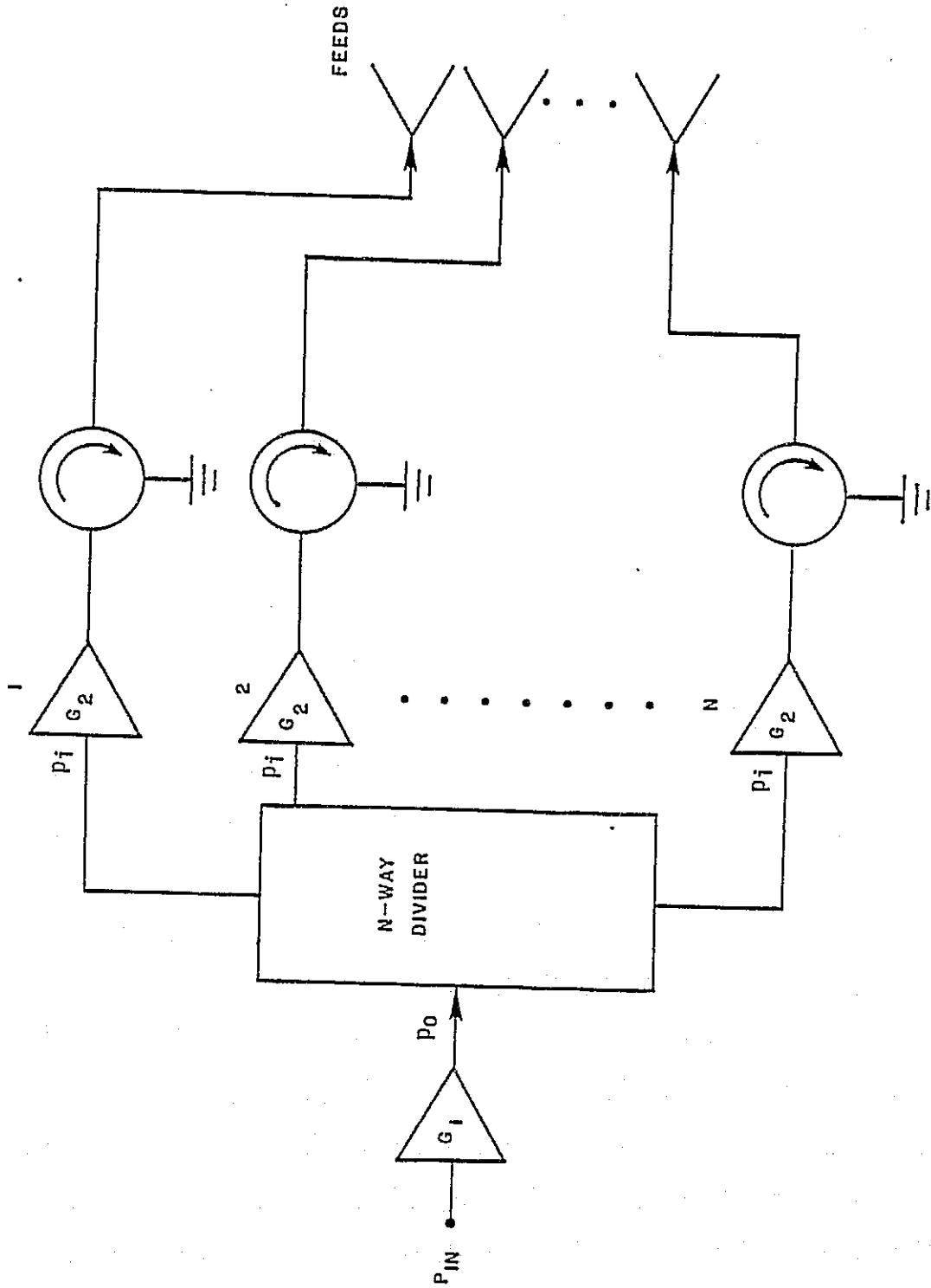

**STI** STANFORD  
TELECOMMUNICATIONS INC.

## BINARY COMBINER

A Binary Combiner is implemented with quadrature hybrids in which each pair of amplifiers is fed by the divided power output of a quadrature hybrid, taking care that the power from each amplifier pair recombines in phase. 'L' represents the insertion loss of each hybrid.

# BINARY COMBINER

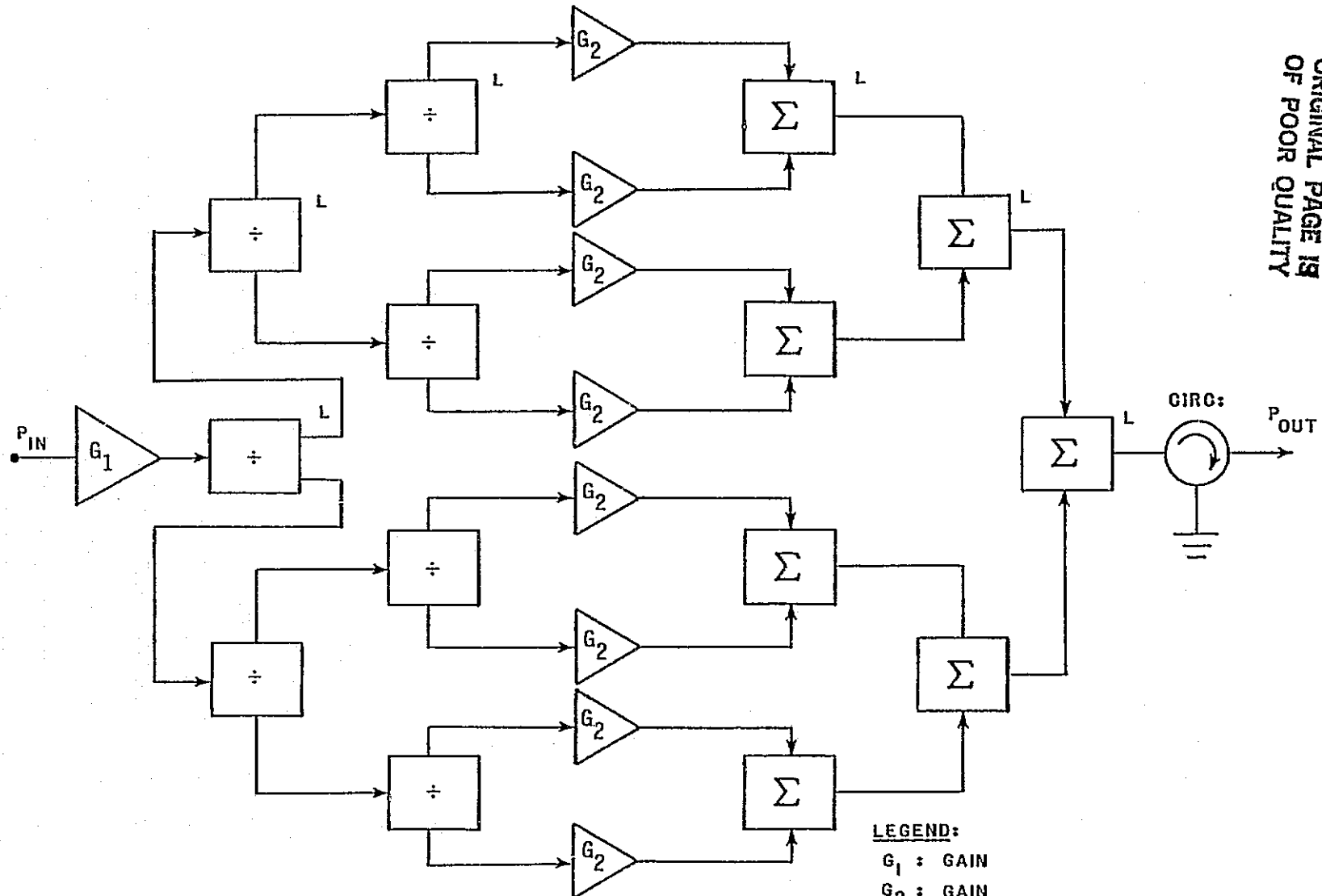

**LEGEND:**  
 $G_1$  : GAIN  
 $G_2$  : GAIN  
 $\div$  : DIVIDER  
 $\Sigma$  : COMBINER  
 L : LOSS

ORIGINAL PAGE IS  
OF POOR QUALITY

VII-2-23



**STANFORD TELECOMMUNICATIONS INC.**

COMPARISON OF POWER COMBINING TECHNIQUES

Advantages and disadvantages of the various Subsequent Level power combining techniques are tabulated. On the basis of the comparison, the Resonant Cavity combiner appears to be the most promising candidate.

## COMPARISON OF POWER COMBINING TECHNIQUES

TECHNIQUE	ADVANTAGES	DISADVANTAGES
RESONANT CAVITY COMBINER	HIGH COMBINING EFFICIENCY SMALL SIZE LIGHT WEIGHT	NARROW BANDWIDTH USABLE UP TO $\approx 10$ DEVICES
N-WAY COMBINER	LOW INSERTION LOSS SMALL SIZE LIGHT WEIGHT USEABLE FOR ANY VALUE OF N	DIFFICULT TO IMPLEMENT
SPATIAL COMBINER	LOW INSERTION LOSS EASY TO IMPLEMENT	REQUIRES COMPATIBLE ANTENNA DESIGN
BINARY COMBINER	EASY TO IMPLEMENT	HIGH INSERTION LOSS LARGE SIZE HEAVY USABLE UP TO $\approx 16$ DEVICES

VII-2-25



STANFORD  
TELECOMMUNICATIONS INC.

OUTPUT POWER CAPABILITIES OF SPACE TYPE TWT'S (W)

The output power capabilities of space type TWT's in watts is profiled. Although our primary interest concerns a frequency of operation of 60 GHz, other bands are included because they are relevant to TDAS. At 60 GHz, in a development program at Hughes/RADC, a power output of 5W was obtained. The development effort met the program objectives. A reasonable range for the projected output of 60 GHz TWTs in the 1985-1990 time frame is 5-50W if the Coupled Cavity Design effort is maintained and output power objectives are continuously enhanced.

## OUTPUT POWER CAPABILITIES OF SPACE TYPE TWT'S (W)

FREQUENCY	CURRENTLY AVAILABLE	TWT STATUS		BASIS OF PROJECTION
		UNDER DEVELOPMENT	1985-1990's PROJECTION	
S-BAND	8 - 300	-	800 - 1000	ONLY SPECIAL NEEDS WILL MOTIVATE DEVELOPMENT
KU-BAND	1 - 250	20(4)	600 - 700	
20 GHZ	2 - 30	15 - 75(5)	30 - 100(1)	AEG TELEFUNKEN HAS A PARTIALLY DEVELOPED LAB MODEL WHICH HAS YIELDED A MAXI OUTPUT OF 700 W
30 GHZ	2 - 10	-	10 - 50(1)	PRESENT DEVELOPMENT ACTIVITY AND USE OF COUPLED CAVITY TWT
60 GHZ	-	5(2)	5 - 50(3)	IF COUPLED CAVITY TWT DEVELOPMENT IS INITIATED
				IF COUPLED CAVITY TWT ACTIVITY IS MAINTAINED

NOTES: (1) THE PROJECTED CAPABILITY IS BASED UPON THE USE OF COUPLED CAVITY TWT WHICH NEEDS DEVELOPMENT.  
 (2) THIS IS AN ENGINEERING FEASIBILITY MODEL OF 60 GHZ, 5W COUPLED CAVITY TWT UNDER DEVELOPMENT (HUGHES/RADC).

- (4) HUGHES.  
 (5) HUGHES.

CURRENT AND PROJECTED CAPABILITIES OF SOLID STATE (IMPACT) SOURCES

This graph shows the current and projected CW power output capabilities of solid state (IMPATT) sources. It is projected that, in the 1985-1990 time frame, such sources will yield approximately 2.5W of output power at 60 GHz.



# CURRENT AND PROJECTED CAPABILITIES OF SOLID STATE (IMPATT) SOURCES

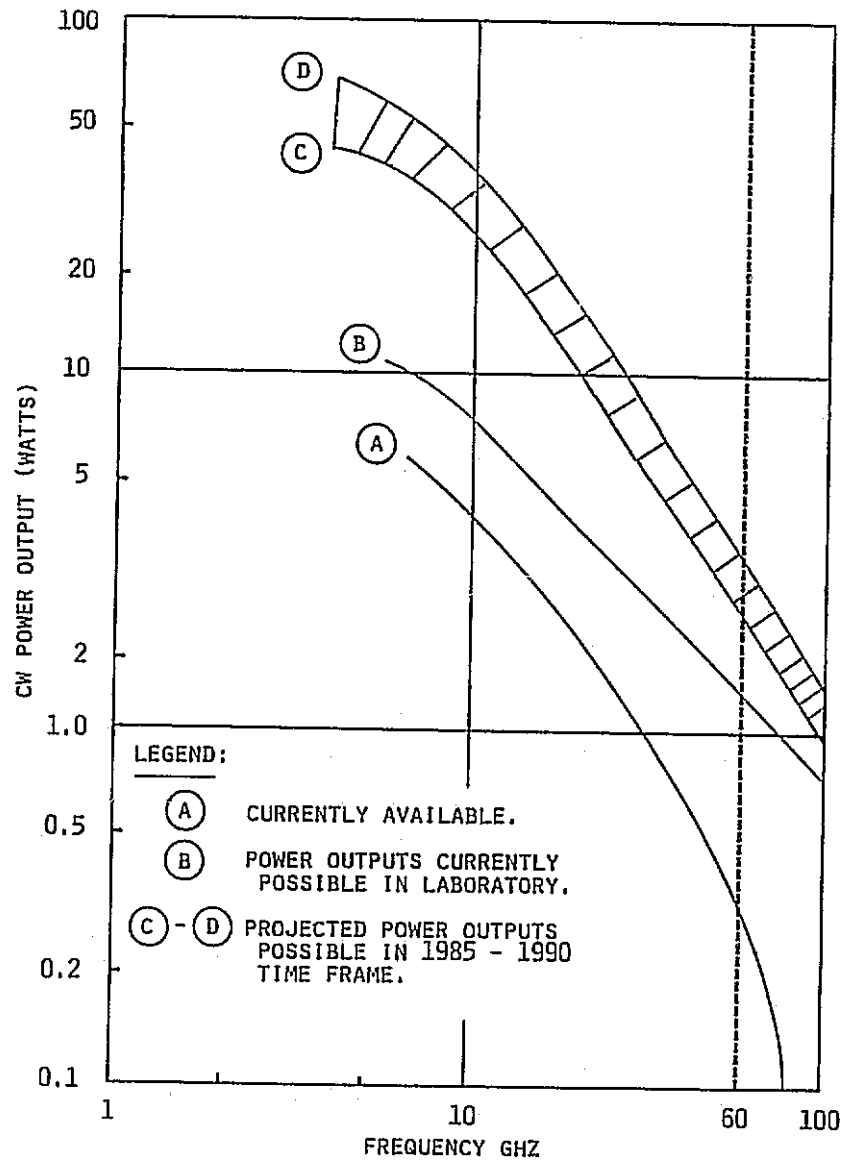

ORIGINAL PAGE IS  
OF POOR QUALITY

VII-2-29



STANFORD  
TELECOMMUNICATIONS INC.

## TECHNOLOGY ISSUES AND R&D NEEDED

This chart presents technology issues and associated R&D needed for both TWTAs and Solid State HPAs for use in the TDAS user spacecraft at the 60 GHz operational frequency. Identification of R&D needed is focused to achieve resolution of technology issues.

For satellite TWTAs, the technology issues are high unit weight and cathode design-related issues. TWT characteristics unique to the 60 GHz band require that a coupled cavity TWT design be used which, in addition to being heavier, requires a higher operating voltage. This imposes a requirement for yet to be developed power supply capabilities for spacecraft use.

The diameter of the electron beam for TWTs decreases with increase in frequency of operation. Presently, spaceborne TWTs employ oxide cathodes which, for the sake of longevity, are limited to a current density of 0.2 A/cm<sup>2</sup>. At 60 GHz, beam current densities of  $\geq 0.8$  A/cm<sup>2</sup> are required which necessitates improved cathode materials.

R&D needed for the resolution of the foregoing TWT technology issues are listed in the chart.

## TECHNOLOGY ISSUES AND R&D NEEDED

<u>COMPONENT</u>	<u>TECHNOLOGY ISSUES</u>	<u>R&amp;D NEEDED</u>
<p><u>60 GHZ HPA</u></p> <p>TYPE I: SATELLITE TWT</p>	<p><u>HEIGHT: HIGH</u></p> <p><u>CATHODE RELATED ISSUES:</u></p> <ul style="list-style-type: none"> <li>• AT 60 GHZ, SATELLITE TWT REQUIRES A COUPLED CAVITY CIRCUIT (THE OPERATING FREQ. LIMIT OF HELICAL SLOW WAVE CIRCUITS AND OXIDE CATHODES IS ~ 40 GHZ) WITH FOLLOWING IMPLICATIONS:               <ul style="list-style-type: none"> <li>- WEIGHT IS HIGH</li> <li>- OPERATING VOLTAGE IS HIGHER THAN HELIX TWT. THUS POWER SUPPLY REQUIREMENTS WILL EXCEED CURRENT SPACE PROVEN TECHNOLOGY</li> <li>- THERE IS LITTLE EXPERIENCE WITH COUPLED CAVITY TWT'S IN SATELLITES</li> <li>- AT 60 GHZ REQ'D CATHODE CURRENT DENSITY IS <math>\geq 0.8</math> A/CM<sup>2</sup> WHICH EXCEEDS THE PRESENT LIMIT OF 0.2 A/CM<sup>2</sup> FOR OXIDE CATHODES EMPLOYED IN SATELLITE TWT'S. THUS, DIFFERENT CATHODE TYPES ARE REQ'D.</li> </ul> </li> </ul>	<p>DEVELOPMENT OF LIGHT WEIGHT TWT'S</p> <p>DEVELOPMENT OF COUPLED CAVITY TWT</p> <p>DEVELOPMENT OF LIGHT WEIGHT CATHODE STRUCTURES</p> <p>DESIGN AND DEVELOPMENT OF POWER SUPPLIES SUITABLE FOR COUPLED CAVITY TWT'S</p> <p>CATHODE MATERIAL RESEARCH FOR DESIGN AND DEVELOPMENT OF IMPREGNATED OR DISPENSER TYPE CATHODES TO PROVIDE <math>&gt; 0.8</math> A/CM<sup>2</sup> CURRENT DENSITIES</p>
<p>TYPE II: SOLID STATE HPA (GAAS FET, IMPATT)</p>	<p><u>POWER OUTPUT:</u> SOLID STATE HPA'S ARE LIMITED IN THEIR OUTPUT TO NOMINALLY <math>&lt; 1</math> W. NECESSARY OUTPUT POWER MUST BE OBTAINED BY POWER COMBINING.</p> <p><u>POWER COMBINING EFFICIENCY:</u></p> <p>CURRENTLY POWER COMBINING EFFICIENCIES ARE <math>&lt; 70\%</math> CONSEQUENTLY REQUIRING MORE HPA'S TO BE COMBINED FOR ACHIEVING FINAL OUTPUT.</p>	<p>DEVELOPMENT OF RELIABLE POWER COMBINING TECHNIQUES WHICH YIELD STABLE OUTPUTS.</p> <p>DEVELOPMENT OF POWER COMBINING TECHNIQUES WITH <math>&gt; 90\%</math> COMBINING EFFICIENCY.</p>

VII-2-31



STANFORD  
TELECOMMUNICATIONS INC.

TECHNOLOGY ISSUES AND R&D NEEDED (CONTINUED)

The predominant technology issue related to solid state HPAs is the limited output power yield (< 1W) at 60 GHz, which in turn necessitates a power combiner to achieve higher power outputs. The technology issue related to the power combiner is the current power combining efficiency of 70%, which increases the number of HPAs required to be combined for a given output power. A combining efficiency of 90% and a promising combining technique are reasonable objectives of needed R&D which, when achieved, will make the use of solid state HPAs more practical.

HPA UNIQUE R&D NEEDED

Comparing the R&D needed to resolve each identified technology issue with the developments that are underway, the TDAS user spacecraft HPA unique R&D needs are listed for both viable approaches (TWT and Solid State Power Amplifier).

VII-2-34

PRECEDING PAGE BLANK NOT FILMED

HPA UNIQUE R&D NEEDED

TWTA:

- DEVELOPMENT OF ADEQUATE CATHODES
- SPACE QUALIFIABLE HIGH VOLTAGE POWER SUPPLY DEVELOPMENT
- SIMPLIFICATION OF FABRICATION TECHNIQUES
- ACCELERATE COUPLED CAVITY TWTA DEVELOPMENT

SOLID STATE HPA:

- IMPROVE POWER OUTPUT AND EFFICIENCY
- ENHANCE EFFICIENCY OF POWER COMBINERS



STANFORD  
TELECOMMUNICATIONS INC.

CONCLUSIONS

The conclusions arrived at based upon this technology assessment effort are listed.

## CONCLUSIONS

- BOTH TWTA AND SOLID STATE HPA ARE VIABLE CANDIDATES FOR TDAS USER SPACECRAFT
- SOLID STATE HPA IS POTENTIALLY MORE RELIABLE FOR S/C USE
- SOLID STATE HPA WILL REQUIRE POWER COMBINING TO SATISFY OUTPUT POWER REQUIREMENTS
- POWER COMBINER IS LIKELY TO DOMINATE OVERALL SOLID STATE HPA RELIABILITY
- LITTLE OR NO POWER COMBINING WILL BE NEEDED FOR TWTA'S

VII-2-37



STANFORD  
TELECOMMUNICATIONS INC.



2.1.1.2

USER S / C ANTENNA  
SYSTEM TECHNOLOGY

PRECEDING PAGE BLANK NOT FILMED

 STANFORD  
TELECOMMUNICATIONS INC.

USER S/C ANTENNA SYSTEM TECHNOLOGY

The initial elements of this section of the report are listed in the chart.

## USER S/C ANTENNA SYSTEM TECHNOLOGY

- REQUIREMENTS FOR TDAS USER S/C ANTENNA SYSTEM
- KEY COMPONENTS AND THEIR FUNCTIONS
- FUNCTIONAL BLOCK DIAGRAM
- EXAMPLES OF USER S/C ANTENNAS
- USER S/C DATA HANDLING SYSTEM SHOWING DEDICATED ANTENNA PROCESSOR ARCHITECTURE AND INTERFACES
- AUTOTRACKER
  - FUNCTIONAL CHARACTERISTICS
  - FUNCTIONAL BLOCK DIAGRAM
  - AUTOTRACK ANTENNA SYSTEM
  - AUTOTRACK ANTENNA AND COMBINER
  - KEY AUTOTRACKER REQUIREMENTS

VII-2-41



STANFORD  
TELECOMMUNICATIONS INC.

USER S/C ANTENNA SYSTEM TECHNOLOGY (CONTINUED)

The final elements of this section of the report are listed in the chart.

## USER S/C ANTENNA SYSTEM TECHNOLOGY

(CONTINUED)

- FACTORS AFFECTING USER S/C ANTENNA POINTING ACCURACY AND CONTROL
- ANTENNA POINTING ERROR SOURCES
- ANTENNA PERFORMANCE
- A POSSIBLE S/K<sub>U</sub>/60 GHZ BAND ANTENNA CONFIGURATION
- TECHNOLOGY ISSUES AND R&D NEEDED
- ADDITIONAL USER S/C ANTENNA UNIQUE R&D
- CONCLUSIONS

VII-2-43



STANFORD  
TELECOMMUNICATIONS INC.

## REQUIREMENTS FOR TDAS USER S/C ANTENNA SYSTEM

The antenna system requirements of a TDAS user S/C are unique to the user and for each user S/C the antenna system has to be custom tailored. However, the listed requirements are intended to be generally representative, rather than applying to any particular user or encompassing the whole TDAS user community.

Key requirement items are:

- 60 GHz operational frequency
- Pointing accuracy
- Gain losses
- Power consumption
- Antenna system weight.

REQUIREMENTS FOR TDAS USER S/C  
ANTENNA SYSTEM

<u>PARAMETER</u>	<u>REQUIREMENT</u>
TYPE	PARABOLIC
DIAMETER	NOMINALLY < 2M (DEPENDS UPON REQMTS OF INDIVIDUAL USER S/C)
DEGREES OF FREEDOM	2-AXIS, DUAL GIMBALLED
ANTENNA DRIVE	MOTOR DRIVEN GIMBALS
FREQUENCY BAND	S, KU, 60 GHZ
POLARIZATION	LINEAR/CIRCULAR
STEERING RATE	NOMINALLY .02 DEG/SEC FOR LOW ORBITS
SYSTEM BANDWIDTH	$\approx$ 2 HZ
POINTING ACCURACY	$\theta$ < 0.5 DB GAIN LOSS
ALIGNMENT	< 0.05 DEG ORTHOGONALITY BETWEEN AXES
RESOLUTION	< 0.05 DEG
DISTORTION	$\theta$ < 0.1 DB LOSS IN GAIN
SYSTEM POWER	< 10 W
SYSTEM WEIGHT	< 60 LBS

VII-2-45



STANFORD  
TELECOMMUNICATIONS INC.

KEY COMPONENTS AND THEIR FUNCTION

This chart enumerates the key components of the user spacecraft antenna system and identifies the function of each.



## KEY COMPONENTS AND THEIR FUNCTION

<u>COMPONENT</u>	<u>FUNCTION</u>
ANTENNA	TO PROVIDE HIGH GAINS REQUIRED FOR RETURN/FORWARD LINK COMMUNICATION (TO OBTAIN HIGH GAIN IT IS USUALLY PARABOLIC)
ANTENNA BOOM	ANTENNA IS SUPPORTED AT BOOM TIP TO PROVIDE UNOBSTRUCTED LINE OF SIGHT TO TDAS s/c
DEPLOYMENT/ RETRACTION MECHANISM	TO DEPLOY THE ANTENNA WHEN REQUIRED AND RETRACT IT WHEN NOT IN USE
ANTENNA POINTING AND CONTROL SYSTEM	SYSTEM TO
- ANTENNA CONTROL SYSTEM	- SLEW
- GIMBAL DRIVE ASSEMBLY	- POINT
- STEERING CONTROL ELECTRONICS	- MAINTAIN THE POINTING
- PROCESSOR	OF THE RF AXIS OF USER S/C ANTENNA AT TDAS s/c
AUTOTRACKER	ANTENNA AUTOMATIC TRACKING AID WHICH IS USED TO AUGMENT ANTENNA SYSTEM WHEN POINTING ACCURACY REQUIREMENTS ARE STRINGENT



STANFORD  
TELECOMMUNICATIONS INC.

## FUNCTIONAL BLOCK DIAGRAM

Although the user S/C antenna system is generally complex, only a simplified functional block diagram is shown in the facing chart. Since two examples of possible configurations of user S/C antennas will be shown later, this functional block diagram highlights the remaining portion of the antenna system which produces torquing signals for pointing and controlling the antenna. The following functional aspects are presented in the diagram:

- Remote Interface Unit (RIU)
- Steering Control Electronics (SCE)
- Angle Measurement System
- Torquer Drive
- Deployment Drive.

The RIU represents the interface between the antenna subsystem and other parts of the S/C. The SCE controls the position, velocity and acceleration of the gimbal axes, deployment and retraction of the deploy/retract subsystem and the thermal condition of the subsystem.

# FUNCTIONAL BLOCK DIAGRAM

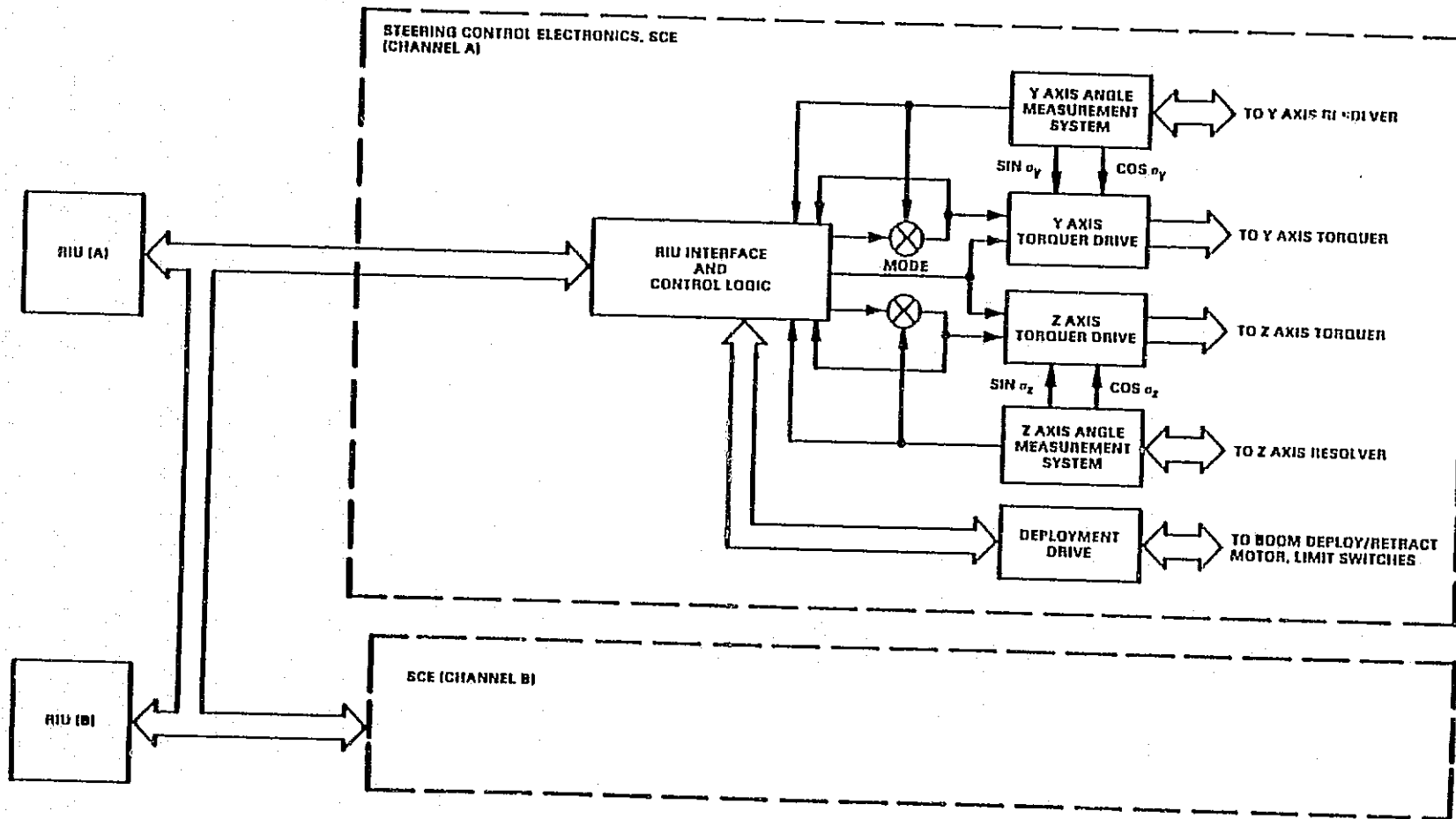

VI 2-49

ORIGINAL PAGE IS  
OF POOR QUALITY

FUNCTIONAL BLOCK DIAGRAM (CONTINUED)

The angle measurement system determines the actual angular orientation of the antenna boresight with respect to the desired orientation. The torquer drive generates necessary signals to null any pointing errors. The deployment/retraction assembly.

The remaining portions of the antenna system which are not shown in the functional block diagram consists of the following:

- Torquer
- Resolver
- Deploy/Retract motor
- Antenna boom
- Gimbals
- Antenna.

These elements are mostly electromechanical in nature; user S/C antenna examples will serve to illustrate these items.

## COORDINATE SYSTEM

The user S/C antenna is assumed to be a double gimballed antenna. The rotation axes of the two gimbals are  $\hat{Y}$  and  $\hat{Z}$  as indicated, and  $\sigma_y$  and  $\sigma_z$  are the respective gimbal rotation angles about these axes.  $\hat{X}$ ,  $\hat{Y}$ ,  $\hat{Z}$  represents the coordinate frame, and it is noted that the orientation of the  $-\hat{X}$  axis is taken to be vertically upwards but this is not necessary.

VII-2-52

PRECEDING PAGE BLANK NOT FILMED

# COORDINATE SYSTEM

- $\hat{x}$   $\hat{y}$   $\hat{z}$   $\triangle$  COORDINATE FRAME
- $\hat{y}$   $\hat{z}$   $\triangle$  ROTATION AXES OF THE TWO GIMBALS
- $\sigma_y$   $\sigma_z$   $\triangle$  GIMBAL ANGLES

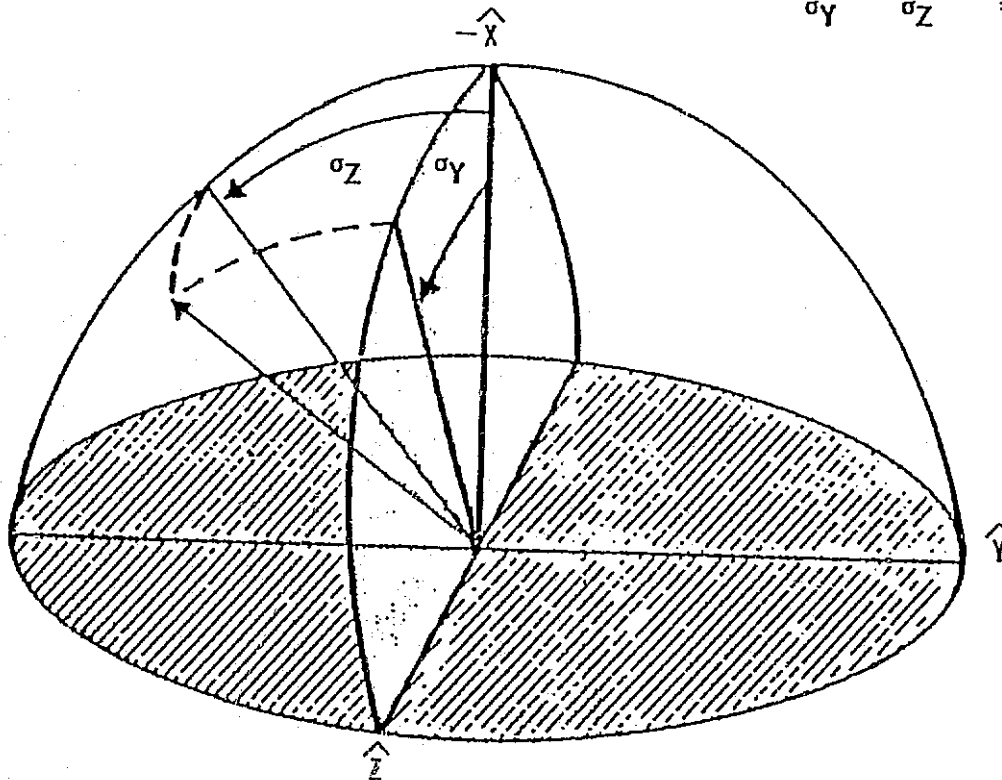

ORIGINAL PAGE IS  
OF POOR QUALITY

VII-2-53



STANFORD  
TELECOMMUNICATIONS INC.

MMS USER S/C ANTENNA EXAMPLE

The figure shows an engineering sketch of an MMS user S/C antenna. All the key components are shown in this illustration. The deploy/retract assembly is made of a collapsible structure which remains in the collapsed condition when the antenna is inoperative. This assembly is deployed to protrude from the MMS structure when communications between the user S/C and TDAS are required.

# MMS USER S/C ANTENNA EXAMPLE

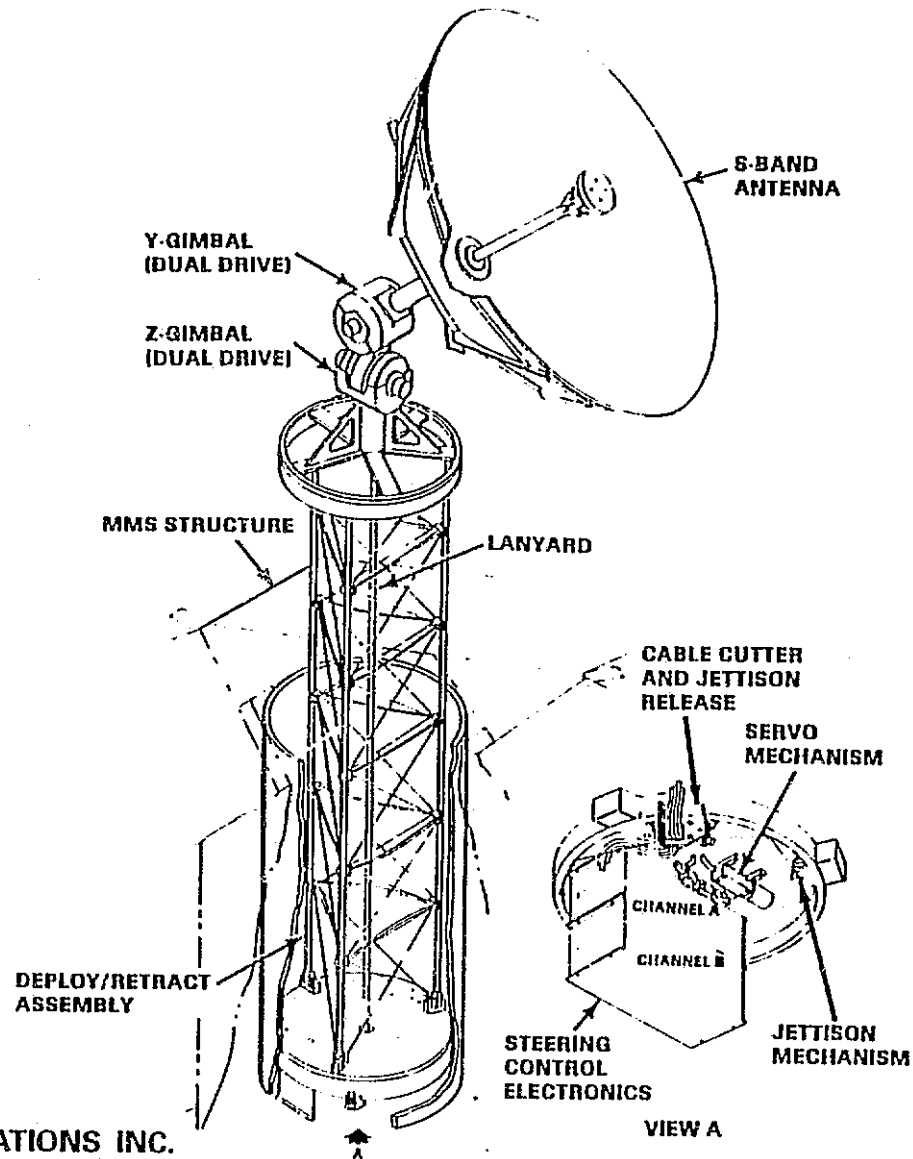

ORIGINAL PAGE IS  
OF POOR QUALITY

VII-2-55



STANFORD  
TELECOMMUNICATIONS INC.



MMS USER S/C ANTENNA CHARACTERISTICS

The characteristics of the MMS user S/C antenna are listed.

## MMS USER S/C ANTENNA CHARACTERISTICS

PARABOLIC REFLECTOR

4 FOOT DIAMETER

DOUBLE GIMBALLED

$\pm 110^\circ$  SPATIAL DEGREES RANGE

STEERING RATE LIMIT:

1.2 DEG/MIN

SLEW RATE LIMIT:

30 DEG/MIN

RETURN LINK GAIN:

27 DB (S-BAND)

DATA RATE

512 KBPS

STEERING CONTROL:

● ACCEPTS POSITION CMDS FOR EACH GIMBAL AXIS

ELECTRONICS:

● PROCESSES THE COMMANDS & GENERATES DRIVE MOTOR SIGNALS

● DRIVE MOTOR SIGNALS POINT HGAS TO COMMAND POSITION

● DIGITAL RATE LIMITING CIRCUITRY PREVENTS ANTENNA MOVEMENTS GREATER THAN STEERING/SLEW RATE LIMITS

POINTING ACCURACY:

0.64°/AXIS (BOTH FIXED AND RAMDON).

VII-2-57



STANFORD  
TELECOMMUNICATIONS INC.

### LANDSAT-D ANTENNA EXAMPLE

As a second example, the figure shows an engineering sketch of a LANDSAT-D user S/C antenna, depicting all of the components relevant to such a sketch. In this case, the antenna mast is foldable and not collapsible; a mast deployment hinge is used for this purpose. The antenna and mast are folded around this hinge when the antenna is inoperative. They are unfolded to extend the antenna to a clear position relative to the user S/C structure when communications between the user S/C and TDAS are required.

LANDSAT-D ANTENNA EXAMPLE

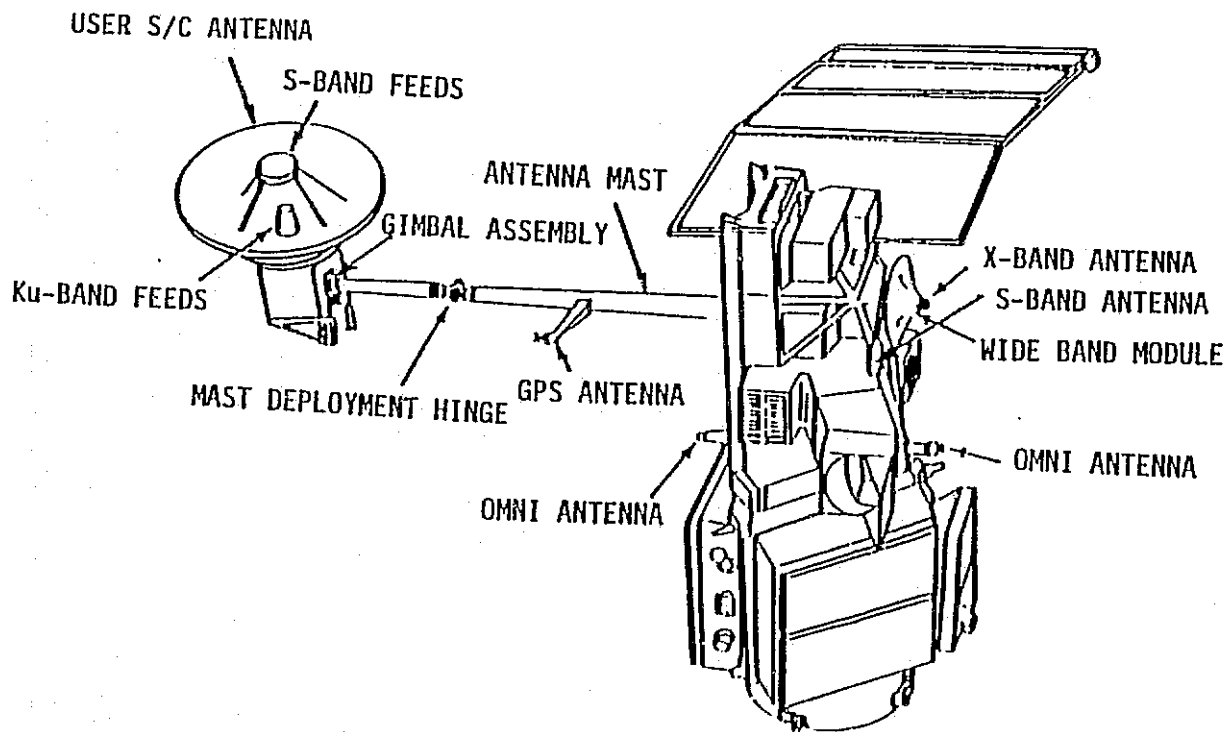

VII-2-59

ORIGINAL PAGE IS  
OF POOR QUALITY



STANFORD  
TELECOMMUNICATIONS INC.

LANDSAT ANTENNA CHARACTERISTICS

The characteristics of the LANDSAT user S/C antenna are listed.

## LANDSAT ANTENNA CHARACTERISTICS

- PARABOLIC REFLECTOR
- 6 FT. DIAMETER
- DOUBLE GIMBALLED
- $\pm 200^\circ$  AZ; -5 TO +125 ELEV. SPATIAL DEGREES RANGE
- STEERING RANGE LIMIT: 0.06 DEG/SEC
- SLEW RATE LIMIT: 2.8 DEG/SEC
- RETURN LINK GAIN 45 DB (K<sub>U</sub>-BAND)
- DATA RATE: 100 MBPS
- GIMBAL DRIVE ELECTRONICS: TO PROCESS INPUT/OUTPUT CMD/  
TELEMETRY SIGNALS FROM/TO RIU'S
- POINTING ACCURACY: . 0.09° (3- $\sigma$ ) RSS/AXIS FOR RANDOM  
ERRORS  
0.22° FIXED ERROR SOURCE EFFECTS

VII-2-61



STANFORD  
TELECOMMUNICATIONS INC.

USER S/C DATA HANDLING SYSTEM SHOWING  
DEDICATED ANTENNA PROCESSOR ARCHITECTURE AND INTERFACES

The diagram presents a simplified version of a user S/C data handling system, showing a possible architecture of the dedicated antenna processor and key interfaces. The architecture is configured upon the assumption that the antenna pointing, tracking and control functions will be performed by a dedicated processor instead of the On-Board Computer (OBC). The user S/C will probably still have an On-Board Computer to perform other spacecraft tasks and to provide user TDAS ephemeris information necessary to achieve antenna pointing.

The diagram shows the data bus through Bus Coupler Units (BCUs) and Remote Interface Units (RIUs). Another Interface Unit (IU) interfaces the antenna system and the dedicated antenna system processor to the RIU for handling antenna system telemetry and commands.

Key functions which dictate the architectural configuration are:

- Functions to be performed by the processor
- Type of processor employed
- Any specialized support hardware needed.

USER S/C DATA HANDLING SYSTEM SHOWING DEDICATED ANTENNA PROCESSOR  
ARCHITECTURE AND INTERFACES

ORIGINAL PAGE IS  
 OF POOR QUALITY

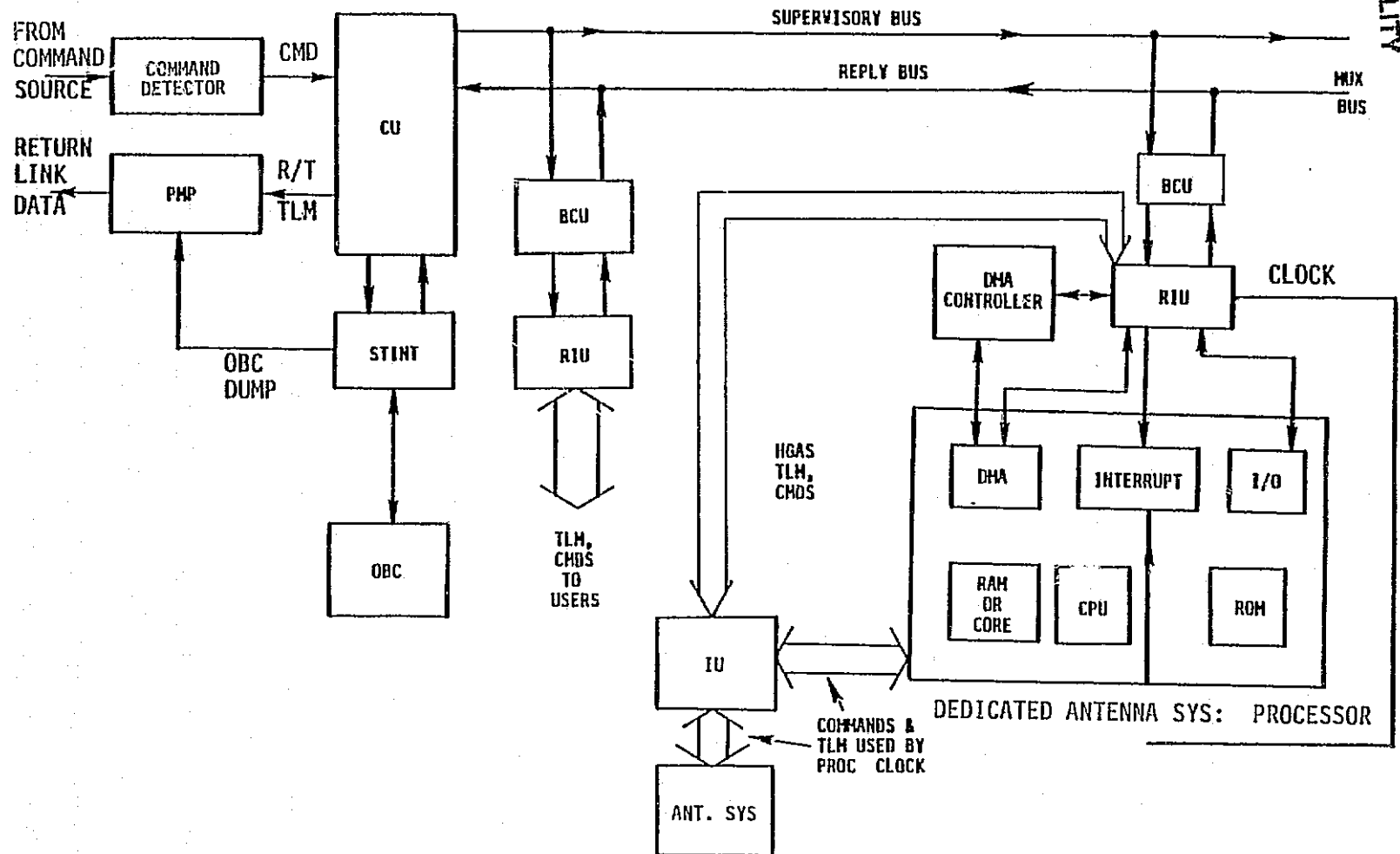

VII-2-63



USER S/C DATA HANDLING SYSTEM SHOWING  
DEDICATED ANTENNA PROCESSOR ARCHITECTURE AND INTERFACES (CONTINUED)

The Central Unit (CU) is a part of the Communications and Data Handling (C&DH) System, and all commands originating from the On-Board Computer or the Remote Interface Units. The CU formats the telemetry (the On-Board Computer can also perform this function), and the Pre-Modulation Processor (PMP) processes return link data prior to transferring it to TDAS Satellite.

The commands received by the user S/C are detected in the command detector and sent to the CU, which controls their distribution and execution. The STINT is the interface between the CU and the On-Board Computer (OBC).

## AUTOTRACKER FUNCTIONAL CHARACTERISTICS

User S/C requiring tracking accuracies greater than those can be achieved by open loop antenna pointing and control systems are augmented with an autotracker. This is an enhanced tracking aid which is activated when needed. This aid is not operational at all times but only when the pointing/tracking requirements exceed the capabilities of the antenna pointing and control system.

The chart defines the functional characteristics of an autotracker, and the following charts, respectively, show:

- Autotracker functional block diagram
- Functional block diagram of autotrack antenna system
- Autotrack antenna combiner.

VII-2-66

PRECEDING PAGE BLANK NOT FILMED

## AUTOTRACKER FUNCTIONAL CHARACTERISTICS

- SIMULTANEOUS RECEPTION/TRANSMISSION FROM/TO TDAS S, KU AND 60 GHZ FORWARD/RETURN LINK
- PROVIDE TWO-AXIS, MONOPULSE, AUTOTRACK ERROR SIGNALS FROM TDAS BEACON
- PROCESS AUTOTRACK ERROR SIGNALS AND GENERATE ANTENNA CONTROL INPUTS

VII-2-67



STANFORD  
TELECOMMUNICATIONS INC.

AUTOTRACKER FUNCTIONAL BLOCK DIAGRAM

A functional block diagram for the autotracker is shown. It illustrates the development of 2-axis antenna null error signals based upon the TDAS beacon.

# AUTOTRACKER FUNCTIONAL BLOCK DIAGRAM

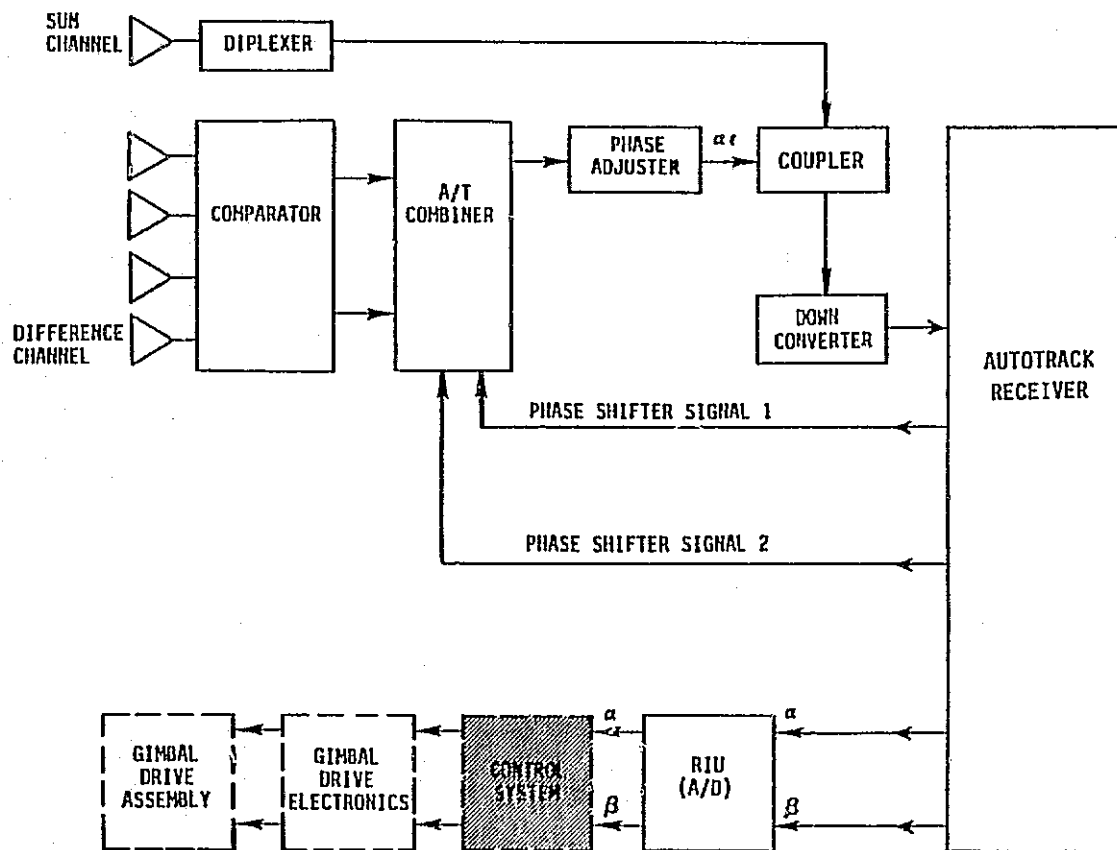

VII-2-69

ORIGINAL PAGE IS  
OF POOR QUALITY



**STANFORD  
TELECOMMUNICATIONS INC.**

FUNCTIONAL BLOCK DIAGRAM OF AUTOTRACK ANTENNA SYSTEM

A simplified block diagram of the autotrack antenna system used to develop TDAS beacon tracking error signals in azimuth and elevation is shown.

# FUNCTIONAL BLOCK DIAGRAM OF AUTOTRACK ANTENNA SYSTEM

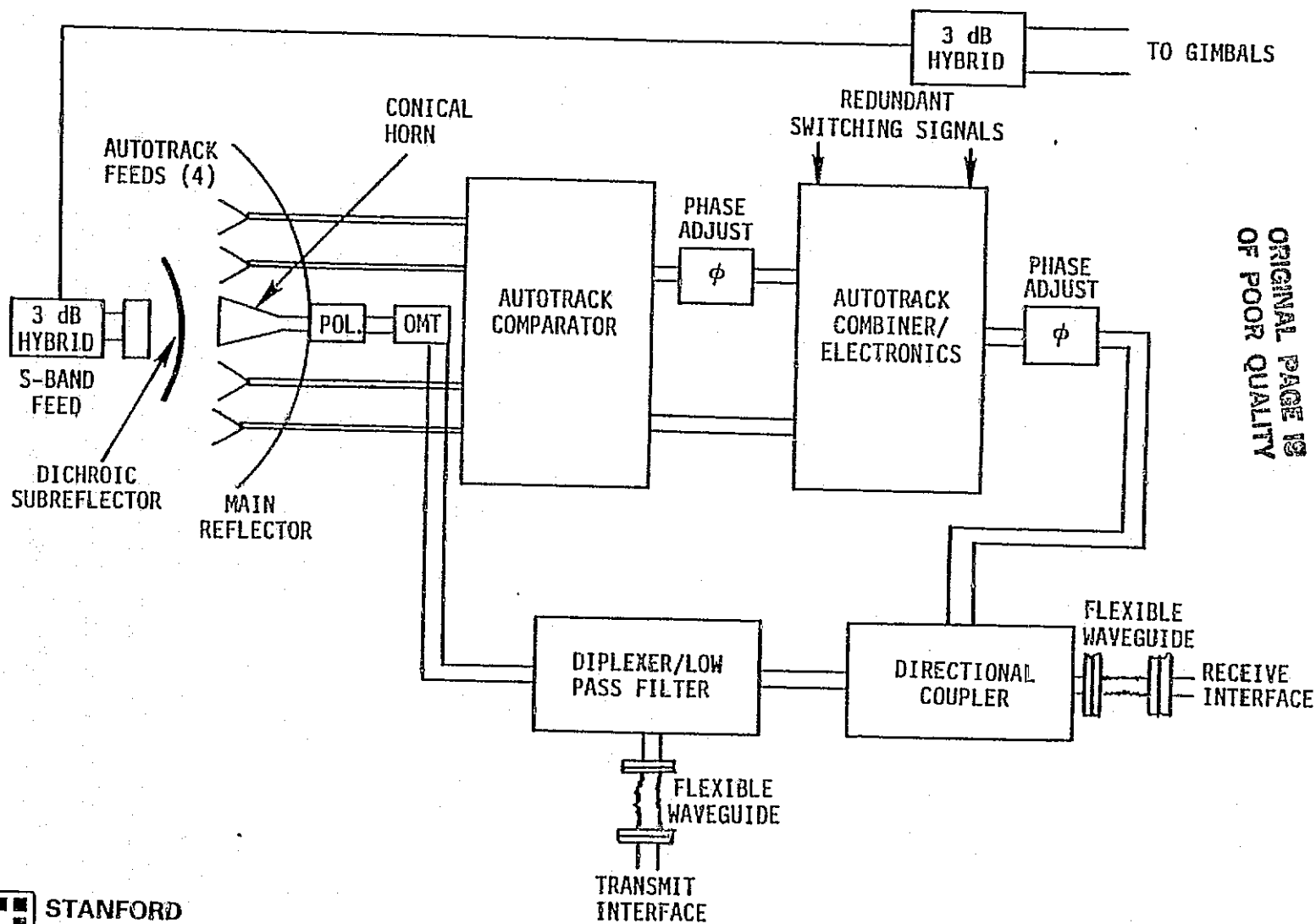

ORIGINAL PAGE IS  
OF POOR QUALITY

VII-2-71

AUTOTRACK ANTENNA AND COMBINER

Features of the autotrack antenna and combiner are shown.



# AUTOTRACK ANTENNA AND COMBINER

$$\beta = (A+B) - (C+D) = \text{AZIMUTH}$$

$$\alpha = (A+C) - (B+D) = \text{ELEVATION}$$

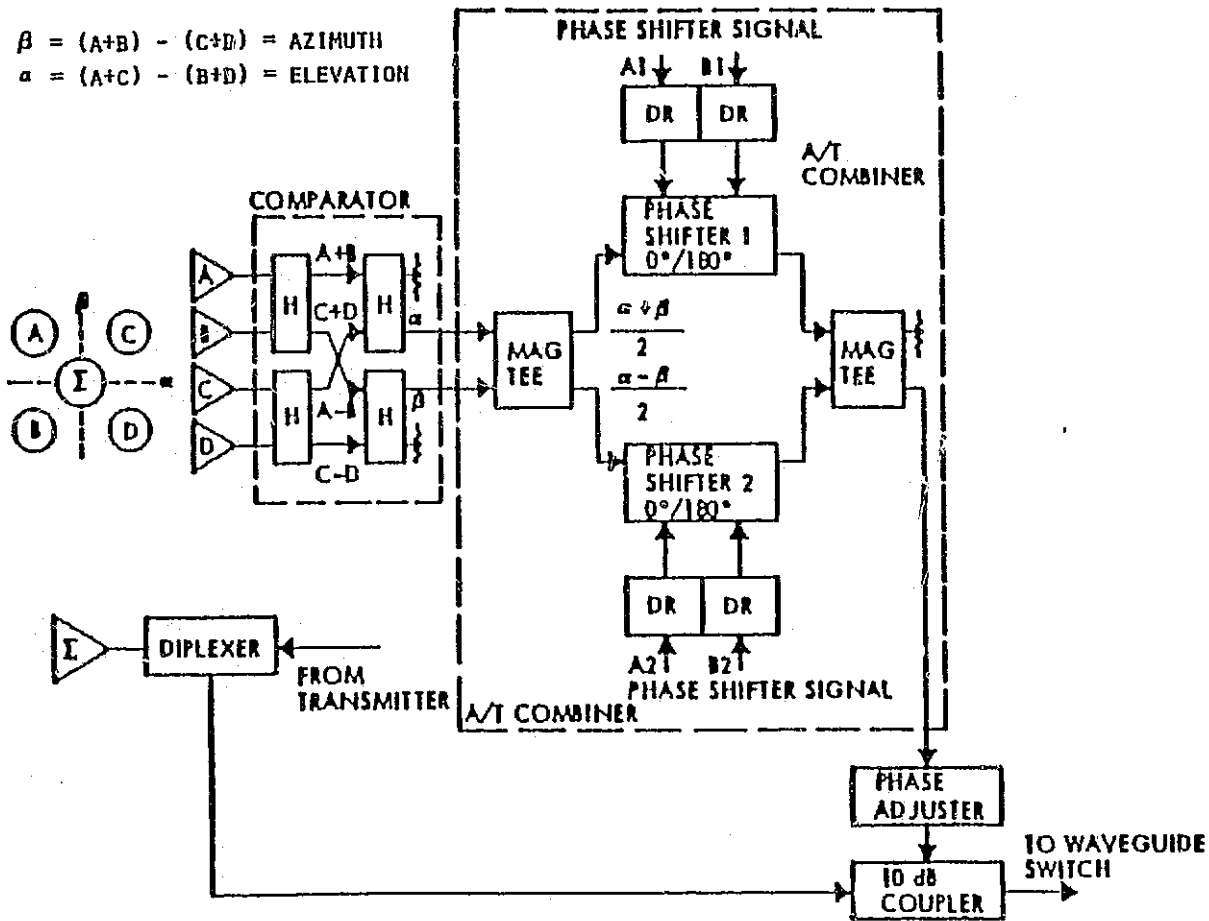

ORIGINAL PAGE IS  
OF POOR QUALITY

VII-2-73



STANFORD  
TELECOMMUNICATIONS INC.

KEY AUTOTRACKER REQUIREMENTS (NOMINAL)

The chart delineates nominal values for key autotracker requirements.

## KEY AUTOTRACKER REQUIREMENTS (NOMINAL)

<u>KEY REQUIREMENT</u>	<u>VALUE</u>
POINTING ERROR	$\alpha < 0.5$ DB GAIN LOSS
LINK PERFORMANCE	TO SATISY POINTING ERROR REQMT
TRACKING CAPABILITY	AUTOTRACK TDAS
ERROR SIGNAL SOURCE	AUTOTRACK (A/T) RECEIVER TO PROVIDE ANGLE ERROR OUTPUT SIGNALS FOR AUTOTRACKING TDAS
A/T RECEIVER IF BW	4 MHZ
ERROR SIGNAL BW	1 HZ
TDAS LINE-OF-SIGHT PULL IN RANGE	0.3 DEG WITH MIN OPERATIONAL S/N RATIO
ANGULAR TRACKING RANGE RELATIVE TO TDAS	0.1 DEG
MINIMUM S/N RATIO	SUCH THAT TRACKING ERROR IS $< 0.002$ DB
BORESIGHT ERROR	$< 0.001$ DEG
ERROR SIGNAL SENSITIVITY (SCALE FACTOR)	5V/DEG



STANFORD  
TELECOMMUNICATIONS INC.

KEY AUTOTRACKER REQUIREMENTS (CONTINUED)

The chart delineates nominal values for additional key autotracker requirements.

## KEY AUTOTRACKER REQUIREMENTS

(CONTINUED)

<u>KEY REQUIREMENT</u>	<u>VALUE</u>
ANTENNA GIMBAL ASSEMBLY AND ELECTRONICS	AUTOTRACKER SHALL BE COMPATIBLE WITH THE FOLLOWING <ul style="list-style-type: none"><li>- TWO AXIS GIMBALS</li><li>- GIMBAL DRIVE MOTORS WITH BEARINGS AND POSITION RESOLVERS</li><li>- CONTINUOUS OR STEPPER MOTORS</li><li>- CONTROL AND RESOLVER ELECTRONICS</li></ul>
GIMBAL MECHANICAL PERFORMANCE	AUTOTRACKER SHALL NOT COMPROMISE THE FOLLOWING DESIRED PERFORMANCE <ul style="list-style-type: none"><li>- ROTATION: BIDIRECTIONAL</li><li>- ELEVATION FREEDOM: 130 DEG</li><li>- AZIMUTH FREEDOM 300 DEG</li><li>- NOMINAL STEP SIZE 0.1 DEG</li><li>- STEERING RATE 0.02 DEG/SEC</li><li>- SLEW RATE</li></ul>
LIFE	> 3 YEARS

VII-2-77



STANFORD  
TELECOMMUNICATIONS INC.

## FACTORS AFFECTING USER S/C ANTENNA POINTING ACCURACY AND CONTROL

Factors affecting user S/C antenna pointing accuracy and control are identified, including whether the control loop is open or closed and the order of the control loop. The use of an autotracker enhances the operational accuracy. Within the constraints imposed by control system stability considerations, the faster the rate at which the antenna orientation is updated, the higher will be the pointing/tracking accuracy. The precision of the resolvers and the gimbals directly affect the pointing accuracy. The antenna pointing and control system design should be such that S/C platform stability is maintained as required while the control devices are applied to maintain antenna pointing.

When a user spacecraft's mission requires the use of precision instruments, the spacecraft/platform stability and associated antenna control requirements are correspondingly more stringent. In such missions, to achieve the stability and pointing accuracy requirements, the derivatives of the reaction control torques (generated by antenna torquers) on the platform must be kept within acceptable limits to limit jerks imparted to the S/C.

FACTORS AFFECTING USER S/C ANTENNA POINTING ACCURACY AND CONTROL

1. TYPE OF CONTROL LOOP: OPEN, CLOSED AND ORDER OF LOOP
2. AUTOTRACKER
3. UPDATE RATE
4. RESOLVER ACCURACY
5. GIMBAL ACCURACY
6. PLATFORM STABILITY
7. S/C PLATFORM STABILITY REQUIREMENTS

THE TIGHTER THE PLATFORM SPEC, THE MORE STRINGENT THE ANTENNA CONTROL REQUIREMENTS. MUST LIMIT MAGNITUDE OF DERIVATIVES AND THE REACTION OF CONTROL TORQUES ON PLATFORM.

VII-2-79



STANFORD  
TELECOMMUNICATIONS INC.

## ANTENNA POINTING ERROR SOURCES

Various sources of antenna pointing errors are enumerated. The antenna pointing and tracking accuracy is directly degraded by ephemeris errors for both the user and TDAS spacecraft, the resolver errors, and the errors resulting from quantizing the error signals which express the misorientations between the actual and desired pointing directions.

The distortion of the antenna reflector causes aperture illumination errors which cause beam squint and antenna gain degradation. Any fixed misalignment of the antenna when it is attached to the user spacecraft or time-varying misalignment due to the kinematic or thermal environments in the operational phase will produce pointing errors. This also relates to antenna drive alignment and any misalignments produced during deployment. The software associated with the antenna pointing and control system also causes errors due to imperfect computations.



## ANTENNA POINTING ERROR SOURCES

- FOR EACH GIMBAL AXIS:
  - USER S/C EPHEMERIS ERRORS
  - TDAS EPHEMERIS ERRORS
  - RESOLVER ERROR
  - QUANTIZATION ERRORS
  
- ANTENNA DISTORTION
  
- ANTENNA ALIGNMENT
  
- ANTENNA DRIVE ALIGNMENT
  
- MISALIGNMENTS DURING DEPLOYMENT
  
- SOFTWARE ERRORS

VII-2-81



STANFORD  
TELECOMMUNICATIONS INC.

## ANTENNA PERFORMANCE

The chart provides a tabulation of representative antenna performance data expressed in terms of gain loss for a defined pointing error and the corresponding degradation of communications capacity. This degradation is expressed as an available data rate which is a percentage of the maximum data rate, with 100% representing no errors. Performance computations are made for S, K<sub>u</sub> and 60 GHz bands with pointing errors assumed at these bands to be 1, 0.25 and 0.1 degree, respectively, for a range of antenna diameters from 2 to 10 feet. On-axis gain and 3 dB beamwidth for each case are also tabulated.

## ANTENNA PERFORMANCE

DIAMETER (FT)	ON-AXIS GAIN: DB			3-DB BEAMWIDTH: DEG			LOSS OF GAIN: DB			AVAILABLE DATA RATE (% OF MAX)		
	S	KU	60 GHZ	S	KU	60 GHZ	* S PT ER 1°	KU 0.25°	60 GHZ 0.1°	S	KU	60 GHZ
2	21	36	48	14	2.5	0.6	0.1	0.15	0.4	98	97	86
4	27	42	54	7	1.25	0.3	0.25	0.5	1.4	94	88	95
6	31	46	58	4.7	0.8	0.2	0.5	1.2	3.0	88	76	50
8	33	48	60	3.5	0.6	0.15	1.0	2.0	5.5	79	62	30
10	35	50	62	2.8	0.5	0.13	1.5	3.0	8.5	70	50	15

\* PT ER - POINTING ERROR

ORIGINAL PAGE IS  
OF POOR QUALITY

VII-2-83



**STANFORD  
TELECOMMUNICATIONS INC.**

## POSSIBLE S/Ku/60 GHZ BAND ANTENNA CONFIGURATION

Key characteristics of a possible conceptual configuration of a multiband user S/C antenna system are listed in the chart. The configuration assumes:

- Cassegrain type antenna for  $K_u$ /60 GHz bands
- Front-fed antenna for S-band
- Dielectric subreflector
- 60 GHz feed accommodated within  $K_u$  band feed
- Autotracker augmentation at 60 GHz and  $K_u$  bands.

This conceptual configuration should serve as a starting point to conduct design feasibility efforts to evolve adequate antenna designs for operation at 60 GHz/ $K_u$  bands or other multiple bands selected out of S,  $K_u$  and 60 GHz bands.

Almost invariably a single band user S/C antenna will be needed. It is unlikely that multiple band user S/C antenna will be required.

## A POSSIBLE S/K<sub>U</sub>/60 GHZ BAND ANTENNA CONFIGURATION

<u>CHARACTERISTIC</u>	<u>60 GHZ</u>	<u>K<sub>U</sub>-BAND</u>	<u>S-BAND</u>
ANTENNA ILLUMINATION	CASSEGRAIN	CASSEGRAIN	FRONT FED
MAIN REFLECTOR	GOLD/COPPER PLATED GRAPHITE	GOLD/COPPER PLATED GRAPHITE	K <sub>U</sub> /60 GHZ BANDS DICTATE PERFORMANCE WHICH WILL EXCEED REQMTS
REFLECTOR	DICHROIC	DICHROIC	TRANSPARENT
FEED			
- TRANSMIT	60 GHZ HORN WITHIN K <sub>U</sub> BAND HORN	SAME	DIPOLAS
- RECEIVE	60 GHZ HORN WITHIN K <sub>U</sub> -BAND FOUR ERROR HORNS	SAME	DIPOLAS
AUTOTRACK	MONOPULSE COM- PARATOR AND COMBINER	SAME	PROBABLY NOT REQUIRED

VII-2-85



STANFORD  
TELECOMMUNICATIONS INC.

## TECHNOLOGY ISSUES AND R&D NEEDED

Technology issues which resulted from this technology assessment effort are listed in the chart, along with the R&D efforts needed to resolve these issues. Identification of technology issues and R&D needed is broken down on the basis of the following components of the antenna system: 1) Antenna, 2) Antenna Boom, 3) Deployment/Retraction, 4) Antenna Pointing and Control System (APCS), and 5) Autotracker.

The technology issues for the antenna are related to its gain, pointing accuracy and 60 GHz band operational capability. The goal of the needed R&D should be to achieve a reflector surface roughness of approximately 0.1 mm and high structural rigidity. In addition, design feasibility efforts should be conducted to develop feed subsystems with the indicated 60 GHz frequency band operational capability.

In order to limit antenna vibrations (due to flexibility of the antenna boom) with consequent pointing errors, the key issue for the antenna boom is that it should be simultaneously light in weight and high in structural rigidity. The R&D efforts should aim to identify promising boom configuration and to practically demonstrate its performance in a zero environment.

The common problem with deployment/retraction mechanisms is their failure to deploy and/or retract properly. The necessary R&D efforts should achieve the objectives of defining possible failure modes and of developing adequate mechanisms with approximately a 5-year lifetime. This lifetime should be greater than the life of the user S/C to assure failure-free deployment and retraction of the antenna during the mission.

## TECHNOLOGY ISSUES AND R&D NEEDED

<u>COMPONENT</u>	<u>TECHNOLOGY ISSUE</u>	<u>R&amp;D NEEDED</u>
ANTENNA *	<ul style="list-style-type: none"><li>● GAIN, EFFICIENCY AND POINTING ACCURACY DECREASES WITH<ul style="list-style-type: none"><li>- SURFACE ROUGHNESS OF REFLECTOR</li><li>- REFLECTOR DEFORMATION DUE TO REFLECTOR AND STRUCTURE FLEXIBILITY</li></ul></li></ul> <p>DEGRADATIONS INCREASE WITH FREQUENCY</p> <ul style="list-style-type: none"><li>● OPERATIONAL ABILITY OF ANTENNA OVER MULTIPLE FREQ. BANDS (IF DESIRED IN A PARTICULAR CASE)</li></ul>	<ul style="list-style-type: none"><li>● AN ANTENNA WITH <math>\sim 0.1</math> MM REFLECTOR SURFACE ROUGHNESS AND HIGHLY RIGID FROM STRUCTURAL VIEWPOINT SHOULD BE DESIGNED AND DEVELOPED FOR OPERATION AT 60 GHZ</li><li>● DEVELOPMENT OF PHASED ARRAY ANTENNAS WITH ONE 60 GHZ HPA UNIT FOR EACH ELEMENT</li><li>● INVESTIGATE THE POSSIBILITY OF DESIGNING FEED SUBSYSTEMS WHICH CAN OPERATE AT TWO OR MORE OF S, K<sub>U</sub> AND 60 GHZ BANDS</li></ul>
ANTENNA BOOM	<ul style="list-style-type: none"><li>● DESIRABILITY OF LIGHT WEIGHT, RIGID AND COLLAPSIBLE/TELESCOPIC BOOMS PRESENT CONFLICTING REQUIREMENTS</li></ul>	<ul style="list-style-type: none"><li>● VARIOUS DESIGN CONFIGURATIONS ARE POSSIBLE. THESE SHOULD BE COMPARATIVELY EVALUATED BY ANALYTICAL/SIMULATION TECHNIQUES AND PROMISING CONFIGURATIONS BE PRACTICALLY TESTED IN ZERO G ENVIRONMENT</li></ul>
DEPLOYMENT/RETRACTION	<ul style="list-style-type: none"><li>● DOMINANT PROBLEM IS THE FAILURE OF THE MECHANISM TO DEPLOY AND/OR</li></ul>	<ul style="list-style-type: none"><li>● INVESTIGATE FAILURE MECHANISMS, THEIR UNDERLYING CAUSES AND CANDIDATE SOLUTIONS FOR A USER S/C LIFE OF <math>\sim 5</math> YEARS</li></ul>

\*60 GHZ ARRAY ANTENNAS WITH ONE HPA UNIT FOR EACH ELEMENT OF THE ARRAY ARE STRONG CONTENDERS TO REFLECTOR ANTENNAS AND ARE DISCUSSED IN HPA SECTION 2.1.1.



STANFORD  
TELECOMMUNICATIONS INC.

TECHNOLOGY ISSUES AND R&D NEEDED (CONTINUED)

Various technology issues are related to the APCS. In the operational phase, when control torques for pointing purposes are important to the antenna, torque noise is reacted back to the S/C. Consequently, the S/C jerks and it experiences attitude disturbances. To resolve this problem, the APCS and the user S/C attitude control system should not be individually designed. Instead, they should be jointly and concurrently designed by appropriately addressing flexibility effects and torque noise. A developed model of an APCS for 60 GHz operation is completely lacking. It is, therefore, necessary that adequate development activities be initiated, with an emphasis on realizing the desired capabilities of operation with high accuracy at 60 GHz. To achieve this without disturbing the user S/C attitude, Kalman filters should be used to augment the user S/C attitude control system which will improve the quality of attitude determination and correction by estimating gyro drifts.



## TECHNOLOGY ISSUES AND R&D NEEDED

(CONTINUED)

<u>COMPONENT</u>	<u>TECHNOLOGY ISSUE</u>	<u>R&amp;D NEEDED</u>
ANTENNA POINTING & CONTROL SYSTEM (APCS)	<ul style="list-style-type: none"><li>● TORQUES IMPARTED TO POINT THE ANTENNA CAUSE<ul style="list-style-type: none"><li>- TORQUE NOISE</li><li>- S/C JERKS</li></ul>WHICH DISTURBS SATELLITE BORNE INSTRUMENTS AND DEGRADES DATA RATE PERFORMANCE</li><li>● NO APCS HAS BEEN DEVELOPED FOR 60 GHZ OPERATION WHERE STRINGENT POINTING ACCURACIES ARE AN ISSUE</li><li>● INADEQUACIES IN THE DESIGN AND MACHINING OF MECHANICAL PARTS DEGRADE PERFORMANCE</li></ul>	<ul style="list-style-type: none"><li>● METHODS SHOULD BE DEVELOPED TO JOINTLY CONFIGURE AND OPTIMIZE ANTENNA CONTROL SYSTEM AND USER S/C ATTITUDE CONTROL SYSTEM ACCOUNTING FOR FLEXIBILITY EFFECTS AND TORQUE NOISE</li><li>● STRINGENT POINTING ACCURACY REQMS SHOULD DICTATE NECESSARY DEVELOPMENT OF 60 GHZ APCS IN WHICH<ul style="list-style-type: none"><li>- ANTENNA CONTROL SYSTEM HAS TO BE MORE FREQUENTLY ACTIVATED TO IMPART CORRECTIVE POINTING TORQUES</li><li>- EXTENDED KALMAN FILTER IS IMPLEMENTED TO ENHANCE ATTITUDE MEASUREMENT ACCURACY OF USER S/C ACS BY ESTIMATING GYRO DRIFT ALONG WITH ATTITUDE</li></ul></li><li>● IT IS NECESSARY TO ENHANCE MACHINING PRECISION AND LONG WEARING BEARINGS</li><li>● DEVELOPMENT OF MAGNETICALLY SUSPENDED BEARINGS.</li></ul>



STANFORD  
TELECOMMUNICATIONS INC.

TECHNOLOGY ISSUES AND R&D NEEDED (CONTINUED)

Additional technology issues related to the APCS hardware are design inadequacies of mechanical parts, wear and tear of bearings, optimum gimbal drive motors and the weight/power burden of Steering Control Electronics (SCE). The needed R&D should seek to enhance the life and precision of bearings to identify if a "continuous" or "stepper" motor should be used in the 60 GHz APCS, and to develop a lightweight/low power consumption SCE assembly. Continuous drive motor is the way to go in general, but in particular cases, stepper can be used.

A processor which performs the computations necessary to point the antenna must be associated with the APCS. Two choices for this are the use of the user S/C On-Board Computer (OBC) or a Dedicated Processor. In addition to the advantages stated on the chart, a dedicated processor-based APCS allows the antenna system to be tested earlier in the design phase than if the APCS utilizes a central On-Board Computer. A dedicated processor thus appears necessary or highly desirable, and a representative design must be implemented and its performance demonstrated through R&D efforts.

## TECHNOLOGY ISSUES AND R&D NEEDED

(CONTINUED)

<u>COMPONENT</u>	<u>TECHNOLOGY ISSUE</u>	<u>R&amp;D NEEDED</u>
ANTENNA POINTING & CONTROL SYSTEM (APCS) (CONTINUED)	<ul style="list-style-type: none"><li>● POINTING ACCURACY DETERIORATES WITH WEAR &amp; TEAR OF BEARINGS</li><li>● IT IS NOT CLEAR WHETHER "CONTINUOUS" OR "STEPPER" TYPE MOTORS SHOULD BE USED IN GIMBAL DRIVES FOR 60 GHZ SYSTEMS</li><li>● STEERING CONTROL ELECTRONICS PUTS WEIGHT AND POWER BURDEN ON TDAS USER S/C</li><li>● DUE TO<ul style="list-style-type: none"><li>- INCREASED DEMANDS ON THE CENTRAL ON-BOARD COMPUTER IN THE FUTURE</li><li>- INCREASED COMPUTATIONAL DEMANDS PLACED BY W-BAND APCS DUE TO HIGHER UPDATE NECESSARY TO YIELD DESIRED POINTING ACCURACY</li><li>- POSSIBILITY OF CENTRAL OBC BEING TIED UP WHEN AN UPDATE IS NEEDED</li></ul></li></ul>	<ul style="list-style-type: none"><li>● STUDY IS NECESSARY TO IDENTIFY OPTIMUM CHOICE</li><li>● SMALL, LIGHT WEIGHT AND LOW POWER CONSUMPTION STEERING CONTROL ELECTRONICS SUBSYSTEM SHOULD BE DEVELOPED TO REDUCE WEIGHT/POWER BURDEN ON USER S/C</li><li>● A DEDICATED PROCESSOR IS NECESSARY AND A REPRESENTATIVE DESIGN BASED ON STATE OF ART MICROPROCESSOR BE DEVELOPED, ITS NECESSARY INTERFACES WITH CENTRAL ON-BOARD COMPUTER IDENTIFIED AND PERFORMANCE DEMONSTRATED</li></ul>

VII-2-91



STANFORD  
TELECOMMUNICATIONS INC.

TECHNOLOGY ISSUES AND NEEDED R&D (CONTINUED)

Autotrackers have been developed\* during the LANDSAT and TDRS Spacecraft development phases, but, for the particular case of user S/C using TDAS, the autotracking must operate at 60 GHz. This is a band for which no autotracker has been developed. This represents the source of the technology issues listed on the chart. Necessary R&D efforts to resolve these technology issues are identified.

---

\* These autotrackers are meant to operate at  $K_u$  band and even at this band, all the autotracker problems are not solved. It is very sensitive to signal changes and signal variations can be interpreted as tracking inaccuracy. At 60 GHz, we are far from being done.

## TECHNOLOGY ISSUES AND R&D NEEDED

(CONTINUED)

### COMPONENT

AUTOTRACKER

### TECHNOLOGY ISSUE

- REQUIRED CAPABILITY TO HANDLE THREE (3) FREQ. BANDS, S, KU, & 60 GHZ COMPLICATE ANTENNA SYSTEM DESIGN
- AT 60 GHZ, TIGHT MECHANICAL PRECISION AND STRINGENT POSITIONAL ACCURACIES ARE REQUIRED TO ACHIEVE DESIRED TRACKING ACCURACY
- APERTURE ILLUMINATION ERRORS INDUCED IN MAIN REF., SUB REF. AND FEED APERTURES DEGRADE POINTING/TRACKING ACCURACY
- SENSING RF BORESIGHT SHIFTS BASED ON AMPLITUDE MONOPULSE TECHNIQUES PROVIDE SUBOPTIMUM TRACKING ACCURACIES

### R&D NEEDED

- ANTENNA CONFIGURATION STUDY WITH SPECIAL EMPHASIS ON COMMUNICATION AND TRACKING FEEDS IS NECESSARY TO IDENTIFY OPTIMUM DESIGN
- DEMONSTRATION MODEL SHOULD BE DESIGNED USING PRECISION MACHINING AND FABRICATION TECHNIQUES
- MATERIAL, CONSTRUCTION AND FABRICATION TECHNIQUES OF ANTENNA COMPONENTS SHOULD BE INVESTIGATED AND OPTIMUM METHODOLOGY THAT RESULTS IN A LEAST FLEXIBLE SYSTEM WHICH IS HIGHLY IMMUNE TO ERRORS IN OPERATIONAL PHASE SHOULD BE IDENTIFIED
- INITIATION OF A STUDY TO IDENTIFY SENSITIVE, NOISE IMMUNE AND OPTIMALLY ACCURATE SENSING TECHNIQUES

VII-2-93



STANFORD  
TELECOMMUNICATIONS INC.

### ADDITIONAL USER S/C ANTENNA UNIQUE R&D

Based upon the experience built up in the past and the current ongoing development activities, the additional user S/C antenna unique R&D needed is listed on the chart.

- The existence of cross-fertilization of TDAS S/C technology by user S/C technology (and vice versa) does not imply the elimination of technology R&D effort for achieving enabling technologies for the subsystems of one by virtue of cross-fertilization and technology R&D effort done for the other. Although cross-fertilization is beneficial, still unique R&D is necessary for each individual case. For the case of user S/C antenna in particular, TDAS technology R&D unique to WSA antennas will be helpful but will not be able to replace technology R&D unique to user S/C antenna. This is due to difference in requirements and points of difference between user S/C antennas and WSA antennas. To mention a few, compared with WSA antennas, the volumetric gain (volume over which acceptable gain is realized) reliability, life and redundancy of user S/C antennas is low.

User should not be forgotten and a parallel technology R&D for user S/C antenna must be done.

## ADDITIONAL USER S/C ANTENNA UNIQUE R&D

### CONDUCT:

- INVESTIGATION OF MATERIALS, FABRICATION AND ASSEMBLY TECHNIQUES YIELD LIGHT WEIGHT AND SMOOTH ANTENNA
- DEVELOPMENT OF LIGHT WEIGHT, S, KU, 60 GHZ FEED STRUCTURES
- SIMULATION (EXPERIMENTAL AND/OR COMPUTER) TO IDENTIFY
  - OPTIMUM CONTROL CONFIGURATION
  - ADEQUATE CONTROL LAW
  - SUITABLE TYPE OF GIMBAL DRIVE MOTORS
  - STRUCTURAL FLEXIBILITY EFFECTS
  - FACTORS INFLUENCING TORQUE NOISE

TO SERVE AS GUIDELINES FOR USER S/C ANTENNA DESIGN

- DEVELOPMENT OF A MICROPROCESSOR BASED DEDICATED PROCESSOR FOR ANTENNA POINTING AND CONTROL
- DESIGN AND DEVELOPMENT OF AUTOTRACKER FOR 60 GHZ APPLICATIONS
- DEVELOPMENT OF PHASED ARRAY ANTENNAS WITH ONE 60 GHZ HPA UNIT FOR EACH ELEMENT OF THE ARRAY



STANFORD  
TELECOMMUNICATIONS INC.

## CONCLUSIONS

Based upon this technology assessment effort, the resulting conclusions are listed.



## CONCLUSIONS

- 60 GHZ USER S/C — TDAS LINKS HAVE HIGH DATA RATE CAPABILITY
- NO USER S/C ANTENNA HAS EVER BEEN BUILT FOR 60 GHZ OPERATION — A MISSING PART OF THE LINK
- TO EXPLOIT HIGH RATE CAPABILITY, R&D MUST BE DONE TO DEVELOP USER S/C ANTENNA SYSTEM WHICH CAN WORK AT  $K_U$  AND 60 GHZ BANDS
- AUTOTRACKER MUST AUGMENT USER S/C ANTENNA SYSTEM
- WE CAN MAKE USER S/C BETTER BECAUSE
  - USER S/C TECHNOLOGY R&D WILL CONTINUE EVEN AFTER TDAS S/C IS DEPLOYED
  - USER S/C TECHNOLOGY R&D IS LESS EXPENSIVE
- CROSS FERTILIZATION BETWEEN TDAS USER S/C AND TDAS S/C ALTHOUGH BENEFICIAL DOES NOT IMPLY THAT TDAS USER S/C R&D WILL ELIMINATE THE NEED FOR TDAS S/C R&D OR VICE VERSA
- IN TECHNOLOGY R&D EFFORT THERE DOES NOT SEEM TO BE ANY SIGNIFICANT RISK TO MEET GOALS



STANFORD  
TELECOMMUNICATIONS INC.

2.1.3

ON - BOARD TAPE RECORDER  
TECHNOLOGY

PRECEDING PAGE BLANK NOT FILMED

 STANFORD  
TELECOMMUNICATIONS INC.

ON-BOARD TAPE RECORDER TECHNOLOGY

The various elements of this section of the report are listed in the chart.

## ON-BOARD TAPE RECORDER TECHNOLOGY

- REQUIREMENTS OF TDAS USER S/C
- KEY PARAMETERS AND INFLUENCING FACTORS
- CURRENT AND PROJECTED CAPABILITIES
- TECHNOLOGY ISSUES AND R&D NEEDED
- ON-BOARD TAPE RECORDER UNIQUE R&D NEEDED
- CONCLUSIONS

VII-2-101



STANFORD  
TELECOMMUNICATIONS INC.

ON-BOARD TAPE RECORDER REQUIREMENTS OF TDAS USER S/C

Key requirements, as they apply to the On-Board Tape Recorders of a TDAS user S/C are listed. Since each user S/C will have unique requirements depending upon its mission, the requirements are meant to be generally representative and not for any specific user S/C. In addition, these requirements apply only to NASA users', DoD users are not included.

REQUIREMENTS OF TDAS USER S/C

STORAGE	$\geq 10^{12}$ BITS
RECORD RATE	$\approx 300$ MBPS
REPRODUCE RATE	$\approx 300$ MBPS
WEIGHT/POWER BURDEN	$\approx$ HALF OF WHAT IS POSSIBLE WITH CURRENT TECHNOLOGY

VII-2-103



STANFORD  
TELECOMMUNICATIONS INC.

## KEY PARAMETERS AND INFLUENCING FACTORS

The chart lists the key parameters of On-Board Tape Recorders in terms of what can be achieved relative to requirements and the factors that influence these parameters and consequently the tape recorder capabilities.

Tape utilization efficiency is important for achieving high storage capacities. Further, the storage capacity increases with tape width, number of tracks and number of transport units. In order to achieve high (> 50 Mbps) record/reproduce speeds, in addition to high tape speeds, appropriate recording codes to enhance throughput and error correcting capabilities have to be used. To maintain a useable bit error rate at high speeds (which requires an increased number of data tracks and per-track packing densities) an error correction scheme becomes a necessity.

At high speeds, tape-head characteristics (particularly the friction between tape head and tape) become important. The weight/power characteristics depend upon the number of transport units (TU) and electronics units (EU) and the electronics technology employed.

## KEY PARAMETERS AND INFLUENCING FACTORS

### PARAMETER

### INFLUENCING FACTORS

TAPE UTILIZATION  
EFFICIENCY:

INCREASES WITH:

- INCREASE IN NUMBER OF DATA TRACKS
- REDUCTION IN TRACK WIDTH
- PER TRACK RECORDING DENSITY
- ADDITION OF EFFICIENT ERROR CONTROL SYSTEM

STORAGE CAPACITY:

INCREASES WITH:

- TAPE WIDTH
- TAPE UTILIZATION EFFICIENCY
- NUMBER OF TRACKS
- NUMBER OF TRANSPORT UNITS

RECORD/REPRODUCE  
SPEED:

DEPENDS ON:

- TAPE HEAD CHARACTERISTICS
- RECORDING CODE
- ERROR CORRECTING CODE
- TAPE SPEED

WEIGHT/POWER:

DEPENDS ON:

- NUMBER OF TRANSPORT UNITS
- NUMBER OF ELECTRONICS UNITS
- ELECTRONICS TECHNOLOGY EMPLOYED



STANFORD  
TELECOMMUNICATIONS INC.



## CURRENT AND PROJECTED CAPABILITIES

The table depicts a representative profile of the characteristics of the On-Board Tape Recorders of the 1980's. All of the key characteristics are addressed.

For tape recorders with record rates  $\geq$  50 Mbps, development efforts are required before such units can become operational.

## CURRENT AND PROJECTED CAPABILITIES

NUMBER	TOTAL STORAGE (BITS)	RECORD RATES (MBPS)	RECORD SPEEDS (IPS)	TAPE LENGTH (FT)	REPRODUCE RATES (MBPS)	REPRODUCE SPEEDS (IPS)	BIT ERROR RATE	WEIGHT (LBS)	POWER RECORD REPRODUCE (W)
1	1.7x10 <sup>9</sup>	.066/ .666/1.3	1/10/20	2100	1.3/2.6	20/40	10 <sup>-6</sup>	20	8/9/10 41/44
2	4x10 <sup>9</sup>	.006-8	.73-120	2400	.006-8	.73-120	10 <sup>-6</sup>	37	30 40
3	5x10 <sup>9</sup>	1-20	4.8-96	2100	2-20	9.6-96	10 <sup>-6</sup>	30	45 60
4	10 <sup>10</sup>	1-25	2.8-70	2400	2.5-25	5.6-70	10 <sup>-6</sup>	43	60 75
5	3.8x10 <sup>10</sup>	1-32	2.9-92	9200	2-32	5.6-89	10 <sup>-6</sup>	105	65/85 153/173
6*	7.5x10 <sup>10</sup>	50	75	9200	50	75	10 <sup>-6</sup>	157	150
7*	7.5x10 <sup>10</sup>	50-125	75-188	9200	50-125	75-188	10 <sup>-6</sup>	157	190-250 280-380
8*	3.6x10 <sup>11</sup>	85-300	-	3000	85-300	-	10 <sup>-6</sup>	~157	~200 ~300

\* NEED FURTHER DEVELOPMENT

ORIGINAL PAGE IS  
OF POOR QUALITY



**STANFORD  
TELECOMMUNICATIONS INC.**

EXPECTED CAPABILITIES OF ON-BOARD TAPE RECORDERS  
IN 1985-1990 TIME FRAME

Based upon the current state of art, on-going development activities and engineering judgements, the expected capabilities of On-Board Tape Recorders in the 1985-1990 time frame are listed. In assessing the expected capabilities, it has been assumed that adequate levels of development activities will be maintained, which will include a Record/Reproduce rate objective of up to 1 Gbps.

EXPECTED CAPABILITIES OF  
ON-BOARD TAPE RECORDERS IN 1985-1990 TIME FRAME

STORAGE  $10^{12}$  -  $10^{13}$  BITS

RECORD RATE 0.3 - 1 GBPS

REPRODUCE RATE 0.3 - 1 GBPS

WEIGHT/POWER BURDEN  
POTENTIALLY HALF OF WHAT IS  
CURRENTLY REQD FOR SAME  
PERFORMANCE TODAY

VII-2-109



STANFORD  
TELECOMMUNICATIONS INC.

## TECHNOLOGY ISSUES AND R&D NEEDED

The chart presents technology issues and associated R&D needed to resolve these issues as they pertain to On-Board Tape recorders in the 1985-1990 time frame.

The key technology issues are:

- Storage
- Speed.

A reduction in track width causes the storage capacity to increase, for which a price in terms of precise servo controlled tracking has to be paid. As the record/reproduce speed increases above approximately 15 Mbps, the technology issues that arise are:

- Increase in tape transport speed
- Need for a fast-response Electronics Unit
- Increase in
  - Channel related electronics
  - Power consumption
  - Cost
  - Complexity.

At extremely high speeds ( $\approx 1$  Gbps), the recording head design has to be changed.

R&D efforts needed to resolve the technology issues are identified.

## TECHNOLOGY ISSUES AND R&D NEEDED

### COMPONENT

ON-BOARD  
TAPE RECORDER

### TECHNOLOGY ISSUES

STORAGE: HIGHER GAINS IN STORAGE CAPACITY ACCRUE FROM REDUCED TRACK WIDTHS THAN INCREASED PACKING DENSITIES. THIS REQUIRES PRECISE SERVO CONTROLLED TRACKING.

SPEED: AS THE SPEED INCREASES ABOVE 2 15 MBPS FOLLOWING ISSUES ARISE:

- TAPE TRANSPORT SPEED HAS TO BE INCREASED IN DIRECT PROPORTION TO DATA RATE
- ELECTRONICS UNIT (EU) OF TAPE RECORDER SHOULD HAVE FAST RESPONSE TO HANDLE INCREASED DATA RATE

### R&D NEEDED

DESIGN AND DEVELOPMENT OF PRECISION SERVO CONTROLLED TRACKERS

TRANSPORT UNIT (TU) DESIGN IMPROVEMENT TO ACCOMODATE INCREASED SPEED

HIGH SPEED EU MUST BE DESIGNED AND DEVELOPED

VII-2-111



STANFORD  
TELECOMMUNICATIONS INC.

TECHNOLOGY ISSUES AND R&D NEEDED

(CONTINUED)

COMPONENT

ON-BOARD  
TAPE RECORDER

TECHNOLOGY ISSUES

- INCREASE IN SPEED IS ACCOMPANIED BY INCREASE IN
  - CHANNEL RELATED ELECTRONICS
  - POWER CONSUMPTION
  - COST
  - COMPLEXITY (LOSS OF RELIABILITY)
  
- EXTREMELY HIGH SPEED (~ 1 Gbps) TAPE RECORDERS REQUIRE A COMBINATION OF ROTARY HEADS AND MULTITRACK RECORDING WITH ASSOCIATED LIFE EXPECTANCY PROBLEMS

R&D NEEDED

DESIGN AND DEVELOPMENT OF EU USING LOW POWER CONSUMPTION, MINIATURIZED & HIGHLY RELIABLE COMPONENTS

DEVELOPMENT OF NON-CONTACT HEAD/TAPE INTERFACE TO ELIMINATE WEAR RELATED PROBLEMS

PRECEDING PAGE BLANK NOT REPRODUCED

VII-2-113



STANFORD  
TELECOMMUNICATIONS INC.

## ON-BOARD TAPE RECORDER UNIQUE R&D NEEDED

Comparing the R&D efforts needed to resolve each identified technology issue with undergoing design improvements and developments, the On-Board Tape Recorder unique R&D needed is identified. It has been assumed that the primary goal of these R&D efforts will be to achieve units with 300 Mbps record/reproduce rates, with a future goal of these activities being to achieve 1 Gbps rates.



ON-BOARD TAPE RECORDER UNIQUE R&D NEEDED

- DESIGN AND DEVELOPMENT OF PRECISION SERVO CONTROLLED TRACKERS TO ALLOW THE USE OF NARROW TAPE TRACKS
- DEVELOP TAPE TRANSPORT UNIT WHICH CAN OPERATE AT SPEEDS HIGH ENOUGH TO HANDLE  $\approx 0.3$  GBPS RECORD/REPRODUCE RATES (WITH FUTURE POTENTIAL TO 1 GBPS)
- DESIGN AND DEVELOPMENT OF ELECTRONICS UNIT WITH FOLLOWING CAPABILITIES
  - $\approx 0.3$  GBPS RECORD/REPRODUCE RATES (WITH FUTURE POTENTIAL TO 1 GBPS)
  - MINIATURIZED DESIGN
  - LOW POWER CONSUMPTION
  - HIGH RELIABILITY
- DEVELOPMENT OF NON-CONTACT HEAD-TAPE INTERFACE FOR HIGH SPEED APPLICATIONS

VII-2-115



STANFORD  
TELECOMMUNICATIONS INC.

CONCLUSIONS

It is concluded that with adequate levels of unique R&D activities, the listed storage, speed and weight/power capabilities can be achieved by 1990.

## CONCLUSIONS

WITH ADEQUATE R&D THE FOLLOWING CAN BE ACHIEVED BY 1990

- EXTREMELY HIGH STORAGE ( $> 10^{12}$  BITS)
- EXTREMELY HIGH RECORDING SPEED ( $\approx 1$  GBS)
- EXTREMELY HIGH REPRODUCE RATES ( $\approx 1$  GBS)
- ELECTRONICS UNIT CAN BE MINIATURIZED WITH  
> 2:1 REDUCTION IN WEIGHT AND POWER.

VII-2-117



STANFORD  
TELECOMMUNICATIONS INC.

2.1.1.4

T D A S   U S E R   S / C   A T T I T U D E   C O N T R O L  
S Y S T E M   T E C H N O L O G Y

PRECEDING PAGE BLANK NOT FILMED

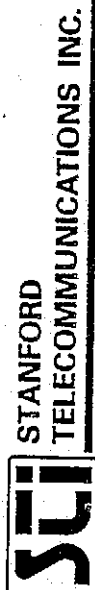

TDAS USER S/C ATTITUDE CONTROL SYSTEM TECHNOLOGY

The elements addressed in this section of the report are indicated.

## TDAS USER S/C ATTITUDE CONTROL SYSTEM TECHNOLOGY

- USER S/C ATTITUDE CONTROL SYSTEM (ACS) TASKS
- TYPICAL ATTITUDE CONTROL SYSTEM MANEUVERS
- TYPICAL PERFORMANCE REQMTS OF THE ACS OF A TDAS USER S/C
- FUNCTIONAL BLOCK DIAGRAM OF USER S/C ACS
- KEY COMPONENTS OF USER S/C ACS
- CHARACTERISTICS OF REPRESENTATIVE HARDWARE COMPONENTS
- TECHNOLOGY ISSUES AND R&D NEEDS
- TDAS USER S/C UNIQUE ACS R&D
- EXPECTED PERFORMANCE CAPABILITIES OF ACS OF 1990'S
- CONCLUSIONS

VII-2-121



STANFORD  
TELECOMMUNICATIONS INC.

## USER S/C ATTITUDE CONTROL SYSTEM TASKS

The user S/C Attitude Control System is required to perform a number of tasks as indicated. These are intended to determine and control the orientation and stabilization of the user S/C. These functions are to be provided during various operational modes which are listed on the chart.

## USER S/C ATTITUDE CONTROL SYSTEM TASKS

- TO PROVIDE:
  - ATTITUDE DETERMINATION
  - ORIENTATION (IN GEOCENTRIC OR INERTIAL REFERENCE SYSTEM)
  - STABILIZATION OF THE S/C
  
- DURING FOLLOWING OPERATIONAL MODES:
  - ORBIT TRANSFER
  - ORBIT ADJUSTMENT
  - SLEWING
  - NORMAL OPERATIONS
  - MISSION UNIQUE OPERATIONS
  - CALIBRATION OF INERTIAL REFERENCE UNIT
  - INERTIAL HOLD
  - SAFE HOLD

VII-2-123



STANFORD  
TELECOMMUNICATIONS INC.



TYPICAL ATTITUDE CONTROL SYSTEM MANEUVERS

Typical maneuvers which a user S/C bias momentum attitude control System has to perform and the purpose of each is stated on this chart.

## TYPICAL ATTITUDE CONTROL SYSTEM MANEUVERS

<u>MANEUVER</u>	<u>PURPOSE</u>
● POST SEPARATION	● GYROSCOPIC STABILITY AND SLOW BODY SCAN
● ATTITUDE REORIENTATION	● PREPARATION FOR ORBIT INJECTION
● SPIN UP	● SAME
● SPIN DOWN	● ADJUST S/C MOMENTUM FOR ON-ORBIT REQUIREMENTS
● ATTITUDE REORIENTATION	● ORIENT PITCH AXIS NORMAL TO ORBIT
● MOMENTUM BIAS ADJUSTMENT	● COMPENSATION OF SOLAR DISTURBANCE TORQUES
● CLOSE LOOP ROLL	● MAINTAIN ROLL/YAW ATTITUDE
● ORBIT ADJUSTMENT	● MAINTAIN ATTITUDE IN THE PRESENCE OF DISTURBANCES
● MOMENTUM ADJUSTMENT	● MAINTAIN BIAS MOMENTUM APPROXIMATELY CONSTANT

VII-2-125



STANFORD  
TELECOMMUNICATIONS INC.

TYPICAL PERFORMANCE REQUIREMENTS OF THE  
ATTITUDE CONTROL SYSTEM OF A TDAS USER S/C

The performance requirements of the attitude control system of a user S/C are dependent upon

- User S/C mission
- Operational and Communication interface requirements at the user S/C - TDAS S/C interface.

This necessitates that the performance requirements must be uniquely defined for each user S/C and mission. The listed requirements are representative of a fast maneuvering and tightly stabilized spacecraft and are not intended for any particular user S/C and/or mission.

TYPICAL PERFORMANCE REQUIREMENTS OF THE ATTITUDE  
CONTROL SYSTEM OF A TDAS USER S/C

● MANEUVERING CAPABILITY	MUST POSSESS ENTIRE CAPABILITIES AS DICTATED BY THE MISSION
● POINTING ACCURACY (RMS) (DEG)	$\pm 10^{-3} - 10^{-2}$
● POINTING STABILITY (DEG/SEC)	$\pm 10^{-7} - 10^{-6}$
● POINTING STABILITY ATTITUDE JITTER (DEG) (RELATIVE TO POINTING STABILITY AS BASE- LINE OVER $\leq 30$ MIN.)	$\pm 2 \times 10^{-4} - \pm 2 \times 10^{-3}$
● SLEW RATE (DEG/SEC)	0.2 - 2
● SLEW RATE STABILITY (30 DAYS)	0.005% - 0.01%
● WEIGHT	< 40 LBS
● POWER	< 15 W

VII-2-127



STANFORD  
TELECOMMUNICATIONS INC.

FUNCTIONAL BLOCK DIAGRAM OF USER S/C  
ATTITUDE CONTROL SYSTEM

The functional block diagram of a representative user S/C Attitude Control System (ACS) and its interfaces with key components of the user S/C are shown. The interface electronics is the interface between the attitude sensors, the Inertial Reference Unit (IRU) and the actuator electronics. The Remote Interface Unit (RIU) represents the interface between the On-Board Computer (OBC) and the ACS. The OBC generates actuator signals for the user S/C ACS using sensor data. The data from the OBC is transferred back and forth via a data bus through the RIU. The actuator signals from the OBC are submitted through the RIU to the wheel drive and propulsion electronics unit where necessary and required drive signals are generated for gimbal torquers, reaction wheels and/or thrusters.

FUNCTIONAL BLOCK DIAGRAM OF USER S/C  
ATTITUDE CONTROL SYSTEM

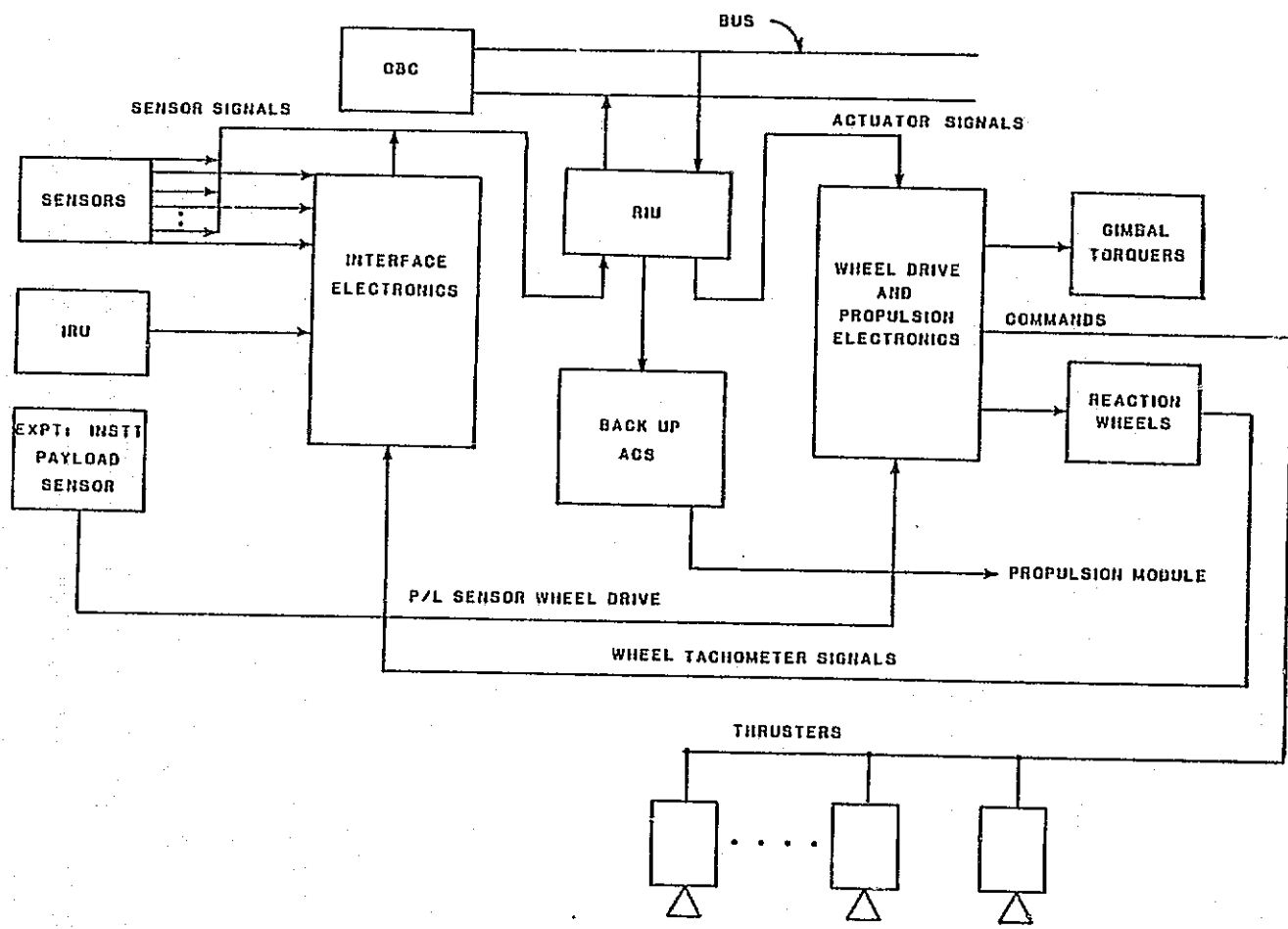

VII-2-129

ORIGINAL PAGE IS  
OF POOR QUALITY

FUNCTIONAL BLOCK DIAGRAM OF USER S/C  
ATTITUDE CONTROL SYSTEM (cont'd)

In addition to the usual ACS attitude Sensors, experiment-unique instrument payload Sensors may be used as dictated by the mission. The output of this Sensor is also fed to the wheel drive and propulsion electronics unit to null pointing errors.

Operational modes of the user S/C are controlled by the OBC. The OBC provides the flexibility of utilizing the ACS for various mission applications. The object of the "Back up" ACS is to provide a "Safe Hold" mode. In case of OBC failure, this controller will orient the S/C to a "Safe" mode of operation.

KEY COMPONENTS OF USER S/C ATTITUDE  
CONTROL SYSTEM

While the preceding chart depicted the functional block diagram of a representative user S/C Attitude Control System, the key components contained therein and the function of each is described in the three accompanying charts.

PRECEDING PAGE BLANK NOT FILMED



## KEY COMPONENTS OF USER S/C ATTITUDE CONTROL SYSTEM

### COMPONENT

### FUNCTION

- SENSORS
  - TO SENSE THE ATTITUDE OF USER S/C FOR SUBSEQUENT CONTROL OF ITS ATTITUDE. INITIAL ACQUISITION IS AIDED BY COARSE SUN SENSOR AND MAGNETOMETERS. SUBSEQUENTLY, PRINCIPAL ATTITUDE SENSOR IS INERTIAL REFERENCE UNIT (IRU) WHICH IS UPDATED BY STAR SENSOR AND FINE SUN SENSOR. A MISSION UNIQUE FINE ERROR SENSOR CAN BE USED IN MANY WAYS TO IMPROVE ATTITUDE CONTROL SYSTEM PERFORMANCE.
- IF ELECTRONICS
  - PROVIDES INTERFACE BETWEEN SENSORS AND:
    - REMOTE INTERFACE UNIT (RIU)
    - BACKUP ANALOG ATTITUDE CONTROL SYSTEM
- BACKUP ATTITUDE CONTROL SYSTEM
  - THIS UNIT, WHEN IMPLEMENTED, PROVIDES A BACKUP CAPABILITY IN CASE OF ON-BOARD COMPUTER FAILURE AND BRINGS USER S/C IN "SAFE" MODE OF OPERATION. BY COMMAND, THE "SAFE" MODE CAN BE TRANSFORMED INTO A MODE WHICH IS CAPABLE OF MEETING SHUTTLE CONTROL REQUIREMENTS.

VII-2-133



STANFORD  
TELECOMMUNICATIONS INC.

KEY COMPONENTS OF USER S/C ATTITUDE CONTROL SYSTEM (CONTINUED)

COMPONENT

FUNCTION

- REMOTE INTERFACE UNIT (RIU)

- TELEMETRY DATA IS ACQUIRED REMOTELY BY COMMUNICATION AND DATA HANDLING MODULE BY MEANS OF RIU. IT CAN ACCEPT ANALOG, SERIAL DIGITAL OR BI-LEVEL SIGNALS IN ADDITION TO CONDITIONING SIGNALS FROM PASSIVE TRANSDUCERS

- ON-BOARD COMPUTER (OBC)

- SUPPORT PROVIDED BY OBC TO ACS INCLUDES:
  - MODE CONTROL
  - SENSOR DATA PROCESSING
  - GENERATION OF REACTION CONTROL COMMANDS

OBC MAKES S/C HIGHLY VERSATILE SO THAT A SINGLE ACS DESIGN CONCEPT CAN BE ADAPTED TO A VARIETY OF MISSIONS WITH DIFFERENT POINTING, STABILIZATION AND SLEWING REQUIREMENTS.



STANFORD  
TELECOMMUNICATIONS INC.

KEY COMPONENTS OF USER S/C ATTITUDE CONTROL SYSTEM (CONTINUED)

<u>COMPONENT</u>	<u>FUNCTION</u>
● REACTION WHEEL	● TO ACHIEVE GYROSCOPIC STIFFNESS/STABILITY AND TO ENABLE MOMENTUM SINK FOR ATTITUDE CONTROL
● DRIVE ELECTRONICS	● TO GENERATE NECESSARY STIMULI FOR DRIVING WHEELS AND TORQUERS
● TORQUERS	● COMPENSATE SOLAR TORQUES, ETC.
● PROPULSION ELECTRONICS	● TO GENERATE NECESSARY SIGNALS FOR <ul style="list-style-type: none"><li>- ORBIT ADJUSTMENT</li><li>- ORBIT REORIENTATION</li><li>- SPIN AND MOMENTUM ADJUSTMENT</li></ul>
● NUTATION DAMPER	● TO ATTENUATE NUTATION
● GYROS	● TO SENSE ATTITUDE RATES AND INTEGRATED ATTITUDE RATES FOR CONTROLLING ATTITUDE



STANFORD  
TELECOMMUNICATIONS INC.

CHARACTERISTICS OF REPRESENTATIVE  
HARDWARE COMPONENTS

Representative hardware components of user S/C ACS and their characteristics are listed on the next five charts. The characteristics are representative of current State of the art capabilities.

## CHARACTERISTICS OF REPRESENTATIVE HARDWARE COMPONENTS

### TYPES AND KEY CHARACTERISTICS

#### SUN SENSOR

- PROVIDES ORIENTATION OF SUN VECTOR IN BODY COORDINATES
- FIELD OF VIEW (FOV) RANGES FROM SEVERAL SQUARE ARC-MINUTES TO  $\approx 128 \times 128$  DEG
- RESOLUTION RANGING FROM SEVERAL DEGREES TO LESS THAN 1-ARC-SEC

#### FINE SUN SENSOR

- PROVIDES ORIENTATION OF SUN VECTOR WITH HIGH ACCURACY
- FOV TYPICALLY RANGES FROM  $\pm 2$  DEG TO  $\pm 32$  DEG
- RESOLUTIONS LESS THAN  $1/8$  DEG-TO-0.1 ARC SEC CAN BE ACHIEVED

#### HORIZON SENSOR

- DESIGNED TO LOCATE THE EARTH'S HORIZON AND PROVIDE ORIENTATION OF S/C WITH RESPECT TO EARTH
- FOV IS TYPICALLY IN THE RANGE OF  $2 \times 2$  DEG

#### MAGNETOMETER

- THEY ARE VECTOR SENSORS (PROVIDE BOTH THE DIRECTION AND MAGNITUDE OF MAGNETIC FIELD)
- ACCURACY IS POOR; NOMINALLY  $\pm 10$  ARC MINUTES

#### STAR SENSOR

- MEASURE STAR COORDINATES IN S/C FRAME AND PROVIDE ATTITUDE INFORMATION WHEN THESE COORDINATES ARE COMPARED WITH KNOWN STAR DIRECTIONS OBTAINED FROM A STAR CATALOG
- HIGHLY ACCURATE  $\approx \pm 1$  ARC SEC
- FOV LIES IN THE RANGE  $1 \times 1$  DEG-TO- $10 \times 10$  DEG

VII-2-139



STANFORD  
TELECOMMUNICATIONS INC.

## CHARACTERISTICS OF REPRESENTATIVE HARDWARE COMPONENTS (CONTINUED)

### SUN-SENSORS

<u>FIELD OF VIEW (DEG)</u>	<u>ACCURACY (DEG)</u>	<u>WEIGHT (LB)</u>	<u>POWER (W)</u>
180 DEG FAN	0.5	1.3	0.3
6 DEG FAN	0.1	1.4	0.4
128 x 128	0.5	2.5	0.6
128 x 128	0.25	1.25	0.1
64 x 64	0.1	3.1	0.6
64 x 64	0.02	1.8	1.8
30 DEG CON	1	0.12	0 (1)
HEMISPHERIC	2	0.2	0 (1)

NOTE: (1) POWER IS ZERO BECAUSE SENSOR DOES NOT INCLUDE ELECTRONICS.



STANFORD  
TELECOMMUNICATIONS INC.

VII-2-141

PRECEDING PAGE BLANK NOT FILMED

CHARACTERISTICS OF REPRESENTATIVE HARDWARE COMPONENTS (CONTINUED)

HORIZON SENSORS

<u>FIELD OF VIEW (DEG)</u>	<u>RANGE (DEG)</u>	<u>WEIGHT (LB)</u>	<u>POWER (W)</u>
2 x 2	± 10	15	5.4
2 x 2	± 20	15	5.4
2 x 2	± 60	8	2.3

MAGNETIC INDUCTION MAGNETOMETER

<u>MAGNETIC FIELD RANGE (WEBER/M<sup>2</sup> X 10<sup>9</sup>)</u>	<u>NUMBER OF AXES</u>	<u>ACCURACY ARC-MIN</u>	<u>WEIGHT (LB) (SENSOR/ SENSOR ELECTRONICS)</u>	<u>POWER (W)</u>
± 32	3	± 15	.8/2	0.5
± 128	3	± 15	.8/2	0.5
± 200	3	± 15	.5/2	0.5
± 320	3	± 6	1/2	0.7
± 600	3	± 15	1/0.6	1.2
± 3200	3	± 6	1/2	0.7



STANFORD  
TELECOMMUNICATIONS INC.

## CHARACTERISTICS OF REPRESENTATIVE HARDWARE COMPONENTS (CONTINUED)

### STAR SENSORS

<u>DETECTOR USED</u>	<u>FIELD OF VIEW (DEG)</u>	<u>ACCURACY (ARC-SEC)</u>
PHOTO MULTIPLIER	0.03 CONE	$\pm 2$
PHOTO MULTIPLIER	8 x 8	$\pm 10$
PHOTO MULTIPLIER	10 x 10	$\pm 60$
PHOTO MULTIPLIER	1 x 1	$\pm 1.5$
PHOTO ELECTRON COUNTER	2 x 2	$\pm 1.5$

PRECEDING PAGE BLANK NOT FILMED

VII-2-145



STANFORD  
TELECOMMUNICATIONS INC.



CHARACTERISTICS OF REPRESENTATIVE HARDWARE COMPONENTS (CONTINUED)

RATE INTEGRATING GYRO

<u>INPUT ANGULAR SPEED RANGE</u> (DEG/SEC)	<u>RANDOM DRIFT</u> (DEG/HR)	<u>ANGULAR MOMENTUM</u> (GM CM <sup>2</sup> /SEC)	<u>WEIGHT</u> (LB)	<u>POWER</u> (W)
± 5.6	0.003	185,000	1.7	17
± 2.5	0.006	430,000	1.7	16

PRECEDING PAGE BLANK NOT FILMED

VII-2-147



STANFORD  
TELECOMMUNICATIONS INC.

## TECHNOLOGY ISSUES AND R&D NEEDED

Technology issues which resulted from the user S/C ACS technology assessment effort are listed in this chart along with R&D needed to resolve these issues. Identification of the technology issues and R&D needed is broken down on the basis of following components of the Attitude Control System:

- Sensors
- IF Electronics
- Drive and Propulsion Electronics Assembly
- Gyros
- On-Board Computer

The technology issues for the user S/C Attitude Control System are related to accuracy, perturbations and jitter of the S/C attitude and the ACS weight and power burden on the user S/C.

The attitude accuracy degrades due to Sensor errors because Sensor inaccuracies are directly reflected in attitude errors. Regarding the IF electronics assembly, its delay and amplitude versus frequency transmission characteristics are far from ideal. The actual transmission characteristics are non-uniform with respect to frequency. These non-uniformities distort the signal which in turn impairs the S/C attitude.

## TECHNOLOGY ISSUES AND R&D NEEDS

<u>COMPONENT</u>	<u>TECHNOLOGY ISSUES</u>	<u>R&amp;D NEEDED</u>
● SENSORS	● ATTITUDE ACCURACY DEGRADE DUE TO SENSOR ERRORS	● THE ACCURACY OF PRECISION SENSORS SHOULD BE ENHANCED BY AT LEAST AN ORDER OF MAGNITUDE
● IF ELECTRONICS	● THE AMPLITUDE AND DELAY VERSUS FREQUENCY NONUNIFORMITIES OF THE INTERFACE CAUSE THE SIGNAL IMPAIRMENTS TO PROPAGATE ALL THE WAY THROUGH TO ATTITUDE IMPAIRMENTS	● ATTITUDE IMPAIRMENTS MUST BE REDUCED TO MAINTAIN ATTITUDE ACCURACIES. IF ELECTRONICS SUBSYSTEM WITH NEARLY UNIFORM AMP. AND DELAY VS FREQ. CHARACTERISTICS MUST BE DEVELOPED.
● DRIVE AND PROPULSION ELECTRONICS ASSEMBLY	● HAVE HIGH WEIGHT/POWER BURDEN	● LOW CONSUMPTION, MMIC TECHNOLOGY BASED DRIVE/PROPULSION ELECTRONICS ASSEMBLIES MUST BE DEVELOPED
	● DRIVE/PROPULSION ELECTRONIC SIGNAL IMPAIRMENTS DEGRADE ATTITUDE CONTROL SYSTEM ACCURACY	
	● COMPONENT PARAMETER INSTABILITIES CAUSE ATTITUDE JITTER	● SYSTEMS RESEARCH STUDY MUST BE CONDUCTED TO IDENTIFY THE CAUSES OF SIGNAL IMPAIRMENTS, INSTABILITIES AND NOISE AND MOST PROMISING SOLUTION PRACTICALLY IMPLEMENTED AND ASSEMBLY PERFORMANCE DEMONSTRATED

VII-2-149



STANFORD  
TELECOMMUNICATIONS INC.

TECHNOLOGY ISSUES AND R&D NEEDED (CONTINUED)

The Drive and Propulsion Electronics Assembly (DPEA) also distorts the Signals which it handles, and these impairments degrade ACS accuracy. In addition, the instability (variations) of the parameter values of the components used to implement DPEA causes the transfer gain to vary which in turn causes the user S/C attitude to jitter. Concerning the impact of gyros on attitude accuracy, the contributing factors are gyro precision, gyro drift and bearing wear.

The DPEA is a major contributor to the ACS weight/power burdens; this is due mainly to the use of heavy and high power consuming electronic components in its implementation.

For each component and every technology issue associated with it, the R&D needed to resolve these issues is defined. The On-Board Computer plays a key part in the operation of most user S/C ACS, but this component is not addressed here because it is discussed as a separate Subsystem in this report.

## TECHNOLOGY ISSUES AND R&D NEEDS (CONTINUED)

<u>COMPONENT</u>	<u>TECHNOLOGY ISSUES</u>	<u>R&amp;D NEEDED</u>
● GYROS	● ATTITUDE ACCURACY DEGRADES DUE TO <ul style="list-style-type: none"><li>- INSUFFICIENT GYRO PRECISION</li><li>- GYRO DRIFT</li><li>- BEARING WEAR</li></ul>	● LOW DRIFT GYROS MUST BE DEVELOPED  ● OPTIMAL ESTIMATION SCHEMES USED FOR ATTITUDE ESTIMATION MUST INCLUDE PERFORMING GYRO DRIFT ESTIMATES.  KALMAN ESTIMATION SCHEMES WHICH ESTIMATE GYRO DRIFT AND MAKE USE OF THIS ESTIMATE TO ACHIEVE PRECISE ATTITUDES MUST BE STUDIED AND DEMONSTRATED BY SIMULATION  ● MECHANISM OF NONUNIFORM BEARING WEAR MUST BE BETTER UNDERSTOOD AND CORRECTED.
● ON-BOARD COMPUTER	● DISCUSSED SEPARATELY	● DISCUSSED SEPARATELY



STANFORD  
TELECOMMUNICATIONS INC.

TDAS USER S/C ATTITUDE CONTROL SYSTEM R&D

Comparing the R&D needed to resolve the ACS technology issues with on going development activities, the additional user S/C ACS unique R&D is identified.

TDAS USER S/C UNIQUE ATTITUDE CONTROL SYSTEM R&D

- CONDUCT R&D TO
  - ENHANCE PRECISION ATTITUDE SENSOR ACCURACY
  - IMPROVE TRANSMISSION CHARACTERISTICS OF INTERFACE ELECTRONICS ASSEMBLY
  - DESIGN AND DEVELOP MMIC TECHNOLOGY BASED DRIVE/PROPULSION AND INTERFACE ELECTRONICS ASSEMBLIES
  - ENHANCE GYRO PRECISION AND UNIFORMITY OF BEARING WEAR
  - STUDY KALMAN ESTIMATION SCHEMES TO SIMULTANEOUSLY ESTIMATE GYRO DRIFT AND ATTITUDE WITH POTENTIAL FOR INCREASED ATTITUDE CONTROL SYSTEM ACCURACY

VII-2-153



STANFORD  
TELECOMMUNICATIONS INC.

EXPECTED PERFORMANCE CAPABILITIES OF  
ATTITUDE CONTROL SYSTEMS BY 1990

Bases upon the assumption that user S/C ACS unique R&D is continued and maintained at an adequate level, the representative performance capability indicated can be expected to be achieved by 1990.



## EXPECTED PERFORMANCE CAPABILITIES OF ATTITUDE

### CONTROL SYSTEMS BY 1990

	ENTIRE MISSION DICTATED CAPABILITIES ACCOMMODATED
● MANEUVERING CAPABILITY	
● POINTING ACCURACY (RMS) (DEG)	$\pm 0.5 \times 10^{-3}$
● POINTING STABILITY (DEG/SEC)	$\pm 10^{-7}$
● POINTING STABILITY ATTITUDE JITTER (DEG) (RELATIVE TO POINTING STABILITY AS BASE- LINE OVER $\leq 30$ MIN)	$\pm 10^{-4}$
● SLEW RATE (DEG/SEC)	2
● SLEW RATE STABILITY (30 DAYS)	0.002%
● WEIGHT	< 35 LBS
● POWER	< 10 W

VII-2-155



STANFORD  
TELECOMMUNICATIONS INC.

CONCLUSIONS

Based upon the technology assessment effort performed, the listed conclusions are obtained.

## CONCLUSIONS

- WITH RECOMMENDED R&D ATTITUDE CONTROL SYSTEM ACCURACY REQUIREMENTS OF TDAS USER S/C CAN BE MET
- POINTING ACCURACY AND STABILITY OF ATTITUDE CONTROL SYSTEM DEPENDS UPON MISSION UNIQUE FACTORS
- AUGMENTING THE ATTITUDE CONTROL SYSTEM WITH EXPERIMENT UNIQUE PAYLOAD ATTITUDE SENSOR ENHANCES POINTING ACCURACY AND STABILITY
- ADDITION OF EXPERIMENT UNIQUE PAYLOAD ATTITUDE SENSORS WILL BE REQUIRED ESPECIALLY FOR MISSIONS WITH STRINGENT REQUIREMENTS

VII-2-157



STANFORD  
TELECOMMUNICATIONS INC.

2.1.5

ON - BOARD COMPUTERS TECHNOLOGY

PRECEDING PAGE BLANK NOT FILMED

STANFORD  
TELECOMMUNICATIONS INC.



ON-BOARD COMPUTERS TECHNOLOGY

The various elements of this section of the report are listed.

## ON-BOARD COMPUTERS TECHNOLOGY

- ON-BOARD COMPUTER (OBC) TASKS
- OBC AND S/C INTERFACES
- REQUIREMENTS OF TDAS USER S/C
- ON-BOARD COMPUTERS OF THE 1980's
- OBC TECHNOLOGY ISSUES AND R&D NEEDED
- ADDITIONAL USER S/C OBC UNIQUE R&D
- EXPECTED CHARACTERISTICS OF ON-BOARD COMPUTER OF THE 1990's
- CONCLUSIONS

VII-2-161



STANFORD  
TELECOMMUNICATIONS INC.

## ON-BOARD COMPUTER TASKS

On-Board Computer for user S/C are required to perform a number of tasks. These tasks are listed, and a brief description of each task is provided. With time, the spacecraft designers and configuration managers are increasingly relying on On-board Computers and associated data systems to make spacecraft more flexible in their operational capabilities and more autonomous.

## ON-BOARD COMPUTER TASKS

<u>TASK</u>	<u>BRIEF DESCRIPTION</u>
ATTITUDE DETERMINATION AND CONTROL:	THE ATTITUDE OF USER S/C IN SPACE MUST BE MAINTAINED. THIS IS PERFORMED BY ATTITUDE CONTROL SYSTEM (ACS) BY FIRST DETERMINING USER S/C ATTITUDE WITH ON-BOARD COMPUTER (OBC) USING ATTITUDE SENSOR DATA. USING APPROPRIATE ALGORITHMS OBC MAKES ATTITUDE DETERMINATION CALCULATIONS AND DETERMINES HOW THE S/C SHOULD BE ALIGNED AND ISSUES REQUISITE COMMANDS THAT ENABLE JETS, MAGNETIC THRUSTERS OR REACTION WHEELS TO BRING S/C TO DESIRED ATTITUDE.
COMMAND STORAGE:	STORES COMMANDS ALONG WITH THEIR EXECUTION TIMES FOR LATER EXECUTION (TIME TAGGED COMMANDS).
HOUSEKEEPING:	INVOLVES MONITORING AND CONTROLLING VARIOUS ELEMENTS WHICH DETERMINE THE HEALTH OF S/C.
EXECUTIVE:	A FUNCTION TO SEQUENCE ALL TASKS AND INPUT/OUTPUT OPERATIONS. A REAL-TIME, MULTITASKING, INTERRUPT DRIVEN EXECUTIVE IS USED FOR THE PURPOSE.

VII-2-163



STANFORD  
TELECOMMUNICATIONS INC.



ON-BOARD COMPUTER TASKS (CONTINUED)

On-Board computers for user S/C are required to perform a number of tasks. These tasks are listed, and a brief description of each task is provided. With time, the spacecraft designers and configuration managers are increasingly relying on On-Board Computers and associated data systems to make spacecraft more flexible in their operational capabilities and more autonomous.

## ON-BOARD COMPUTER TASKS (CONTINUED)

<u>TASK</u>	<u>BRIEF DESCRIPTION</u>
DATA FORMATTING:	CONTROLS THE SAMPLING AND FORMATTING OF THE ON-BOARD TELEMETRY POINTS
INSTRUMENT SEQUENCING AND CONTROL:	OBC ACCOMPLISHES THIS BY: <ul style="list-style-type: none"><li>● MONITORING ON-BOARD INSTRUMENTS</li><li>● CONTROLLING INSTRUMENTS DIRECTLY OR BY SUPPORTING THEIR MICROPROCESSORS</li><li>● DATA STORAGE MANAGEMENT</li><li>● RECORDING DATA WHEN TDAS SATELLITE IS NOT VISIBLE TO USER S/C</li><li>● DUMPING DATA WHEN TDAS SATELLITE IS VISIBLE TO USER S/C.</li><li>● USING NECESSARY TDAS SATELLITE AND USER S/C EPHEMERIS DATA OBC COMPUTES FROM POINTING ALGORITHM CORRECTIVE TORQUES TO BE IMPARTED TO USER S/C ANTENNA GIMBALS SO THAT IT REMAINS POINTED AT TDAS SATELLITE.</li></ul>
ANTENNA POINTING AND CONTROL	



STANFORD  
TELECOMMUNICATIONS INC.

## ON-BOARD COMPUTER AND S/C INTERFACES

The figure depicts the generic functional block diagram of a simplified communications and data handling (C&DH) system of a user S/C including the On-Board Computer (OBC) and key interfaces. In this configuration, the OBC resides in the C&DH module which contains telemetry transmitters and command receivers for S/C operation, tape recorder for temporary data storage, a S/C clock to provide basic timing reference signals for the S/C, Standard Telemetry and Command Components (STACC) and the multiplex data bus which links various components of the S/C via Remote Interface Units (RIUs). The STACC Central Unit is the main interface between the S/C data bus and the following elements:

- Telemetry Modulator
- Telemetry Transmitter
- Command Modulator
- Command Transmitter
- OBC.

The multiplex data bus has both supervisory and reply lines. Each S/C component is linked to the data bus via a Remote Interface Unit (RIU). The bus supervisory and reply lines are time division multiplexed. The former carry command messages and addresses for interrogated telemetry.

# ON-BOARD COMPUTER AND S/C INTERFACES

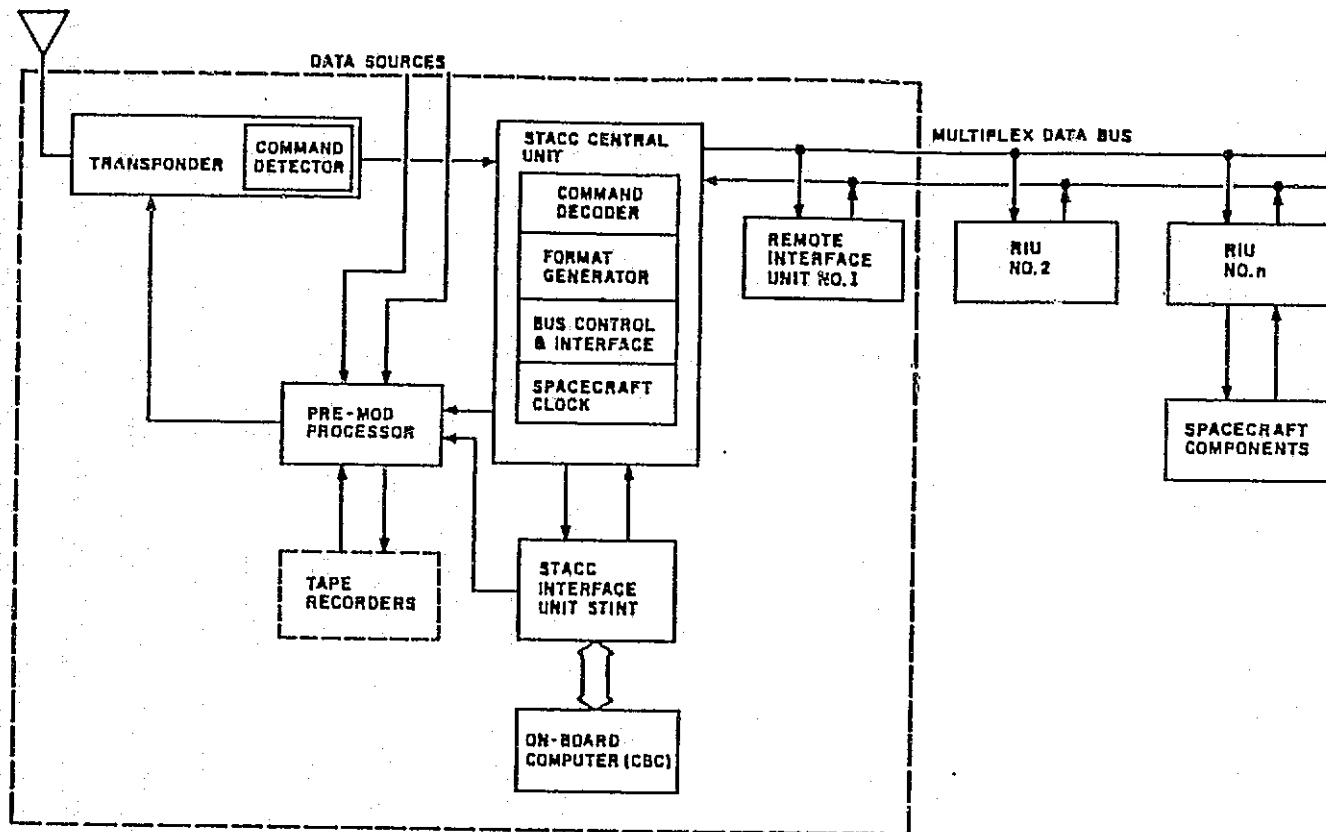

ORIGINAL PAGE IS  
OF POOR QUALITY

VII-2-167



STANFORD  
TELECOMMUNICATIONS INC.

REQUIREMENTS FOR TDAS USER S/C

The chart lists the OBC requirements of TDAS user S/C. Since each user S/C will have unique requirements, depending upon its mission and the various tasks assigned to the OBC, these requirements are meant to be representative and not for any specific user S/C.

## REQUIREMENTS FOR TDAS USER S/C

<u>PARAMETER</u>	<u>EXPECTED VALUE</u>
WORD LENGTH (BITS)	32
MAX MEMORY SIZE	90 K
AVERAGE INSTRUCTION SPEED ( $\mu$ SEC)	
- ADD	0.5
- MULTIPLY	5.0
NUMBER OF INSTRUCTIONS	$\approx$ 100
<u>FEATURES</u>	
DOUBLE PRECISION	YES
FLOATING POINT	YES
MICROPROGRAMMABLE	YES
OTHER	ERROR DETECTION ERROR CORRECTION MEMORY PROTECTION FAULT TOLERANT
<u>TECHNOLOGY</u>	
MEMORY TECHNOLOGY	CMOS, CMOS-VLSI
CPU TECHNOLOGY	SCHOTTKY TTL
<u>PHYSICAL CHARACTERISTICS</u>	
POWER (W)	< 40
WEIGHT (LB)	< 50



STANFORD  
TELECOMMUNICATIONS INC.

ON-BOARD COMPUTERS OF THE 1980'S

The table depicts a representative profile of the characteristics of the On-Board Computers of the 1980's. All of the key characteristics are addressed.

## ON-BOARD COMPUTERS OF THE 1980'S

DESIGNATION	NSSC-I	NSSC-II	ENHANCED NSSC-I	LITTON 4516 E	RAYTHEON	TELEDYNE MECA-43	CDC 469	APPLIED TECHNOLOGY ATAC-16 MS
<b>PARAMETERS</b>								
WORD LENGTH (BITS)	18	16/32	18	16/32	32	16	16/32	16/32
MAX MEMORY SIZE	64k	40k	96k	64k	96k	64k	16k	64k
AVERAGE INSTRUCTION SPEED (μSEC)								
- ADD	5	3.2	5	2.5	5.4	3	4	.53
- MULTIPLY	38	34.7	38	20.4	11	12.6	10.4	5.4
NUMBER OF INSTRUCTIONS	55	108	55	70	95-128	88	42	129
<b>FEATURES</b>								
DOUBLE PRECISION	NO	NO	NO	YES	YES	YES	YES	YES
FLOATING POINT	NO	YES	NO	YES	YES	YES	NO	YES
MICROPROGRAMMABLE	NO	NO	NO	YES	NO	YES	NO	YES
OTHER	MEMORY PROTECTION	FAULT TOL. MEMORY PROTECTION	MEMORY PROTECTION	ERROR DET. AND CORRECTION	MEMORY PROTECTION ERROR CORRECTION FAULT OVERRIDE	ERROR DET. AND CORRECTION MEMORY PROTECTION		

VII-2-171

ORIGINAL PAGE IS  
OF POOR QUALITY



**STANFORD  
TELECOMMUNICATIONS INC.**



ON-BOARD COMPUTERS OF THE 1980'S (CONTINUED)

The table depicts a representative profile of the characteristics of the On-Board Computers of the 1980's. All of the key characteristics are addressed.

ON-BOARD COMPUTERS OF THE 1980'S (CONTINUED)

DESIGNATION	NSSC-I	NSSC-II	ENHANCED NSSC-I	LITTON 4516 E	RAYTHEON	TELEDYNE MECA-43	CDC 469	APPLIED TECHNOLOGY ATAC-16 MS
<u>TECHNOLOGY</u>								
MEMORY TECHNOLOGY	CORE	N MOS	CORE	SEMICONDUCTOR	CMOS-LSI	CMOS CORE OR BIPOLAR	PLATED- WIRE	CMOS
CPU TECHNOLOGY	TTL-LSI	TTL	TTL-LSI	SCHOTTKY BIPOLAR TTL	CMOS-LSI	SCHOTTKY	PMOS	SCHOTTKY TTL
<u>PHYSICAL CHARACTERISTICS</u>								
POWER (W)	31	240	36	75	35	65	20	34
WEIGHT (LB)	17.4	29	-	12.5	50	35	10	18
SPACE QUALIFIED	YES	NO	NO	YES	NO	NO	YES	YES

ORIGINAL PAGE IS  
OF POOR QUALITY



STANFORD  
TELECOMMUNICATIONS INC.

ON-BOARD COMPUTER TECHNOLOGY ISSUES AND R&D NEEDED

The chart presents technology issues and associated R&D efforts needed to resolve these issues as they pertain to the OBC that may be required for user S/C in the TDAS era. The issues are based on the assumption that, with time, OBCs will be required to perform an increasing number of tasks with increased precision and reliability.

## ON-BOARD COMPUTER TECHNOLOGY ISSUES AND R&D NEEDED

<u>COMPONENT</u>	<u>TECHNOLOGY ISSUE</u>	<u>R&amp;D NEEDED</u>
ON-BOARD COMPUTER	<ul style="list-style-type: none"><li>● COMPLEX MATHEMATICAL COMPUTATIONS REQUIRE FLOATING POINT CAPABILITY IN OBC</li><li>● PROGRAMMING EFFICIENCY DEPENDS UPON PROGRAMMING LANGUAGE USED. FOR PERFORMING COMPLEX COMPUTATIONS, THE USE OF HIGHER ORDER LANGUAGES IS MORE APPEALING THAN ASSEMBLY LANGUAGE. BUT HIGHER ORDER LANGUAGES MAKE TESTING AND MAINTENANCE MORE DIFFICULT</li><li>● THE SOFTWARE OF ON-BOARD COMPUTERS IS TESTED BY SIMULATING A LARGE COMPUTER ON GROUND. OFTEN OBC CRASHES BECAUSE OF AN OBSCURE SET OF CONDITIONS NOT THOUGHT OF DURING SIMULATION.</li></ul>	<ul style="list-style-type: none"><li>● MOST DESIRABLE FLOATING POINT CAPABILITY IS 24-BIT MANTISSA AND 8-BIT EXPONENT WHICH REQUIRES A 32-BIT WORD SIZE. INVESTIGATE CANDIDATE TECHNIQUES TO IMPLEMENT THIS CAPABILITY AND MAKE A COMPARATIVE EVALUATION TO IDENTIFY OPTIMUM APPROACH.</li><li>● RESEARCH TO IDENTIFY LANGUAGE WHICH IS<ul style="list-style-type: none"><li>- EASIER TO DEBUG</li><li>- EASIER TO CHANGE</li><li>- COST EFFECTIVE</li></ul></li><li>● MEANS FOR DEBUGGING AND PATCHING THE SOFTWARE IN A COMPUTER WHICH IS IN ORBIT ARE HIGHLY DESIRABLE.</li></ul>

VII-2-175



STANFORD  
TELECOMMUNICATIONS INC.

ON-BOARD COMPUTER TECHNOLOGY ISSUES AND R&D NEEDED (CONTINUED)

The chart presents technology issues and associated R&D efforts needed to resolve these issues as they pertain to the OBC that may be required for user S/C in the TDAS era. The issues are based on the assumption that, with time, OBCs will be required to perform an increasing number of tasks with increased precision and reliability.

ON-BOARD COMPUTER TECHNOLOGY ISSUES AND R&D NEEDED (CONTINUED)

COMPONENT

TECHNOLOGY ISSUE

R&D NEEDED

- SINCE HARDWARE REPAIRS TO OBC CAN NOT BE MADE WHILE USER S/C IS IN ORBIT, RELIABILITY AND SPACE QUALIFICATION ARE CRITICAL ISSUES
- THE RELIABILITY OF SENSITIVE COMPONENTS MUST BE ENHANCED. IN ADDITION, MORE STRICT RELIABILITY DEMONSTRATION STANDARDS MUST BE PLACED ON
  - COMPONENTS
  - ASSEMBLIES
  - MODULES
- IT IS NECESSARY TO HAVE A 32-BIT PROCESSOR TO ENABLE MAKING COMPLEX MATHEMATICAL MANIPULATIONS
- A 32-BIT PROCESSOR SHOULD BE DESIGNED, DEVELOPED AND DEMONSTRATED FOR SPACE USE

VII-2-177



STANFORD  
TELECOMMUNICATIONS INC.

ADDITIONAL USER S/C ON-BOARD COMPUTER UNIQUE R&D

Comparing the R&D efforts needed to resolve each identified technology issue with the improvements to designs and developments that are underway, the user S/C OBC unique R&D needs are enumerated.

ADDITIONAL USER S/C ON-BOARD COMPUTER UNIQUE R&D

● CONDUCT R&D NECESSARY TO:

- DEVELOP 32-BIT FLOATING POINT PROCESSOR
- DEVELOP HIGHER ORDER PROGRAMMING LANGUAGE WHICH IS EASILY DEBUGGED DOWN TO BEING ERRORLESS
- GENERATE IN ORBIT PATCH TECHNIQUE TO REMOVE RESIDUAL DEBUGGING ERRORS
- ENHANCE RELIABILITY TO GREATER THAN FIVE YEAR LIFE
- MAKE UNIT IMMUNE TO RADIATION INDUCED ERRORS.

VII-2-179



STANFORD  
TELECOMMUNICATIONS INC.



EXPECTED CHARACTERISTICS OF ON-BOARD COMPUTERS BY 1990

Based upon the current OBC capabilities, R&D efforts going on in the NASA and industrial sectors and the use of engineering judgement, it is expected that the OBC characteristics listed on the chart can be achieved by 1990.

## EXPECTED CHARACTERISTICS OF ON-BOARD COMPUTERS BY 1990

<u>PARAMETER</u>	<u>EXPECTED VALUE</u>
WORK LENGTH (BITS)	32
MAX MEMORY SIZE	> 128 K
AVERAGE INSTRUCTION SPEED ( $\mu$ SEC)	
- ADD	0.25
- MULTIPLY	2.5
NUMBER OF INSTRUCTIONS	> 150
<u>FEATURES</u>	
DOUBLE PRECISION	YES
FLOATING POINT	YES
MICROPROGRAMMERS	YES
OTHER	ERROR DETECTION ERROR CORRECTION MEMORY PROTECTION FAULT TOLERANT
<u>TECHNOLOGY</u>	
MEMORY TECHNOLOGY	CMOS, CMOS-VLSI
CPU TECHNOLOGY	SCHOTTKY TTL
<u>PHYSICAL CHARACTERISTICS</u>	
POWER (W)	< 20
WEIGHT (LB)	< 25



STANFORD  
TELECOMMUNICATIONS INC.

CONCLUSIONS

The conclusions that are arrived at as a result of this technology assessment are listed.

## CONCLUSIONS

- TDAS USER S/C REQUIREMENTS ARE MORE DEMANDING (COMPARED TO, FOR EXAMPLE, A TDRSS USER) DUE TO:
  - WITH TIME, INCREASING NUMBER OF ROLES ARE BEING DELEGATED TO OBC
  - STRINGENT POINTING ACCURACIES OF 60 GHZ USER S/C ANTENNA POINTING AND CONTROL SYSTEM WILL REPRESENT ADDITIONAL BURDEN ON OBC
- AN ARRAY OF COMPUTERS ARE IN DEVELOPMENT STAGES
- WITH ADDITIONAL R&D SELECTED CANDIDATES OUT OF THEM CAN BE DEVELOPED TO MEET TDAS USER S/C REQUIREMENTS
- IF R&D IS CONTINUED, A TDAS USER S/C OBC WITH ENHANCED CAPABILITIES CAN BE DEVELOPED BY 1990.

VII-2-183



STANFORD  
TELECOMMUNICATIONS INC.

2.2

T D A S SPACECRAFT TECHNOLOGY ASSESSMENT

PRECEDING PAGE BLANK NOT FILMED

 STANFORD  
TELECOMMUNICATIONS INC.

2.2.1

SMA SUBSYSTEM TECHNOLOGY

The elements addressed in this section of the report are indicated.

SMA SUBSYSTEM TECHNOLOGY

- SMA S/S REQUIREMENTS FOR TDAS
- FUNCTIONAL BLOCK DIAGRAM
- SUMMARY/CONCLUSIONS
- DESIGN ALTERNATIVES AND TECHNOLOGY OF KEY COMPONENTS
  - PHASED ARRAY
  - BEAM FORMING
  - PHASED ARRAY ELEMENT
    - CRITICAL TECHNOLOGY ISSUES
    - R&D NEEDED
- ADDITIONAL SMA UNIQUE R&D NEEDED

VII-2-187



STANFORD  
TELECOMMUNICATIONS INC.

## SMA SUBSYSTEM REQUIREMENTS FOR TDAS

The TDAS imposed requirements on the S-Band Multiple Access (SMA) Subsystem are listed. These requirements are driven by the need to enhance SMA capabilities, specifically the following:

- Increasing the number of forward channels to two (2).
- Gain Enhancement
- On-Board Beam Forming.



SMA SUBSYSTEM REQUIREMENTS FOR TDAS

- CHANNELS:
  - FORWARD - 2 (EACH TIME SHARED)
  - RETURN - 1
- FOV: 26° CONICAL
- TRAFFIC CAPABILITY: 10 USER S/C SERVED SIMULTANEOUSLY
- PERFORMANCE ENHANCEMENT:
  - 3 - DB INCREASED GAIN
  - REDUCED BEAM FORMING LOSSES
  - ENHANCED PHASED ARRAY ELEMENT GAIN

VII-2-189



STANFORD  
TELECOMMUNICATIONS INC.

## FUNCTIONAL BLOCK DIAGRAM OF SMA MODULE

The associated chart depicts the functional block diagram of the SMA module and its various subsystems, namely:

- Frequency Division Multiplexer
- Switch
- Frequency Converter
- Return Beam Forming Network, BFN (RETURN)
- Front End Assembly
- Forward Beam Forming Network, BRN (FORWARD).

In addition, the return channel from TDAS to the ground and the forward channel from the ground to TDAS are shown on a functional basis for completeness although these are not part of the SMA module.

The return channel transmits (to ground locations) data gathered from various users of the SMA subsystem via the Switch and Multiple Beam Antenna (MBA). The Signals are routed through the Switch to the desired feed of the MBA Subsystem. The Signals impinging upon various elements of SMA phased array from various user S/C are received by the front end assembly consisting of filters and preamplifiers. The array elements employed for both forward and return link transmission are diplexed while those used only for return link communication do not contain any diplexers.

# FUNCTIONAL BLOCK DIAGRAM OF SMA MODULE

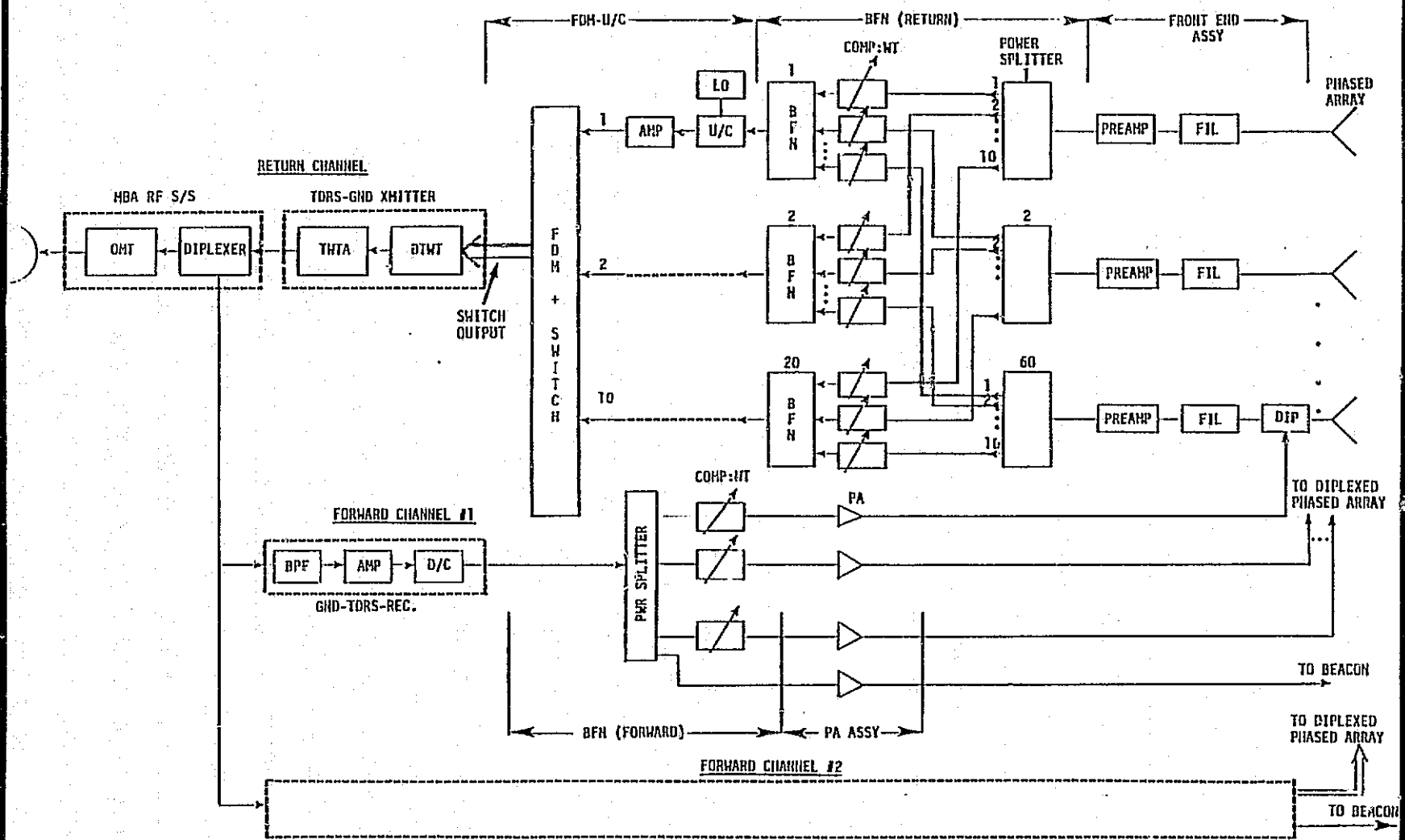

ORIGINAL PAGE IS  
OF POOR QUALITY

VII-2-191

## FUNCTIONAL BLOCK DIAGRAM OF SMA MODULE (CONTINUED)

The purpose of the BRN (RETURN) that follows is to form the beam associated with each user S/C using the multiple access service. The beam forming process involves power splitting, weighting and combining functions. In the return link transmission, the signal received by each phased array element is power split into as many components as needed to match the maximum number of user S/C that can use the multiple access service on a simultaneous basis. The number of power splitters is equal to the number of phased array elements. The 'k'th output of each power splitter, when processed in the BFN (RETURN) processor, provides the "formed beam" for the 'k'th user S/C. The signal derived from this formed beam is passed on to the frequency converter, FDM and switch for downlink transmission to the appropriate ground terminal. The SMA module performs the BFN function on board the TDAS Satellite.

Two identical forward link channels are provided, with each using twelve (12) diplexed phased array elements. The TDAS Satellite ground receiver accepts the signals from the ground for forward transmission to user spacecraft. For forward transmissions, the antenna beam for each individual user S/C is formed by a beam forming network (BFN (FORWARD)). With the power assembly providing the RF power, the forward channel transmits the signals to their respective user S/C.

## DESIGN ALTERNATIVES FOR SMA PHASED ARRAY

The existing multiple access subsystem on the TDRS Spacecraft has a thirty (30) element phased array antenna, and beam forming processing is done on the ground. In the enhanced TDAS spacecraft the beam forming function will be carried out on board the S/C. In addition, the multiple access system will be enhanced by increasing the number of elements in the phased array as well as improving the gain of each element. An assessment of the technology for achieving these improvements was made. Based upon this assessment, the chart lists key element of the design alternatives for the SMA phased array. From the presented design alternatives, it can be judged that sixty (60) element phased array designs using helix elements with improved gain characteristics can provide at least a 3 dB enhancement in the phased array antenna gain.

PRECEDING PAGE BLANK NOT FILMED

## DESIGN ALTERNATIVES FOR SMA PHASED ARRAY

TYPE OF ELEMENT	NO. OF ELEMENTS	ELEMENT FOV deg	PRESENT GAIN dB	THEORETICAL LIMIT GAIN	IMPROVED HELIX GAIN dB	PHASED ARRAY ANTENNA GAIN dB (IMP. HELIX)	COMPLEXITY-WEIGHT
HELIX	30	27	16	17.5	17	31.77	LOW
HELIX	40	27	16	17.5	17	33.02	LOW
HELIX	60	27	16	17.5	17	34.77	MED.

VII-2-195



STANFORD  
TELECOMMUNICATIONS INC.

PHASED ARRAY ANTENNA WITH 60 ELEMENTS

The figure shows the placement pattern for the Sixty (60) elements of the phased array. The dimension of the phased array is nominally ninety (90) inches in diameter, which will allow interelement spacing to be optimized to provide the required gain and field-of-view.

PHASED ARRAY ANTENNA WITH 60 ELEMENTS

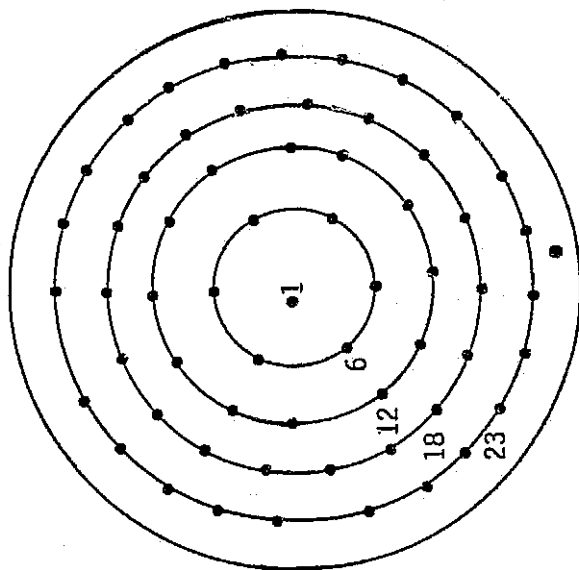

STANFORD  
TELECOMMUNICATIONS INC.





## ON-BOARD BEAM FORMING ALTERNATIVE

In the TDRS Multiple Access Subsystem, beam forming processing is done on the ground. Besides requiring approximately 200 MHz of bandwidth from the TDRS to the ground, this also causes beam forming losses. To minimize these losses, frequent calibration of the channel handling multiple access signals is required. These issues and the rapid rate at which technological advances are being made in the area of electronic components, processors, and size/volume/power shrinkage of electronics equipment motivates locating the beam forming subsystem on-board the TDAS. The chart lists various advantages for this approach. The only disadvantage is the increase in the weight/power burden on the TDAS.

ON-BOARD BEAM FORMING ALTERNATIVE

- BEAM FORMING LOSSES REDUCE
- SMA GAIN ENHANCES
- RETURN CHANNEL TRANSFER CHARACTERISTICS NOT SO CRITICAL
- LESS FREQUENT OR NO RETURN CHANNEL CALIBRATION NEEDED
- DOWNLINK BANDWIDTH REQMTS. REDUCE
- WEIGHT/POWER BURDEN ON TDAS INCREASES

VII-2-199



STANFORD  
TELECOMMUNICATIONS INC.

FUNCTIONAL BLOCK DIAGRAM  
(EXISTING TDRS SMA RETURN CHANNEL)

The chart depicts the functional block diagram of the existing TDRS SMA return channel with the objective of:

- Showing its various elements
- Depicting in detail the functions carried out in the return processor to achieve efficient beam forming.

Between A and B the return processor is located. Its ultimate objective is to make sure that a constant amplitude signal is fed to components located downstream from B which are the K-band upconverter, TWTA, diplexer and the Space-to-ground (SGL) link antenna. This ensures no amplitude fluctuations are imparted and therefore no AM/PM conversion takes place within the TWTA which might degrade the beam forming efficiency on the ground. For the same reason, the return processor provides automatic amplitude leveling, limiting and gain control on ground commands.

# FUNCTIONAL BLOCK DIAGRAM (EXISTING TDRS SMA RETURN CHANNEL)

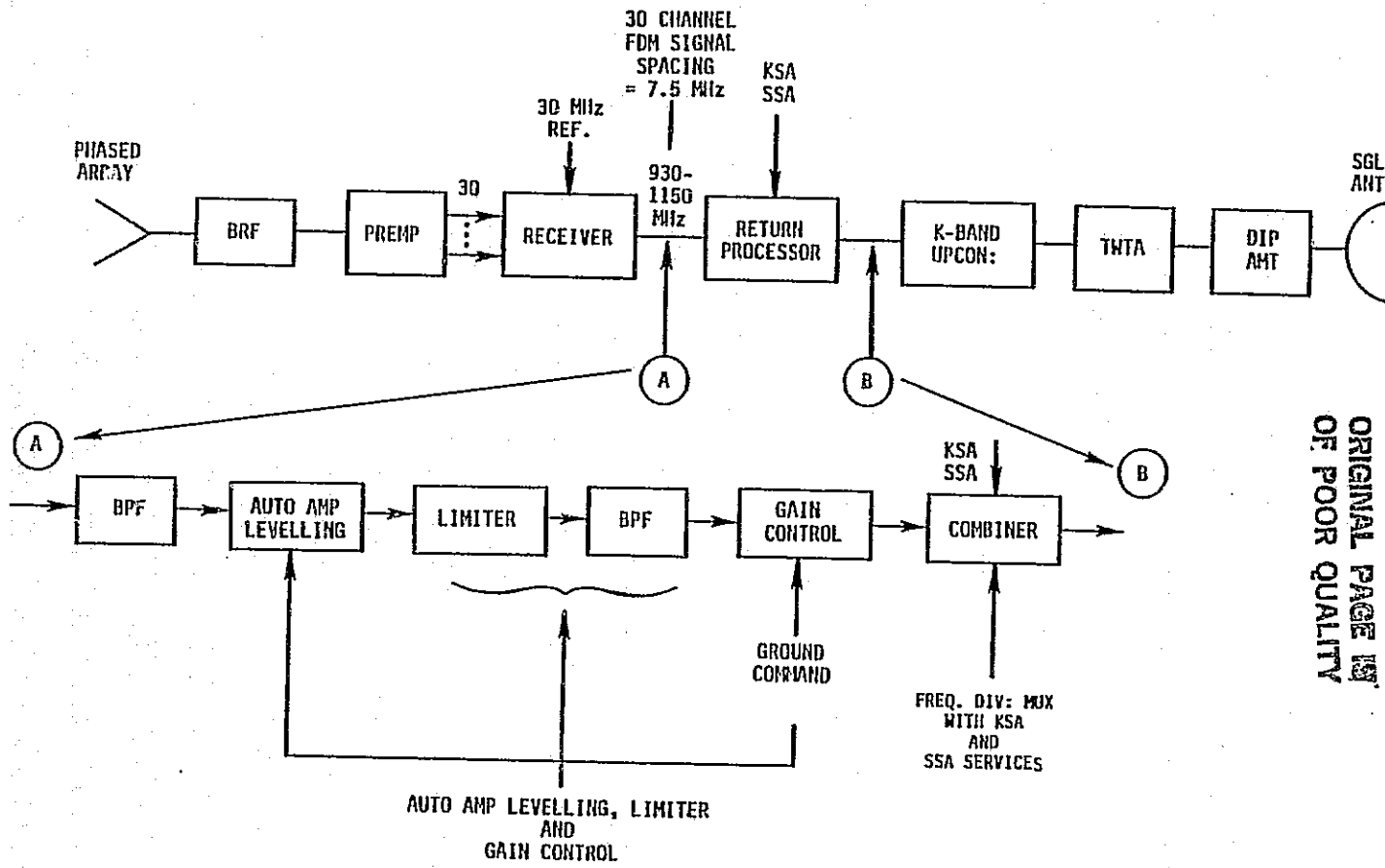

ORIGINAL PAGE IS  
OF POOR QUALITY

VII-2-201



**STANFORD  
TELECOMMUNICATIONS INC.**

## CHARACTERISTICS OF EXISTING TDRS SMA RETURN CHANNEL

The characteristics of the existing SMA return channel are expressed in the chart. The importance of these characteristics lies in their keeping the beam forming losses to a minimum. Because these losses degrade the antenna gain, they must be adequately addressed and controlled by an appropriate configuration and design for the SMA channel. The steps taken to ensure this in the existing TDRS SMA return channel are stated.

CHARACTERISTICS OF EXISTING TDRS SMA RETURN CHANNEL

- SIGNAL TRANSFER CHARACTERISTICS ARE CRITICAL TO BEAM FORMING WITH REASONABLE BEAM FORMING LOSSES.
- TO ENSURE REASONABLE BEAM FORMING LOSSES:
  - AUTOMATIC AMPLITUDE LEVELLING
  - SIGNAL LIMITING
  - GAIN CONTROL

ARE PROVIDED BY THE RETURN PROCESSOR TO ENSURE RETURN CHANNEL TWTA TO OPERATE IN

- PREASSIGNED BACK-OFF MODE
- MAINTAIN RELATIVE LEVELS OF VARIOUS SIGNALS AT CORRECT VALUES.
- MA ARRAY ELEMENT SIGNALS ARE RADIATED TO GROUND WITHOUT APPRECIABLY DISTORTING SIGNAL AMPLITUDE AND PHASE CHARACTERISTICS
- RETURN CHANNEL IS PERIODICALLY CALIBRATED.

VII-2-203



STANFORD  
TELECOMMUNICATIONS INC.

### APPLICABLE CAUSES OF BEAM FORMING LOSS

The beam forming losses are due to gain and phase impairment caused by various components of the Multiple Access (MA) return channel, starting from signal reception by MA antenna up to the point where beam forming is done. The chart tabulates the impairments due to various components in the existing MA channel. The components which contribute to associated beam forming impairments when beam forming is done on the ground are identified. Also identified are the contributing components if alternately the beam forming were done on board the S/C. The number of contributing components when beam forming is done on board are fewer; thus, reduced beam forming losses are suffered. The expected reduction in beam forming losses when beams are formed on board is  $\approx 1$  dB. Therefore, this is an attractive approach.

APPLICABLE CAUSES OF BEAM FORMING LOSS

APPLICABLE BEAM FORMING IMPAIRMENT	COMPONENT	GAIN IMPAIRMENT (DB)			PHASE IMPAIRMENT	
		LINEAR PK PK	PAR PK	RIPPLE PK-PK	TOTAL PHASE NONLINEARITY (DEG)	DIFFERENTIAL PHASE STABILITY (DEG)
<div style="display: flex; justify-content: space-between; align-items: center;"> <div style="text-align: center;">             ON GROUND BEAM FORMING              ↑              ↓           </div> <div style="text-align: center;">             ON BOARD BEAM FORMING              ↓              ↑           </div> </div>	MA ANTENNA					+ 5
	CABLE (ANT-DIP)					+ 1
	(MA DIPLEXER (OR BRF)			0.2	+ 0.5	+ 4
	CABLE (DIP-PREAMP)					+ 0.5
	PREAMP			0.2	+ 2.0	+ 6
	CABLE (PREAMP-REC)					+ 3.6
	RECEIVER		1.5	0.7	+ 0.5	+ 0.0
	RETURN PROCESSOR			0.2	+ 0.3	+ 5
	AUTO: AMP LEVEL/ LIMITER/GAIN CONTROL				+ 0.5	
	UPCONVERTER		0.1	0.2	+ 1.6	+ 4
	TWTA	0.1		0.2	+ 0.8	+ 3
	DIPLEXER (SGL)					+ 2
	MISMATCH					
FILTER (SGL)				+ 1.1		

REDUCTION IN BEAM FORMING LOSS = 1 DB

VII-2-205



**STANFORD  
TELECOMMUNICATIONS INC.**



## SMA ELEMENT PARAMETERS AND GAIN CAPABILITY

The chart identifies the possibility of improving the gain of the phased array antenna element by comparing the actual gain with what is theoretically possible (gotten by computations using the parameters of the existing element on the TDRS). The actual gain is 16 dB, while the theoretically possible value is 17.5 dB. Allowing 0.5 dB for losses, this leaves room for a 1 dB improvement in element gain.

SMA ELEMENT PARAMETERS AND GAIN CAPABILITY

PARAMETERS OF EXISTING ELEMENT

WAVELENGTH = 0.131 m  
HELIX DIA = 0.04 m  
SPACING BETWEEN  
HELIX TURNS = 0.027 m  
NUMBER OF TURNS = 19

POSSIBLE GAIN

$$G_{\text{POSSIBLE}} = 17.5 \text{ dB}$$

ACTUAL GAIN

$$G_{\text{ACTUAL}} = 16 \text{ dB}$$

THERE IS ROOM FOR = 1 DB IMPROVEMENT IN ELEMENT GAIN



STANFORD  
TELECOMMUNICATIONS INC.

SUMMARY/CONCLUSIONS

The summary/conclusions resulting from the technology assessment for the SMA module to enhance its capabilities are stated.

SUMMARY/CONCLUSIONS

- IT IS POSSIBLE TO GET 3-5 DB IMPROVED SMA BY
  - USING 60 ELEMENTS
  - ENHANCING ELEMENT GAIN
  - ON BOARD BEAM FORMING
- WITH ON BOARD BEAM FORMING LITTLE OR NO CHANNEL CALIBRATION WILL BE REQUIRED
- RETURN CHANNEL CHARACTERISTICS NOT CRITICAL FOR EFFICIENT BEAM FORMING
- TDAS-TO-GROUND BANDWIDTH IS CONSERVED

C-3

VII-2-209



STANFORD  
TELECOMMUNICATIONS INC.

## SMA SUBSYSTEM TECHNOLOGY

Technology issues which resulted from the technology assessment effort are listed in the next two charts, along with the R&D efforts needed to resolve these issues. Identification of technology issues and R&D efforts needed for the module is broken down on the basis of the following components:

- Phased Array
- Phased Array Antenna Element
- Beam Forming Network.

Regarding the phased array, the technology issues are interbeam coupling (which produces interbeam interference) and the fact that the achieved gain is much less than theoretical limit. The resolution of these issues lies in the identification of adequate components with low losses and stable parameters, optimization of the array configuration, and improved implementation techniques to provide high performance assemblies.

The technology issue associated with the phased array element (which is a helix) is that the achieved gain is 1.5 dB less than that theoretically possible. The expected difference between the achieved gain and what is theoretically possible should be about 0.5 dB. This provides room for a 1 dB improvement in element gain. In the R&D needed, the plausible approaches to realize this improvement are listed.

SMA SUBSYSTEM TECHNOLOGY

ASSEMBLY

KEY COMPONENTS AND USE

CRITICAL TECHNOLOGY ISSUES

R&D NEEDED

SMA

PHASED ARRAY: ANTENNA TO PROVIDE SIMULTANEOUSLY MAX: 10 BEAMS AIMED AT 10 RESPECTIVE USER S/C IN A 26° CONICAL FOV.

- INTERBEAM COUPLING CAUSES INTERFERING SIGNAL ENTRIES INTO DESIRED BEAMS.
- ACHIEVED GAIN IS MUCH LOWER THAN THEORETICAL LIMIT

IDENTIFICATION OF

- ADEQUATE COMPONENTS
- ARRAY CONFIGURATION
- IMPLEMENTATION TECHNOLOGY

TO ASSURE

- HIGH INTERBEAM ISOLATION
- MINIMAL GAIN LOSS.

PHASED ARRAY ANTENNA ELEMENT

BASIC ANTENNA ELEMENT USED TO STRUCTURE THE PHASED ARRAY

- HELIX ANTENNA ELEMENTS YIELD GAIN WHICH IS 1.5 DB LESS THAN THEORETICALLY POSSIBLE

INVESTIGATE THE FOLLOWING APPROACHES TO IMPROVE ELEMENT GAIN BY ≈ 1 DB

- INCREASED CONDUCTIVITY OF HELIX CONDUCTOR
- REDUCE CABLE LOSSES
- IMPROVE IMPEDANCE MATCH BETWEEN ELEMENT AND CABLE
- DETERMINE OPTIMUM SHAPE OF TUBE THAT SUPPORTS HELIX
- IDENTIFICATION OF LESS LOSSY THERMAL PROTECTIVE PAINT AND SUPPORTING TAPE.



STANFORD  
TELECOMMUNICATIONS INC.

## SMA SUBSYSTEM TECHNOLOGY (CONTINUED)

Regarding the Beam Forming Network (BFN), the technology issues are the degradation in SMA G/T (Gain to temperature noise ratio) due to lossy components of the weighting subsystem, and the gain loss that occurs due to the nonuniformity of amplitude and phase versus frequency characteristics of the beam forming network. To avoid these gain losses, the return channel carrying the signals from phased array antenna elements has to be frequently calibrated so that the nonuniformity of amplitude and phase characteristics can be compensated. The technology issues can be settled by developing light and less lossy weighting components, by improving the transfer characteristics of beam forming networks, and by development of efficient beam forming algorithms.

SMA SUBSYSTEM TECHNOLOGY (CONT'D)

<u>ASSEMBLY</u>	<u>KEY COMPONENTS AND USE</u>	<u>CRITICAL TECHNOLOGY ISSUES</u>	<u>R&amp;D NEEDED</u>
SMA	<u>BEAMFORMING NETWORK (BFN)</u> PROVIDES APPROPRIATE WEIGHTING TO THE SIGNALS RECEIVED BY EACH PHASED ARRAY ANTENNA ELEMENT FROM USER S/C AND SYNTHESIZES THE BEAM POINTED AT USER S/C	<ul style="list-style-type: none"><li>● POWER LOSS IN WEIGHTING COMPONENTS CAUSES SMA G/T TO DEGRADE</li><li>● NONUNIFORMITY OF AMP: AND PHASE VS FREQ. CHARACTERISTICS OF BFN CAUSES GAIN LOSS AND REQUIRES ELABORATE CALIBRATION</li></ul>	DEVELOPMENT OF LOW LOSS AND LIGHT WT WEIGHTING COMPS.  DEVELOPMENT OF BFN WITH IMPROVED TRANSFER CHARACTERISTICS SO THAT <ul style="list-style-type: none"><li>- BF LOSSES ARE LESS</li><li>- LESS FREQUENT OR NO CALIBRATION IS NEEDED</li></ul>

VII-2-213



STANFORD  
TELECOMMUNICATIONS INC.



ADDITIONAL SMA UNIQUE R&D NEEDED

Based upon R&D needs identified during the technology assessment effort and related developments taking place elsewhere, the additional SMA unique development efforts that are necessary are documented.

ADDITIONAL SMA UNIQUE R&D NEEDED

DEVELOPMENT OF

- ENHANCED GAIN SMA HELIX ELEMENT
- $\mu$ P BASED ON BOARD BEAM FORMING PROCESSOR TO SATISFY STATED REQUIREMENTS
- LOW LOSS/LIGHT WEIGHT DIGITAL PHASE SHIFTERS FOR SMA ARRAY

VII-2-215



STANFORD  
TELECOMMUNICATIONS INC.

2.2.2

WSA TECHNOLOGY

The elements addressed in this section of the report are indicated.

## WSA TECHNOLOGY

- WSA MODULE REQUIREMENTS FOR TDAS
- FUNCTIONAL BLOCK DIAGRAM - WSA MODULE
- DESIGN ALTERNATIVES
  - ANTENNA
  - ANTENNA POINTING AND CONTROL PROCESSOR
- SUMMARY/CONCLUSIONS
- DISCRETE ANTENNA WSA MODULE TECHNOLOGY
  - CRITICAL TECHNOLOGY ISSUES
  - R&D NEEDED
- ADDITIONAL WSA UNIQUE R&D NEEDED



STANFORD  
TELECOMMUNICATIONS INC.

DISCRETE ANTENNA WSA MODULE REQUIREMENTS FOR TDAS

The requirements for the WSA (60 GHz Single Access) module for use on the TDAS S/C to enhance data relay capabilities with least burden on user S/C are listed.

DISCRETE ANTENNA WSA MODULE REQUIREMENTS FOR TDAS

FREQUENCY	60 GHZ
COMMUNICATION LINKS	TDRS-TO-USER S/C USER S/C-TO-TDRS
USER ACCOMODATION	5 RETURN 5 FORWARD
ANTENNA GAIN	$\geq 53$ DB
SYSTEM NOISE TEMP	$\leq 450^{\circ}$ K
POINTING ACCURACY	$\pm 0.1$ DEG.

VII-2-219



STANFORD  
TELECOMMUNICATIONS INC.

## FUNCTIONAL BLOCK DIAGRAM - WSA MODULE

A simplified functional block diagram of the WSA module is shown with its interfaces to the TDAS-to-Ground transmitter and the Ground-to-TDAS receiver. The module provides a capability for five (5) single accesses through five (5) individual parabolic antennas, each with its own dedicated Antenna Pointing and Control System (APCS). Both forward and return link single access service is provided through the same antenna. Each APCS has an associated processor which receives information necessary for computing the desired boresight direction and produces corresponding drive signals for precise orientation of the antenna. The return signals are routed to desired downlinks through the switch. There is a TDAS on-board computer (OBC) which performs various S/C functions and provides TDAS and user S/C orbital data support to the APCS systems.

# FUNCTIONAL BLOCK DIAGRAM - WSA MODULE

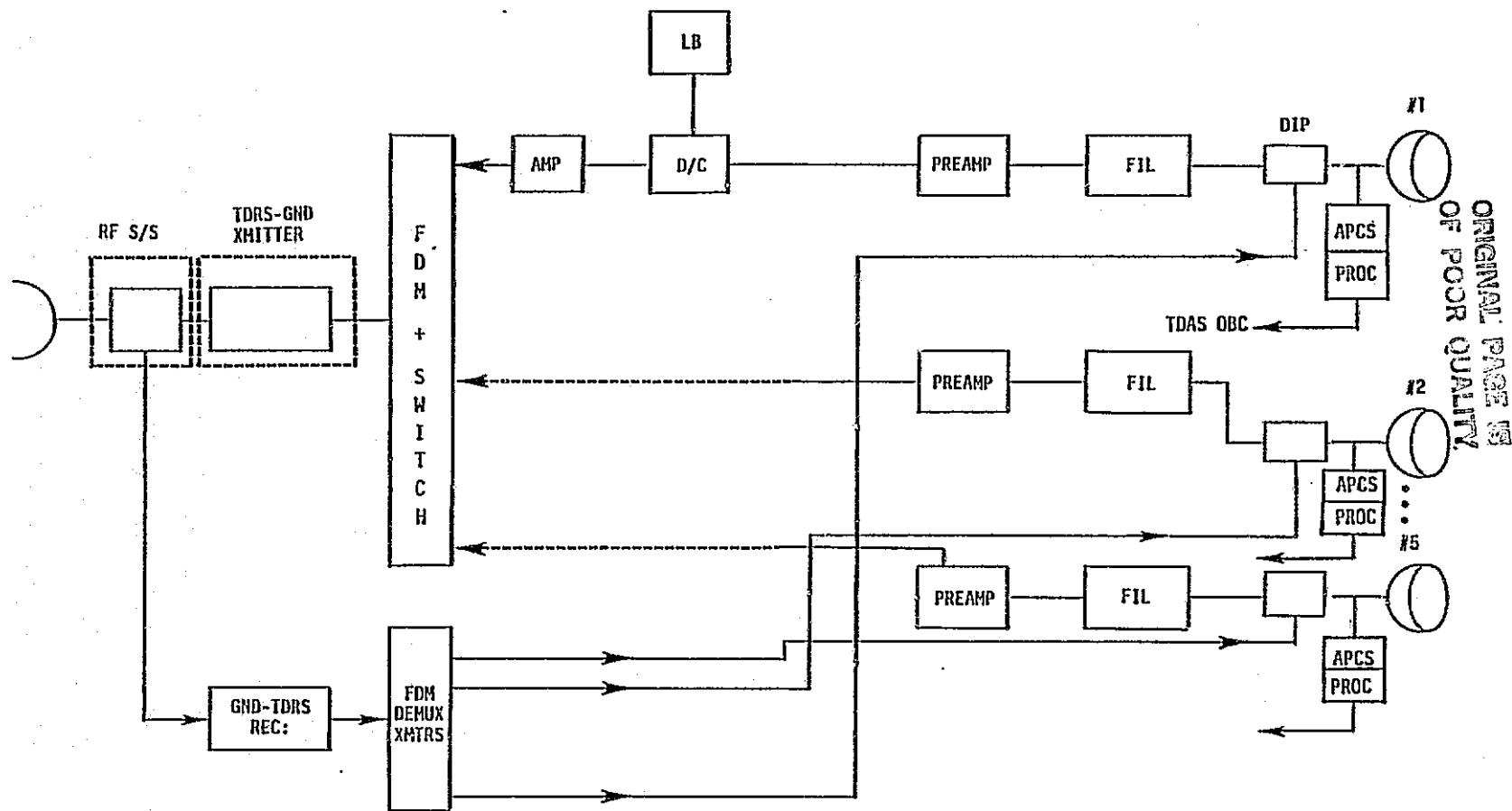

APCS: ANT: POINTING AND CONTROL SYSTEM  
 PROC: PROCESSOR  
 OBC: ON-BOARD COMPUTER

VII-2-221



**STANFORD  
 TELECOMMUNICATIONS INC.**



## ANTENNA CHARACTERISTICS

In the technology assessment effort, three candidate antennas which hold promise for the WSA module were addressed as follows:

- Gimbaled Parabolic Antenna
- Gimbaled Parabolic Antenna with subreflector scanning
- Phased Array Antenna
- Parabolic Antenna with Phased Array Feed.

The technology of these antennas was assessed on the basis of the following characteristics:

- Gain
- Data Relay Capability
- Acquisition/Tracking Subsystem Power Requirement
- Pointing Accuracy
- Complexity
- Reliability.

The nominal range of characteristics for Gimbaled Parabolic Antennas are tabulated in the chart.

## ANTENNA CHARACTERISTICS - GIMBALLED PARABOLIC

GAIN (DB)	DATA RATE CAPABILITY (MBPS)	ACQ/TRK POWER REGMT (W)	TORQUE NOISE (DEG RMS)	POINTING ACC: (DEG RMS)	COMPLEXITY	RELIABILITY
53-54	40-50	10-15	.03-.05	+ .06-.1	LOW	HIGH

ORIGINAL PAGE IS  
OF POOR QUALITY

VII-2-223



STANFORD  
TELECOMMUNICATIONS INC.

ANTENNA CHARACTERISTICS (CONTINUED)

The nominal range of characteristics for a Gimballed Parabolic Antenna with Subreflector Scanning is presented in the chart.

## ANTENNA CHARACTERISTICS - GIMBALLED PARABOLIC WITH SUBREF SCANNING

GAIN (DB)	DATA RATE CAPABILITY (MBPS)	ACQ/TRK POWER REGMT (W)	TORQUE NOISE (DEG RMS)	POINTING ACC: (DEG RMS)	COMPLEXITY	RELIABILITY
51-53	25-30	7-10	.01-.05	$\pm$ .1-.2	HIGH	LOW

VII-2-225



STANFORD  
TELECOMMUNICATIONS INC.

## ANTENNA CHARACTERISTICS (CONTINUED)

The nominal range of characteristics for a Phased Array Antenna is presented in the chart. For this antenna, the gain is 43 dB (which falls short of the requirement by 10 dB) due to constraining the number of phased array elements to 600 to limit complexity. In order to satisfy the gain requirement, a large number of elements would be required which would make the design quite complex. In the next chart, this matter is elaborated further.

## ANTENNA CHARACTERISTICS - PHASED ARRAY

GAIN (DB)	DATA RATE CAPABILITY (MBPS)	ACQ/TRK POWER REQMT (W)	TORQUE NOISE (DEG RMS)	POINTING ACC: (DEG RMS)	COMPLEXITY	RELIABILITY
43 <sup>*</sup> DB	5	4-6	NEGLIGIBLE	$\pm .1 - .2$	HIGH <sup>**</sup>	LOW

\* WHEN NUMBER OF ELEMENTS OF PHASED ARRAY IS LIMITED TO 600.

\*\* LARGE NUMBER OF ELEMENTS REQUIRED TO SATISFY GAIN REQUIREMENT.



STANFORD  
TELECOMMUNICATIONS INC.

### PHASED ARRAY PARAMETERS FOR WSA

In the chart, parameters are derived for a phased array antenna for the WSA module to satisfy the 53 dB gain requirement and to provide a field-of-view of 26 degrees, conical. Based upon the use of a  $2.5 \lambda \times 2.5 \lambda$  cross section horn as an element with a gain of 15 dB, the number of elements required to satisfy the gain requirement is 6000. A phased array antenna with such a large number of elements is not practical. A phased array with 600 elements and a 43 dB gain as previously discussed appears practical but incapable of meeting the gain requirement.

## PHASED ARRAY PARAMETERS FOR WSA

REQUIREMENTS:	GAIN	53 DB
	FIELD OF VIEW	± 26 DEG CONICAL
PHASES ARRAY PARAMETERS:	PHASED ARRAY ELEMENT (HORN) SECTION	$2.5\lambda \times 2.5\lambda$
	ELEMENT GAIN (50% EFF)	15 DB
	NUMBER OF ELEMENTS REQUIRED	6000

VII-2-229



STANFORD  
TELECOMMUNICATIONS INC.



## ANTENNA CHARACTERISTICS - PARABOLIC WITH PHASED ARRAY FEED

The nominal range of characteristics for a Parabolic Antenna with Phased Array Feed is listed. In this case also, the gain that can be achieved with a practically feasible design falls short of the requirement.. Gain losses due to the range blockage caused by the phased array feed are the cause. However, such a design has medium complexity and reliability.

## ANTENNA CHARACTERISTICS - PARABOLIC WITH PHASED ARRAY FEED

GAIN (DB)	DATA RATE CAPABILITY (MBPS)	ACQ/TRK POWER REQUIREMENT (M)	TORQUE NOISE	POINTING ACC. (DEG RMS)	COMPLEXITY	RELIABILITY
43-48*	5-15	4-6	NONE	+ .1-.2	MED	MED

\* PHASED ARRAY FEED CAUSES GAIN LOSS DUE TO BLOCKAGE.

VII-2-231



STANFORD  
TELECOMMUNICATIONS INC.

## ANTENNA DESIGN ALTERNATIVES

A summary comparison of antenna design alternatives on the basis of their characteristics as enumerated earlier is tabulated. From this comparison, the Gimballed Parabolic Antenna is identified to be optimum for satisfying the imposed requirements with least complexity and risk.

## ANTENNA DESIGN ALTERNATIVES

TYPE	GAIN	DATA RATE CAPABILITY	ACQ/TRK POWER REQMT	TORQUE NOISE	POINTING ACC.	COMPLEXITY	RELIABILITY
GIMBALLED PARABOLIC*	HIGH	HIGH	HIGH	HIGH	HIGH	LOW	HIGH
GIMBALLED PARABOLIC WITH SCANNABLE SUBREFLECTOR	LOW	LOW	MED	LOW	LOW	HIGH	LOW
PHASED ARRAY	LOW	LOW	LOW	NEGLIGIBLE	MED	HIGH	LOW
PARABOLIC WITH PHASED ARRAY FEED	LOW	LOW	LOW	NONE	MED	MED	MED

\* PREFERRED CHOICE: IS OPTIMUM FOR SATISFYING REQUIREMENTS WITH LEAST COMPLEXITY AND RISK.



STANFORD  
TELECOMMUNICATIONS INC.

## APCS PROCESSOR ALTERNATIVES

The Antenna Pointing and Control System (APCS) is an important component of the antenna system; two APCS alternatives are possible with attendant advantages and disadvantages. For these two alternatives, a Central Processor (TDAS S/C On-Board Computer) and a Dedicated Processor, the advantages and disadvantages are listed. Although the additional burden on the TDAS S/C On-Board Computer due to APCS could still be handled by the central processor, a dedicated processor appears necessary or highly desirable because of the listed advantages that it offers.

## APCS PROCESSOR ALTERNATIVES

<u>TYPE</u>	<u>ADV/DISADV (+)</u>
CENTRAL PROC. (TDAS OBC)	<ul style="list-style-type: none"><li>+ HANDLES OTHER S/C FUNCTIONS AND PROC. MAY NOT BE AVAILABLE WHEN NEEDED BY APC'S</li><li>+ PROC. MAY BE OVERBURDENED WHEN ALL FIVE APCS FUNCTIONS ARE INCLUDED</li><li>+ DEMANDS PLACED UPON PROC. BY APC'S MAY CONFLICT</li><li>+ CHECKING OUT ALL PROC. FUNCTIONS EARLY IN DESIGN PHASE NOT POSSIBLE</li></ul>
DEDICATED PROC.*	<p>PROVIDES AUTONOMOUS PROCESSING FOR EACH APCS</p> <p>HIGH PROCESSING SPEED AVAILABLE FOR FREQUENT ANTENNA POSITION UPDATES</p> <p>APCS PROC. FUNCTIONS CAN BE CHECKED OUT EARLY IN DESIGN PHASE</p>

\* DEDICATED PROCESSORS APPEAR NECESSARY.



STANFORD  
TELECOMMUNICATIONS INC.

SUMMARY/CONCLUSIONS

A summary and conclusions of the WSA technology assessment effort are listed.

## SUMMARY/CONCLUSIONS

- GIMBALLED PARABOLIC ANTENNA IS OPTIMUM CHOICE
- DEDICATED PROCESSORS SHOULD BE USED FOR ANTENNA POINTING AND CONTROL SYSTEM (APCS)
- APCS MUST BE AUGMENTED WITH AUTOTRACKER
- NO AREAS OF CONCERN ARE FORESEEN

VII-2-237



STANFORD  
TELECOMMUNICATIONS INC.



## DISCRETE ANTENNA WSA MODULE TECHNOLOGY

Technology issues which resulted from the technology assessment effort are listed in the next two charts, along with the R&D efforts needed to resolve these issues. Identification of the technology issues and the R&D efforts needed for the module is broken down on the basis of the following components:

- Antenna
- Antenna Pointing and Control System (APCS)
- Autotracker
- Processor
- Preamplifier
- HPA.

The technology issues that arise due to antenna are the gain degradation and the difficulty of getting a smooth reflector surface from light weight materials (which also provide low inertia antenna structures thus allowing rapid acquisition). The causes of antenna gain degradation are surface roughness, loss of electromagnetic energy at the reflector and feed surfaces, misalignment of antenna parts, distortion of feed and reflector structures and blockage of the main reflector. The R&D efforts needed to resolve antenna technology issues should be directed at achieving 1/64 cm RMS surface smoothness, light weight feed and reflector structures whose active surfaces (at which  $I^2R$  losses can take place) can be coated with highly conductive coatings. At the same time, the material should provide rigid and low inertia antenna structures.

## DISCRETE ANTENNA WSA MODULE TECHNOLOGY

### ASSEMBLY

### KEY COMPONENTS AND USE

### CRITICAL TECHNOLOGY ISSUES

### R&D NEEDED

WSA  
MODULE

ANTENNA PROVIDES READ TRANSMIT AND  
RECEIVE GAIN

GAIN DEGRADES DUE TO

- REFLECTOR SURFACE ROUGHNESS  
(REQUIREMENTS INCREASE WITH  
FREQUENCY; STRINGENT AT 60  
GHZ)
- $I^2R$  LOSSES IN SURFACE
- MISALIGNMENT OF ANTENNA PARTS

APERTURE ILLUMINATION AND GAIN  
DEGRADES DUE TO

- FEED SURFACE LOSS
- SHAPE DISTORTION
- BLOCKAGE

DIFFICULT TO GET SMOOTH REFLECTOR  
SURFACE FROM LIGHT/LOW INERTIA  
STRUCTURES WHICH ALLOW RAPID AC-  
QUISITION

NEED FOR HIGH GAIN @ 60 GHZ BUR-  
DENS APCS WITH

- STRINGENT POINTING ACCURACY  
REQUIREMENT
- FAST/PRECISE CONTROL SYSTEM

ANT. POINTING TORQUES GENERATED  
BY APCS INDUCE TORQUE NOISE IN  
TDRS AND DISTURB IT'S ATTITUDE

OPTIMUM AUTOTRACKER FOR 60 GHZ  
OPERATION HAS NEVER BEEN DEVEL-  
OPED

DEVELOPMENT OF ANTENNA  
HAVING:

- 1/64 cm RMS SURFACE  
SMOOTHNESS
- LIGHT WT FEED AND  
REFLECTOR WITH  
HIGHLY CONDUCTIVE  
COATING
- MATERIAL AND CONFI-  
GURATION TO PRODUCE  
RIGID/LOW INERTIA  
ANTENNA

ANTENNA POINTING/CONTROL SYS. (APCS)  
POINTS ANTENNA AT USER S/C

DEVELOPMENT OF

- PRECISION CONTROL  
SYS. CONFIGURATION
- PRECISION POSITION  
ENCODERS
- TECHNIQUES TO REDUCE  
TORQUE NOISE AND  
STIFFEN ACS.

AUTOTRACKER A COMPONENT OF APCS TO  
ENHANCE TRACKING EASE AND ACCURACY

DEVELOPMENT OF REQUIRED  
AUTOTRACKER

VII-2-239



STANFORD  
TELECOMMUNICATIONS INC.

DISCRETE ANTENNA WSA MODULE TECHNOLOGY (CONTINUED)

Regarding the APCS for the 60 GHz antenna, the technology issues arise due to limiting the loss of gain. Large antenna pointing errors will entail large gain losses and the same effects will be felt due to lack of control system precision. Another technology issue which originates from the APCS is the disturbance in TDAS attitude due to torque noise. Resolution of these technology issues required R&D efforts to develop precision control systems, precision position encoders and techniques to reduce torque noise and its impact.

An autotracker for 60 GHz has never been developed and built, and therefore the objective of the needed R&D effort is the development of such a unit.

DISCRETE ANTENNA WSA MODULE TECHNOLOGY (CONTINUED)

Regarding the processor, no unit is available or has been developed to meet the expected requirements. R&D efforts should be directed to develop microprocessor-based dedicated processors for precisely pointing the antenna.

For the preamplifier, the technology issue is the system noise temperature which exceeds the requirement. R&D efforts should be aimed at developing technology such that a system noise temperature of  $< 450^{\circ}\text{K}$  can be achieved.

The 60 GHz HPA related technology issue is the availability of only a limited amount of power from existing power sources. Resolution of this issue required boosting the power available using power combining; the needed R&D efforts must be aimed at development of low loss, and hence high efficiency, power combining techniques.

PRECEDING PAGE BLANK NOT FILMED

DISCRETE ANTENNA WSA MODULE TECHNOLOGY (CONT'D)

<u>ASSEMBLY</u>	<u>KEY COMPONENTS AND USE</u>	<u>CRITICAL TECHNOLOGY ISSUES</u>	<u>R&amp;D NEEDED</u>
WSA MODULE	PROCESSOR PERFORMS NECESSARY COMPUTATIONS FOR GENERATING ANT. DRIVE SIGNALS	NO PROCESSOR IS AVAILABLE TO MEET REQUIREMENTS	DEVELOPMENT OF AN ADEQUATE DEDICATED PROCESSOR USING SPACE QUALIFIED $\mu$ P
	<u>PREAMP:</u> RECEIVER FRONT END	CURRENT TECHNOLOGY STATUS PROVIDES SYSTEM NOISE TEMP. $\geq 450^\circ$ K	TECHNOLOGY DEVELOPMENT TO REDUCE NOISE TEMP IS DESIRABLE
	<u>HPA:</u> PROVIDES CARRIER POWER	LIMITED POWER AVAILABLE PER HPA NECESSITATES POWER COMBINING WITH ATTENDANT LOSSES	DEVELOPMENT OF LOW LOSS POWER COMBINING TECHNIQUES

VII-2-243



STANFORD  
TELECOMMUNICATIONS INC.

ADDITIONAL WSA UNIQUE R&D NEEDED

On the basis of R&D needs identified to resolve the technology issues and developments taking place in related areas, the additional WSA unique R&D needed is listed.

ADDITIONAL WSA UNIQUE R&D NEEDED

DEVELOPMENT OF:

- LOW INERTIA 1/64 CM RMS SMOOTH REFLECTOR
- 60 GHZ LOW LOSS FEED
- PRECISION APCS, AUTOTRACKER AND ASSOCIATED DEDICATED PROCESSOR
- PREAMP: WHICH PROVIDES SYSTEM NOISE TEMP < 450° K
- 60 GHZ LOW LOSS POWER COMBINING TECHNIQUES

VII-2-245



STANFORD  
TELECOMMUNICATIONS INC.

2.2.3

LASER COMMUNICATION SUBSYSTEM TECHNOLOGY

The elements addressed in this section of the report are indicated.



## LASER COMMUNICATION SUBSYSTEM TECHNOLOGY

- LASER COMM: S/S REQUIREMENTS FOR TDAS
- LASER COMM: FUNCTIONAL BLOCK DIAGRAM
- DESIGN ALTERNATIVES AND TECHNOLOGY OF KEY COMPONENTS
  - LASER
  - PUMP
  - ACQUISITION/TRACKING SUBSYSTEM
  - OPTICAL RECEIVER
  - COMMUNICATION ELECTRONICS
  - CRITICAL TECHNOLOGY ISSUES
  - R&D NEEDED
- ATTRACTIVE ALTERNATIVES
- ADDITIONAL LASER COMM: S/S UNIQUE R&D NEEDED
- SUMMARY/CONCLUSIONS



LASER COMMUNICATION SUBSYSTEM REQUIREMENTS FOR TDAS

The Laser Communication Subsystem requirements defined for TDAS applications are listed on this chart.

LASER COMM: S/S REQUIREMENTS FOR TDAS

COMMUNICATION LINKS: TDAS-TO-TDAS  
USER S/C-TO-TDAS

DATA RATE: TRANSMIT  
100 Kbps - 2 GBps  
RECEIVE  
2 GBps

LASER OUTPUT: > 300 mW

POINTING ACCURACY:  $\leq 1 \mu\text{RAD}$

ACQUISITION TIME: < 10 SEC

VII-2-249



STANFORD  
TELECOMMUNICATIONS INC.

LASER COMMUNICATION SUBSYSTEM FUNCTIONAL DESIGN  
(INDICATING TECHNOLOGY ITEMS)

The functional block diagram shows a representative design of Laser Communications Subsystem. The various blocks of the diagram indicate candidates for the technology items. The straight lines indicate RF paths, while the wavy lines indicate optical paths.

# LASER COMM: SUBSYSTEM FUNCTIONAL DESIGN (INDICATING TECHNOLOGY ITEMS)

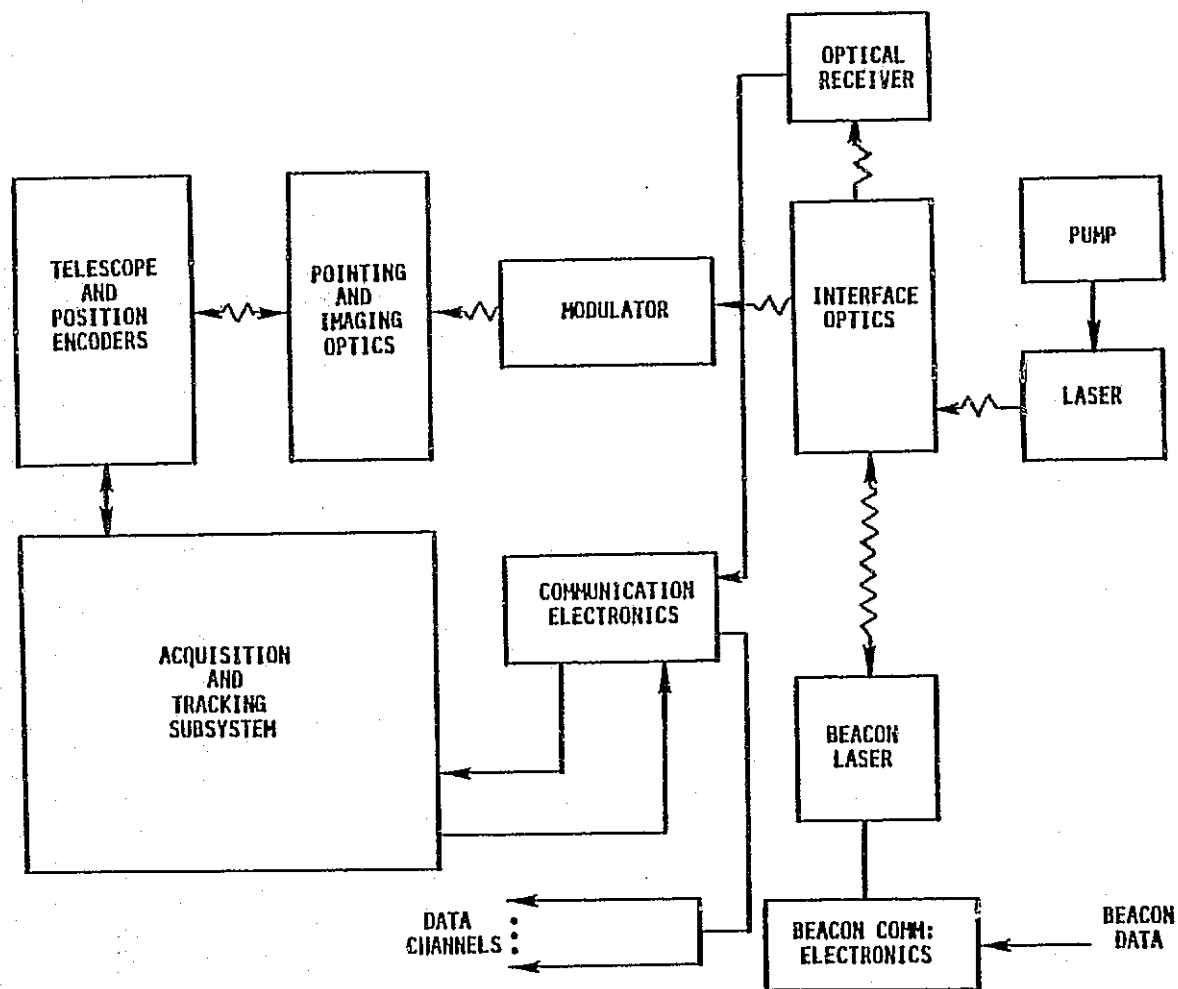

VII-2-251



**STANFORD  
TELECOMMUNICATIONS INC.**

## LASER CHOICES

The chart presents a list of choices of lasers in the frequency band extending from 0.5  $\mu\text{m}$  to 10.64  $\mu\text{m}$  for implementing the TDAS Laser Communications Subsystem. There are four choices: FD: NcYAG, GaAs, Nd YAG and CO<sub>2</sub> lasers. At a wavelength of 1.1  $\mu\text{m}$ , the indicated frequency band is divided into two halves. The key characteristics of the lasers which lie above and below this dividing wavelength are listed. The Significant characteristics of these four principal lasers from a System implementation viewpoint are laser oscillator efficiency, overall transmitter efficiency and life are quantified.

## LASER CHOICES

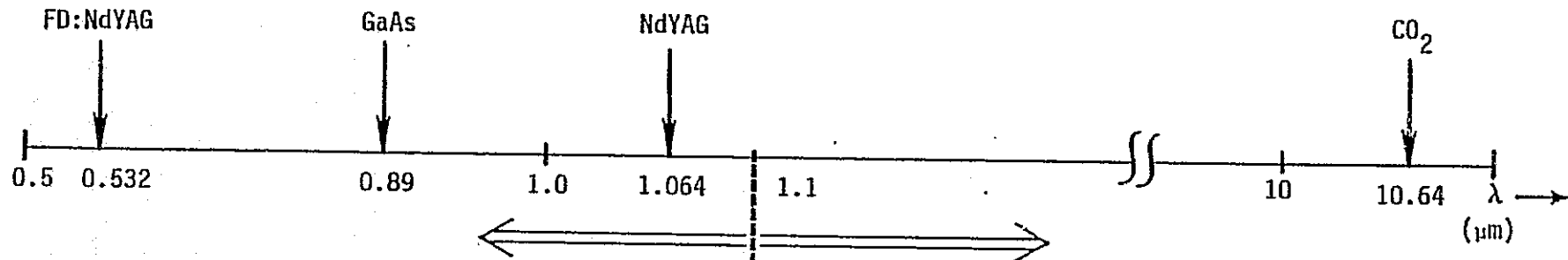

- $\lambda$  SMALLER ( $\gamma$  LARGER)
- $E = h\gamma$  LARGER
- ENERGY ASSOCIATED WITH A SIGNAL PHOTON IS LARGER.
  
- DIRECT DETECTION IS USED.

- $\lambda$  LARGER ( $\gamma$  SMALLER)
- $h\gamma$  SMALLER
- ENERGY ASSOCIATED WITH A SIGNAL PHOTON IS SMALL.
- SIGNAL PHOTONS TOO LOW IN ENERGY FOR THE WORK FUNCTION OF PHOTO-EMISSIVE DET. SURFACE.
- DETECTOR GAIN IS LOW AND FALLS OFF WITH A  $\lambda$ .
- HETERODYNE OR HOMODYNE DETECTION IS REQUIRED:
  - DETECTION IS "USUALLY" THERMAL NOISE LIMITED.
  - CONVERSION GAIN PROVIDED BY HETERODYNE DETECTION CAN MAKE DETECTION PROCESS SHOT NOISE LIMITED.

VII-2-253



**STANFORD  
TELECOMMUNICATIONS INC.**

## LASER CHOICES (CONT'D)

### CHARACTERISTICS OF PRINCIPAL LASERS

<u>LASER</u>	<u>WAVELENGTH (<math>\mu\text{m}</math>)</u>	<u>LASER OSCILLATOR EFFICIENCY (%)</u>	<u>OVERALL TRANSMITTER EFFICIENCY (%)</u>	<u>LIFE (HRS)</u>
FD: Nd YAG	0.532	0.8	0.4	>> 40,000
Nd YAG	1.06	0.5 - 1	0.5	>> 40,000
Ga As	0.89	5 - 10	1.0	$\approx 10^5$
CO <sub>2</sub>	10.6	10 - 15	0.7	< 40,000

PRECEDING PAGE BLANK NOT FILMED

VII-2-255



STANFORD  
TELECOMMUNICATIONS INC.



LASER COMMUNICATION SUBSYSTEM TECHNOLOGY COMPARISON  
ON THE BASIS OF CHOICE LASERS

Taking into account all key items from a communication System implementation viewpoint, the next two charts compare the technology of the two preferred choices, namely the FD: Nd YAG and GaAs lasers.

# LASER COMM: S/S TECHNOLOGY COMPARISON ON THE BASIS OF CHOICE LASERS

ITEM	LASER	
	FD: Nd YAG	GaAs
WAVELENGTH ( $\mu\text{m}$ )	0.532	0.85
FREQUENCY STABILITY	EMISSION LINE SHIFTS WITH AGE	IN THE COURSE OF LIFE TESTING SOME FREQUENCY SHIFTS HAVE BEEN NOTED
PUMP	REQUIRES PUMP (DIODE PUMP) - DIODE PUMPING REQUIRES MATCHING THE LASER EMISSION LINE TO A NARROW PUMP BAND - DIODE EMISSION LINE SHIFTS WITH AGE	
POWER COMBINING	SUFFICIENT POWER IS AVAILABLE FROM SINGLE Nd YAG ROD TO SATISFY COMM: LINK REQUIREMENTS NO POWER COMBINING NECESSARY	OUTPUT PER GaAs DIODE IS SMALL COMM: LINK FROM/TO TDAS WILL REQUIRE DIODE ARRAYS LEADING TO POWER COMBINING PROBLEMS
OVERALL TRANSMITTER EFFICIENCY	0.4%	1%

VII-2-257



**STANFORD TELECOMMUNICATIONS INC.**

LASER COMM: S/S TECHNOLOGY COMPARISON ON THE BASIS OF CHOICE LASERS (CONT'D)

ITEM	LASER	
	FD: Nd YAG	GaAs
MODULATION	WELL DEVELOPED MODULATION SCHEME FOR THIS LASER IS: - PULSE QUARternARY MODULATION (PQM) MODULATION EQUIPMENT IS FAIRLY ELABORATE	WELL DEVELOPED MODULATION SCHEME FOR THIS LASER IS: - PULSE POSITION MODULATION (PPM) - PULSE INTERVAL MODULATION (PIM) MODULATORS FOR GaAs DIODES ARE SIMPLE TO IMPLEMENT
DEMODULATION	OPTIMUM DETECTION SCHEME POSSIBLE	OPTIMUM DETECTION SCHEME POSSIBLE
LIFE	USE OF SOLID STATE COMPONENTS CAN PROVIDE 8-10 YEARS LIFETIME	LONG POTENTIAL LIFE

PRECEDING PAGE BLANK NOT FILMED

VII-2-259



STANFORD TELECOMMUNICATIONS INC.

## ALTERNATE DESIGN APPROACHES FOR ENHANCING POWER OUTPUT OF GaAs LASERS

An inherent deficiency of GaAs lasers is the limited output power available from a GaAs laser diode. To achieve sufficient power to satisfy TDAS communications requirements, the power output of GaAs lasers needs to be enhanced; various design approaches are possible. The next two charts list these approaches along with, brief descriptions and their advantages and disadvantages.

## ALTERNATE DESIGN APPROACHES FOR ENHANCING POWER OUTPUT OF GaAs LASERS

<u>APPROACH</u>	<u>DESCRIPTION</u>	<u>ADV/DISADV</u>
PARAMETER OPTIMIZATION	<p>THE PARAMETER (CROSS SECTION SHAPE OF THE ACTIVE REGION OF A SINGLE LASER DIODE) OPTIMIZATION RESULTS IN BETTER MODE SELECTION</p> <p>BY USING THIS APPROACH IT IS FEASIBLE TO OBTAIN DEVICES THAT MAINTAIN MODE BEHAVIOUR UP TO POWER LEVELS OF 100 mW</p>	POWER CAPABILITY FALLS SHORT OF FROM/TO TDAS COMMUNICATION LINK REQUIREMENTS.
PHASE LOCKING OF SEVERAL LASERS	THE OUTPUTS OF SEVERAL LASERS IS PHASE LOCK COMBINED BY PLACING THEM IN A COMMON EXTERNAL CAVITY	<p>ADV: THE POWER OUTPUTS OF INDIVIDUAL LASER DIODES CAN BE COHERENTLY COMBINED THUS PROVIDING A FINELY DEFINED RADIATION BEAM</p> <p>DISAD: APPROACH RELIES HEAVILY ON MECHANICAL STRUCTURES WHICH MAKE IT INHERENTLY LESS STABLE AND BULKY</p>
MONOLITHIC PHASE LOCKING (ONE DIMENSIONAL ARRAY)	IN THIS APPROACH ALSO, THE OUTPUT OF SEVERAL LASERS IS COHERENTLY COMBINED. HOWEVER, IN THIS SCHEME ALL THE LASERS ARE GROWN MONOLITHICALLY ON A COMMON SUBSTRATE AND PHASE LOCKING IS ACHIEVED BY OVERLAPPING THE EM FIELDS OF ADJACENT LASERS	<p>ADV: BECAUSE LASERS ARE OPERATED IN PARALLEL, NO EXTERNAL CAVITY IS NEEDED</p> <p>NOT BULKY</p> <p>UP TO 900 mW OF PEAK POWER IS POSSIBLE</p>



ALTERNATE DESIGN APPROACHED FOR ENHANCING POWER OUTPUT OF GaAs LASERS

<u>APPROACH</u>	<u>DESCRIPTION</u>	<u>ADV/DISADV</u>
MONOLITHIC PHASE LOCKING (TWO DIMENSIONAL ARRAY)	IN THIS APPROACH, EACH LASER DIODE IN PARALLEL MONOLITHIC ARRAY IS REPLACED BY EITHER <ul style="list-style-type: none"><li>- A VERTICAL COMBINATION OF SEVERAL DIODE LASERS</li></ul> OR <ul style="list-style-type: none"><li>- A DIODE LASER THAT CAN EMIT HIGH POWER LEVEL</li></ul>	<u>ADV:</u> POWER LEVEL $\geq$ 1000 mW ARE POSSIBLE  <u>DISADV:</u> THERE ARE POTENTIAL PRO- BLEMS IN DESIGN/FABRICATION <ul style="list-style-type: none"><li>- MAINTAINING THE UNIFORMITY OF EMITTED RADIATION PATTERN</li><li>- PRECISE AND STABLE COUPLING REQUIRED FOR LOCKING</li><li>- REMOVAL OF HEAT GENERATED WITHIN THE DEVICE STRUCTURE</li></ul>
OPTICAL COMBINING*	OUTPUTS OF MULTIPLE DIODES COMBINED USING PRINCIPLE INVERSE OF SPECTRUM SPLITTING BY PRISM.	DESIGN LESS CRITICAL



## LASER TRANSMITTER/PUMP SUBSYSTEM TECHNOLOGY

The chart lists critical technology issues related to the Laser Transmitter/Pump Subsystem and the corresponding R&D needed to resolve these issues. For such issues, the Transmitter/Pump Subsystem is investigated on the basis of the following components: laser diodes, Power Combiners, transmitter and the diode-pumped FD Nd:YAG laser. To resolve the identified technology issues the R&D needed constitutes an enhancement of Pulse Repetition Frequency (PRF) to GHZ, a decrease in Pulse Width (PW) to less than 1 ps, an increase in the lifetime, improved frequency stabilization, the development of efficient power combiners and enhanced power output.

## LASER TRANSMITTER/PUMP SUBSYSTEM TECHNOLOGY

<u>ASSEMBLY</u>	<u>KEY COMPONENTS AND USE</u>	<u>CRITICAL TECHNOLOGY ISSUES</u>	<u>R&amp;D NEEDED</u>
LASER TRANSMITTER/ PUMP ASSEMBLY	LASER POWERED BY PUMP IS THE SOURCE OF OPTI- CAL POWER FOR DATA TRANSMISSION FROM/TO TDAS	<p>LASER DIODES WHICH HAVE</p> <ul style="list-style-type: none"> <li>- HIGH POWER OUTPUT</li> <li>- INCREASED LIFETIME</li> <li>- INCREASED RELIABILITY</li> <li>- FREQUENCY STABILITY</li> </ul> <p>POWER COMBINERS</p> <ul style="list-style-type: none"> <li>- HIGH COMBINING EFF.</li> <li>- MONOLITHICALLY INTEGRATED HIGH POWER LASER</li> </ul> <p>TRANSMITTER</p> <ul style="list-style-type: none"> <li>- OPERATIONAL PRECISION OF OPTO-ELECTRONIC DEVICES</li> <li>- HIGH DATA RATE CAPABILITY</li> </ul> <p>DIODE PUMPED FD Nd: YAG LASER</p> <ul style="list-style-type: none"> <li>- OPTIMUM PUMP-COUPLING EFFICIENCY</li> <li>- FREQUENCY STABILITY</li> <li>- LIFE</li> </ul>	<p>ALTHOUGH CURRENT TECHNOLOGY R&amp;D PROGRAMS HAS FOLLOWING 1984 GOALS:</p> <ul style="list-style-type: none"> <li>- OUTPUT POWER = 500 mW (@ 532 AND 1060 nm)</li> <li>- PRF = <math>500 \times 10^6</math></li> <li>- PULSE WIDTH = 300 ps</li> </ul> <p>R&amp;D IS NEEDED TO</p> <ul style="list-style-type: none"> <li>- ENHANCE PRF TO 1 GHz</li> <li>- PW <math>\leq</math> ps</li> <li>- UNDERSTAND LIFE LIMITING MECHANISMS AND ACHIEVE 10 YEAR LIFE</li> <li>- DEVELOP SHUTTLE COMPATIBLE DESIGNS</li> <li>- UNDERSTAND AND CONTROL WAVE LENGTH SHIFTING</li> <li>- DEVELOP EFFICIENT POWER COMBINING METHODS TO GET HIGH LASER DIODE OUTPUT</li> <li>- DEVELOP SPACE QUALIFIABLE HIGH POWER LASER DIODES</li> </ul>

VII-2-265



ACQUISITION/TRACKING SUBSYSTEM ENVIRONMENT AND REQUIREMENTS

The chart defines the environment in which acquisition/tracking subsystem has to operate and lists the requirements imposed upon the Subsystem which are to be met in the defined environment.

## ACQUISITION/TRACKING SUBSYSTEM ENVIRONMENT AND REQUIREMENTS

### ENVIRONMENT

S/C STABILIZATION	3-AXIS
S/C ATTITUDE DETERMINATION ACCURACY	.01 DEG - 0.1 DEG
RANGE SEPARATION BETWEEN XMT. AND REC. LASERS	40 - 80 x 10 <sup>6</sup> METERS

### REQUIREMENTS

COARSE POINTING ACCURACY	10 - 100 μRAD
FINE POINTING ACCURACY	≤ 1 μRAD
LASER BEAM LINE-OF-SIGHT JITTER	0.2 μRAD (PEAK)
ACQUISITION TIME	< 10 SECS.
REACQUISITION TIME	0.5 SEC.



## ACQUISITION AND TRACKING PHASES

Laser Communications between two Spacecraft (TDAS/TDAS and user spacecraft/TDAS) can be maintained by adequately carrying out the acquisition/tracking function. The chart enumerates various phases of acquisition/tracking function and lists the desired objective of each.

## ACQUISITION AND TRACKING PHASES

### VARIOUS PHASES:

ACQUISITION	LASER COMMUNICATION SUBSYSTEM MUST FIRST <u>ACQUIRE</u> THE OPPOSITE S/C
TRACKING	AFTER ACQUISITION, IT MUST MAINTAIN CLOSED LOOP <u>TRACKING</u>
POINTING	DURING TRACKING, <u>POINTING</u> MUST BE MAINTAINED WITH HIGH ACCURACY
REACQUISITION	IF FOR ANY REASON TRACKING AND POINTING CONTROL LINK IS BROKEN, THE S/C MUST BE QUICKLY <u>REACQUIRED</u>

VII-2-269



STANFORD  
TELECOMMUNICATIONS INC.

## ACQUISITION/TRACKING GEOMETRY

In the figure, the acquisition/tracking geometry for two Satellite—borne Laser Communication Subsystems is illustrated. The Laser Subsystem (S/S) A is on Spacecraft (S/C)  $S_A$ , while Laser S/S B is on  $S/C^{SB}$ . The two S/C are Separated by distance  $R$ , and it is assumed that A is transmitting and B is receiving. The transmitting laser has a beacon while the receiving laser has a detector (DET).

Associated with each Spacecraft is an error volume. The error volume around the transmitting Laser A indicates the receiving laser B's assessment of the uncertainty about the beam of the beacon on laser A. Similarly the error volume around the receiving laser B indicates transmitting laser A's assessment of the uncertainty about the detector on laser B.

ACQUISITION/TRACKING GEOMETRY

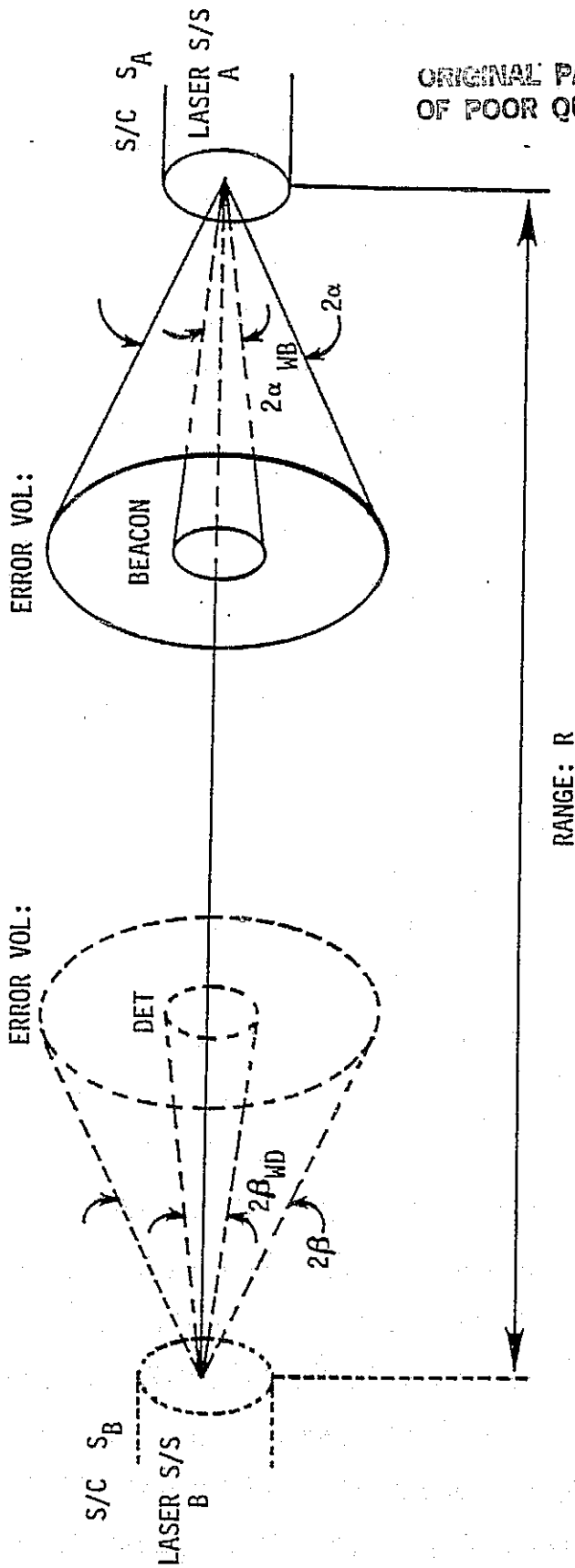

ORIGINAL PAGE IS  
OF POOR QUALITY

## DESIGN ALTERNATIVES FOR ACQUISITION

The next three charts list the progress of the acquisition process as a function of time and presents three Scanning alternatives that are candidates for the TDAS Acquisition/Tracking Subsystem Design. These alternatives are Raster Scan, along with the use of a high power beacon, and Square or Spiral Scan, along with the use of a low power beacon. For each case the acquisition process is summarized, and a preliminary assessment of feasible acquisition time and design complexity is listed. The Scanning patterns are illustrated in the third chart.

## DESIGN ALTERNATIVES FOR "ACQUISITION"

ACQUISITION BETWEEN LASER COMM:  
TERMINALS INITIATED BY OBC\*

↓  
TERMINAL ON  $S_A$  TURNS ON BEACON FOR TERMINAL  
ON  $S_B$  TO DETECT AND LOCK ON TO

↓  
 $S_B$  INITIATES "ACQUISITION" OF BEACON FROM  $S_A$

↓  
**DESIGN ALTERNATIVES FOR ACQUISITION**

HIGH POWER BEACON (WIDE BEAMWIDTH < ENTIRE  
ERROR VOL. WITH ADEQUATE  
EIRP POSSIBLE)

RASTER SCAN

LOS BETWEEN  $S_A$  AND  $S_B$   
BORESIGHTED

ACQUISITION ACHIEVED BY SEQUENTIALLY  
NARROWING ANGULAR FIELD OF POINTING  
UNCERTAINTY

LOW POWER BEACON (WIDE BEAMWIDTH < ENTIRE  
ERROR VOL. WITH ADEQUATE  
EIRP NOT POSSIBLE)

SQUARE SCAN

SAME

SPIRAL SCAN

SAME

ORIGINAL PAGE IS  
OF POOR QUALITY.



STANFORD  
TELECOMMUNICATIONS INC.

\* OBC: ON-BOARD COMPUTER.



REC. TERM. STARTS ACQUISITION BY SCANNING THE WIDE BEACON BEAM OVER THE ERROR VOL. OF TRANSMITTER

BEACON BEAM IS SENSED ON WIDE FOV DETECTOR WHICH DRIVES THE GIMBALLED MIRROR TO REDUCE THE BORESIGHT ERROR

WHEN BORESIGHT ERROR IS SMALL, NARROW FOV DETECTOR IS USED

REC. TERM. INITIALLY DIRECTS ENTIRE RECEIVED LASER POWER TO ACQ/TRK DET. AND CORRECTS POINTING ERRORS IN THE SCAN PATTERN

WHEN TRANSMITTER IS CENTERED IN THE FOV, REC STOPS SCANNING THE BEACON AND SWITCHES BEACON BEAMWIDTH USED FOR ACQUISITION TO THAT USED FOR TRACKING

WHEN POINTING ERROR AT THE REC. TERM. SATISFIES REQUIRED MUTUAL AUTOMATIC TRACKING CONDITIONS THE OPTICS TRANSFERS MAJORITY OF RECEIVED LASER SIGNAL TO HIGH DATA RATE OPTICAL DETECTOR

FEASIBLE ACQUISITION TIME:

≤ 5 SEC

DESIGN COMPLEXITY:

MED

S<sub>B</sub> RAPIDLY SEARCHES FOR THE BEACON EMITTED FROM S<sub>A</sub> AND S<sub>A</sub> SLOWLY SEARCHES WITH ITS BEACON FOR S<sub>B</sub>  
(LOCATIONS OF S<sub>A</sub> AND S<sub>B</sub> WITHIN THEIR ERROR VOLUMES ARE UNKNOWN)

SAME

≤ 10 SEC

LOW

≤ 2 SEC

HIGH  
(DUE TO COMPLICATED SCANNING CKTS)

PRECEDING PAGE BLANK NOT FILMED

VII-2-275



STANFORD  
TELECOMMUNICATIONS INC.

DESIGN ALTERNATIVES FOR ACQUISITION (CON'T)

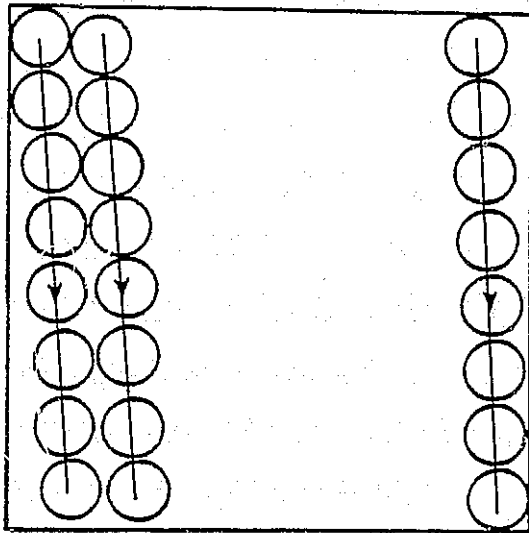

RASTER SCAN

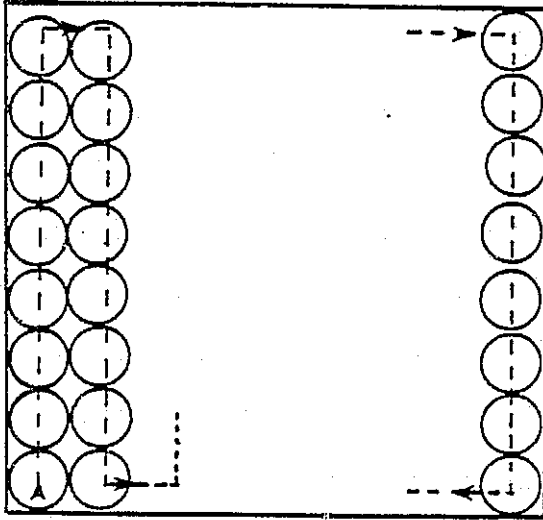

SQUARE SCAN

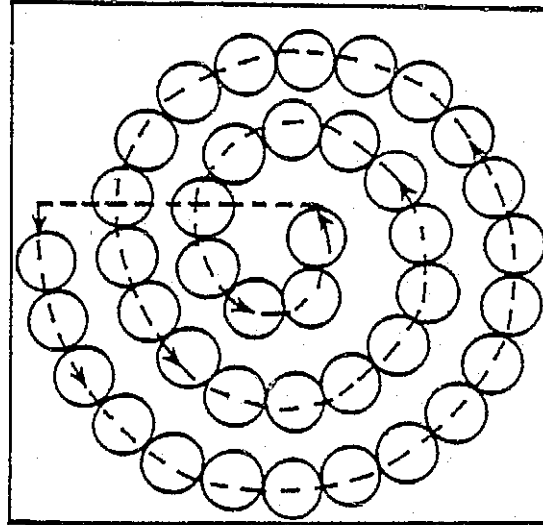

SPIRAL SCAN

ORIGINAL PAGE IS  
OF POOR QUALITY

ACQUISITION/TRACKING S/S FUNCTIONAL DIAGRAM  
(INDICATING TECHNOLOGY ITEMS)

The functional block diagram shows a representative design of a TDAS Acquisition/Tracking Subsystem and its interfaces with other Subsystems. Various blocks of this diagram indicate candidates for technology items. The straight lines indicate RF paths, while the wavy lines indicate optical paths.

**ACQUISITION/TRACKING S/S FUNCTIONAL DIAGRAM  
(INDICATING TECHNOLOGY ITEMS)**

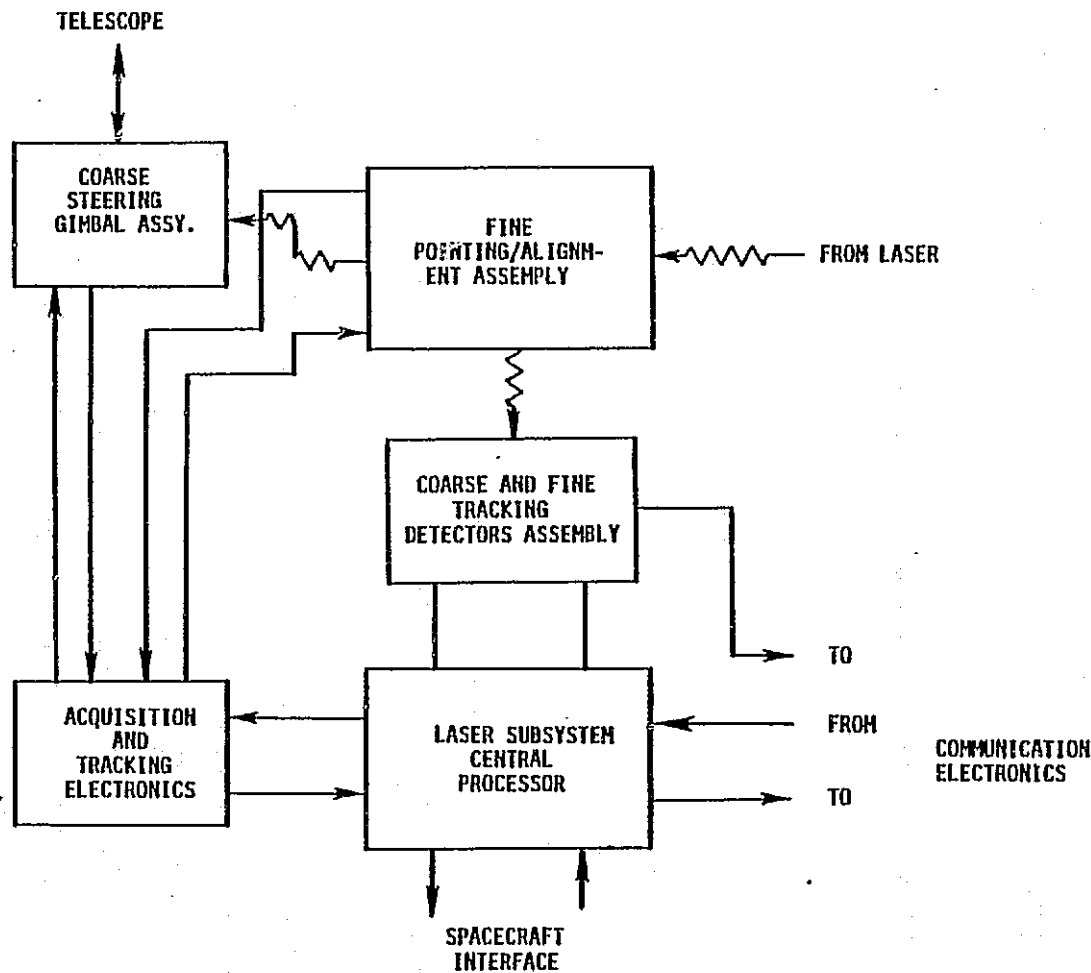

ORIGINAL PAGE IS  
OF POOR QUALITY

VII-2-279



STANFORD  
TELECOMMUNICATIONS INC.

## ACQUISITION/TRACKING SUBSYSTEM TECHNOLOGY

The next two charts list critical technology issues and R&D efforts needed to resolve these issues for realization of a compliant TDAS Acquisition/Tracking Subsystem. For this technology assessment effort, the Acquisition/Tracking Subsystem is subdivided into Coarse Steering Gimbal, Fine Pointing Control/Alignment, Coarse and Fine Detectors, Acquisition/Tracking Electronics Assemblies and Laser Subsystem Central Processor. For each assembly, the key components, their use, critical technology issues and R&D efforts needed are listed.

## ACQUISITION/TRACKING SUBSYSTEM TECHNOLOGY

<u>ASSEMBLY</u>	<u>KEY COMPONENTS AND USE</u>	<u>CRITICAL TECHNOLOGY ISSUES</u>	<u>R&amp;D NEEDED</u>
COARSE STERRING GIMBAL ASSEMBLY	CONSISTS OF 2 OR 3 AXES GIMBALLED TELESCOPE, GIMBAL ANGLE PICK-OFF SENSING DEVICES, GIMBAL SERVO DRIVE MOTORS AND RELAY OPTICS ASSEMBLY	NOISE INDUCED BY GIMBAL BEARING FRICTION AFFECTS LASER BEAM POINTING ACCURACY AND S/C ATTITUDE DETERMINATION AND CONTROL	GIMBAL BEARING FRICTION MUST BE REDUCED
FINE POINTING CONTROL/ ALIGNMENT ASSEMBLY	CONSISTS OF SEVERAL SETS OF GIMBALLED OPTICS WITH THEIR ASSOCIATED TORQUE MOTORS TO PERFORM FINE POINTING, LOOK-AHEAD COMPENSATION AND BORESIGHT ALIGNMENT	TO ACHIEVE PRECISION POINTING ACCURACY ON-BOARD BORESIGHT ALIGNMENT AND CALIBRATION ARE NECESSARY  TO PROVIDE ATTITUDE REFERENCE INFORMATION AND CONTROL JITTER HIGH PERFORMANCE GYROS ARE NEEDED	PRECISE ON-BOARD BORESIGHT ALIGNMENT TECHNIQUES  DEVELOPMENT OF PRECISION GYROS
COARSE AND FINE TRACKING DETECTORS ASSEMBLY	CONSISTS OF COARSE ACQUISITION DETECTOR HAVING A WIDE FOV TO PROVIDE ERROR SIGNALS FOR THE COARSE STEERING GIMBAL ASSEMBLY, FINE TRACKING DETECTOR HAVING A NARROW FOV TO PROVIDE TRACKING ERROR SIGNALS FOR FINE POINTING AND ALIGNMENT, A DATA PROCESSOR AND ASSOCIATED ELECTRONICS	S/N RATIO OF THE DETECTORS AND THEIR DATA PROCESSING RATES ARE CRITICAL IN ACHIEVING FINE POINTING ACCURACY	TECH: THAT PREVENTS S/N DEGRADATION DURING DET: FABRICATION.



STANFORD  
TELECOMMUNICATIONS INC.

## ACQUISITION/TRACKING SUBSYSTEM TECHNOLOGY (CONT'D)

<u>ASSEMBLY</u>	<u>KEY COMPONENTS AND USE</u>	<u>CRITICAL TECHNOLOGY ISSUES</u>	<u>R&amp;D NEEDED</u>
ACQUISITION/TRACKING ELECTRONICS ASSEMBLY	<p>THIS ASSEMBLY IS THE BRAIN REQUIRED TO PERFORM THE LASER S/S</p> <ul style="list-style-type: none"> <li>- ACQUISITION</li> <li>- REACQUISITION</li> <li>- POINTING, AND</li> <li>- TRACKING</li> </ul>	<p>IT IS DESIRABLE FROM WT/POWER/REL ASPECTS TO HANDLE SOFTWARE FUNCTIONS BY A COMMON PROCESSOR</p>	<p>DEVELOPMENT OF COMMON PROCESSOR</p>
LASER S/S CENTRAL PROCESSOR	<p>FUNCTIONS. INFO PROVIDED BY THE CENTRAL PROCESSOR AND TRACKING DETECTORS COMMAND THE COARSE STEERING GIMBAL ASSEMBLY AND FINE POINTING/ALIGNMENT ASSEMBLY TO PERFORM THE ABOVE FUNCTIONS</p> <p>CENTRAL PROCESSOR SERVES AS THE INTERFACE BETWEEN THE S/C AND THE LASER S/S. ITS MAJOR FUNCTIONS ARE TO ACHIEVE</p> <ul style="list-style-type: none"> <li>- S/C ATTITUDE DETERMINATION AND CONTROL</li> <li>- HANDLING S/C EPHEMERIS INFO.</li> <li>- ACQUISITION</li> <li>- TRACKING</li> <li>- POINTING</li> <li>- COMMAND</li> <li>- TELEMETRY</li> </ul>	<p>PROCESSOR TECHNOLOGY</p>	<p>PROCESSOR DESIGN TECHNOLOGY IS WELL DEVELOPED. NO PROBLEMS ARE ENVISIONED</p>

PRECEDING PAGE BLANK NOT FILMED



**STANFORD TELECOMMUNICATIONS INC.**

## OPTICAL RECEIVER ALTERNATIVES FOR LASER COMMUNICATION SYSTEM DESIGN

The chart lists the design alternatives for the Laser, Detection Technique and the Detector from the viewpoint of implementing the receiver of a laser communication Subsystem. For the various candidates for these components, the most promising choices are listed.



## OPTICAL RECEIVER ALTERNATES FOR LASER COMMUNICATION SYSTEM DESIGN

### KEY ITEM/TECHNIQUE

### CANDIDATES

### CHOICE(S)

LASER

FD: Nd YAG, GaAs, Nd YAG, Co<sub>2</sub>

FD: Nd YAG, GaAs

DETECTION  
TECHNIQUE

HETRODYNE DET  
HOMODYNE DET  
DIRECT DET

DIRECT DET

DETECTOR

DYNAMIC CROSS FIELD PHOTOMULTIPLIER (DCFP)  
AVALANCE PHOTO DIODE (APD)  
HETROSTRUCTURE AVALANCE PHOTO DIODE (HAPD)

III TO V ALLOY HETEROSTRUCTURE  
PHOTO DIODE

VII-2-285



STANFORD  
TELECOMMUNICATIONS INC.

OPTICAL RECEIVER ALTERNATES FOR LASER COMMUNICATION SYSTEM (CONT'D)

CHARACTERISTICS OF PRINCIPAL DETECTORS

The chart lists principal detectors and their characteristics and a comparative evaluation. The Heterostructure Avalance Photo Diode Detector (HAPD) appears to be the most attractive candidate but needs development for Satellite applications.

OPTICAL RECEIVER ALTERNATES FOR LASER COMMUNICATION SYSTEM DESIGN (CONT'D)  
CHARACTERISTICS OF PRINCIPAL DETECTORS

DETECTOR

CHARACTERISTICS

DYNAMIC CROSSFILED PHOTOMULTIPLIER  
(DCFP)

BULKY  
SUFFERS FROM LIFETIME PROBLEM  
SUITABLE FOR HIGH DATA RATES

AVALANCE PHOTO DIODE  
(APD)

COMPARED WITH DCFP IT OFFERS  
- SPACE SAVING  
- WEIGHT SAVING  
- REDUCED POWER REQUIREMENTS

HETEROSTRUCTURE AVALANCHE PHOTO DIODE  
(HAPD)

COMPARED WITH DCFP  
- CURRENT APD DETECTORS ARE INFERIOR FOR  
HIGH DATA RATE APPLICATIONS

THESE ARE ATTRACTIVE CANDIDATES  
- FAST RESPONSE TIME (< 30 ps RISE TIME)  
- SUITABLE FOR HIGH DATA RATES  
- HIGH QUANTUM EFFICIENCY (95% @ 0.53  $\mu\text{m}$ )  
- USABLE IN 0.4 TO 1.8  $\mu\text{m}$  WAVELENGTH BAND  
BUT NEED DEVELOPMENT FOR S/C APPLICATIONS



STANFORD  
TELECOMMUNICATIONS INC.

COMMUNICATION ELECTRONICS SUBSYSTEM FUNCTIONAL DIAGRAM  
(INDICATING TECHNOLOGY ITEMS)

The functional block diagram shows a representative design of a communications Electronics Subsystem for a Laser Communication Subsystem and its interfaces with other Subsystems. The various blocks of this diagram indicate candidates for the technology items which are discussed later.

**COMMUNICATION ELECTRONICS SUBSYSTEM FUNCTIONAL DIAGRAM  
(INDICATING TECHNOLOGY ITEMS)**

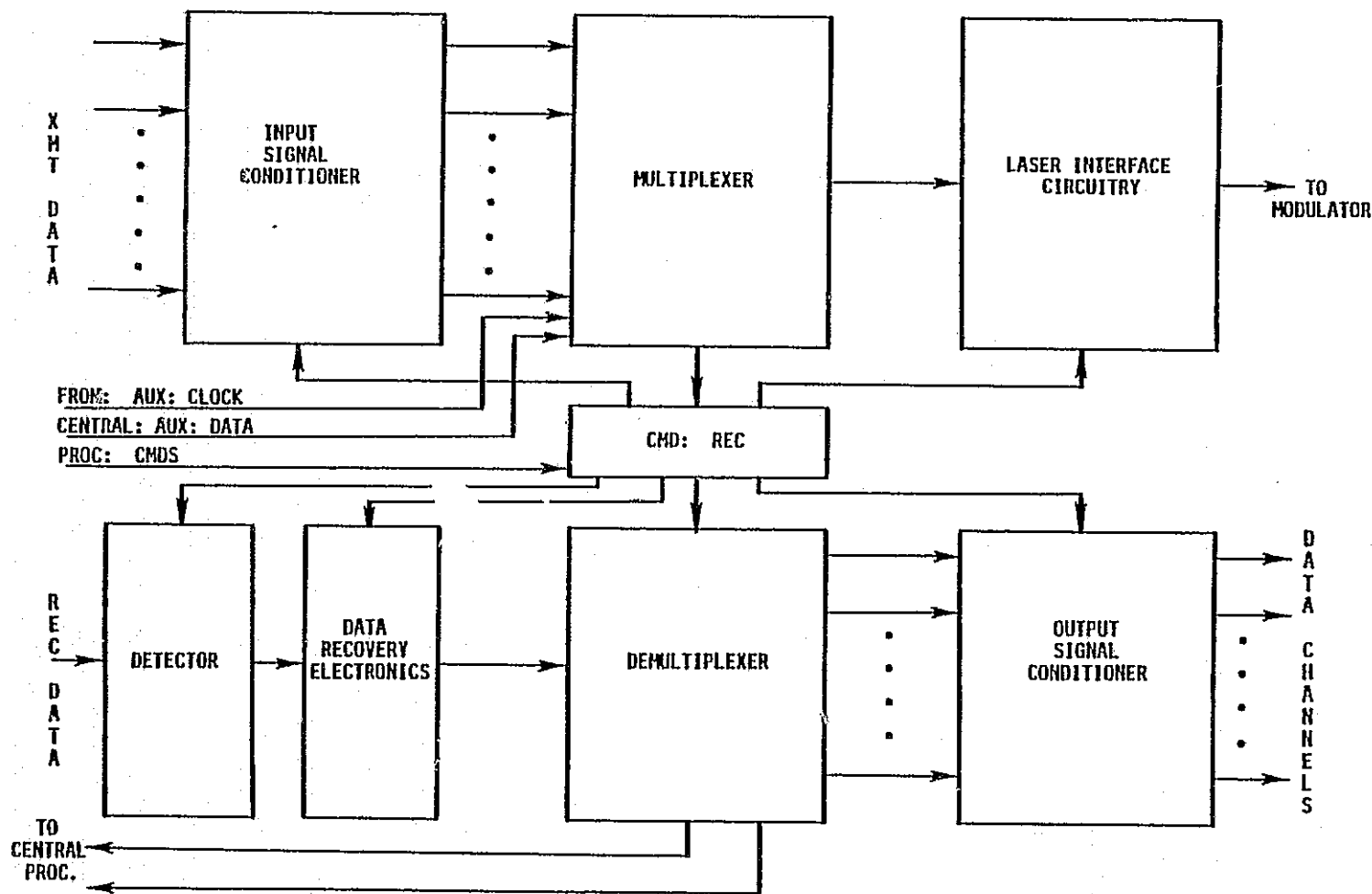

VII-2-289



**STANFORD  
TELECOMMUNICATIONS INC.**

## COMMUNICATION ELECTRONICS SUBSYSTEM TECHNOLOGY

The chart identifies the critical technology issues and the R&D efforts needed for a communication Electronics Subsystem of a Laser Communication System. This electronics Subsystem consists of two parts: The Receiver Electronics and the Transmitter Electronics. The critical technology issues and the R&D efforts needed for their resolution to enable TDAS implementation are listed on the basis of the key components of these two parts.

## COMMUNICATION ELECTRONICS SUBSYSTEM TECHNOLOGY

<u>ASSEMBLY</u>	<u>KEY COMPONENTS AND USE</u>	<u>CRITICAL TECHNOLOGY ISSUES</u>	<u>R&amp;D NEEDED</u>
TRANSMITTER ELECTRONICS	<p>CONSISTS OF THE FOLLOWING COMPONENTS</p> <ul style="list-style-type: none"><li>- INPUT SIGNAL CONDITIONER</li><li>- MULTIPLEXER</li><li>- LASER INTERFACE CIRCUITRY</li></ul> <p>INPUT SIGNAL CONDITIONER PRESCALES AND SAMPLES THE SIGNAL, ENSUING DATA IS MULTIPLEXED BY A HIGH SPEED MULTIPLEXER ALONG WITH HOUSEKEEPING, TELEMETRY AND RANGE DATA. LASER INTERFACE CIRCUITRY PROVIDES PRECISION RETIMING (DERIVED FROM LASER PULSES) FOR THE MUXED DATA AND MUX CLOCKS PHASE LOCKED TO THE LASER MASTER CLOCK.</p>	<p>HIGH DATA RATE MUX AND DEMUX WHICH CAN PERFORM AS DESIRED WHEN A RANGE OF DATA RATES ARE INVOLVED WITH AGGREGATE DATA RATE <math>\approx</math> 1 GBPS</p> <p>ELECTRONIC CIRCUITRY PROVIDING NON-PRECISE CLOCK AND RETIMING LIMITS DATA RATE CAPABILITY</p> <p>DESIGN TECHNIQUES AND TECHNOLOGY TO ASSURE DATA INTEGRITY</p>	<p>ARCHITECTURAL CONFIGURATION AND DESIGN OF MUX/DEMUX SUITABLE FOR HANDLING 1 GBPS DATA IN SPACEBORNE ENV.</p> <p>INVESTAGATE HIGHER ORDER PHASE LOCKED LOOPS AND THE EFFECT OF PHASE NOISE TO ACHIEVE REQUIRED CLOCK/TIMING PRECISION</p>
RECEIVER ELECTRONICS	<p>CONSISTS OF THE FOLLOWING COMPONENTS</p> <ul style="list-style-type: none"><li>- DETECTOR INTERFACE</li><li>- DATA RECOVERY UNIT (DRU)</li><li>- DEMUX</li></ul> <p>DETECTOR INTERFACE IS THE ELECTRONIC PORTION WHICH INTERFACES WITH THE OPTICAL PORTION OF THE RECEIVER. DRU AGC AMPLIFIES OPTICAL DETECTOR OUTPUT DEMODULATES AND REGENERATES THE DATA STREAM. DEMUX SEPARATES DATA CHANNELS, REMOVES STUFF BITS, SMOOTHS DATA AND DEMUXES OVERHEAD DATA</p>		



STANFORD  
TELECOMMUNICATIONS INC.

## ATTRACTIVE ALTERNATIVES

As a result of the Laser Communication System technology assessment effort, some attractive alternatives have emerged for System implementation. These are listed in the chart.



## ATTRACTIVE ALTERNATIVES

- USE OF GaAs LASERS
- USE OF OPTICAL POWER COMBINING METHODS TO ENHANCE GaAs LASER OUTPUT.
- EMPLOY PULSE MODULATION AND DIRECT DETECTION
- LOW POWER BEACON, SQUARE SCAN ACQUISITION S/S DESIGN
- USE OF ALLOY HETEROSTRUCTURE PHOTO DIODE DETECTOR.

VII-2-293



STANFORD  
TELECOMMUNICATIONS INC.

ADDITIONAL LASER COMMUNICATION S/S UNIQUE R&D NEEDED

Based upon the R&D needs identified in the technology assessment effort and relevant developments taking place elsewhere in the NASA and industrial sectors, the additional Laser Communication S/S unique R&D efforts needed for realizing TDAS are listed.

ADDITIONAL LASER COMM: S/S UNIQUE R & D NEEDED

DEVELOPMENT OF:

- GaAS LASERS WITH INCREASED OUTPUT AND FREQ: STABILITY
- OPTICAL POWER COMBINING TECHNOLOGY WITH HIGH MECHANICAL STABILITY FOR TDAS USE
- LOW POWER BEACON ACQ/TRK S/S AND ASSOCIATED PROCESSOR
- ALLOY HETEROSTRUCTURE PHOTO DIODE DETECTORS



STANFORD  
TELECOMMUNICATIONS INC.

SUMMARY/CONCLUSIONS

A summary of the results and conclusions resulting from the Laser Communication System technology assessment effort are listed on the chart.

## SUMMARY/CONCLUSIONS

- LASER COMM: SYSTEMS FOR SPACE USE FEASIBLE
- LASER LINKS WILL SIGNIFICANTLY ENHANCE TDAS CAPABILITIES
- HIGH EFFICIENCY LASERS POSSIBLE
- ALLOY HETEROSTRUCTURE DETECTORS SHOW PROMISE OF HIGH PERFORMANCE

VII-2-297



STANFORD  
TELECOMMUNICATIONS INC.

2.2.4

SWITCH TECHNOLOGY

The elements addressed in this section of the report are identified.

## SWITCH TECHNOLOGY

- SWITCH REQUIREMENTS FOR TDAS
- FUNCTIONAL BLOCK DIAGRAM
- DESIGN ALTERNATIVES
- SUMMARY/CONCLUSIONS
- SWITCH MATRIX TECHNOLOGY
  - CRITICAL TECHNOLOGY ISSUES
  - R&D NEEDED
- ADDITIONAL SWITCH UNIQUE R&D NEEDED



## SWITCH REQUIREMENTS FOR TDAS

The requirements of the switch to be provided on the TDAS S/C to route any of N input signals (coming from TDAS user S/C) to any of M output signals corresponding to M locations on the ground are listed in the chart.

The switch dimensions are derived on the basis of accepting nominally thirty (30) inputs and providing return signals to nine (9) ground locations. Although it is not a hard requirement, it is desirable to examine the possibility of 2-way switch operation with the role of M and N reversed. The switch is required to operate at an Intermediate Frequency (IF) band, and the bandwidth capability is required to be in excess of 1 GHz.



## SWITCH REQUIREMENTS FOR TDAS

- DIMENSIONS: N - INPUTS,  $N \geq 30$   
M - OUTPUTS,  $M \geq 9$
- DIRECTIONALITY: ONE WAY N X M  
(POSSIBLY) TWO WAY M X N
- OPERATIONAL FREQUENCY: IF
- BANDWIDTH: > 1 GHz

VII-2-301



STANFORD  
TELECOMMUNICATIONS INC.

## BASIC SYSTEM DIAGRAM

A simplified basic system diagram incorporating the switch is shown. There are N inputs coming into the switch and M outputs routed by the switch to the Multiple Beam Antenna (MBA) through the RF subsystems after upconversion to the desired operational frequency for the TDAS satellite-to-ground transmission. (The input signals to the switch are assumed to be downconverted to IF.) The upconverters are necessary because the switch works at IF. The traffic routing is controlled by the Distribution Control Unit (switch intelligence and Control).

BASIC SYSTEM DIAGRAM

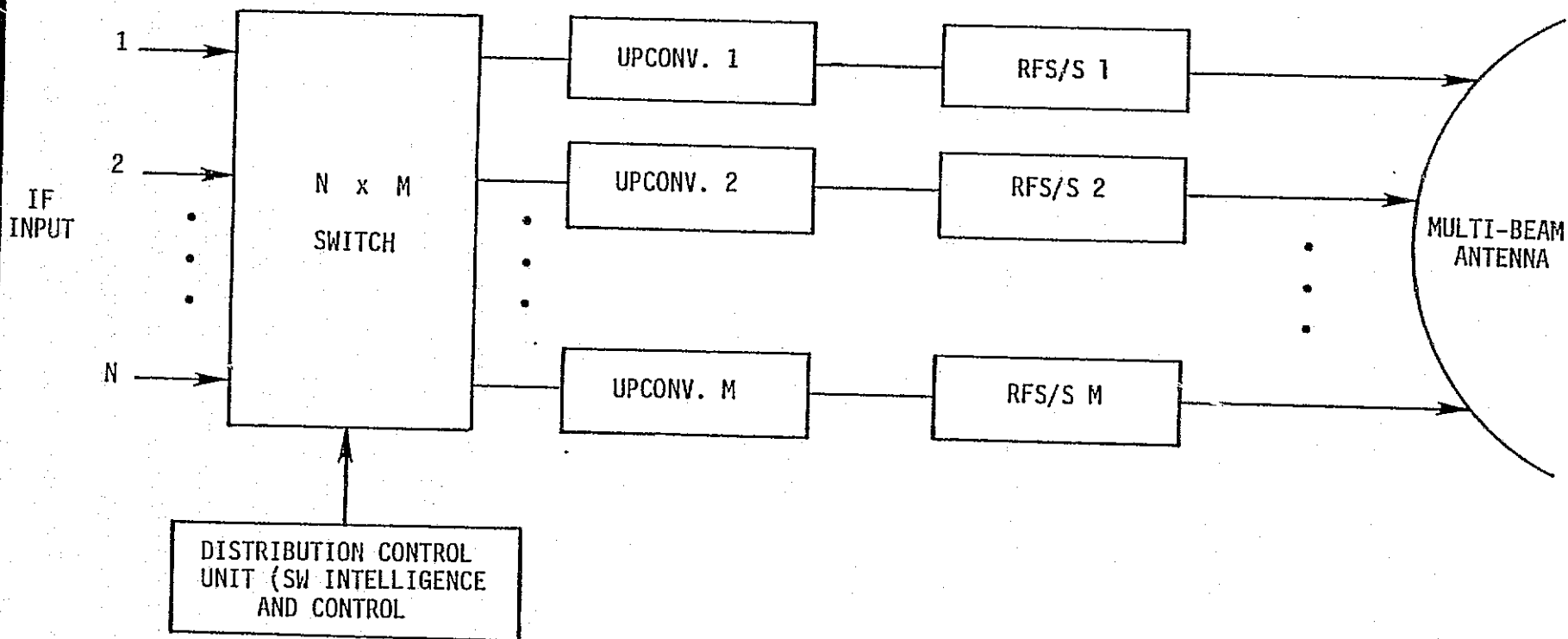

VII-2-303



STANFORD  
TELECOMMUNICATIONS INC.

## ALTERNATE SWITCH MATRIX ARCHITECTURES

In the technology assessment effort, four (4) alternate switch matrix architectures were considered, namely:

- Single pole multiple throw
- Rearrangeable switch
- Fan out/fan in
- Coupler crossbar.

The advantages and disadvantages of each of these architectures were considered; a comparison of these is listed. On the basis of this comparison, the coupler crossbar architecture is identified to be the preferred choice. (These four choices were considered because the NASA sponsored work which is referenced, identified them as the viable alternatives.)

## ALTERNATE SWITCH MATRIX ARCHITECTURES

<u>TYPE</u>	<u>ADVANTAGES</u>	<u>DISADVANTAGES</u>
SINGLE POLE MULTIPLE THROW	LOW INSERTION LOSS	POOR RELIABILITY
REARRANGEABLE SWITCH	LOW INSERTION LOSS LESS SWITCHES NEEDED	POOR RELIABILITY CONTROL ALGORITHM COMPLICATED
FAN OUT/FAN IN	RELIABLE	HIGH INSERTION LOSS HIGH INPUT VSWR
COUPLER CROSS/BAR*	COMPACT RELIABLE  LOW INSERTION LOSS POSSIBLE LOW VSWR LEAST SIZE/WEIGHT	LOW ISOLATION BROADBAND ( $\approx 2.5$ GHZ) COUPLERS REQUIRE DEVELOPMENT

\* PREFERRED CHOICE.

REF: SPACECRAFT IF SWITCH MATRIX FOR WIDEBAND SERVICE APPLICATIONS IN 30/20 GHZ COMMUNICATION  
SATELLITE SYSTEMS.

INTERIM TASK I REPORT: CONTRACT NO. NAS3-22501 NAS/LEWIS RESEARCH CENTER.



STANFORD  
TELECOMMUNICATIONS INC.

### COUPLER CROSSBAR SWITCH

A simplified functional diagram of the coupler crossbar switch, based upon the architecture identified to be the preferred choice, is shown. The switch contains a switching device at each crosspoint; the switching devices are designated by SW with associated numerals which identify the crosspoint. For example, the numeral 12 in SW12 identifies the switching element at the crosspoint of Input #1 and Output #2. If Input #1 is to be routed to Output #2, the switching element SW12 will be closed, thus providing a signal routing path from Input #1 to Output #2.

ORIGINAL PAGE IS  
OF POOR QUALITY

COUPLER CROSSBAR SWITCH

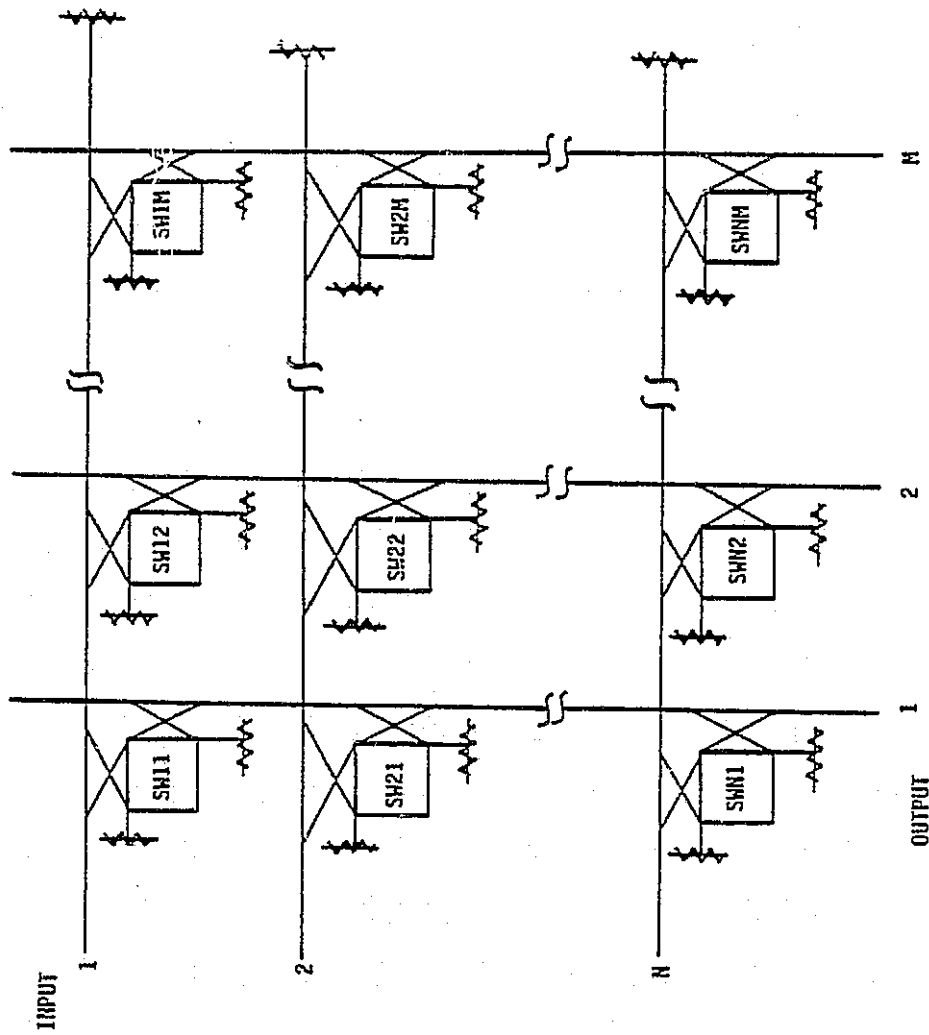

## CROSSBAR SWITCH DESCRIPTION

An overall description of the crossbar switch is listed in the chart. It includes the highlights of the architecture, the manner in which switching elements and couplers at each crosspoint act to establish a routing path through the switch, and an identification of the feature that a signal on any input line can be simultaneously connected to any number of output lines with no change in the output power level.



## CROSS-BAR SWITCH DESCRIPTION

- PROVIDES SWITCHING OF N TDAS SIGNALS TO M MBA BEAMS (SWITCHING OF M UPLINK SIGNALS TO N TDAS OUTPUTS IN CASE OF 2-WAY SWITCH)
- WORKS AT INTERMEDIATE FREQUENCIES
- CROSS-BAR ARCHITECTURE HAS INPUT AND OUTPUT TRANSMISSION LINES FORMING A MATRIX WITH N X M CROSS-POINTS
- AT EACH CROSS-POINT THERE IS ONE APPROPRIATE SWITCHING DEVICE FOR 1-WAY/2-WAY DESIGN
- DUAL GATE GaAs MESFET SWITCHING DEVICE PERFORMS SWITCHING AT THE SAME TIME PROVIDES GAIN
- IF AT A CROSS-POINT, SWITCH IS CLOSED, THE COUPLED SIGNAL IS AMPLIFIED AND THRU A SECOND DIRECTIONAL COUPLER COUPLED TO CORRESPONDING OUTPUT TRANSMISSION LINK
- IF AT A CROSS POINT, SWITCH IS OPEN, THE SIGNAL IS REFLECTED INTO THE LOAD AT THE OTHER END OF THE FIRST COUPLER AND IS NOT COUPLED TO THE OUTPUT LINK
- THE TWO COUPLING COEFFICIENTS OF INPUT AND OUTPUT COUPLERS ARE ADJUSTED SUCH THAT THE POWER AT THE INPUT TO DUAL GATE MESFET IS CONSTANT FOR ALL CROSS-POINTS
- BECAUSE OF THE ADJUSTMENT OF COUPLING COEFFICIENTS OF OUTPUT COUPLERS, THE POWER AT THE OUTPUT PORTS OF THE MATRIX IS ALSO CONSTANT
- INSERTION LOSS OF THE MATRIX IS CONSTANT AND INDEPENDENT OF THE CONNECTION PATH
- SIGNAL ON THE INPUT LINE CAN BE SIMULTANEOUSLY CONNECTED TO ANY NUMBER OF OUTPUT LINES WITH NO CHANGE IN THE OUTPUT POWER LEVEL
- AT EACH CROSS POINT, SAME AMOUNT OF IF POWER IS EXTRACTED FROM INPUT AND TRANSMITTED TO THE SWITCHING ELEMENT IRRESPECTIVE OF SWITCH STATUS (ON OR OFF)
- WHEN "ON" SIGNAL IS AMPLIFIED AND TRANSFERRED TO OUTPUT COUPLER
- WHEN "OFF" POWER IS DISSIPATED INTO TERMINATION OF THE FIRST COUPLER AND NO POWER IS TRANSFERRED TO OUTPUT COUPLER

VII-2-309



STANFORD  
TELECOMMUNICATIONS INC.

## ALTERNATE SWITCHING DEVICES

Before implementing the switch, two design choices are to be made. One is the identification of the architecture to be used, while the other is to choose an appropriate switching device. A comparison is presented of four (4) candidate switching devices on the basis of the following key parameters:

- Speed
- Insertion gain
- Device isolation
- DC power requirements
- Size/weight.

The Dual Gate GaAs MESFET is identified as the preferred choice.

## ALTERNATE SWITCHING DEVICES

SWITCHING TECHNOLOGY	SPEED	INSERTION GAIN	DEVICE ISOLATION	DC POWER REQUIREMENTS	RELATIVE SIZE, WEIGHT
FERRITE	0.1-1 ns	-0.25 dB	15 dB	HIGH CURRENT (1A)	LARGE, HEAVY
PIN DIODE	10-100 ns	-0.25 dB	20 dB	LOW VOLTAGE LOW CURRENT (10 ma)	SMALL, LIGHT
GaAs MESFET	0.1-1 ns	-3 dB	10-15 dB	LOW VOLTAGE (3V)  LOW CURRENT (10 ma)	SMALL, LIGHT
DUAL GATE* GaAs MESFET	0.1-1 ns	+15 dB	25-30 dB	LOW VOLTAGE (3V)  LOW CURRENT (30 ma)	SMALL, LIGHT

\* PREFERRED CHOICE.

REF: LOC CIT NASA/LEWIS RESERACH CENTER



**STANFORD  
TELECOMMUNICATIONS INC.**

### ONE-WAY CROSSPOINT DESIGN

The chart shows a simplified functional block diagram of a possible crosspoint switch suitable for use when a one-way (input-to-output) operational capability is required. It suffices to show the design at only one crosspoint of an NxM switch. At the crosspoint, both the input and output bars contain a directional coupler. The signal from the input bar can be coupled to the output bar only when the two (2) AMP/SWITCH units are closed. If the AMP/SWITCH units are not closed, no signal is coupled from the input to the output; thus, the routing path which required this particular crosspoint to be closed can not be established.

ONE-WAY CROSS POINT DESIGN

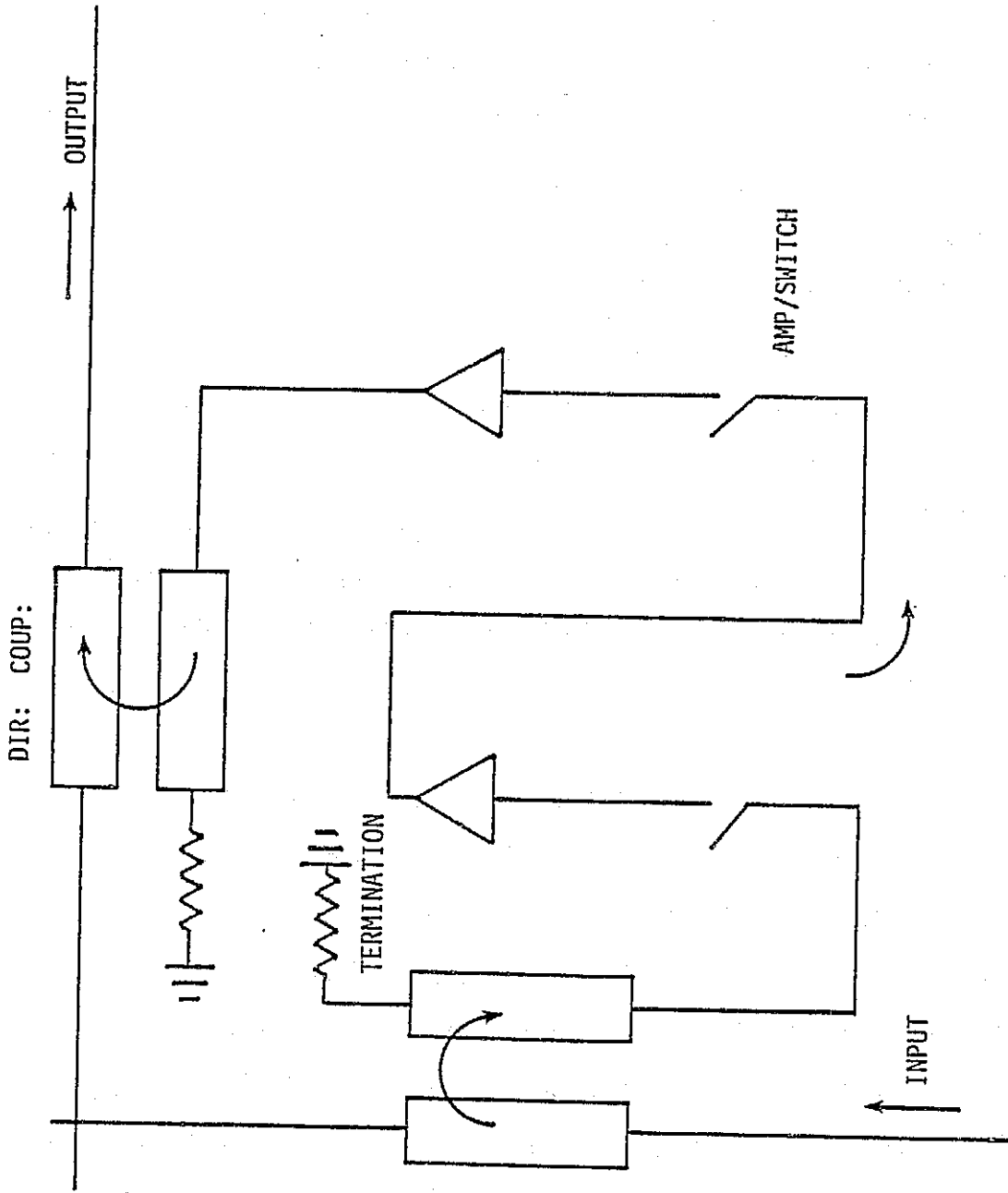

C-4

## TWO-WAY CROSSPOINT DESIGN

The crosspoint design of a switch with a two-way (input  $\rightleftarrows$  output) operational capability is different from that of a one-way (input  $\rightarrow$  output) switch. The figure shows the functional block diagram of a possible crosspoint switch suitable for use with a two-way operational capability.

From an architectural viewpoint, the design is the same as the one-way crosspoint design depicted in the previous chart. However, to provide a two-way operational capability, there are two directional couplers in the input and output bar at each crosspoint. (It suffices to show the design at only one crosspoint of an NxM switch.) Also, there are two sets of AMP/SWITCH units. This provides a set of directional coupler plus AMP/SWITCH units for each direction of transmission. Solid arrows on the directional couplers show the directionality of signal coupling between the directional coupler and the AMP-SWITCH for the input-output direction of operation. The dotted arrows depict the same for the reverse direction of operation.

TWO WAY CROSS POINT DESIGN

ORIGINAL PAGE 19  
OF POOR QUALITY

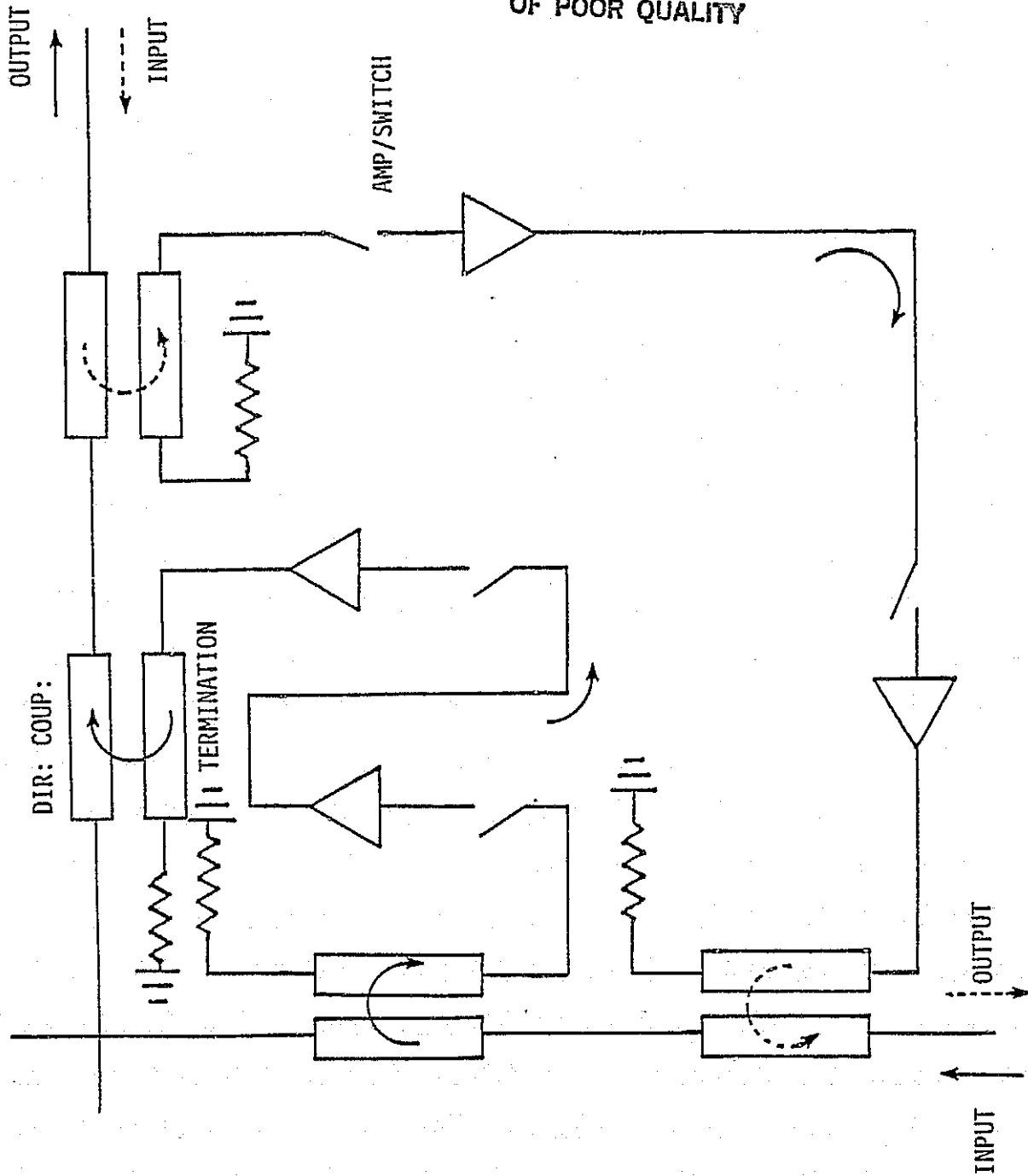

STANFORD  
TELECOMMUNICATIONS INC.



SUMMARY/CONCLUSIONS

In assessing the switch technology to satisfy the TDAS requirements, the listed summary/conclusions were obtained.



SUMMARY/CONCLUSIONS

- COUPLER CROSS-BAR ARCHITECTURE IS MOST SUITABLE FOR BOTH 1-WAY/2-WAY SWITCH
- 2-WAY SWITCH APPEARS FEASIBLE
- DUAL GATE GaAs MESFET SWITCHING ELEMENTS ARE MOST SUITABLE
- COMPACT MMIC DESIGN POSSIBLE

VII-2-317



STANFORD  
TELECOMMUNICATIONS INC.

## COUPLER CROSSBAR SWITCH MATRIX TECHNOLOGY

Technology issues which resulted from the technology assessment effort are listed in the next two charts, along with the R&D efforts needed to resolve these issues. The identification of technology issues and the R&D efforts needed to resolve them for the switch subsystem assembly is broken down on the basis of the following components:

- Switch:

- Directional couplers
- Input couplers
- Output couplers
- Switching device
- Crosspoint design

- Distribution Control Unit:

- Switch control decoder
- Frequency synthesizer control unit
- Frequency converters.

COUPLER CROSSBAR SWITCH MATRIX TECHNOLOGY (CONTINUED)

The technology issue arising out of directional couplers (which include input couplers and output couplers) is the difficulty of maintaining constant power levels at the switch crosspoints to achieve constant power levels at the switch output. Coupling coefficient inaccuracies prevent achieving constant power levels. Current technology permits approximately 0.1 dB coupling errors which yield unacceptable power level variations. The R&D efforts needed to resolve this problem is to improve coupler fabrication techniques with the objective of enhancing coupling coefficient accuracy.

The only technology issue regarding the preferred switching device (Dual Gate GaAs MESFET) is its vulnerability to space radiation effects which alter its operating characteristics. The R&D effort needed to resolve the issue is the determination of required shielding thickness so that the space radiation reaching the electronic components is at a low enough level to not affect their performance.

PRECEDING PAGE BLANK NOT FILMED

COUPLER-CROSSBAR SWITCH MATRIX  
TECHNOLOGY

ASSEMBLY

KEY COMPONENTS AND USE

CRITICAL TECHNOLOGY ISSUES

R&D NEEDED

SWITCH:

MICROSTRIP DIRECTIONAL COUPLERS:

INPUT COUPLERS: USED TO DIRECT INPUT IF SIGNAL FROM THE INPUT TRANSMISSION LINE TO THE SWITCH INPUT

OUTPUT COUPLERS: USED TO DIRECT SWITCHED IF SIGNAL FROM THE SWITCH OUTPUT TO THE OUTPUT TRANSMISSION LINE

DUAL GATE GaAs MESFET: USED AS THE SWITCHING DEVICE

DUE TO COUPLING, COEFFICIENT INACCURACIES OF  $\pm 0.1$  DB AVAILABLE WITH CURRENT TECHNOLOGY CONSTANT POWER LEVELS AT SWITCH CROSSPOINT CAN NOT BE MAINTAINED

SPACE RADIATION CAN CHANGE THE OPERATING CHARACTERISTICS OF THE FET

IMPROVE FABRICATION OF COUPLERS SO THAT COUPLING COEFFICIENT IS AS INVARIANT AS POSSIBLE OVER THE REQUIRED BANDWIDTH

DEVELOPMENT OF PROPER SHIELDING TO MINIMIZE THE RADIATION EFFECT

VII-2-321



STANFORD  
TELECOMMUNICATIONS INC.

## COUPLER CROSSBAR SWITCH MATRIX TECHNOLOGY (CONTINUED)

If a Switch with a two-way operational capability is to be provided on the TDAS S/C, it is equivalent to providing two (2) one-way Switches. The consequent doubling of Size and weight emerges as the technology issue, and the needed R&D effort is the development of a miniaturized two-way Switch using MMIC (monolithic miniaturized integrated circuit) technology.

The Distribution Control Unit (DCU), key components of which were previously enumerated, is an important element of the Switch. The DCU provides intelligence and control functions for operating the Switch. For the Switch Control decoder component, because of the simplicity of its design, no problems are foreseen. Therefore, there are no technology issues, and no R&D effort is needed. The frequency Synthesizer Control Unit is intended to assign intermediate frequencies for providing Switch connectivity according to an appropriate algorithm. This algorithm should provide conflict-free frequency assignments. This requirement is the main technology issue, the resolution of which requires development of an optimal algorithm.

COUPLER-CROSSBAR SWITCH MATRIX  
TECHNOLOGY (CONT'D)

<u>ASSEMBLY</u>	<u>KEY COMPONENTS AND USE</u>	<u>CRITICAL TECHNOLOGY ISSUES</u>	<u>R&amp;D NEEDED</u>
DISTRIBUTION CONTROL UNIT (DCU)	<u>2-WAY CROSS POINT:</u> SWITCHING DEVICE USED TO PROVIDE 2-WAY OPERATION	SWITCH MATRIX SIZE DOUBLES	DEVELOPMENT OF MINIATURIZED 2-WAY SWITCH USING MMIC TECHNOLOGY TO REDUCE SIZE
	<u>SWITCH CONTROL DECODER:</u> CONVERTS CONTROL BLOCKS TO DC SWITCH CONTROL VOLTAGE AT EACH CROSSPOINT	NON-STRINGENT TIMING REQUIREMENTS MAKE DECODER DESIGN STRAIGHT-FORWARD. NO PROBLEMS FORESEEN.	
	<u>FREQUENCY SYNTHESIZER CONTROL UNIT:</u> CONTROLS THE IF FREQUENCIES OF THE INPUT SIGNALS	THIS COMPONENT MUST HAVE A FREQUENCY ASSIGNMENT ALGORITHM WHICH MAY BE EXECUTED ON BOARD OR ON GROUND AND SHOULD BE BANDWIDTH EFFICIENT AND CONFLICT-FREE	DEVELOPMENT OF AN OPTIMAL ALGORITHM
	<u>FREQUENCY CONVERTERS:</u> USED FOR CONVERSION OF RF SIGNALS TO IF BEFORE SWITCHING. CONTROLLED BY THE FREQUENCY SYNTHESIZER CONTROL UNIT.	SPURIOUS SIGNALS PRODUCED MUST BE MINIMAL. BECAUSE THERE MAY BE UP TO N CONVERSIONS, THE SIZE OF THE CONVERTERS SHOULD BE MINIMUM.	DEVELOPMENT OF SMALL, FREQUENCY CONVERTERS COMPATIBLE WITH THE SWITCH MATRIX IF RANGE.

VII-2-323



STANFORD TELECOMMUNICATIONS INC.

COUPLER CROSSBAR SWITCH MATRIX TECHNOLOGY (CONTINUED)

Regarding the frequency converters, two technology issues emerge when the Switch is to be implemented. These are the production of Spurious Signals and the Size and weight of frequency converters which become more critical as the Switch dimensions increase. The R&D effort needed to settle these issues consists of the development of small frequency converters with low spurious outputs.

ADDITIONAL SWITCH UNIQUE R&D NEEDED

On the basis of the R&D needs identified to resolve the technology issues and other developments in the Switch and related areas now taking place, the additional Switch unique R&D efforts needed are listed.

PRECEDING PAGE BLANK NOT FILMED

VII-2-326



ADDITIONAL SWITCH UNIQUE R&D NEEDED

• DEVELOPMENT OF

- CROSS-BAR ARCHITECTURE SWITCH
- BROADBAND SWITCHING ELEMENTS (>2.5 GHZ BW)
- DIRECTIONAL COUPLERS WITH PRECISE COUPLING COEFFICIENTS OVER THE ENTIRE BAND
- SWITCH INTELLIGENCE AND CONTROL UNIT
- SPACE RADIATION PROTECTIVE SHIELD



STANFORD  
TELECOMMUNICATIONS INC.

2.2.5

MBA TECHNOLOGY

The elements addressed in this section of the report are listed.

## MBA TECHNOLOGY

- MBA REQUIREMENTS FOR TDAS
- FUNCTIONAL BLOCK DIAGRAM
- DESIGN ALTERNATIVES
- SUMMARY/CONCLUSIONS
- TECHNOLOGY OF KEY COMPONENTS
  - CRITICAL TECHNOLOGY ISSUES
  - R&D NEEDED
- ADDITIONAL MBA UNIQUE R&D NEEDED

VII-2-329



STANFORD  
TELECOMMUNICATIONS INC.

## MBA REQUIREMENTS

The requirements of the multiple beam antenna (MBA) to be provided on the TDAS S/C to interface with ground locations are listed. Out of four (4) Scannable feeds, three (3) will be operational while the fourth will be a backup.

## MBA REQUIREMENTS

FREQUENCY	30/20 GHZ
GAIN	> 45 DB @ 20 GHZ
POLARIZATION	DUAL
COVERAGE	CONUS LOCATIONS
FEEDS	5 - FIXED FEEDS 4 - SCANNABLE FEEDS

VII-2-331



STANFORD  
TELECOMMUNICATIONS INC.

## MBA MODULE

The functional block diagram of the MBA module and the Subsystem that it interfaces with are shown. The figure depicts a module for receiving four (4) inputs and Switching them to four (4) MBA feeds. However, in its actual implementation the module design will incorporate a N X M Switch, where the number of inputs (n) may be as many as 30 and the number of outputs (M) may be as many as nine (9). The Switch works at intermediate frequencies (IF) under the control of the Switch Control and Intelligence Subsystem. The frequencies of the incoming signals are converted to IF before the signals are routed through the switch. At the output of the switch, the signals at IF frequencies are appropriately up converted for downlink transmission through the Multiple Beam Antenna (MBA).

# MBA MODULE

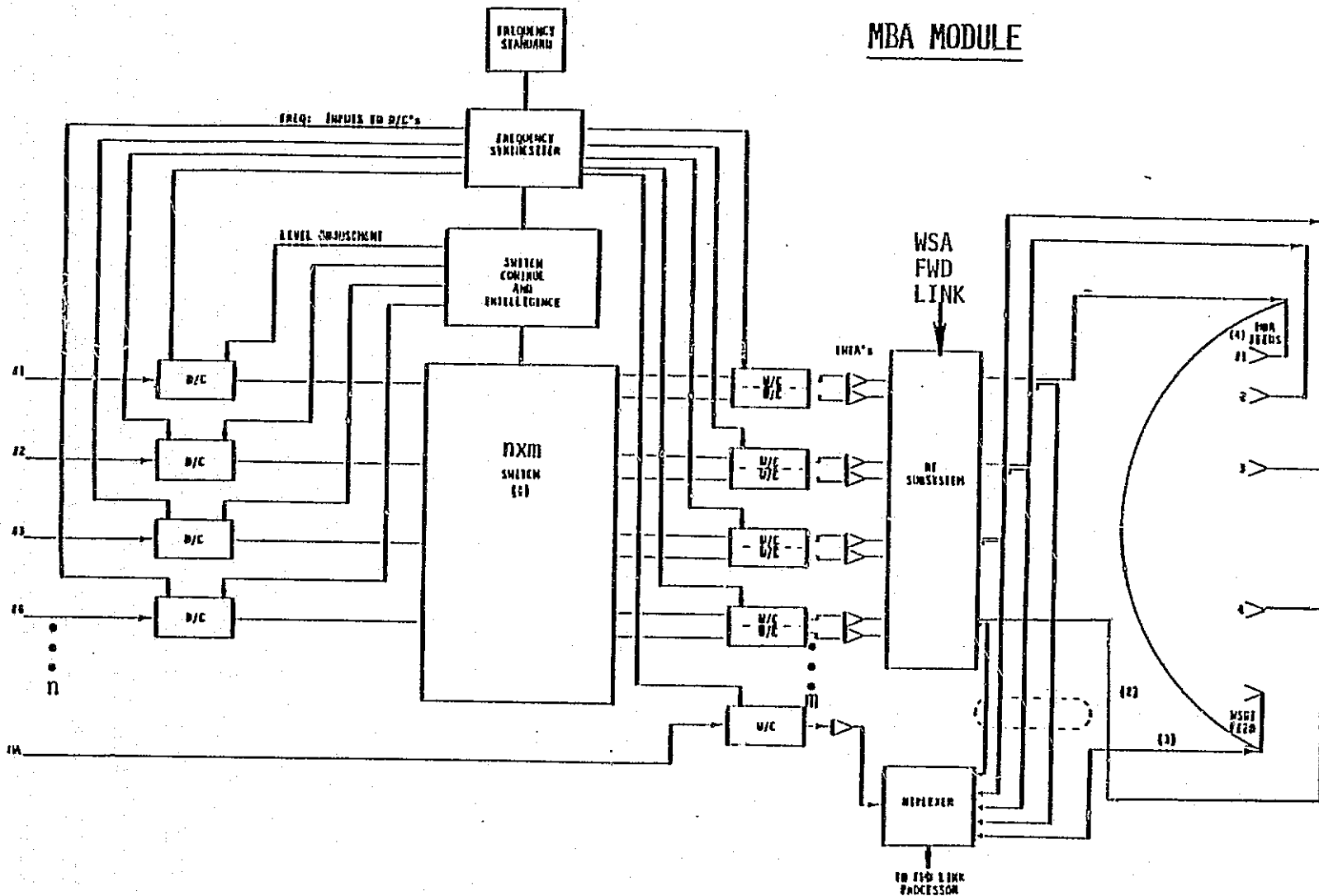

- NOTES: (1) THE SWITCH IS NOT RESTRICTED TO 4x4 (nxm SWITCH CAN BE IMPLEMENTED; n>4, m => 5).  
 (2) PROVIDES WSGT KNOWLEDGE THAT VARIOUS CONUS LOCATIONS ARE RECEIVING DATA.  
 (3) ABILITY TO SWITCH WSGT TO OTHER FEED IN CASE OF FAILURE IS NOT SHOWN.  
 (4) MOVEABLE FEEDS NOT SHOWN.

VII-2-333

ORIGINAL PAGE IS  
OF POOR QUALITY



## DESIGN ALTERNATIVES

In order to transfer data from the TDAS to the ground locations, several alternatives exist for the MBA design. The areas in which these alternatives exist are listed as:

- The type of multiple beam antenna
- A single reflector antenna or an antenna consisting of a main reflector and a subreflector
- The antenna feeds.



DESIGN ALTERNATIVES

- NUMBER OF MBA'S PER TDAS
- ANTENNA TYPES
- SINGLE/DUAL REFLECTOR (MAIN REF. + SUB REF.) MBA
- FEEDS
  - APERATURE SHAPE
  - SINGLE FEED/FEED CLUSTERS.

NUMBER OF MBA'S PER TDAS

The table summarizes the impact of using one or two MBA's per TDAS Satellite, and alternative feed allocations in these two cases, on the total number of feeds on each antenna on electrical performance, and on spacecraft integration.

## NUMBER OF MBA'S PER TDAS

NO. OF SEPARATE TDAS	ANTENNA 1	TOTAL NO. OF FEEDS	ANTENNA 2	TOTAL NO. OF FEEDS	ELECTRICAL PERFORMANCE	SPACECRAFT INTEGRATION
1) one	5 FF for T and R at 25 GHz freq. 4 MF for T and R at 25 GHz freq.	9	NA	NA	Performance is compromised. More complex design and implementation.	Lighter. Lower stowage volume.
2) one	5 FF for T at 20 GHz. 5 FF for R at 30 GHz. 4 MF for T at 20 GHz. 4 MF for R at 30 GHz	18	NA	NA		
3) two	5 FF for T at 20 GHz. 4 MF for T at 20 GHz	9	5 FF for R at 30 GHz. 4 MF for R at 30 GHz	9	Good EE Performance. Easier to implement.	Heavy. High stowage volume.
4) two	5 FF for T at 20 GHz. 5 FF for R at 30 GHz	10	4 MF for T at 20 GHz. 4 MF for R at 30 GHz	8		

FF = FIXED FEED  
T = TRANSMIT  
R = RECEIVE  
MF = MOVABLE FEED

ORIGINAL PAGE IS  
OF POOR QUALITY

VII-2-337



**STANFORD  
TELECOMMUNICATIONS INC.**

## ANTENNA TYPES

The suitability of the various antenna types investigated for use as the MBA for the TDAS Satellite is summarized. Advantages and Disadvantages of each antenna type are identified.

## ANTENNA TYPES

<u>TYPE</u>	<u>ADVANTAGES/DISADVANTAGES (+)</u>
PHASED ARRAY	<ul style="list-style-type: none"><li>+ ● MULTIPLE BEAM FORMING NETWORKS REQUIRED FOR 30 AND 20 GHZ</li><li>+ ● BEAM FORMING NETWORK IS COMPLICATED</li><li>+ ● DIFFICULT TO OBTAIN MULTIPLE INDEPENDENT SCANNABLE BEAMS</li><li>+ ● GRATING LOBES APPEAR</li><li>+ ● TO AVOID GRATING LOBES LARGE NUMBER OF ELEMENTS ARE NEEDED.</li></ul>
LENS	<ul style="list-style-type: none"><li>● HEAVY (DEPENDENT UPON MATERIAL USED AND GAIN REQUIREMENT)</li><li>● W/G LENS<ul style="list-style-type: none"><li>- BW CAPABILITY IS &lt; 3%</li><li>- DESIRED MANUFACTURING TOLERANCES ARE DIFFICULT TO HOLD</li></ul></li><li>● DIELECTRIC LENS<ul style="list-style-type: none"><li>- UNSUITABLE FOR WIDE SCAN ANGLES.</li></ul></li></ul>
REFLECTOR	<ul style="list-style-type: none"><li>● LIGHT</li><li>● GOOD EFFICIENCY</li><li>● NO GRATING LOBE PROBLEMS</li><li>● ALTERNATIVE CONFIGURATIONS POSSIBLE</li><li>● ALTERNATIVE FEED/SCANNING TECHNIQUES POSSIBLE.</li></ul>

VII-2-339



STANFORD  
TELECOMMUNICATIONS INC.

SINGLE/DUAL REFLECTOR MBA

Bath the dual and single reflector MBAs appear promising.

## SINGLE/DUAL REFLECTOR MBA

### TYPE

DUAL REFLECTOR  
(MAIN REF. + SUB REF.)

### ADVANTAGES/DISADVANTAGES (+)

- HIGH EFFICIENCY
- LOW SIDELobe LEVELS
- LOW GAIN DEGRADATION DUE TO SCANNING
- + ● HIGH COST
- + ● HIGH COMPLEXITY
- + ● DIFFICULT TO HOLD ALIGNMENT OF DUAL REFLECTORS
- + ● DESIRED MANUFACTURING TOLERANCES ARE DIFFICULT TO HOLD.

SINGLE REFLECTOR  
(NO SUB REF., FRONT  
FED MAIN REF.)

- + ● LOW EFFICIENCY
- + ● HIGH SIDELobe LEVELS
- + ● HIGH GAIN DEGRADATION DUE TO SCANNING
- LOW COST
- LOW COMPLEXITY
- ACCURATE ALIGNMENT POSSIBLE
- DESIRED MANUFACTURING TOLERANCES ACHIEVABLE.

VII-2-341



STANFORD  
TELECOMMUNICATIONS INC.

## FEEDS

The feed subsystem is an important component of the Multiple Beam Antenna (MBA) System and governs its performance. Feed elements are used to synthesize feed subsystems which illuminate the main reflector and subreflector. A single feed element may be circular or square in cross section. The feed subsystem may be a cluster of feed elements having a triangular or square grid configuration as shown in the chart. Also identified are the promising candidate feed element and feed cluster and the characteristics of each.



## FEEDS

<u>TYPE</u>	<u>CANDIDATE</u>	<u>REASON</u>
<u>SINGLE FEED</u> CIRCULAR VS. SQUARE FEED	SQUARE $1.5\lambda \times 1.5\lambda$	<ul style="list-style-type: none"> <li>• SQUARE FEED HAS LESS CROSS POLARIZATION</li> <li>• SQUARE FEED HAS BETTER POLARIZATION ALIGNMENT</li> <li>• SQUARE FEED PROVIDES HIGHER EFFICIENCY.</li> </ul>
<u>FEED CLUSTER</u> SQUARE GRID* VS. TRIANGULAR( $\Delta$ ) GRID	TRIANGULAR GRID	<ul style="list-style-type: none"> <li>• <math>\Delta</math> GRID HAS SMALLER CLUSTER, LESS OVERLAP LOSS</li> <li>• <math>\Delta</math> GRID HAS SMALLER NUMBER OF ELEMENTS IN CLUSTER WHICH MAKES A SIMPLER BFN.</li> </ul>

\* FEED CLUSTER CONFIGURATION

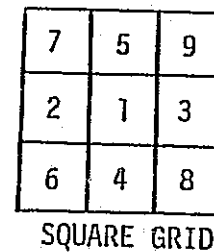
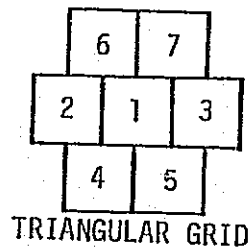

NOTE: FOR SOME PERFORMANCE TRIANGULAR GRID REQUIRES LESS ELEMENTS (AS AN EXAMPLE, RATIO OF NUMBER OF ELEMENTS IS  $\approx 7:9$ ).



STANFORD  
TELECOMMUNICATIONS INC.

## SCANNABLE FEED APPROACH/BACK-UP CAPABILITY

The chart documents the results of investigations conducted to identify candidate approaches for scanning movable feeds and means by which feed back-up capability can be provided. In order to make the MBA flexible in transferring data to chosen locations in CONUS, in addition to fixed beams provided by fixed feeds, a total of four (4) Scannable feeds can be reasonably provided. Out of these four, three could be operational and would be a back-up. Mechanical Scanning is a preferable approach, and back-up capability can be provided by a design that provides overlapping coverage for movable feeds. (In addition, movable feeds may be designed to have a large scan angle capability to provide back-up for covering a larger area at the expense of reduced gain).

## SCANNABLE FEED APPROACH/BACK UP CAPABILITY

- MECHANICALLY SCANNABLE FEED\*  
ONE MECHANICALLY MOVABLE FEED FOR EACH  
OF FOUR SCAN REGIONS OF CONUS

- NE
- NW
- SE
- SW

THE STEER ANGLE FOR EACH FEED

- 2 DEG E-W
- 1 DEG N-S

PER SCAN REGION

- ELECTRONICALLY SCANNABLE FEEDS
- BACK UP CAPABILITY
  - DESIGN THAT PROVIDES OVERLAPPING  
COVERAGE FROM 4 MOVABLE FEEDS
  - DESIGN ALL 9 FEEDS TO BE MOVABLE

\* PREFERRED CHOICE BECAUSE OF LESS BLOCKAGE.



## FIXED FEED LOCATIONS

The chart lists the results of the efforts conducted to establish the feasibility of implementing one promising candidate MBA configuration (Front-Fed Single Reflector — No Subreflector) with five (5) fixed feeds corresponding to five (5) fixed CONUS locations. The assumptions under which this investigation was carried out are listed. Other items listed in the table include the five fixed locations, their longitudes and latitudes, the angle between the antenna boresight and the antenna beams' RF axis directed at their respective ground locations, and for each ground station the feed location for the corresponding beam. The feed locations are expressed both in terms of their angular deviation from the mechanical boresight and in terms of the distance measured in the aperture plane (which is orthogonal to the mechanical boresight axis) from the projection of the focal point in this plane.

FIXED FEED LOCATIONS  
(FRONT FED SINGLE REF - NO SUB REF CONFIG)\*

GROUND STATION	LATITUDE	LONGITUDE	ANGLE BETWEEN BORESIGHT AND THE STATION	FEED LOCATION	
				OFF ANGLE	DISTANCE FROM FOCAL POINT
GSFC MD	39°N	77°W	2.58°	2.32°	5.47 cm
HOUSTON TX	29°N	95°W	1.36°	1.23°	2.90 cm
WS NM	32°N	106°W	1.6°	1.44°	3.39 cm
SUNNYVALE CA	37.5°N	122°W	3.26°	2.93°	6.91 cm
COLORADO SPRINGS CO	39°N	106°W	1.19°	1.07°	2.52 cm

ORIGINAL PAGE IS  
OF POOR QUALITY

ASSUMPTIONS:

- THE MECHANICAL BORESIGHT OF THE ANTENNA IS POINTING TO (LATITUDE = 39°N, LONGITUDE = 97°W)
- ANTENNA F/D = 0.45
- FREQUENCY = 25 GHZ
- BEAM DEVIATION FACTOR = 0.9
- ANTENNA APERTURE DIAMETER = 3 METERS
- SATELLITE LOCATION 97° WEST LONGITUDE (ANT. PERFORMANCE PRACTICALLY INSENSITIVE TO SAT. LOC. CHANGE OF ± 20 DEG)

\* THIS IS AT LEAST ONE TECHNIQUE FOR WHICH RISK IS LOW.



STANFORD  
TELECOMMUNICATIONS INC.

## PROJECTION OF GROUND STATIONS AND FIXED FEED LOCATIONS

The figure depicts the locations of five (5) fixed feeds and proportionately the five fixed ground locations to which they respectively correspond. The feed and ground locations are shown projected on the aperture plane which is orthogonal to the mechanical boresight axis. The circle drawn is intended to indicate (not to scale nor with respect to proportionality as used to show feed and ground locations) the main reflector contour.

# PROJECTION OF GROUND STATIONS AND FIXED FEED LOCATIONS

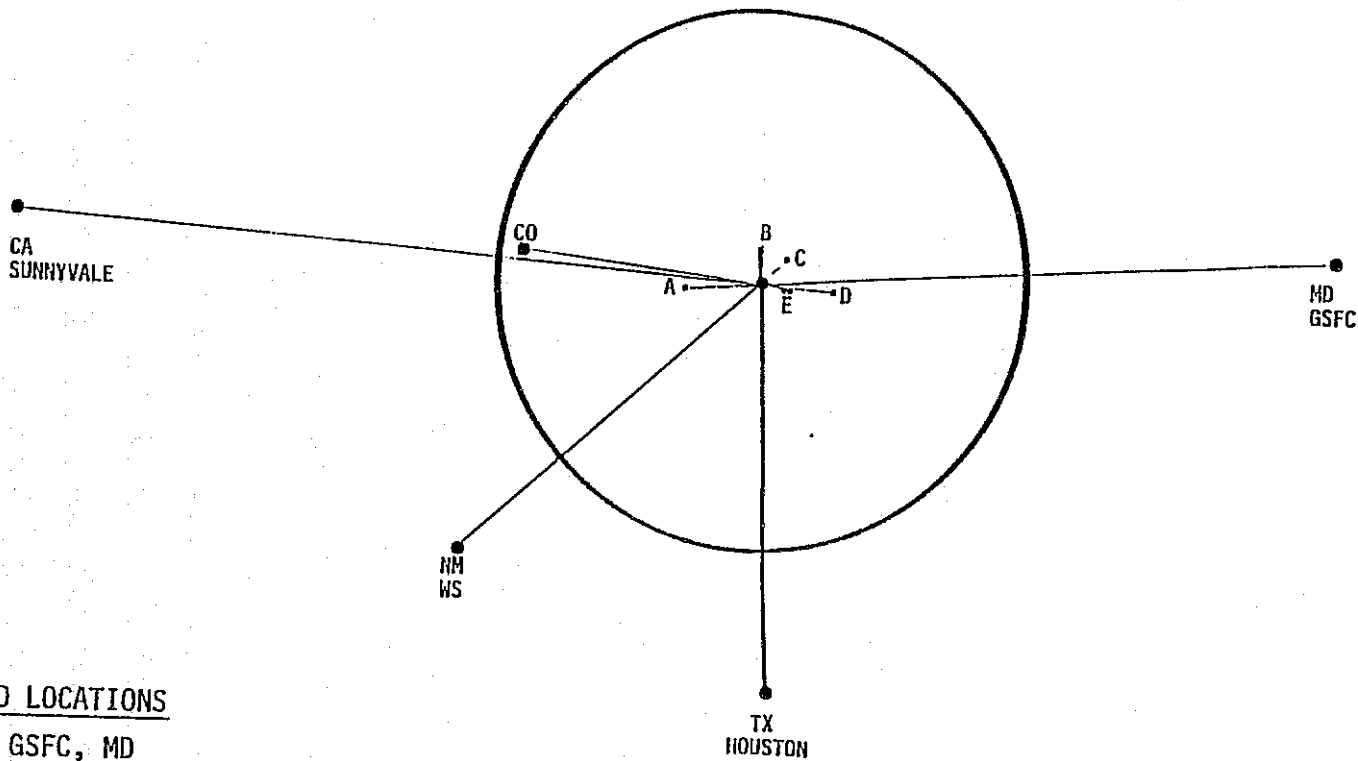

## FEED LOCATIONS

- A = GSFC, MD
- B = HOUSTON, TX
- C = WS, NM
- D = SUNNYVALE, CA
- E = COLORADO SPRINGS, CO

ORIGINAL PAGE IS  
OF POOR QUALITY



STANFORD  
TELECOMMUNICATIONS INC.

SUMMARY/CONCLUSION

The A summary of the results of MBA technology assessment effort and the conclusions drawn therefrom are presented.



## SUMMARY/CONCLUSIONS

- SINGLE MBA FOR TX/RX DESIRABLE
- REFLECTOR ANTENNA IS OPTIMUM CHOICE
- MULTIPLE REFLECTOR (MAIN REF + SUB REF) ANTENNA WILL REQUIRE CAREFUL FABRICATION TO PROVIDE DIMENSIONALLY STABLE RIGID STRUCTURE
- SINGLE REFLECTOR (NO SUB REF) FRONT FED CONFIGURATION SHOULD BE THE FIRST CHOICE IF IT CAN SATISFY REQUIREMENTS
- SQUARE FEED ELEMENTS IS OPTIMUM CHOICE
- NINE FEED DESIGN APPEARS DOABLE
- MECHANICALLY SCANNABLE FEED PREFERRED



STANFORD  
TELECOMMUNICATIONS INC.

## MBA TECHNOLOGY

Technology issues which resulted from the technology assessment effort are listed, along with the R&D efforts needed to resolve these issues. Identification of technology issues and the associated R&D efforts needed is broken down on the basis of the following components of the MBA Subsystem:

- Reflector/Subreflector
- Feed Subsystem
- Support Structures

The technology issues related to the Reflector/Subreflector of the MBA are related to the MBA gain and the weight burden in places on the TDAS S/C. The Reflector/Subreflector Surface roughness, which is especially critical at 30/20 GHz band, and the ohmic losses on their surfaces degrade MBA gain. Degradation in gain also takes place due to misalignment between the relative parts of Antenna Subsystem. The goal of the needed R&D effort should be to achieve Reflector/Subreflector surface roughness of approximately 1/32 cm, and their material selection should provide high rigidity, low ohmic losses and light weight.

## MBA TECHNOLOGY

### ASSEMBLY

### KEY COMPONENTS & USE

MBA

REFLECTOR/SUBREFLECTOR  
COLLIMATE FEED OUTPUT  
INTO FINAL BEAMS.

FEED S/S  
PROVIDE NECESSARY  
APERTURE ILLUMINATION  
TO YIELD REQUIRED ANT:  
BEAMS & RADIATION  
PATTERNS

SUPPORT STRUCTURES  
MAINTAIN REF, SUBREF &  
FEEDS AT THEIR PRECISE  
LOCATIONS

### CRITICAL TECHNOLOGY ISSUES

- MBA GAIN DEGRADES DUE TO:
  - SURFACE ROUGHNESS (REQMTS INCREASE WITH FREQ; CRITICAL AT 30/20 GHZ)
  - I<sup>2</sup>R LOSSES IN REF/SUBREF SURFACE
  - DEVIATION FROM REQD ALIGNMENT BETWEEN RELATIVE PARTS OF ANTENNA STRUCTURE.
- MBA PLACES WEIGHT BURDEN ON TDAS S/C
- APERTURE ILLUMINATION & GAIN DEGRADES DUE TO
  - FEED SURFACE LOSS
  - SHAPE DISTORTION
  - APERTURE BLOCKED BY FEED
- LIFE OF MECHANICALLY SCANNABLE FEEDS IS LIMITED
- PLACE WEIGHT BURDEN ON TDAS
- DUAL FREQ/DUAL POL FEED TECH AT 30/20 GHZ HAS NOT ATTAINED MATURITY
- SUPPORT STRUCTURES IN FRONT OF REFLECTOR APERTURE DEGRADE APERTURE ILLUMINATION & GAIN DUE TO EM SCATTERING & BLOCKAGE
- STRUCTURAL FLEXIBILITY CAUSES MISALIGNMENT & CONSEQUENTLY DEGRADES PERFORMANCE

### R&D NEEDED

- DEVELOPMENT OF REF/SUBREF HAVING:
  - 1/32 CM RMS SURFACE SMOOTHNESS
  - HIGH RIGIDITY TO MAINTAIN ALIGNMENT
  - LOW LOSS AT 30/20 GHZ
  - LIGHT WEIGHT
- LOW LOSS/LIGHT WT FEEDS (CANDIDATE TECH: GOLD PLATED GFRP)
- MECHANICALLY SCANNABLE FEEDS WHICH
  - CAUSE LOSS BLOCKAGE
  - SATISFY TDAS LIFE REQMS
- ENHANCE 30/20 GHZ FEED DEVELOPMENT TECHNOLOGY
- MECH: DISTORTION FREE FEED STRUCTURE
- IDENTIFICATION OF ADEQUATE CONFIGURATION & SURFACE PROPERTIES OF SUPPORT STRUCTURE & MATERIAL WHICH CAUSE REDUCED BLOCKAGE & SCATTERING AT 30/20 GHZ

VII-2-353



STANFORD  
TELECOMMUNICATIONS INC.

### MBA TECHNOLOGY (CONTINUED)

The technology issues related to the feed subsystem are the MBA gain degradation, the limited life of mechanically scannable feeds, the weight burden it places on the TDAS S/C and the immaturity of dual frequency/dual polarization feed technology. The R&D effort needed to resolve the issues is enumerated.

The support structures, although not functional, nevertheless form an important part of the antenna subsystem. The technology issue related to the structures is the degradation of the MBA gain due to electromagnetic scattering and blockage due to structural elements and misalignment of the antenna system. Resolution of these issues requires adequate materials, configurations and surface properties of the support structures.

ADDITIONAL MBA UNIQUE R&D NEEDED

Based upon the multiple beam antenna experience built up in the past in the NASA and industrial sectors and the other ongoing development activities, the additional MBA unique R&D effort needed is listed.

PRECEDING PAGE BLANK NOT FILMED

## ADDITIONAL MBA UNIQUE R&D NEEDED

- DEVELOPMENT OF
  - LIGHT WT/RIGID REFLECTOR WITH  $\geq 1/32$  CM RMS SURFACE SMOOTHNESS
  - LOW LOSS/LIGHT WT (GOLD PLATED GRAPHITE FIBER REINFORCED PLASTIC) FEEDS AND WAVEGUIDES
  - MECHANICALLY SCANNABLE LONG LIFE FEEDS
  - DUAL FREQ/DUAL POL FEEDS

VII-2-357



STANFORD  
TELECOMMUNICATIONS INC.

What appears to be the feasible range of architectures for the TDAS crosslink has been presented in Volume IV of this report. Some ranking of alternatives has been performed with respect to issues other than the technological details of the crosslink mechanism itself. With all that systems engineering accomplished, we can turn to the subject of evaluating the competing crosslink technologies for TDAS. One subsection is devoted to each of the four under consideration, which are: 60 GHz RF, Nd:YAG laser, CO<sub>2</sub> laser, and GaAs laser. The crossreferencing between these and the architecture alternatives is summarized in Figure 2-1.

Because the crosslink configurations under discussion are fixed, it will be easy to relate the technology features to the areas of architecture in which they have most impact. Rational assessment of technology for this application is made much easier by the prior formulation of the four alternatives A-D, listed below.

- A: RF Transponder
- B: Laser Demod/Remod
- C: Laser Transponder, Direct Detection
- D: Laser Transponder, Meterodyne Detection.

VII-2-369

TECHNOLOGY	ALTERNATIVES			
	A	B	C	D
60 GHz RF	✓	✓		
Nd:YAG Laser		✓		
CO <sub>2</sub> Laser			✓	
GaAs Laser			✓	✓

ORIGINAL PAGE IS  
OF POOR QUALITY

FIGURE 2-1: Pairings of crosslink alternatives and applicable technologies. The combinations checked in the above table are the ones that are under study in this section. As each technology exposition is given, it will be related back to the crosslink configurations to which it pertains.



## 60 GHZ RF TECHNOLOGY

The 60 GHz technology will be the simplest of the four, primarily because there is only one salient issue: generation of sufficient EIRP and the partition of that EIRP between RF power and antenna gain. It is pertinent to note that in prior consideration of the WSA user service, which accommodates up to 50 Mbps, 10 W into a 1 m gimbaled parabolic antenna (EIRP = 63 dBW) with a 450°K receiver was found to be adequate. Several R&D recommendations attended this baseline position, however. Research in reflector surface smoothness, autotracking components, power combining of IMPATT amplifiers, and low noise figure receivers was called for. The demands of a 60 GHz crosslink will accentuate these needs.

An illustrative link budget for the crosslink is shown in Figure 2-2. In this budget, and those to follow, the required crosslink capacity is taken to be 1.8 Gbps. The TDAS spacecraft are located at 100°W and 62°E in synchronous orbit. By taking both crosslink dishes to be 4 m with 20 W output, the 1.8 Gbps link closes with 5 dB margin.

There is a trade between gain and power. To obtain 20 W RF at 60 GHz requires coherent power combination of ten to twenty impatts. This burden cannot be appreciably eased by providing more gain. Aperture exceeding 2 m is difficult to accommodate on the TDRS bus because of blockage and moment-arm considerations. Therefore, the illustrative link budget seems to represent a reasonable operating point requirement for the 60 GHz crosslink.

Conventional cable and waveguide structures are quite lossy at 60 GHz. To minimize losses between the HPA and antenna, a beam waveguide may be used. This represents one of the many technical challenges that await an RF crosslink implementation.

## FIGURE 2-2: 60 GHZ CROSSLINK BUDGET

Transmitter Power (20 W)	13.0 dBW
Transmit Gain (4 m)	65.0 dB
Path Loss (162° separation, synchronous)	-226.3 dB
Receive Gain (4 m)	65.0 dB
Received Power (C)	-83.3 dBW
Receiver Temperature (1000°K)	30.0 dB°K
Boltzman's Constant	-228.6 dBJ/°K
Noise Power Density ( $N_0$ )	-198.6 W/Hz
$C/N_0$	115.3 dBHz
Data Rate (1.8 Gbps)	92.5 dBHz
$E_b/N_0$ available	22.8 dB
$E_b/N_0$ required	10.0 dB
Margin	12.8 dB

VII-2-361

## Nd:YAG LASER TECHNOLOGY

The Nd:YAG laser is representative of a class of laser materials known as doped-insulator or doped crystalline lasers. Crystalline yttrium aluminum garnet (YAG, chemical formula  $Y_3Al_5O_{12}$ ), which is a synthetic garnet, doped with the trivalent rare earth ion of neodymium,  $Nd^{3+}$ , was discovered twenty years ago to be an excellent laser material. In the initial experiments it was made to lase in the CW mode, and power outputs in the hundreds of watts have been reported. The crystal structure, however, is usually small (the size of a pencil is large for Nd:YAG) due to slow growth rate, and when operated in a high power mode, the heat generated in the crystal deforms the structure, spoiling the resonant cavity shape in the process. The changed geometry can promote the oscillation of undesired spatial modes or the detuning of the resonance frequency, neither property being conducive to communication applications. Even in the pulsed mode operation, cooling of the laser rod and pump cavity by forced air or liquid (liquid nitrogen in extreme cases) is required. Typical construction of such a laser is illustrated in Figure 2-3.

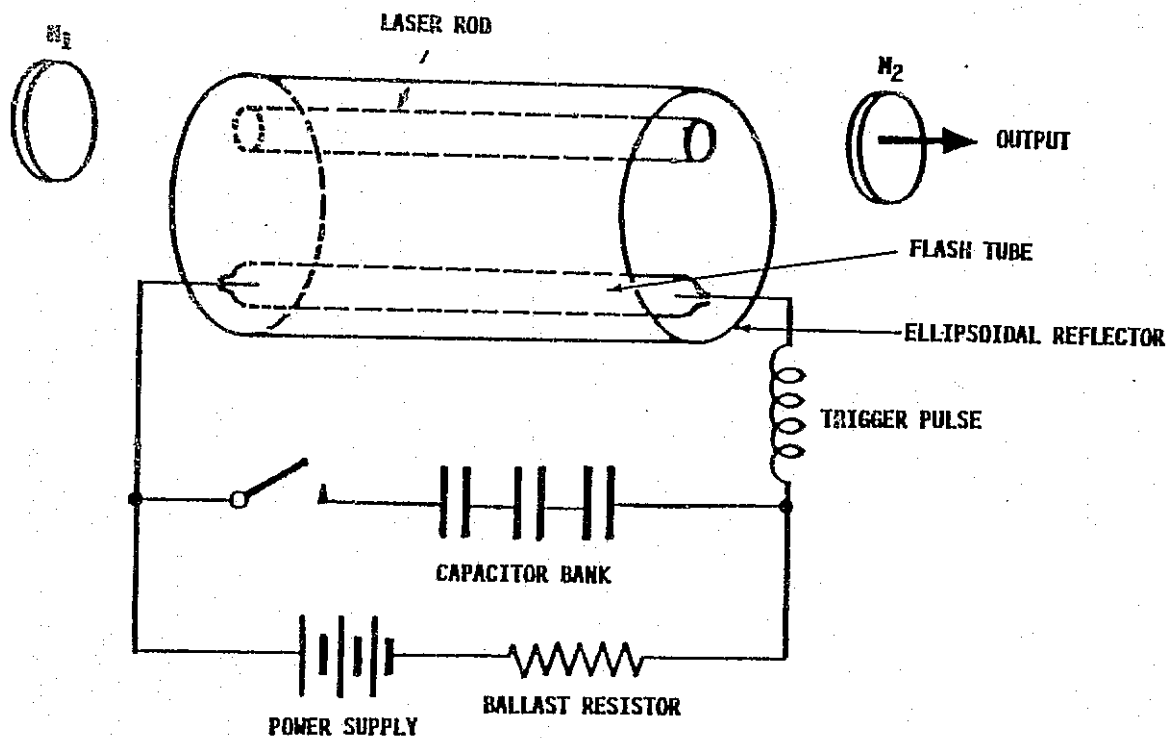

FIGURE 2-3: TYPICAL CONSTRUCTION OF A Nd:YAG LASER SHOWING AN ELLIPSOIDAL REFLECTOR USED TO MAXIMIZE OPTICAL COUPLING BETWEEN THE FLASH-TUBE AND LASER ROD.

ORIGINAL PAGE IS  
OF POOR QUALITY

VII-2-363



STANFORD  
TELECOMMUNICATIONS INC.

Nd:YAG lasers have undergone considerable development in the past twenty years, and probably now outnumber their predecessor, the ruby laser, in applications. Commercial Nd:YAG lasers operate in a pulsed mode that is achieved by mode-locking or Q-switching. Q-switching is a process by which the Q (quality factor) of the cavity is changed periodically, for example by rotating the mirror at one end of the cavity so that it is only resonant when it passes through parallel alignment with the opposite mirror. A second method is to use an electrooptic or acoustooptic shutter to block one mirror periodically. The blockage or nonresonant condition is the low Q state. During the time that the blockage is in effect the round trip gain within the cavity is low ( $\ll 1$ ), and the population inversion (i.e., the placing of the crystal molecules in the appropriate excited energy state) grows under the pumping action without inducing lasing. When the Q is switched high again, the gain exceeds 1 and the medium lases. The rapid lasing transitions deplete the inverted population quickly and all the stored energy is released in a giant pulse. This output is in strong contrast to the spiky waveform generated by pulse-pumping a crystal within a fixed Q cavity.

Q-switching by these reflection modulation techniques can produce pulses as short as 10  $\mu$ s, and other techniques are available to get the pulses down to 1-2  $\mu$ s. Pulse repetition rates in the kHz range are common. To produce pulses short enough and at high enough repetition rates for 100 Mbps-1 Gbps data rates requires mode locking.

Typical profile of the parameters and their variation for a Q-Switched laser are depicted in Figure 2-4.

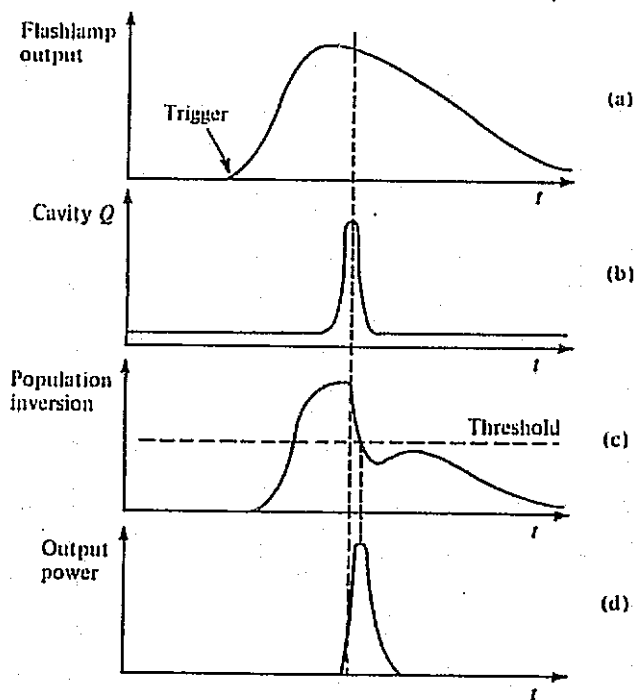

FIGURE 2-4: Schematic representation of the variation of the parameters (a) flashlamp output, (b) cavity  $Q$ , (c) population inversion and (d) output power as a function of time during the formation of a Q-switched laser pulse.

ORIGINAL PAGE IS  
OF POOR QUALITY



STANFORD  
TELECOMMUNICATIONS INC.

V11-2-365

Mode locking is a technique where by the oscillation of multiple longitudinal modes is controlled in a phase coherent fashion such that the waves superpose into a pulse. The longitudinal, or axial, modes of the laser are those for which the round trip length of the cavity ( $2L$ , where  $L$  is the cavity length) equals an integral number of wavelengths, i.e.,  $f_n = nc/2L$ , where  $n$  is the mode index and  $c$  is the propagation velocity within the cavity. If the cavity is long and the laser material gain curve is wide enough above the lasing threshold, many of these modes will oscillate simultaneously, and if phase-locked, will superpose coherently to form a narrow pulse. (This result is predictable by Fourier analysis, which shows that a group of equal amplitude, uniformly spaced, in-phase lines add up to a  $(\sin Nx)/(N \sin x)$  pulse shape). The pulse width is inversely proportional to the number of coherently oscillating modes. Mode locked and now mode locked outputs are shown in Figure 2-5.

Mode locking is accomplished by inserting an electrooptic or acoustooptic crystal modulator into the cavity and driving it with an appropriately phased voltage. Mode lock maintenance is quite sensitive to proper phasing of the modulator phase and the laser oscillations. Feedback circuits can maintain the relative phasing so that mode-lock is not lost. But without additional control the pulse rate out of the laser can vary. The pulse rate is simply the round trip transit time  $c/2L$ ; heating, mechanical vibration etc., can cause  $L$  to change and induce prf variation. If these variations are sensed, they can be compensated by cementing one mirror to a piezoelectric mount which will nudge the mirror in the axial direction in response to an applied control voltage.

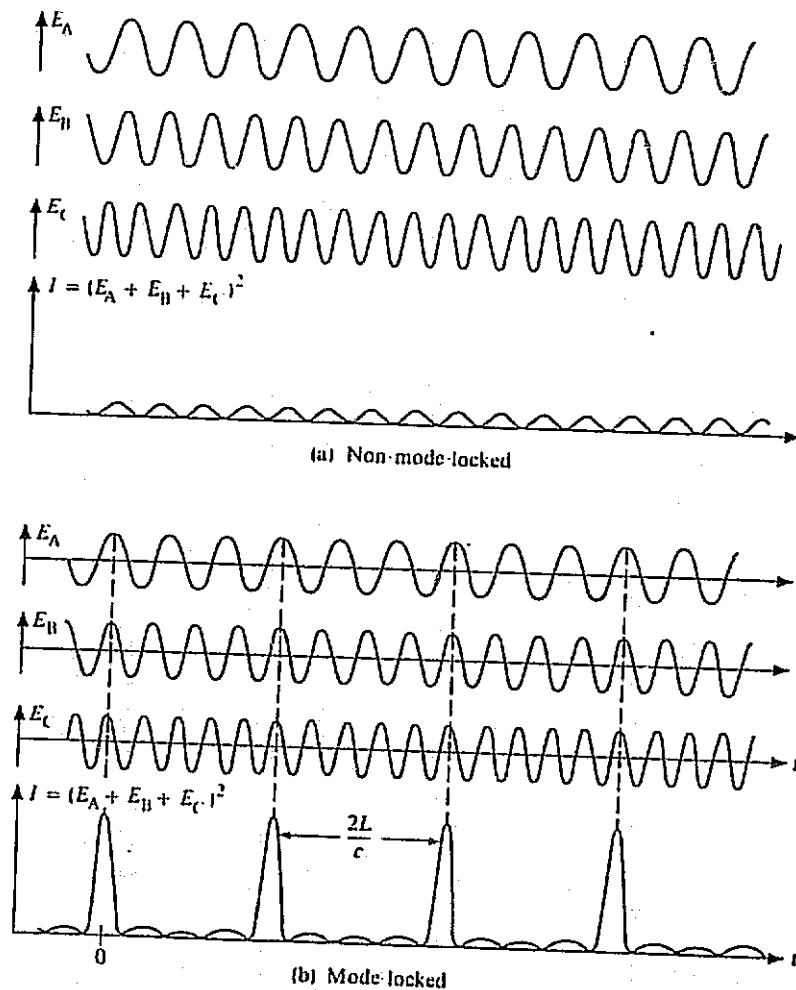

FIGURE 2-5: Comparison of non-mode-locked and mode-locked outputs. In part (a), the phases are random and the instantaneous power is never large. In part (b), all the cosine waves have the same phase at  $t = 0$ . The narrow pulses are spaced  $2L/c$  in time, the round-trip time for light in the cavity.





The natural resonance of Nd:YAG is in the IR at 1.06  $\mu\text{m}$ . In many of its applications it is used in the frequency doubled (FD) mode at 530 nm, the doubling being accomplished by second harmonic generation in a nonlinear optical material (e.g., quartz, rubidium or other alkali metals) into the cavity. From a communicator's viewpoint, doubling is a two-edged sword; quantum detector characteristics are superior at 530 nm (lower noise), but signal power is of course lost in the nonlinear conversion (lower signal).

In the early 1970's, the U.S. Air Force undertook development of a 1 Gbps Nd:YAG laser program. The initial work was performed at the Air Force Avionics Laboratory (1971-1972), and in 1973 McDonnell Douglas Astronautics Co. and Lockheed Missiles and Space Co. were awarded contracts for brass-board development. Since 1975, McDonnell Douglas has continued this development under the name LASERCOM (see Figure 2-6). Contemporaneously, NASA was developing the CO<sub>2</sub> laser to be discussed in a later section.

The demonstration program has proceeded through the successful testing of the laser in an air-to-ground experiment. A 1 Gbps FD Nd:YAG laser mounted in a C-135 transport has communicated from 37,000 ft to a terminal at the White Sands Missile Range. A ground-to-air low data rate uplink (100 to 20,000 bps) at 1.06  $\mu\text{m}$  is also included. Early plans for a space test were scrubbed or delayed for the air-to-ground test. The state of future planning is difficult to discern because of security issues.

In the late 1970's McDonnell Douglas successfully bid the Nd:YAG laser for a 1 Mbps satellite link in a classified program. The competition was a GaAs laser by Hughes Aircraft Co. This effort is now reported to be in demonstration phase.

It is the two efforts cited above that form the technological base for Nd:YAG as a TDAS crosslink candidate. In the remainder of the section we will review the available technical information that is relevant to the laser's use in TDAS.

FIGURE 2-6: Nd:YAG DEVELOPMENT TIMELINE

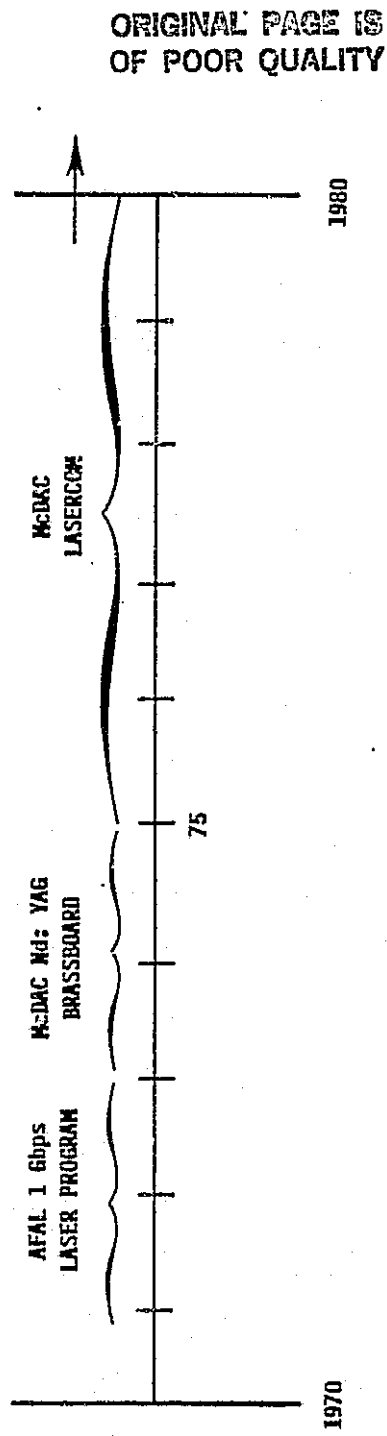

A published description of the space test version of LaserCom gives parameters of interest. Implementations using two different pump mechanisms have been built. A potassium-rubidium (K-Rb) lamp-pumped unit produces 270 mW average power at 250 W input; a solar-pumped unit aimed at ultimate space application can achieve over 400 mW output. Pump lifetime is an issue for the TDAS application. The K-Rb pump has shown less than a 1-year lifetime in testing; no data is available on the solar pump. The laser output in each case is a mode locked 532 nm pulse train at 500 Mpps having 300 ps pulse widths ( $1/e^2$  intensity points). In the discussion of the modulator we shall see how this supports 1 Gbps. Cooling of the rod and pump is by conduction and radiation to minimize weight and power consumption.

Frequency doubling is achieved by a single crystal of  $Ba_2Na(NbO_3)_5$  within the cavity. By coupling an acoustooptic transducer to it the frequency doubling is accomplished. It is not evident that any pulse rate control is employed.

Data is encoded into pulse quaternary modulation (PQM) which is a combination of pulse position and pulse polarization modulation. Each pulse out of the modulator occupies one of two possible slots and carries one of two orthogonal linear polarizations. In this manner each pulse represents two bits and the 500 Mpps laser supports a 1 Gbps data rate. This is shown in Figure 2-7.

ORIGINAL PAGE IS  
OF POOR QUALITY

FIGURE 2-7: PULSE QUATERNARY MODULATION (PQM)

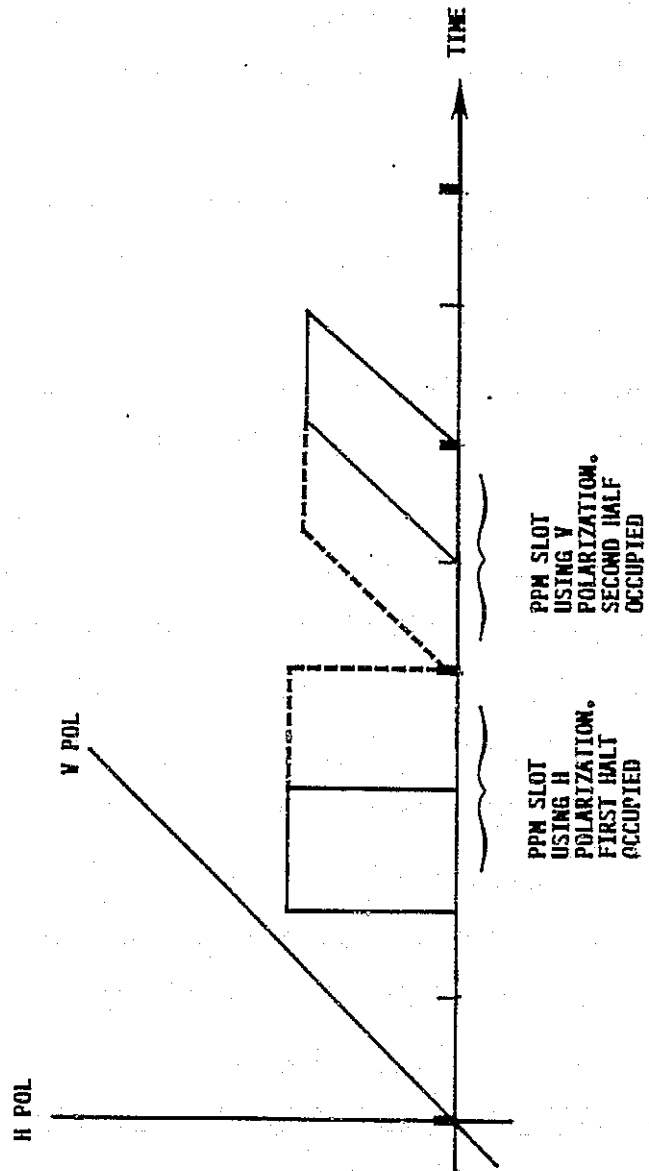

Figure 2-8\* shows the PQM modulator. The 1 Gbps data source is demultiplexed into two 500 Mbps streams. One of these streams (delayed by 1 ns) drives modulator No. 1, which takes in the 500 Mpps horizontally polarized laser pulse train and outputs the pulses with horizontal or vertical polarization according to whether the data is 0 or 1. Each pulse then enters a device that passes vertical polarization undelayed, but delays horizontal an additional nanosecond. Finally, modulator No. 2 takes in the pulse and adjusts its polarization as did modulator No. 1. As a result, the two bits driving the modulators are jointly encoded into one of four orthogonal states (two polarizations  $\times$  two delays). Modulator No. 1 operates at 500 Mpps, but No. 2 must be able to switch at 1 Gbps rates. The modulator assembly is estimated to require 75 W.

Because of the frequency doubling, both photomultiplier tubes (PMT) and avalanche photodiodes (APD) are usable detectors. After extensive consideration a dynamic crossed field photomultiplier (DCFP) was selected for the baseline detector. The structure of the device keeps delay dispersion small in the secondary electron emissions and as a result bandwidths well in excess of 1 GHz are available. The quantum efficiency,  $\eta$  (photoelectrons produced per incident photon), is 0.25-0.30, with  $\eta = 0.40$  predicted. Excess photomultiplication noise is only 1 or 2 dB, implying that the system can operate about 6 or 8 dB from the quantum limit. The photomultiplier gain is sufficient to mask any thermal or dark currents occurring subsequently.

The communications receiver described by Ross et al does not employ the optimum detection strategy for PQM; the reason for this is not obvious since the optimum receiver appears to be simpler than theirs. For strong signals there is not much performance difference anticipated. Nonideal behavior creeps into the detection scheme because of the modulator extinction ratio, which is the ratio of the desired to undesired polarization components in the modulator output. From curves in the reference, it seems reasonable to assume a 1 dB nonorthogonality degradation due to extinction.

---

\* From M. Ross et al, Space Optical Communications with the Nd:YAG Laser, Proc. IEEE Vol. 66, No.3; March 1978.

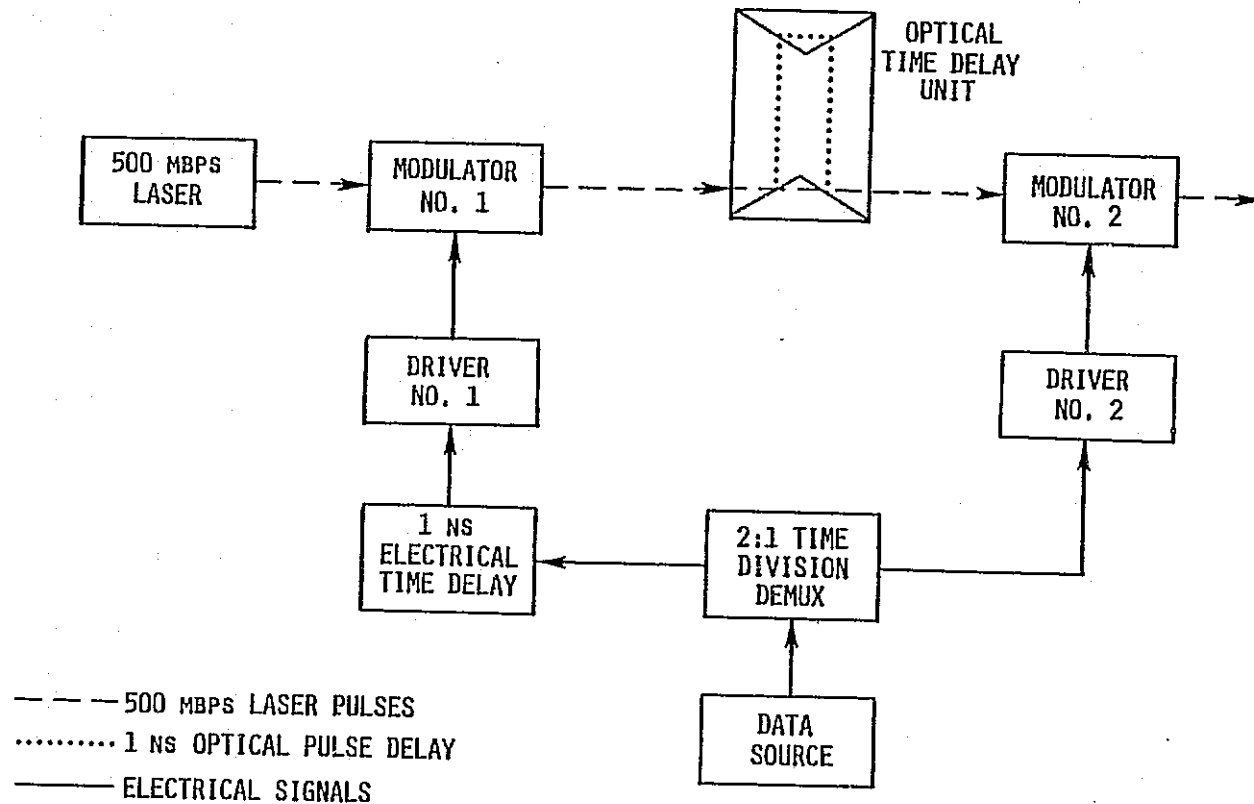

FIGURE 2-8: PQM modulator block diagram. The 1 Gbps data stream is demultiplexed into two 500 Mbps streams. One of these drives the linear polarization state of the modulator No. 1 ( $H = 0, V = 1$ ). That output is delayed or not delayed (by 1 ns) according to its polarization, following which the polarization state is once again controlled by modulator No. 2. The result is a 4-state output in which each pulse (at 500 Mbps) conveys two bits.



STANFORD  
TELECOMMUNICATIONS INC.

A representative link budget is shown in Figure 2-9. Using the apertures given in Ross (20 cm transmit, 60 cm receive) and conservative values of the other parameters (e.g., 270 mW laser output,  $\eta = 0.2$ , 2 dB excess noise) the link closes with almost 15 dB margin. More optimistic values of these might yield another 5-6 dB. In the latter event, there is room to substantially decrease the apertures, especially at the receiver where nondiffraction limited operation is permissible. If the receive aperture is cut to 20 cm, 9.5 dB of margin is sacrificed. The link cannot tolerate another 12 dB loss in reduction of both transmit and receive apertures to 10 cm, a more satisfying value.

## FIGURE 2-9: Nd:YAG CROSSLINK BUDGET

Transmitter Power (270 mW)	-5.7 dBW
Optics Efficiency (70%)	-1.5 dB
Transmit Gain (20 cm, 75% eff.)	121.5 dB
Path Loss (162° separation, synchronous)	-305.8 dB
Receive Gain (60 cm)	131.1 dB
Pointing Loss	-0.3 dB
Data Rate <sup>-1</sup> (1 Gbps)	-90.0 dBs
Received Energy/Bit (Eb)	-150.7 dBJ
Planck's Constant	-331.8 dBWs <sup>2</sup>
Frequency (564 THz)	147.5 dBs <sup>-1</sup>
Detector Quantum Efficiency <sup>-1</sup> ( $\eta = 0.2$ )	7.0 dB
Excess Photomultiplication Noise <sup>-1</sup>	2.0 dB
Received Energy/Detected Photon	-175.3 dBJ
Detected Photons/Bit available	24.6 dB
Detected Photons/Bit required (10) (@ 1 dB extinction ratio degradation)	10.0 dB
Margin	14.6 dB





The technology used in Nd:YAG systems was known in the mid 1960's and well established by the mid 1970's. There appear to be few areas in which substantial progress is awaited. The advent of GaAs diode pumps for the Nd:YAG may, however, go a long way to overcome the lifetime uncertainties of lamp or solar pumps. The modulator is complex and somewhat sensitive. We are not aware of new work in modulator technology for YAG, although there may be some going on in classified programs.

Weight and power estimates from Ross et al (Figure 2-10) indicate that spacecraft transmitter would required 250 lbs, 400-650 W, and for the receiver, the burden is 265 lbs and \_\_\_ W. We do not yet have available an estimate of the burden for the required user signal demodulator, buffer, and multiplexer.

FIGURE 2-10

WEIGHT AND POWER FOR SPACE-TEST Nd:YAG LASER SYSTEM

TRANSMITTER

<u>ITEM</u>	<u>AVERAGE POWER (W)</u>
Laser and Control	273.1
Modulator/Driver	70.5
Electronics Processing	149.4
Solar Collector Assembly	30.0
Tracking Assembly	48.0
Power Supply Conditioner	167.0
<hr/>	
TOTAL	738.0 W
Estimate for Operational System	400-650 W
<u>ITEM</u>	<u>WEIGHT (LBS)</u>
Laser/Modulator	36.3
Electronics	74.8
Telescope	15.0
Solar Collector	55.0
Tracking	59.8
Support Structure	48.0
Power Supply, Conditioner	58.1
<hr/>	
TOTAL	347.0 lbs.
Estimate for Operational System	250 lbs.

	<u>WEIGHT (lbs)</u>	<u>POWER (W)</u>
Transmitter	250	650
Receiver	270	
<hr/>		
TOTAL	520 lbs	

## CO<sub>2</sub> LASER TECHNOLOGY

CO<sub>2</sub> lasers for space communication were being touted in the mid-to-late 1960's. Considerable work on these had earlier been undertaken at Hughes Aircraft Company (HAC) and NASA/GSFC. After a proposal to fly a laser system on NASA's ATS-F was turned down due to budgetary constraints, NASA undertook in 1970 a program to complete the development of the CO<sub>2</sub> laser technology for space applications so that a convincing case for its future use would be established. In the six years that followed, CO<sub>2</sub> technology was brought to the state of the art in that program, and basic technical feasibility of a space-to-space link was established. The NASA investigators envisioned an "advanced TDRS" (ATDRS) space communication network in which an East satellite transmitted a CO<sub>2</sub> laser crosslink to a West, and both satellites received user spacecraft return link data via a CO<sub>2</sub> link. Data downlinked from the West satellite was received at an earth station and distributed to experimenter sites via domsat. Clearly the vision at that time had much in common with the current perception of TDAS.

Following the completion of this program, government funding for additional CO<sub>2</sub> laser efforts for space applications diminished in favor of military research and development in laser rangefinders. Work in CO<sub>2</sub> radar continues, but because of its significantly different orientation seems to have had little spinoff in areas that would bolster space-qualified technology. Along the way some of the prime resources (e.g., HAC) for continuing the space applications were lost to the community.

In consequence, today's CO<sub>2</sub> laser technology for space data systems is largely 1975's technology. In order to appreciate what that technology is, we begin with a fundamental discussion of CO<sub>2</sub> lasers and incorporate the technical elements as they arise.

ORIGINAL PAGE IS  
OF POOR QUALITY

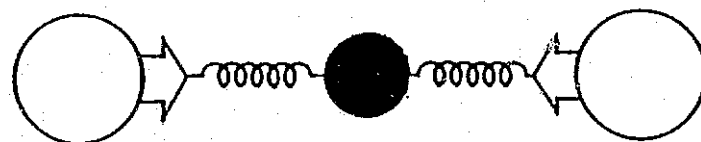

$$\text{FREQUENCY}_1 = 4 \times 10^{13} \text{ Hz}$$

(a) SYMMETRIC STRETCH

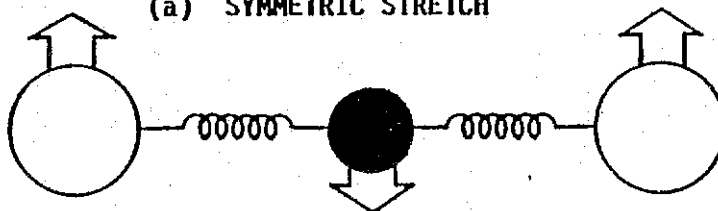

$$\text{FREQUENCY}_2 = 2 \times 10^{13} \text{ Hz}$$

(b) BEND

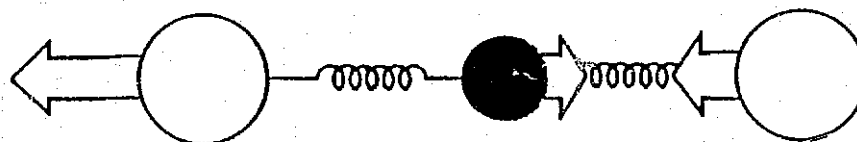

$$\text{FREQUENCY}_3 = 7 \times 10^{13} \text{ Hz}$$

(c) ASYMMETRIC STRETCH

KEY:



CARBON



OXYGEN

FIGURE 2-11: VIBRATIONAL MODES OF THE CO<sub>2</sub> MOLECULE

VII-2-379



STANFORD  
TELECOMMUNICATIONS INC.

The active medium in the laser is the CO<sub>2</sub> gas molecule. This fact leads to some immediate distinctions between this and the Nd:YAG laser just discussed. In the latter, transitions between energy states of ions (atoms or molecules that have lost outer shell electrons) induces lasing action; for CO<sub>2</sub>, it is transitions in vibrational states of the molecule that produces the coherent radiation. It is not hard to imagine that the resonances of these vibrations are slower than the actions involved in ion energy state transitions (which usually occur in the visible or UV), and correspondingly evidence longer wavelengths. There are two lasing transitions in CO<sub>2</sub>, at 9.6 μm and 10.6 μm, the latter being the stronger. If the CO<sub>2</sub> molecule covalent bonding is pictured as the linear structure O=C=O, the 10.6 μm line results from an "end-on" collision of the molecules that changes its oscillation from an asymmetric stretch along the molecular axis (O atoms out of phase in their vibrations relative to C) to a symmetric, or in-phase, stretch. (The 9.6 μm line arises from "broadside" collisions that convert the asymmetric stretch into a bending mode resembling the vibrating string.) Vibrational modes are depicted in Figure 2-11.

The pumping mechanism for CO<sub>2</sub> is molecular collisions (i.e., gas discharge) induced by a high voltage pulse across the sealed tube. To improve the lasing action, H<sub>2</sub> and Ne replace 90% of the CO<sub>2</sub> and give rise to collisions at the proper energy levels to stimulate population inversion. An increase in pressure does two important things: first, it increases the frequency of collision and thus enhances the output level; the second thing makes it possible to impress wideband modulation on the laser light. To appreciate the latter point requires some discussion of modulation mechanisms for CO<sub>2</sub> lasers.

FIGURE 2-12: LASER MODULATORS

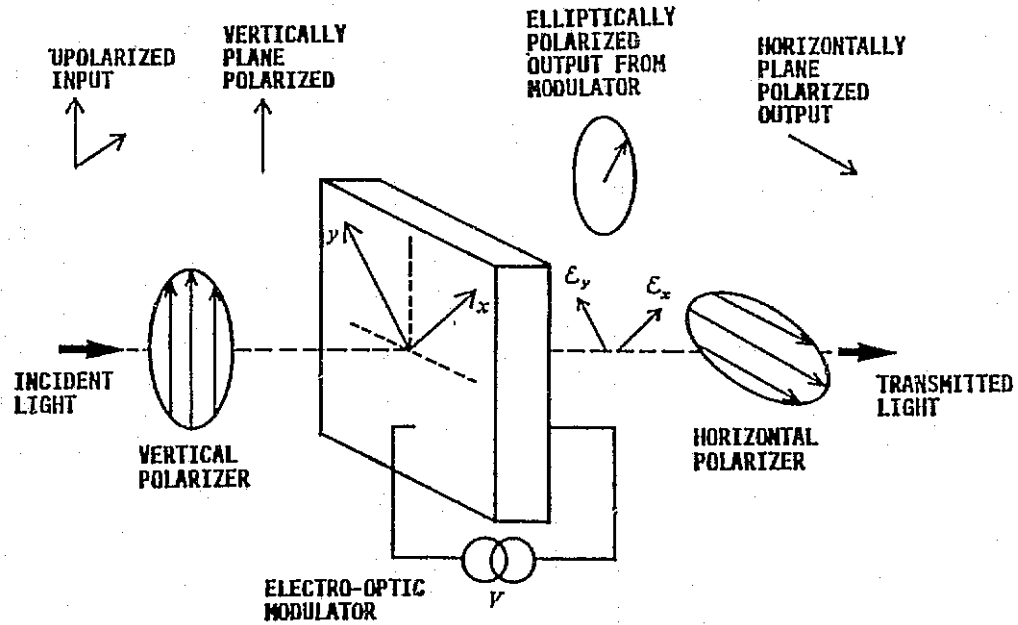

(a) POCKEL'S CELL MODULATOR, EXAMPLE OF AN EXTERNAL MODULATOR.

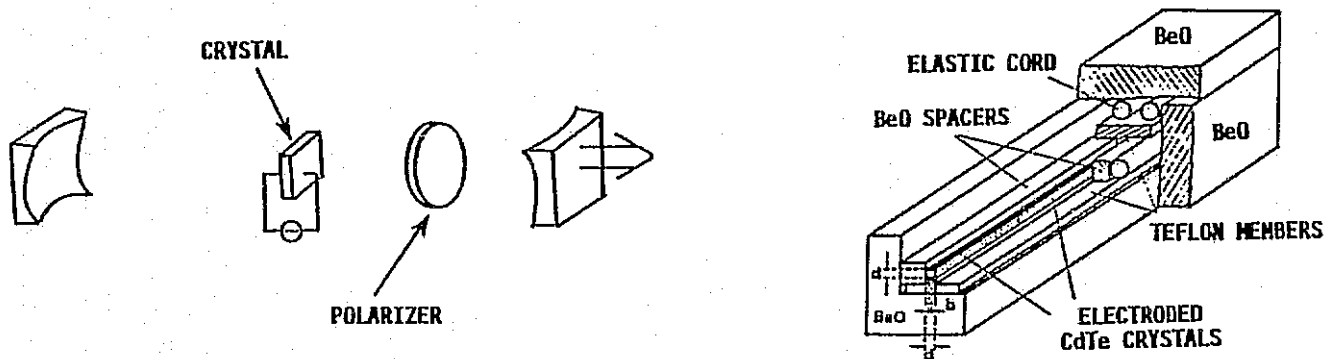

(b) INTERNAL MODULATOR USING A BIREFRINGENT CRYSTAL AND A POLARIZER.

(c) AN EXTERNAL MODULATOR BUILT BY THE ESA FOR A 1 Gbps CO<sub>2</sub> LASER

ORIGINAL PAGE IS  
OF POOR QUALITY

Many lasers (see Figure 2-12) are modulated by external modulators; these lie outside the laser cavity and impress modulation on the narrowband optical carrier emanating from the laser cavity. Such modulators have the advantage that they do not interfere with the coherent light generation process. Other modulators operate inside the cavity and are dubbed internal modulators. Internal modulators, most notably the technique called coupling modulation, in which the voltage controlled birefringence of a crystal can rotate the polarization of the light and thereby control the amount of light coupled out of the cavity through a polarizer, suffer bandwidth limitations due to their interaction with the cavity field. Nevertheless, coupling modulation has been prominent for CO<sub>2</sub> lasers because of the high voltages required for external modulators. In order to achieve broadband internal modulation, it is necessary to broaden the source bandwidth, and this is where the gas pressure comes in. Besides the inherent doppler broadening that occurs because of the natural velocity distribution of the gas molecules and their projections along the axial direction, there is collision broadening that arises from the interruption of radiation due to collisions. As the gas pressure increases and collisions become more frequent, the radiation from a molecule shows large (essentially random) phase shifts at its collision times, and these broaden the observed spectral line.

The difficulty related to internal modulation is that the high pressures required for broadband modulation cause problems with the pressure seals in the tube; leaks are a major source of shortened lifetime for the CO<sub>2</sub> laser.

More recently, technological progress in external modulators has advanced to a point that may ameliorate this problem. Research at MIT Lincoln Laboratory and the European Space agency has produced external modulators capable of Gbps operation. Despite this promise, other difficulties with CO<sub>2</sub> lifetime exist. One of these is the chemical reaction within the sealed enclosure that converts CO<sub>2</sub> to CO. It is hoped that replacement of the high voltage dc pumping by RF pumping techniques will increase CO<sub>2</sub> laser reliability, but this is yet unproven at a level required for space operations and constitutes a major drawback to the use of CO<sub>2</sub> laser for TDAS.

Because the wavelength of the CO<sub>2</sub> is at least a factor of 10 greater than that of the other lasers under consideration, it gets the least benefit of all in gain from a fixed aperture. Fortunately, CW power generation in a CO<sub>2</sub> laser can more than compensate for this. At least 10 W CW has been achieved. But laser lifetime at high power levels (15,000 hrs) is not yet adequate for an operational space system. Whether a lower power system can suffice depends on further developments in detector technology: With everything else equal, an increase in frequency from  $f$  to  $nf$  brings about a gain of  $n$  in the signal-to-noise ratio of a quantum-limited heterodyne system, after an adjustment for quantum efficiency (see Figure 2-13).

PRECEDING PAGE BLANK NOT FILMED



FIGURE 2-13: EFFECT OF A CHANGE OF FREQUENCY ON SIGNAL-TO-NOISE RATIO

$$\begin{array}{c}
 \text{transmit gain} \\
 \left. \frac{S/N}{S/N} \right)_{nf} = \frac{n^2 \times n^2}{n^2 \times n} \left( \frac{\eta_{nf}}{\eta_f} \right) = n \left( \frac{\eta_{nf}}{\eta_f} \right) \\
 \left. \frac{S/N}{S/N} \right)_{n} \\
 \text{path loss} \qquad \qquad \qquad \text{noise power density} \\
 \text{receive gain}
 \end{array}$$

ORIGINAL PAGE IS  
OF POOR QUALITY

VII-2-385



STANFORD  
TELECOMMUNICATIONS INC.

Photon detection at IR wavelengths is an inherently inefficient process. The low energy per photon constrains the maximum energy (the gap between the photon energy and the detector surface work function) that an emitted photoelectron can have. Inelastic collisions of freed electrons with the material reduce their energy and may prevent their escape at all. Thus the yield (emitted photoelectrons per incident photon), which is the material quantum efficiency, may be two or three orders of magnitude shy of ideal. Quantum efficiency is the prime performance characteristic for a direct detection receiver, and so direct detection becomes a poor prospect for CO<sub>2</sub>. Heterodyne detection, while unable to overcome poor quantum efficiency, can permit operation fairly near the quantum limit if the LO field strength is such that the signal photoelectrons dominate thermal noise. For reference, we note that the effective noise power spectral density,  $h\nu$  (or  $2h\nu$ , depending on detector type), of an ideal detector at 10.6  $\mu\text{m}$  is -197.3 dBW/Hz, about 7 db higher than equivalent thermal noise ( $kT$ ) at 300°K. When  $h\nu$  is degraded 10 to 30 dB for quantum efficiency, it becomes obvious that even quantum limited operation for CO<sub>2</sub> is quite deficient in noise equivalent power to an RF link; it must, if course, make up for this with transmitted power and antenna gain.

Characteristics of photodetection at IR wavelengths are consolidated in Figure 2-14.

## FIGURE 2-14: PHOTODETECTION AT IR

- QUANTUM EFFICIENCY (QE) LOW BECAUSE OF LOW PHOTON ENERGY
- LOW QE MAKES DIRECT DETECTION POOR
- FOR HETERODYNE, THE NOISE PROCESS LOOKS GAUSSIAN WITH SPECTRAL DENSITY  $N_0 = HF_C$ , WHERE  $F_C$  = CARRIER FREQUENCY
- THE IF SIGNAL-TO-NOISE RATIO FOR HETERODYNE IS 9 DB GREATER THAN THAT OF DIRECT DETECTION IN THE SAME BANDWIDTH

VII-2-387



STANFORD  
TELECOMMUNICATIONS INC.

Many detector types were investigated during the NASA program. Both photovoltaic (PV) semiconductors and extrinsic photoconductors (Figure 2-15) were found to be suitable candidates. An extrinsic photoconductor is a semiconductor that has been impurity doped; absorption of IR increases hole-electron pair production, increases material conductivity, and will generate a corresponding output current when the semiconductor is appropriately reversed biased. In the photovoltaics, pairs generated by photon absorption separate and the charge separation is measured as potential across the open-circuited device.

The low operating temperatures (4 to 30°K) needed to minimize thermal current leaves these at a disadvantage for space applications. Photovoltaics also require cryogenic cooling, but to temperatures around 77-130°K.

At the conclusion of the NASA project, mercury-cadmium-tellurium (HgCdTe) detectors with 3 dB bandwidths of 425 MHz at 10.6  $\mu\text{m}$  were known. (Photoconductors of germanium and silicon with 1.5 GHz bandwidths had been known for some time.) More recent work at Honeywell and Lincoln Laboratory has yielded devices which when cooled to 77°K display 1-2 GHz bandwidths and heterodyne quantum efficiencies from 10 to 25%. There is reasonable expectation that 5 GHz or greater bandwidth may be soon achievable, but perhaps at the sacrifice of equivalent noise power (i.e., quantum efficiency). Thus there is ample evidence that suitable detectors exist for CO<sub>2</sub> heterodyne systems. The technology of long-lived space-qualifiable cryogenic units appears to lag detector technology currently, and is probably one of the casualties of the stagnation in CW CO<sub>2</sub> laser development that set in following the close of the NASA GSFC program.

FIGURE 2-15: PHOTODETECTORS FOR CO<sub>2</sub> LASERS

THERMAL DETECTORS

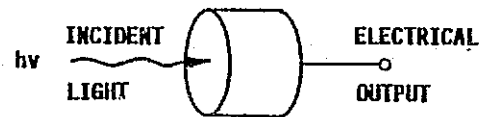

- DETECTOR ABSORBS RADIATION
  - TEMPERATURE INCREASES
  - A TEMPERATURE - DEPENDENT PARAMETER CHANGES VALUE (E.G., ELECTRICAL CONDUCTIVITY)
  - RESPONSE IS FAIRLY BROADBAND
- TYPES
    - THERMOELECTRIC
    - BOLOMETER
    - PNEUMATIC
    - PYROELECTRIC

QUANTUM DETECTORS:

- INCIDENT LIGHT CHANGES ELECTRICAL PROPERTIES

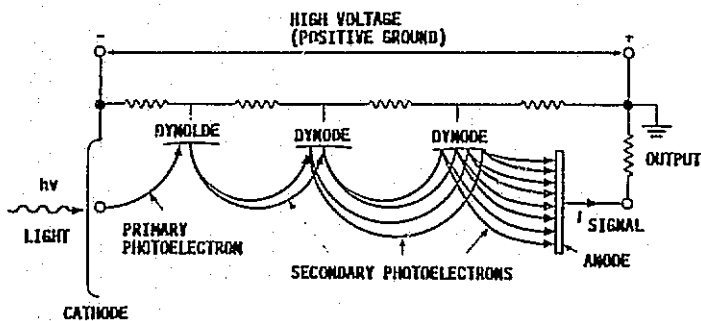

CURRENT AMPLIFICATION IN A PHOTOMULTIPLIER TUBE. EACH DYNODE EMITS MULTIPLE SECONDARY ELECTRONS FOR EACH ELECTRON THAT STRIKES IT.

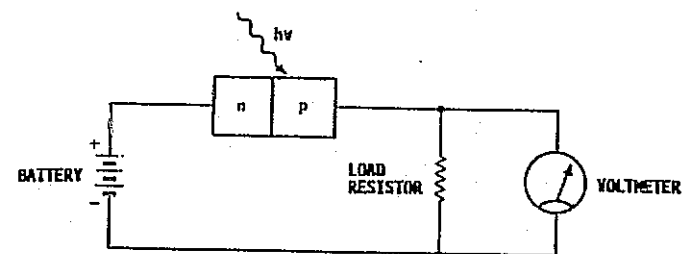

CONSTRUCTION OF A p-n JUNCTION PHOTODIODE DETECTOR. THE PHOTODIODE IS REVERSE-BIASED. WITH NO LIGHT ILLUMINATING THE JUNCTION, CURRENT IN THE EXTERNAL CIRCUIT IS ZERO.

ORIGINAL PAGE IS OF POOR QUALITY

A representative link budget for a CO<sub>2</sub> heterodyne crosslink used in a transponding mode is shown in Figure 2-16. Transmit power of 25 W is assumed. The transmit and receive apertures are 34 cm and 43 cm, respectively. To accommodate worst case loading, 1.8 Gbps data rate is selected. A total of 10.8 dB losses in the transmitter and receiver are taken; these include aperture obscuration by the optics, losses in the reflective and transmissive optics themselves, spatial mismatch between the received (gaussian) field and LO (uniform) field, and detector rolloff. The resulting apertures are large, suggesting that advances in detectors (greater bandwidths and higher quantum efficiencies) are needed to decrease the required apertures. For reasons of pointing accuracy and minimizing the unwieldiness of the optics, an aperture of 50 cm is probably the maximum that should be considered.

## FIGURE 2-16: CO<sub>2</sub> CROSSLINK BUDGET

Transmitter Power (25 W)	14.0 dBW
Transmit Gain (34 cm, ideal)	100.0 dB
Obscuration Loss	-2.9 dB
Optics Loss	-2.0 dB
Path Loss (162° separation, synchronous)	-279.8 dB
Receive Gain (43 cm, ideal)	100.0 dB
Obscuration Loss	-0.2 dB
Optics Loss	-1.1 dB
LO Spatial Mismatch Loss	-1.8 dB
Data Rate -1(1.8 Gbps)	-92.5 dBs
Detector Frequency Mismatch Loss	-1.0 dB
 Received Energy/Bit ( $E_b$ )	<hr style="width: 100%; border: 0.5px solid black;"/> -167.3 dBJ
 Planck's Constant	-331.8 dBWs <sup>2</sup>
Frequency (28.2 THz)	134.5 dBHz
Detector Quantum Efficiency <sup>-1</sup> ( $\eta = 0.2$ )	7.0 dB
Detector Noise Degradation	0.5 dB
 Noise Power Spectral Density ( $N_0$ )	<hr style="width: 100%; border: 0.5px solid black;"/> -189.9 dBW/Hz
 Eb/No available	22.5 dB
Eb/No required	10.0 dB
 <hr style="width: 100%; border: 0.5px solid black;"/> Margin	<hr style="width: 100%; border: 0.5px solid black;"/> 12.5 dB

VII-2-391



McElroy et al\* of NASA GSFC have estimated weight and power for a 1 Gbps homodyne link using similar parameters. Because heterodyne reception requires 3 dB more bandwidth (and the same increase in power), their figures are probably on the low side for the TDAS case. They find that the transmitter consumes 270 lbs, 270 W, and the receiver 170 lbs, 65 W.

The conclusion from a communication performance viewpoint is that the type of crosslink service envisioned for TDAS stands right at the edge of current CO<sub>2</sub> technology. Revolutionary developments are not anticipated in the near term; therefore to make CO<sub>2</sub> a viable candidate would require a push in the areas of laser lifetime and onboard detector cryogenics.

---

\* McElroy, J.H., et al, CO<sub>2</sub> Laser Communication Systems for Near-Earth Space Applications, Proc. IEEE Vol. 65, No.2, Feb. 1977.



## GaAs TECHNOLOGY

Gallium arsenide is the prevalent material in the light-emitting diodes (LED's) in our calculator and wrist watch displays. When the semiconductor diode is forward biased, spontaneous recombination of holes and electrons in the junction region releases radiation in the visible or near-IR region. This emission process can be stimulated by increasing the current flow to produce population inversion and providing a mirrored cavity for feedback. The diode can be its own cavity simply by cleaving it along its intrinsic crystalline planes to attain highly parallel end surfaces; the difference in refractive index between air and the material provides sufficient reflectivity. Because GaAs diodes are small, (barely visible to the unaided eye), lightweight and low in power consumption, they have become the prime object of research interest for laser space communications today. The interest is further spurred by use in fiber optic cable communications, where simple pulsed LED operation is giving way to sophisticated modulation supported by laser sources, with heterodyne receivers and integrated optics repeaters. There is good spinoff coupling between the latter technology and that for space communications.

Schematics of GaAs diodes are presented in Figure 2-17.

PRECEDING PAGE BLANK NOT FILMED

FIGURE 2-17: GaAs LASER DIODES

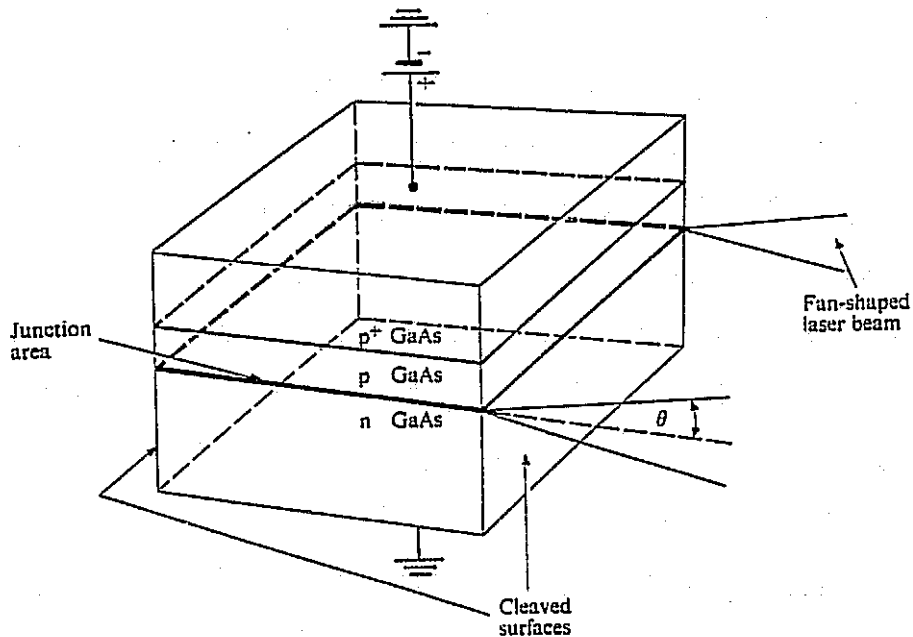

Schematic construction of a semiconductor laser. The emission is confined to the junction region. The narrow width of the junction causes the large half-angle beam divergence  $\theta$ .

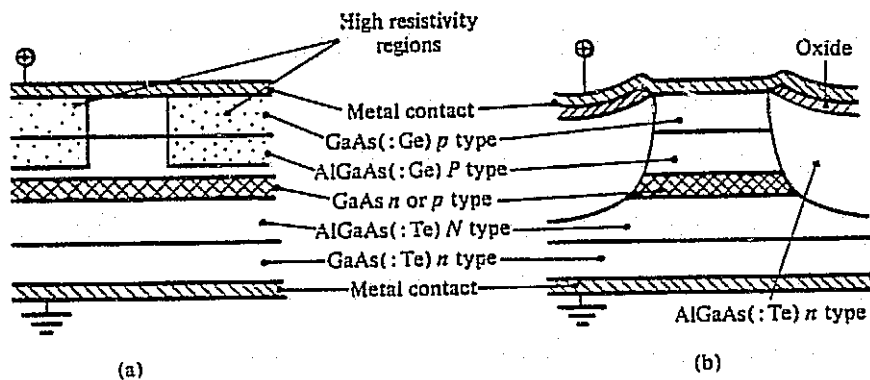

Schematic cross-section (end view) of two typical stripe geometry laser diodes: (a) the stripe is defined by proton bombardment of selected regions to form high resistivity material and (b) the stripe is formed by etching a mesa and then AlGaAs is grown into the previously etched out sides of the active region to form a 'buried stripe' structure.

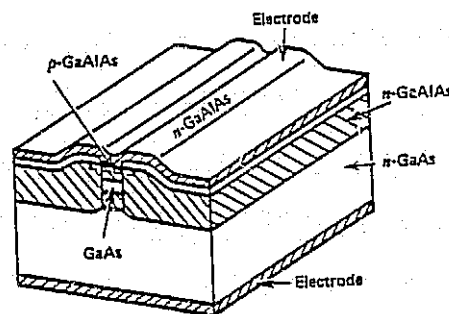

Buried heterojunction laser diode.

The room temperature natural line of GaAs is 890 nm. Negative electron affinity (NEA) photoemissive devices cutoff near or below that wavelength (those detectors made of GaAs itself are good up to near the natural wavelength). Silicon devices (e.g., avalanche photodiodes) cut off around 1.1  $\mu\text{m}$  and have better response with decreasing wavelength. Then there is interest in being able to tune the diode output to a lower frequency. This can be done by cooling ( $\lambda = 850 \text{ nm}$  at 77°K), which brings another benefit: increased average output power. An alternative that is superior in both respects, however, is use of heterojunction (or heterostructure) diodes. The introduction of a mole fraction  $X$  of the impurity Al to replace some Ga ions creates a ternary compound denoted  $\text{Ga}_{1-X}\text{Al}_X\text{As}$  which has a shorter wavelength (around 830 nm).

Detector requirements for GaAs lasers are listed in Figure 2-18, as are quantum efficiency profiles.

FIGURE 2-18: DETECTOR REQUIREMENTS

- HIGH SENSITIVITY
- WIDE BANDWIDTH
- SMALL ADDITIONAL NOISE
- STABLE CHARACTERISTICS
- MODERATE SOURCE VOLTAGE

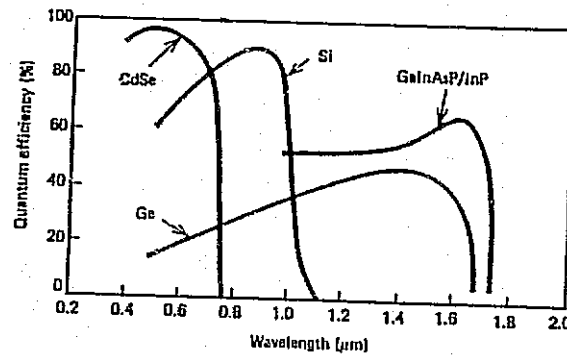

QUANTUM EFFICIENCY AS A FUNCTION OF THE WAVELENGTH FOR VARIOUS PHOTODIODE MATERIALS

ORIGINAL PAGE IS  
OF POOR QUALITY

VII-2-397



STANFORD  
TELECOMMUNICATIONS INC.

Two materials are used in forming the junction of a heterostructure device, most commonly GaAs and a doped variant, GaAlAs. Important consequences are higher lasing efficiency and lower threshold current. A type known as double heterostructure carrier these improvements further by confining the radiation more strictly to the junction region. Continuous operation of double heterostructure diodes, at room temperature is possible with tens of mW output at hundreds of mA current. Among the commercial leaders in developing the heterostructure laser diode is RCA.

An issue of concern for GaAs diodes is power generation. Recent work at M.I.T. Lincoln Laboratory demonstrates 25 mW CW from a single diode. Work on power combining of diode arrays is underway at Perkin-Elmer, Lincoln Laboratory, Xerox and a number of the aerospace companies. Output, of several hundred mW have been claimed. Both coherent and intensity (noncoherent) combining are being studied, but status of the efforts is difficult to obtain due to matters of security. There are nontrivial issues to face in power combining, one being maintaining constant frequency of the diode outputs. For an array deposited on a single chip this can be accomplished by temperature control. In any event, combining schemes must be evaluated critically because an increase in output power is not sufficient. It is increased brightness (spatial power density) that will bring about a stronger link. If the increased power is angularly dispersed, the sought-after improvement will not be found. Passive schemes that claim to increase brightness are flirting with the second law of thermodynamics in promising decreased entropy (in the spatial modes) for no work done. Nevertheless, it seems reasonable to assume that some progress will be shown in this area.

Figure 2-19 shows a link budget for a GaAlAs heterodyne system. With the indicated apertures, 1 W can support the 1.8 Gbps crosslink.

## FIGURE 2-19: GaAs HETERODYNE DETECTION CROSSLINK BUDGET

TRANSMITTER POWER (1W; 40 DIODES @ 25 mW EACH)	0.0 dBW
TRANSMIT GAIN ( 25.0 cm, IDEAL)	119.6 dB
OBSCURATION LOSS	0.0 dB
OPTICS LOSS	-0.2 dB
PATH LOSS (162° SEPARATION, SYNCHRONOUS)	-301.9 dB
RECEIVE GAIN (25.0 cm, IDEAL)	119.6 dB
OBSCURATION LOSS	0.0 dB
OPTICS LOSS	-0.2 dB
LO SPATIAL MISMATCH LOSS	-1.8 dB
DETECTOR BANDWIDTH <sup>-1</sup> (1.8 GHz)	-92.5 dBs
DETECTOR MISMATCH LOSS	0.0 dB
RECEIVED ENERGY/Hz ( $E_h$ )	-157.4 dBJ
PLANCK'S CONSTANT	-331.8 dBWs <sup>2</sup>
FREQUENCY (361.4 THz)	145.6 dBHz
DETECTOR QUANTUM EFFICIENCY <sup>-1</sup> ( $\eta = 0.6$ )	2.2 dB
DETECTOR NOISE DEGRADATION	1.0 dB
NOISE POWER SPECTRAL DENSITY ( $N_o$ )	-183.0 dBW/Hz
$E_h/N_o$ AVAILABLE	22.5 dB
$E_h/N_o$ REQUIRED	10.1 dB
MARGIN	12.4 dB



**STANFORD  
TELECOMMUNICATIONS INC.**

The TDAS space technology is comprised of the TDAS S/C and the TDAS user S/C technologies. In order to realize an effective TDAS design for the 1990's, R&D efforts are needed in these two areas. In the chart the user S/C R&D components previously identified for unique R&D efforts are listed. There is cross fertilization of technology R&D efforts between the user S/C and TDAS S/C components (with the exception of the on-board tape recorder). For each component the chart lists the user S/C technology R&D output and it's cross fertilization impact on the TDAS S/C. Cross fertilization is beneficial; however, its existence certainly does not eliminate the need for specific R&D efforts for the TDAS S/C in favour of TDAS user S/C R&D efforts (or vice versa). Even for generically equivalent Subsystems on the TDAS S/C and the user S/C, individual and unique technology R&D efforts will be required for each spacecraft because of their unique requirements for each subsystem.

## CROSS FERTILIZATION OF TECHNOLOGY R&D

### R&D COMPONENT

### TDAS USER S/C

### TDAS S/C

60 GHZ HIGH  
POWER AMPLIFIER  
(HPA)

DEVELOPMENT WILL PROVIDE REQUIRED  
RF POWER SOURCE

WILL PROVIDE POWER SOURCE  
FOR

- CROSS LINK
- WSA SUBSYSTEM

ANTENNA SUBSYSTEM

PROVIDE CAPABILITY OF TRANSFERRING  
HIGH RATE USER DATA ON 60 GHZ  
SINGLE ACCESS CHANNELS

FOLLOWING AREAS OF WSA  
SUBSYSTEM WILL GET  
DEVELOPMENT BOOST

- WSA ANTENNAS
- ANTENNA POINTING &  
CONTROL SYSTEM
- AUTOTRACKER

ON-BOARD COMPUTER (OBC)

ENHANCED OBC REQMTS OF FUTURE TDAS  
USER S/C WILL BE MET

SAME DEVELOPMENT WILL  
HELP RESOLVE TECHNOLOGY  
ISSUES RELATED TO

- MEMORY
- SPEED
- ACCURACY
- LIFE

ATTITUDE CONTROL SYSTEM  
(ACS)

DEVELOPMENT WILL ENHANCE ACCURACY  
AND ALLOW EXPERIMENTS REQUIRING  
HIGH POINTING PRECISIONS TO BE  
PERFORMED

ACS ACCURACY IS IMPORTANT  
FOR TDAS DUE TO DESIRABLE  
POSITIONAL ACCURACY OF  
MBA

ON-BOARD TAPE RECORDER

← NO CROSS FERTILIZATION →



STANFORD  
TELECOMMUNICATIONS INC.



SUMMARY

The subsystem unique technology R&D efforts in support of the TDAS user S/C and the TDAS S/C, which is the space segment of TDAS for the 1990's have been assessed. This technology assessment was made in relation to mission models, what is reasonable to expect from a technology viewpoint and what are the key technology drivers. Each identified subsystem was addressed on the basis of breaking it down into key components; for each component, the technology issues and the R&D efforts needed to resolve the issues were identified. Subsequently, based upon experience accumulated in the past in the NASA and Industrial Sectors and the ongoing development activities taking place elsewhere, additional subsystem unique R&D efforts needed were identified. Maintenance of these R&D efforts at an adequate level will allow the development of enabling technologies in support of the TDAS to be used in the 1990's.

2.5

CONCLUSIONS

The conclusions of the Space Segment Technology Assessment task are listed.

PRECEDING PAGE BLANK NOT FILMED

## CONCLUSIONS

- OUR TDAS DESIGN PUTS LEAST REQUIREMENTS ON USER S/C
- RECOMMENDED R&D SHOULD BE INITIATED TO ACHIEVE ENABLING TECHNOLOGIES FOR BOTH USER S/C AND TDAS S/C
- NO AREAS OF CONCERN ARE FORESEEN IN USER S/C OR TDAS S/C
- TDAS USER S/C R&D CROSS FERTILIZES TDAS R&D (EXCEPT IN CASE OF ON-BOARD TAPE RECORDER)
- CROSS FERTILIZATION BETWEEN TDAS USER S/C AND TDAS S/C ALTHOUGH BENEFICIAL DOES NOT IMPLY THAT TDAS S/C TECHNOLOGY R&D WILL ELIMINATE THE NEED FOR TDAS USER S/C R&D OR VICE VERSA — BOTH R&D'S MUST BE CONDUCTED
- TDAS USER SHOULD NOT BE FORGOTTEN, TDAS USER S/C R&D MUST BE DONE IN PARALLEL
- TDAS USER S/C R&D WILL CONTINUE EVEN AFTER TDAS S/C IS OPERATIONAL



STANFORD  
TELECOMMUNICATIONS INC.