

NASA Technical Memorandum 83582

The Infinite Line Pressure Probe

David R. Englund
Lewis Research Center
Cleveland, Ohio

and

W. Bruce Richards
Oberlin College
Oberlin, Ohio

Prepared for the
Thirty-ninth International Instrumentation Symposium
sponsored by the Instrument Society of America
Denver, Colorado, May 7-10, 1984

NASA

THE INFINITE LINE PRESSURE PROBE

David R. Englund
National Aeronautics and Space Administration
Lewis Research Center
21000 Brookpark Road
Cleveland, Ohio 44135

W. Bruce Richards
Physics Department
Oberlin College
Oberlin, Ohio 44074

E-1973

ABSTRACT

The infinite line pressure probe provides a means for measuring high frequency fluctuating pressures in difficult environments. A properly designed infinite line probe does not resonate; thus its frequency response is not limited by acoustic resonance in the probe tubing, as in conventional probes. This paper will review the characteristics of infinite line pressure probes and describe some applications in turbine engine research. A probe with a flat-oval cross section, permitting a constant-impedance pressure transducer installation, is described. Techniques for predicting the frequency response of probes with both circular and flat-oval cross sections are also cited.

INTRODUCTION

Measurement of fluctuating pressure is a common requirement in aerospace research. To make such measurements, transducers are often connected to the desired points of measurement with short lengths of tubing. In these cases the frequency response of the measuring system is often limited by acoustic resonance of the connecting tube and transducer cavity volume. The direct approach to increasing the frequency response of the measuring system is to decrease the length of the connecting tube and minimize the transducer cavity volume. When this approach has been taken to the limits imposed by environment or geometry, and the frequency response is still unacceptable, the infinite line pressure probe may be the answer.

The ideal infinite line pressure probe is a non-resonant system. It consists of a long tube which acts as a waveguide for pressure fluctuations; the tube must be long enough so that the pressure fluctuations are sufficiently dissipated before reaching the end of the tube that reflections do not result. A pressure transducer set into the wall of the tube senses the pressure fluctuations passing down the tube and provides the desired pressure related signal. To avoid resonance, the ideal infinite line must be designed so that no reflections of pressure waves occur anywhere within the line. This means that the acoustic impedance, the product of gas density and velocity of sound divided by cross section area, must be constant. Achieving absolutely constant acoustic

impedance is probably impossible, but approaching this goal means that care must be taken to minimize cross sectional area changes, especially at the tap for the pressure transducer. Care must also be taken to avoid gross changes in gas properties.

There are relatively few descriptions of infinite line pressure probes in the technical literature. The earliest work known to these authors was done at NACA's Lewis Flight Propulsion Laboratory (now the NASA Lewis Research Center) in the early 1950's and is described in reference 1. In this work a water-cooled infinite line probe was used to study combustion instabilities in afterburners. Reference 2 describes the application of infinite line probes to measure fluctuating chamber pressure in the nuclear rocket (NERVA) program in the 1960's. Reference 2 is a primary source for information on infinite line probes; it provides an extensive description of the infinite line technique, describes methods for predicting the response, and shows the effect of variation of design parameters. Reference 3 describes some applications of infinite line probes in turbine engine testing. Reference 4 describes a more recent application in which an infinite line probe was used to measure acoustic noise in the burner of a YF-102 turbine engine. Figure 1 shows the probes from references 1 and 4. There is remarkable similarity in these probes even though some 20 years and many advances in instrumentation separate their development.

Many applications for infinite line probes in turbine engine testing (ref. 3) can take advantage of the high natural frequencies and small size of sub-miniature silicon-diaphragm pressure transducers. These transducers have natural frequencies as high as 500 kHz and can be made as small as 1.2 mm in diameter. These advantages make it feasible to build infinite line probes with frequency response approaching 100 kHz. Such a probe has been developed and put into limited use at the Lewis Research Center. The probe uses tubing with a flat-oval rather than circular cross section in order to permit the pressure transducer diaphragm to be mounted flush with the inside wall of the tubing.

The intent of this paper is to describe the infinite line probe and its characteristics in general,

and then to describe in more detail the flat-oval infinite line probe. Methods for calculating frequency response and phase shift of probes with both circular and noncircular cross sections will be cited.

CHARACTERISTICS OF AN INFINITE LINE PROBE

Before discussing the performance characteristics of an infinite line probe, it will be necessary to describe the geometry of the probe and define the parameters of interest. Figure 2 shows a schematic diagram of an infinite line probe and lists the parameters. The pressure to be measured, $P_0(t)$, excites a pressure fluctuation in the probe at the measurement end and this disturbance propagates down the line. The pressure measured by the pressure transducer, $P_x(t)$, is the pressure wave after it has traveled the distance x down the line. After passing the transducer the pressure wave continues to the termination. For a line of finite length there must be a termination and this will cause a reflection; for a properly designed line this reflected wave will be weak enough to be negligible when it arrives back at the transducer. The termination is arbitrary from the standpoint of the line design: it may be open to the atmosphere, open into a volume, or may be closed. The choice of termination depends upon safety, environmental, and practical considerations related to the experiment on which the line is used. In some cases it may be desirable to introduce a small, steady flow of gas at the termination of the line which will act to purge the line of gas from the experiment. This technique is especially useful to keep reacting gases out of the line and was used in the work of references 1 and 4.

If the pressure at the inlet is given by $P_0 \cos \omega t$, then the pressure wave traveling down the line can be described as

$$P_x(t) = P_0 e^{-ax} \cos(\omega t - bx)$$

where

$P_x(t)$ = pressure at any point x in the line at time t

a = attenuation factor

b = phase factor

ω = circular frequency

The attenuation factor is a function of the line diameter, the gas properties, and the frequency. The phase factor defines the phase lag resulting from propagation of the wave down the line at phase velocity.

It is important that there is nothing to cause a reflection of the pressure wave as it passes down the line (i.e., the line must have constant acoustic impedance). In general this means that the cross section area of the line be constant throughout and that there be no changes in gas properties (e.g., a temperature gradient) within the line.

In real probes this means no crimps or burrs at places where tubing sections are joined, no sharp bends, no sharp changes in tubing shape, and especially that the transducer tap volume be small or that the transducer be coupled to the line in such a way as to minimize a change in the impedance of the line. This may be accomplished with a short, small diameter passage (or a group of such passages) coupling the line to the transducer. However it must be recognized that this system of passages coupled with the transducer cavity is in itself an acoustic filter which will limit frequency response.

Analysis of Frequency Response

There have been numerous studies on the response of pressure tubing and pressure measuring systems. Of the many available, the analytical technique described in reference 5 has been found to be especially useful in analyzing infinite line probes. This technique can analyze series-connected systems of tubes and volumes. It allows one to calculate the sine wave pressure amplitude and phase angle in any volume in the system relative to the sine wave pressure amplitude at the input to the system. Thus it provides information in the standard amplitude ratio and phase angle versus frequency format.

For the conditions encountered in turbine engine testing, the frequency response predictions from this analysis are in good agreement with measured data. Comparisons of predicted and measured response are presented in references 5 and 6. The analytical technique of reference 5 was used in the work of reference 2.

The assumptions upon which the reference 5 analysis is based are the following:

1. No steady flow in the line.
2. The magnitudes of the pressure, density, and temperature fluctuations with time are small compared to time-averaged values. (When fluctuations are not small, wave shape distortion and amplitude-dependent attenuation can result. Reference 1 discusses these effects.)
3. The diameter of the line is small compared to the length.
4. The diameter of the line is small compared to acoustic wavelengths of interest.
5. Flow is laminar throughout the system.

Effect of Parameter Variation

Figures 3 to 9 have been prepared to illustrate the calculated performance of an infinite line probe and the effects of variations in parameters. These figures are similar to those presented in reference 2 except that the gas conditions and probe sizes are more representative of turbine engine testing than are the NERVA conditions (gaseous hydrogen at 37 atmospheres and temperatures of 100 to 300 K).

Figure 3 shows the performance of a baseline probe. The probe is a 2 mm inside diameter tube 2 meters long and closed at the end. A transducer is placed 4 cm from the entrance with a transducer tap volume of 0.45 mm^3 . The gas conditions are those of air at 1 atmosphere and 300 K. The probe performance is plotted as amplitude ratio P_g/P_0 and phase shift versus frequency. The amplitude ratio scale is expanded so as to show the effects of reflections. The amplitude ratio is 1.00 at low frequency and is only slightly attenuated to 0.90 at 10 kHz. The oscillation in the amplitude ratio at low frequencies is due to reflections from the end of the line. The amplitude ratio oscillations above 5 kHz are due to pressure waves reflecting between the tap volume and the measurement end of the line. The phase shift increases smoothly and becomes large at frequencies at which the tap length represents multiple wavelengths.

Figure 4 illustrates the effects on amplitude ratio of changing probe design parameters. Figure 4(a) illustrates the effect of increasing the line diameter from 2 to 2.5 mm. With the larger diameter there is less attenuation of pressure amplitude and the amplitude ratio oscillation due to reflections from the end of the line is larger. The oscillation due to reflections from the tap volume is about the same because it is affected by two opposing factors: there is less attenuation because of the increased diameter, but the relative discontinuity at the tap volume is smaller, causing a weaker reflection.

Figure 4(b) shows the effect of increasing the length of the line from 2 to 4 m. The oscillation due to reflection from the end of the line is reduced; the oscillation due to reflection from the tap volume is unchanged.

Figure 4(c) shows the effect of reducing the tap length from 4 to 3 cm. The magnitude of the oscillation due to reflection from the end of the line is reduced somewhat because the pressure tap is closer to the pressure node which must exist at the open end of the probe. However, the major effect is that the oscillation due to reflection from the tap volume shifts to a higher frequency band.

In figure 4(d) the tap volume is changed from 0.45 to 1.35 mm^3 and to zero. There is no change in the oscillation due to reflections from the end of the line. However, changes in tap volume alter the strength of the reflection from the tap volume thus affecting the magnitude of the oscillation in amplitude ratio at high frequencies. With zero tap volume there is no reflection and the oscillation in amplitude ratio in the higher frequency band vanishes.

The effects of changes in gas properties are illustrated in figure 5. Figure 5(a) shows the effect of increasing the average pressure level from 1 to 1.5 atmospheres. The increased pressure results in a lower kinematic viscosity (μ/ρ) and the attenuation in the line is reduced. Thus the magnitudes of the oscillations due to reflec-

tions from both the end of the line and the tap volume are greater.

The last of the baseline illustrations, figure 5(b), shows the effect of temperature gradients along a probe. Case A shows the effect of a 500 K linear gradient over a length span from $X = 0.5$ to $X = 3.5$ cm. Case B shows what happens if that 500 K gradient exists within the first cm of the probe length. The response for case A shows that temperature gradients of this kind are undesirable (note the change in scale of amplitude ratio on this figure). However, the case B result shows that by forcing the gradient to the very front end of the probe, the effect of the gradient can be pushed to a high frequency band, possibly out of the frequency range of interest. Positioning of the temperature gradient may be accomplished by a combination of water cooling and a slight purge gas flow down the line.

THE INFINITE LINE PROBE WITH FLAT-OVAL TUBING

Design Details

The objective in developing the flat-over probe was to get the highest possible frequency response in a configuration compatible with turbine engine testing. The natural frequency of a silicon-diaphragm pressure transducer with 1.2 mm diameter and a 1.6 atmosphere pressure range is approximately 500 kHz, and the flat (within 5 percent) frequency response limit is approximately 100 kHz. The task was to design an infinite line probe to use such a transducer and not limit the inherent response of the transducer.

There are two size limitations imposed on the design. One is that the internal dimensions of the line must be small compared to the free space wavelength for the maximum frequency of interest (roughly 3.4 mm for 100 kHz in room temperature air). The other limit arises from the anticipated application, which was to make total pressure measurements in compressor blade wakes. For this application a probe configured to measure total pressure would be mounted radially behind a compressor rotor. Optimum resolution of the blade wake required that the probe opening be small (less than 1 mm) in the blade passing direction.

A probe design based on tubing with a flat-oval cross section seemed best suited to meet these requirements. This cross section would provide reasonable area while maintaining a small dimension in the blade passing direction and provide a flat surface so that the pressure transducer can be installed with minimal tap volume. The measuring end of the resulting probe is shown in figure 6. The inside dimensions of the flat-oval cross section are 2.5 by 0.8 mm. The head of the probe was made from two rectangular plates which were electric-discharge-machined (EDM'd) to give the correct passage shape when the two pieces were mated together. The EDM'd passage has a gradual 90° bend (centerline radius of curvature is 2.7 mm) so as to make the probe opening normal to the axis of the probe body (i.e., to allow measurement of total pressure). The remainder of the infinite

line is made from flat-oval stainless steel tubing supported within 1/4 inch diameter tubing which forms the body of the probe. This tubing was carefully mated to the EDM'd passage in the probe head so as to avoid discontinuities in the inside surface of the line. The total length of the line is 63.5 cm; this length was determined assuming use of the probe in air at 1 atmosphere pressure. The probe head was carefully shaped with a file to achieve the shape shown in figure 6 after the probe was assembled. The back side of the transducer can be seen in figure 6 as the dark object on the side of the probe head. The dark material is epoxy covering the transducer lead wires.

The pressure transducer is a flat configuration with the diaphragm at the end of a short (0.3 mm) cylinder with its axis normal to the flat plate which forms the mounting surface of the transducer (see fig. 7). The transducer is mounted with silicone rubber to the outside of the probe head so that the cylinder holding the diaphragm protrudes through a hole in the probe head and positions the diaphragm flush with the inside surface of the flat oval passage. The distance from the center of the diaphragm to the probe opening (i.e., the tap length) is 1.2 mm. If the diaphragm is mounted perfectly flush with the inside surface of the passage, the tap volume is zero; with an uncertainty in diaphragm position of 0.05 mm, the maximum tap volume is 0.09 mm^3 .

Frequency Response

A major problem in developing probes for these very high acoustic frequencies is that measuring their frequency response ranges from difficult to impossible. In the case of this probe, no attempt was made to measure frequency response. Instead, reliance was placed upon analytical predictions of frequency response. The difficulty with this approach is that the analysis of reference 5 requires a circular cross section.

A study was undertaken to find a solution that could be used for the flat-oval cross section (ref. 7). Early in this study it was determined that a solution comparable to that in reference 5 could not be obtained for tubes of noncircular geometry; however, a solution for plane waves traveling between infinite flat plates was possible. This flat plate solution suggested that, for the probe sizes under consideration, the frequency response of the flat-oval tubing would be nearly identical to that of an equivalent circular tube with a diameter given by four times the area of the flat-oval cross section divided by its perimeter. The reference 5 analysis for circular tubing using this equivalent diameter could therefore be used to predict the frequency response of flat-oval probes. Note, however, that the actual cross section area must be used at places in the equations where the area and velocity are used to compute the volume flow rate. For the flat-oval section used in this work, the equivalent diameter is 1.20 mm. This equivalent diameter concept is quite similar to the well-known "hydraulic diameter" used to characterize liquid flow in open channels. The study presented in reference 7 in-

cludes a comparison of predicted and measured frequency response data. Three different tube-and-volume systems were tested in which the tubes were lengths of the flat-oval tubing used to make the infinite line probe. The experimental results agreed closely with the predictions.

Reference 7 also presents an approach to calculating the response of tube-and-volume systems which may be preferable to the reference 5 approach for some users. The reference 5 method uses a recursion equation by which the pressure amplitude and phase angle in one volume may be determined relative to other volumes in a series-connected string of tubes and volumes. The alternate approach of reference 7 uses a product of matrices similar to the ABCD matrices used in solutions of electrical transmission line problems.

Figure 8 presents the calculated frequency response of the flat-oval infinite line probe described in this report. The probe parameters and gas conditions used for the calculation are listed in the figure. With the short tap length (1.2 mm) the attenuation is very low, even at high frequencies. The calculated results are shown for two values of tap volume: zero and 0.09 mm^3 . It is quite apparent that minimizing the tap volume in the mounting of the transducer is important.

Test Experience

Although the flat-oval infinite line probe was intended for measurements in blade wakes, its major use to date has been in an aeroelastic fan flutter experiment. In this experiment the objective was to measure the dynamic pressure field upstream of the fan during flutter and nonflutter operating conditions. The probe was mounted upstream of the fan of an F-100 turbine engine and was positioned 180 degrees from the flow direction so as to point downstream toward the fan. The engine had additional instrumentation to detect and measure the effects of flutter. This included a photoelectric scanning system to detect nonengine order vibration of the blade tips, dynamic strain gages on the fan blades, and miniature pressure transducers in the fan casing over the tips of the fan blades.

An example of the pressure data obtained from the probe is shown in figure 9. Figure 9(a) is the fluctuating static pressure versus time; the predominant frequency in this signal is the fan blade passing frequency, 4631 blades per second. The higher frequency portions of this signal are part of the repetitive structure of the pressure field. Figure 9(b) shows the frequency spectrum of this signal. The predominant peak is the blade passing frequency at 4631 Hz, and harmonics out to the seventh are apparent.

Another test using the flat-oval infinite line probe is reported in reference 8. In this test the response of the infinite line probe was compared with that of a frequency compensated drag force anemometer. The compensated frequency response of the anemometer was calculated to be flat well beyond the fundamental natural frequency (42.8 kHz) of the anemometer beam. The comparison

was made by using each instrument to measure the profile of shock waves exiting a small shock tube. Figure 10 shows that the two waveforms are nearly identical.

CONCLUDING REMARKS

This paper has discussed the infinite line pressure probe and its potential for fluctuating pressure measurements in turbine engines. Some examples of applications of infinite line probes in turbine engine testing were given. The general operating characteristics and design parameters of the infinite line probe were described. Methods for analyzing the frequency response of infinite line probes were cited. Finally, a specific probe designed for very high frequency response was described.

In the discussion of the general operating characteristics of the infinite line probe, the calculated response of a baseline probe design was presented. Then the effects of changes in probe design parameters were illustrated in a series of frequency response diagrams. This part of the discussion is very similar to the presentation made by Samuelson (ref. 2) in 1967. It must be acknowledged that Samuelson presented a very complete and definitive treatise on the infinite line probe. However, the examples presented in reference 2 were for nuclear rocket applications and are not easily related to turbine engine test conditions. The discussion presented here was intended to provide illustrations for these somewhat different conditions.

Finally, application of this information to specific measurement problems should be considered. The design of infinite line probes is complicated by the lack of approximation equations comparable to the linearized second order system equations used to describe the response of simple tube-and-volume pressure measuring systems. For this reason reliance on the computer-based analysis procedures cited herein is almost mandatory. Once these analysis procedures are made operational, however, the advantages afforded by their use are considerable. The frequency response of a great variety of configurations can easily be calculated, including, if necessary, noncircular cross

sections. In addition, the accuracy of these analyses should be sufficient to minimize or, in some cases, eliminate experimental determination of the frequency response of pressure measuring probes.

REFERENCES

1. Blackshear, P. L.; Rayle, W. D.; and Tower, L. K.: Study of Screeching Combustion in a 6-Inch Simulated Afterburner. NACA TN 3567, 1955.
2. Samuelson, R. D.: Pneumatic Instrumentation Lines and Their Use in Measuring Rocket Nozzle Pressure. Report No. RN-DR-0124, Nuclear Rocket Operations, Aerojet-General Corporation, 1967.
3. Fischer, J. E.: Fluctuating Pressure Measurements from DC to Over 100 kHz in Jet Engine Testing. Instrumentation in the Aerospace Industry, Vol. 17, Instrument Society of America, 1971, pp. 117-123.
4. Reshotko, M.; Karchmer, A. M.; Penko, P. F.; and McArdle, J. G.: Core Noise Measurements on a YF-102 Turbofan Engine. American Institute of Aeronautics and Astronautics, AIAA 77-21, 1977.
5. Bergh, H.; Tijdeman, H.: Theoretical and Experimental Results for the Dynamic Response of Pressure Measuring Systems. Rep. NRL-TR-F.238, National Aero- and Astronautical Research Inst., Amsterdam, 1965.
6. Nyland, T. W.; Englund, D. R.; and Anderson, R. C.: On the Dynamics of Short Pressure Probes: Some Design Factors Affecting Frequency Response. NASA TN D-6151, 1971.
7. Richards, W. B.: On the Propagation of Sound Waves in Tubes of Non-Circular Cross Section. NASA TM to be Published.
8. Fralick, G. C.: Extending the Frequency of Response of Lightly Damped Second Order Systems: Application to the Drag Force Anemometer. NASA TM 82927, 1982.

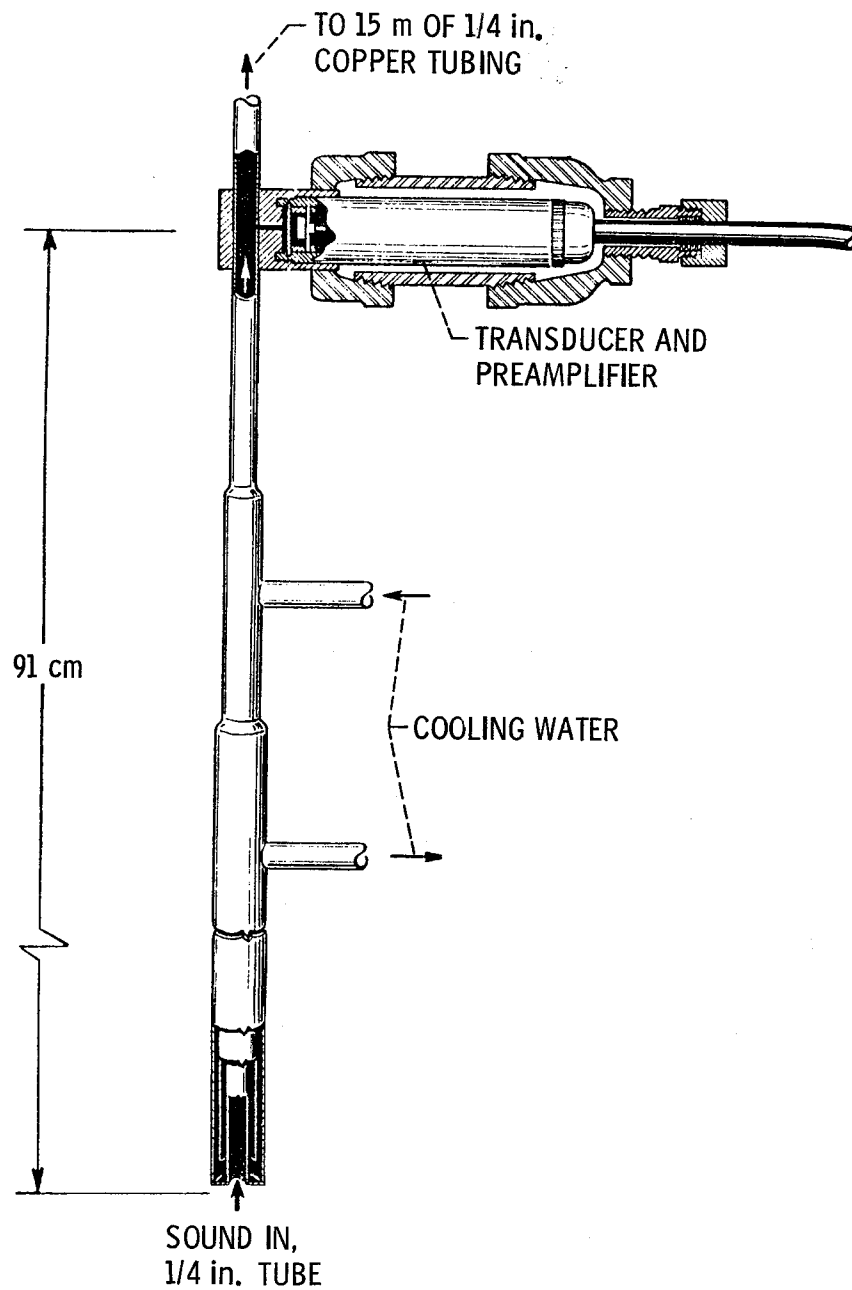

(a) Reference 1 probe.

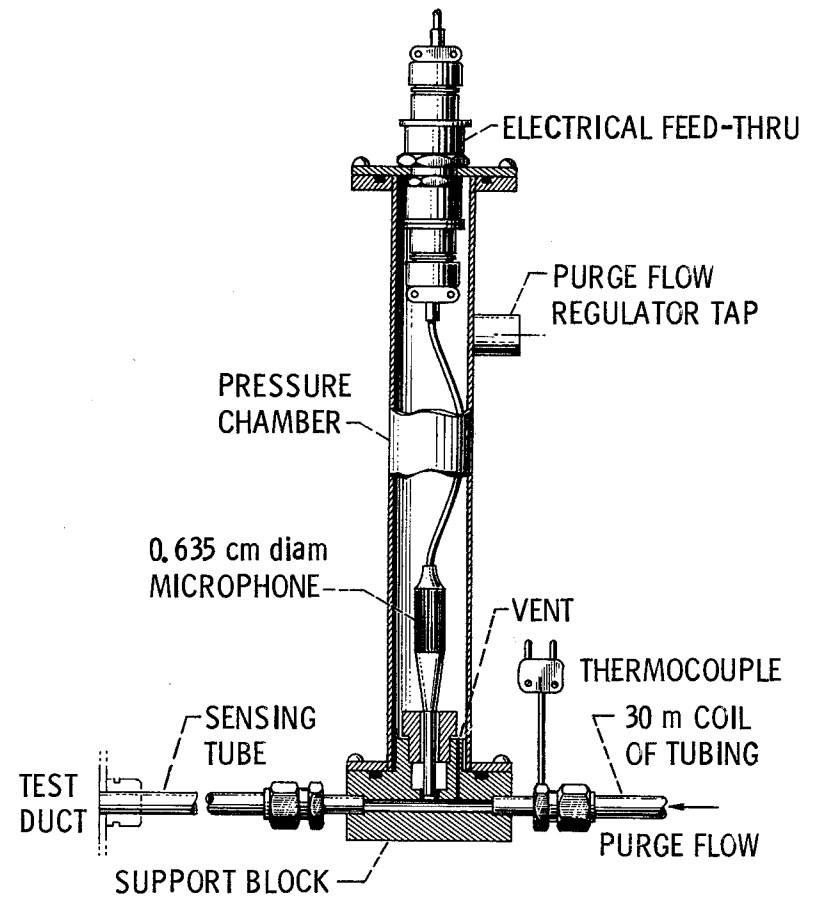

(b) Reference 4 probe.

Figure 1. Infinite line probes used in afterburner and combustor testing.

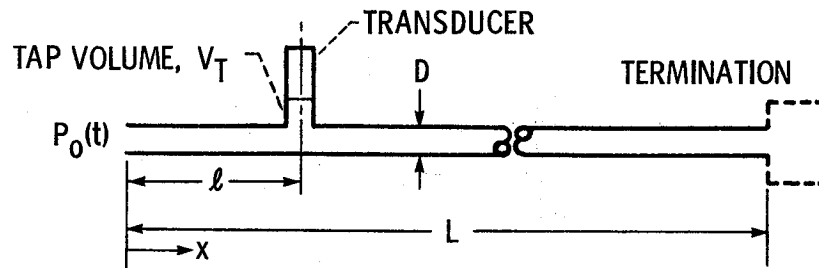

D \equiv INSIDE DIAMETER OF LINE

L \equiv TOTAL LENGTH OF LINE

l \equiv TAP LENGTH, LENGTH FROM MEASUREMENT END OF LINE TO TRANSDUCER

V_T \equiv TAP VOLUME, VOLUME AT TRANSDUCER/LINE INTERFACE

GAS PROPERTIES OF INTEREST

$P_0(t)$ - FLUCTUATING PRESSURE AT MEASUREMENT END OF LINE

$P_x(t)$ - FLUCTUATING PRESSURE AT POINT x IN LINE

$P_l(t)$ - FLUCTUATING PRESSURE AT TRANSDUCER

T - GAS TEMPERATURE

ρ - GAS DENSITY

γ - RATIO OF SPECIFIC HEATS C_p/C_v

μ - GAS VISCOSITY

C - SONIC VELOCITY, $\gamma P/\rho$

ν - KINEMATIC VISCOSITY, μ/ρ

Figure 2. Schematic diagram of infinite line with definition of parameters of interest.

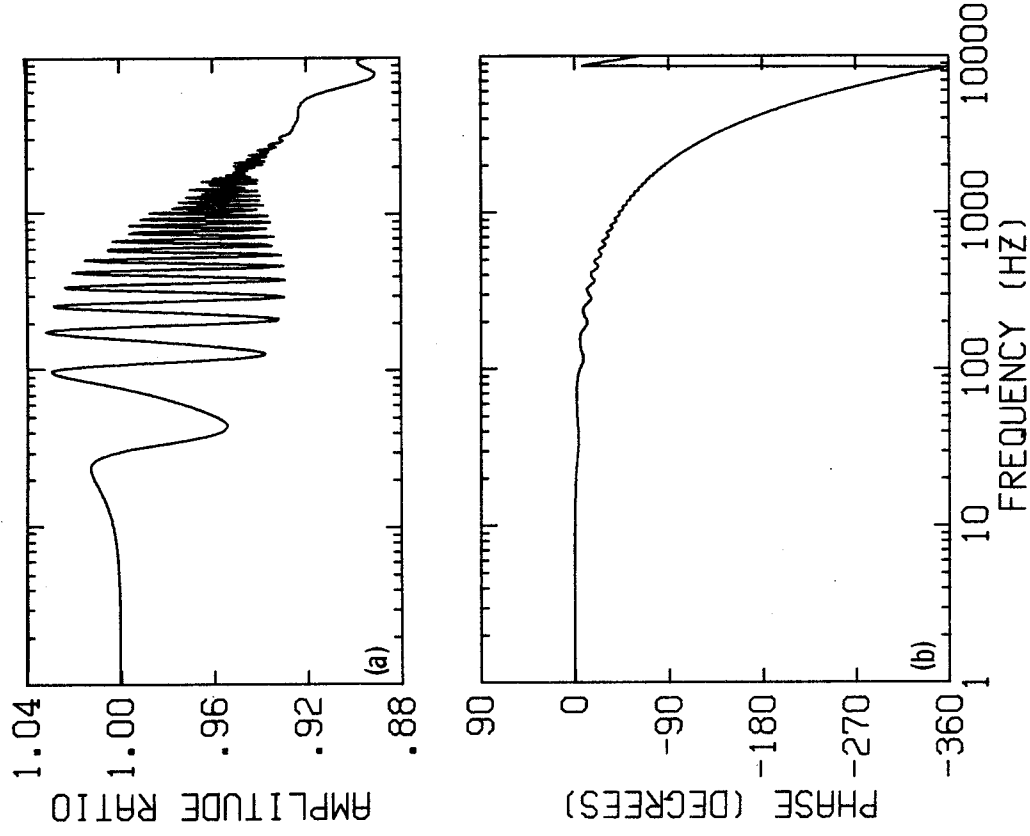

Figure 3. Frequency response of baseline infinite line probe. $D = 2$ mm, $L = 2$ m, $\ell = 4$ cm, $V_T = 0.45$ mm³; air at 1 atm and 300 K.

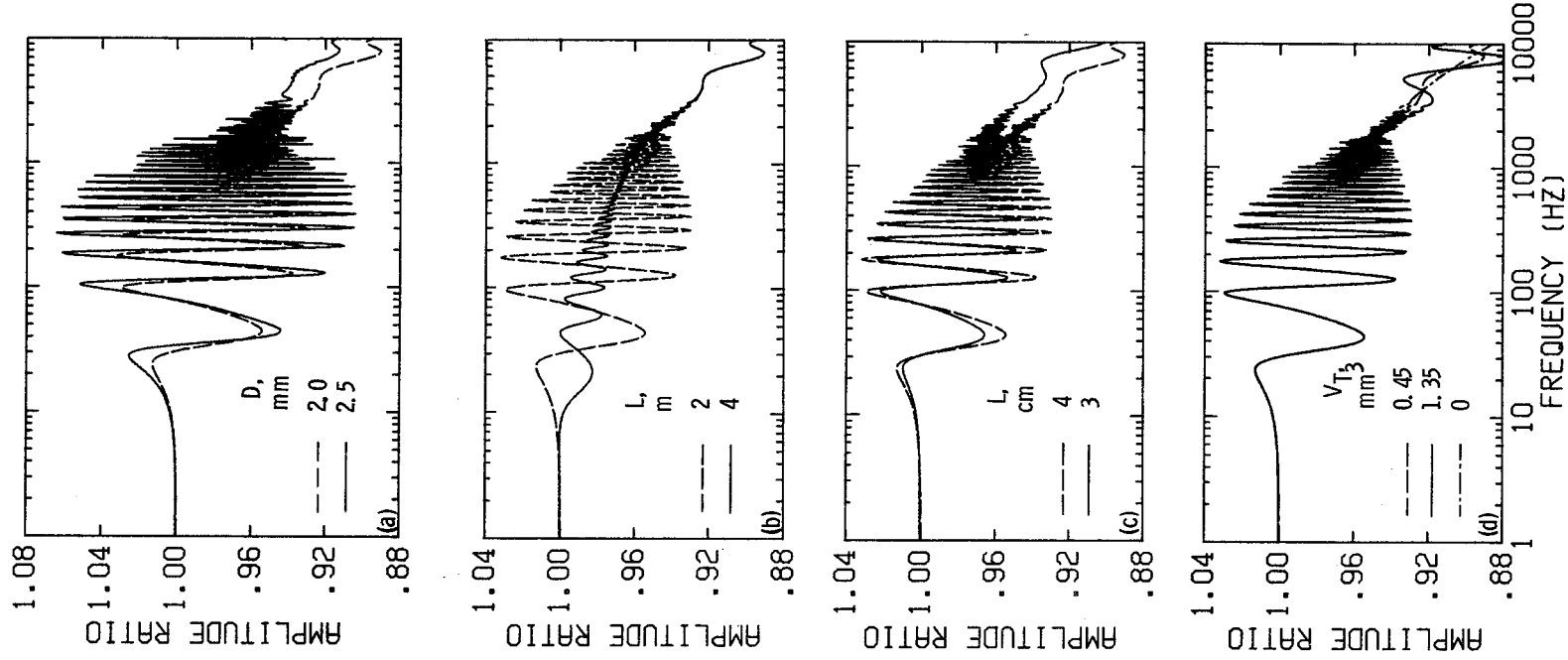
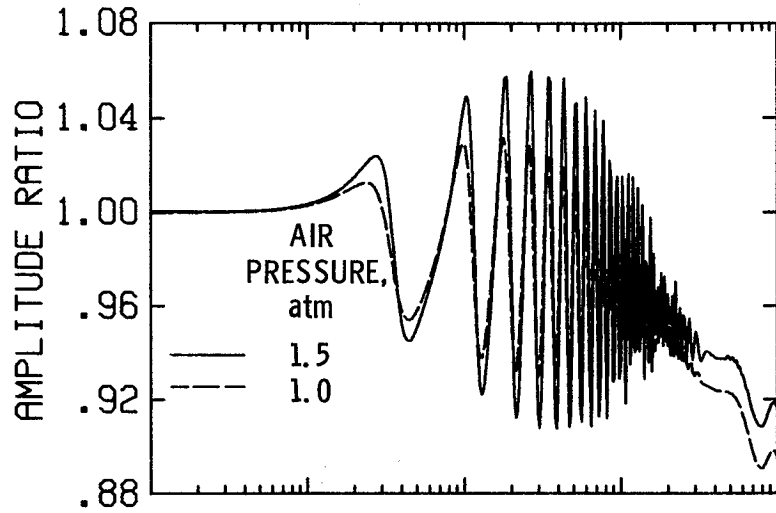
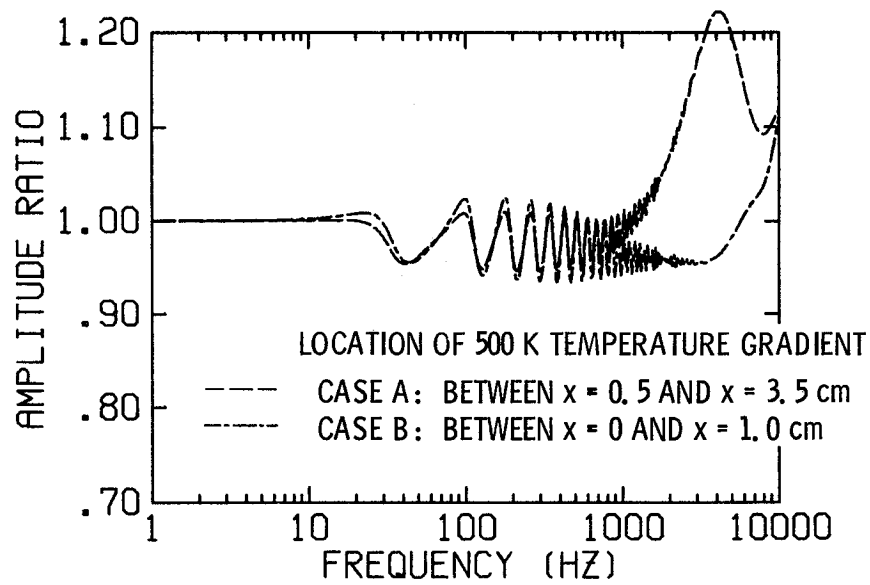

Figure 4. Effects on frequency response of changes in probe design parameters. Baseline conditions: D , 2 mm; L , 2 m; l , 4 cm; V_T , 0.45 mm³; air at 1 atm and 300 K.



(a) Average pressure.



(b) Temperature gradient.

Figure 5. Effects on frequency response of changes in gas properties. Baseline conditions: D , 2 mm; L , 2 m; l , 4 cm; V_T , 0.45 mm³; air at 1 atm and 300 K.

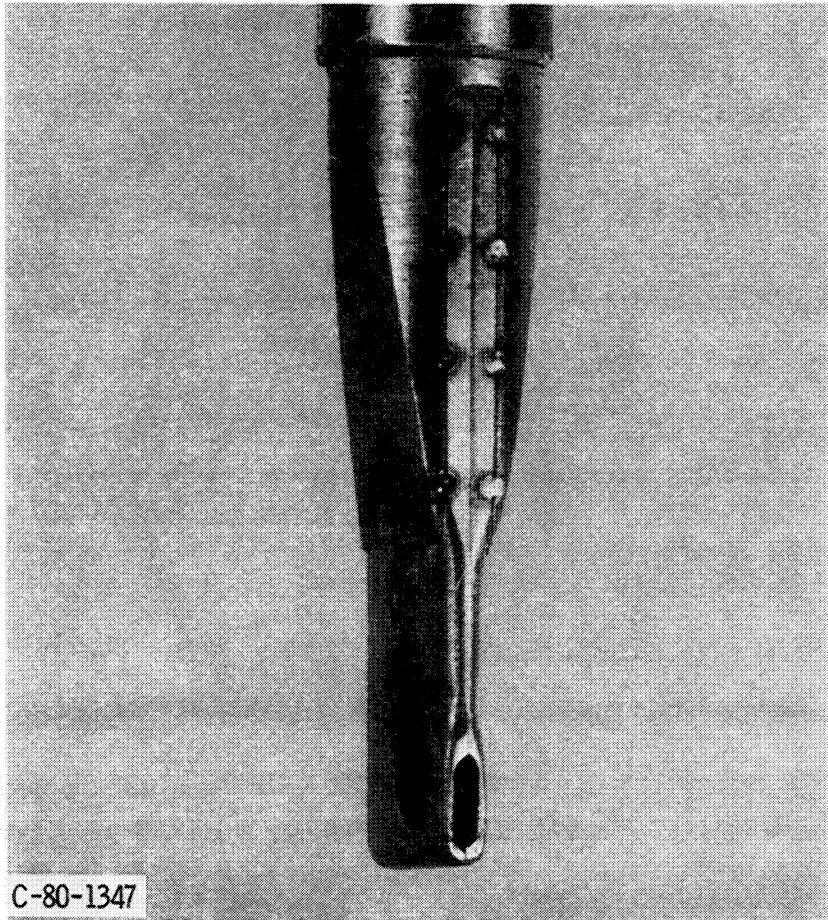

Figure 6. - Measuring end of flat - oval infinite line probe.

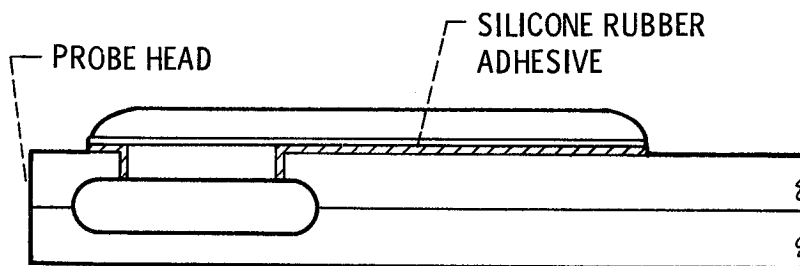
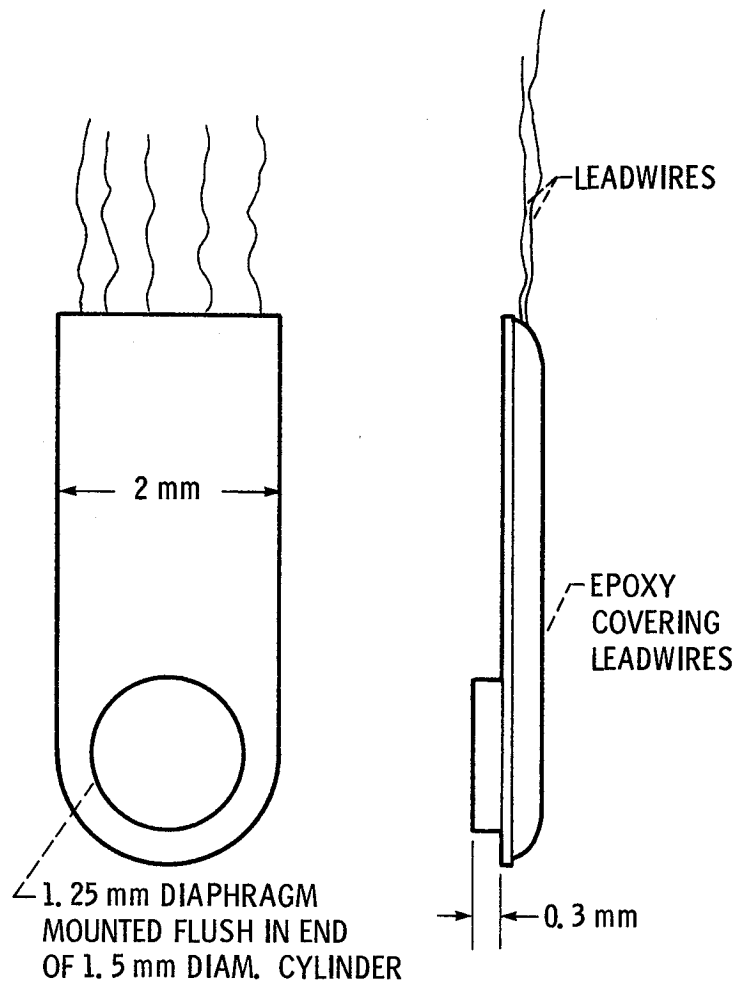

Figure 7. Pressure transducer configuration and transducer mounting in flat-oval probe.

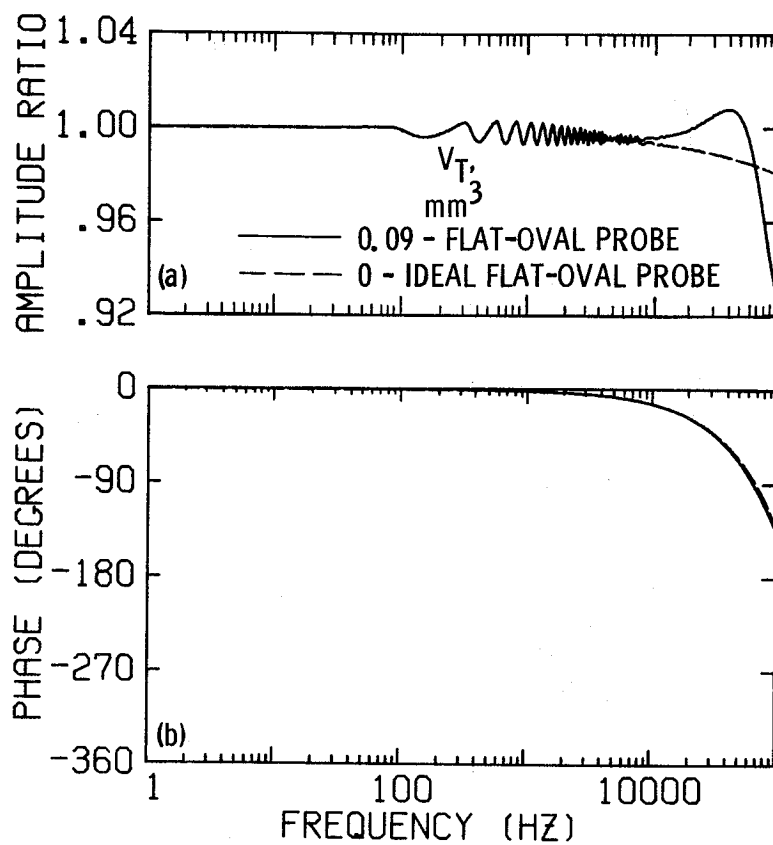

Figure 8. Calculated frequency response of flat-oval infinite line probe. Probe parameters: equivalent D , 1.20 mm; L , 0.63 m; l , 1.2 mm; air at 1 atm and 300 K.

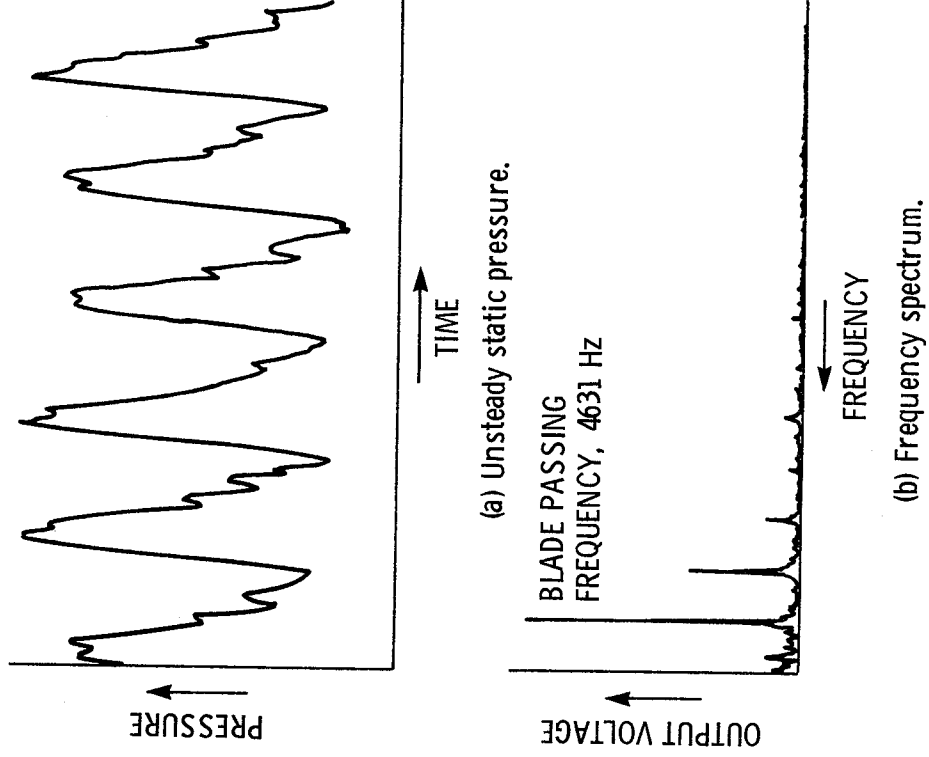
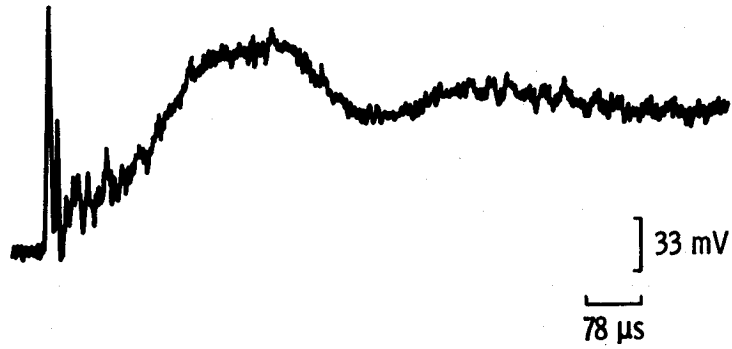
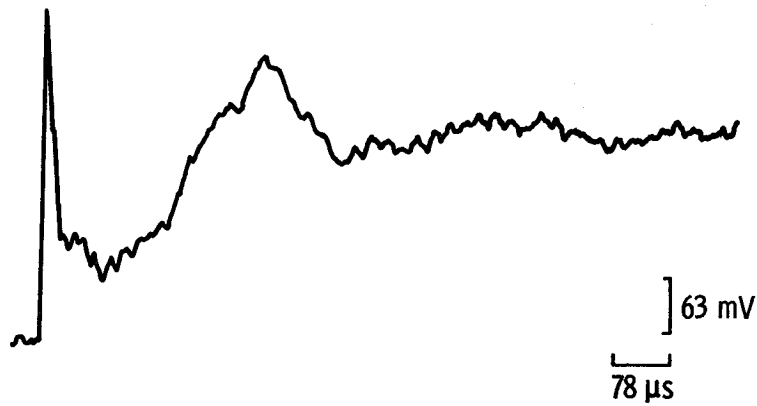

Figure 9. Infinite line probe measurements taken upstream of fan rotor in turbofan engine.



(a) Transient response of compensated drag force anemometer to shock wave.



(b) Transient response of flat-oval infinite line probe to shock wave.

Figure 10. Comparison of transient response of flat-oval infinite line probe and compensated drag force anemometer to shock wave.

1. Report No. NASA TM-83582		2. Government Accession No.		3. Recipient's Catalog No.	
4. Title and Subtitle The Infinite Line Pressure Probe				5. Report Date	
				6. Performing Organization Code 505-40-1B	
7. Author(s) David R. Englund and W. Bruce Richards				8. Performing Organization Report No. E-1973	
				10. Work Unit No.	
9. Performing Organization Name and Address National Aeronautics and Space Administration Lewis Research Center Cleveland, Ohio 44135				11. Contract or Grant No.	
				13. Type of Report and Period Covered Technical Memorandum	
12. Sponsoring Agency Name and Address National Aeronautics and Space Administration Washington, D. C. 20546				14. Sponsoring Agency Code	
15. Supplementary Notes David R. Englund, Lewis Research Center; W. Bruce Richards, Oberlin College, Physics Dept., Oberlin, Ohio 44074. Prepared for the Thirtieth International Instrumentation Symposium sponsored by the Instrument Society of America, Denver, Colorado, May 7-10, 1984.					
16. Abstract The infinite line pressure probe provides a means for measuring high frequency fluctuating pressures in difficult environments. A properly designed infinite line probe does not resonate; thus its frequency response is not limited by acoustic resonance in the probe tubing, as in conventional probes. This paper will review the characteristics of infinite line pressure probes and describe some applications in turbine engine research. A probe with a flat-oval cross section, permitting a constant-impedance pressure transducer installation, is described. Techniques for predicting the frequency response of probes with both circular and flat-oval cross sections are also cited.					
17. Key Words (Suggested by Author(s)) Pressure measurement Dynamic pressure			18. Distribution Statement Unclassified - unlimited STAR Category 35		
19. Security Classif. (of this report) Unclassified		20. Security Classif. (of this page) Unclassified		21. No. of pages	22. Price*