

NASA Technical Memorandum 86039

NASA-TM-86039 19840012447

---

# A Review of Recent Developments in Flight Test Techniques at the Ames Research Center, Dryden Flight Research Facility

---

Garrison P. Layton

---

April 1984

LIBRARY COPY

APR 10 1984



**NASA**  
National Aeronautics and  
Space Administration

---

# A Review of Recent Developments in Flight Test Techniques at the Ames Research Center, Dryden Flight Research Facility

---

Garrison P. Layton  
NASA Ames Research Center, Dryden Flight Research Facility, Edwards, California 93523

1984



National Aeronautics and  
Space Administration

**Ames Research Center**

Dryden Flight Research Facility  
Edwards, California 93523

*N84-20515 #*

A Review of Recent Developments in Flight Test Techniques at the  
Ames Research Center, Dryden Flight Research Facility

Garrison P. Layton  
NASA Ames Research Center  
Dryden Flight Research Facility  
Edwards, California

INTRODUCTION

This paper reviews some of the flight test techniques currently being used or developed at NASA Ames Research Center's Dryden Flight Research Facility (fig. 1). Use of ground and airborne computational capability to increase flight test capability and to enhance data return, checkout of systems-driven aircraft, and new techniques for collecting basic data are discussed.

AIRBORNE AND GROUND COMPUTATION TRENDS

The advent of reliable computational capability and digital data links has created new opportunities and challenges for those in the flight test business (fig. 2). The following sections discuss some of the ways in which these capabilities are being used at Ames Dryden, ranging from remotely piloted research vehicles to vehicles with part of their control loops being closed through a data link with a ground-based computer.

Remotely Piloted Research Vehicles

The most extreme example of using ground facilities to control the flight vehicle is the remotely piloted research vehicle (RPRV, fig. 3). In this case, state information is downlinked to a pilot's display and a control system computer, which also receives pilot-commanded information. Control surface commands are then uplinked to the test aircraft. Figure 4 shows a typical control station, a cockpit similar in shape and function to a typical fixed-base simulator cockpit. In the system used at Ames Dryden, during normal flying the aircraft is "dumb"; that is, all control and guidance loops are controlled through the ground computer. Control loops are closed onboard for the backup control modes in which the vehicle is controlled as a "drone," either from the ground or from a chase aircraft. RPRVs are used at Ames Dryden for testing considered too high in risk for manned testing. Such vehicles that have been or will be tested include the spin research vehicle; the drones for aerostructural testing (DAST) vehicle, an active flutter suppression experiment; and the controlled impact demonstration test to be performed with a Boeing 720 aircraft to test antimisting kerosene fuels (fig. 5). The data return from these programs to date has been good, and we have concluded that RPRVs are a good approach for high-risk testing.

RPRVs are also used in an attempt to reduce the cost and increase the timeliness of obtaining flight data on new technologies. The most complex vehicle flown to date, the highly maneuverable aircraft technology (HiMAT) vehicle (fig. 6), was built and flown with these as the primary objectives. The vehicle was flown 26 times, and the data are currently being evaluated to be presented at a symposium in May 1984.

The degree to which the original objectives were accomplished is also being evaluated.

### Remotely Augmented Vehicles

The combination of the F-8 digital fly-by-wire test bed, data links, and ground computation led to the concept of closing control loops in a ground computer to conduct basic handling qualities research (ref. 1) — the remotely augmented vehicle (RAV) concept (fig. 7). In this system, the single-strand uplink/downlink system is prevented from being flight critical by the basic redundancy management system of the F-8 test bed, thus allowing non-flight-critical software in a higher-order language to be used in the ground computer. This use of higher-order languages facilitates experimentation and separates the experiment from safety of flight. To avoid wasting flight time, the experimental software is still subjected to the verification and validation process.

### Remotely Computed Displays

The development of the uplink/downlink capability, coupled with the powerful ground computational capability, prompted the development of a new technique: the remotely computed display (RCD, ref. 2), shown in figure 8. In this system, aircraft state information received through telemetry is used in an algorithm in the ground-based computer to generate flight director commands that are sent back to the aircraft and displayed to the pilot.

Use of this technique enhances our ability to conduct flight tests in several ways. The technique allows the pilots to attain a steady-state test condition approximately 25 percent faster than with conventional techniques. Because instrument errors, position errors, and other biases are accounted for in the flight director algorithm, the points are flown more accurately than when using raw data presented on cockpit gages. Probably the most important use of this technique is in flying profiles that are difficult, or impossible, using standard methods. An example is shown in figure 9, a constant Reynolds number profile from Mach 0.6 to Mach 1.2. The technique has been used for a number of other demanding data profiles such as level windup turns, constant-radar-altitude decelerations, and zero-g profiles.

Currently, the flight director algorithms are generated using the experience of the pilots and experimenters, and trial and error on a simulator. Effort is underway to apply automated trajectory optimization techniques to the development of these algorithms.

### SYSTEMS-DRIVEN AIRCRAFT

The advent of systems-driven aircraft with extensive onboard computational capability has forced a revolution in the manner in which aircraft are checked out and deemed ready to fly on either the first mission or operational missions thereafter. This section describes how we have dealt with this revolution in two cases and how we plan to cope in the future.

## HiMAT Checkout and Simulation

When the HiMAT vehicle was first flown, it represented an extreme case of the problems encountered in testing a systems-driven aircraft with its redundant onboard computers, uplink, downlinks, and ground-based computations (ref. 3).

All the HiMAT flight software underwent two types of testing during the flight qualification process: verification testing and validation testing. Verification is the process by which it is determined whether the software performs exactly as specified. The verification process is accomplished by devising specific tests for each software task, conducting the test, and observing whether the task was accomplished according to specification. While verification testing used one or more of the computer systems from a HiMAT simulation, much of it was accomplished without simulating the dynamics of the vehicle. Validation is a broader task which seeks to determine whether the system, of which the software is a part, performs adequately to accomplish the flight requirements. Therefore, much of the validation testing requires simulation of the vehicle dynamics. This verification and validation process was conducted using the system shown in figure 10. Tests using this system varied: simple simulations used the computer facility to compute aircraft dynamics, and the cockpit; a complete simulation used the actual vehicle as an "iron bird," and simulation of the data links.

Additionally, the system of figure 10 was tied to the control room to drive the displays, charts, and maps to simulate the flight environment for the most critical element of the flight test system, the test team.

## F-8 Checkout and Simulation

The F-8 RAV was tested in a manner similar to that used for the HiMAT RPRV. A decommissioned airplane was used as an iron bird in combination with simulation hardware built specially for this program, as shown in figure 11. This system allowed verification and validation tests to be performed on the basic F-8 hardware and software, as well as on the special hardware and software associated with the RAV.

## Integrated Test Facility

To date, the systems used to check out our highly integrated vehicles have been built specifically for the needs of each program. This approach has resulted in considerable duplication of effort from program to program. To correct this deficiency, an integrated test facility (ITF) is being proposed (fig. 12) to meet the development test needs of the systems-driven aircraft that will be flight tested at Ames Dryden. This facility would incorporate features that would facilitate efficient operations and increase productivity. For example, the facility would house and integrate the current simulation/RPV and avionics laboratories. It would collocate all test and ground support equipment, would provide test bays for six to eight aircraft or iron birds, and would be large enough to accommodate an aircraft the approximate size of a B-52. The facility would be suitable for positive security control, and the test bays would be shielded where necessary. Integrated support equipment would be provided to allow interrogation and excitation of the various computer-based systems. Special equipment for handling inertial navigation systems and special optic sensors would be provided. The ability to apply dynamic control surface loading to simulate aerodynamic loads would be included, as would ground vibration test capability. A

data link to the aircraft engine runup area would be provided to allow closed-loop testing with the engine running.

## NEW TECHNIQUES

Work is constantly underway to develop new techniques to obtain and process data faster and more accurately, and to broaden the base of detailed aerodynamic data for use by future designers. The use of Kalman filter techniques for processing pitot-static position-error data and the use of a test fixture on the F-104 aircraft to obtain skin friction drag information are current examples of this kind of effort.

### Linearized Kalman Filter Techniques for Air Data Calibrations

From the earliest days of flight test, determination of air data from pitot-static information has been a difficult and time-consuming task. This task has traditionally been performed by quasi-steady-state comparisons of several data sources, such as balloon, radar, and tower flyby, to yield a position-error correction for the test aircraft's pitot-static system. A key ingredient of these methods was the experience of the experimenter in determining when during the test runs the various data sources were valid or not (fig. 13).

Current digital data handling methods allow the melding of data from many sources, thus simplifying the task somewhat. More importantly, the existence of all the data for a position-error correction in a single data base also allows modern digital analysis methods to be applied to the data.

A linearized Kalman filter (LKF) is being used to analyze data from the sources shown (fig. 14) to obtain position-error corrections, even in cases where one of the data sources is known to have problems. In the case of the HiMAT vehicle, a flight dedicated to airspeed calibrations resulted in the data shown in figure 15 because of a temperature sensitivity of the pitot-static pressure transducers. On later flights, the transducer problem was resolved, resulting in the correction shown on figure 16. The LKF trajectory reconstruction technique was applied to the original data, resulting in the correction shown, thus demonstrating that the technique can use data from multiple sources to discriminate pitot-static errors from instrumentation errors.

This method has also been successfully applied to space shuttle entry data (ref. 4). At a Mach number greater than 3.5, air data are obtained from inertial, body-axis rate and acceleration, and meteorological measurements. The LKF technique is used to blend these complementary sources of data to result in data with characteristics from all sources: high- and low-frequency content, data relative to fixed space, and data relating to the surrounding air mass. The high-frequency data relative to the surrounding air mass are essential for the extraction of high-confidence estimates of the stability and control characteristics.

### Aerodynamic Experiments

The aircraft at Ames Dryden are frequently used to carry detailed local-flow experiments into the flight environment. Typical of this approach is the flight test fixture (FTF) shown mounted on an F-104 aircraft (fig. 17). This fixture

features a well-documented smooth flow field, Mach number capability from 0.4 to 2.0, dynamic pressure to 90 kPa (1900 lb/ft<sup>2</sup>), and Reynolds number to  $23 \times 10^6$  per m ( $7 \times 10^6$  per ft) (ref. 5).

This fixture has been used to test new designs for pitot heads, to test the tiles used on the space shuttle, and to conduct studies of the effects of various devices to reduce base drag. Currently, large force balances (fig. 18) are being installed flush on the sides of the FTF. This will allow the direct measurement of skin friction and concurrent determination of skin friction from boundary layer measurement using existing rakes. Experiments will be conducted with excrescencies such as rivet heads, fasteners, and paint finishes on one side, while the other is maintained smooth as a control.

#### CONCLUDING REMARKS

NASA Ames Research Center's Dryden Flight Research Facility is continuing to develop new flight test techniques to expedite and enhance the collection and dissemination of flight test information. Remotely piloted research vehicles, remotely augmented vehicles, simulation of systems-driven aircraft, application of new computational techniques such as the linearized Kalman filter for air data calibrations, and use of the flight test fixture to conduct aerodynamic experiments in the flight environment are some of the techniques currently being used or developed at Ames Dryden.

#### REFERENCES

1. Larson, Richard R.; Smith, Rogers E.; and Krambeer, Keith D.: Flight-Test Results Using Nonlinear Control with the F-8C Digital Fly-By-Wire Aircraft. AIAA Paper 83-2174, Aug. 1983.
2. Meyer, Robert R., Jr.; and Schneider, Edward J.: Real-Time Pilot Guidance System for Improved Flight Test Maneuvers. AIAA Paper 83-2747, Nov. 1983.
3. Myers, Albert: Simulation Use in the Development and Validation of HiMAT Flight Software. Presented at AGARD 28th Guidance and Control Panel Symposium, Ottawa, Canada, May 1979.
4. Whitmore, Stephen A.: Reconstruction of the Shuttle Reentry Air Data Parameters Using a Linearized Kalman Filter. AIAA Paper 83-2097, Aug. 1983.
5. Meyer, Robert R., Jr.: A Unique Flight Test Facility: Description and Results. NASA TM-84900, 1982.



ECN 10170

Figure 1. NASA Ames Research Center's Dryden Flight Research Facility.

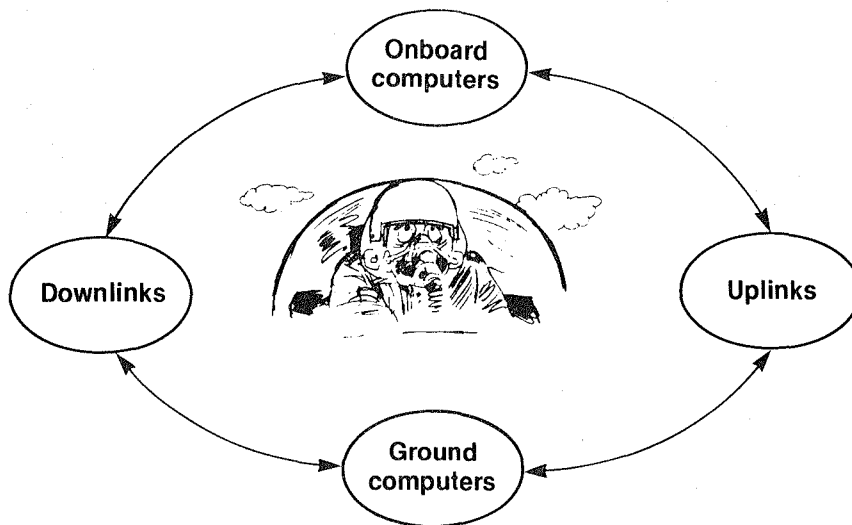

Figure 2. Control methods.



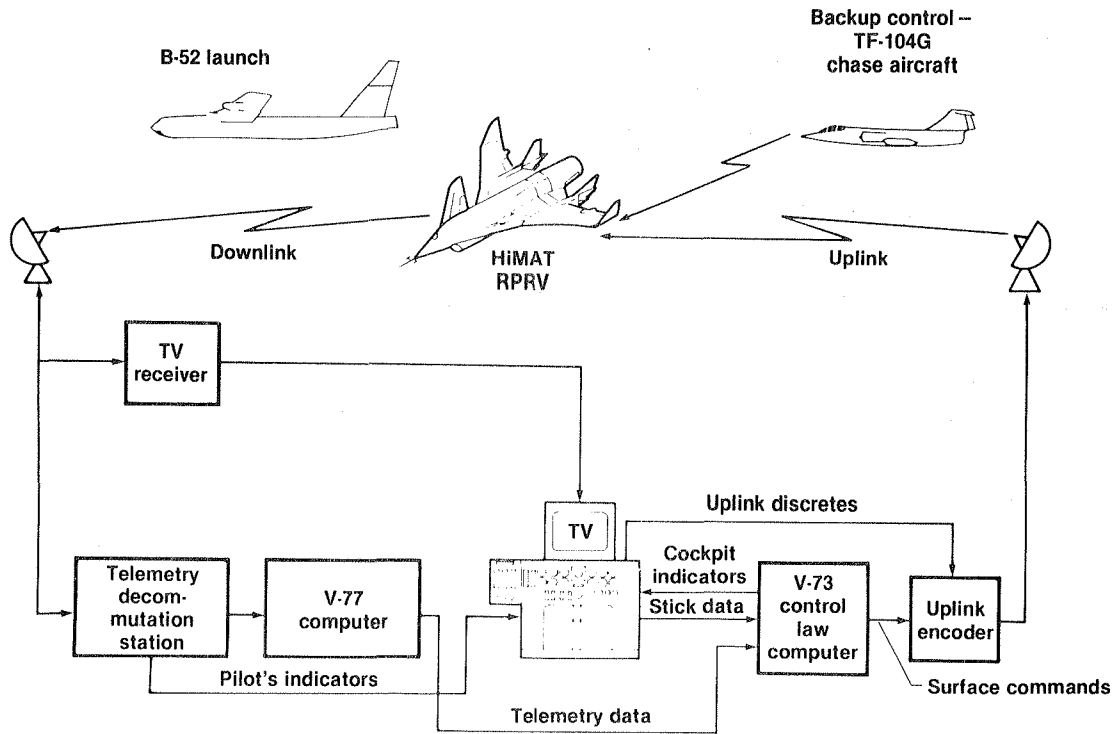
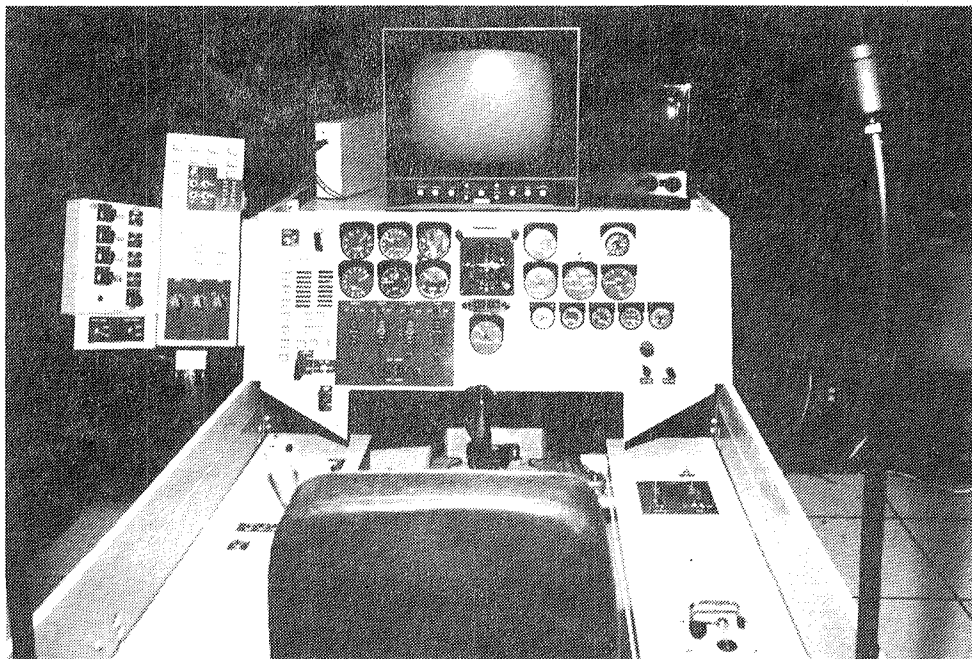
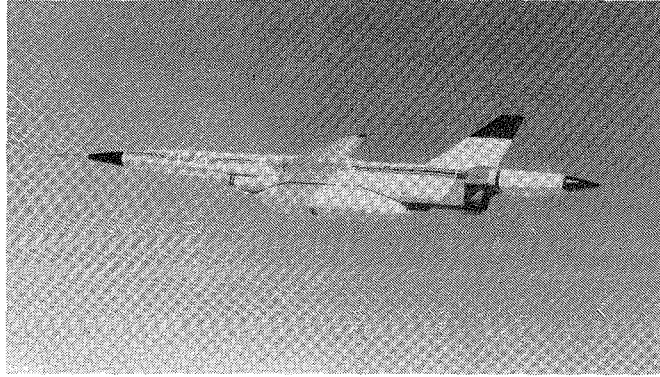

Figure 3. HiMAT RPRV control system.



ECN 10108

Figure 4. Typical RPRV ground cockpit.



*ECN 20969*

**DAST vehicle for active  
flutter suppression experiment**

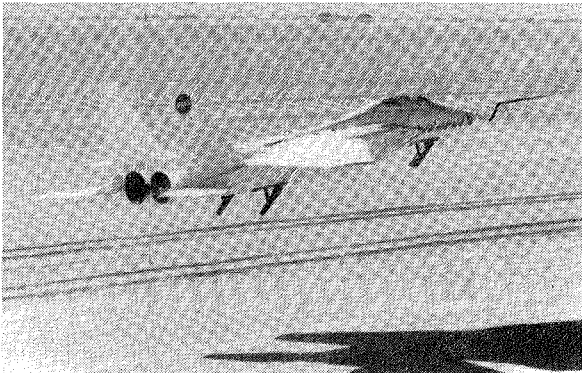

*ECN 4891*

**F-15 spin research  
vehicle**

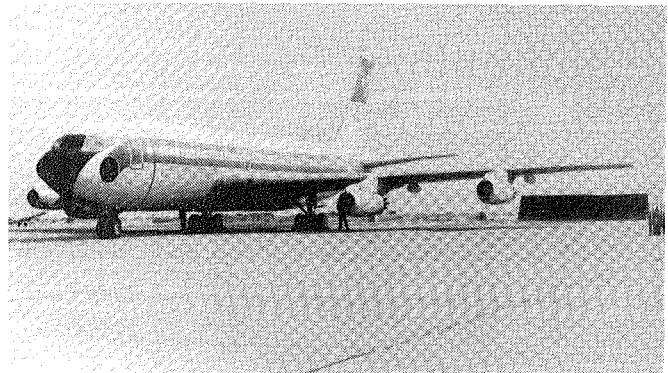

*ECN 28464*

**B-720 aircraft for controlled  
impact demonstration**

*Figure 5. High-risk RPRVs.*

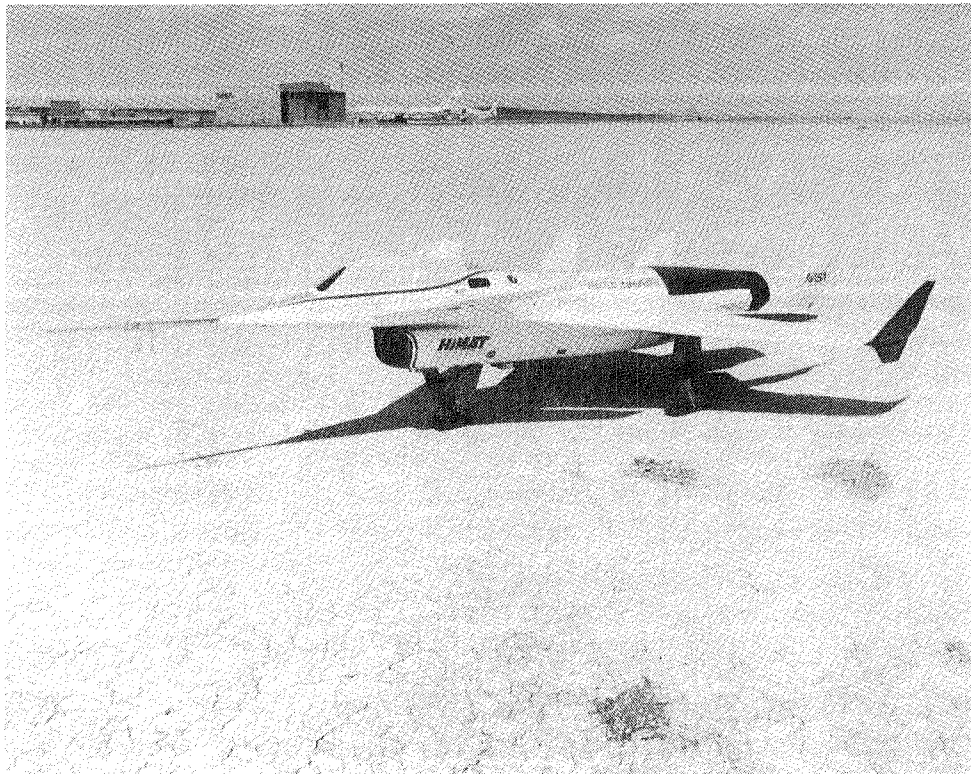

E-34909

Figure 6. HiMAT RPRV on Edwards dry lakebed.

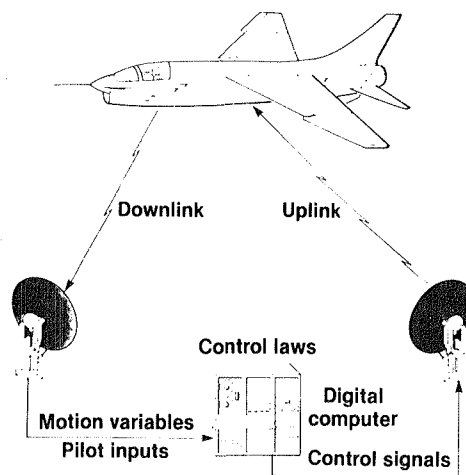

Figure 7. F-8 RAV flight test technique.

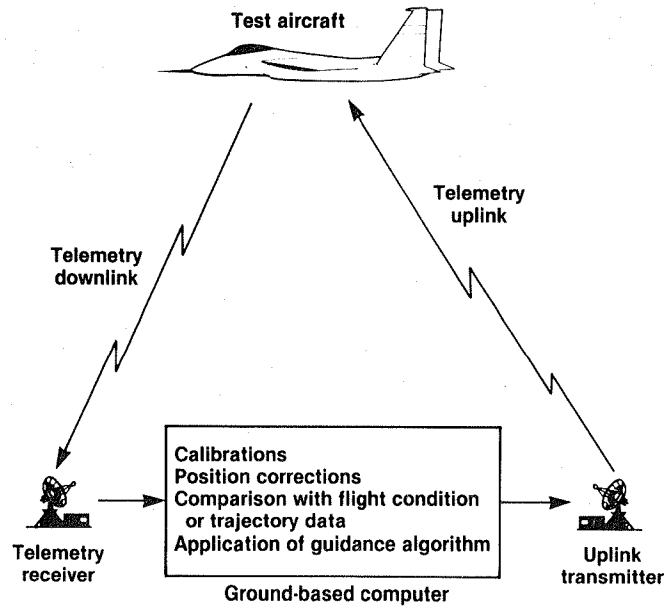

Figure 8. Remotely computed display system.

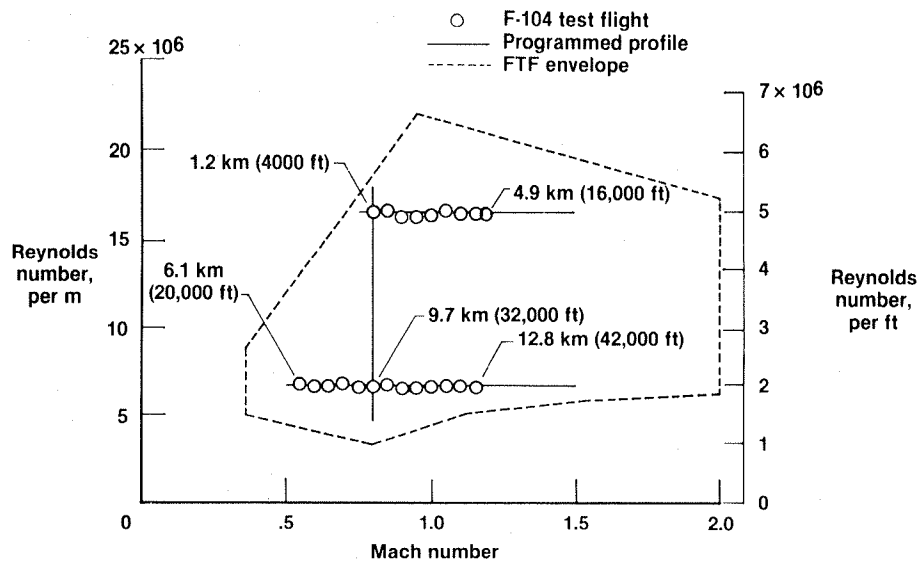

Figure 9. Typical Reynolds number-versus-Mach number trajectories flown with remotely computed display.

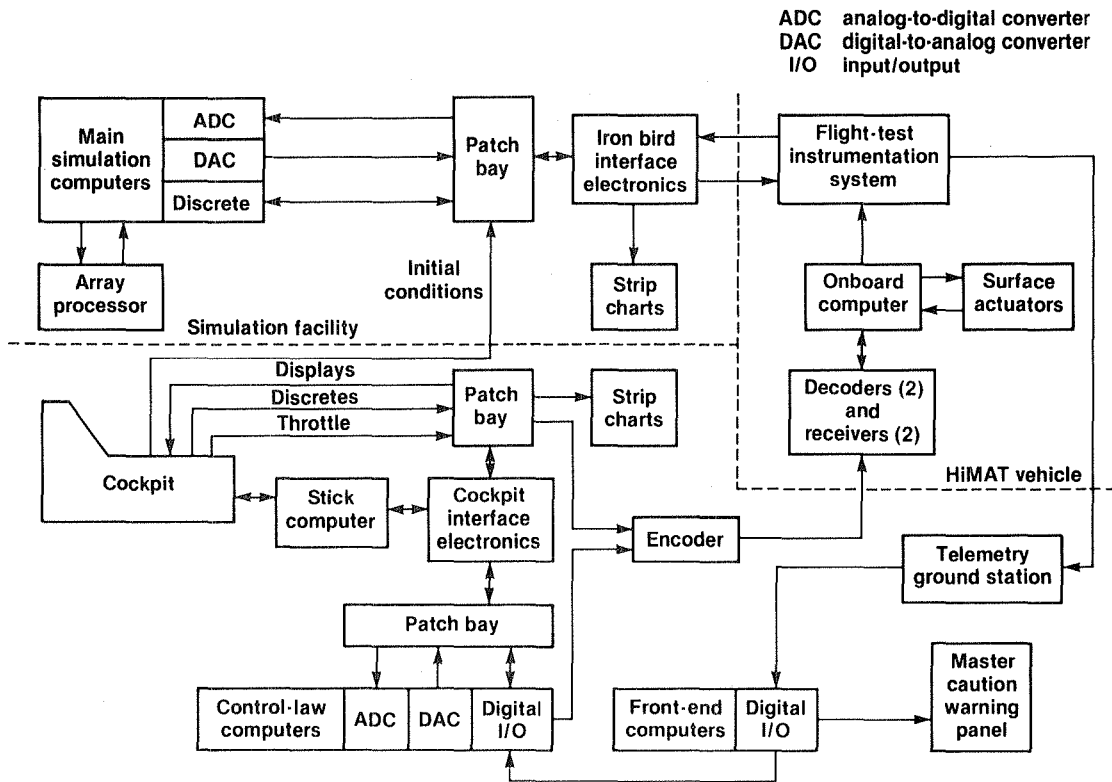

Figure 10. HiMAT iron bird simulation.

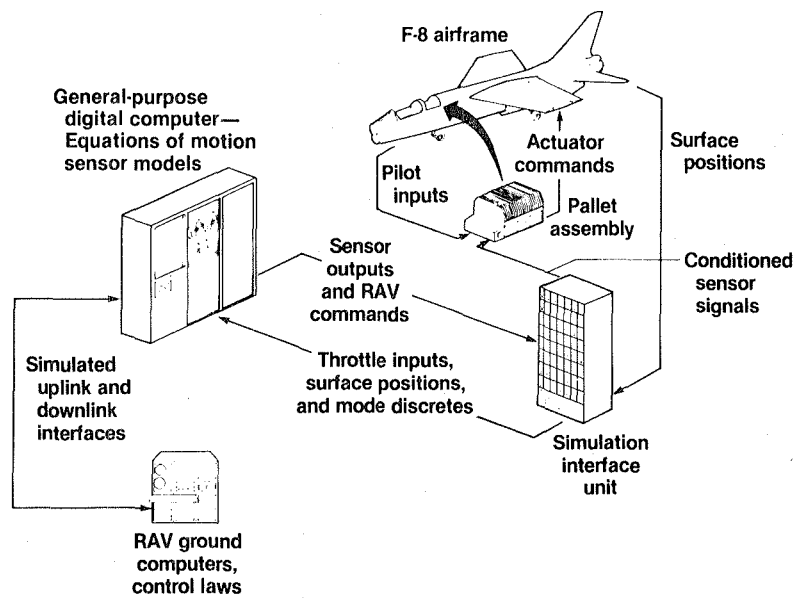

Figure 11. F-8 DFBW iron bird simulation facility configured for RAV system testing.

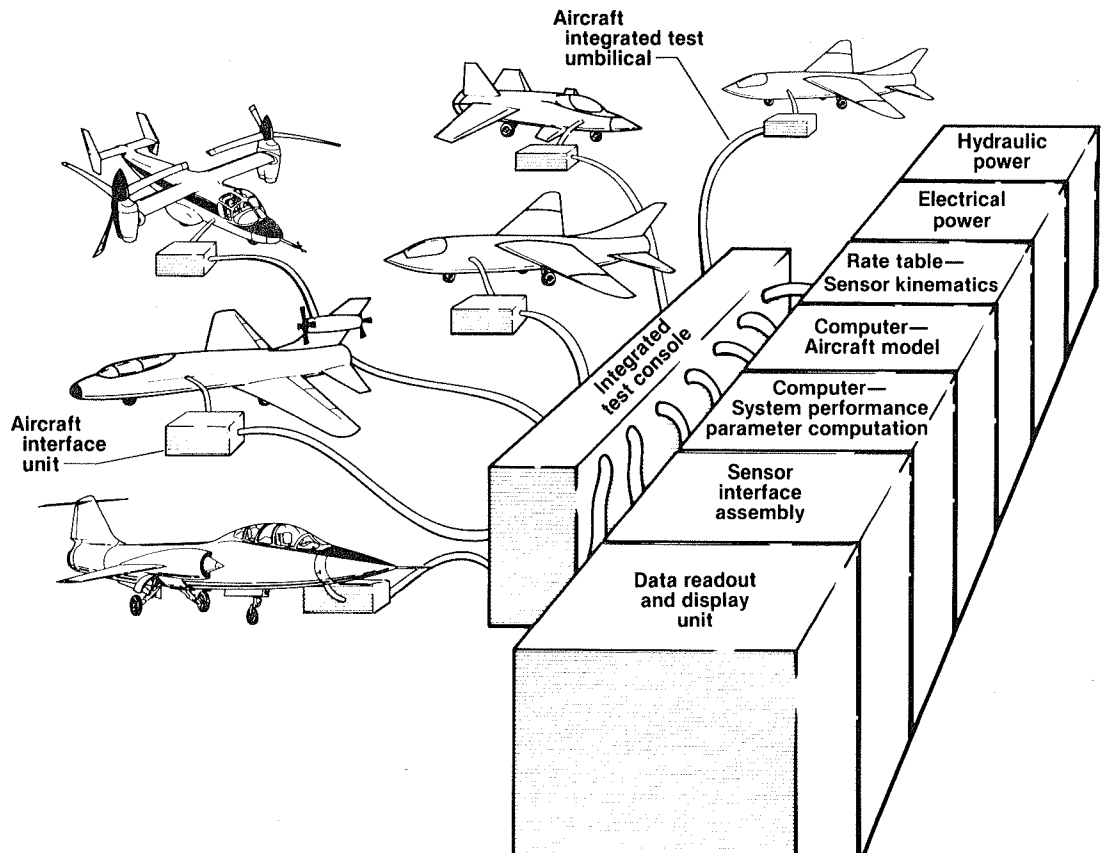
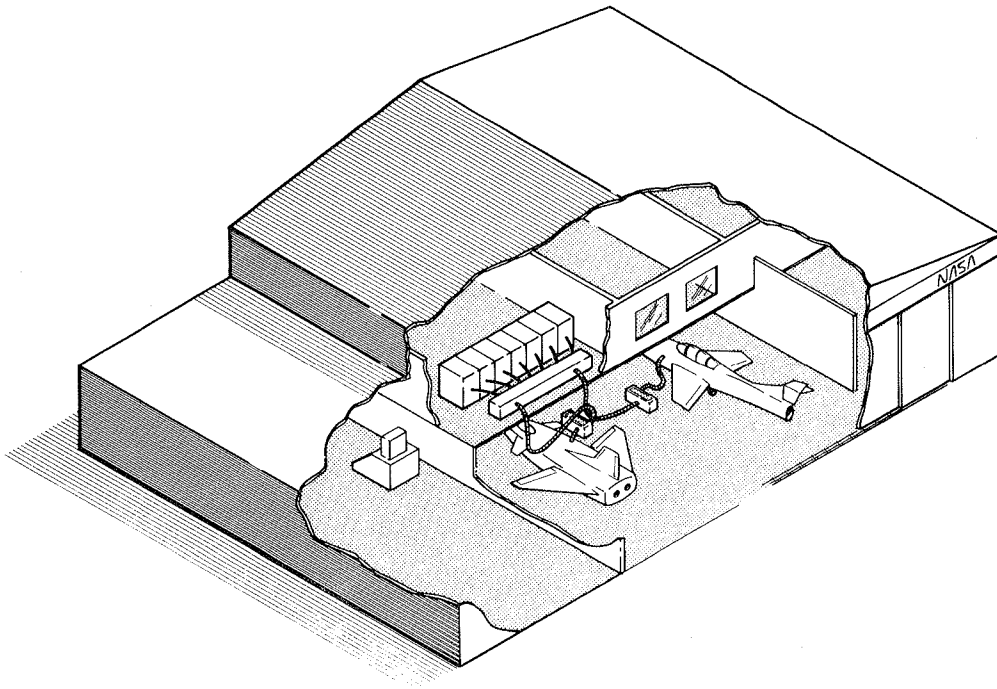

Figure 12. Integrated Test Facility.

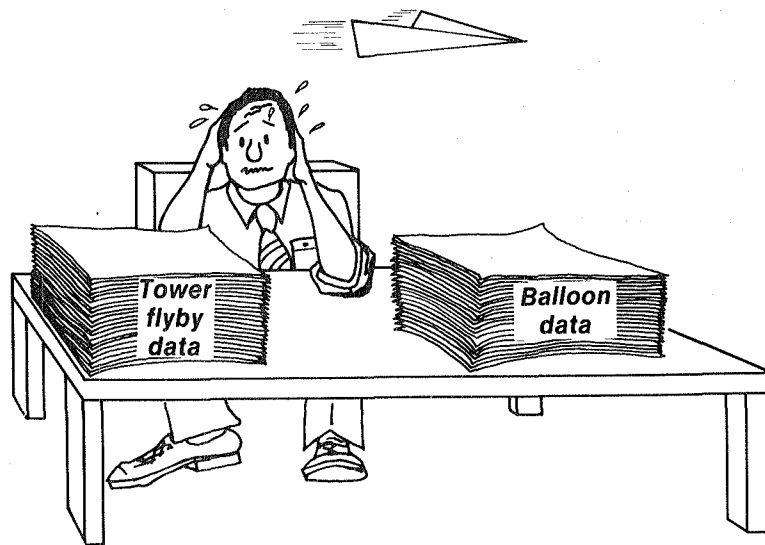

Figure 13. Traditional position-error correction.

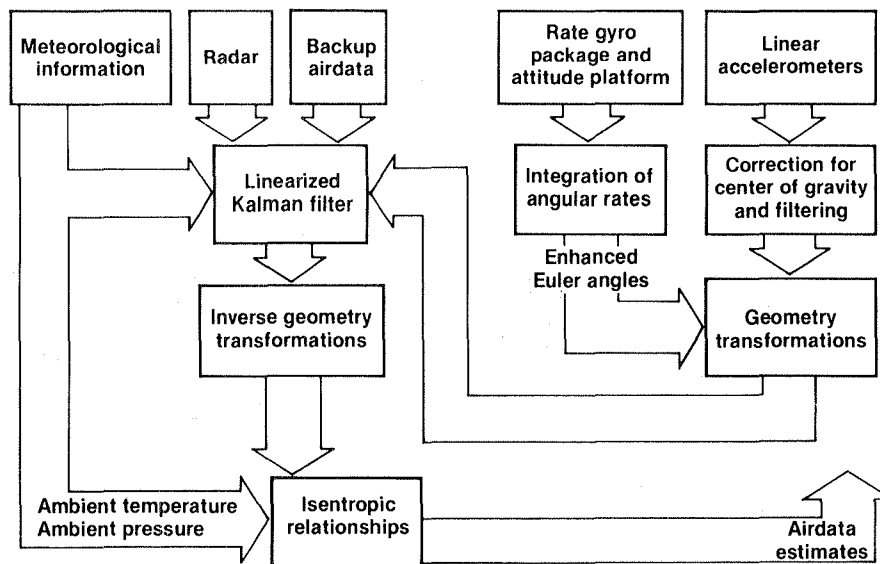

Figure 14. LKF computational scheme.

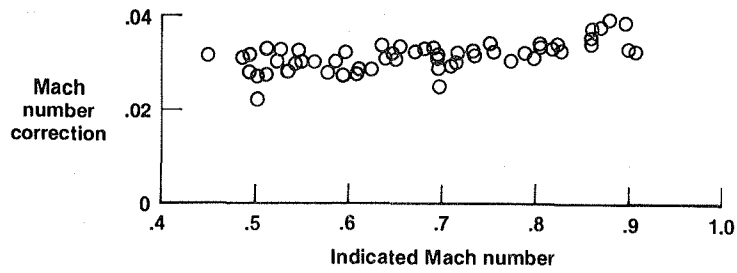

Figure 15. Original HiMAT position-error correction.

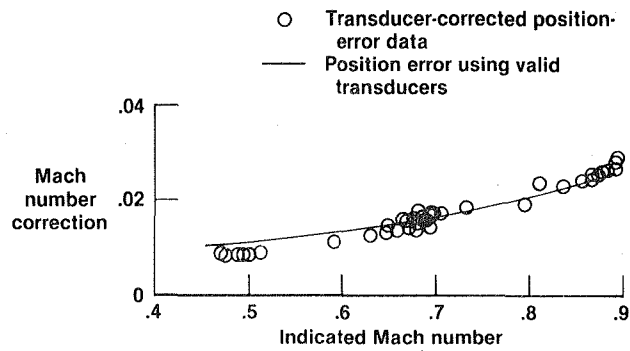
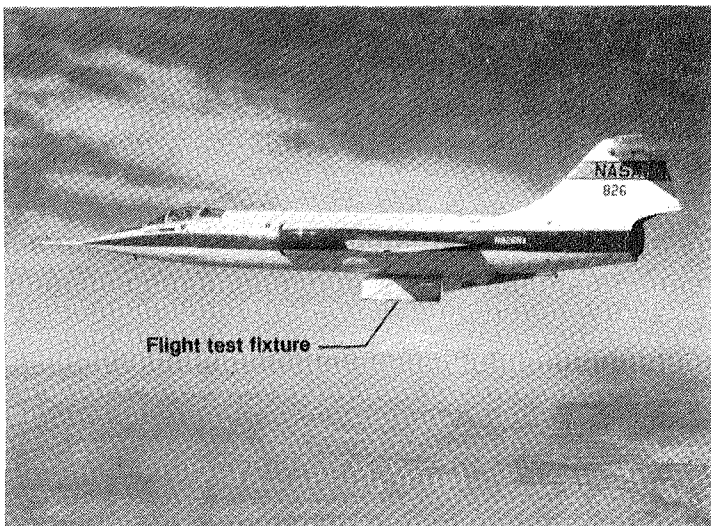
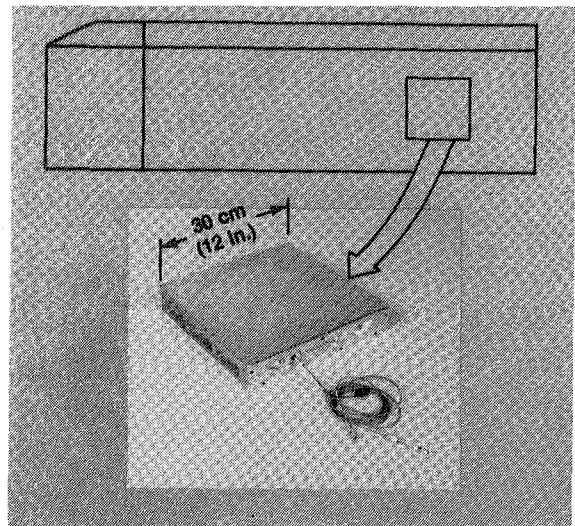

Figure 16. Comparison of corrected position error with position error determined using valid transducers.



ECN 18002

Figure 17. Flight test fixture installed on lower fuselage of F-104 carrier aircraft.



ECN 17910

Figure 18. Large force balance used for skin friction measurements.



1. Report No. NASA TM-86039		2. Government Accession No.		3. Recipient's Catalog No.	
4. Title and Subtitle A Review of Recent Developments in Flight Test Techniques at the Ames Research Center, Dryden Flight Research Facility				5. Report Date April 1984	
				6. Performing Organization Code	
7. Author(s) Garrison P. Layton				8. Performing Organization Report No. H-1237	
9. Performing Organization Name and Address NASA Ames Research Center Dryden Flight Research Facility P.O. Box 273 Edwards, California 93523				10. Work Unit No.	
				11. Contract or Grant No.	
12. Sponsoring Agency Name and Address National Aeronautics and Space Administration Washington, D.C. 20546				13. Type of Report and Period Covered Technical Memorandum	
				14. Sponsoring Agency Code	
15. Supplementary Notes  This paper was prepared for presentation at the Canadian Aeronautics and Space Institute (CASI) Flight Test Symposium, Cold Lake, Alberta, Canada, April 11-12, 1984.					
16. Abstract  This paper reviews some new flight test techniques in use at Ames Dryden. The use of the pilot in combination with ground and airborne computational capabilities to maximize data return is discussed, including the remotely piloted research vehicle technique for high-risk testing, the remotely augmented vehicle technique for handling qualities research, and use of ground-computed flight director information to fly unique profiles such as constant-Reynolds-number profiles through the transonic flight regime. Techniques used for checkout and design verification of systems-oriented aircraft are discussed, including descriptions of the various simulations, iron bird set-ups, and vehicle tests. Some newly developed techniques to support the aeronautical research disciplines are discussed, including a new approach to position-error determination, and the use of a large skin friction balance for the measurement of drag caused by various excrescencies.					
17. Key Words (Suggested by Author(s))  Test techniques Flight test Integrated systems			18. Distribution Statement  Unclassified-Unlimited  STAR category 05		
19. Security Classif. (of this report) Unclassified		20. Security Classif. (of this page) Unclassified		21. No. of Pages 15	22. Price* A02

\*For sale by the National Technical Information Service, Springfield, Virginia 22161.

**End of Document**