

General Disclaimer

One or more of the Following Statements may affect this Document

- This document has been reproduced from the best copy furnished by the organizational source. It is being released in the interest of making available as much information as possible.
- This document may contain data, which exceeds the sheet parameters. It was furnished in this condition by the organizational source and is the best copy available.
- This document may contain tone-on-tone or color graphs, charts and/or pictures, which have been reproduced in black and white.
- This document is paginated as submitted by the original source.
- Portions of this document are not fully legible due to the historical nature of some of the material. However, it is the best reproduction available from the original submission.



(NASA-CR-170999) SPACE SHUTTLE MAIN ENGINE
POWERHEAD STRUCTURAL MODELING, STRESS AND
FATIGUE LIFE ANALYSIS. VOLUME 1:
GASDYNAMIC ENVIRONMENT OF THE SSME HPFTP AND
HPOTP TURBINES Final (Lockheed Missiles and G3/20

N84-20635

Unclass
18780



 **Lockheed**
Missiles & Space Company
Huntsville Research & Engineering Center

4800 Bradford Drive, Huntsville, AL 35807

 **Lockheed**
Missiles & Space Company, Inc
Huntsville Research & Engineering Center

Cummings Research Park
4800 Bradford Drive
Huntsville, AL 35807

SPACE SHUTTLE MAIN ENGINE
POWERHEAD STRUCTURAL MODELING,
STRESS AND FATIGUE LIFE ANALYSIS

VOLUME I - GASDYNAMIC ENVIRONMENT
OF THE SSME HPFTP AND HPOTP TURBINES

December 1983

Contract NAS8-34978

Prepared for National Aeronautics and Space Administration
Marshall Space Flight Center, AL 35812

by

J.C. Hammett
C.H. Hayes
J.M. Price
J.K. Robinson
G.A. Teal
J.M. Thomson
D.M. Tilley
C.T. Welch

APPROVED



C.T. Welch, Manager (Acting)
Product Engineering & Development Section



S.V. Bourgeois
Director

FOREWORD

This report summarizes the results of work performed on Contract NAS8-34978. The work was performed by personnel of the Product Engineering & Development Section of Lockheed's Huntsville Research & Engineering Center, for the National Aeronautics and Space Administration, George C. Marshall Space Flight Center, Alabama. The Contracting Officer's technical representative for this study is Mr. Norman C. Schlemmer, Structures and Propulsion Laboratory, Engineering Analysis Division, Stress Analysis Branch (EP46).

This report is divided into four volumes with a section covering one aspect of analysis for all components and loads, and a fourth section for investigation of unscheduled events and special tasks undertaken during the effort. The volumes are:

- Volume I - Gasdynamic Environment of the SSME HPFTP and HPOTP Turbines, LMSC-HREC TR D867333-I.
- Volume II - Dynamics of Blades and Nozzles - SSME HPFTP and HPOTP, LMSC-HREC TR D867333-II.
- Volume III - Stress Summary of Blades and Nozzles at FPL and 115 percent RPL Loads SSME HPFTP and HPOTP Blades and Nozzles, LMSC-HREC TR D867333-III.
- Volume IV - Summary of Investigation of Unscheduled Events and Special Tasks, LMSC-HREC TR D867333-IV.

It should be noted that this report summarized our findings. A great body of data exists in the form of computer printout and magnetic tapes and is available to any interested reader for either amplification of the summarized data or as a basis for further work.

CONTENTS

<u>Section</u>		<u>Page</u>
	FOREWORD	ii
1	INTRODUCTION	1
2	GASDYNAMIC ANALYSIS FOR THE TURBINE BLADES AND NOZZLE VANES	2
	2.1 One-Dimensional Flow Analysis	2
	2.2 Flowfield Calculations Based on NASA-Lewis Codes Analysis	4
3	HPFTP TURBINE ANALYSIS	5
	3.1 One-Dimensional Analysis results	5
	3.2 NASA-Lewis Codes Analysis Results	5
4	HPOTP TURBINE ANALYSIS	20
	4.1 One-Dimensional Analysis Results	20
	4.2 NASA-Lewis Codes Analysis Results	20
	REFERENCES	28
Appendixes		
A	HPFTP First Stage Nozzle Pressure, Adiabatic Wall Temperature and Heat Transfer Coefficient Distributions	A-1
B	HPFTP First Stage Blade Pressure, Adiabatic Wall Temperature and Heat Transfer Coefficient Distributions	B-1
C	HPFTP Second Stage Blade Pressure, Adiabatic Wall Temperature and Heat Transfer Coefficient Distributions	C-1
D	HPFTP Second Stage Nozzle Pressure, Adiabatic Wall Temperature and Heat Transfer Coefficient Distributions	D-1

E	HPOTP First Stage Nozzle Pressure, Adiabatic Wall Temperature and Heat Transfer Coefficient Distributions	E-1
F	HPOTP First Stage Blade Pressure, Adiabatic Wall Temperature and Heat Transfer Coefficient Distributions	F-1
G	HPOTP Second Stage Nozzle Pressure, Adiabatic Wall Temperature and Heat Transfer Coefficient Distributions	G-1
H	HPOTP Second Stage Blade Pressure, Adiabatic Wall Temperature and Heat Transfer Coefficient Distributions	H-1

1. INTRODUCTION

The objectives of these analyses are to define the gasdynamic and thermal environments acting on the HPFTP and HPOTP nozzles and turbine blades during steady state engine operation. Flow analyses were performed for operation at full power level (FPL) and 115 percent of rated power level (RPL).

2. GASDYNAMIC ANALYSIS FOR THE TURBINE BLADES AND NOZZLE VANES

2.1 ONE-DIMENSIONAL FLOW ANALYSIS

One-dimensional models of the HPFTP and HPOTP turbines (Ref. 1) were used to generate average velocity and pressure data at the inlet and discharge of the turbine blades. Required program inputs consist of the following parameters:

1. Turbine inlet pressure and temperature
2. Turbine flow rate
3. Turbine discharge pressure
4. Pump speed.

Program output is described in Table 2-1.

The thermal environment in the first and second stage blade platform and shank regions was calculated based on hot gas leakage and turbine coolant flow rates obtained from the HPFTP and HPOTP turbine coolant models (Ref. 1). Heat transfer coefficients were computed using correlations for flow across a flat plate and a correlation for convection heat transfer in rotating systems (Ref. 2).

Laminar Flow

$$hcx = 0.332 \cdot K \cdot Re^{0.5} \cdot Pr^{0.333}/x$$

Turbulent Flow (Transition at $Re = 5 \times 10^5$)

$$hcx = 0.0288 \cdot K \cdot Re^{0.8} \cdot Pr^{0.333}/x$$

Table 2-1
 NOMENCLATURE FOR ONE-DIMENSIONAL TURBINE ANALYSES

Nomenclature:

- P_0 fluid total pressure, psia
- P fluid static pressure, psia
- T_0 fluid total temperature, R
- T fluid static temperature, R
- α fluid absolute flow angle, deg
- β fluid relative flow angle, deg
- C fluid absolute velocity, ft/sec
- V fluid tangential velocity, ft/sec
- u fluid axial velocity, ft/sec
- V_R fluid relative velocity, ft/sec
- u_T blade velocity, ft/sec
- \dot{w} turbine flow rate, lbm/sec
- RPM pump speed

Velocity Diagrams

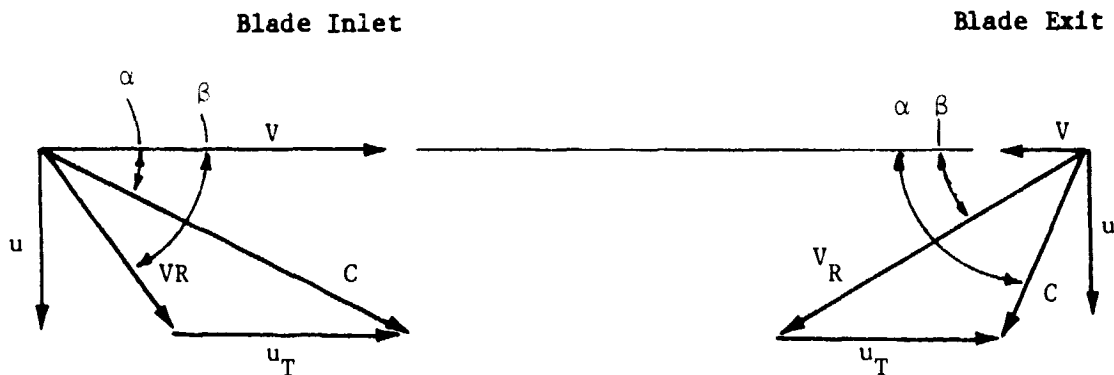

Rotating Systems

$$hc = 0.035 \cdot K \cdot (Re_{r_o})^{0.7} \cdot (Re_s)^{0.1} \cdot (r_i/r_o)^{0.3} \cdot (2a/r_o)^{1.06}/2a$$

where:

K is thermal conductivity

Re is the Reynolds no., $\rho \cdot V \cdot x / \mu$

Pr is the Prandtl no., $\mu \cdot cp / K$

X is the flow distance along the plate

Re_{r_o} is the rotational Reynolds no., $\rho \cdot \omega \cdot r_o^2 / \mu$

Re_s is the source flow Reynolds no., $\dot{w} / (4\pi \cdot a \cdot \mu)$

r_i is the inner radius of the rotating disk

r_o is the outer radius of the rotating disk

a is the gap between the rotating and stationary disks.

ω is the rotational velocity, rad/sec

\dot{w} is the flow rate, lbm/sec

2.2 FLOWFIELD CALCULATIONS BASED ON NASA-LEWIS CODES ANALYSIS

The gasdynamic environment of the HPFTP and HPOTP nozzle vanes and turbine blades was calculated with a set of three codes obtained from NASA-Lewis Research Center. The first step in the analysis uses an inviscid flow code designated MERIDL (Refs. 3 and 4) and determines the flow characteristics at the plane located at the midpoint between the two mean-camber lines of adjacent blades. The second step in the inviscid calculation procedure is the blade-to-blade calculation for each of eleven stream sheets using the code TSONIC (Ref. 5). By use of the MERIDL and TSONIC codes, a quasi three-dimensional calculation is effected.

The thermal environment experienced by the blade was determined by use of the boundary layer code BLAYER (Ref. 6). This code solves the two-dimensional, compressible, laminar and turbulent boundary layer equations in an arbitrary pressure gradient.

3. HPFTP TURBINE ANALYSIS

3.1 ONE-DIMENSIONAL ANALYSIS RESULTS

Average velocity and pressure data at the inlet and discharge of the turbine blades were computed as described in Section 2.1. Data were computed at the FPL and 115 percent power levels using revision F engine balance data. Results of these analyses are presented in Table 3-1.

The thermal environment in the platform and shank region of the turbine blades was also computed at both power levels. Coolant and hot gas leakage flow data used in the analysis are shown in Table 3-2. Results are presented in Tables 3-3 through 3-12. The heat transfer correlations and method of analysis are described in Section 2.1.

3.2 NASA-LEWIS CODES ANALYSIS RESULTS

The computer codes described in Section 2.2 were used to generate thermal and pressure loads for the HPFTP turbine nozzles and blades at the FPL and 115 percent power levels. Input data were obtained from Revision F engine balance data and from the one-dimensional analysis results shown in Table 3-1. Analysis results for vane pressure, heat transfer coefficient and adiabatic wall temperature profiles at five radial locations are contained in Appendixes A through D.

Pressure data obtained from the BLAYER program were integrated over the vane surface to obtain the net torque force on the first and second stage blades. These forces are compared to approximate values based on the torque obtained from engine balance data in Table 3-13. The forces obtained from engine balance data are approximately 10 percent higher than those obtained

from the NASA-Lewis codes analysis. Part of this discrepancy is due to smoothing of the pressure profile data which is required to obtain execution of the BLAYER program.

Table 3-1

AVERAGE FLUID PROPERTIES AT INLET AND DISCHARGE
OF HPFTP TURBINE BLADES AT THE MEAN DIAMETER

	FPL		115 Percent	
	First Stage Blade	Second Stage Blade	First Stage Blade	Second Stage Blade
Blade Inlet				
P ₀	5564.7	4481.5	6009.1	4831.8
P	4784.0	3838.3	5151.1	4119.5
T ₀	1993.6	1906.8	1941.5	1854.3
T	1917.4	1831.7	1865.6	1778.7
α	24.5	26.75	24.5	26.75
β	54.7	59.0	56.3	60.4
C	2678.0	2650.6	2685.6	2669.4
V	2436.9	2366.9	2443.8	2383.7
u	110.6	1193.0	1113.7	1201.5
VR	1361.6	1392.3	1338.6	1381.9
u _T	1649.14	1649.14	1700.98	1700.98
w	160.78	162.18	176.34	177.74
RPM	37091.0	37091.0	38257.0	38257.0
Blade Exit				
P ₀	4555.3	3665.1	4900.4	3932.8
P	4427.1	3557.5	4761.1	3815.7
T ₀	1903.7	1809.4	1850.9	1757.5
T	1889.7	1795.4	1837.1	1743.7
α	77.4	79.2	79.5	81.3
β	30.5	31.1	30.5	31.1
C	1146.4	1145.0	1143.7	1143.5
V	250.2	215.1	208.2	172.9
u	1118.8	1124.6	1124.6	1130.4
VR	2204.4	2177.2	2215.7	2188.4
u _T	1649.14	1649.14	1700.98	1700.98
w	160.78	162.18	176.34	177.74
RPM	37091.0	37091.0	38257.0	38257.0

ORIGINAL PAGE IS
OF POOR QUALITY

Table 3-2
HPFTP TURBINE COOLANT AND LEAKAGE FLOW ANALYSIS

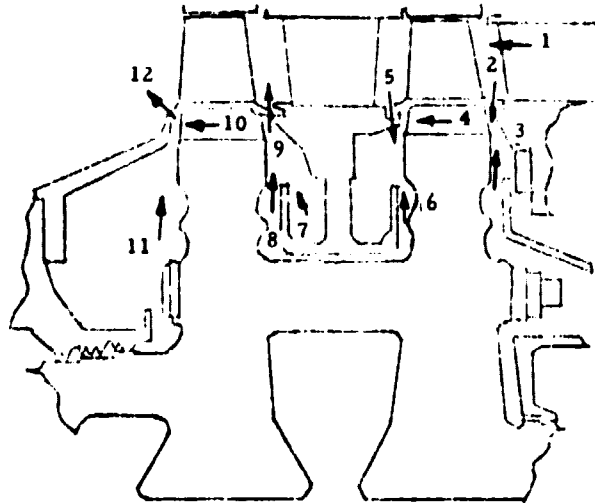

Flow Path	FPL			115 Percent		
	Flow Rate (lbm/sec)	Temperature (R)	Pressure (psia)	Flow Rate (lbm/sec)	Temperature (R)	Pressure (psia)
1	164.18	1917	4784	179.74	1865	5151
2	3.90	1993	4230	4.27	1941	4540
3	0.52	147	↕	0.51	152	↕
4	4.42	1610		4.78	1604	
5	2.15	1903	↕	2.36	1850	↕
6	0.52	155	4230	0.52	161	4540
7	7.09	1513	4215	7.66	1513	4525
8	0.24	155	4215	0.26	161	4525
9	3.68	1438	3838	3.97	1439	4120
10	3.65	1435	4205	3.95	1437	4515
11	0.36	145	4205	0.36	151	4515
12	4.02	1221	3558	4.31	1279	3816

ORIGINAL PAGE IS
OF POOR QUALITY

Table 3-3

HPFTP FIRST STAGE ROTOR BLADE (TOP OF PLATFORM)
GAS FILM COEFFICIENTS AND ADIABATIC WALL TEMPERATURES

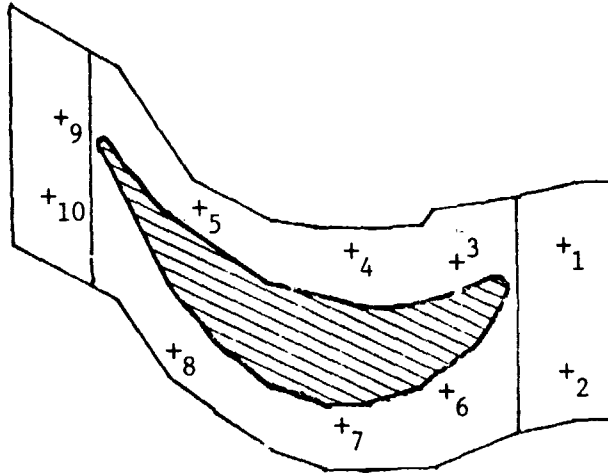

Sta. No.	Heat Transfer Coefficients (Btu/in ² -sec-F)		Adiabatic Wall Temperatures (F)	
	FPL	115 Percent Power Level	FPL	115 Percent Power Level
1	.012	.013	1535	1485
2	.012	.013	1535	1485
3	.028	.030	1475	1425
4	.025	.027	1475	1425
5	.030	.032	1475	1425
6	.027	.029	1475	1425
7	.026	.028	1475	1425
8	.030	.033	1475	1425
9	.031	.033	1475	1425
10	.031	.033	1475	1425

ORIGINAL PAGE 19
OF POOR QUALITY

Table 3-4

HPFTP FIRST STAGE ROTOR BLADE (BOTTOM OF PLATFORM)
GAS FILM COEFFICIENTS AND ADIABATIC WALL TEMPERATURES

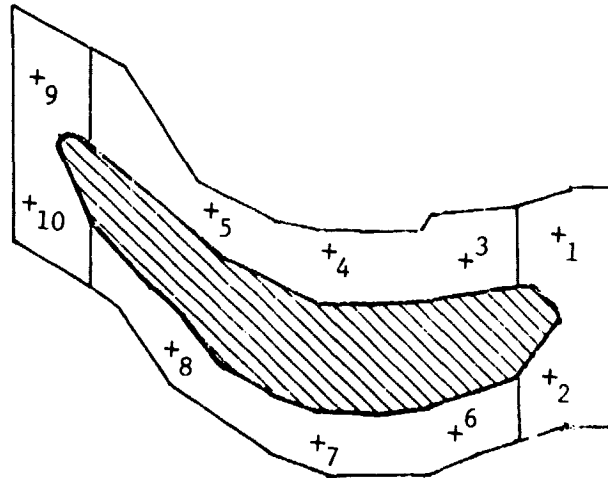

Sta. No.	Heat Transfer Coefficients (Btu/in ² -sec-F)		Adiabatic Wall Temperatures (F)	
	FPL	115 Percent Power Level	FPL	115 Percent Power Level
1	.012	.013	1535	1485
2	.012	.013	1535	1485
3	.0030	.0031	1493	1446
4	.0016	.0017	1363	1331
5	.0013	.0013	1255	1237
6	.0018	.0018	1458	1415
7	.0013	.0013	1322	1296
8	.0049	.0052	1178	1169
9	.011	.012	1445	1392
10	.011	.012	1445	1392

Table 3-5
HPFTP FIRST STAGE ROTOR BLADE (SHANK) GAS FILM
COEFFICIENTS AND ADIABATIC WALL TEMPERATURES

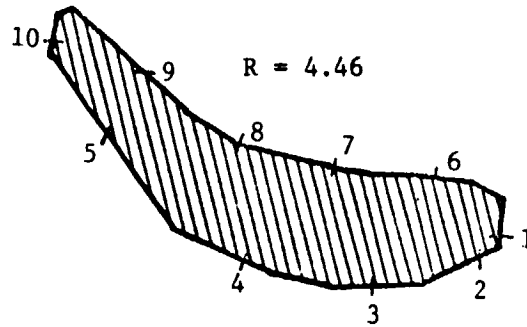

Sta. No.	Heat Transfer Coefficients (Btu/in ² -sec-F)		Adiabatic Wall Temperatures (F)	
	FPL	115 Percent Power Level	FPL	115 Percent Power Level
1	.012	.013	1153	1112
2	.0026	.0027	1149	1111
3	.0015	.0016	1150	1123
4	.0053	.0056	1151	1135
5	.0049	.0052	1152	1144
6	.0036	.0037	1148	1110
7	.0018	.0019	1150	1120
8	.0014	.0014	1151	1130
9	.0051	.0055	1152	1141
10	.012	.013	1309	1282

ORIGINAL PAGE IS
OF POOR QUALITY

Table 3-6
HPFTP FIRST STAGE ROTOR BLADE (SHANK) GAS FILM
COEFFICIENTS AND ADIABATIC WALL TEMPERATURES

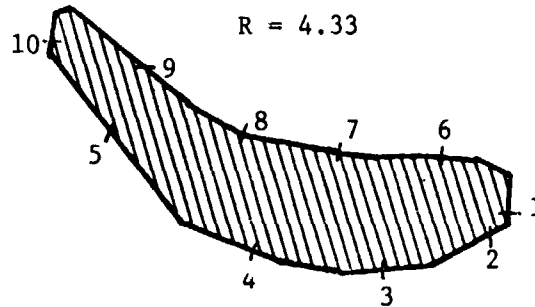

Sta. No.	Heat Transfer Coefficients (Btu/in ² -sec-F)		Adiabatic Wall Temperatures (F)	
	FPL	115 Percent Power Level	FPL	115 Percent Power Level
1	.014	.015	443	437
2	.0030	.0031	541	522
3	.0016	.0017	750	736
4	.0058	.0061	941	932
5	.0051	.0054	1096	1089
6	.0032	.0033	545	525
7	.0017	.0018	732	717
8	.0061	.0065	885	873
9	.0053	.0056	1050	1042
10	.013	.014	1264	1243

Table 3-7

HPFTP FIRST STAGE ROTOR BLADE (SHANK) GAS FILM
COEFFICIENTS AND ADIABATIC WALL TEMPERATURES

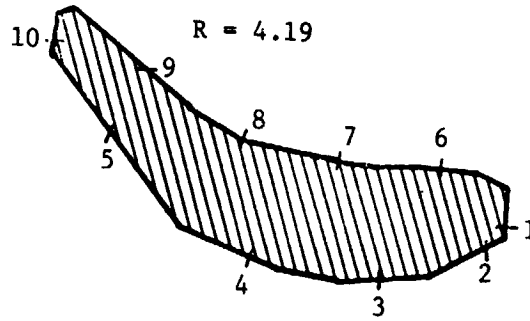

Sta. No.	Heat Transfer Coefficients (Btu/in ² -sec-F)		Adiabatic Wall Temperatures (F)	
	FPL	115 Percent Power Level	FPL	115 Percent Power Level
1	.039	.041	-312	-307
2	.030	.031	-163	-159
3	.0089	.0091	204	205
4	.0069	.0073	542	541
5	.0058	.0061	852	848
6	.030	.031	-163	-159
7	.0089	.0091	204	205
8	.0069	.0073	542	541
9	.0058	.0061	852	848
10	.014	.015	1242	1223

Table 3-8

HPFTP SECOND STAGE ROTOR BLADE (TOP OF PLATFORM) GAS FILM
COEFFICIENTS AND ADIABATIC WALL TEMPERATURES

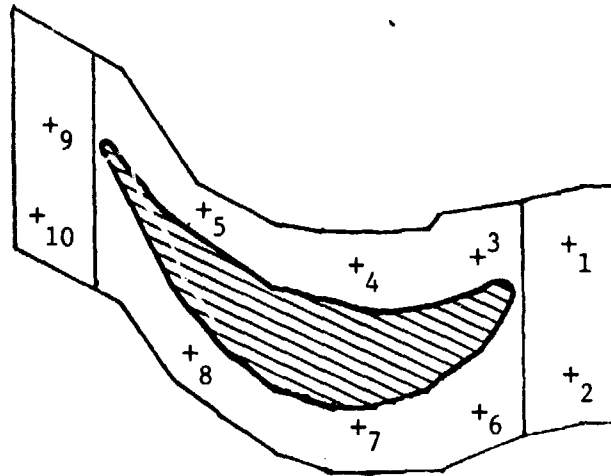

Sta. No.	Heat Transfer Coefficients (Btu/in ² -sec-F)		Adiabatic Wall Temperatures (F)	
	FPL	115 Percent Power Level	FPL	115 Percent Power Level
1	.015	.016	976	976
2	.015	.016	976	976
3	.024	.026	1392	1340
4	.021	.023	1392	1340
5	.025	.027	1392	1340
6	.023	.025	1392	1340
7	.022	.024	1392	1340
8	.026	.028	1392	1340
9	.026	.028	1392	1340
10	.026	.028	1392	1340

Table 3-9

HPFTP SECOND STAGE ROTOR BLADE (BOTTOM OF PLATFORM) GAS FILM
COEFFICIENTS AND ADIABATIC WALL TEMPERATURES

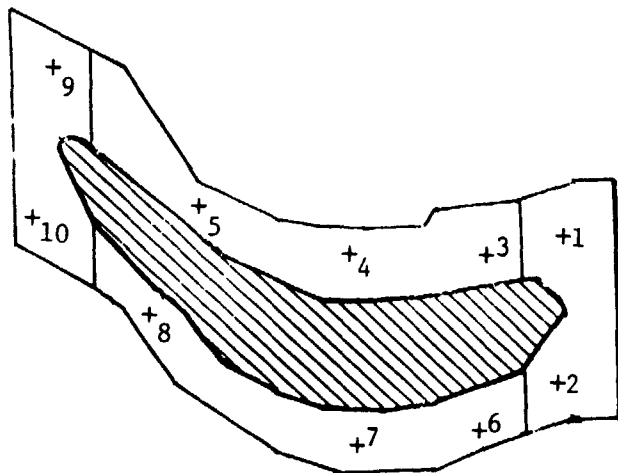

Sta. No.	Heat Transfer Coefficients ($Etu/in^2\text{-sec-F}$)		Adiabatic Wall Temperatures (F)	
	FPL	115 Percent Power Level	FPL	115 Percent Power Level
1	.015	.017	977	977
2	.015	.017	977	977
3	.0028	.0029	977	977
4	.0015	.0015	977	977
5	.0012	.0012	977	977
6	.0017	.0017	977	977
7	.0012	.0012	977	977
8	.0043	.0046	977	977
9	.015	.017	787	801
10	.015	.017	787	801

Table 3-10

HPFTP SECOND STAGE ROTOR BLADE (SHANK) GAS FILM
COEFFICIENTS AND ADIABATIC WALL TEMPERATURES

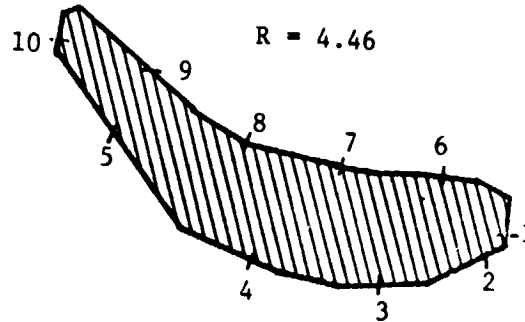

Sta. No.	Heat Transfer Coefficients (Btu/in ² -sec-F)		Adiabatic Wall Temperatures (F)	
	FPL	115 Percent Power Level	FPL	115 Percent Power Level
1	.015	.016	977	977
2	.0024	.0024	977	977
3	.0014	.0014	977	977
4	.0011	.0049	977	977
5	.0043	.0046	977	977
6	.0032	.0034	977	977
7	.0016	.0017	977	977
8	.0012	.0013	977	977
9	.0045	.0048	977	977
10	.015	.017	773	788

Table 3-11
HPFT? SECOND STAGE ROTOR BLADE (SHANK) GAS FILM
COEFFICIENTS AND ADIABATIC WALL TEMPERATURES

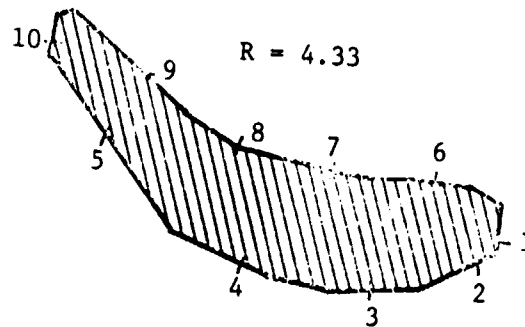

Sta. No.	Heat Transfer Coefficients (Btu/in ² -sec-F)		Adiabatic Wall Temperatures (F)	
	FPL	115 Percent Power Level	FPL	115 Percent Power Level
1	.015	.016	977	977
2	.0024	.0025	977	977
3	.0014	.0014	977	977
4	.0011	.0049	977	977
5	.0044	.0046	977	977
6	.0026	.0027	977	977
7	.0015	.0015	977	977
8	.0012	.0012	977	977
9	.0045	.0047	977	977
10	.015	.016	640	661

Table 3-12

HPFTP SECOND STAGE ROTOR BLADE (SHANK) GAS FILM
COEFFICIENTS AND ADIABATIC WALL TEMPERATURES

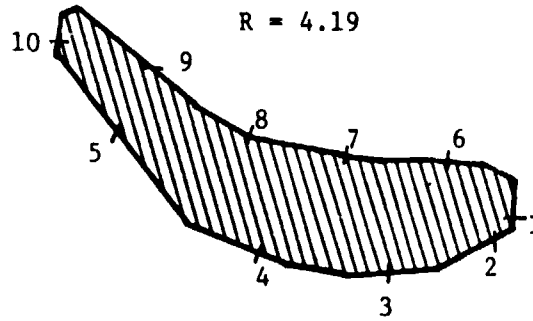

Sta. No.	Heat Transfer Coefficients (Btu/in ² -sec-F)		Adiabatic Wall Temperatures (F)	
	FPL	115 Percent Power Level	FPL	115 Percent Power Level
1	.015	.016	977	977
2	.0024	.0025	977	977
3	.0014	.0015	977	977
4	.0011	.0011	977	977
5	.0045	.0047	977	977
6	.0024	.0025	977	977
7	.0014	.0015	977	977
8	.0011	.0011	977	977
9	.0045	.0047	977	977
10	.038	.040	-304	-298

Table 3-13
HPFTP TURBINE BLADE TORQUE FORCES (lbf)

	FPL		115 Percent	
	BLAYER Program	Approximate (based on engine balance data)	BLAYER Program	Approximate (based on engine balance data)
First Stage	188	209	204	226
Second Stage	191	213	209	231

4. HPOTP TURBINE ANALYSIS

4.1 ONE-DIMENSIONAL ANALYSIS RESULTS

The one-dimensional turbine program (described in Section 2.1) was used to generate average velocity and pressure data at the inlet and discharge of the turbine blades. Data were computed at the FPL and 115 percent power levels using revision F engine balance data. Results of these analyses are presented in Table 4-1.

Coolant and hot gas leakage flow data for the HPOTP nozzles and blades are shown in Fig. 4-1 and Table 4-2. These data were used to generate the thermal environment in the platform and shank region of the turbine blades (Tables 4-3 and 4-4). The heat transfer correlations and method of analysis are described in Section 2.1.

4.2 NASA-LEWIS CODES ANALYSIS RESULTS

The computer codes described in Section 2-2 were used to generate thermal and pressure loads for the HPOTP turbine nozzles and blades at the FPL and 115 percent levels. Input data were obtained from Revision F engine balance data and from the one-dimensional analysis results shown in Table 3-1. Analysis results for vane pressure, heat transfer coefficient and adiabatic wall temperature profiles at three radial locations are contained in Appendixes E through H.

Pressure data obtained from the BLAYER program were integrated over the vane surface to obtain the net torque force on the first and second stage blades. These forces are compared to approximate values based on the torque obtained from engine balance data in Table 4-5. The forces obtained from

engine balance data are 8 to 15 percent higher than those obtained from the NASA-Lewis codes analysis. Part of this discrepancy is due to smoothing of the pressure profile data which is required to obtain execution of the BLAYER Program.

Table 4-1

AVERAGE FLUID PROPERTIES AT INLET AND DISCHARGE
OF HPOTP TURBINE BLADES AT THE MEAN DIAMETER

	FPL		115 Percent*	
	First Stage Blade	Second Stage Blade	First Stage Blade	Second Stage Blade
	Blade Inlet			
P _O	5459.5	4219.3	5980.5	4580.7
P	4182.1	3664.7	4537.9	3948.5
T _O	1499.8	1407.0	1686.0	1585.1
T	1395.4	1354.2	1566.5	1523.4
α	16.0	22.5	16.0	22.5
β	26.2	46.8	26.1	46.0
C	3327.6	2368.7	3648.2	2494.5
V	3198.7	2188.4	3333.9	2304.6
u	917.2	906.5	956.0	954.6
VR	2075.4	1243.6	2172.7	1327.0
u _T	1336.94	1336.94	1382.81	1382.81
w	66.73	67.85	72.00	73.18
RPM	30367.0	30367.0	31409.0	31409.0
	Blade Exit			
P _O	4271.8	3597.0	4640.7	3874.5
P	4152.5	3534.2	4504.6	3802.5
T _O	1404.6	1342.8	1582.5	1511.7
T	1393.9	1336.4	1570.0	1504.1
α	69.9	85.6	69.1	83.6
β	30.5	30.5	30.5	30.5
C	1069.4	827.5	1125.0	877.4
V	367.8	63.8	401.3	97.4
u	1004.2	825.1	1050.9	871.9
VR	1978.5	1625.7	2070.6	1717.9
u _T	1336.94	1336.94	1382.81	1382.81
w	66.73	67.85	72.00	73.18
RPM	30367.0	30367.0	31409.0	31409.0

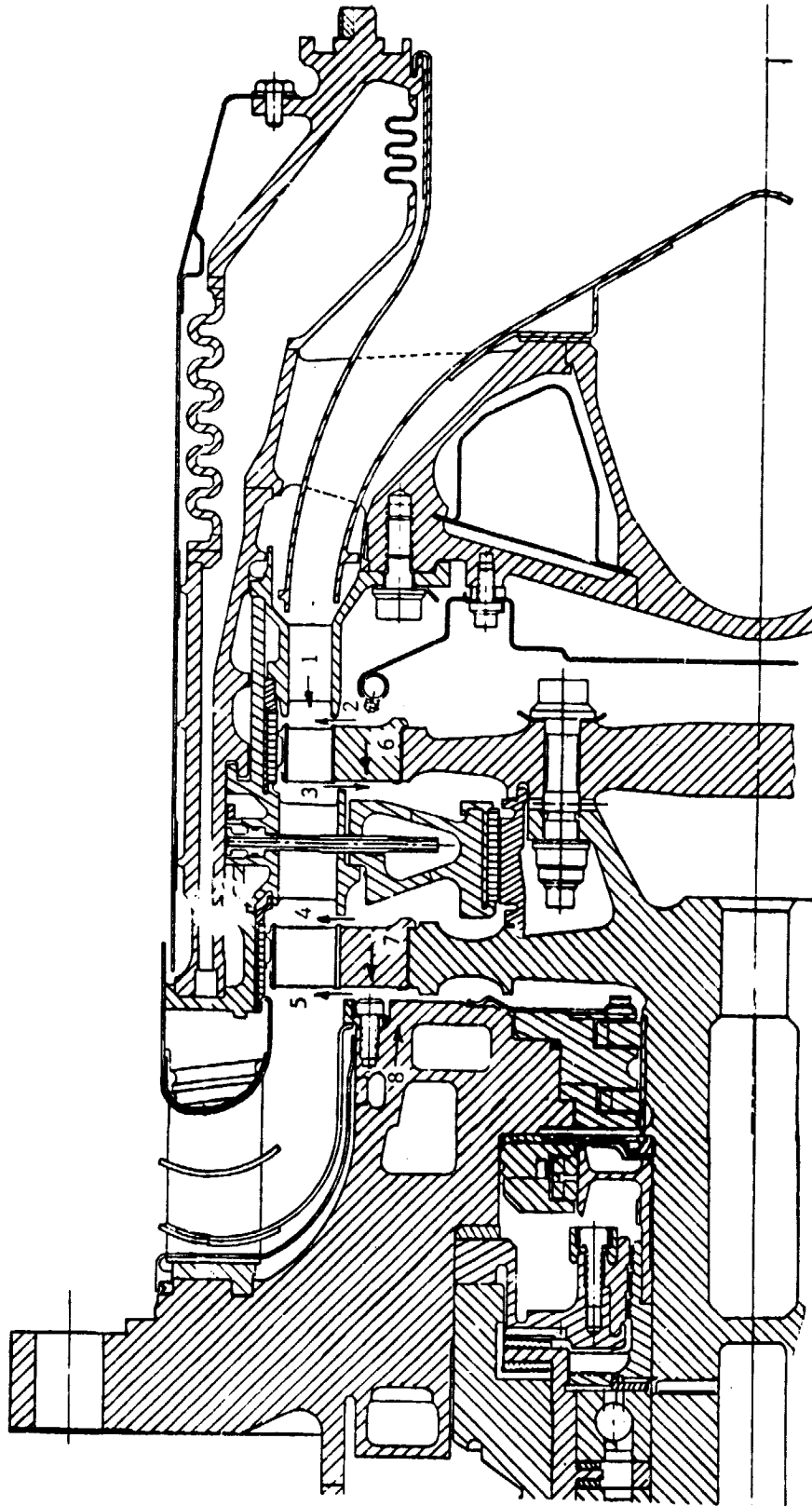

Fig. 4-1 HPOTP Turbine Coolant and Leakage Flow Analysis

Table 4-2
 HPOTP TURBINE COOLANT AND LEAKAGE FLOW ANALYSIS

Flow Path	FPL			115 Percent		
	Flow Rate (lbm/sec)	Temperature (R)	Pressure (psia)	Flow rate (lbm/sec)	Temperature (R)	Pressure (psia)
1	65.88	1395	4180	71.11	1565	4540
2	0.84	715	4180	0.88	790	4540
3	1.47	1395	4150	1.57	1570	4505
4	2.60	1025	3665	2.78	1145	3950
5	0.09	810	3535	0.10	895	3800
6	0.09	715	4180	0.11	790	4540
7	0.17	1025	3665	0.18	1145	3950
8	0.39	715	3535	0.42	795	3800

Table 4-3

HPOTP FIRST STAGE ROTOR BLADE SHANK, PLATFORM AND SHROUD
GAS FILM COEFFICIENTS AND ADIABATIC WALL TEMPERATURES

Zone	Description	Heat Transfer Coeff. (Btu/in ² -sec-F)		Adiabatic Wall Temp. (F)	
		FPL	115 Percent	FPL	115 Percent
1	Front Face of Shank	.018	.017	255	330
2	Back Face of Shank	.013	.013	950	1130
3	Sides of Shank	.00014	.00016	255	330
4	Under Side of Platform	Same as zones 1 and 2 at front and back, same as zone 3 on sides.			
5	Top of Platform	Interpolation of pressure and suction side airfoil data at the hub (see Section 4.2).			
6	Bottom of Shroud	Interpolation of pressure and suction side airfoil data at the tip (see Section 4.2).			

Table 4-4

HPOTP SECOND STAGE ROTOR BLADE SHANK, PLATFORM AND SHROUD GAS
FILM COEFFICIENTS AND ADIABATIC WALL TEMPERATURES

Zone	Description	Heat Transfer Coeff. (Btu/in ² -sec-F)		Adiabatic Wall Temp. (F)	
		FPL	115 Percent	FPL	115 Percent
1	Front Face of Shank	.015	.016	580	700
2	Back Face of Shank	.012	.012	350	435
3	Both Sides of Shank	.0002	.0002	580	700
4	Under Side of Platform	Same as zones 1 and 2 at front and back, same as zone 3 on sides.			
5	Top of Platform	Interpolation of pressure and suction side airfoil data at the hub (see Section 4.2)			
6	Bottom of Shroud	Interpolation of pressure and suction side airfoil data at the tip (see Section 4.2)			

Table 4-5

HPOTP TURBINE BLADE TORQUE FORCES (LBF)

	FPL		115 percent	
	BLAYER Program	Approximate (based on engine balance data)	BLAYER Program	Approximate (based on engine balance data)
First Stage	80	92	90	97
Second Stage	57	66	65	70

REFERENCES

1. Teal, G.A., "SSME Turbopump Flow Models - User's Manual," LMSC-HREC TR D867623, Lockheed Missiles & Space Company, Huntsville, Ala., October 1982.
2. Keith, F., Advances in Heat Transfer Vol. 5, Academic Press, New York, 1968, p. 192.
3. Katsanis, Theodore, and W.D. McNally, "Revised FORTRAN Program for Calculating Velocities and Streamlines on the Hub-Shroud Mid-Channel Stream Surface of an Axial-, Radial-, or Mixed-Flow Turbomachine or Annular Duct - Vol. II - Programmer's Manual," NASA TN D-8431, July 1977.
4. Katsanis, Theodore, and W.D. McNally, "Revised FORTRAN Program for Calculating Velocities and Streamlines on the Hub-Shroud Mid-Channel Stream Surface of an Axial-, Radial-, or Mixed-Flow Turbomachine or Annular Duct - Vol. I - User's Manual," NASA TN D-8430, March 1977.
5. Katsanis, Theodore, "FORTRAN Program for Calculating Transonic Velocities on a Blade-to-Blade Stream Surface of a Turbomachine," NASA TND-5427, September 1969.
6. McNally, William D., "FORTRAN Program for Calculating Compressible Laminar and Turbulent Boundary Layers in Arbitrary Pressure Gradients," NASA TN D-5681, May 1970.

Appendix A

HPFTP FIRST STAGE NOZZLE PRESSURE, ADIABATIC WALL
TEMPERATURE AND HEAT TRANSFER
COEFFICIENT DISTRIBUTIONS

- A.1 FPL Pressure Distributions
- A.2 115 Percent Power Level Pressure Distributions
- A.3 FPL Heat Transfer Coefficients
- A.4 115 Percent Power Level Heat Transfer Coefficients

Surface 1 - Pressure Surface \triangle
Surface 2 - Suction Surface \square

Approximate Adiabatic Wall
Temperatures (F)

	FPL	115 Percent
Case 1 - R = 4.5965 Hub	1530	1476
Case 2 - R = 4.79 Intermediate	↓	↓
Case 3 - R = 5.033 Mean		
Case 4 - R = 5.23 Intermediate		
Case 5 - R = 5.4695 Tip		

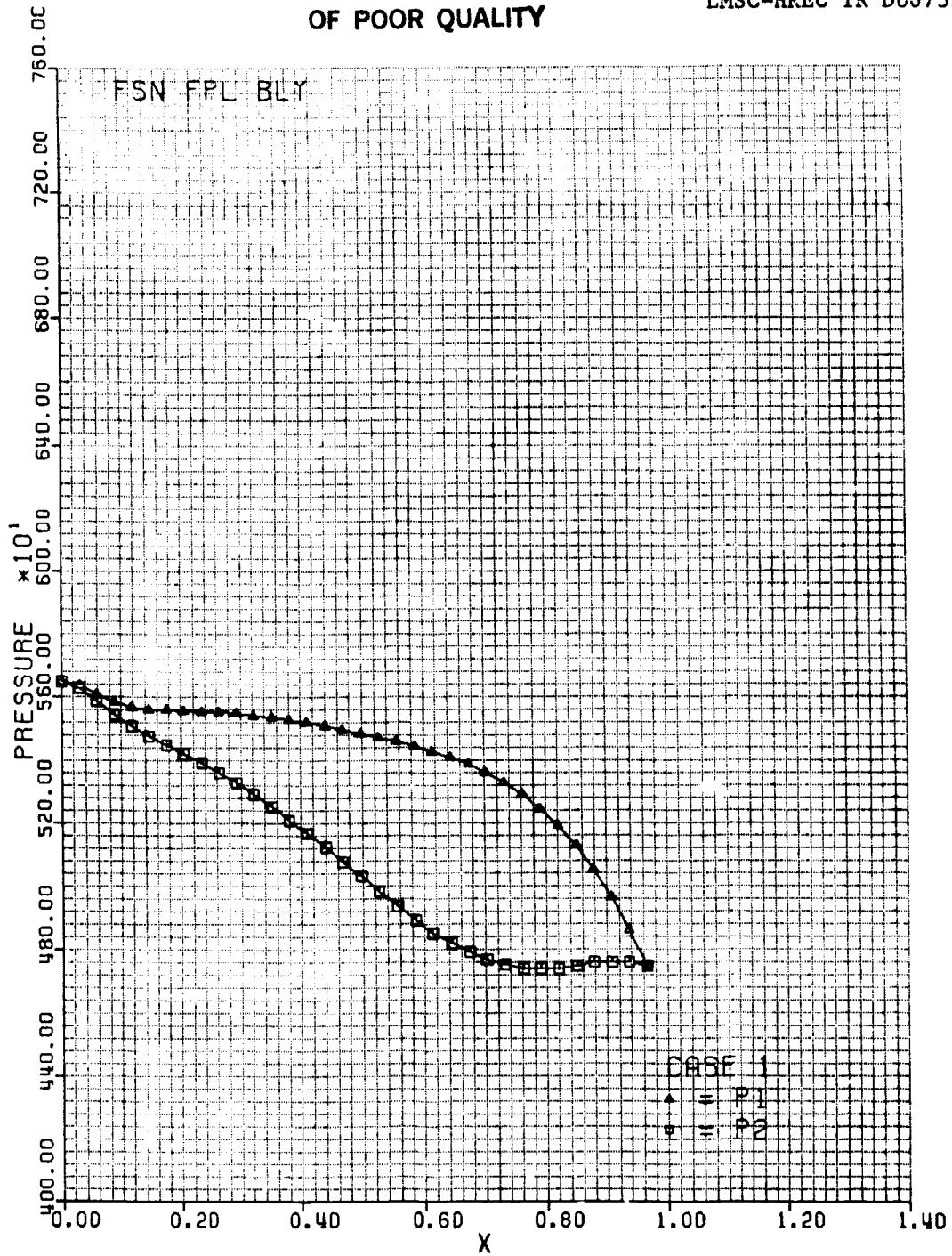

A.1.1

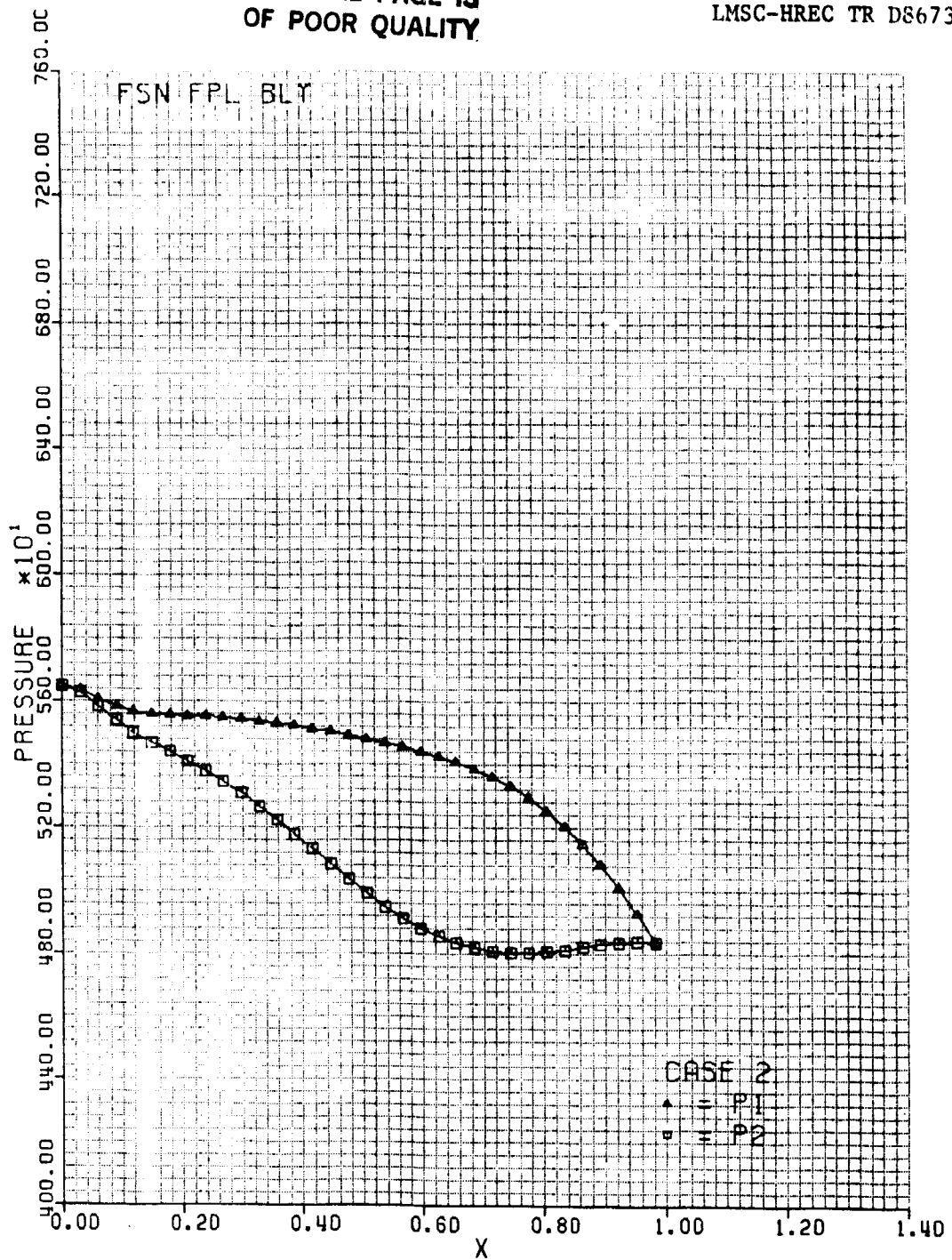

A.1.2

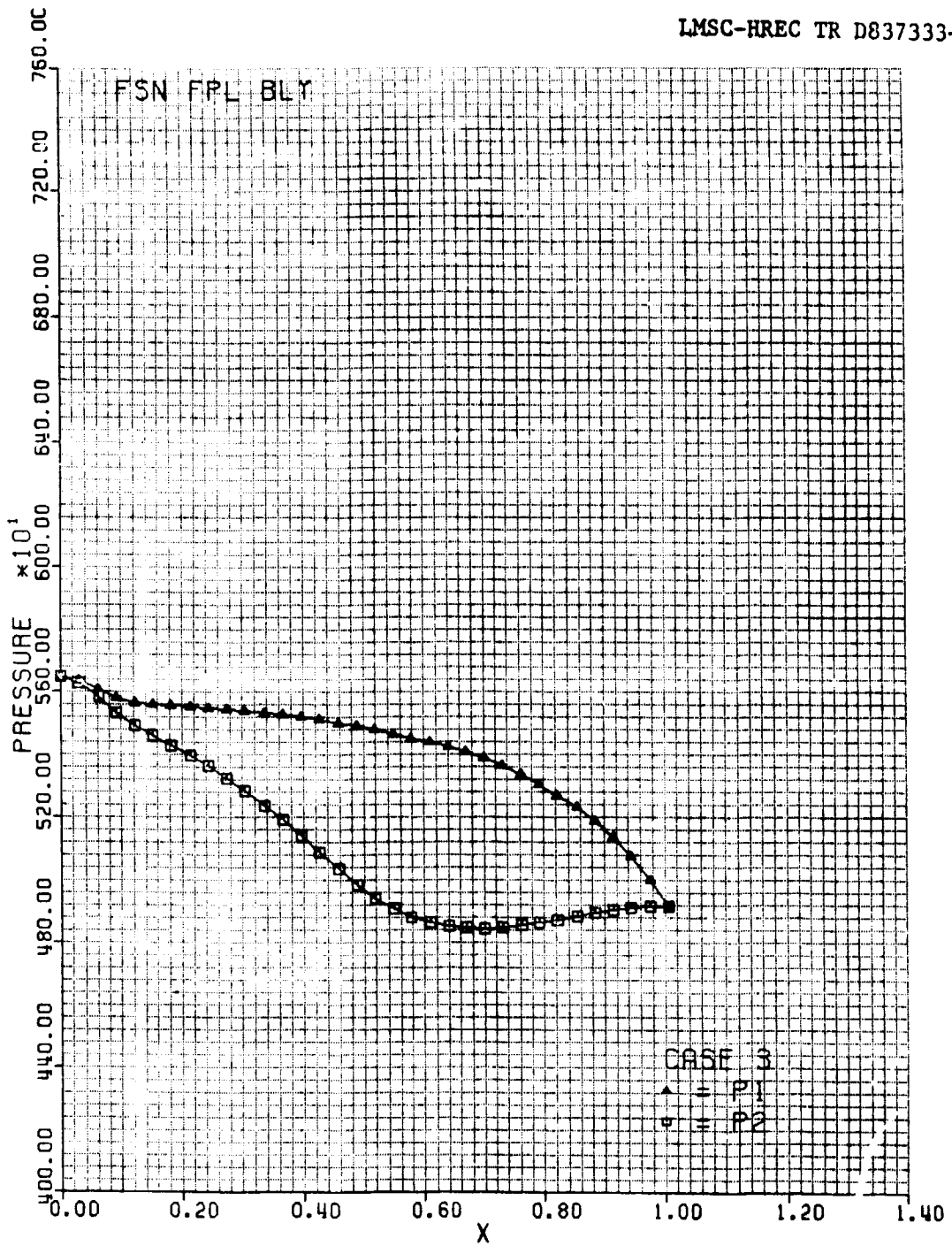

ORIGINAL PAGE IS
OF POOR QUALITY

A.1.3

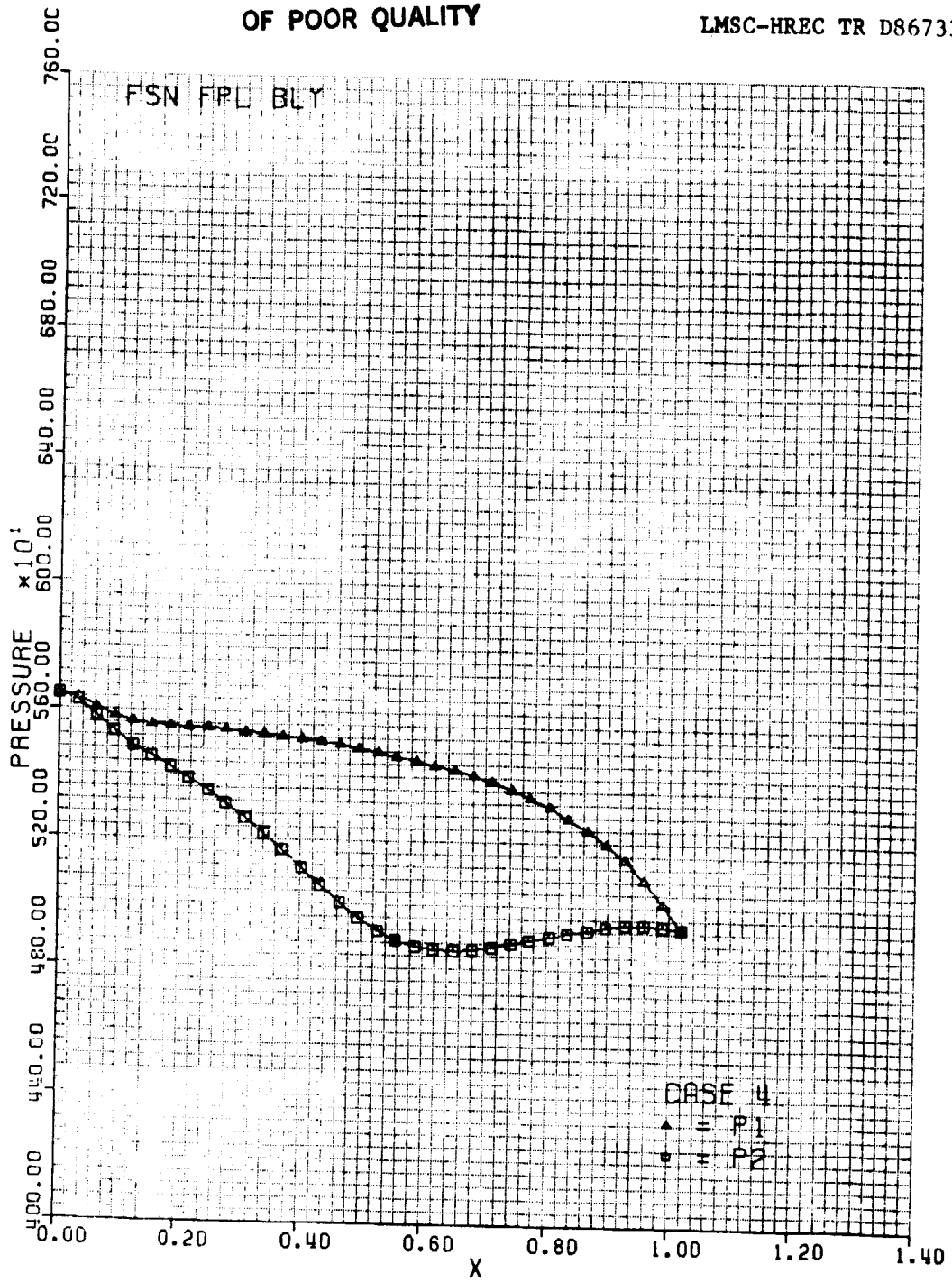

A.1.4

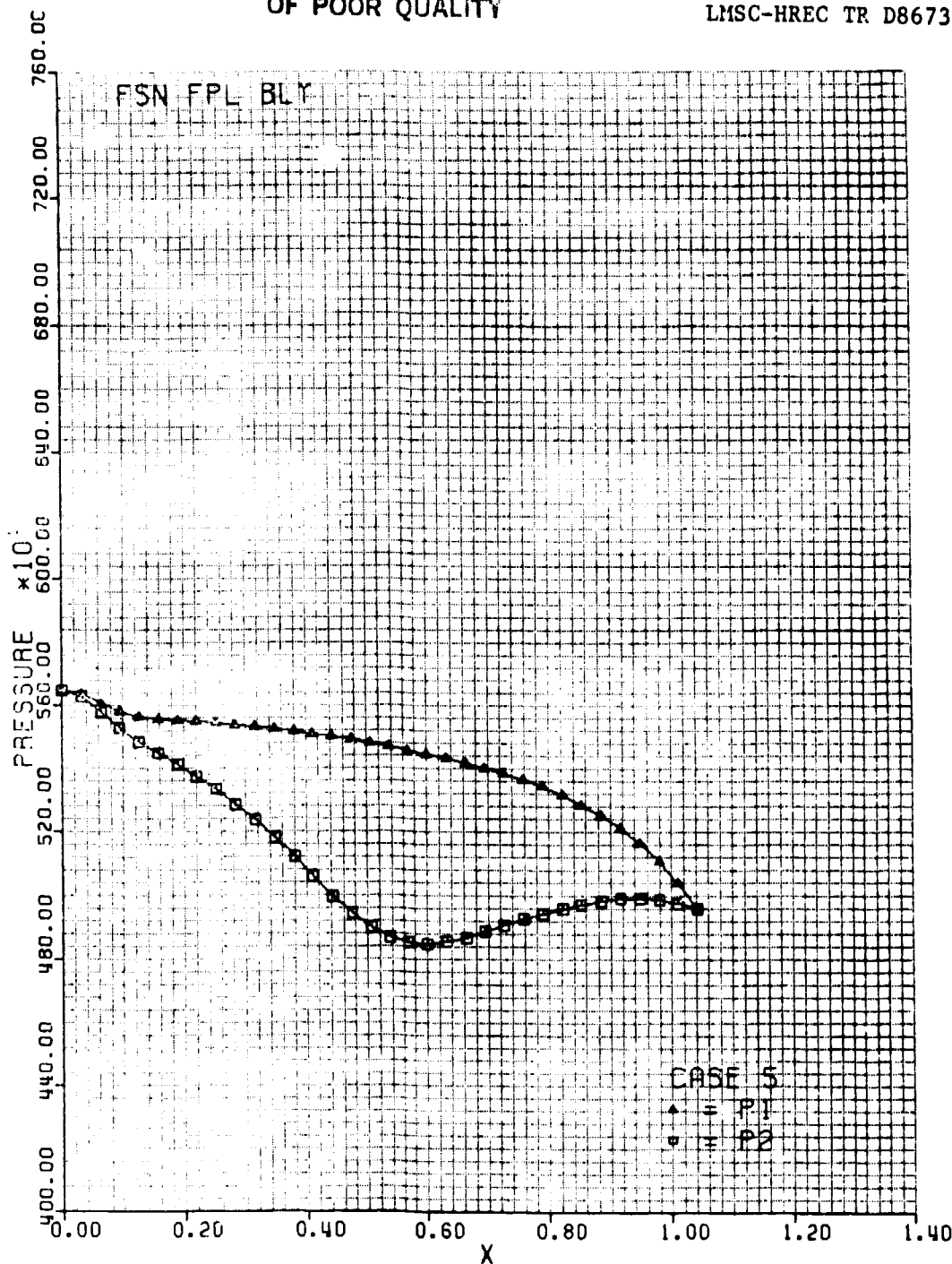

A.1.5

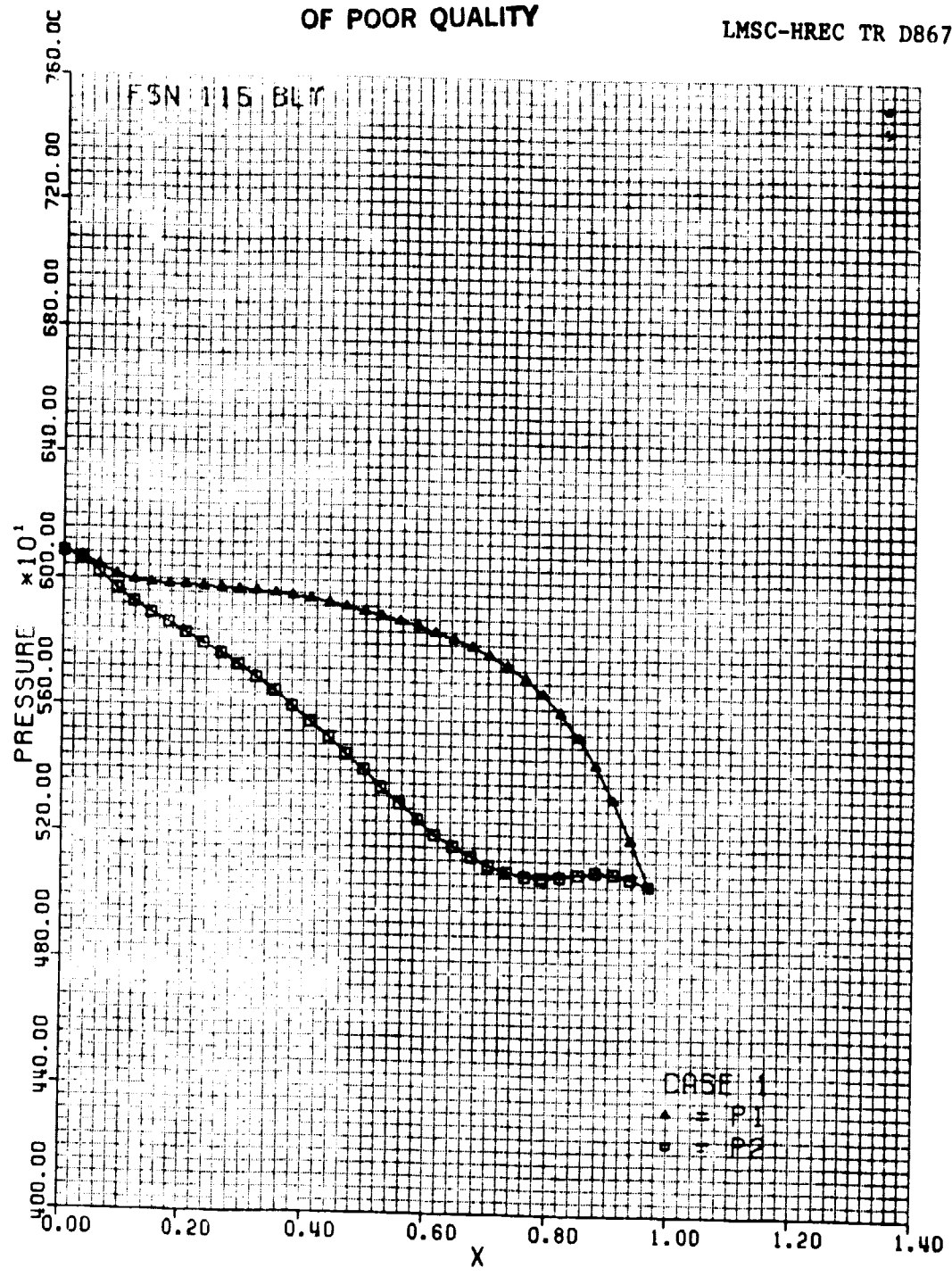

A.2.1

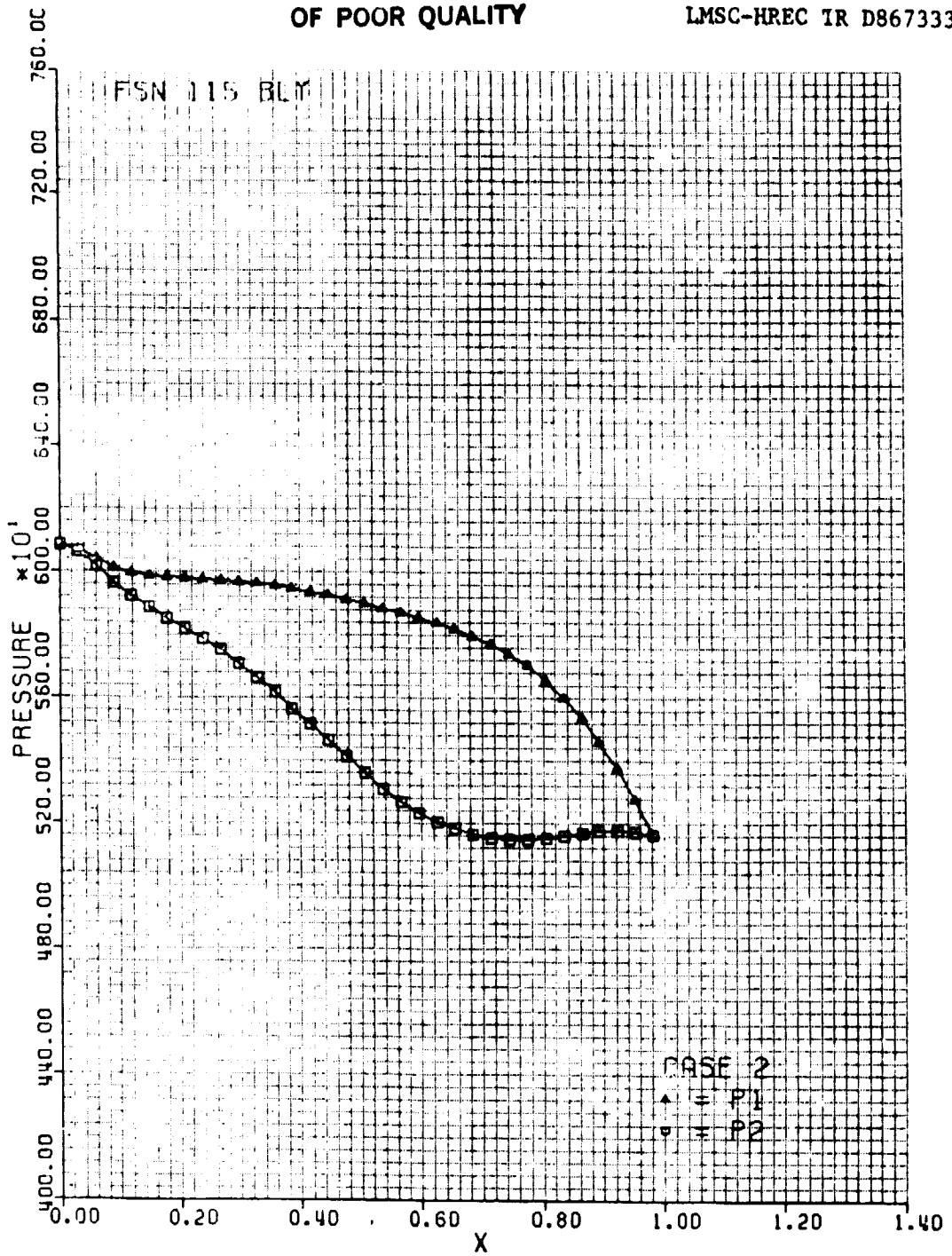

A.2.2

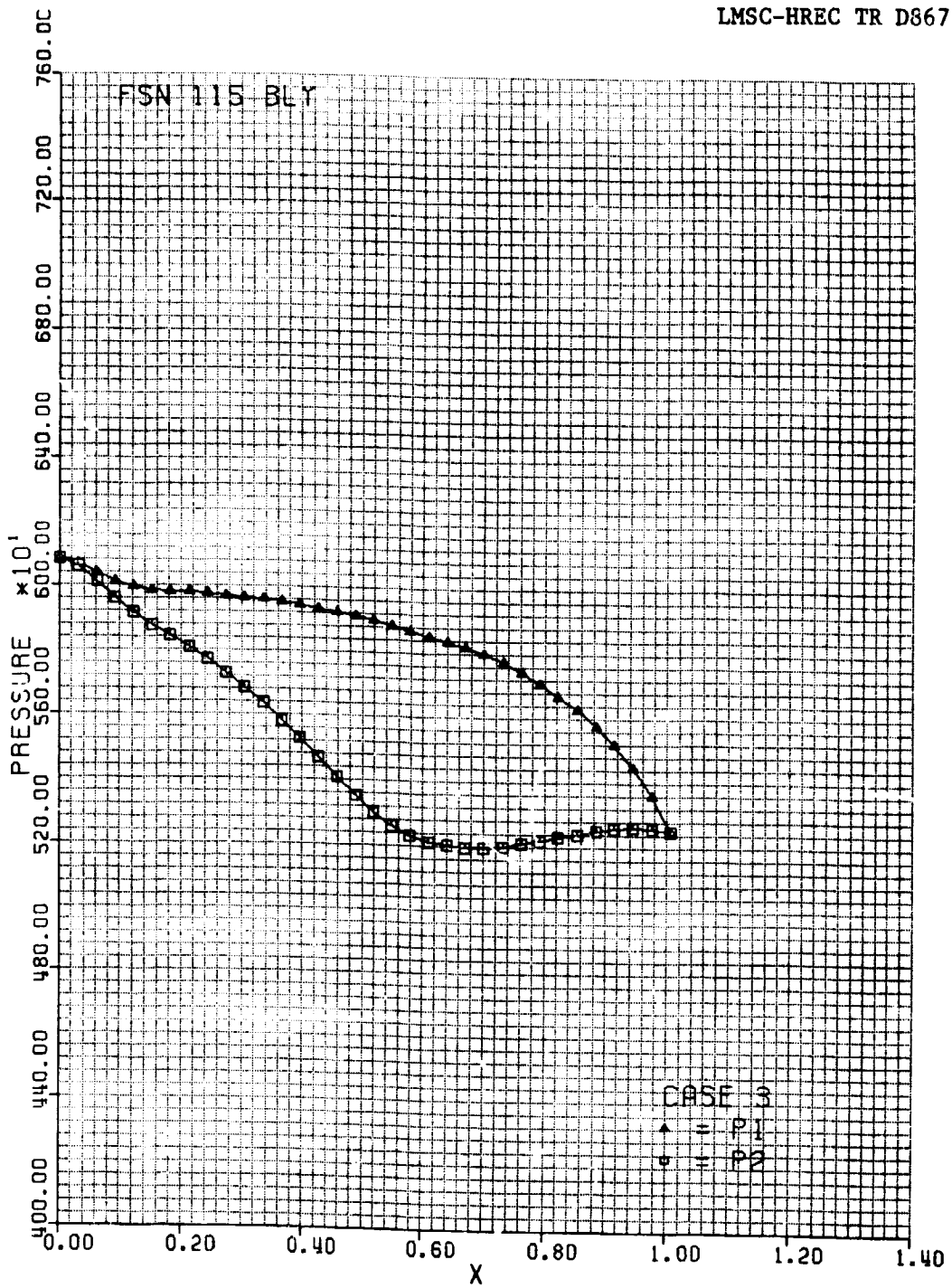

ORIGINAL PAGE IS
 OF POOR QUALITY

A.2.3

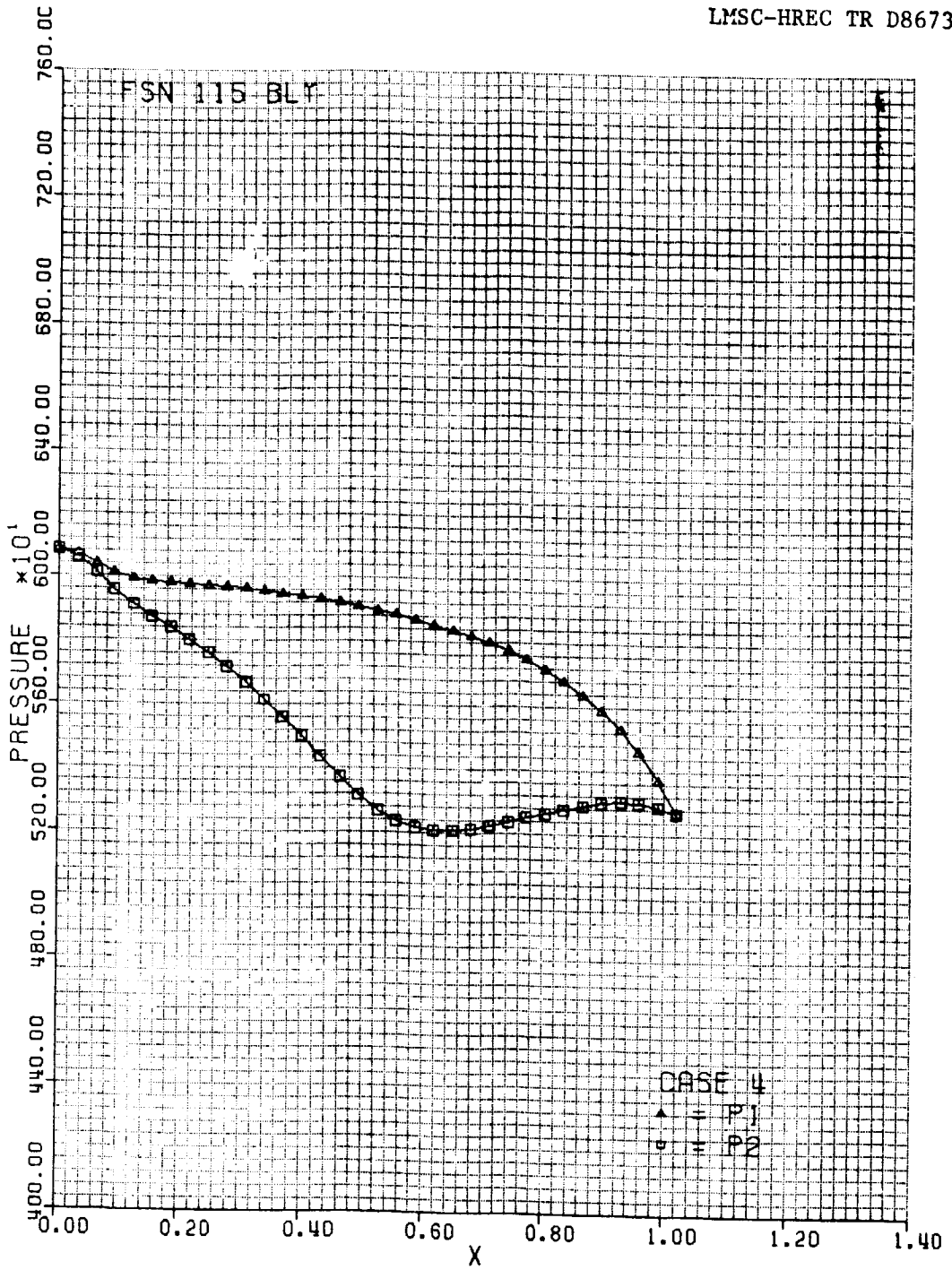

ORIGINAL PAGE 19
 OF POOR QUALITY

A.2.4

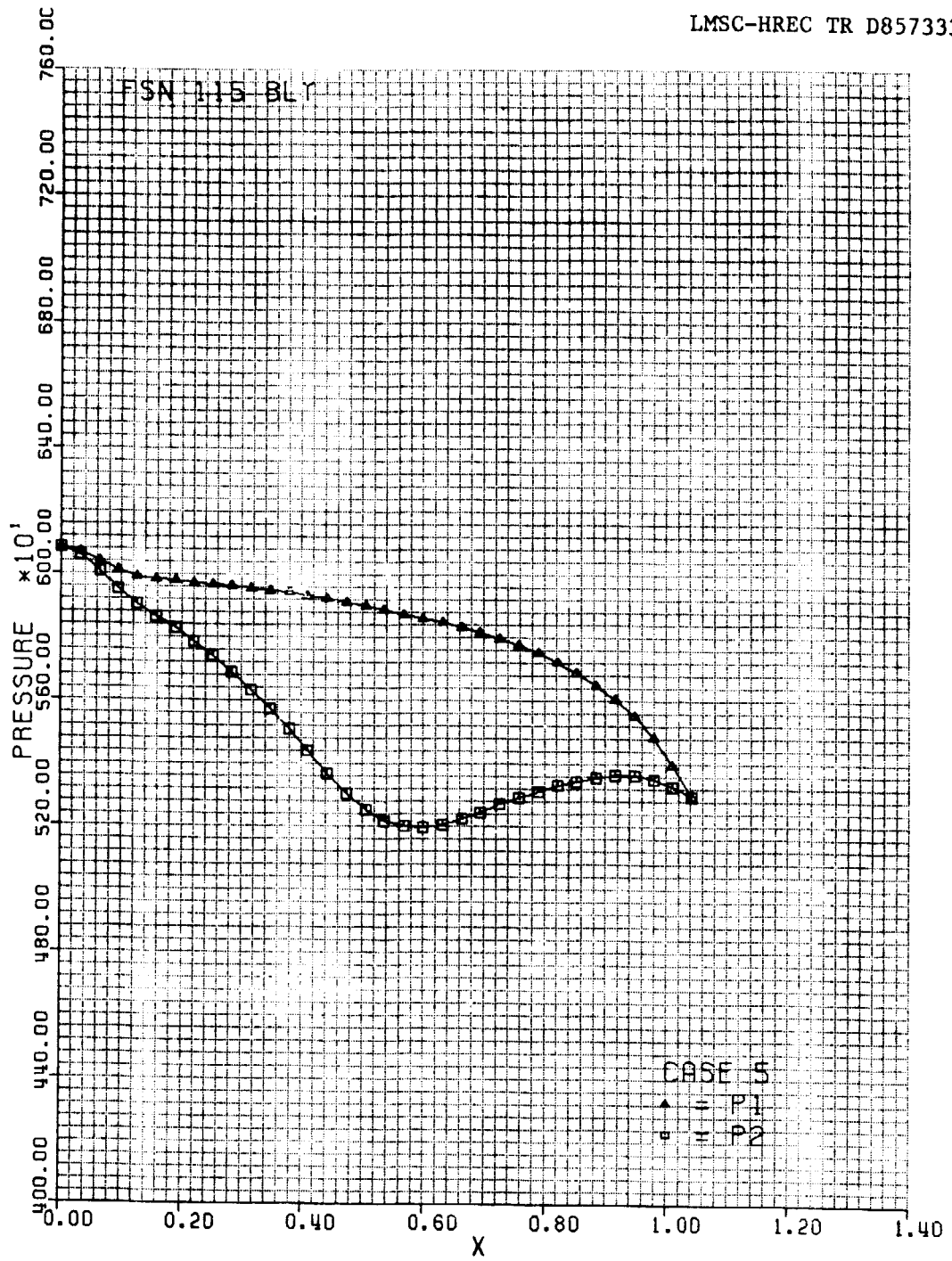

ORIGINAL PAGE IS
OF POOR QUALITY

A.2.5

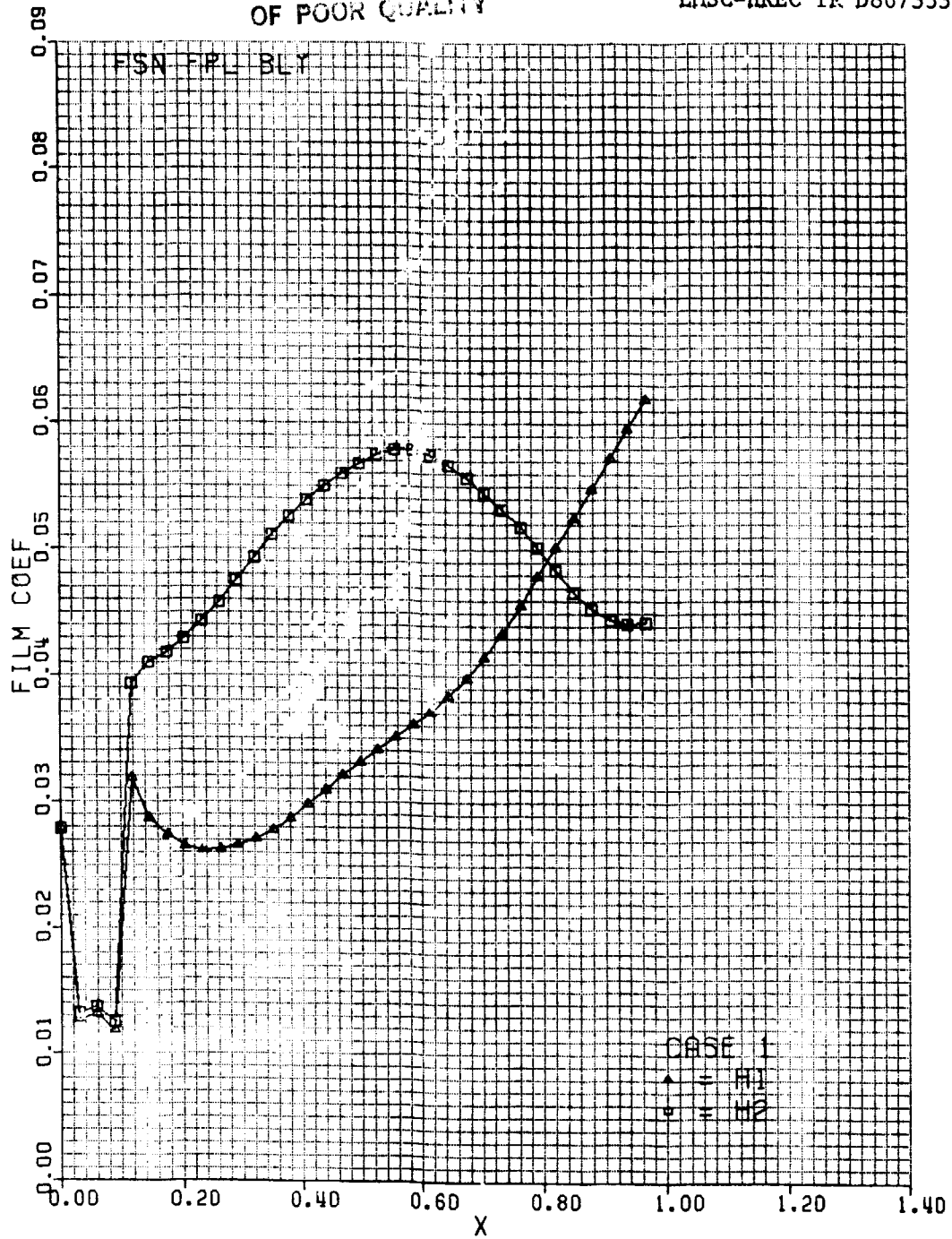

A.3.1

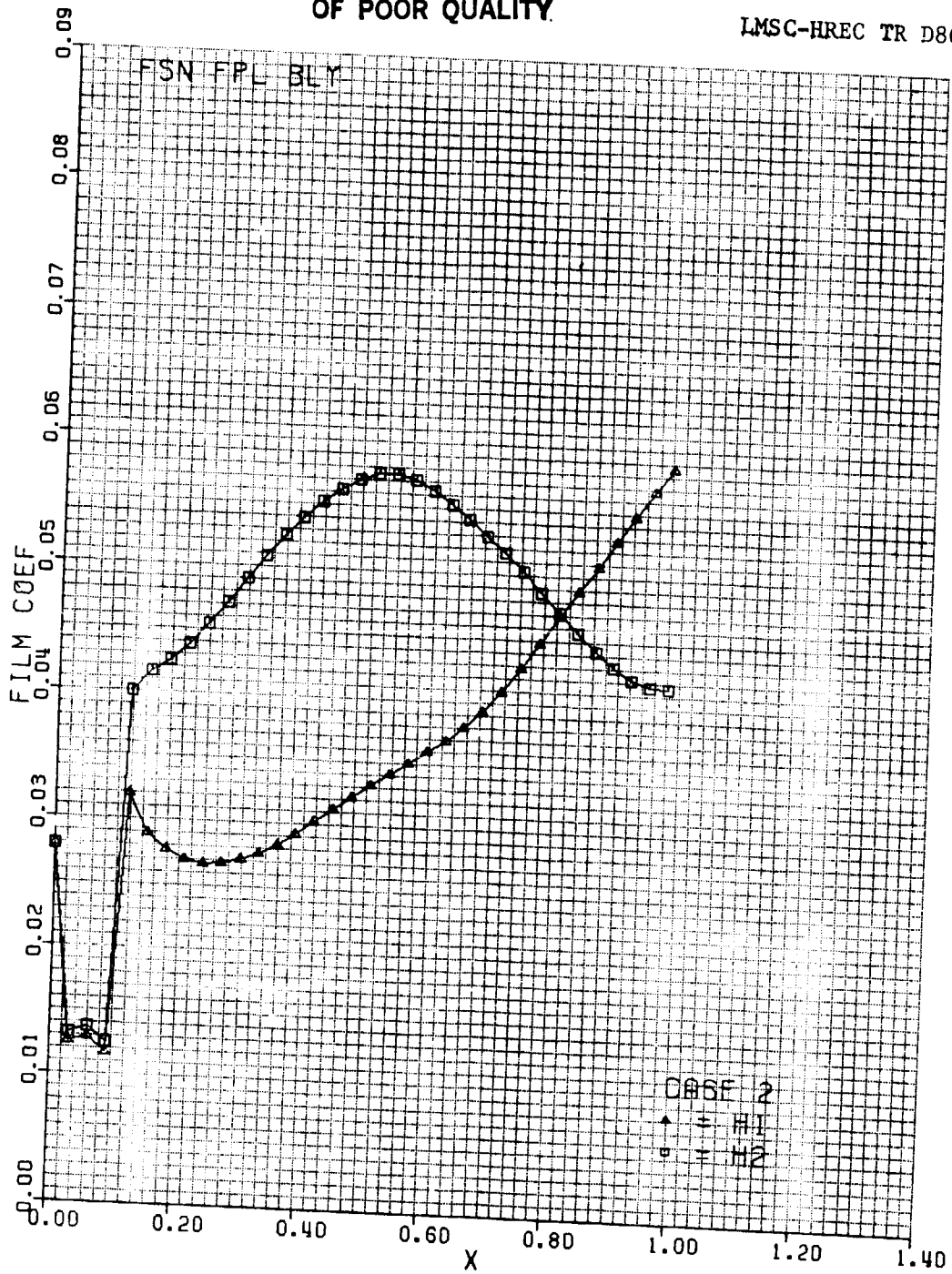

A.3.2

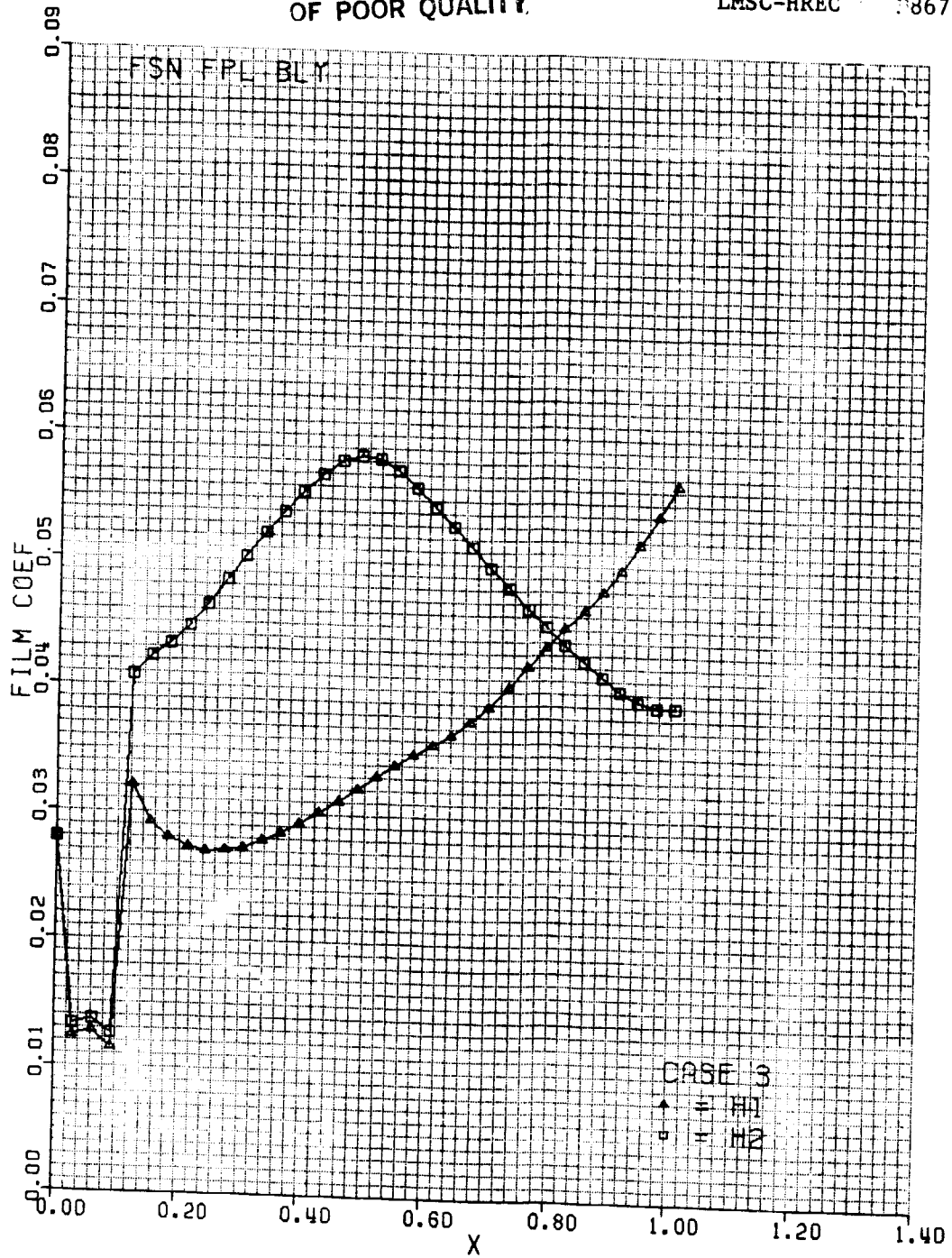

A.3.3

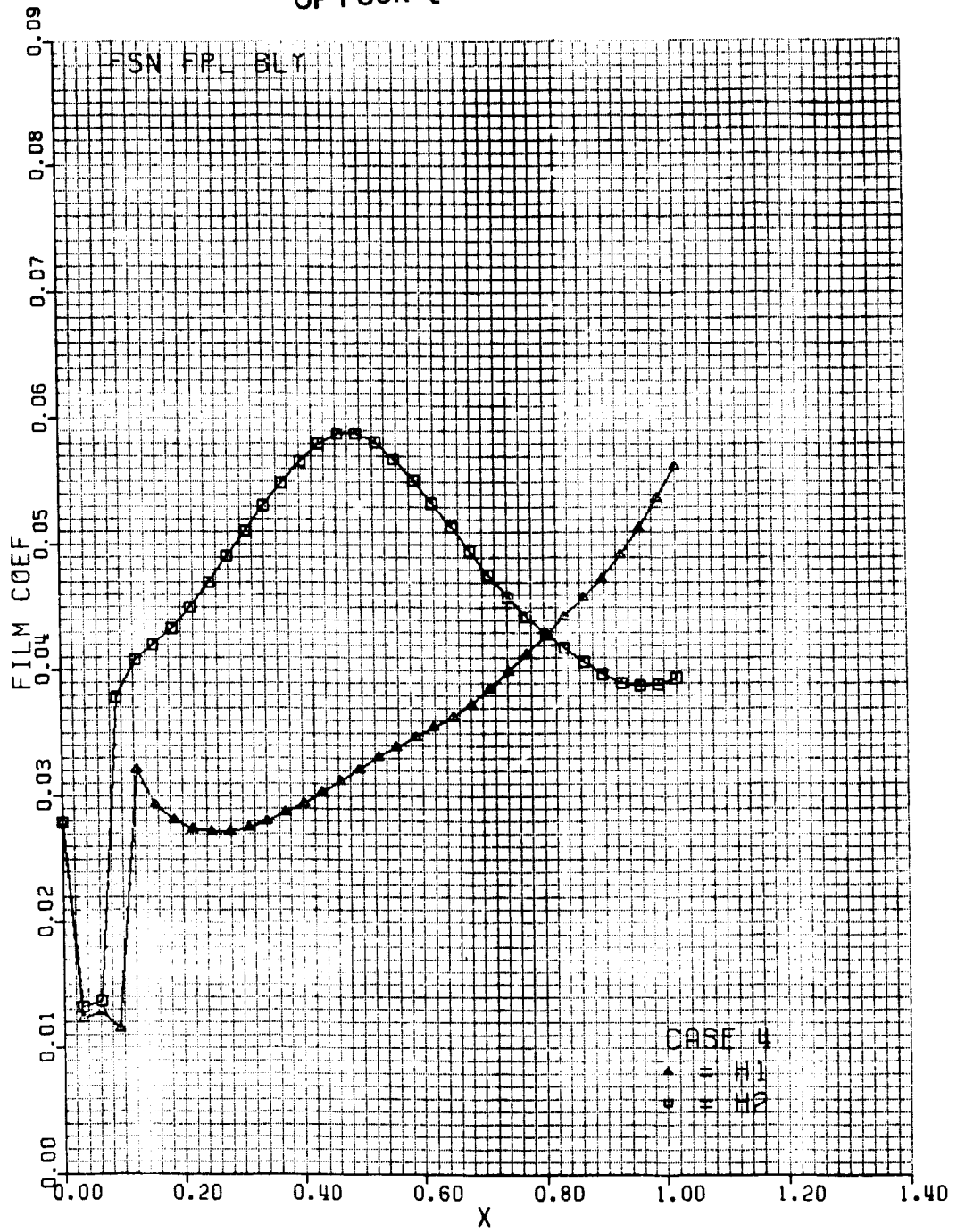

A.3.4

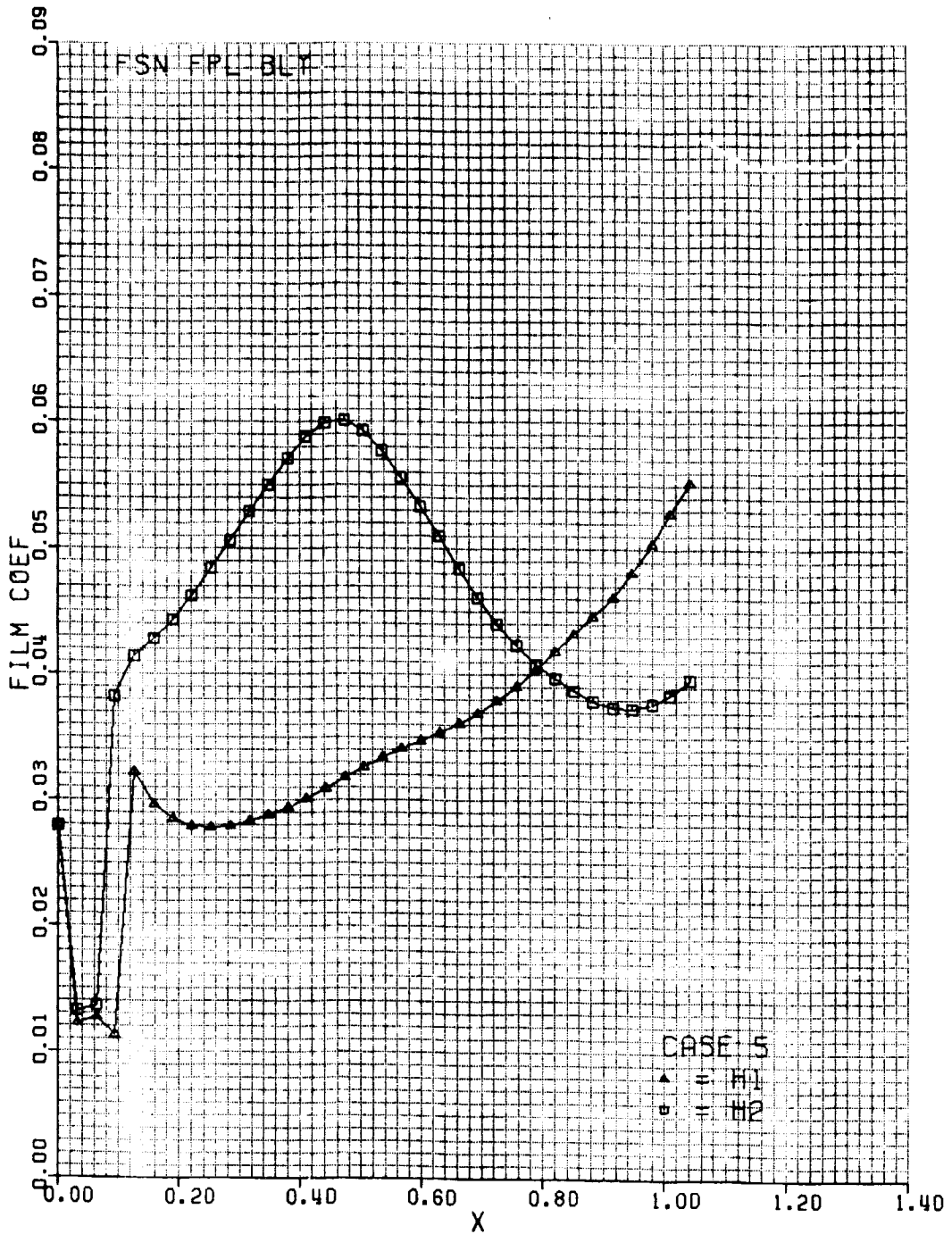

A.3.5

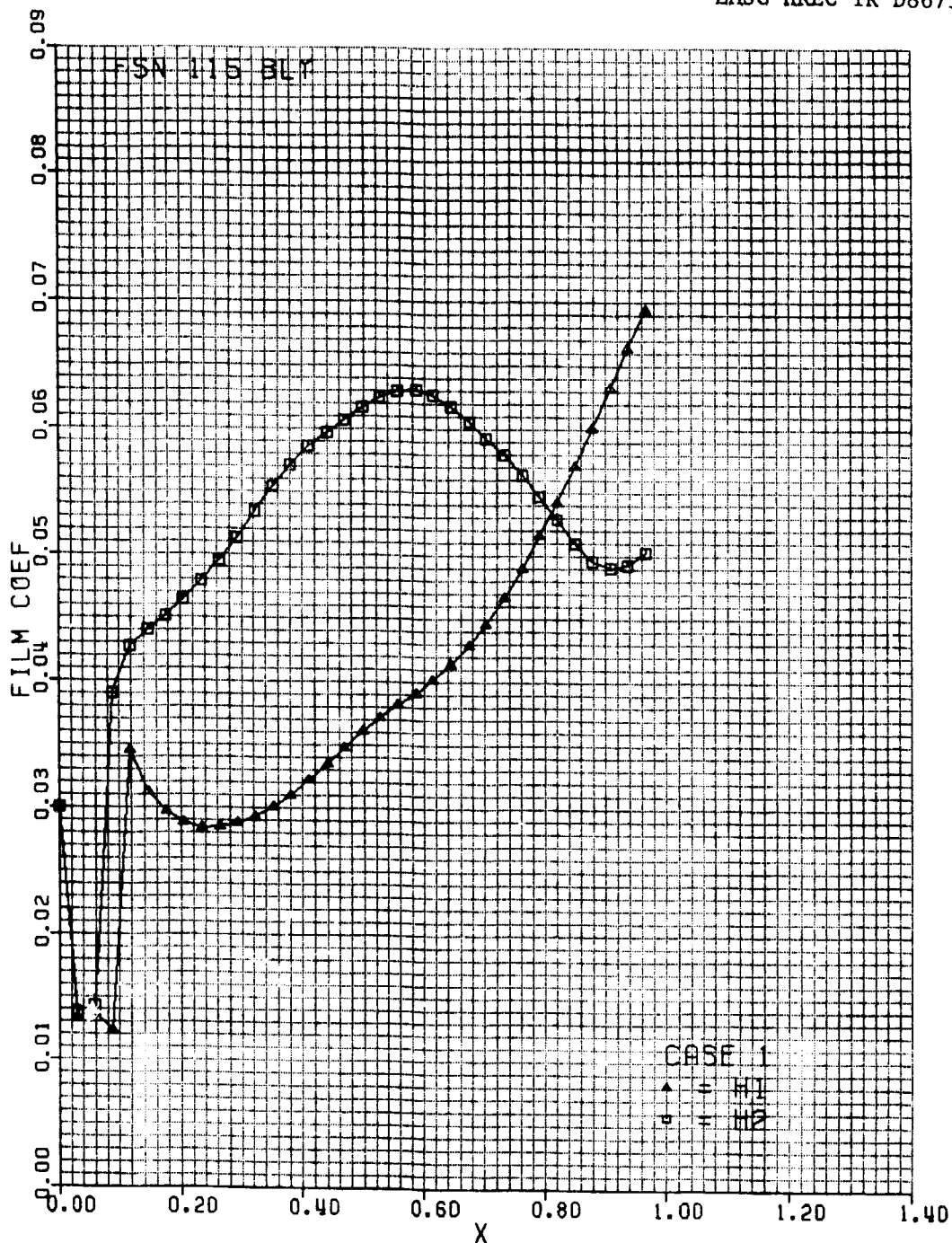

A.4.1

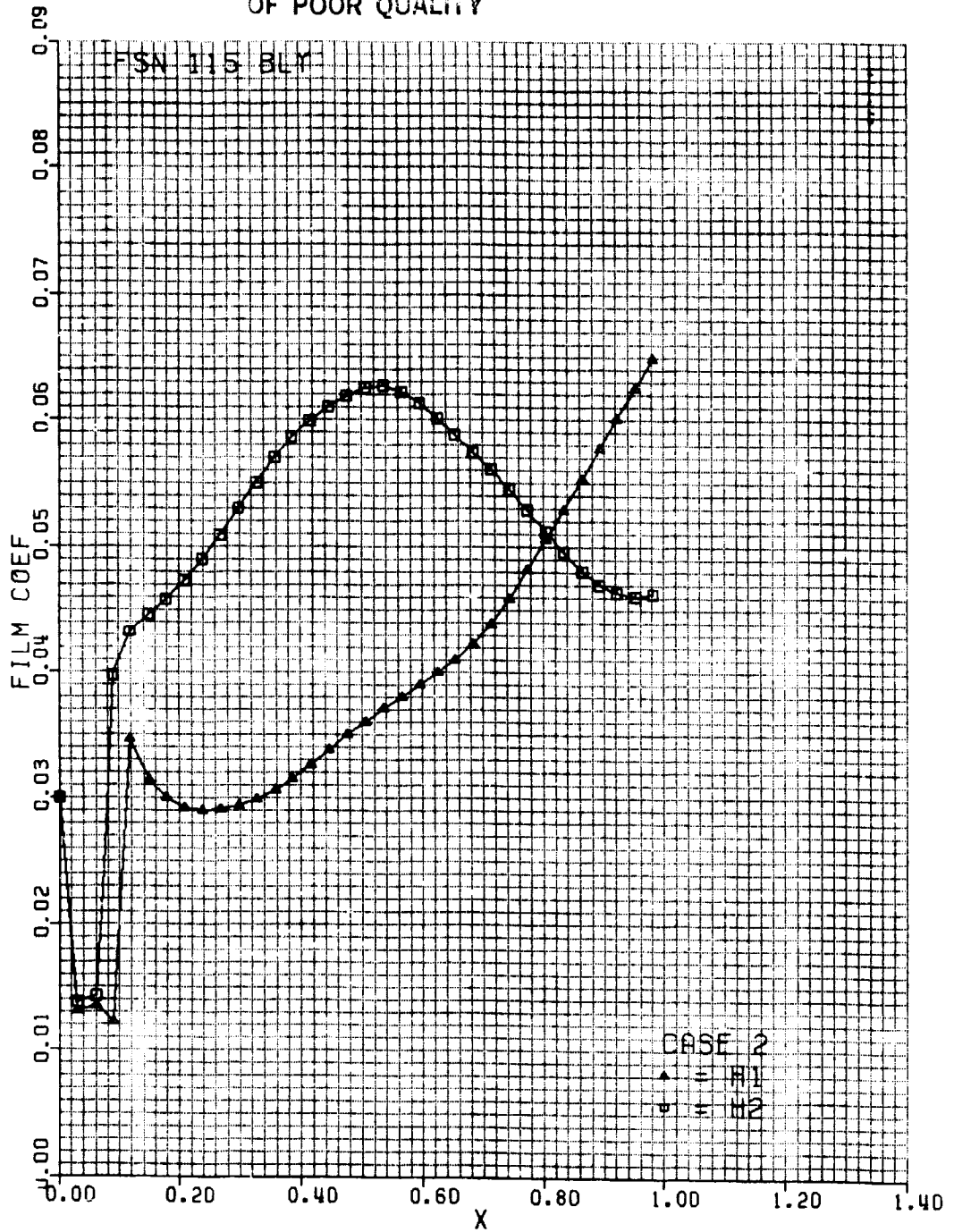

A.4.2

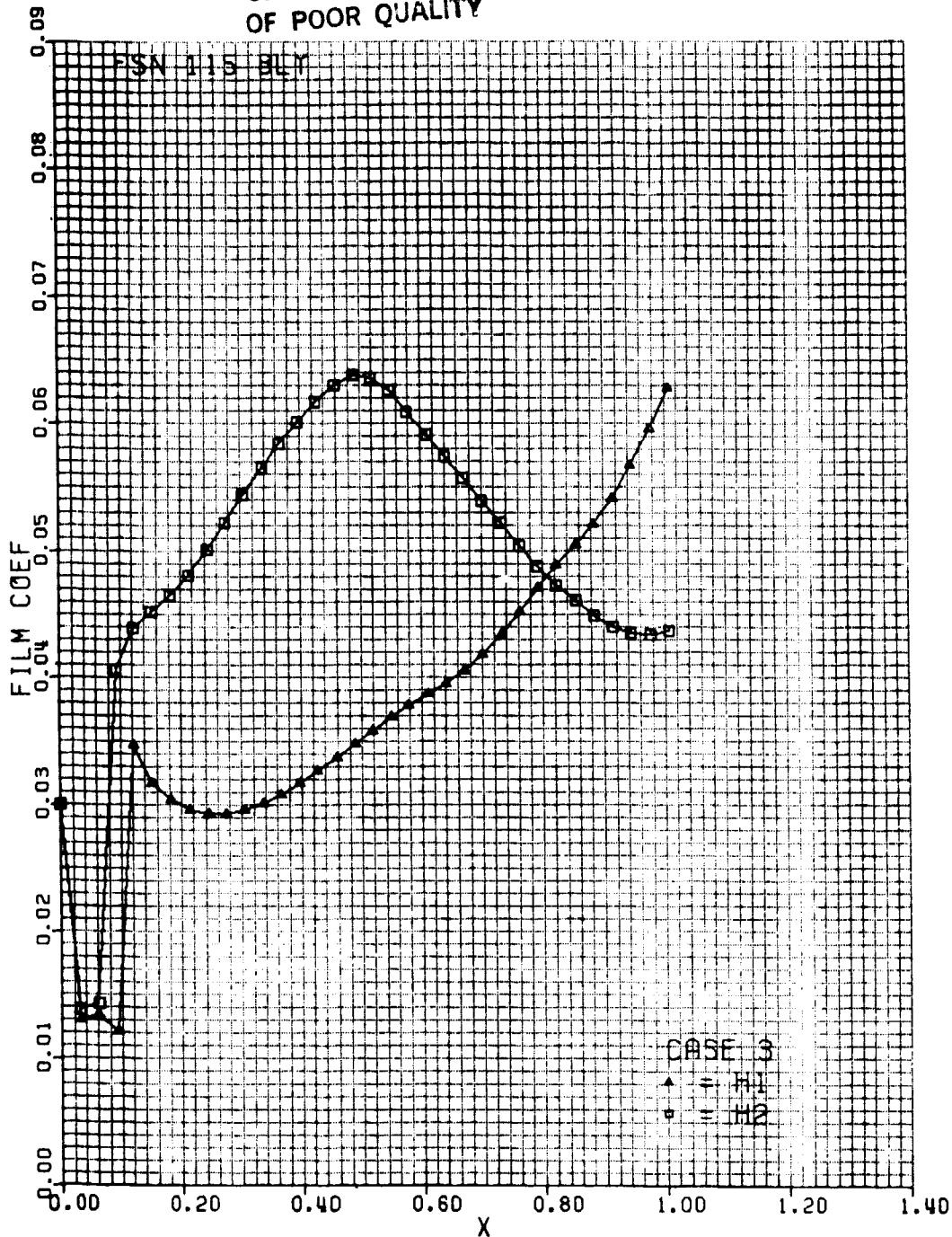

A.4.3

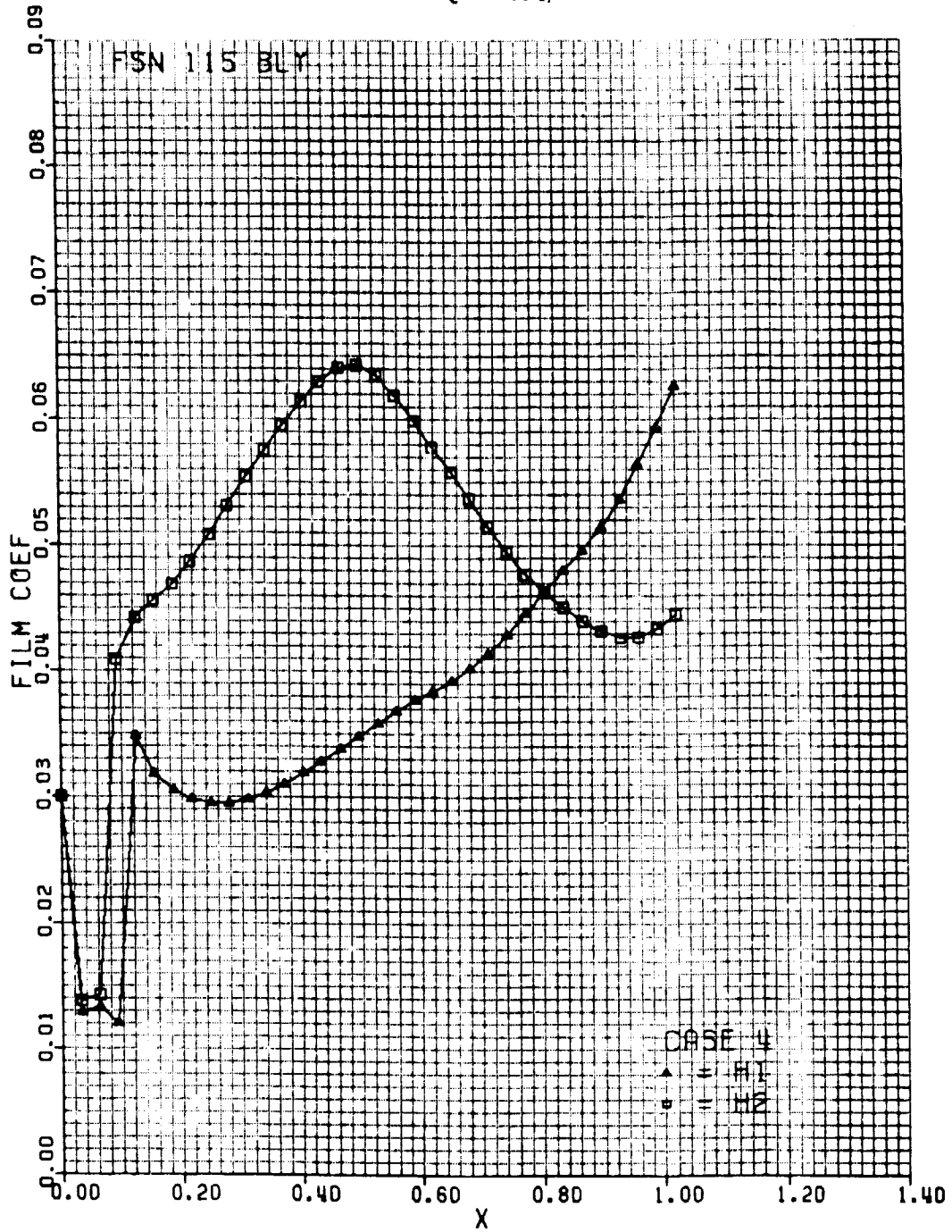

A.4.4

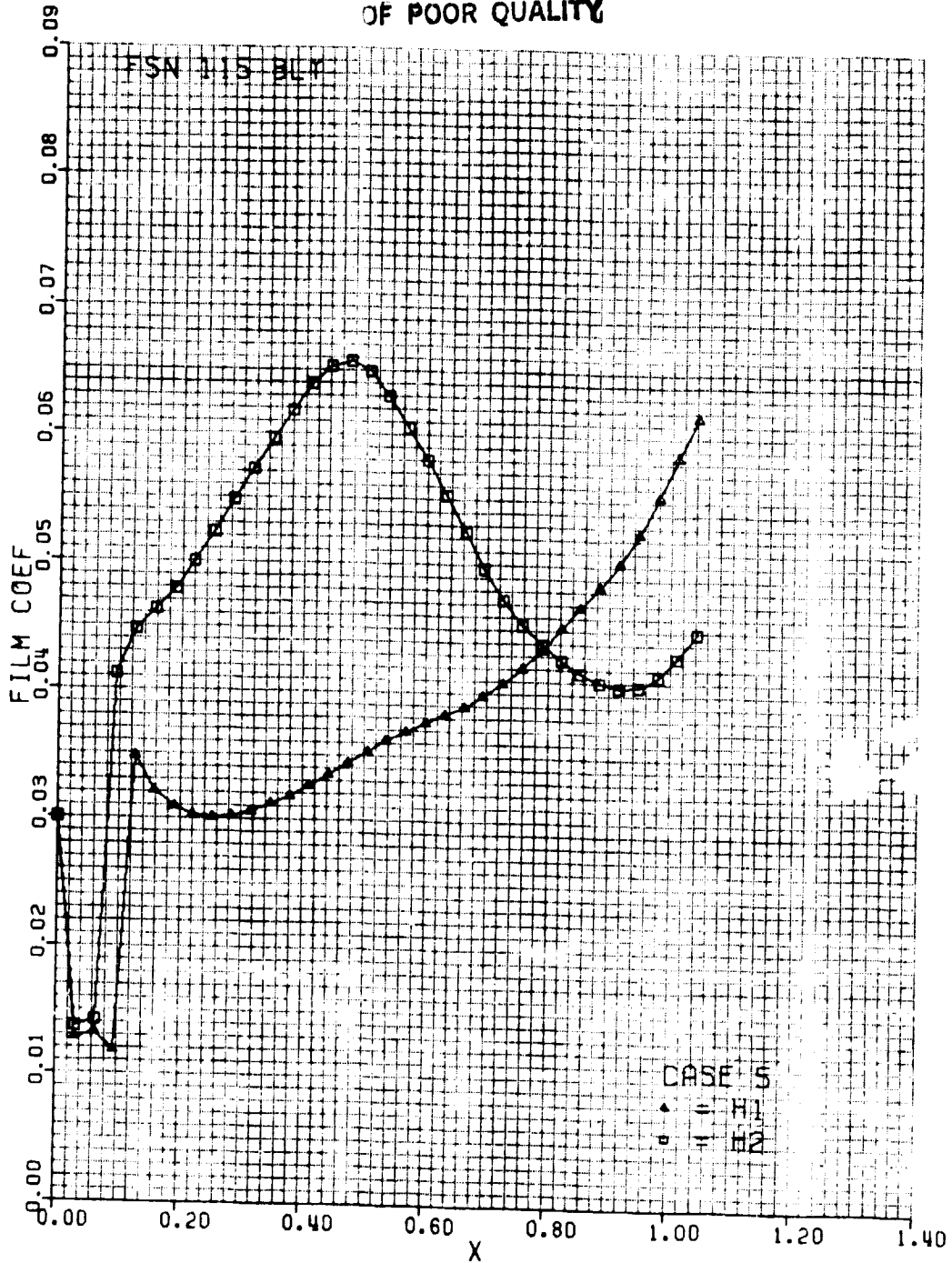

A.4.5

Appendix B

HPFTP FIRST STAGE BLADE PRESSURE, ADIABATIC WALL
TEMPERATURE AND HEAT TRANSFER
COEFFICIENT DISTRIBUTIONS

- B.1 FPL Pressure Distributions
- B.2 115 Percent Power Level Pressure Distributions
- B.3 FPL Heat Transfer Coefficients
- B.4 115 Percent Power Level Heat Transfer Coefficients

Surface 1 - Suction Surface Δ
Surface 2 - Pressure Surface \square

Approximate Adiabatic Wall
Temperatures (F)

	FPL	115 Percent
Case 1 - R = 4.6438 Hub	1475	1420
Case 2 - R = 4.83 Intermediate	↓	↓
Case 3 - R = 5.0797 Mean	↓	↓
Case 4 - R = 5.27 Intermediate	↓	↓
Case 5 - R = 5.5156 Tip	↓	↓

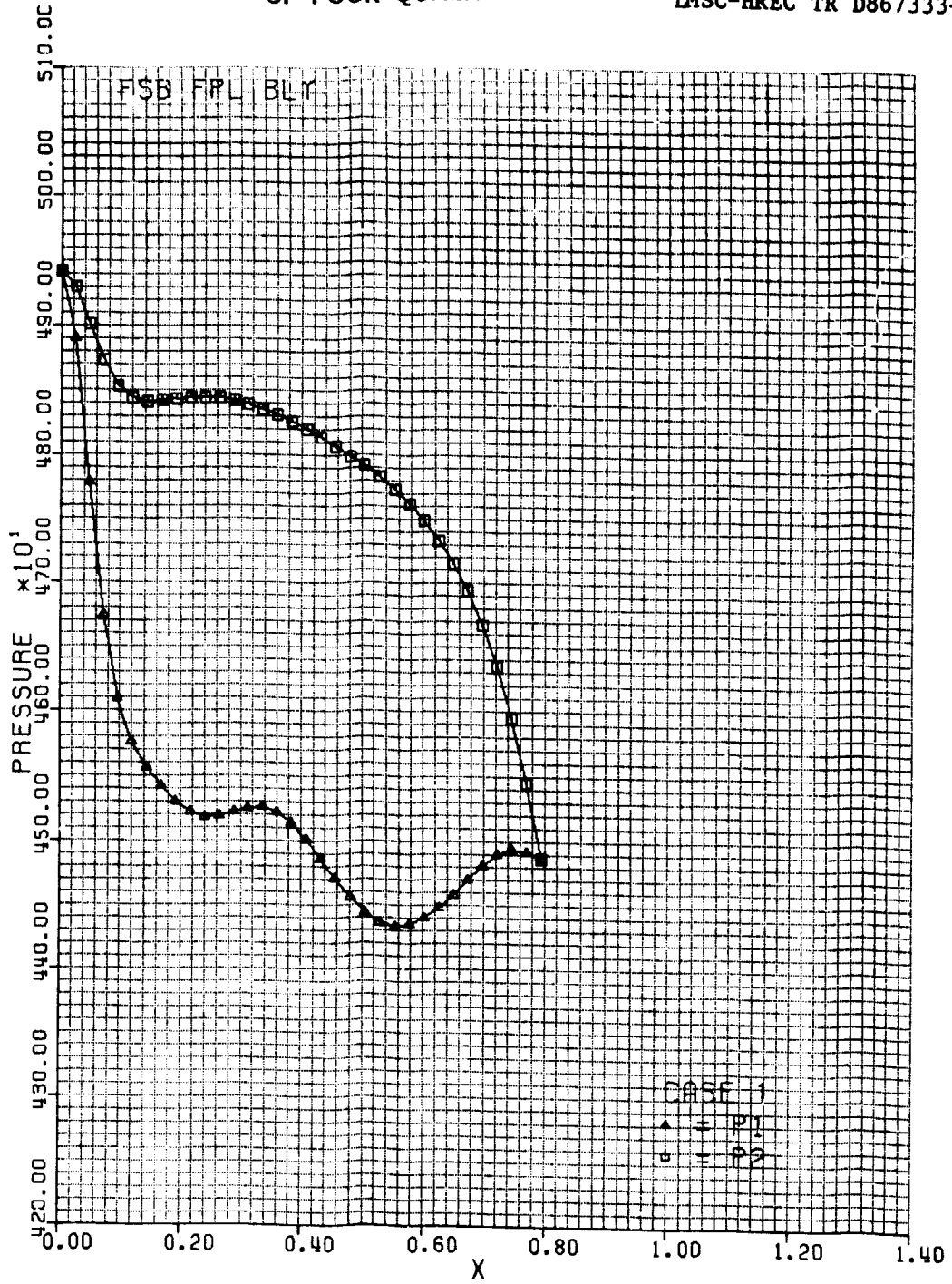

B.1.1

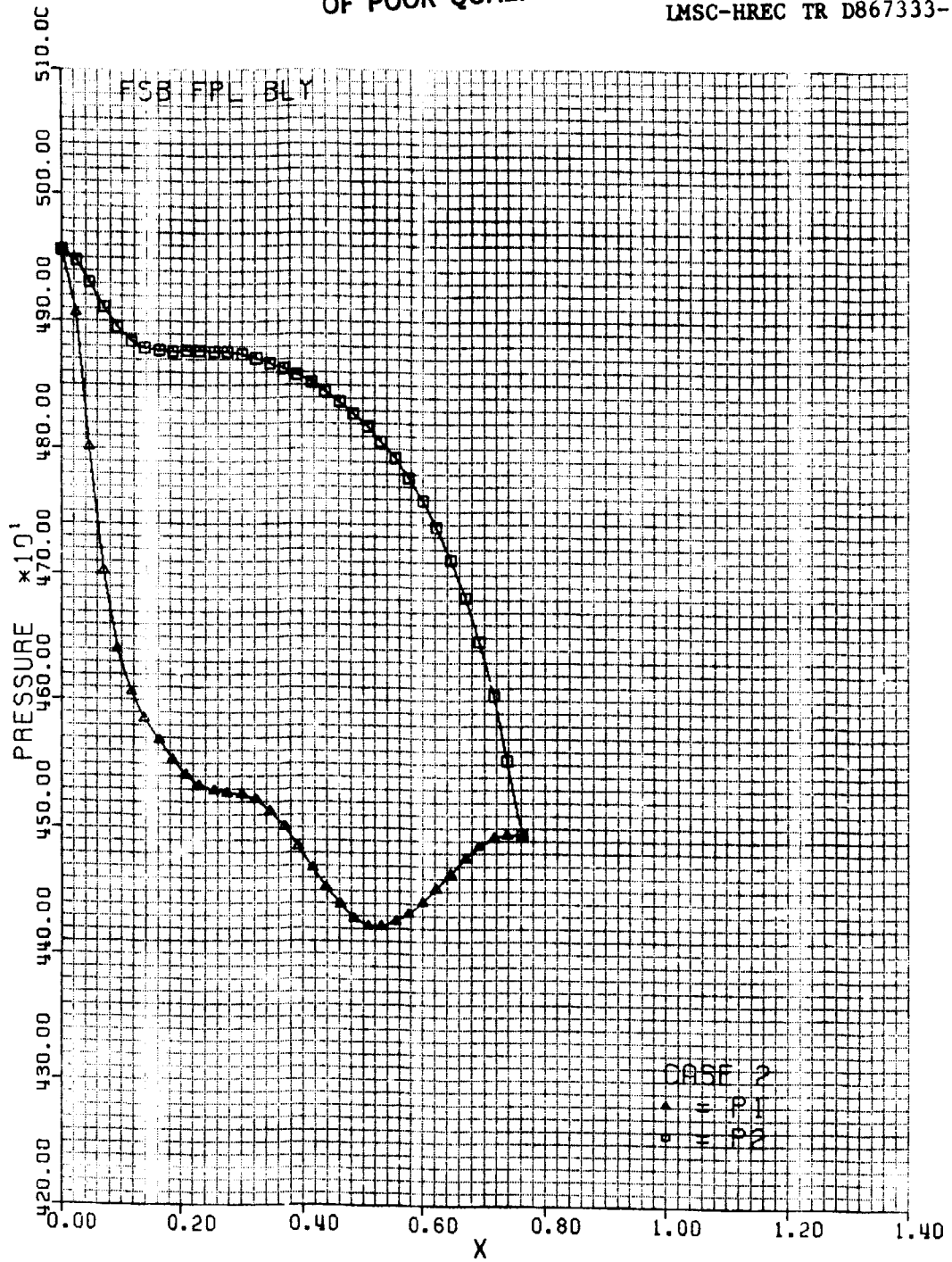

B.1.2

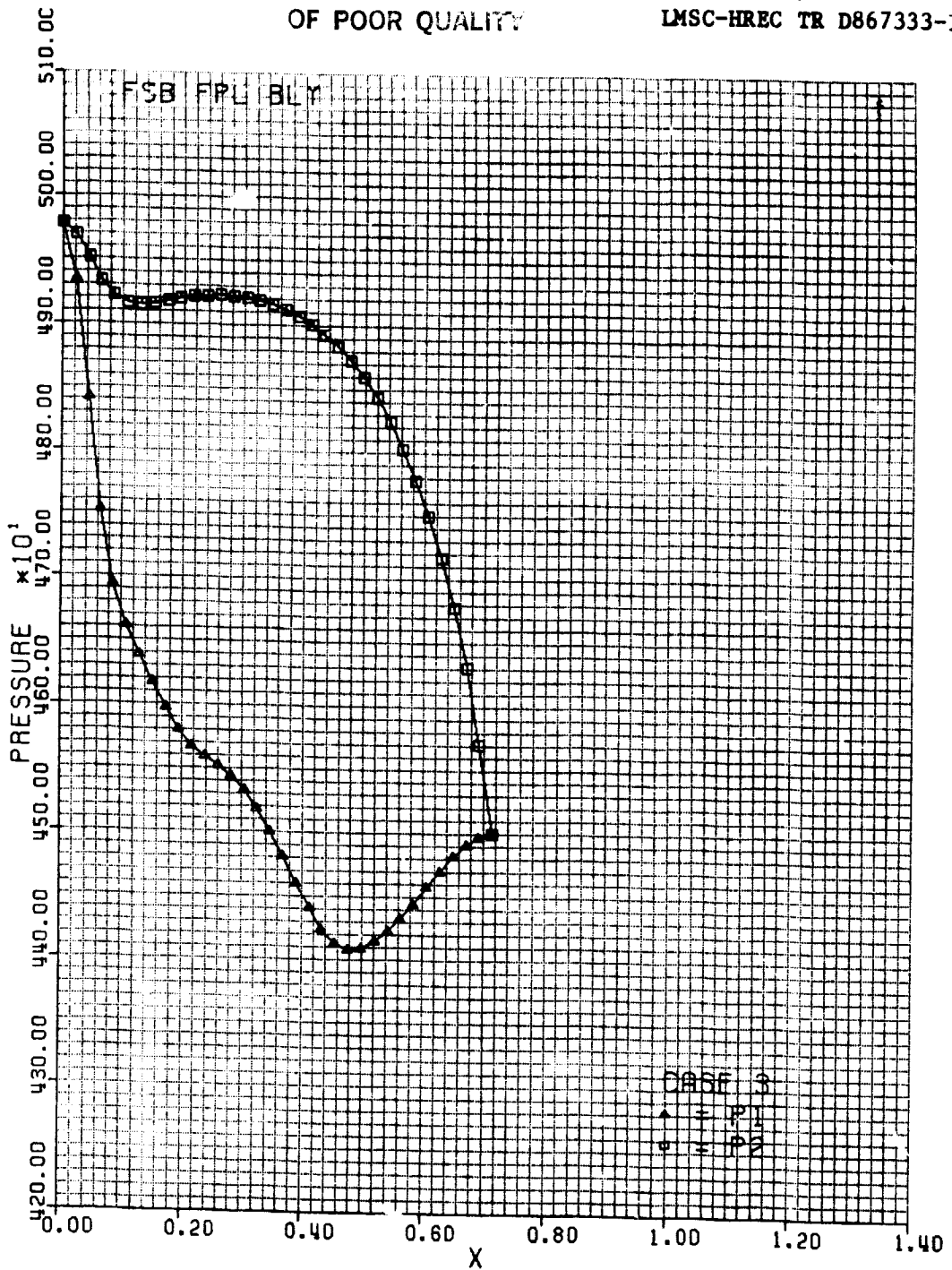

B.1.3

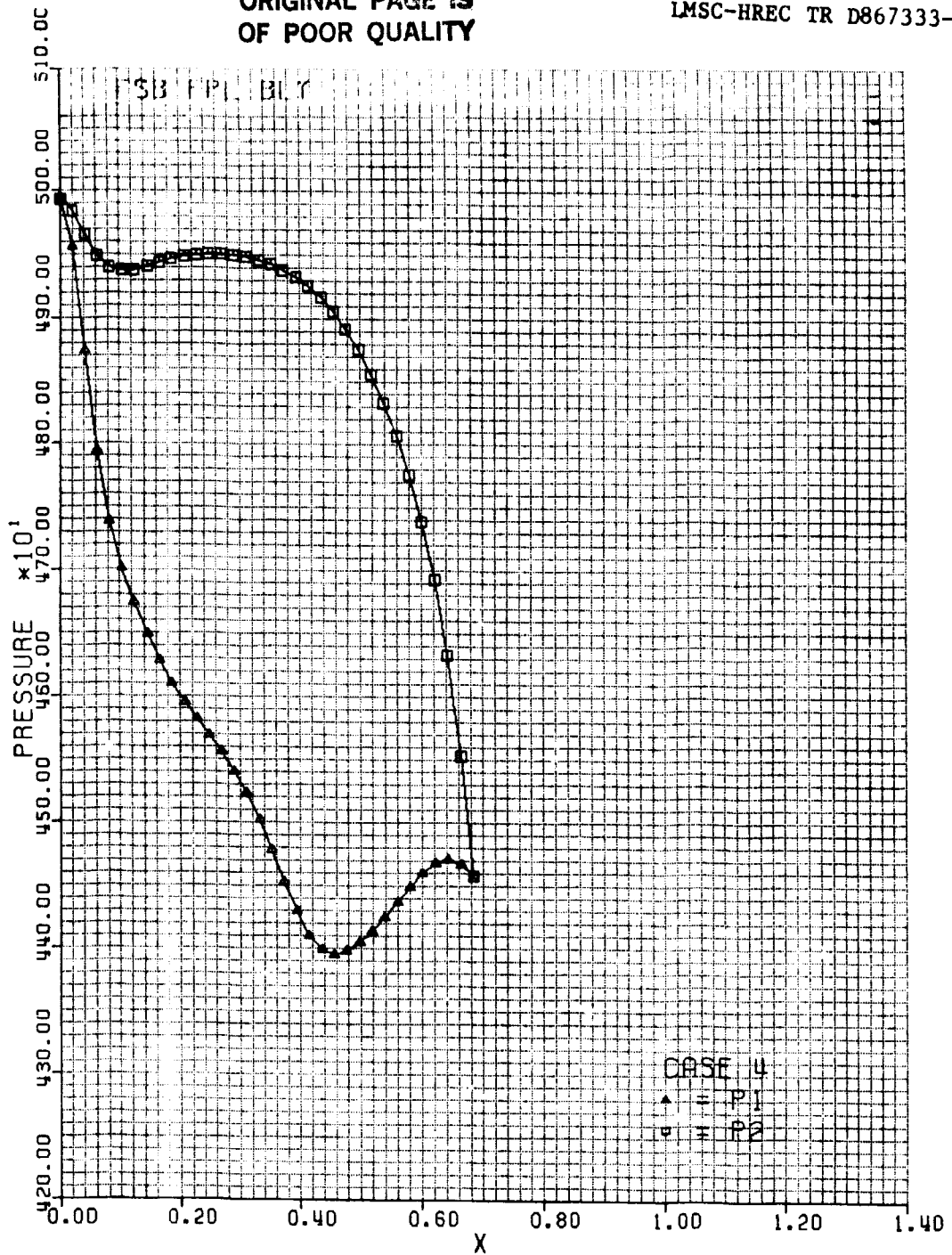

B.1.4

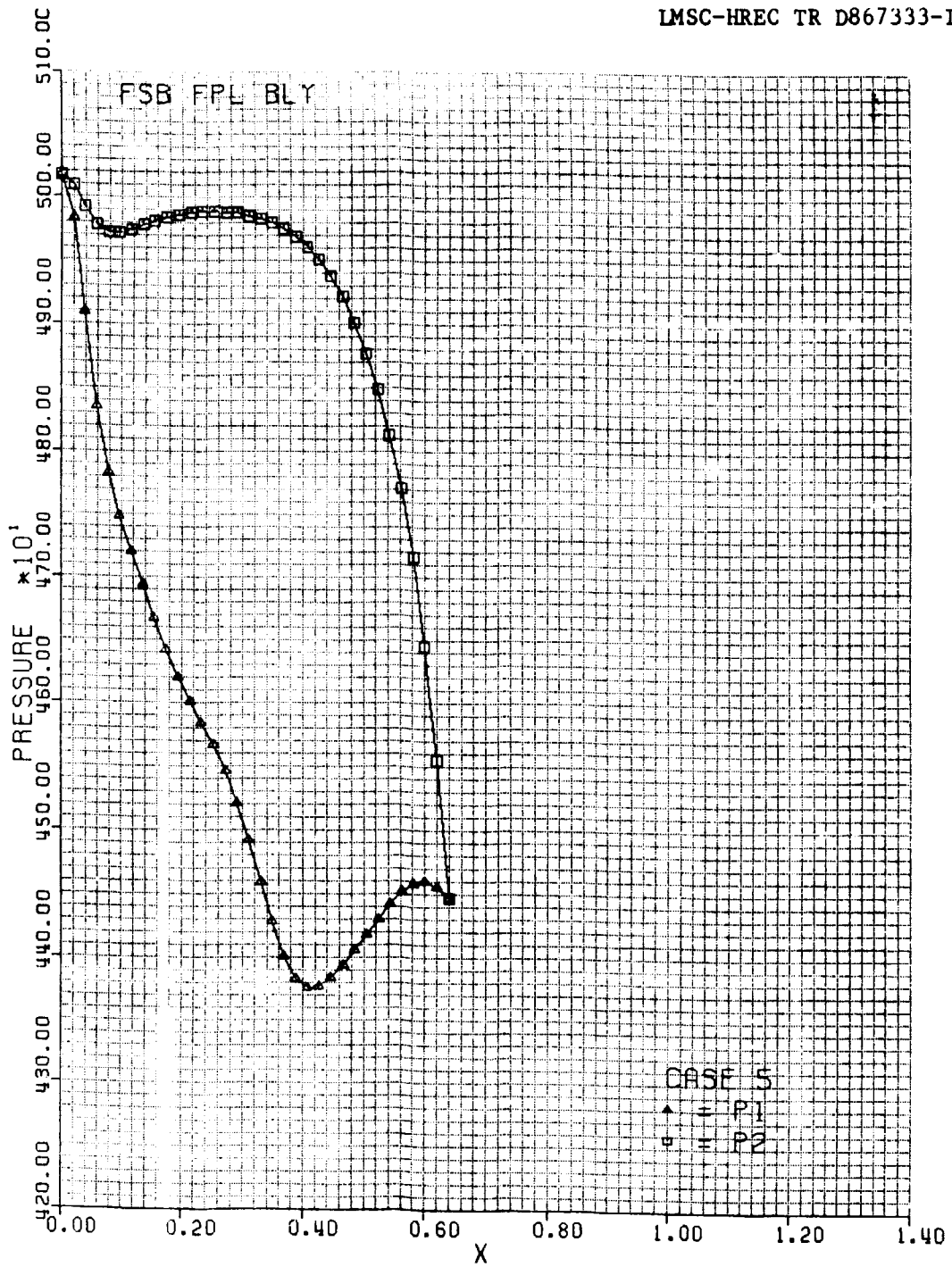

ORIGINAL PAGE IS
OF POOR QUALITY

B.1.5

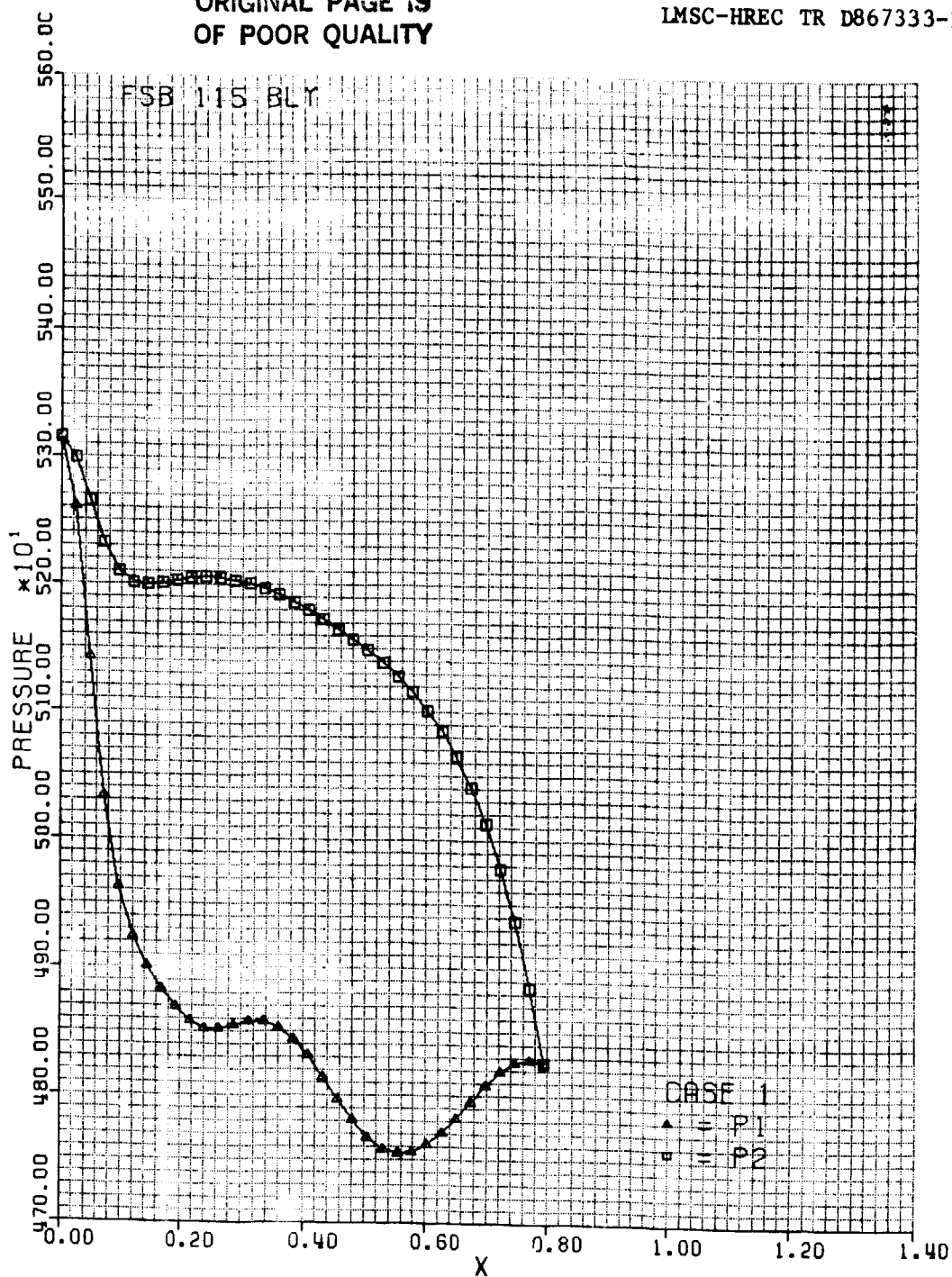

B.2.1

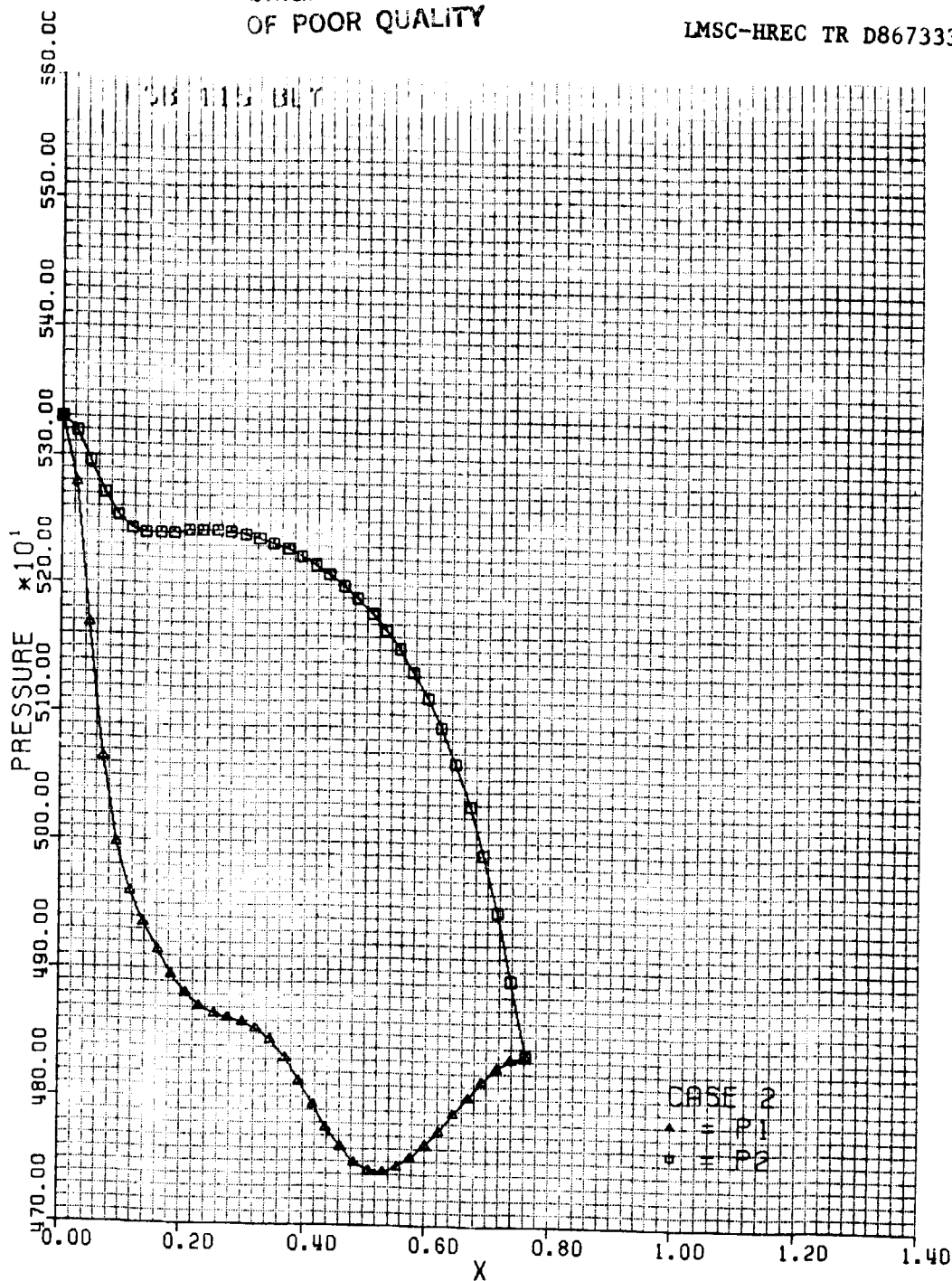

B.2.2

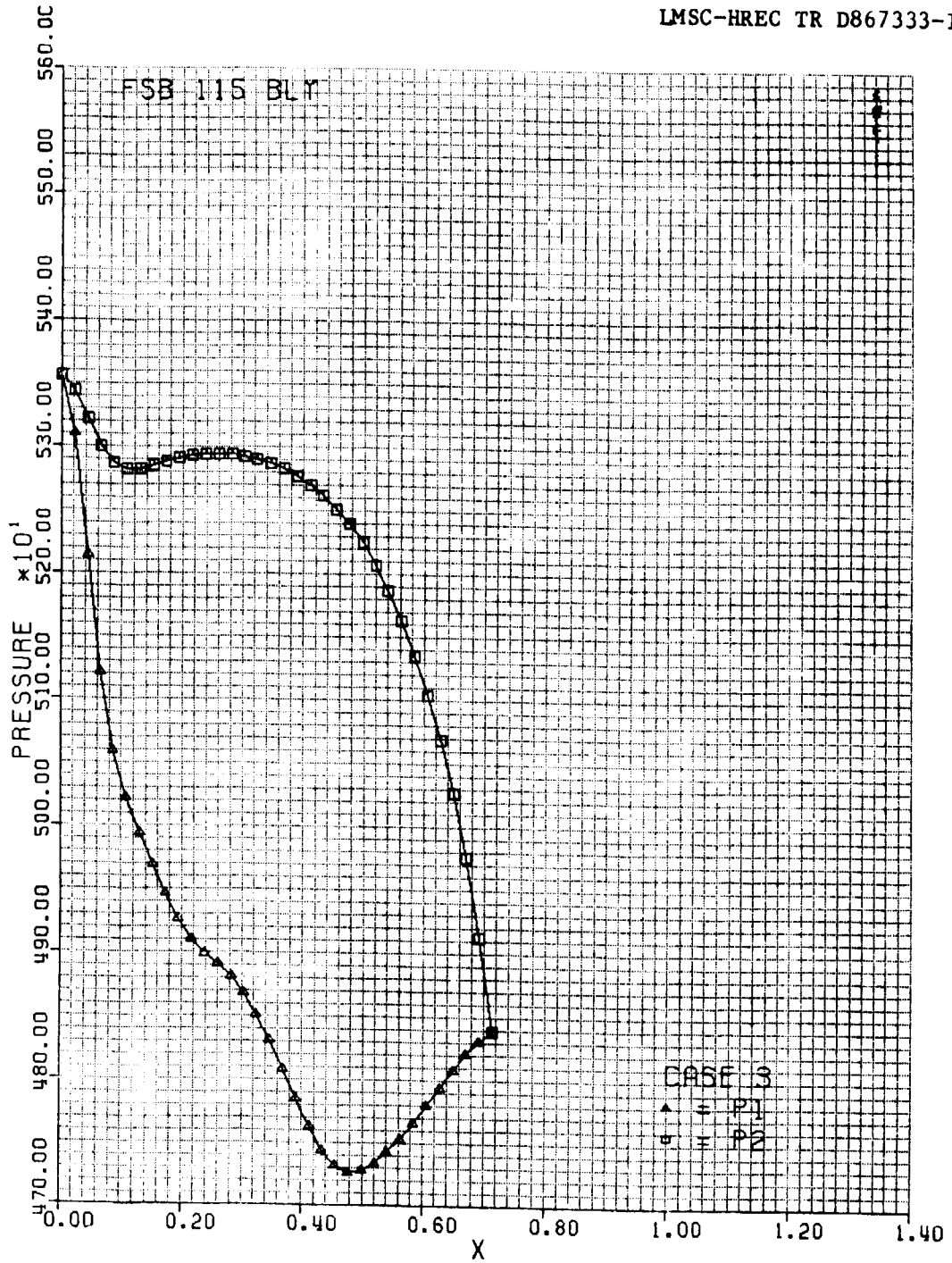

B.2.3

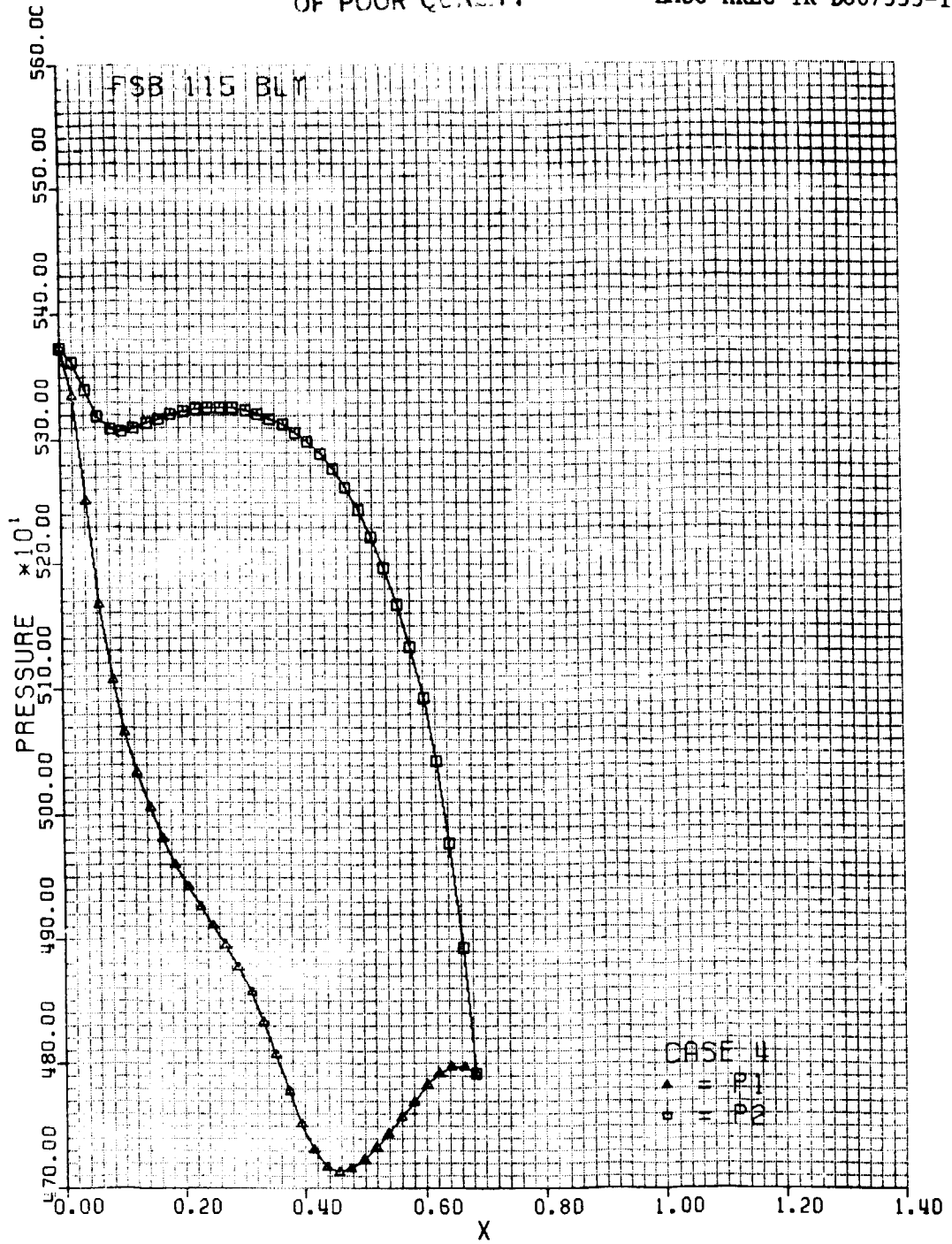

B.2.4

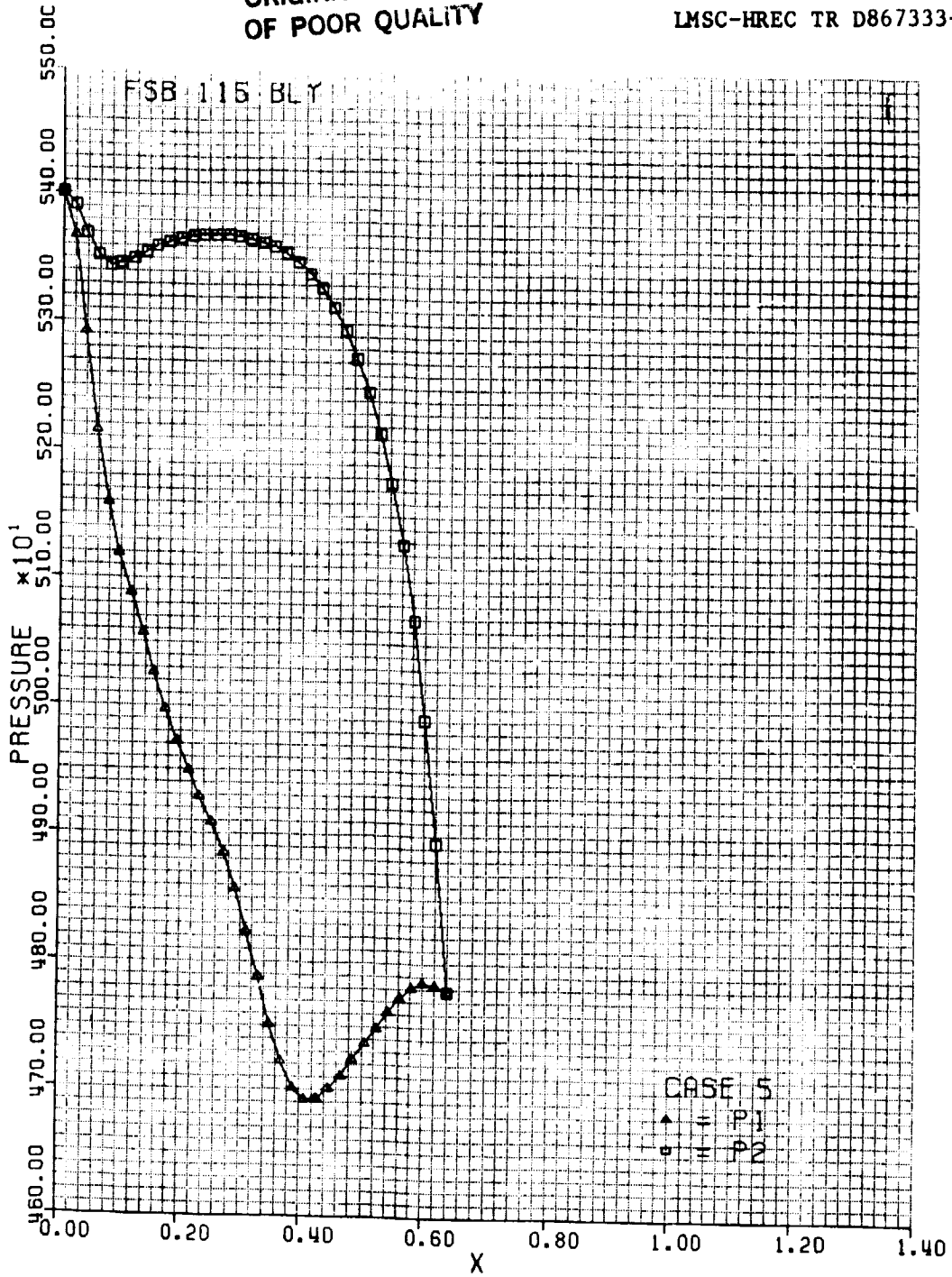

B.2.5

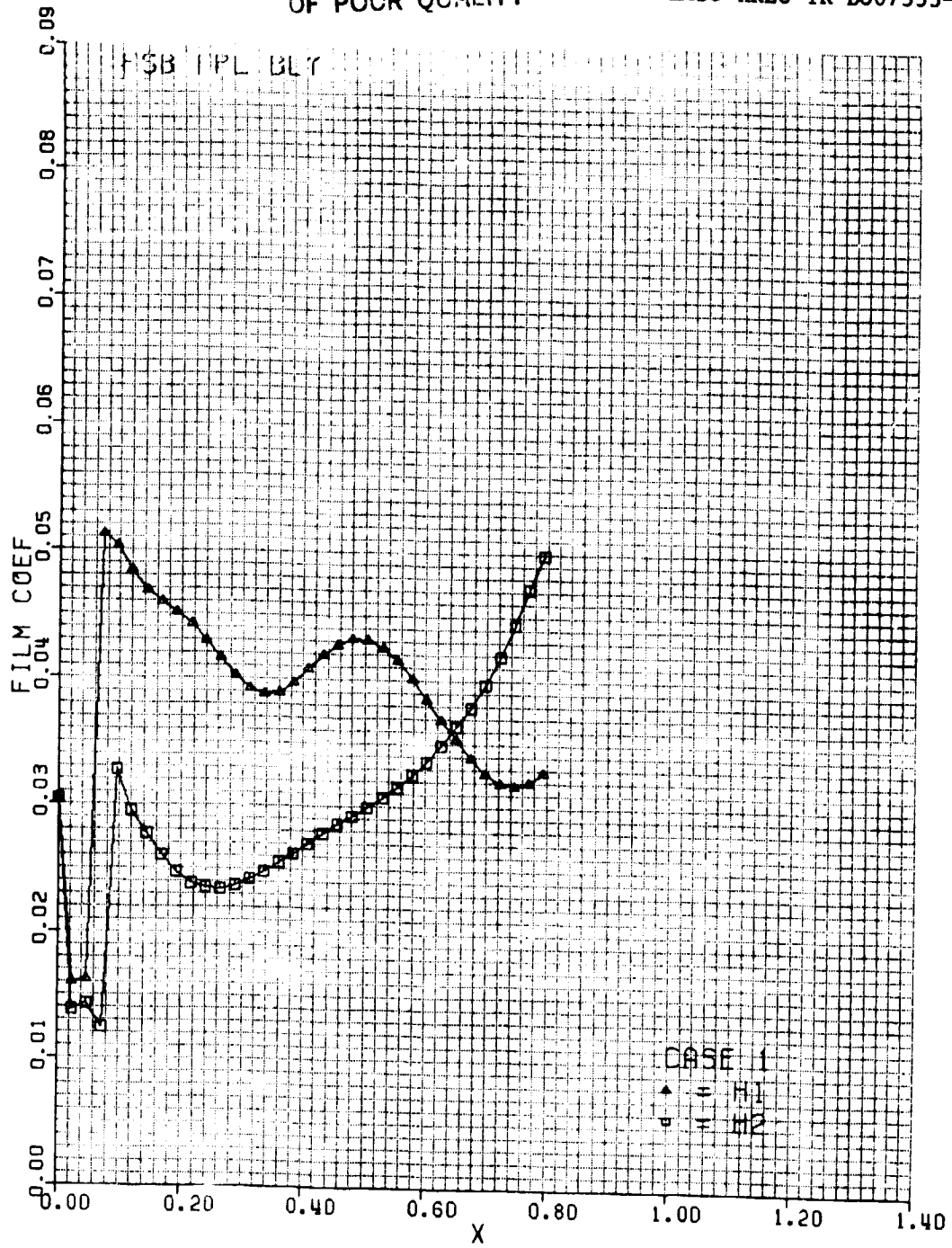

B.3.1

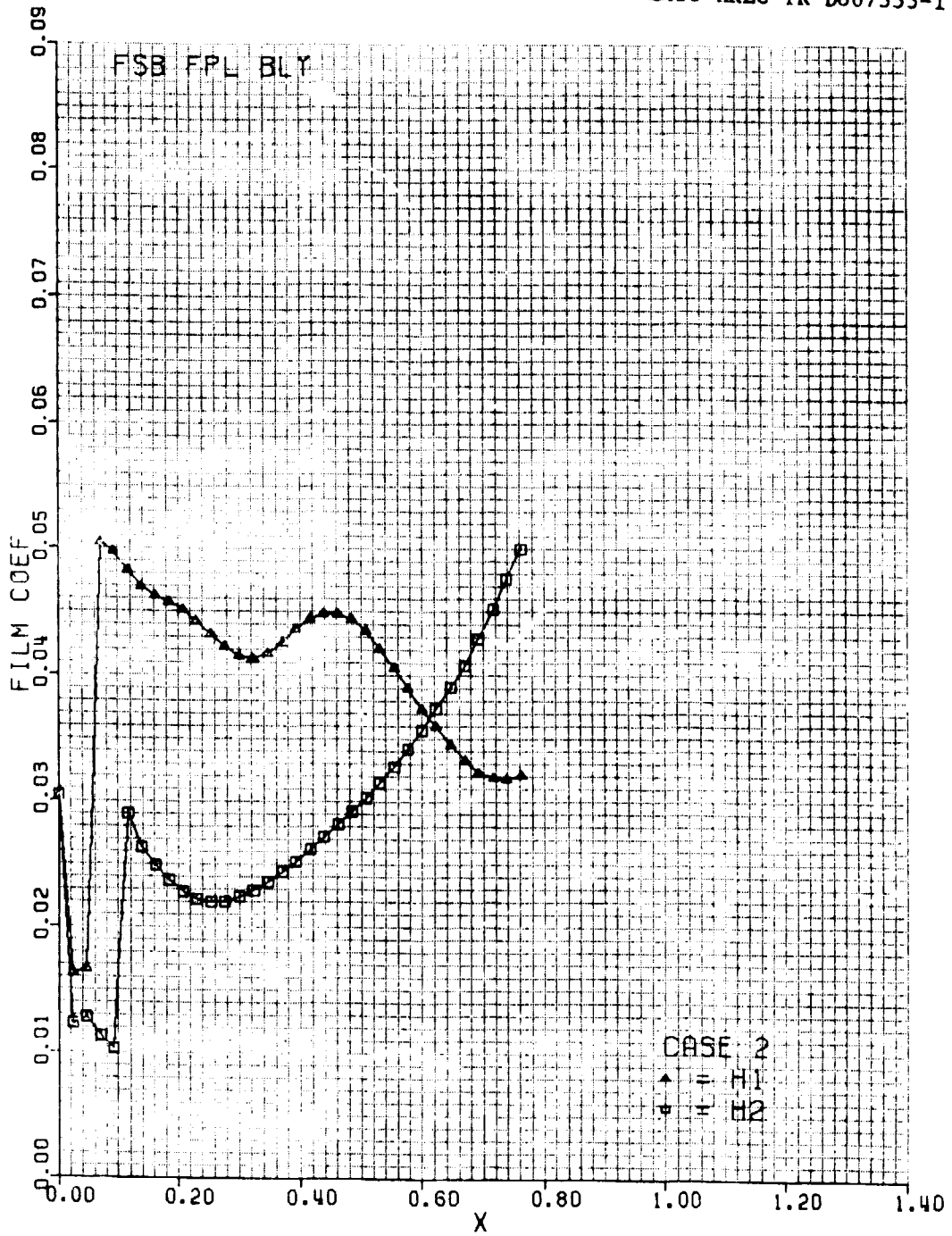

B.3.2

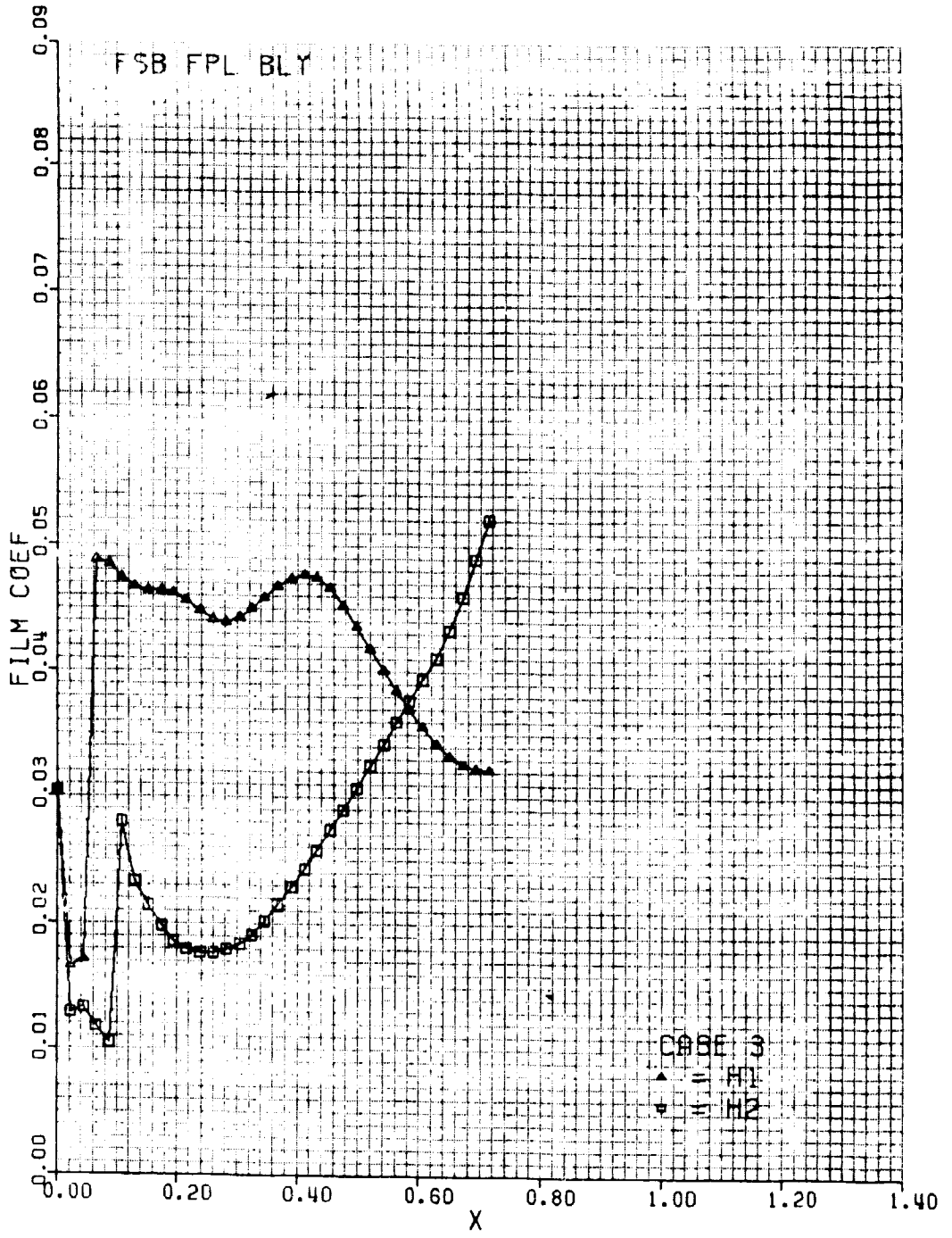

B.3.3

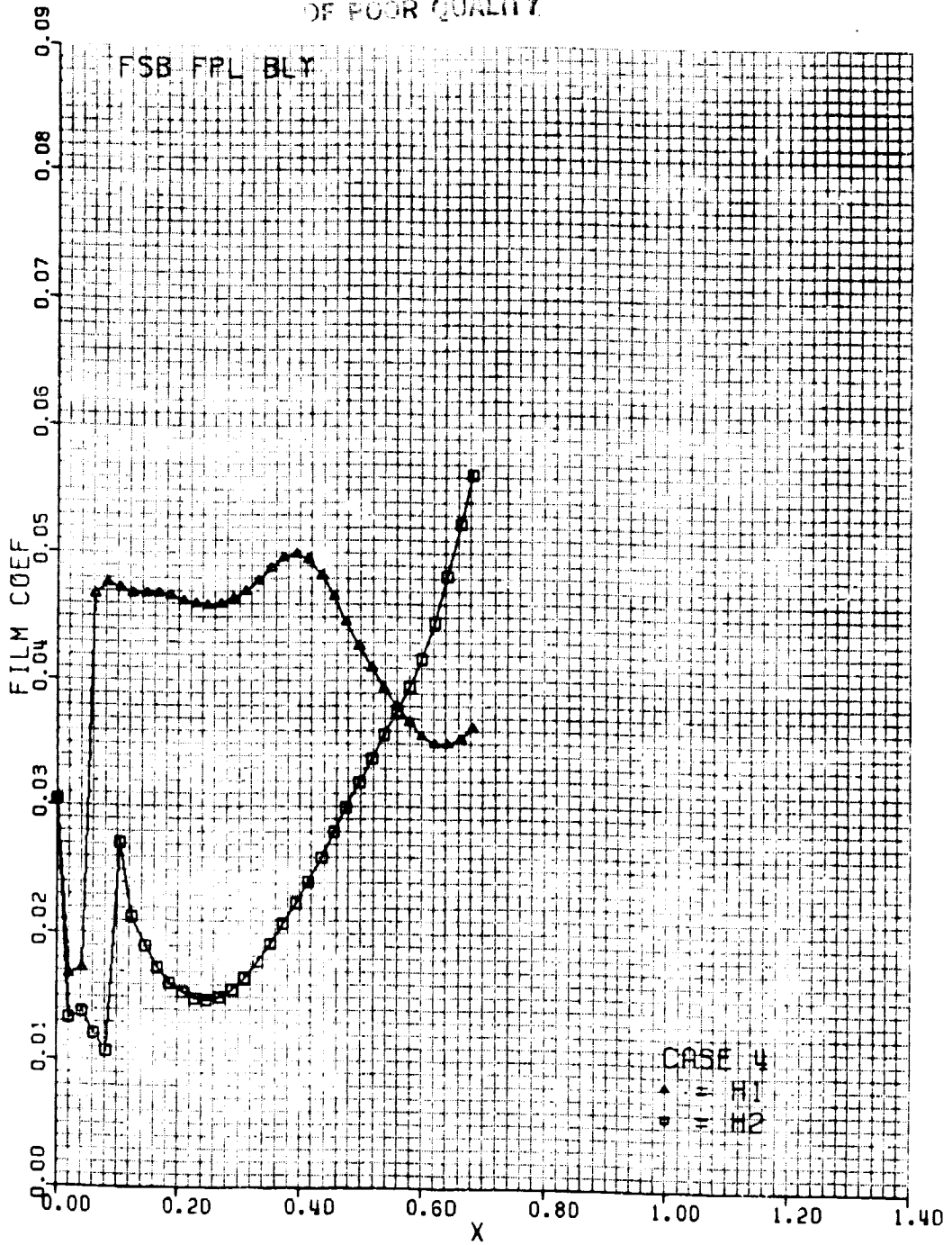

B.3.4

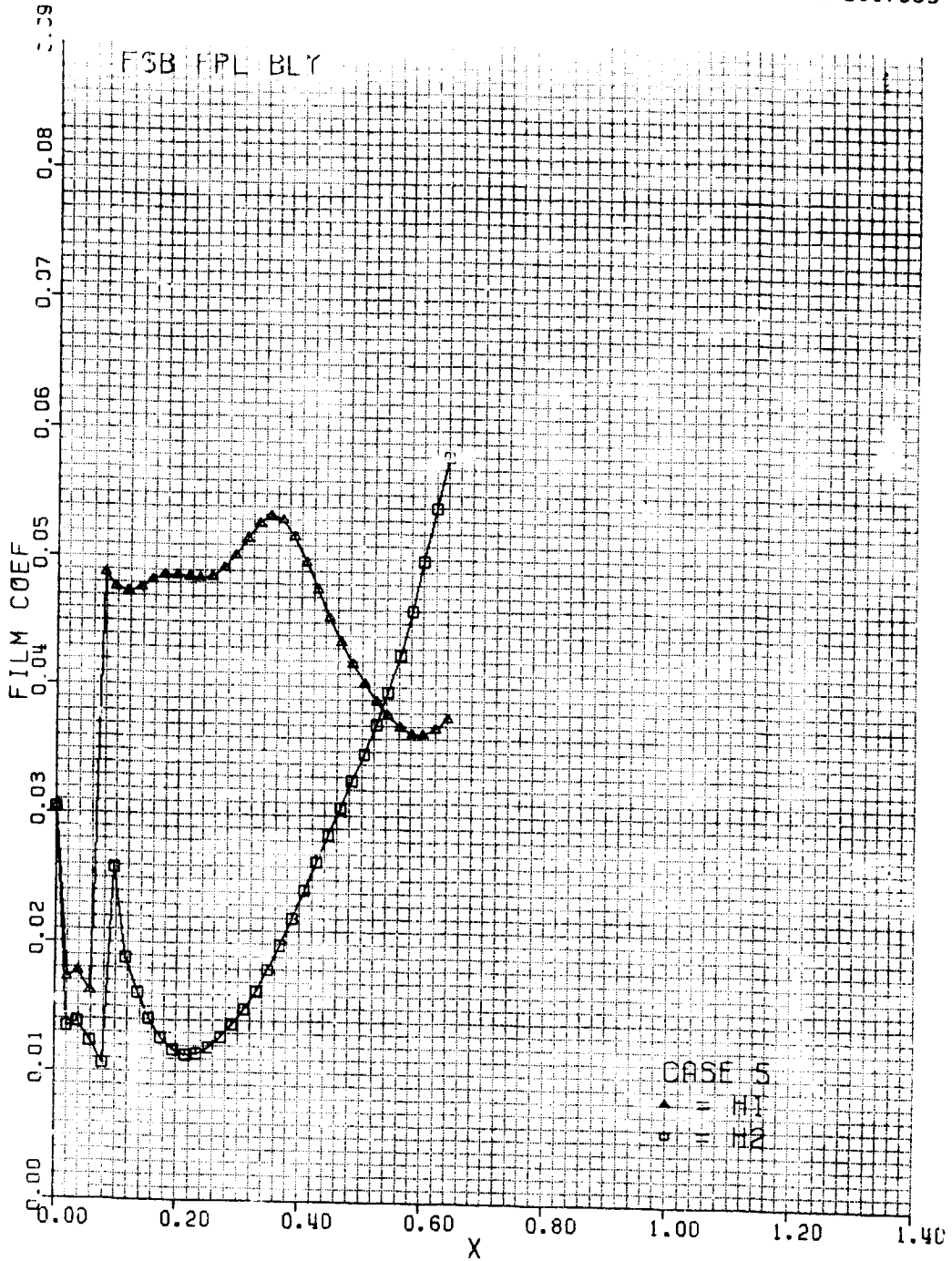

B.3.5

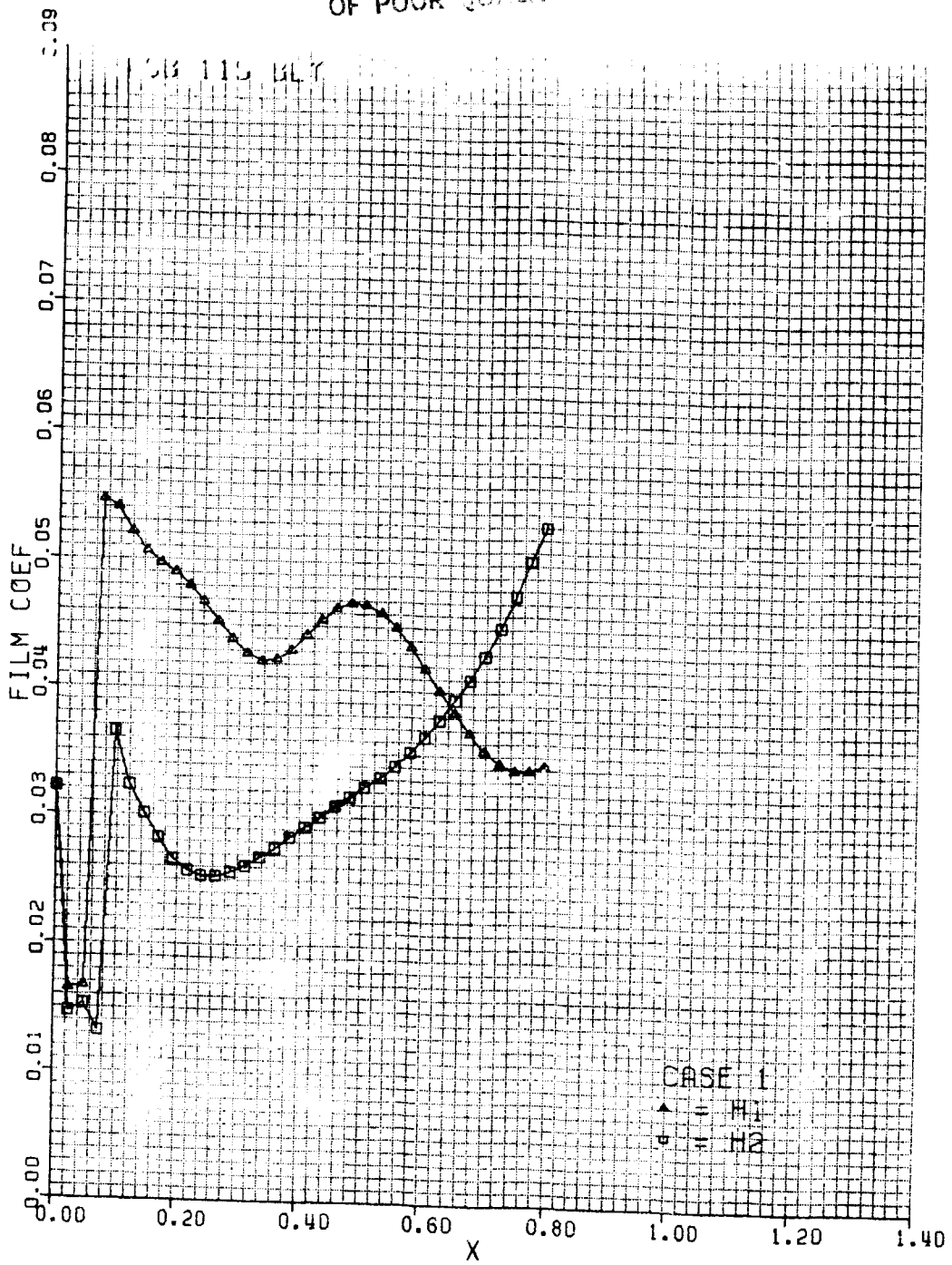

B.4.1

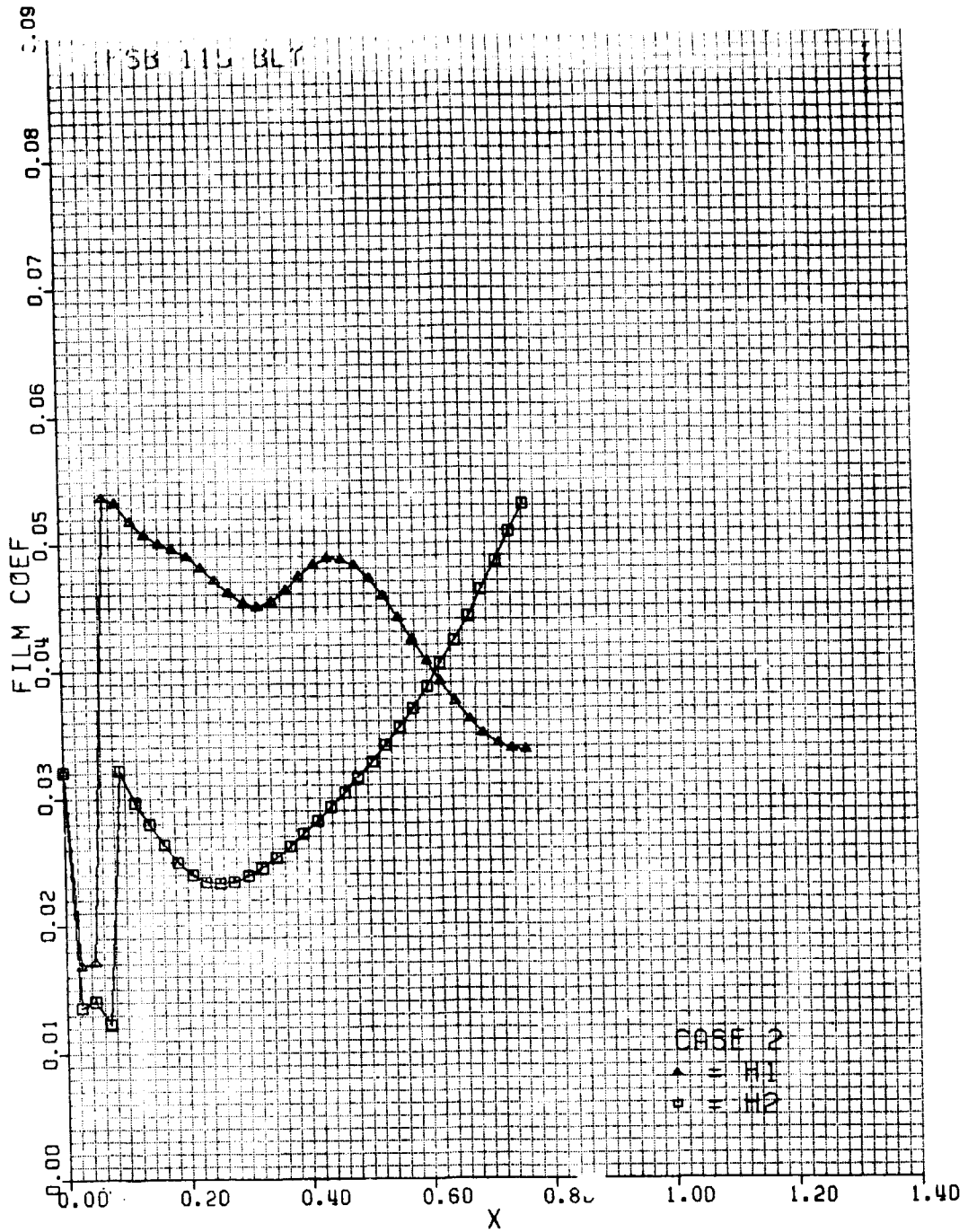

B.4.2

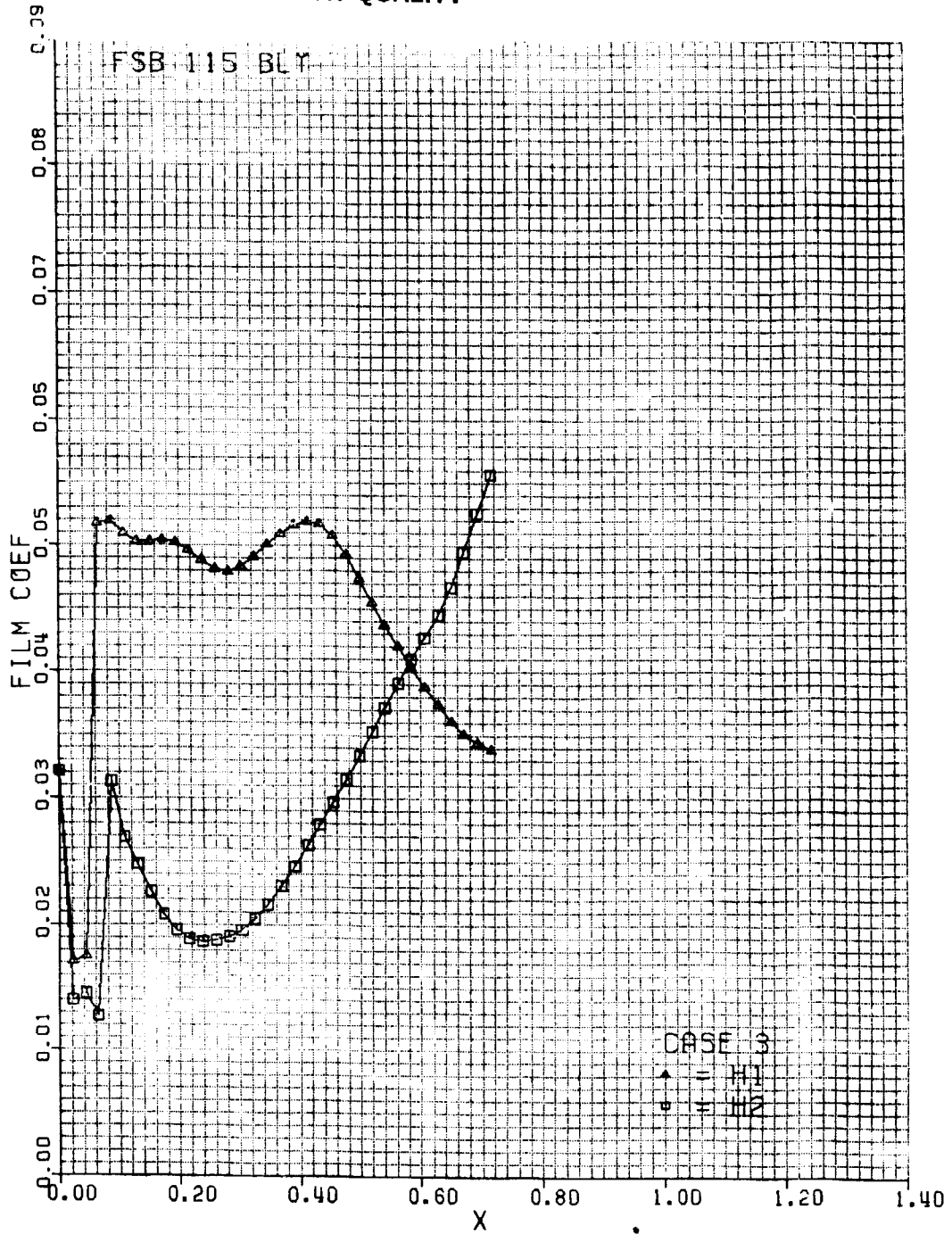

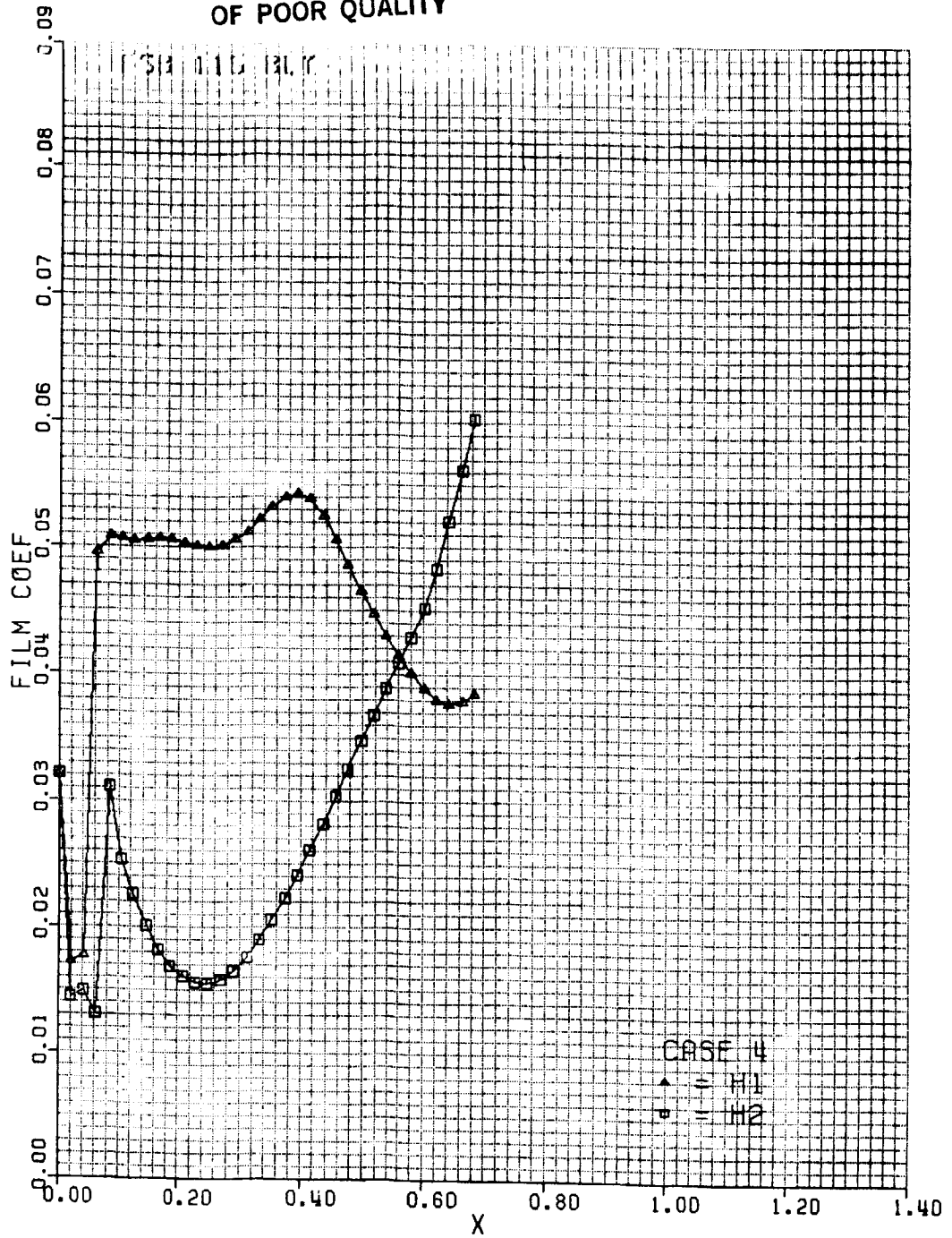

B.4.4

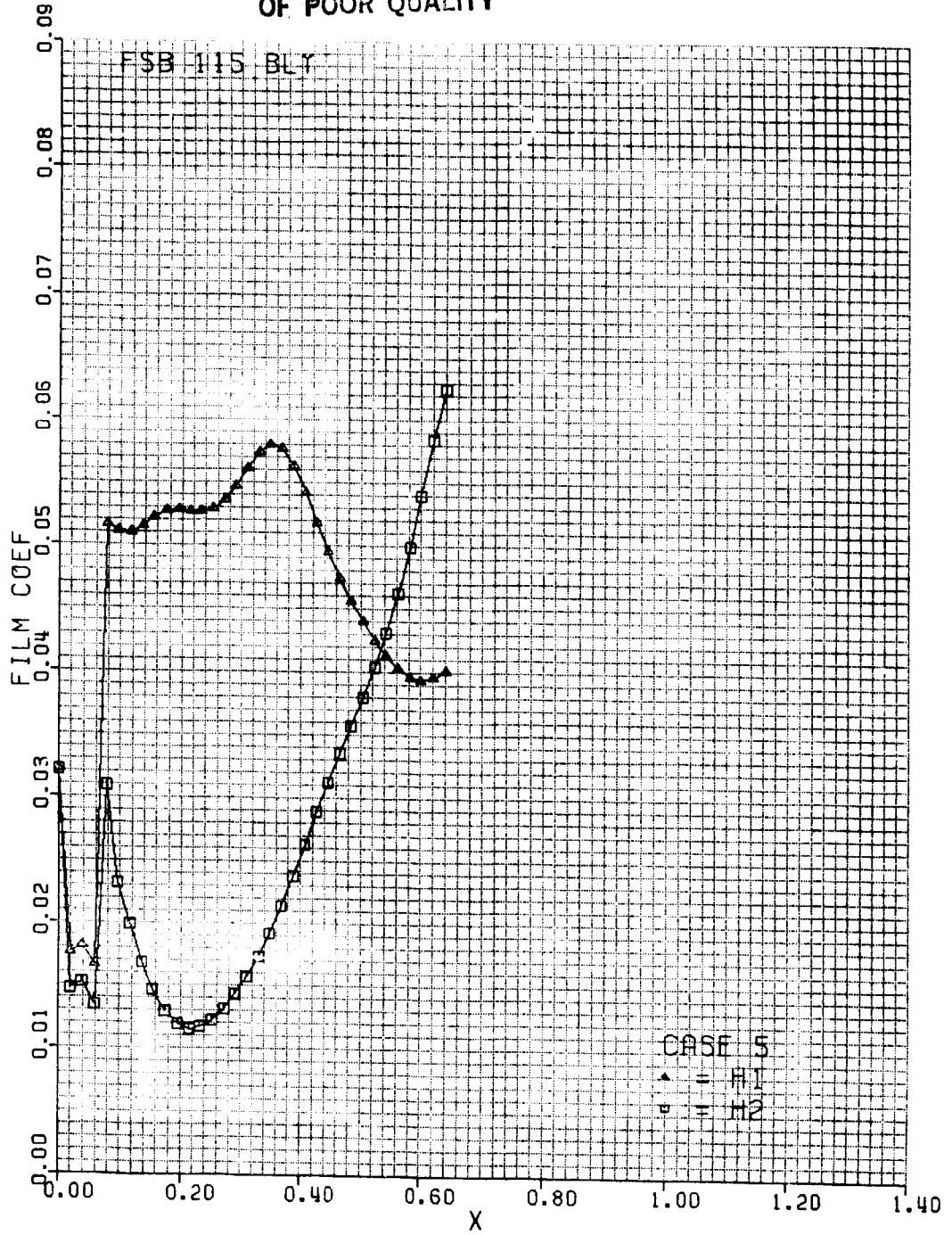

B.4.5

Appendix C

HPFTP SECOND STAGE BLADE PRESSURE, ADIABATIC WALL
TEMPERATURE AND HEAT TRANSFER
COEFFICIENT DISTRIBUTIONS

- C.1 FPL Pressure Distributions
- C.2 115 Percent Power Level Pressure Distributions
- C.3 FPL Heat Transfer Coefficients
- C.4 115 Percent Power Level Heat Transfer Coefficients

Surface 1 - Suction Surface \triangle
Surface 2 - Pressure Surface \square

Approximate Adiabatic Wall
Temperatures (F)

	FPL	115 Percent
Case 1 - R = 4.5936 Hub	1390	1340
Case 2 - R = 4.80 Intermediate	↓	↓
Case 3 - R = 5.0795 Mean	↓	↓
Case 4 - R = 5.29 Intermediate	↓	↓
Case 5 - R = 5.5655 Tip	↓	↓

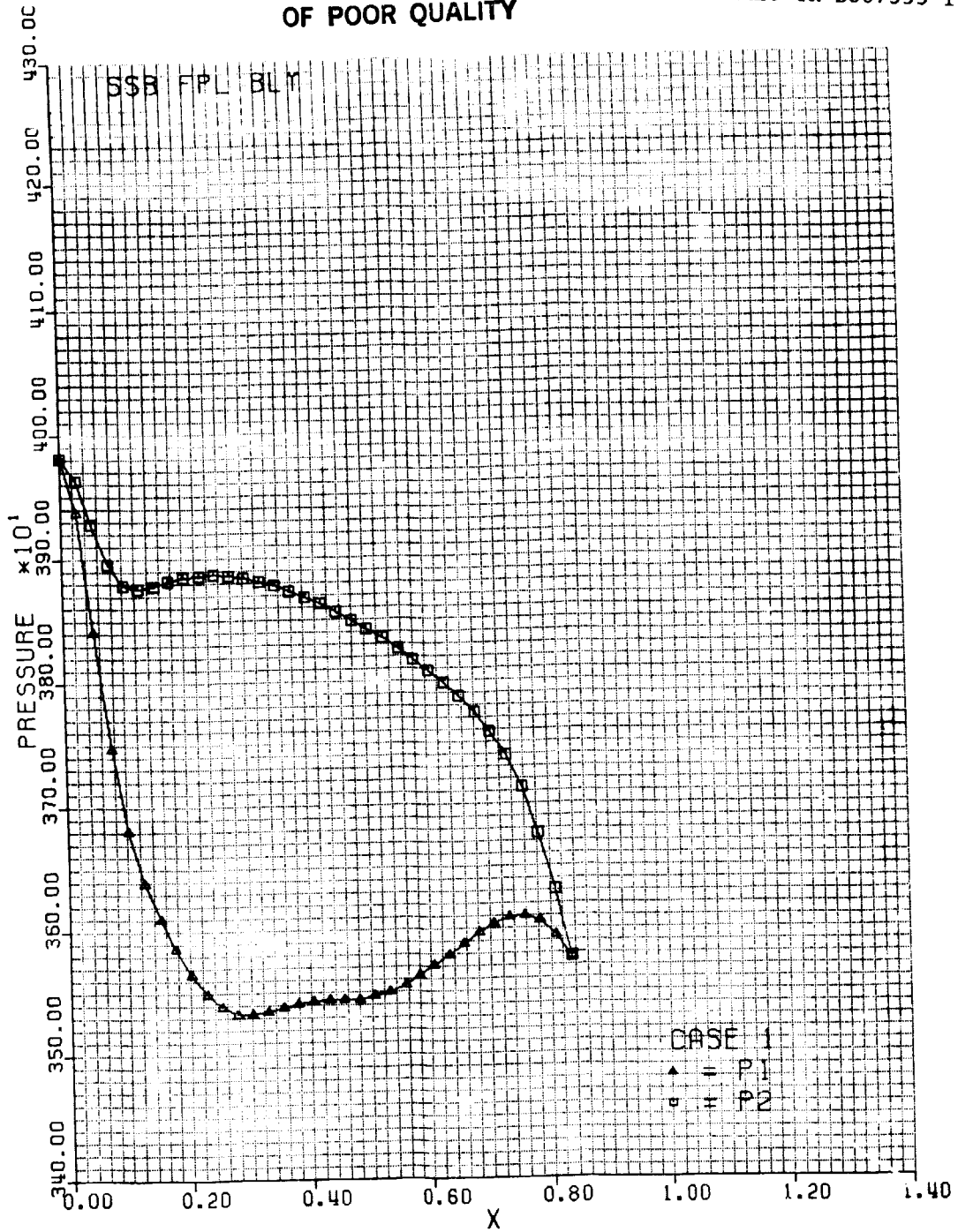

C.1.1

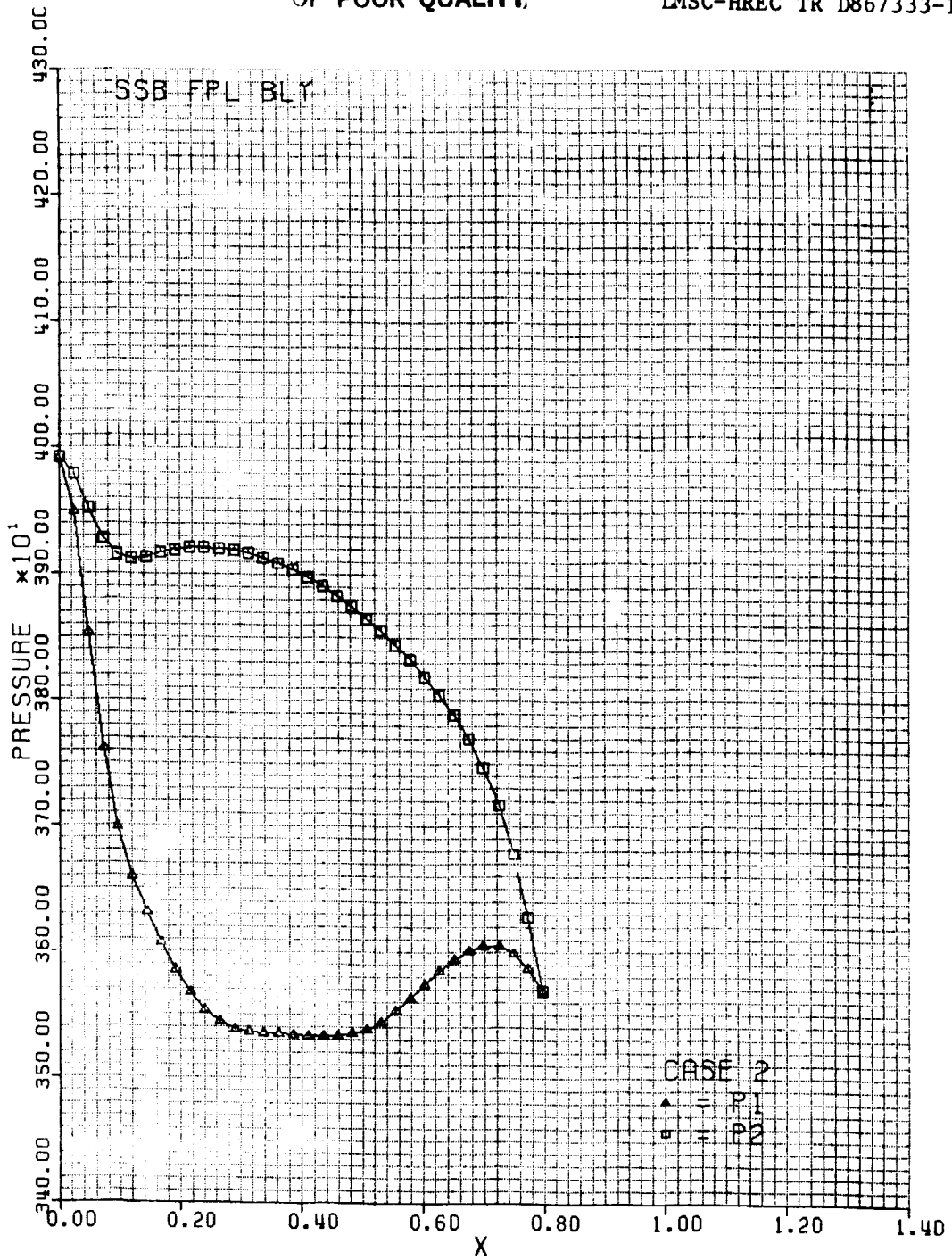

C.1.2

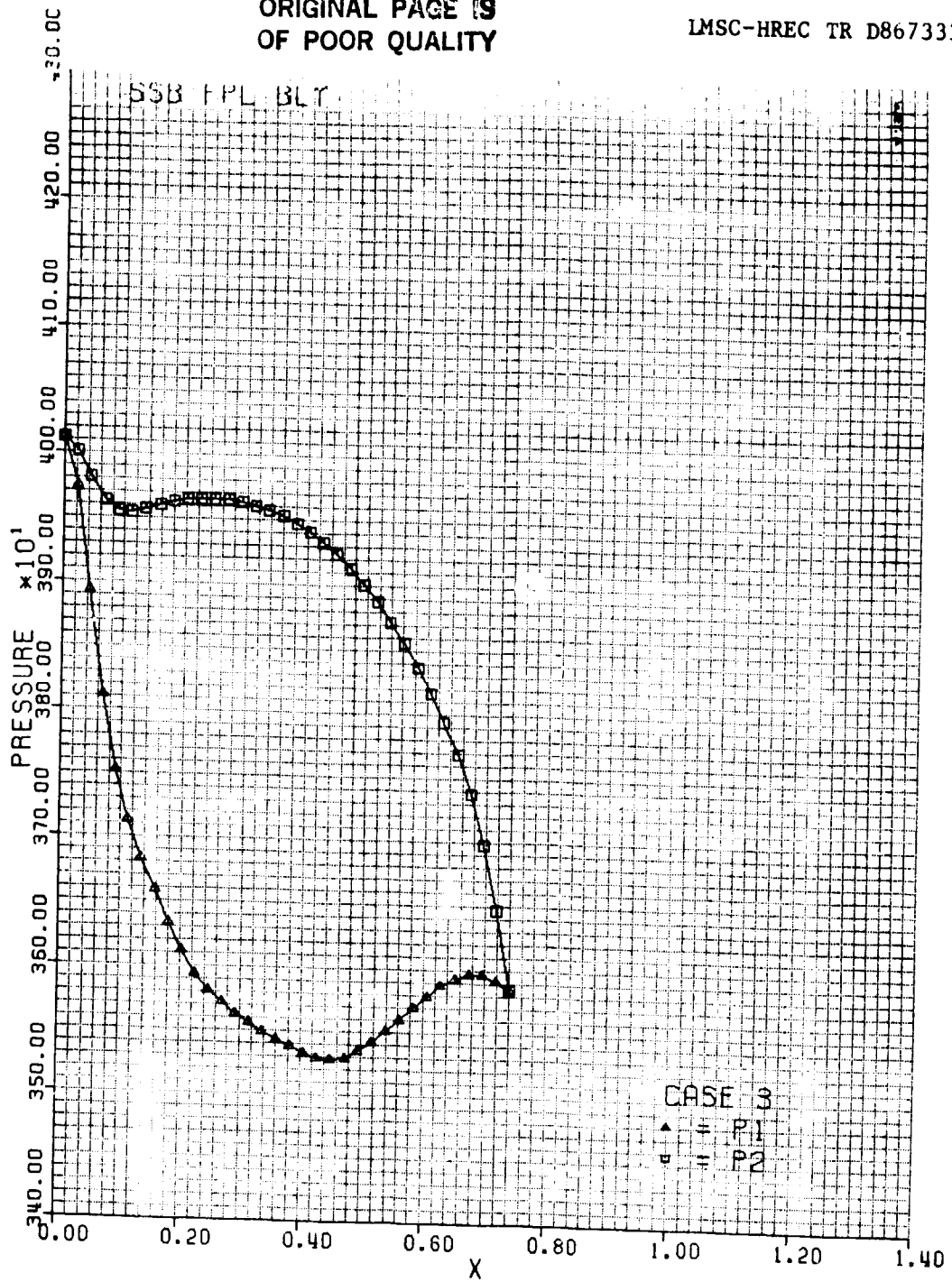

C.1.3

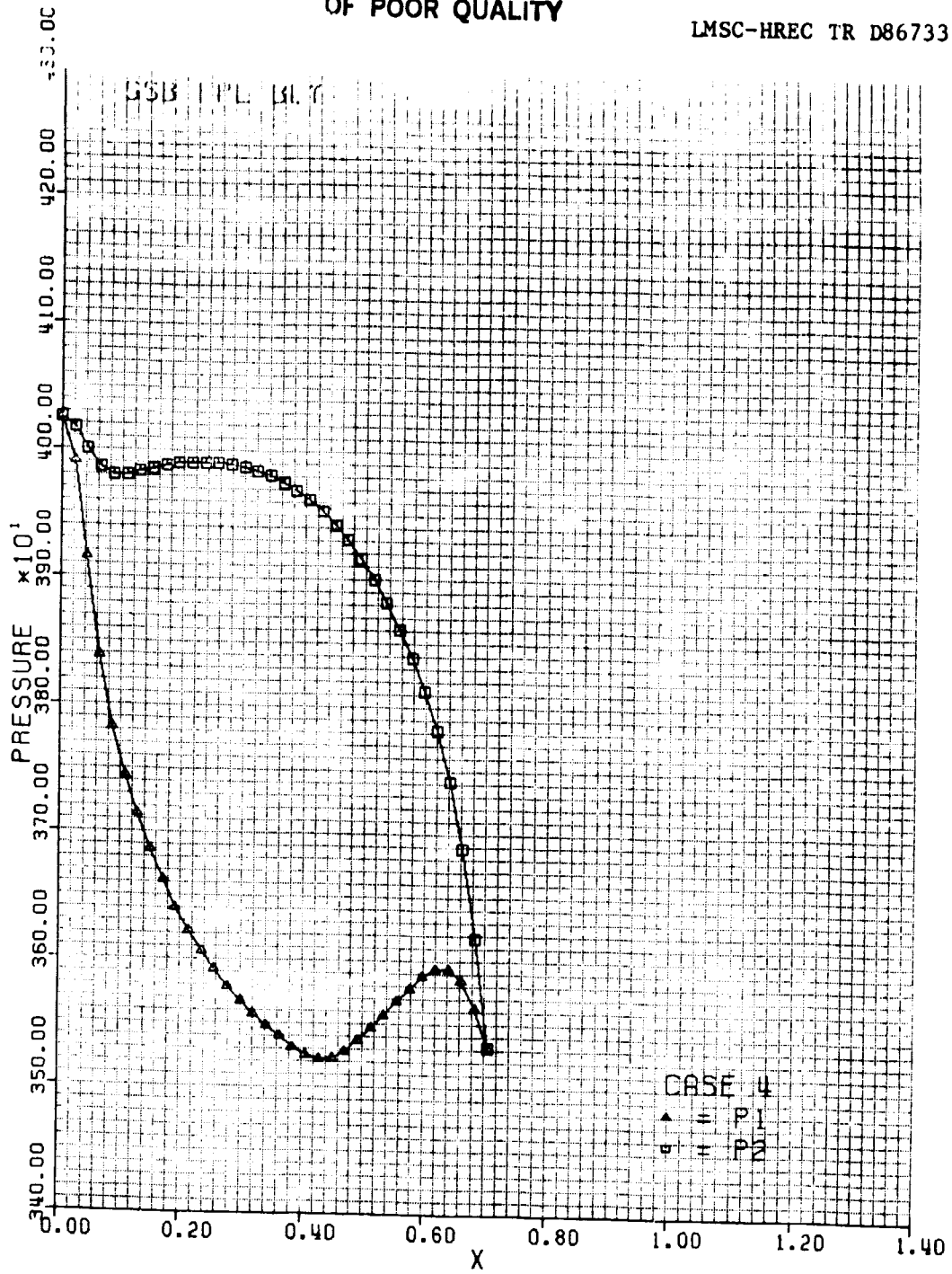

C.1.4

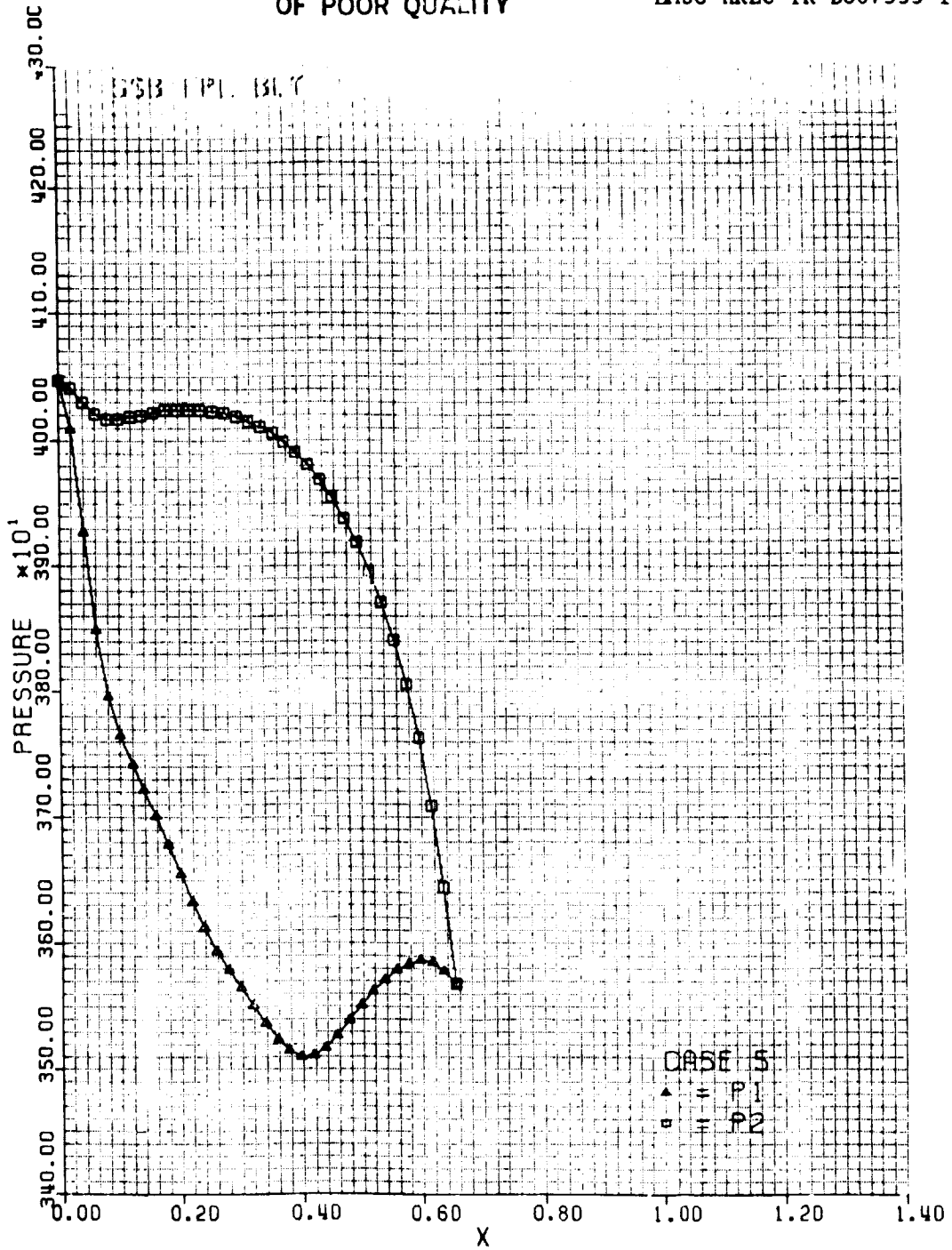

C.1.5

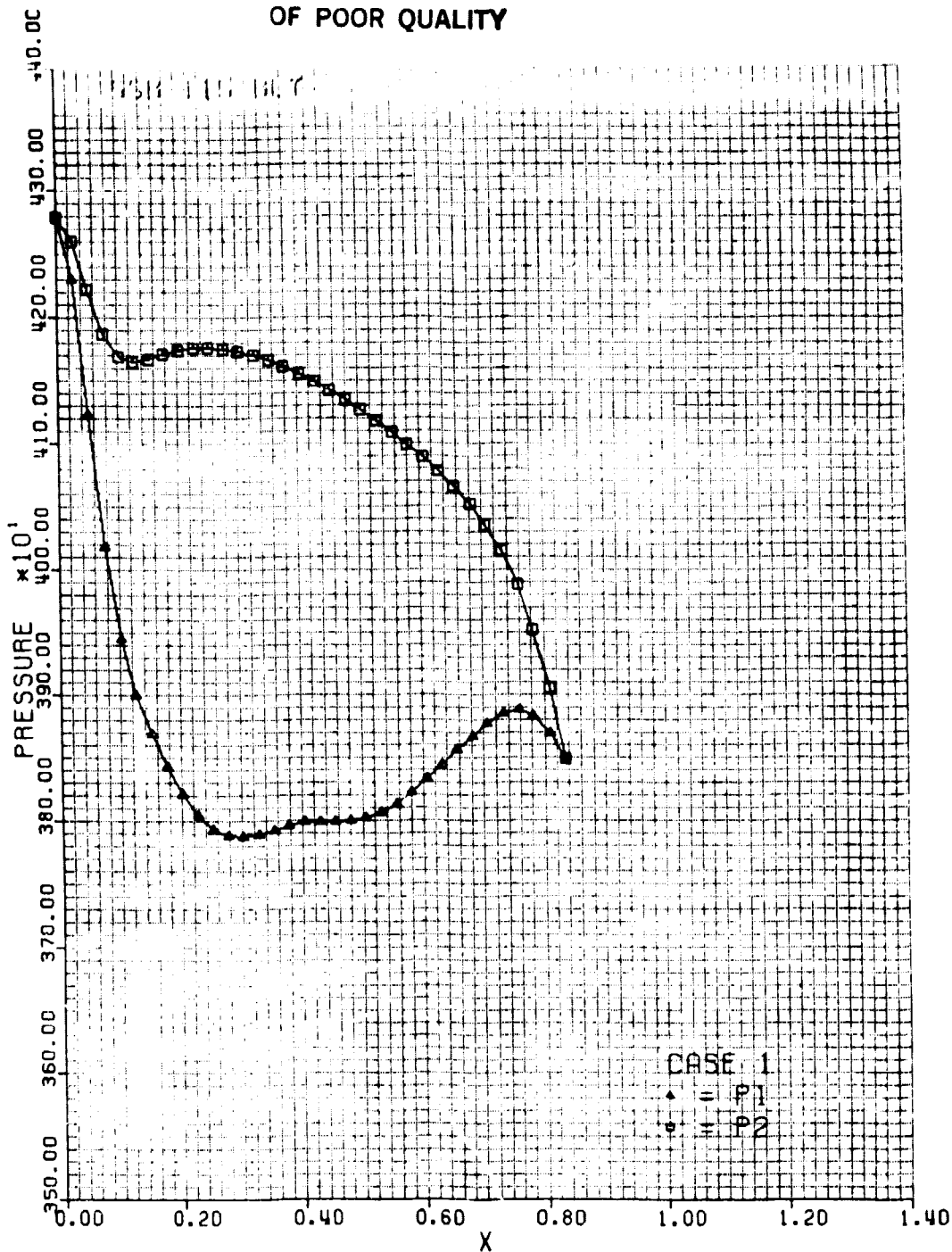

C.2.1

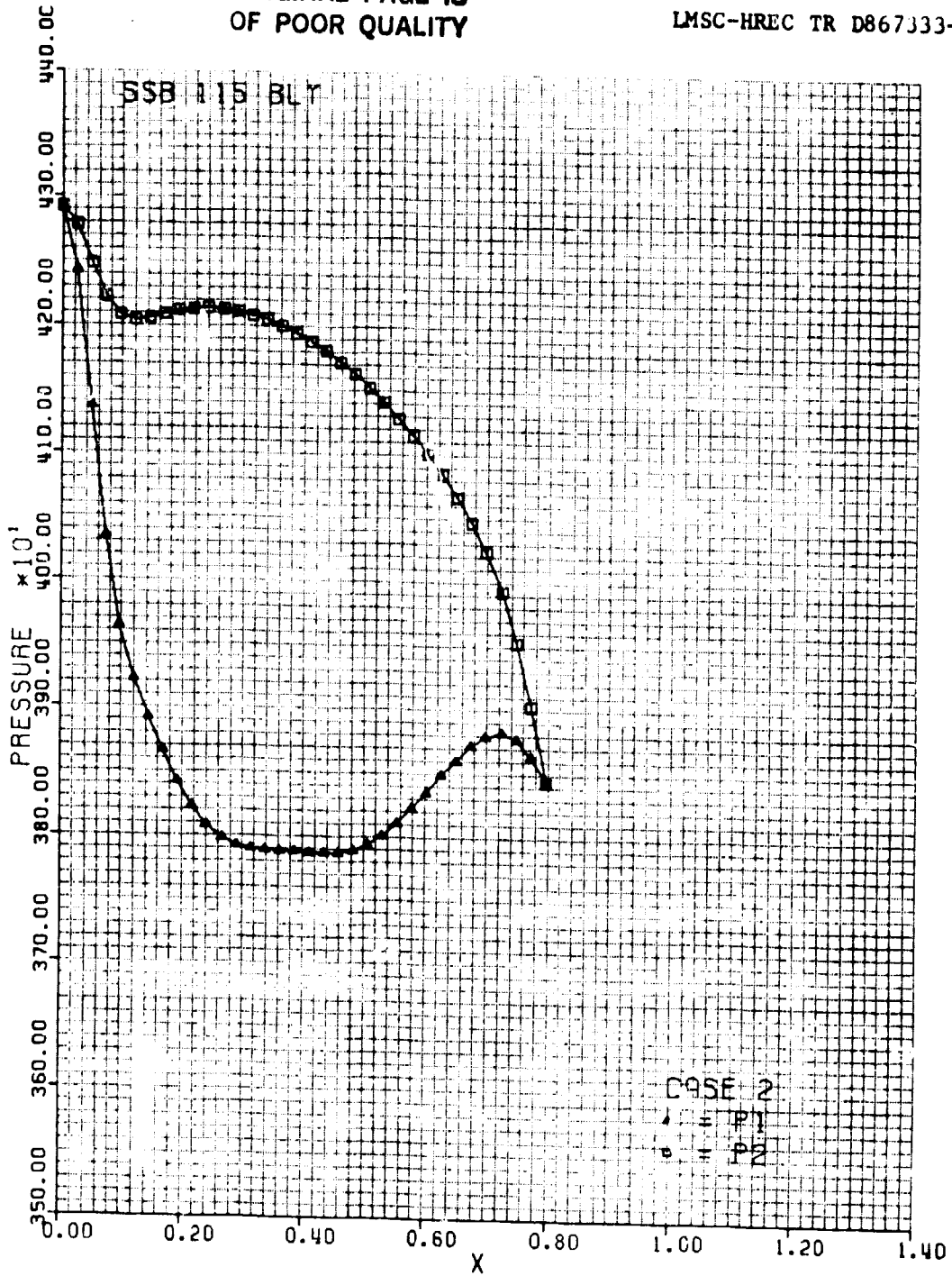

C.2.2

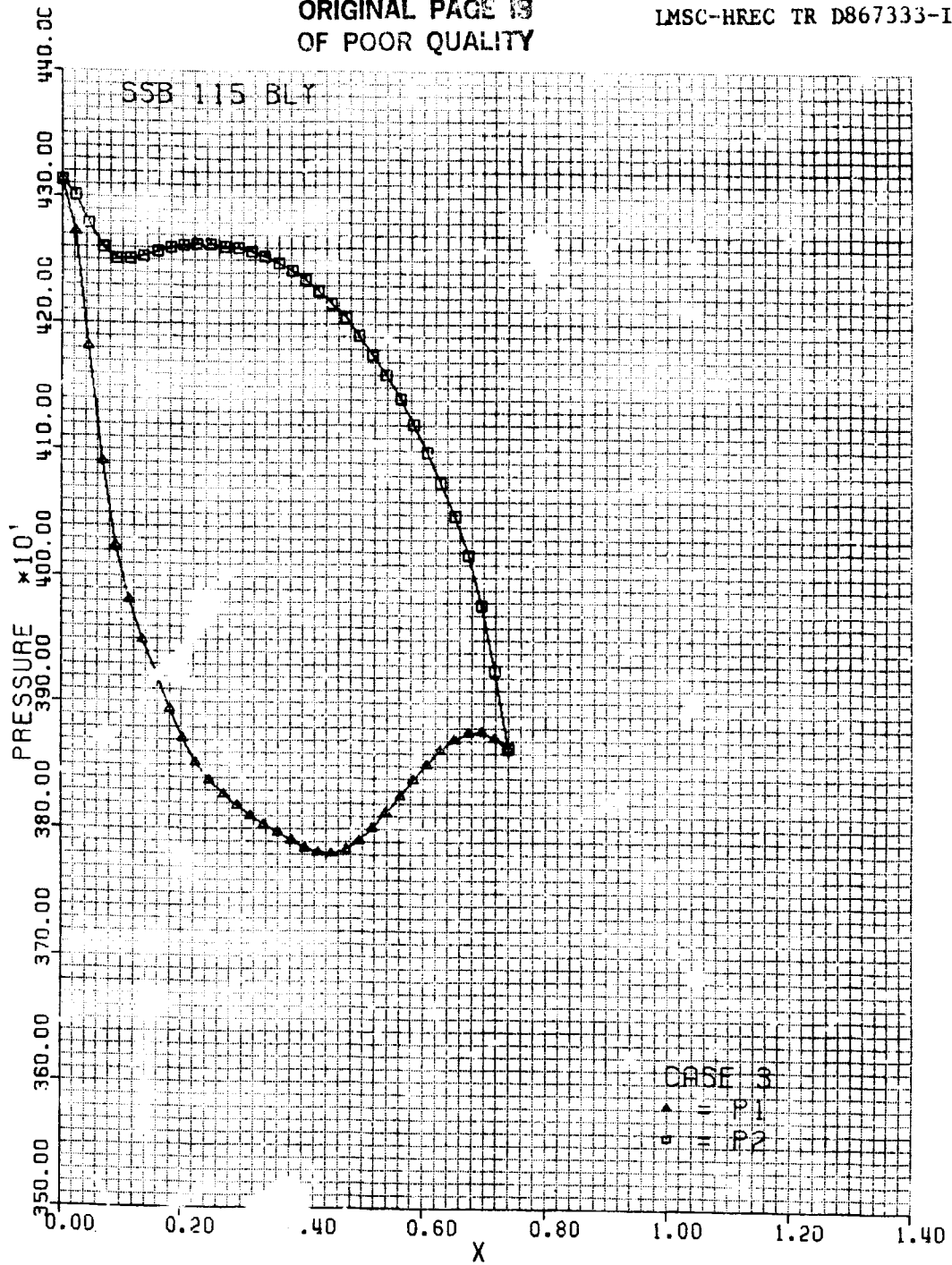

C.2.3

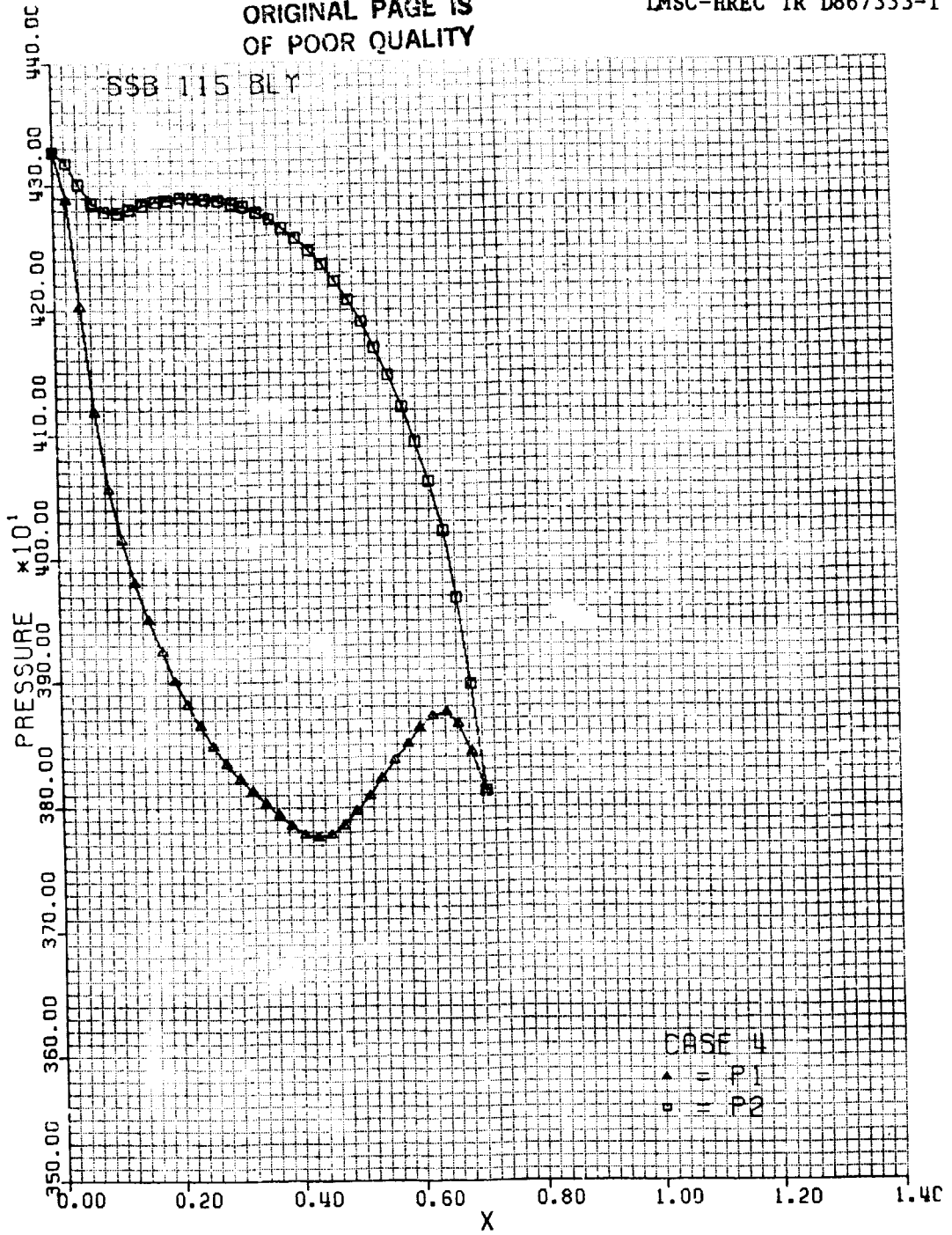

C.2.4

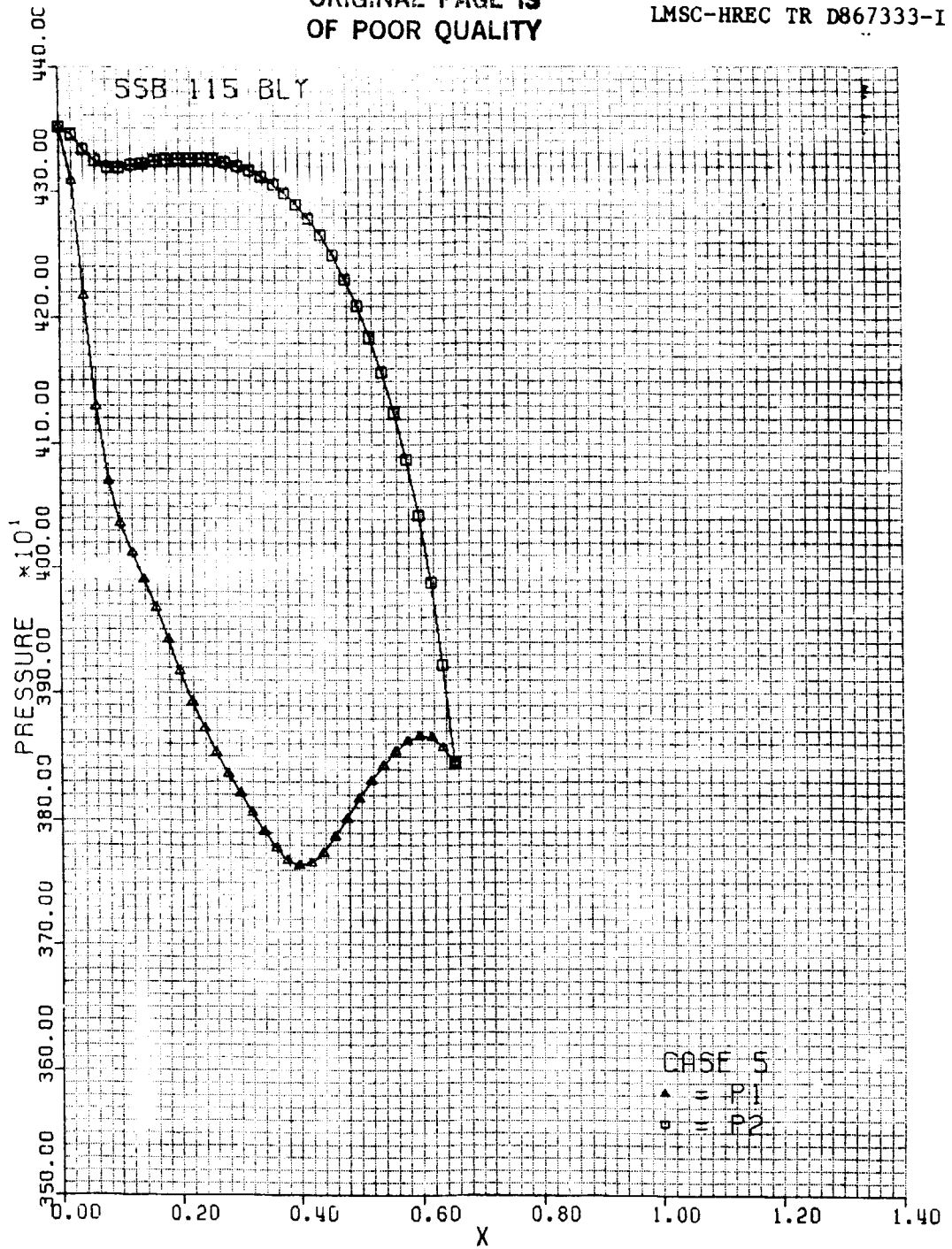

C.2.5

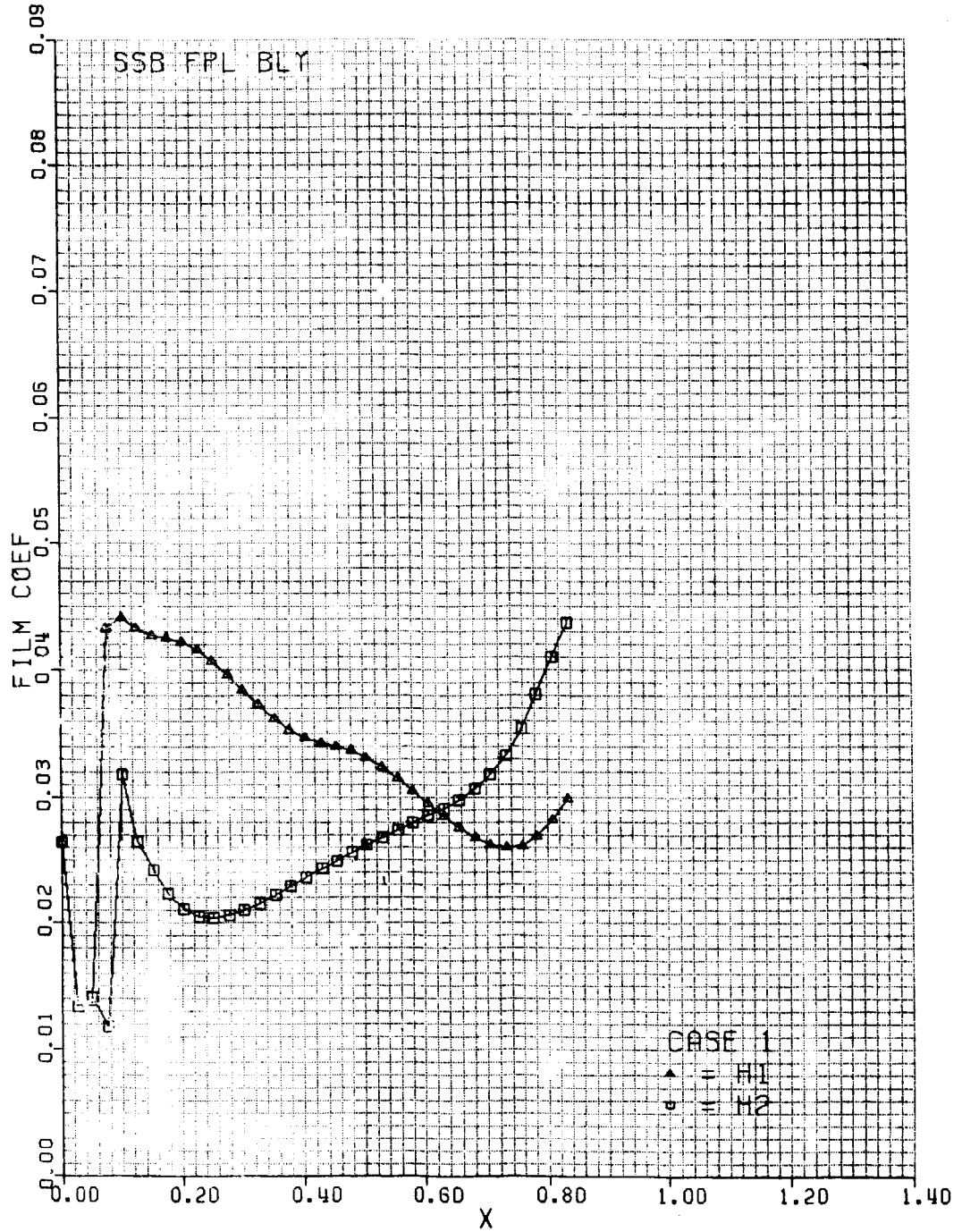

C.3.1

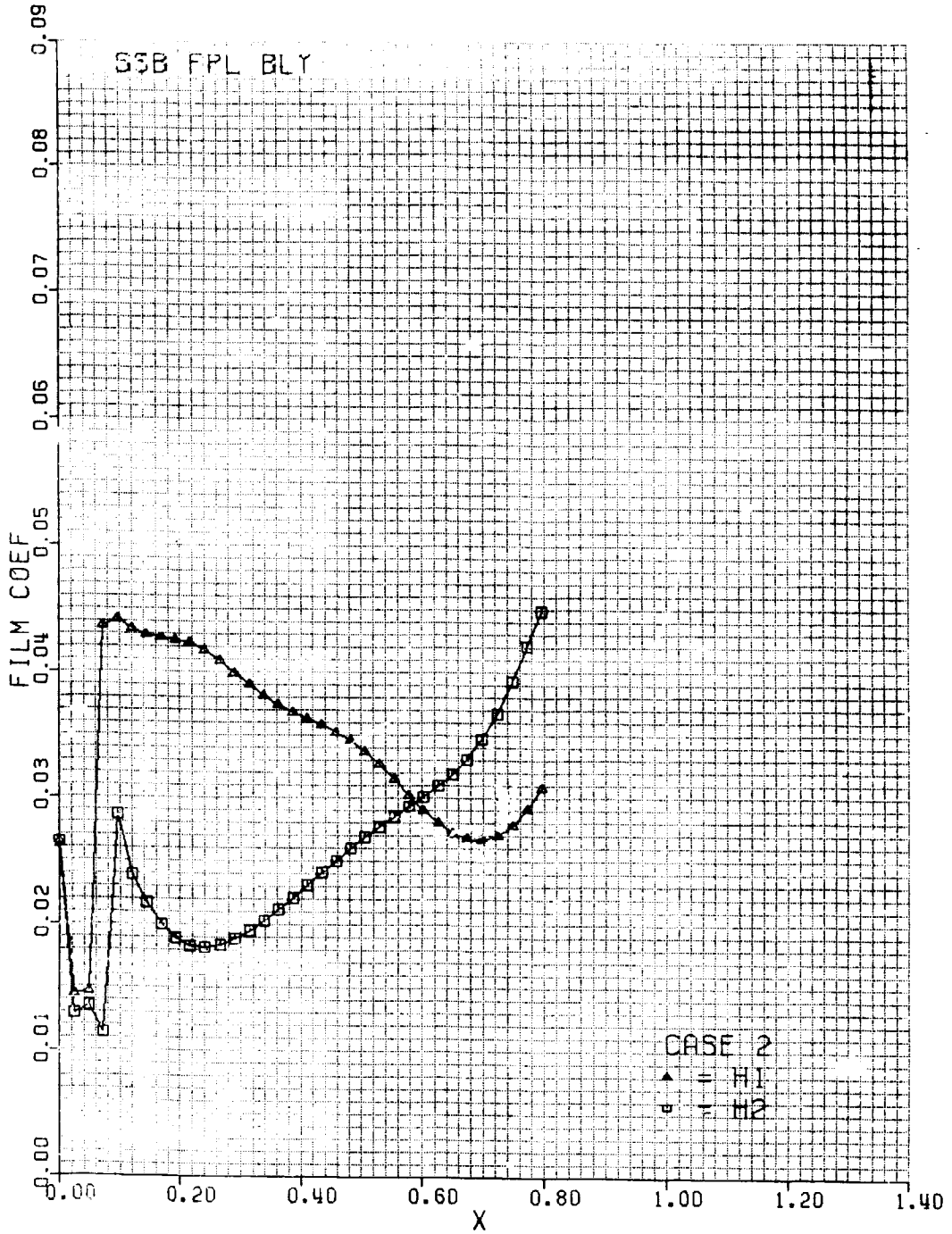

C.3.2

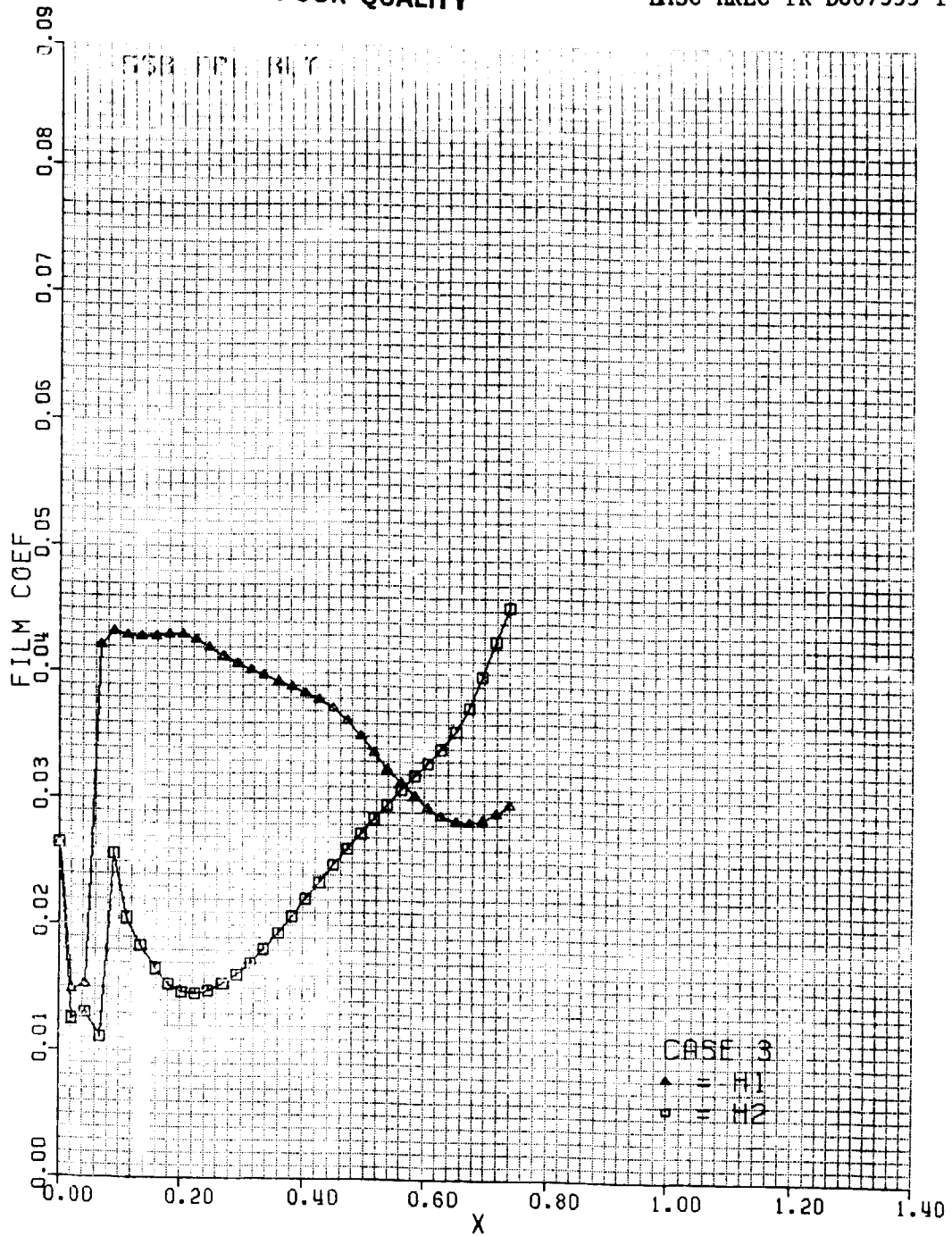

C.3.3

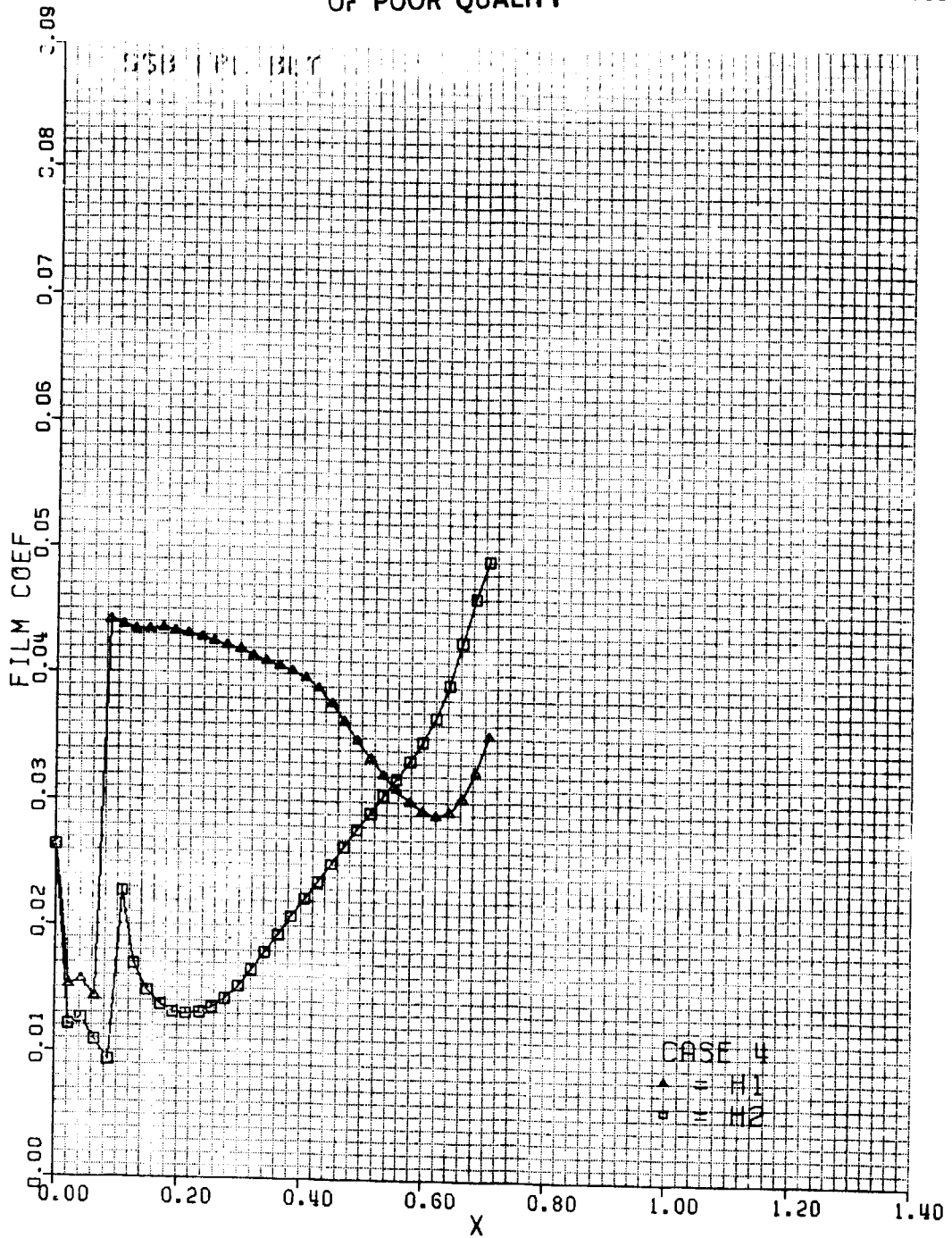

C.3.4

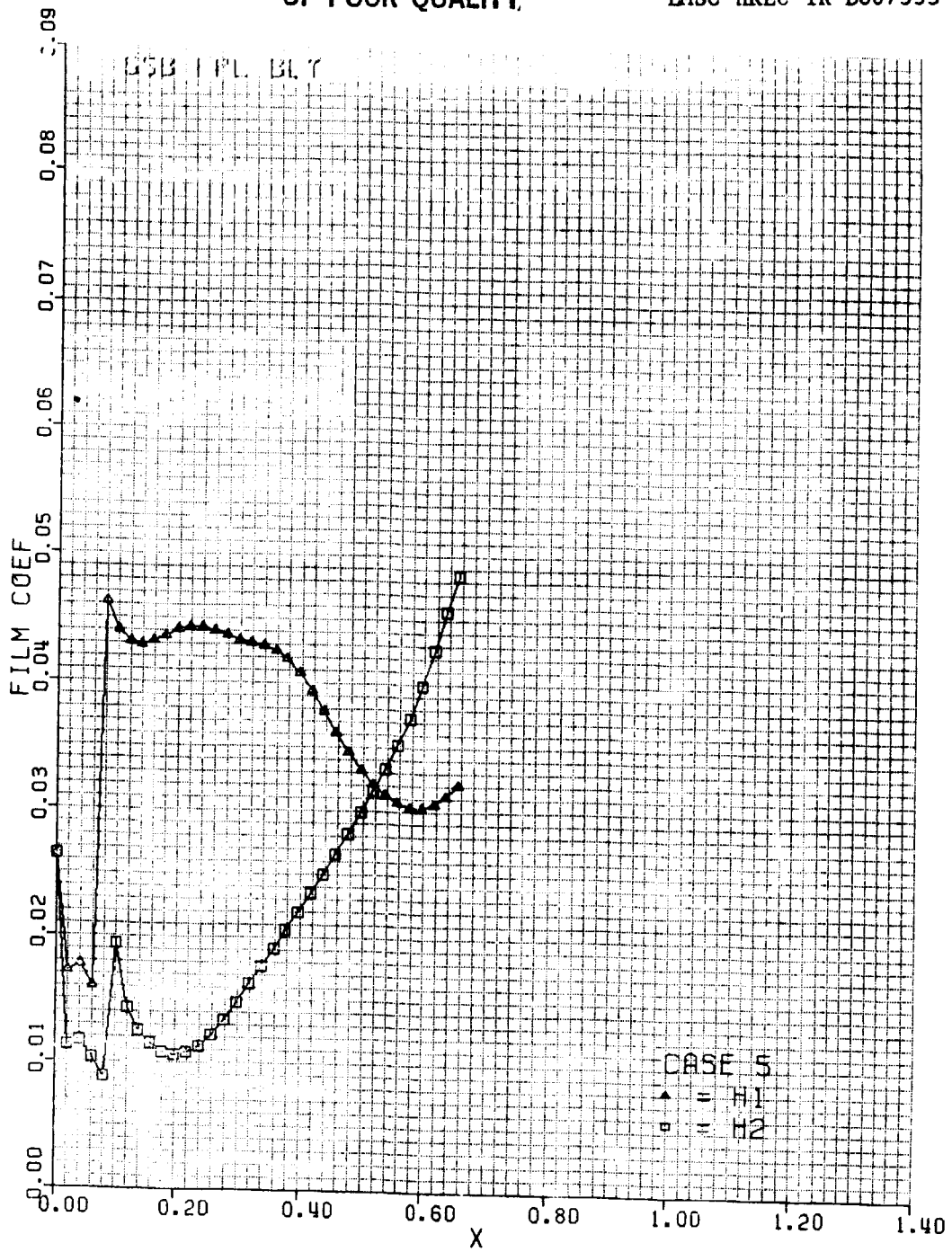

C.3.5

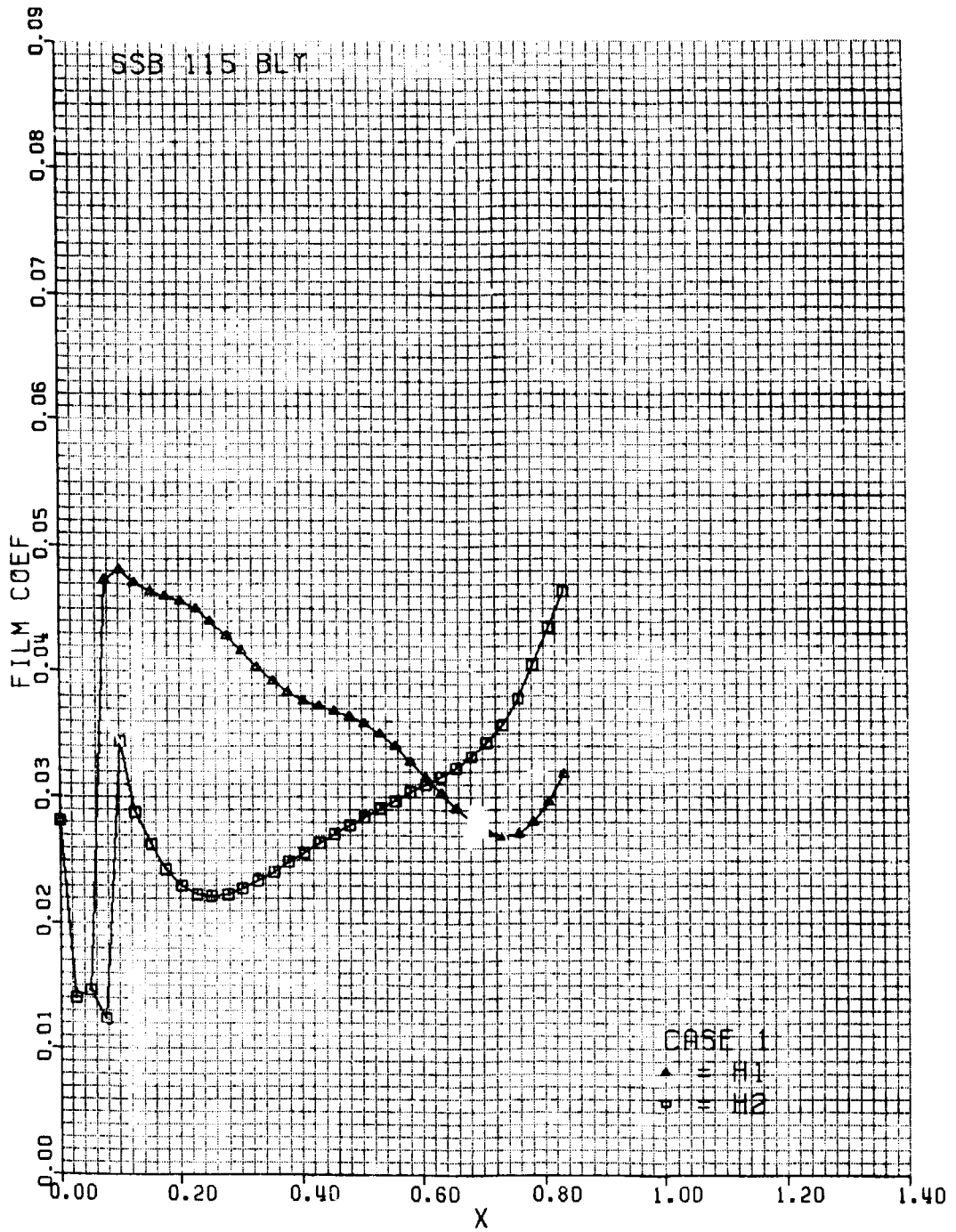

C.4.1

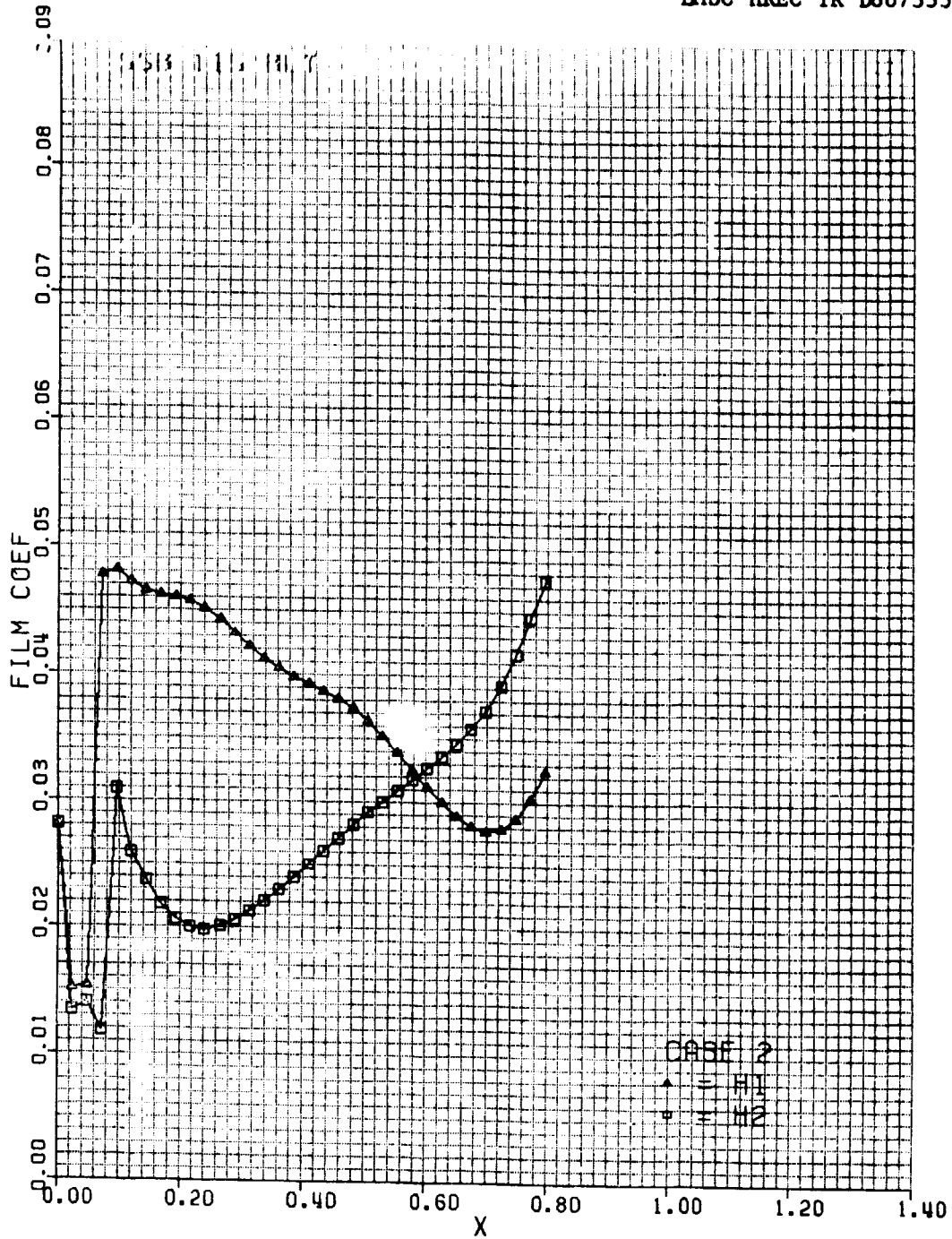

C.4.2

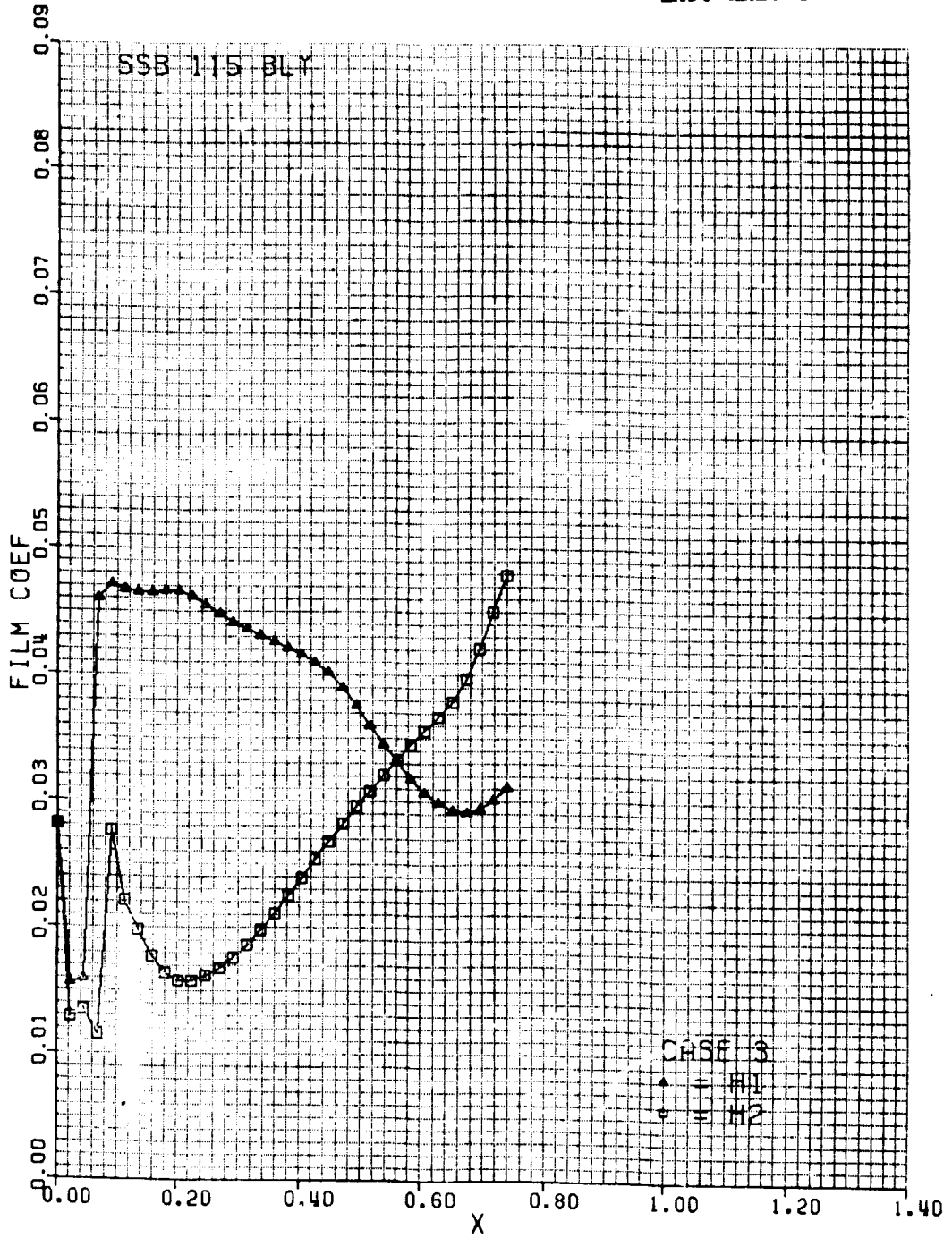

C.4.3

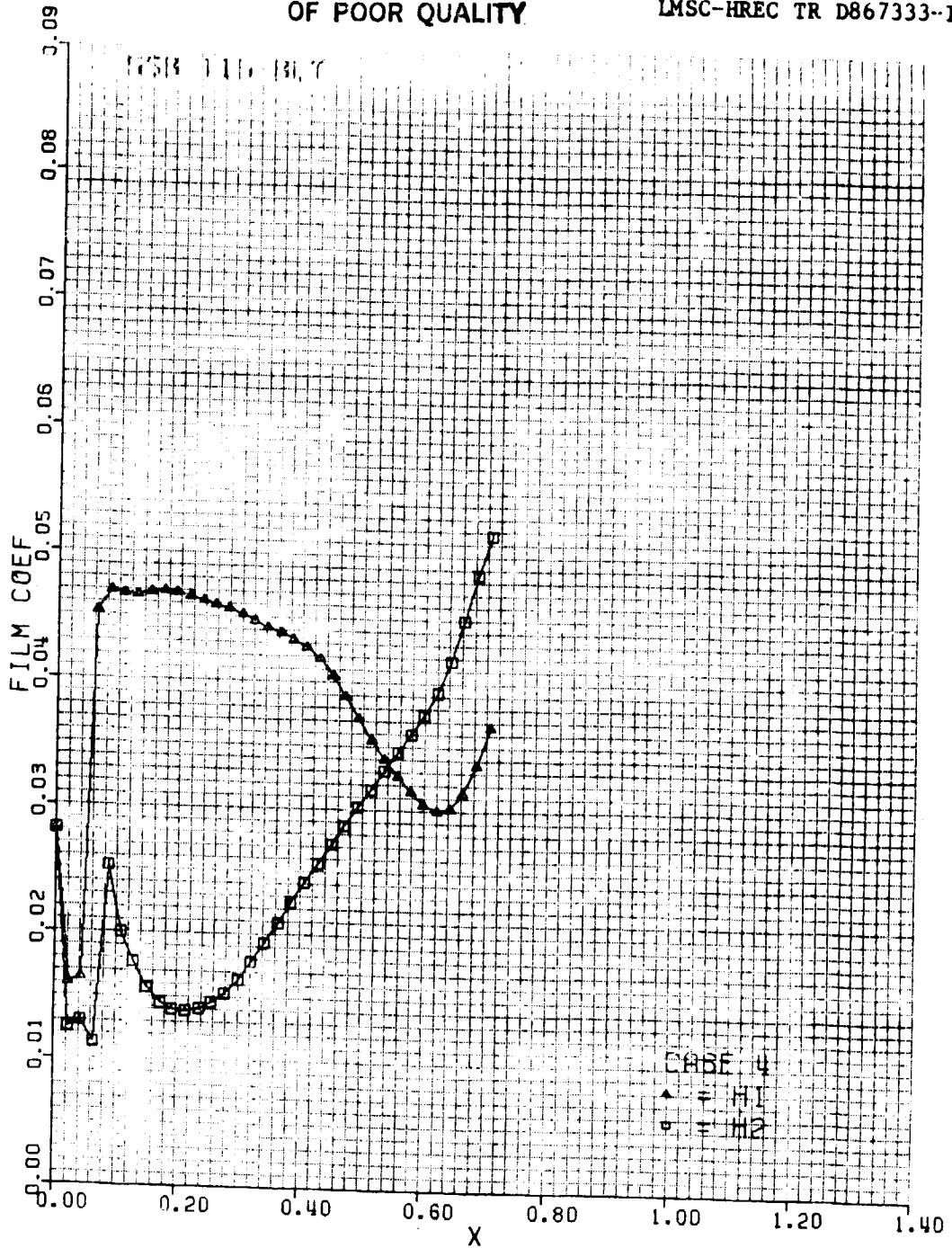

C.4.4

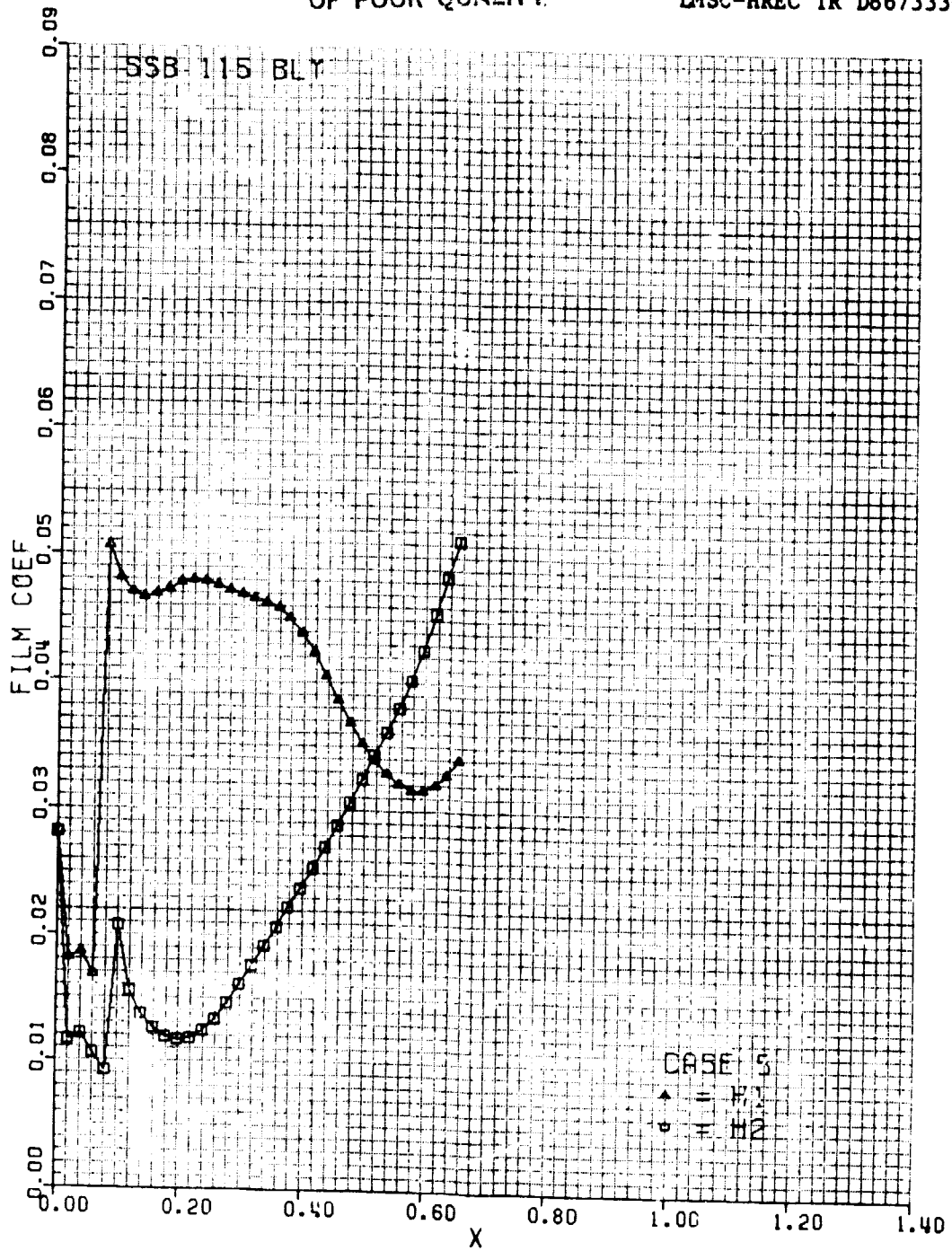

C.4.5

Appendix D

HPFTP SECOND STAGE NOZZLE PRESSURE, ADIABATIC WALL
TEMPERATURE AND HEAT TRANSFER
COEFFICIENT DISTRIBUTIONS

- D.1 FPL Pressure Distributions
- D.2 115 Percent Power Level Pressure Distributions
- D.3 FPL Heat Transfer Coefficients
- D.4 115 Percent Power Level Heat Transfer Coefficients

Surface 1 - Pressure Surface \triangle
Surface 2 - Suction Surface \square

Approximate Adiabatic Wall
Temperatures (F)

	FPL	115 Percent
Case 1 - R = 4.55 Hub	1445	1400
Case 2 - R = 4.76 Intermediate	↓	↓
Case 3 - R = 5.037 Mean		
Case 4 - R = 5.25 Intermediate	↓	↓
Case 5 - R = 5.523 Tip		

ORIGINAL PAGE IS
OF POOR QUALITY

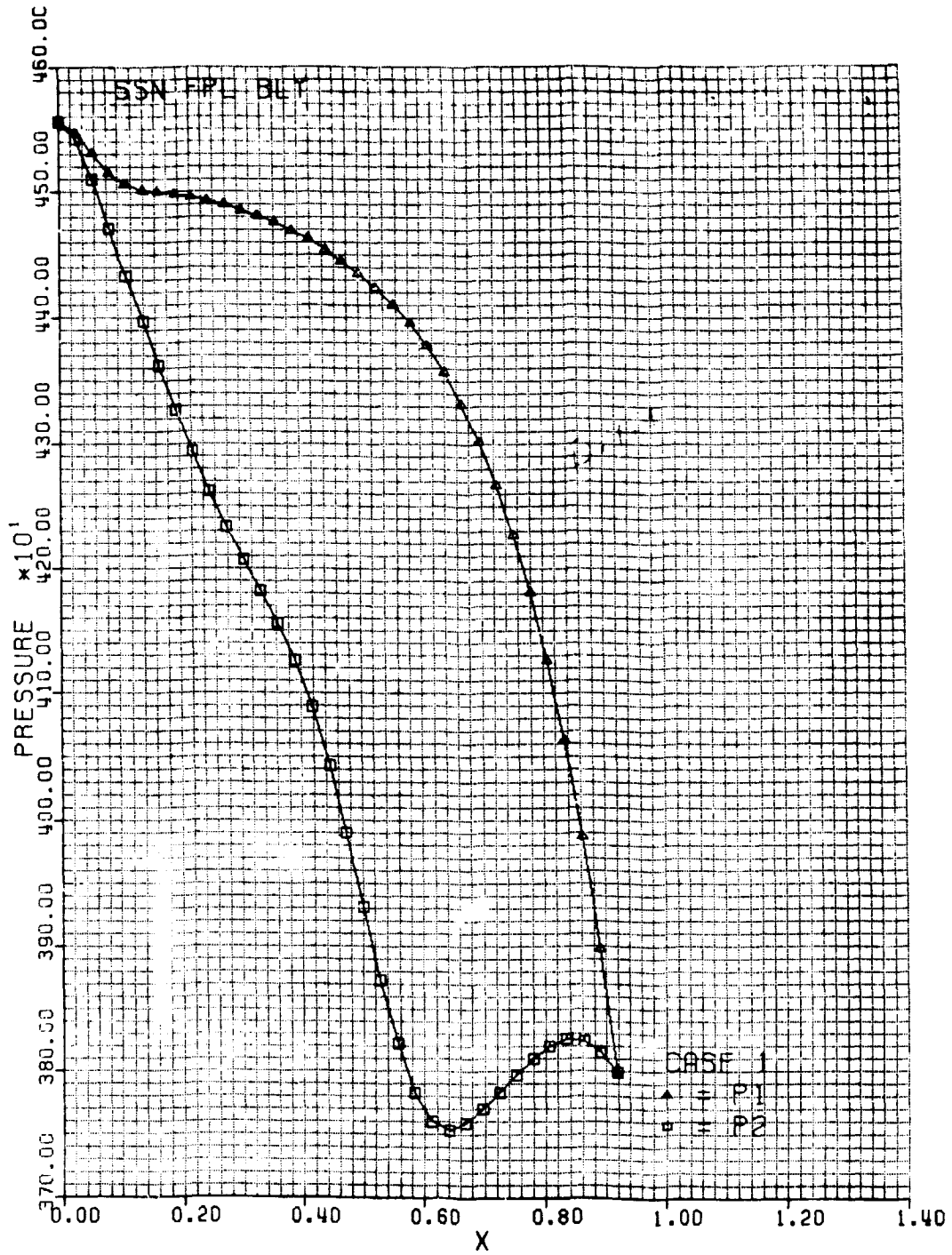

C-2

D.1.1

ORIGINAL PAGE IS
OF POOR QUALITY

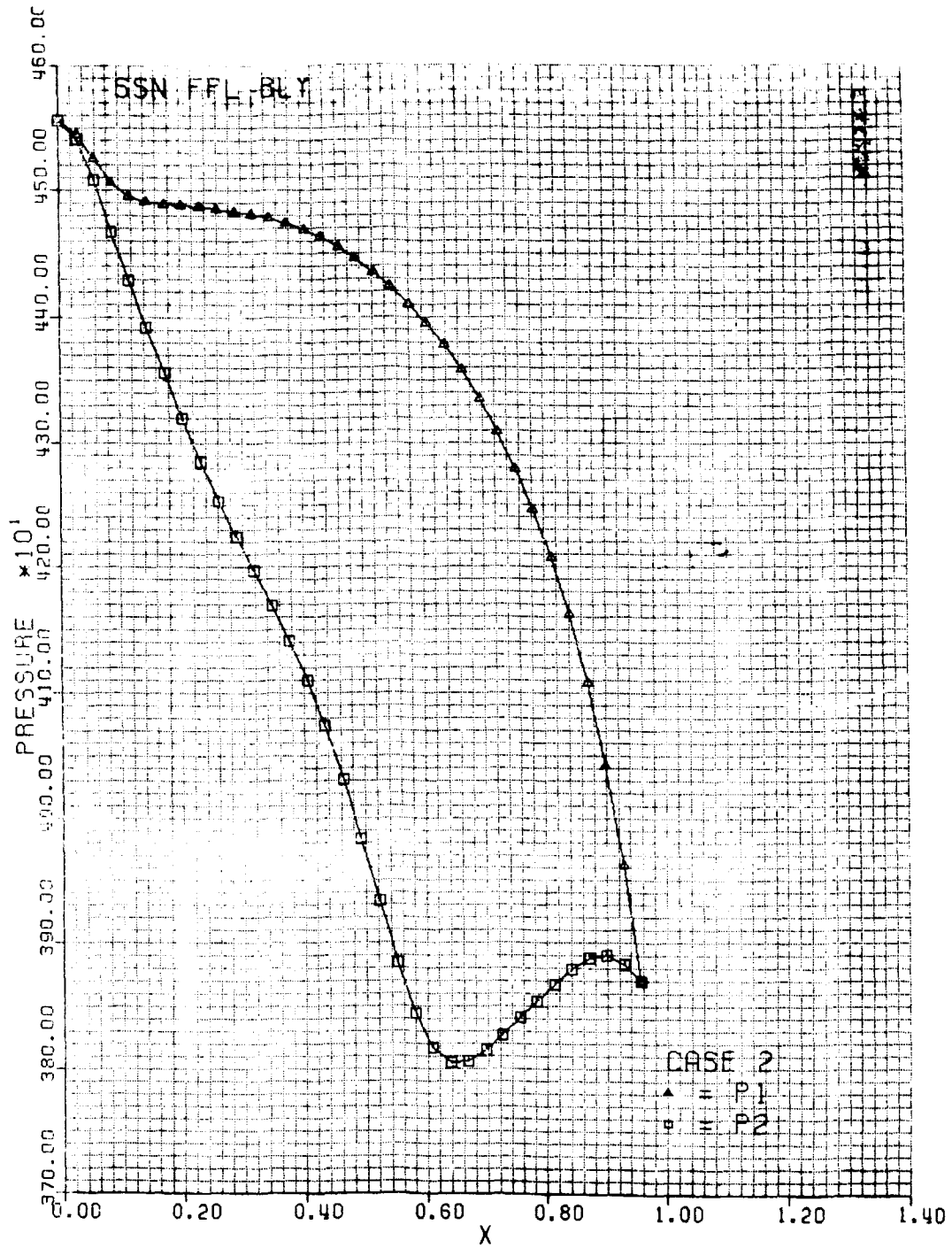

D.1.2

ORIGINAL PAGE IS
OF POOR QUALITY

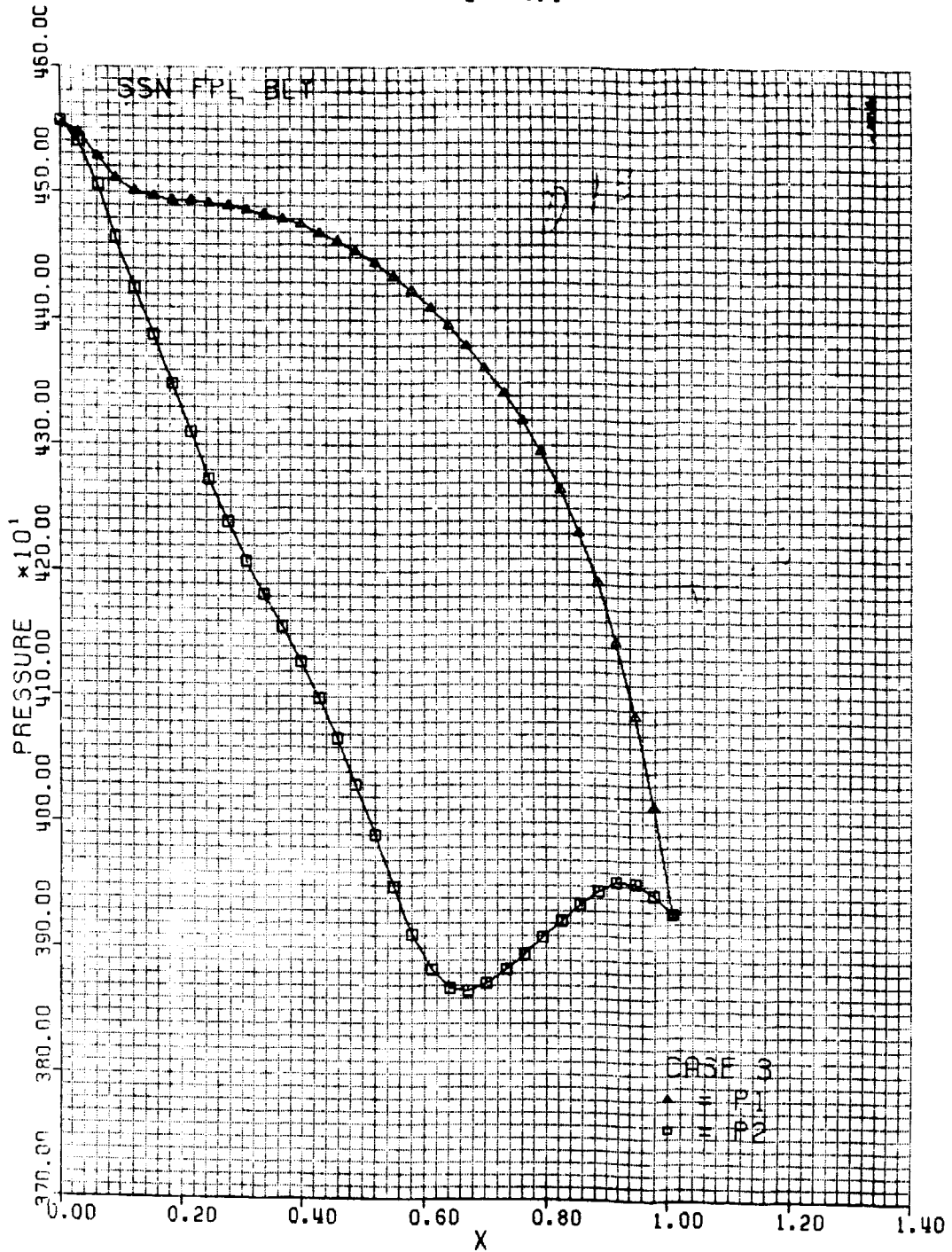

D.1.3

ORIGINAL PAGE IS
OF POOR QUALITY

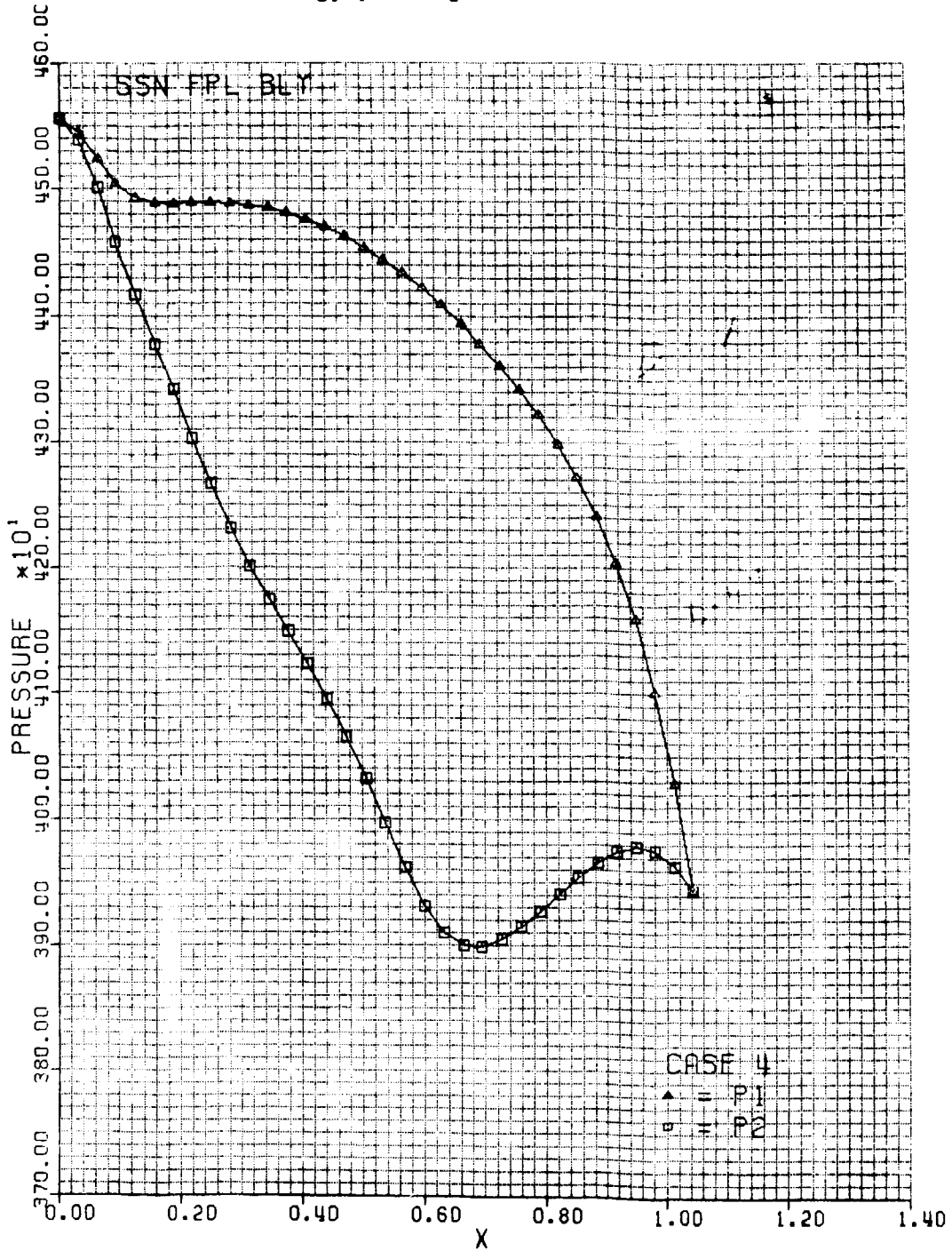

D.1.4

ORIGINAL PAGE IS
OF POOR QUALITY

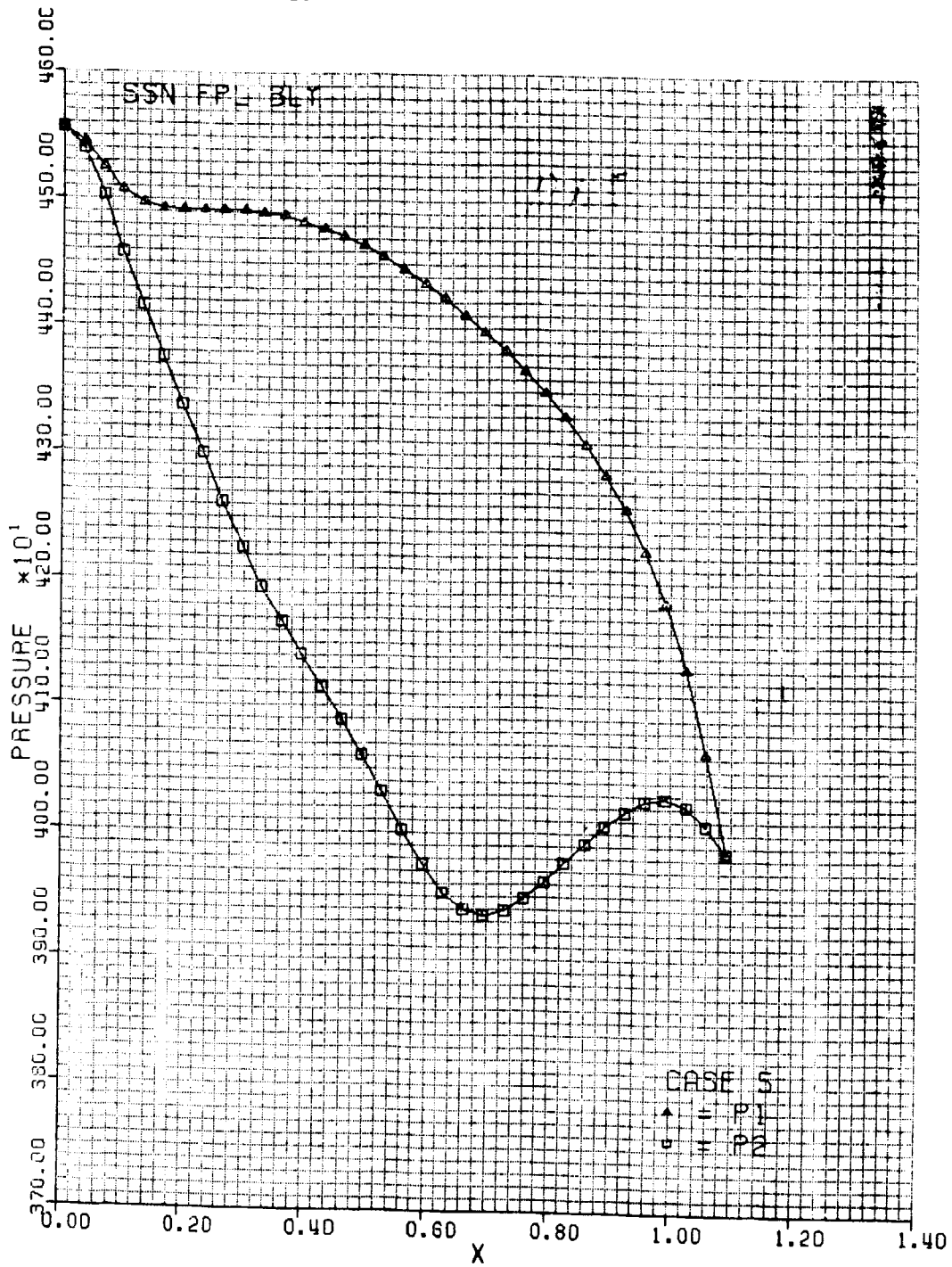

D.1.5

ORIGINAL PAGE IS
OF POOR QUALITY

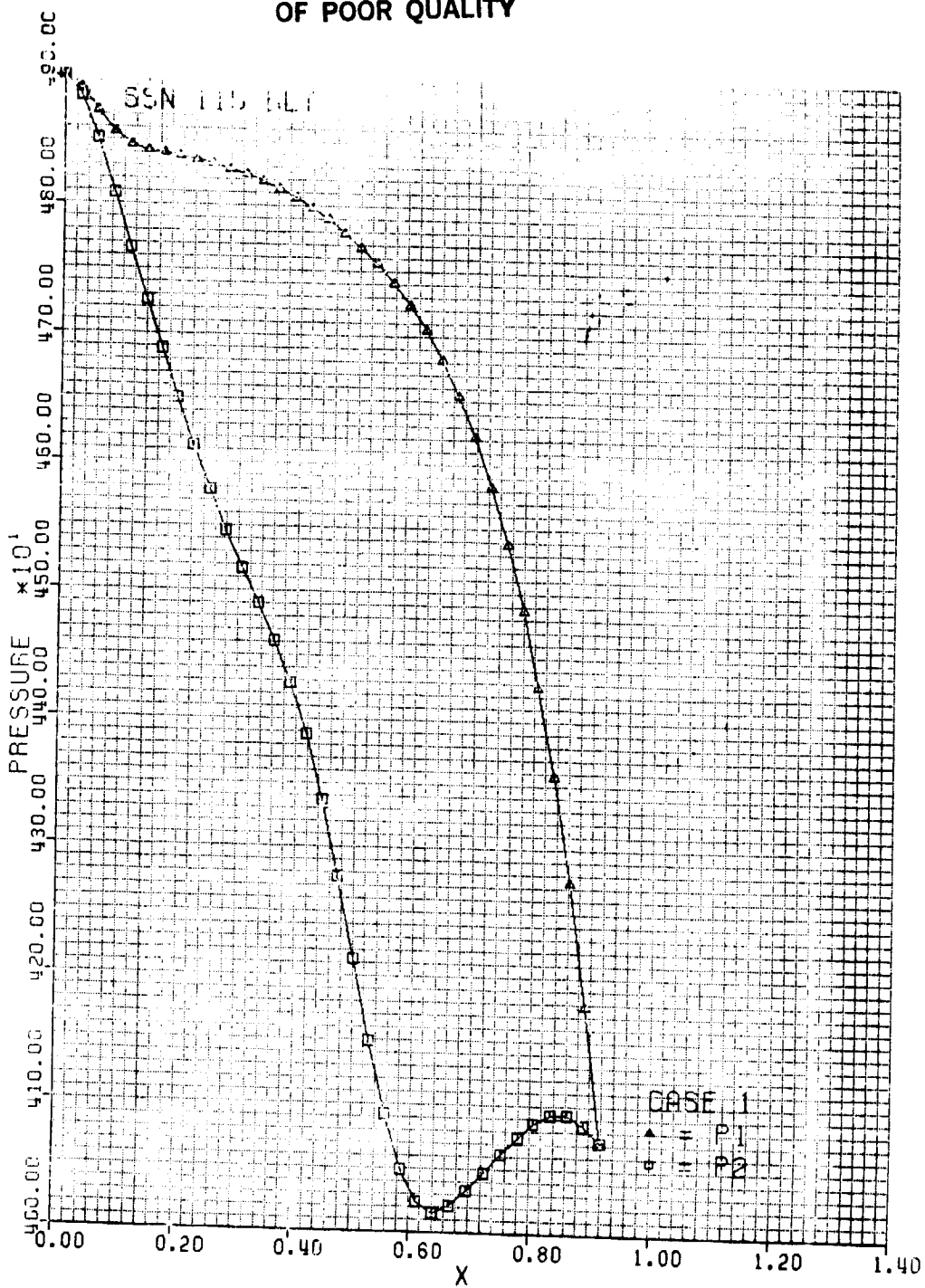

D.2.1

ORIGINAL PAGE IS
OF POOR QUALITY

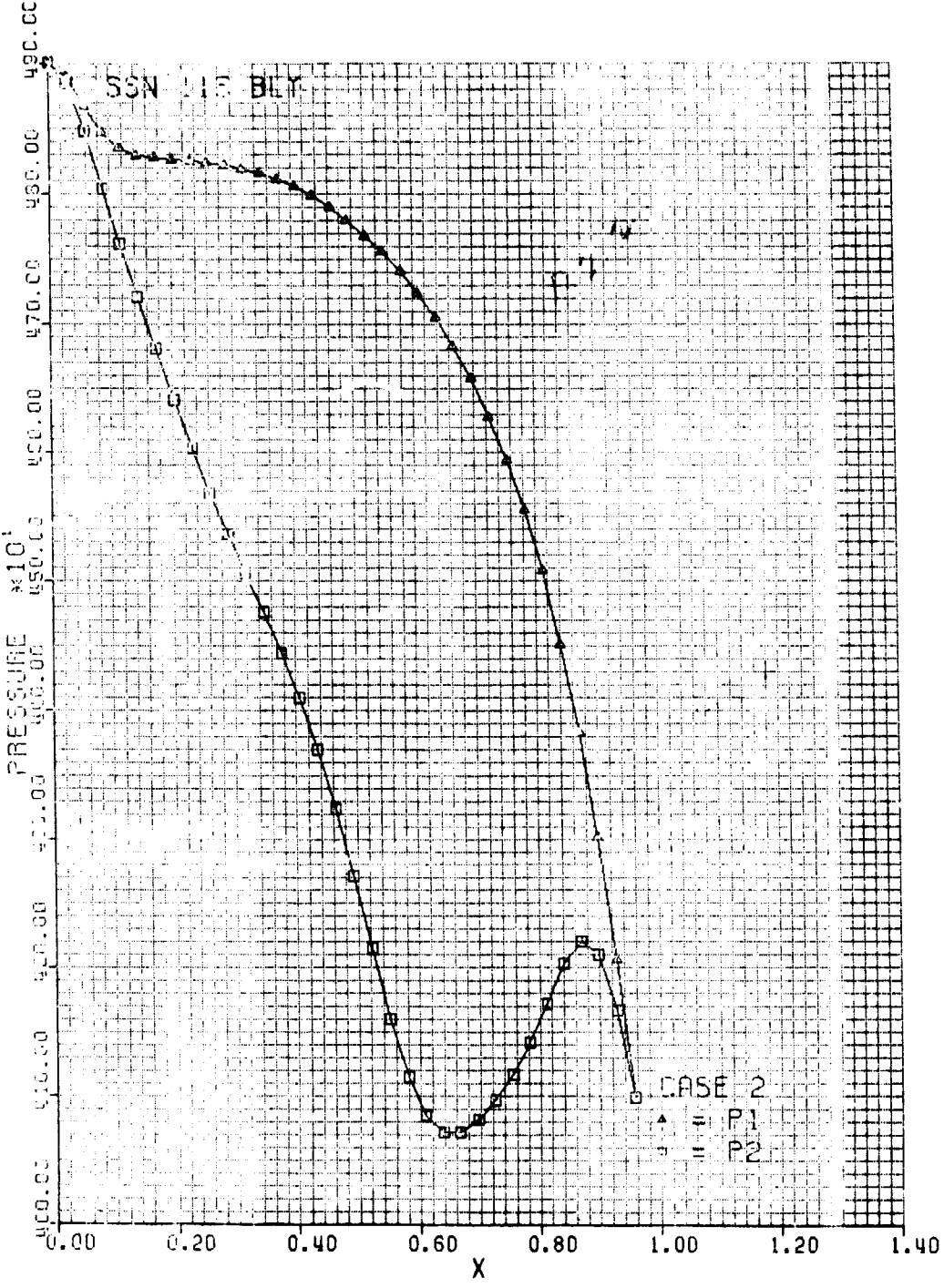

D.2.2

ORIGINAL PAGE IS
OF POOR QUALITY

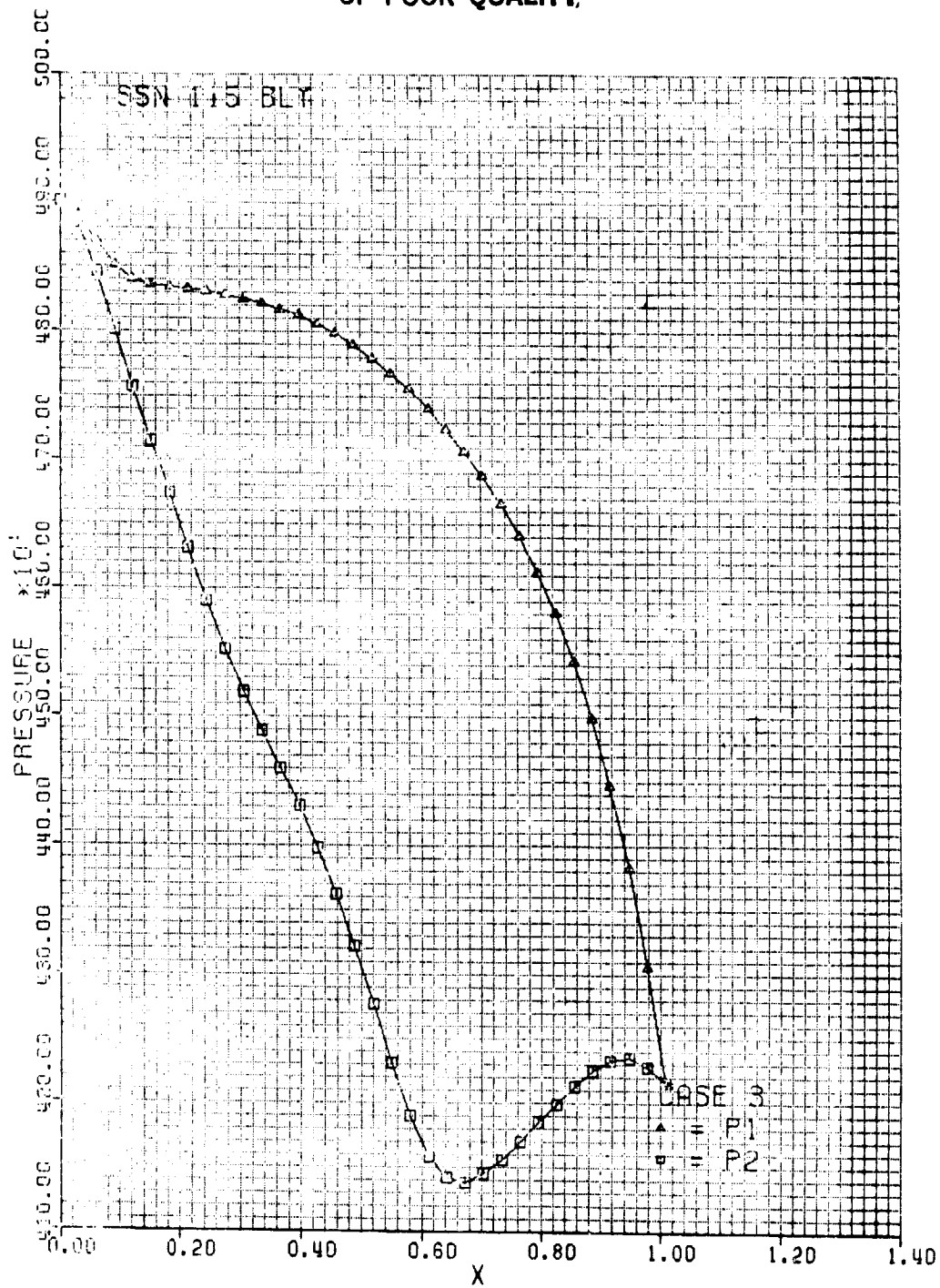

D.2.3

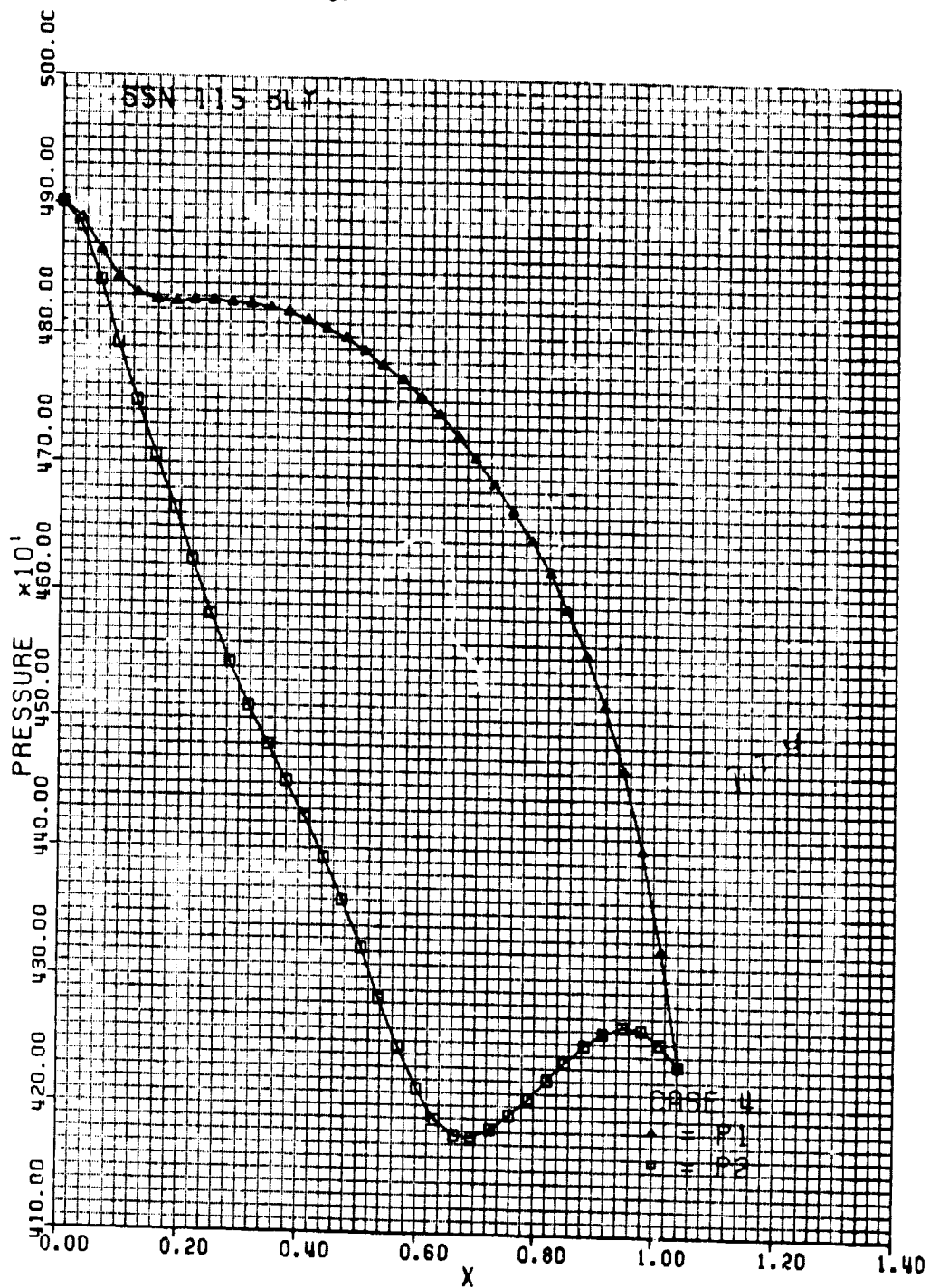

D.2.4

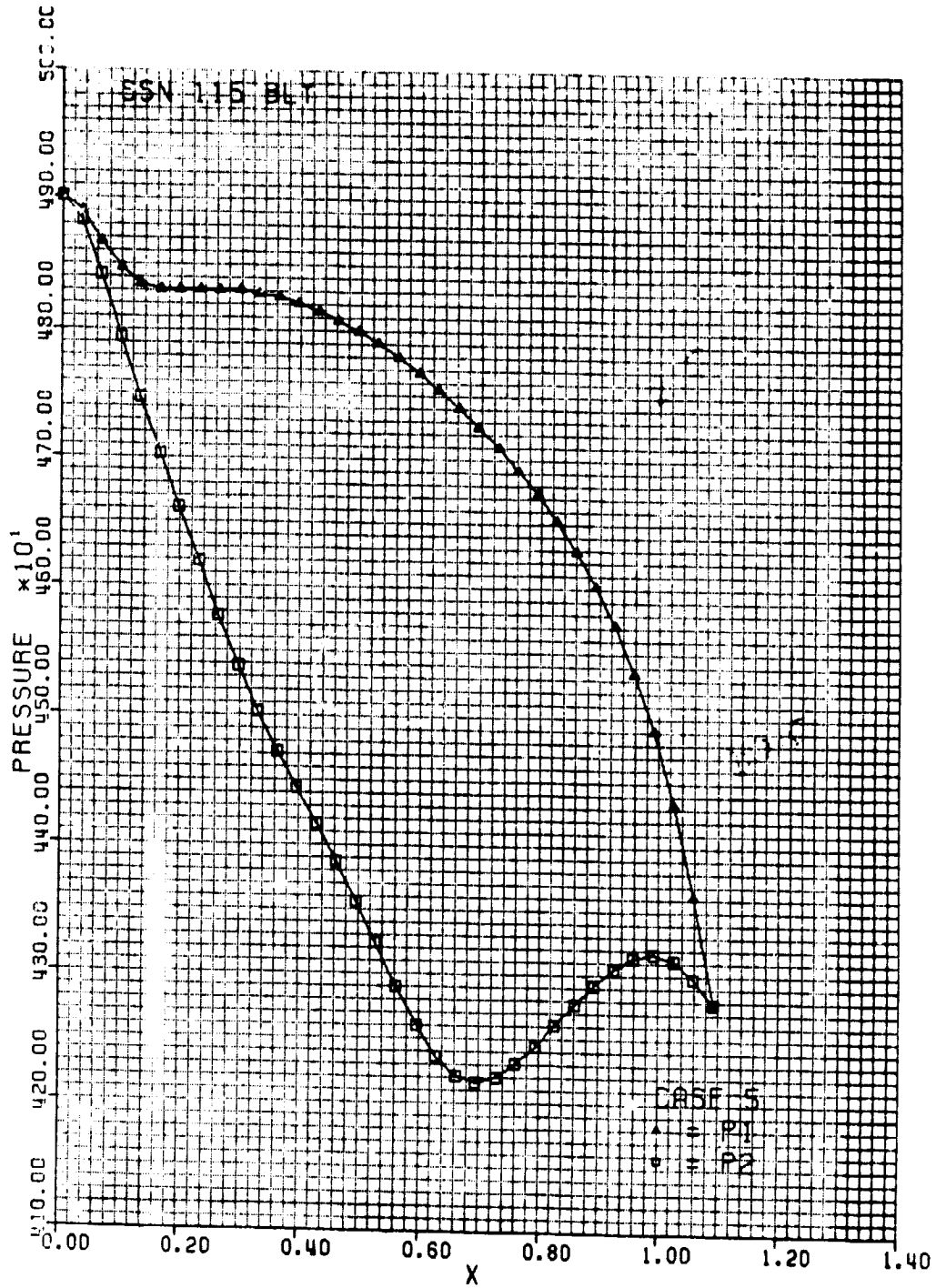

D.2.5

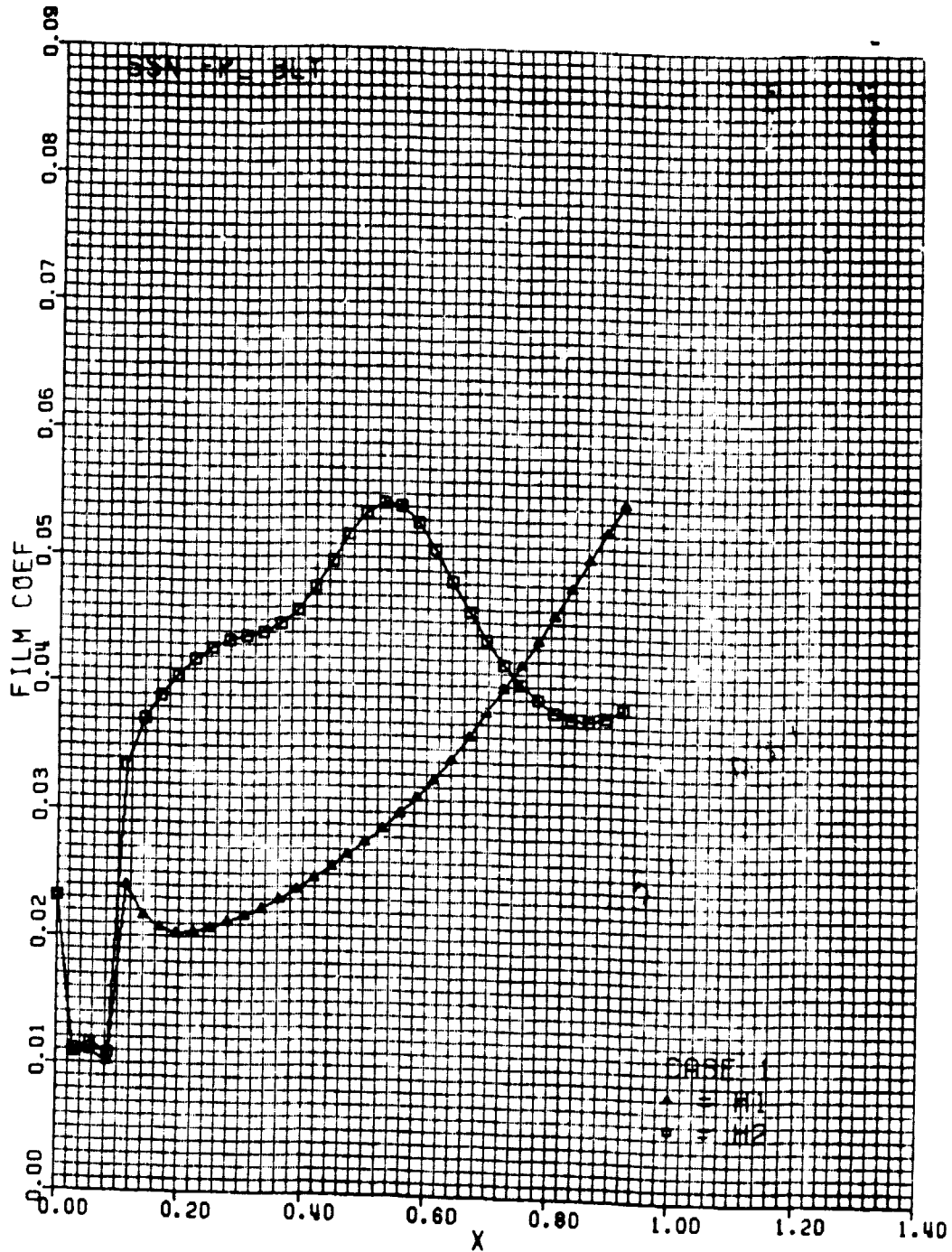

D.3.1

ORIGINAL PAGE IS
OF POOR QUALITY

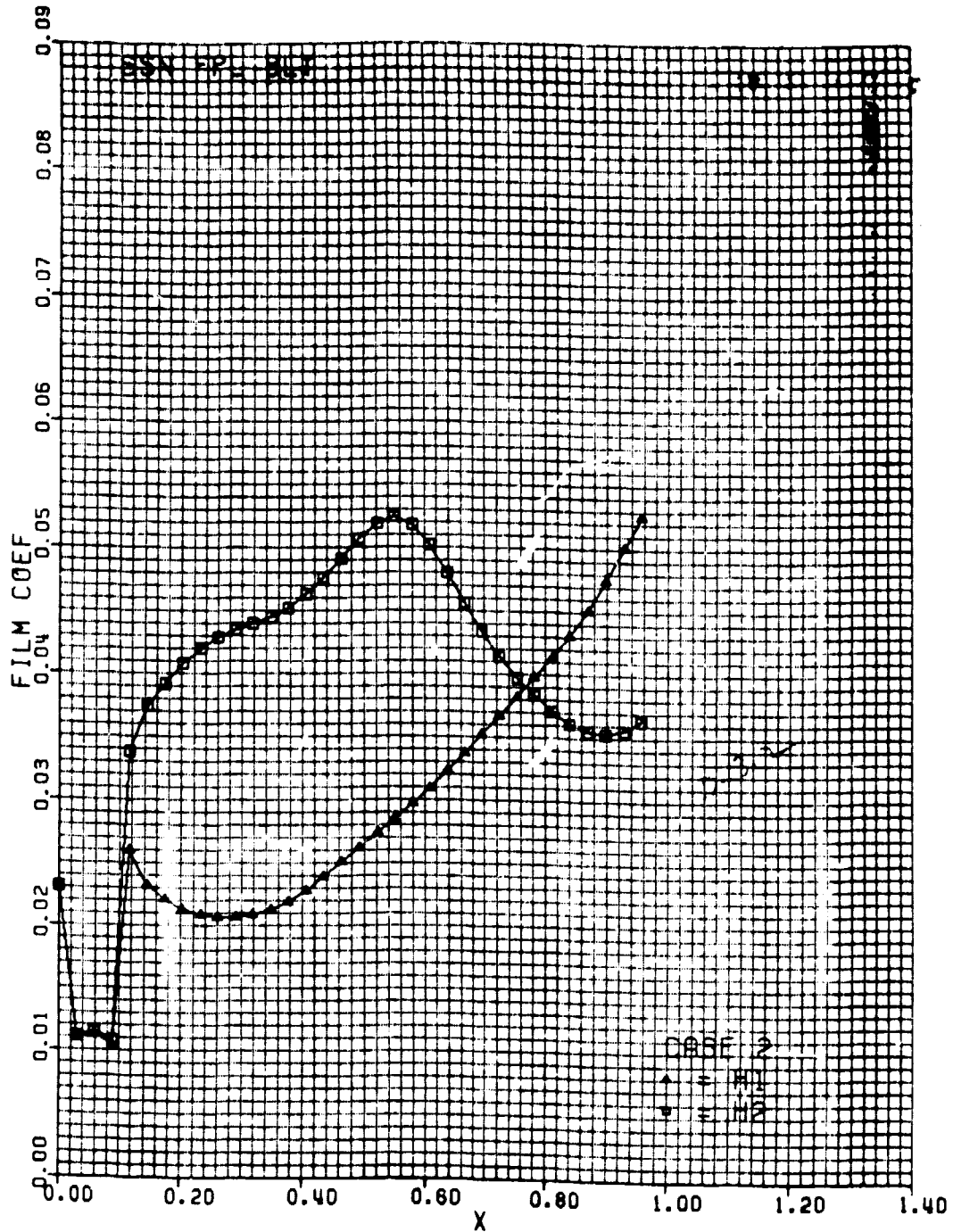

D.3.2

ORIGINAL PAGE 19
OF POOR QUALITY

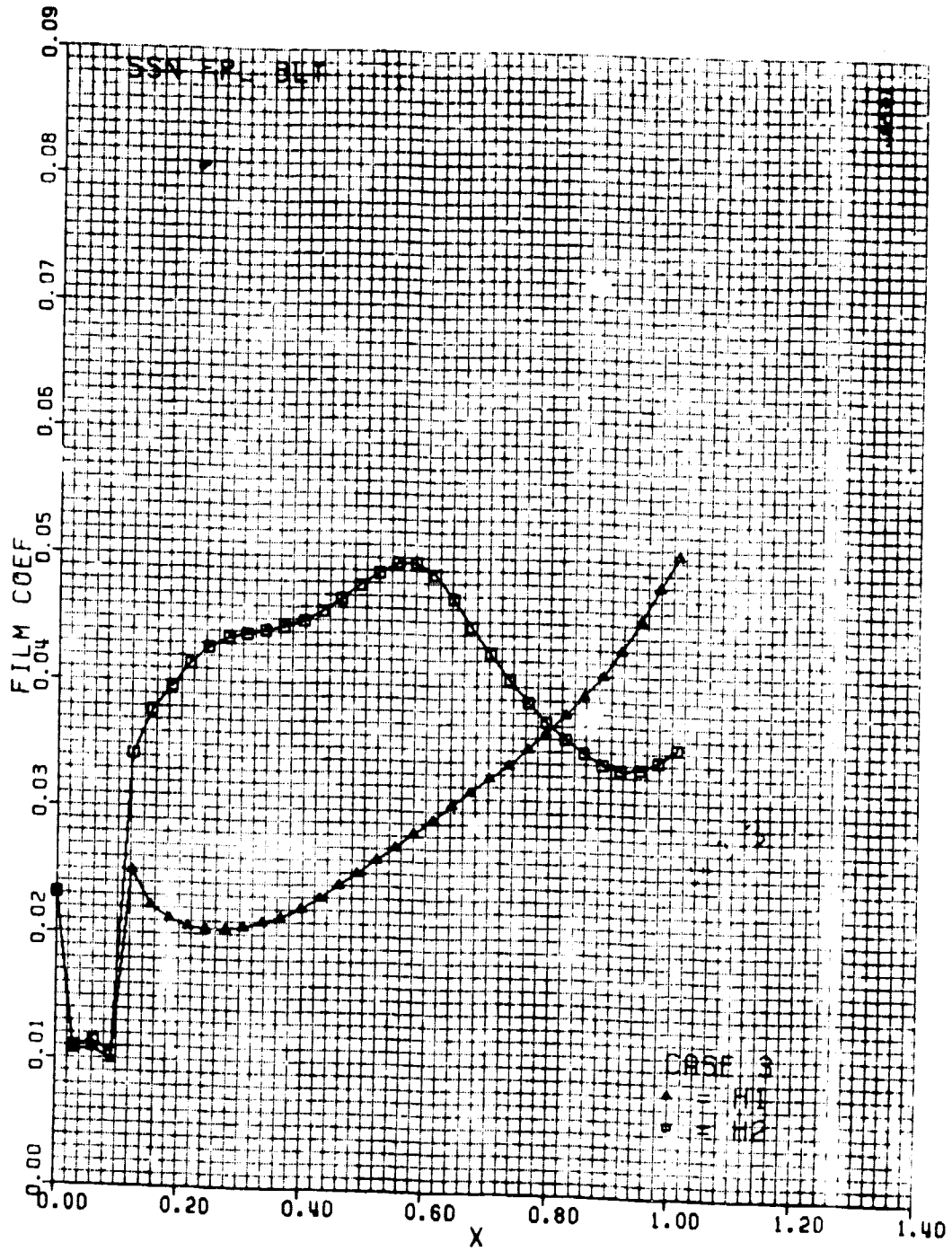

D.3.3

ORIGINAL PAGE IS
OF POOR QUALITY

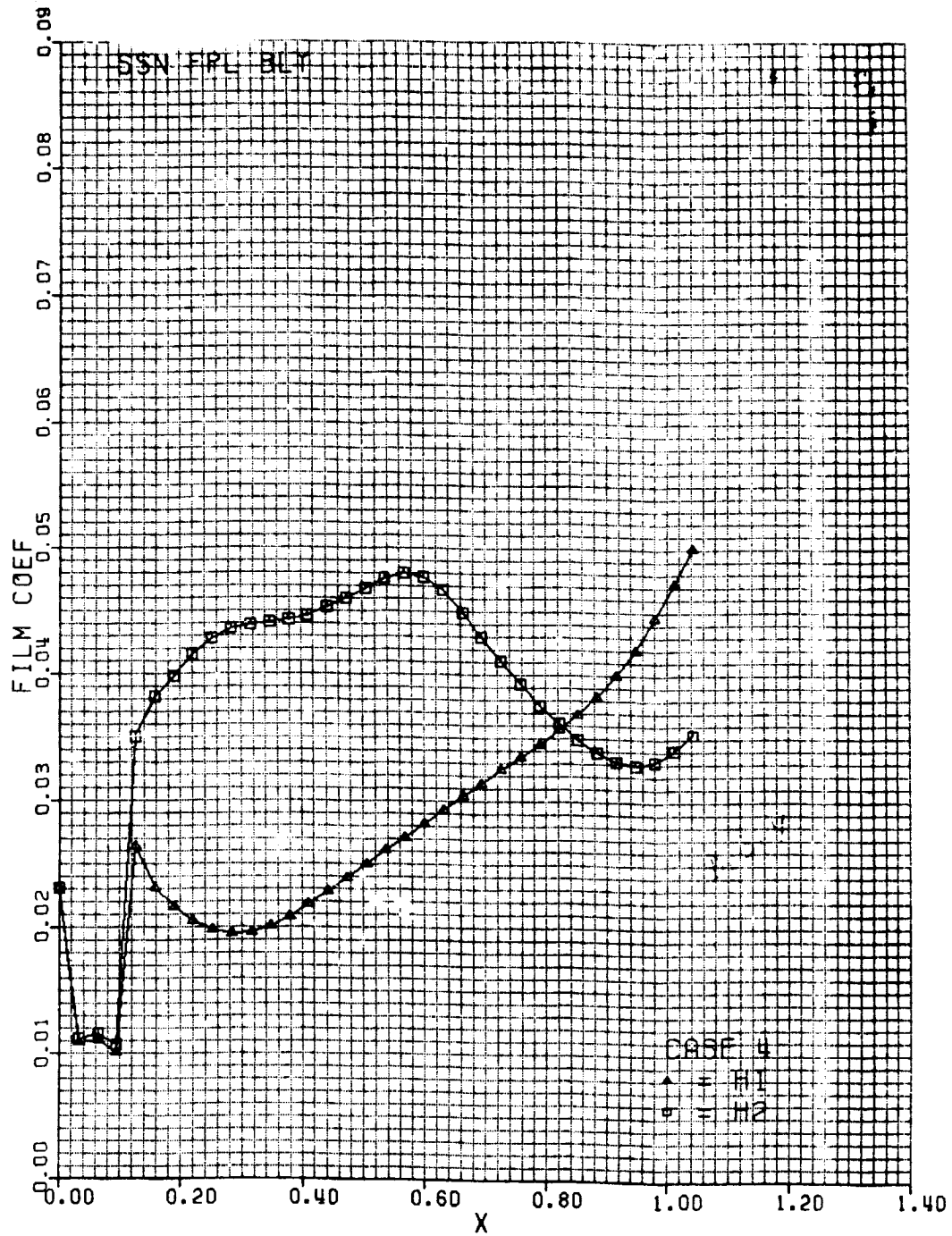

D.3.4

ORIGINAL PAGE IS
OF POOR QUALITY

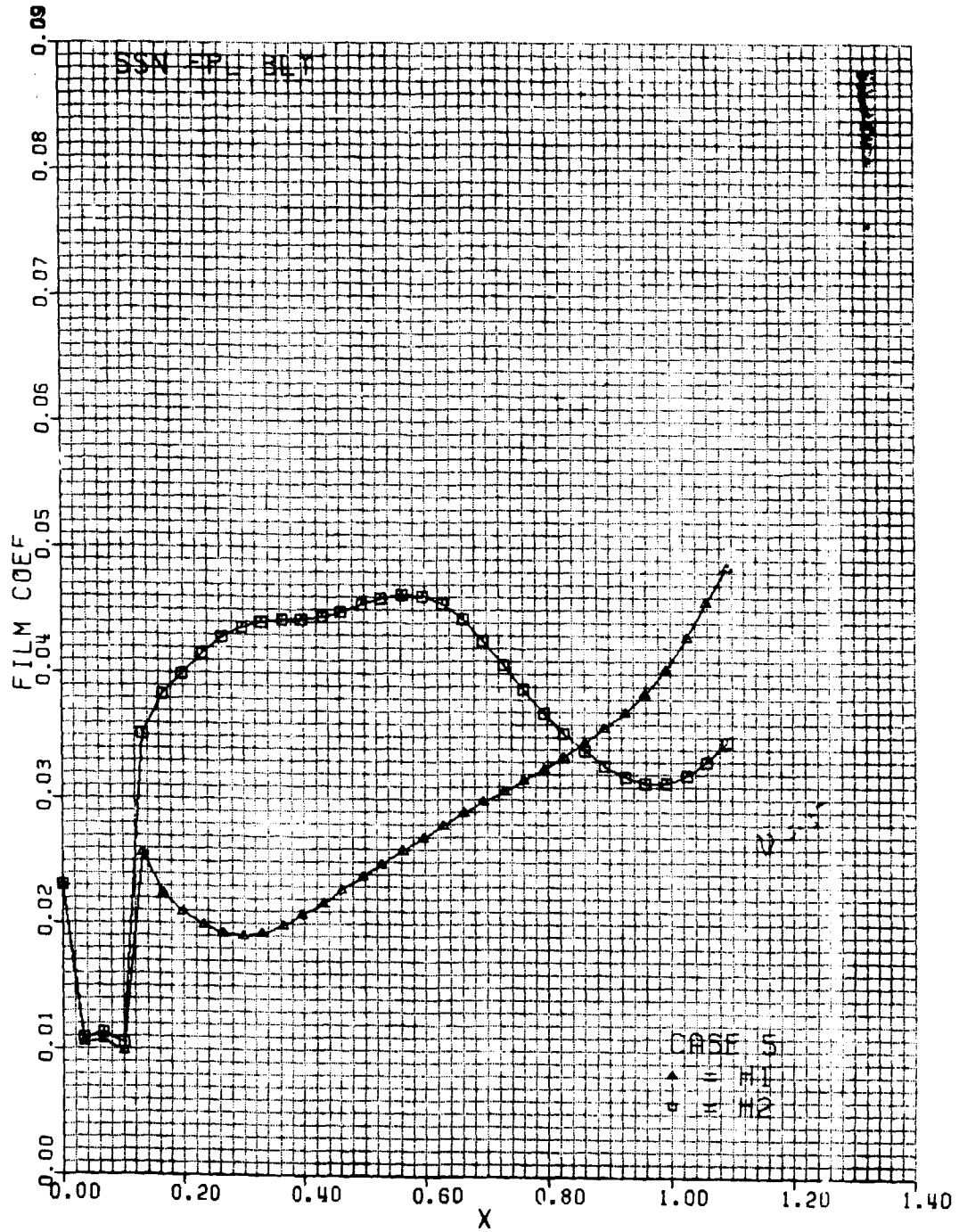

D.3.5

ORIGINAL PAGE IS
OF POOR QUALITY

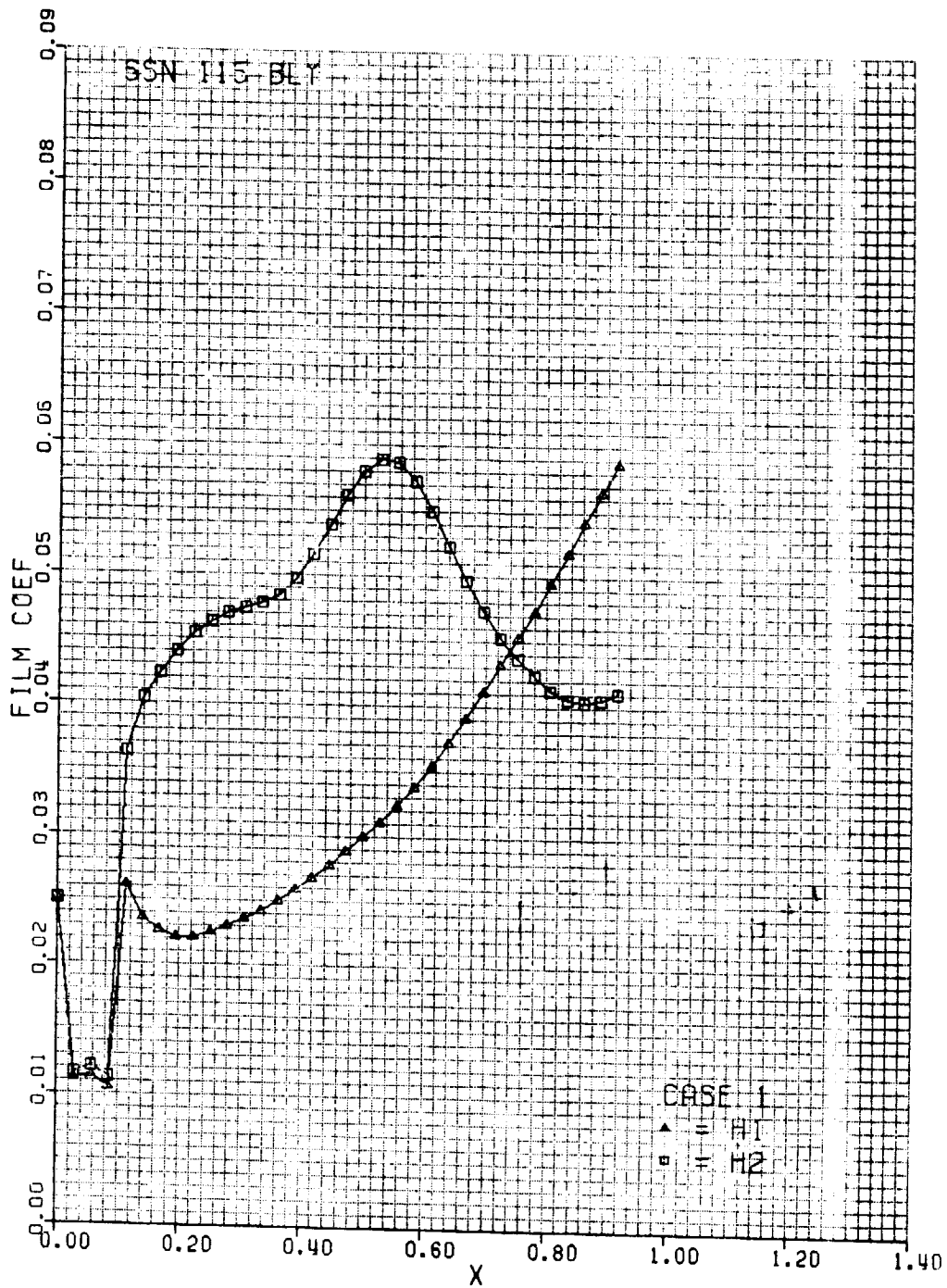

D.4.1

ORIGINAL PAGE IS
OF POOR QUALITY

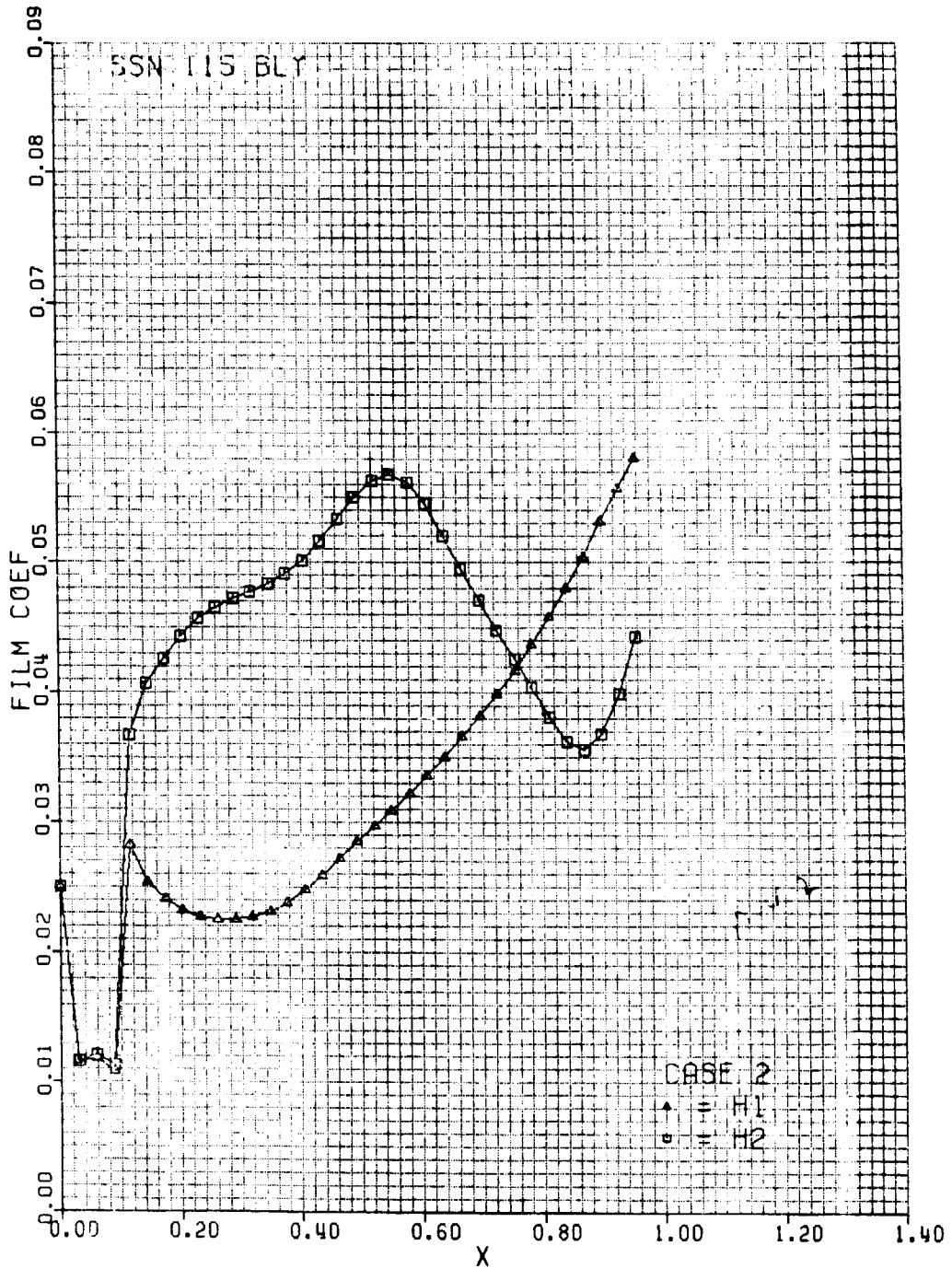

D.4.2

ORIGINAL PAGE IS
OF POOR QUALITY

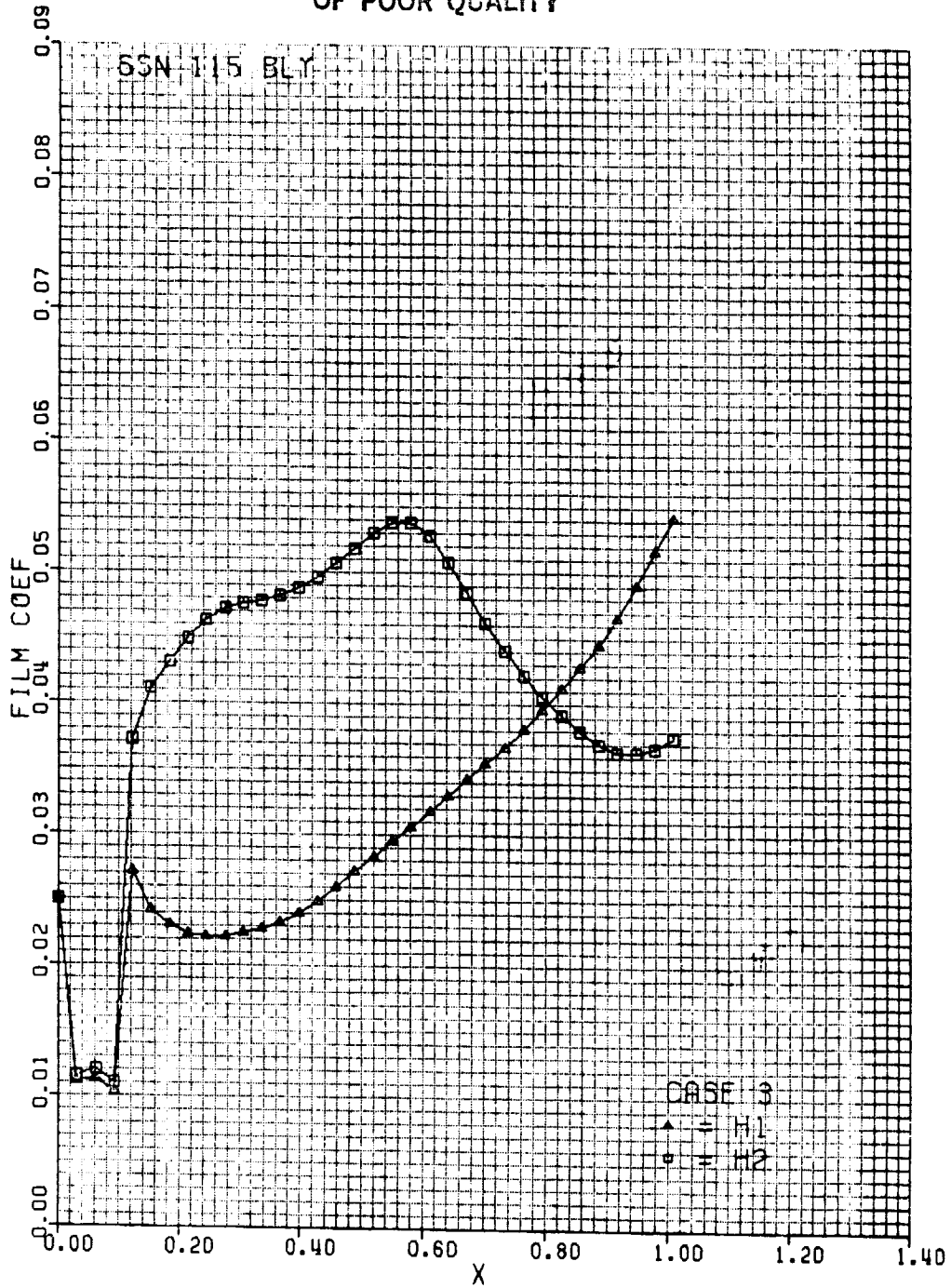

D.4.3

ORIGINAL POINTS
OF POOR QUALITY

LMSC-HREC TR D867333-1

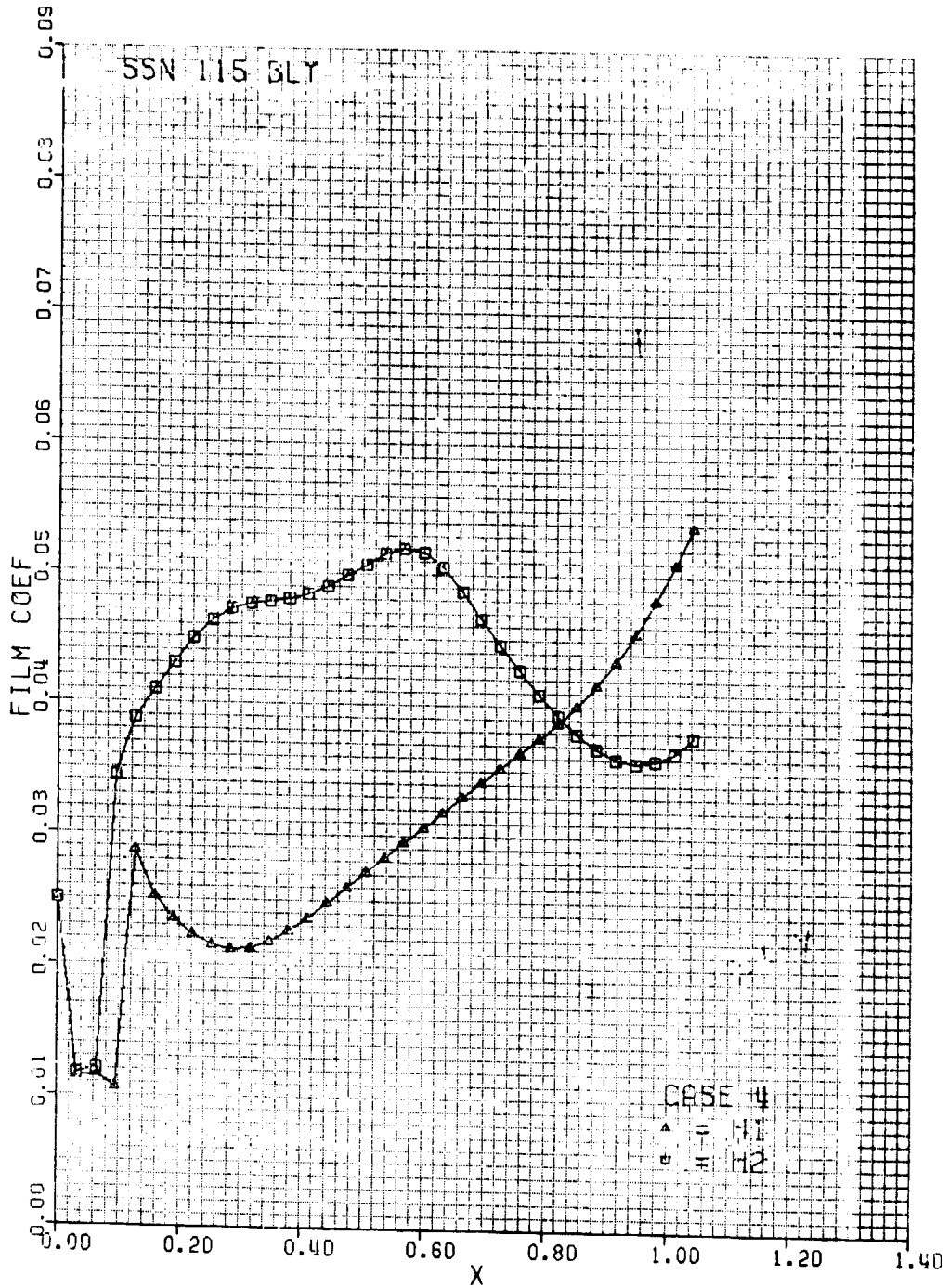

D.4.4

LOCKHEED-HUNTSVILLE RESEARCH & ENGINEERING CENTER

ORIGINAL PAGE IS
OF POOR QUALITY

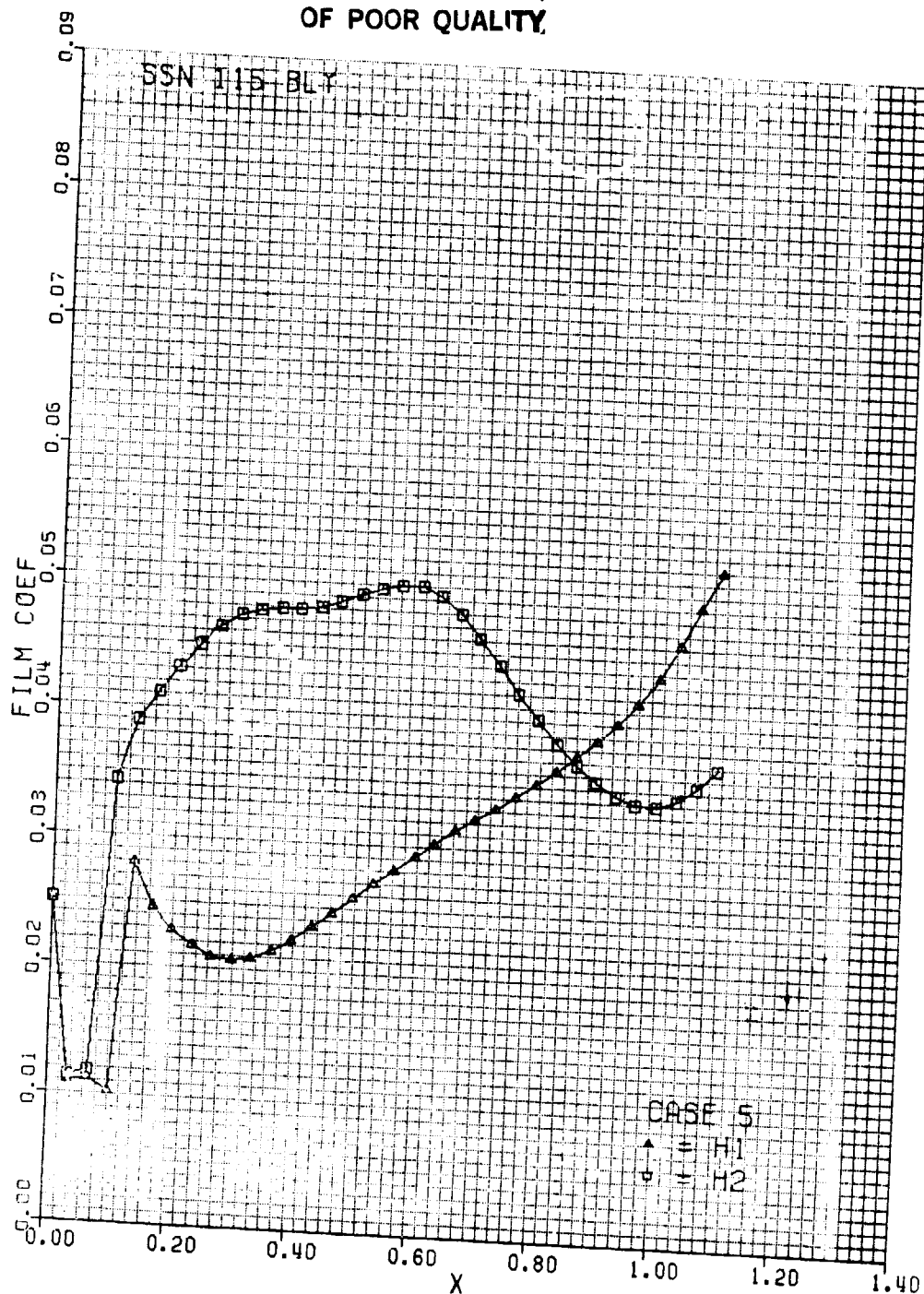

D.4.5

Appendix E

HPOTP FIRST STAGE NOZZLE PRESSURE, ADIABATIC WALL TEMPERATURE
AND HEAT TRANSFER COEFFICIENT DISTRIBUTIONS

- E.1 FPL Pressure Distributions
- E.2 115 Percent Power Level Pressure Distributions
- E.3 FPL Heat Transfer Coefficients
- E.4 115 Percent Power Level Heat Transfer Coefficients

Surface 1 - Suction Surface \triangle
Surface 2 - Pressure Surface \square

Approximate Adiabatic Wall
Temperatures (F)

	FPL	Percent
Streamline 1 - R = 4.795	1030	1215
Streamline 6 - R = 5.04	1030	1215
Streamline 11 - R = 5.285	1030	1215

ORIGINAL PAGE IS
OF POOR QUALITY

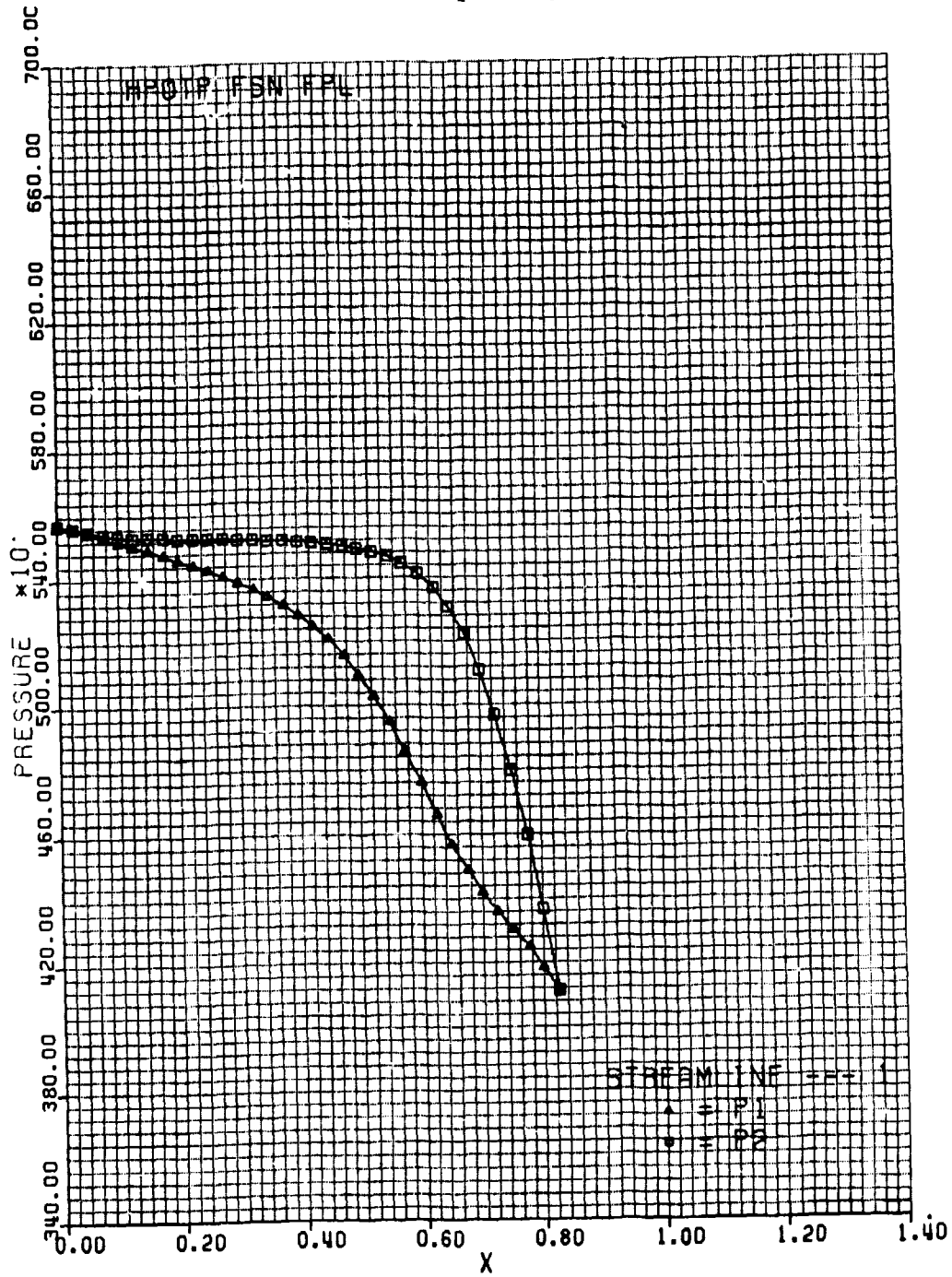

E.1.1

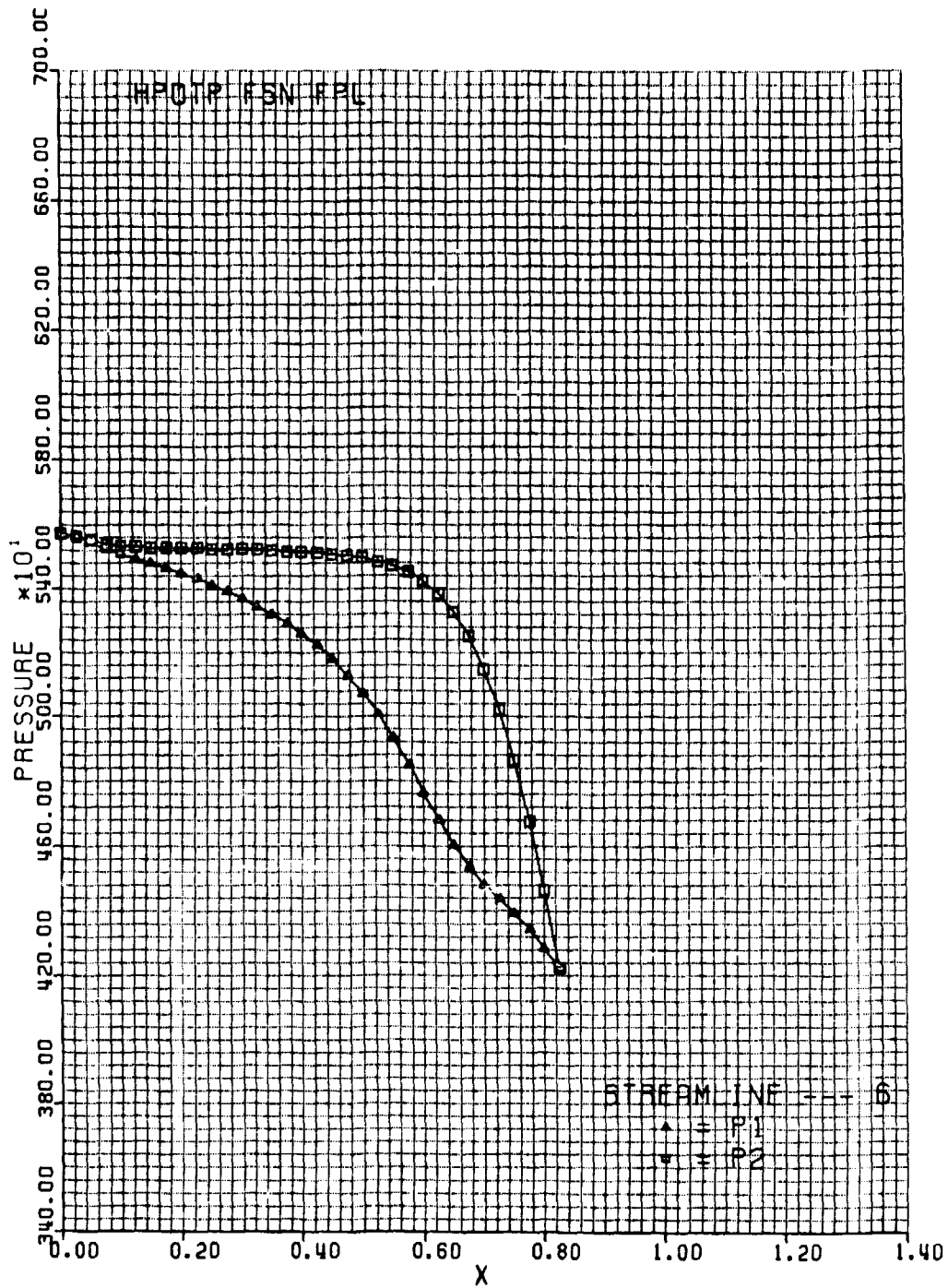

ORIGINAL PAGE IS
OF POOR QUALITY

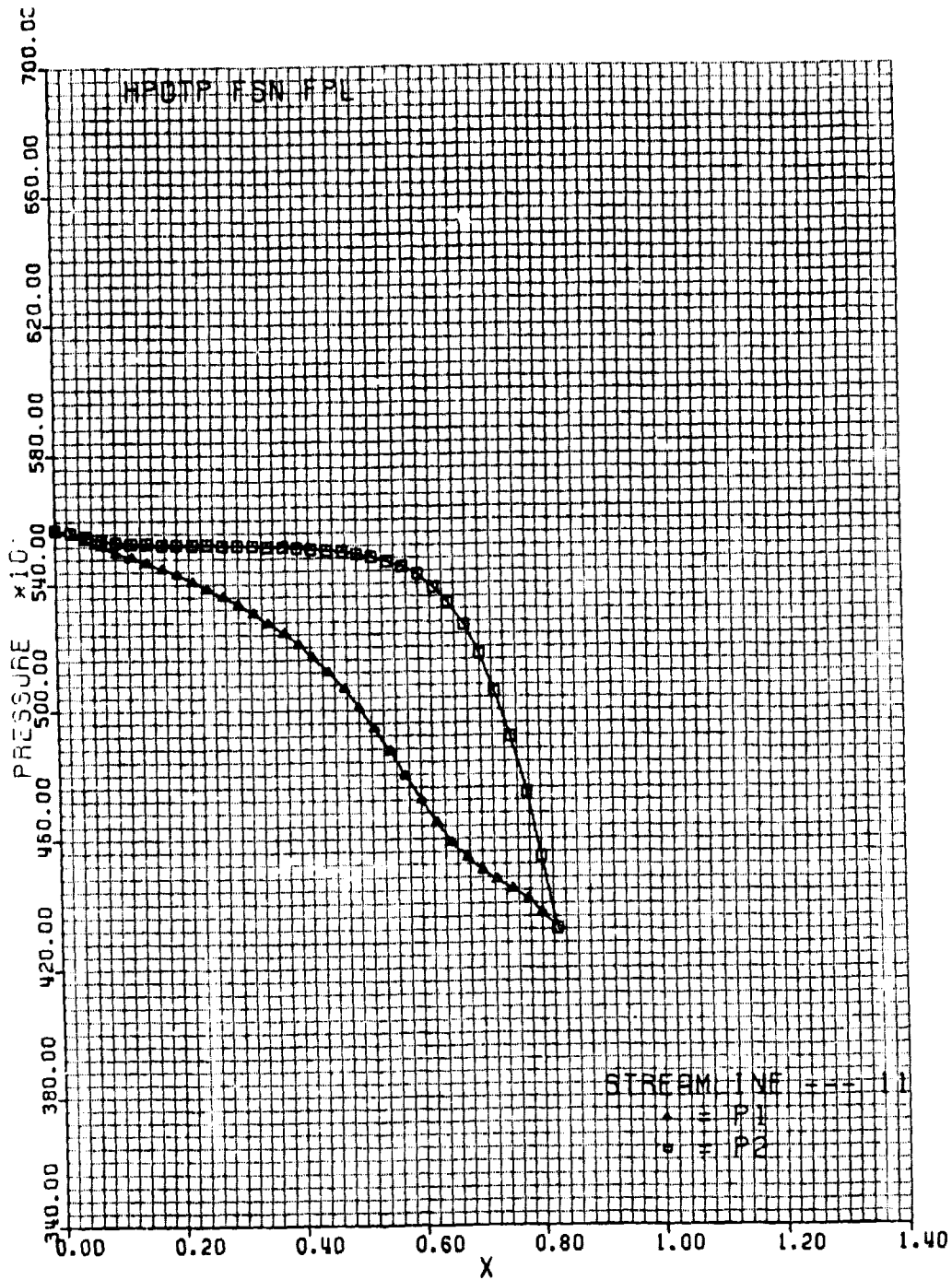

E.1.3

ORIGINAL PAGE IS
OF POOR QUALITY

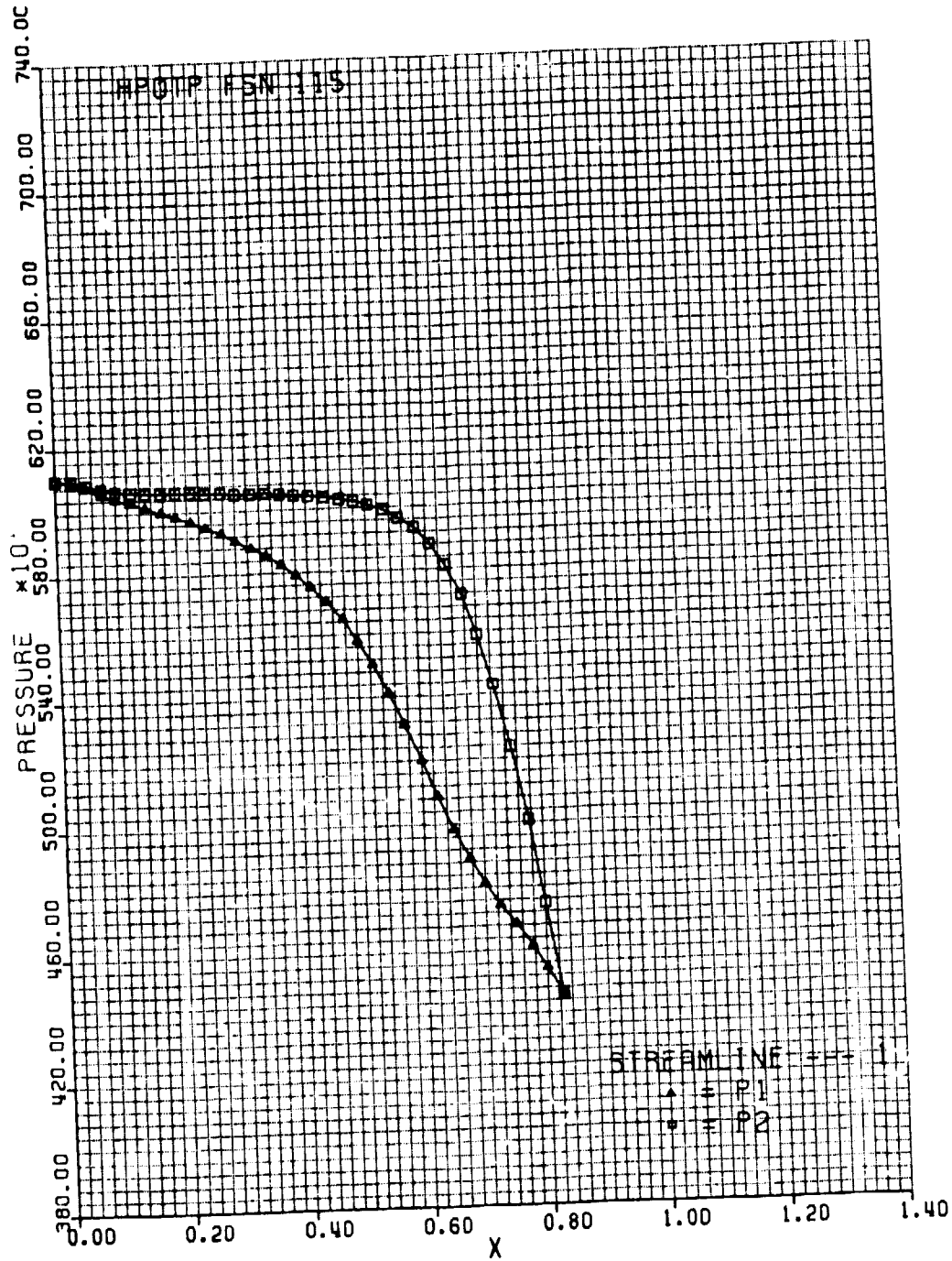

E.2.1

ORIGINAL PAGE IS
OF POOR QUALITY

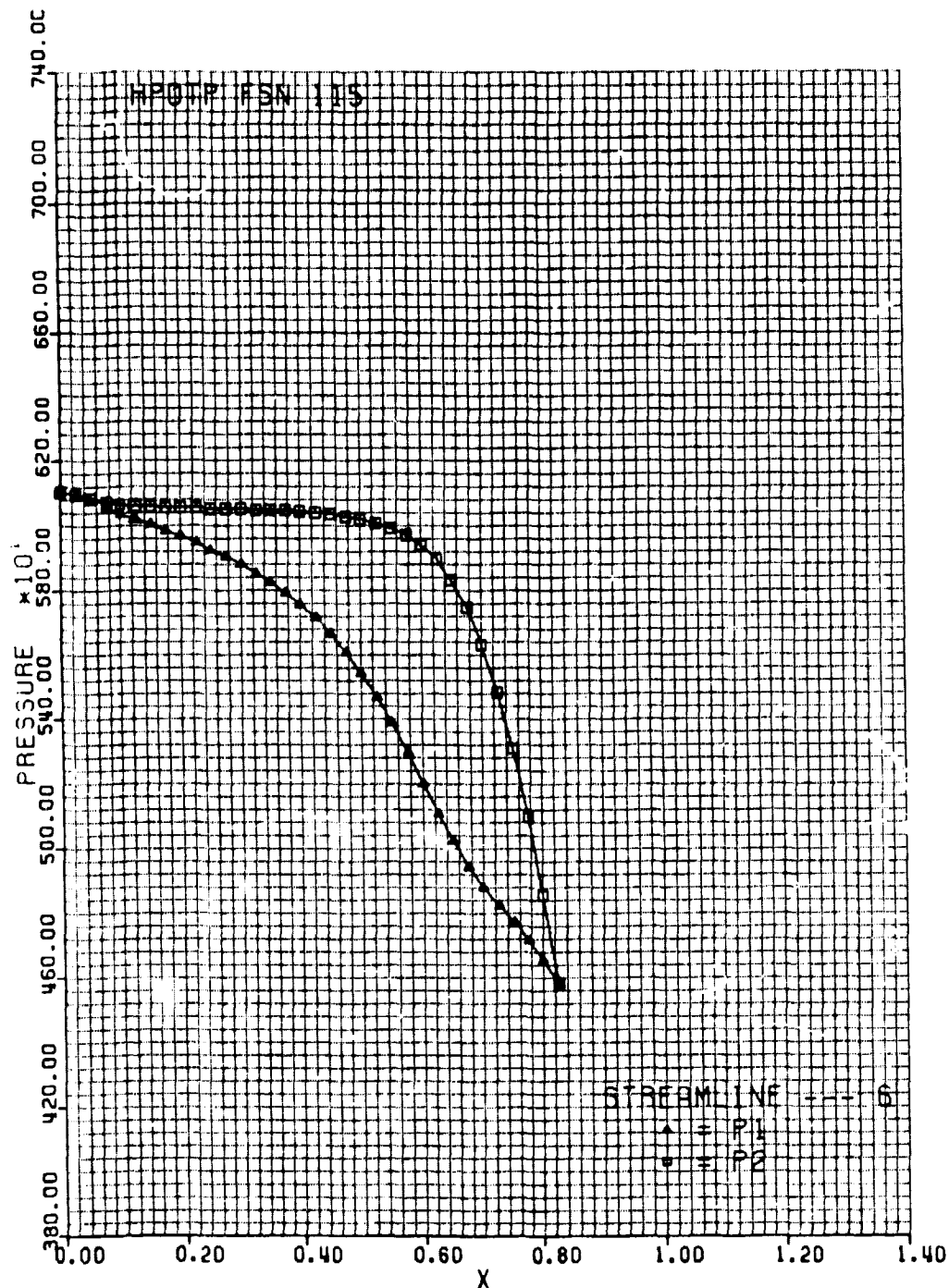

E. 2. 2

ORIGINAL PAGE IS
OF POOR QUALITY.

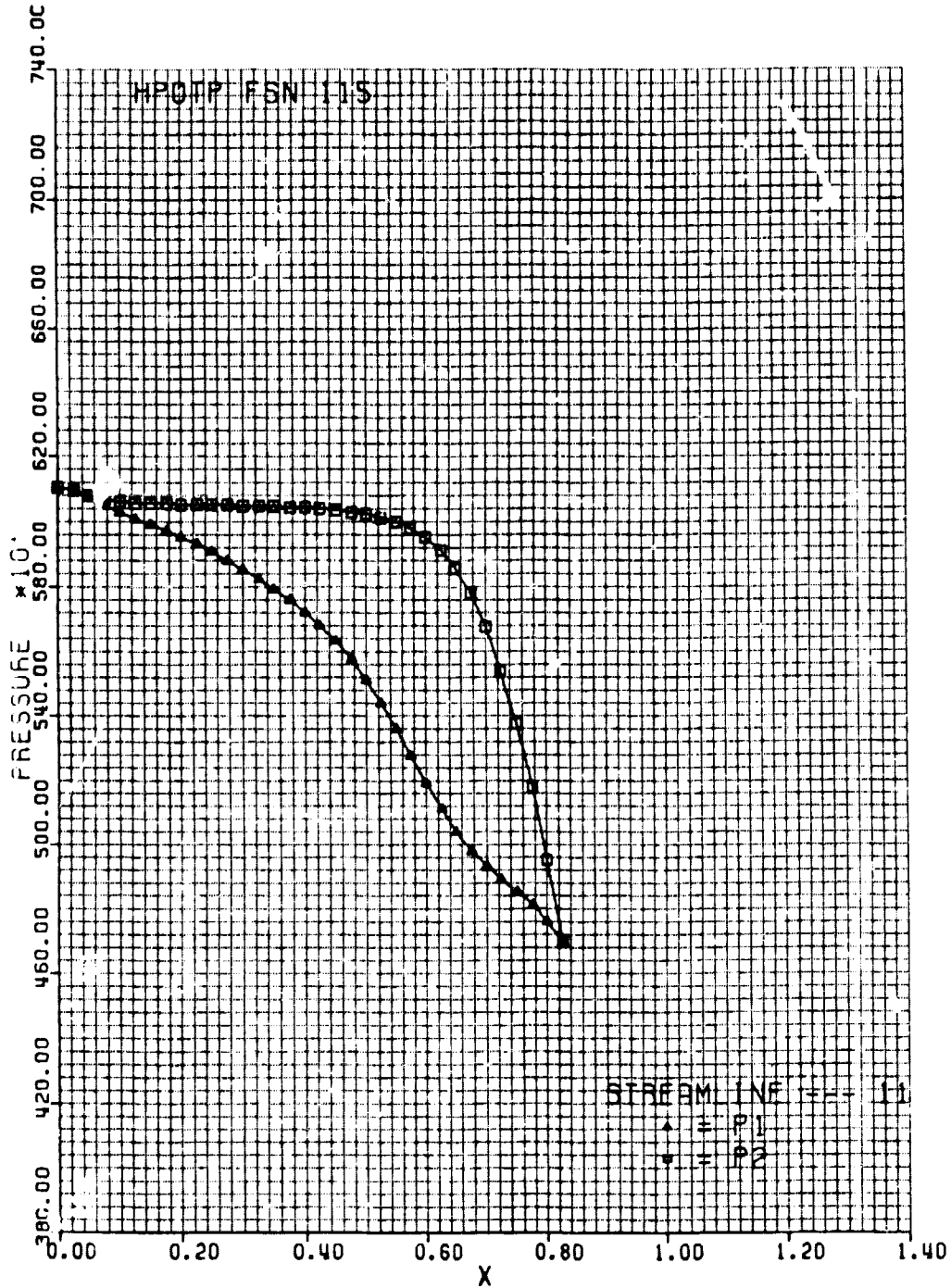

E.2.3

ORIGINAL PAGE 13
OF POOR QUALITY

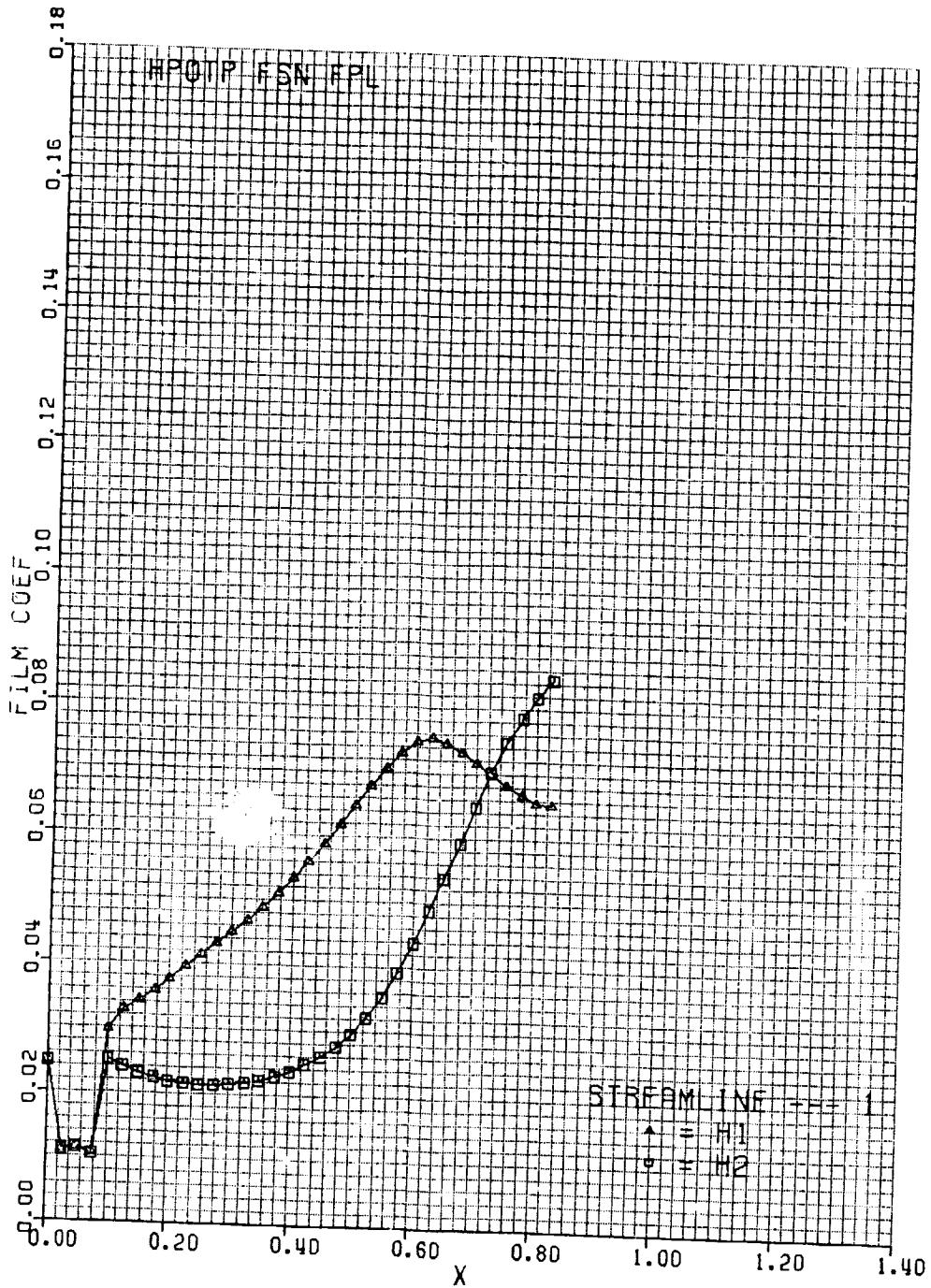

E.3.1

ORIGINAL PAGE IS
OF POOR QUALITY

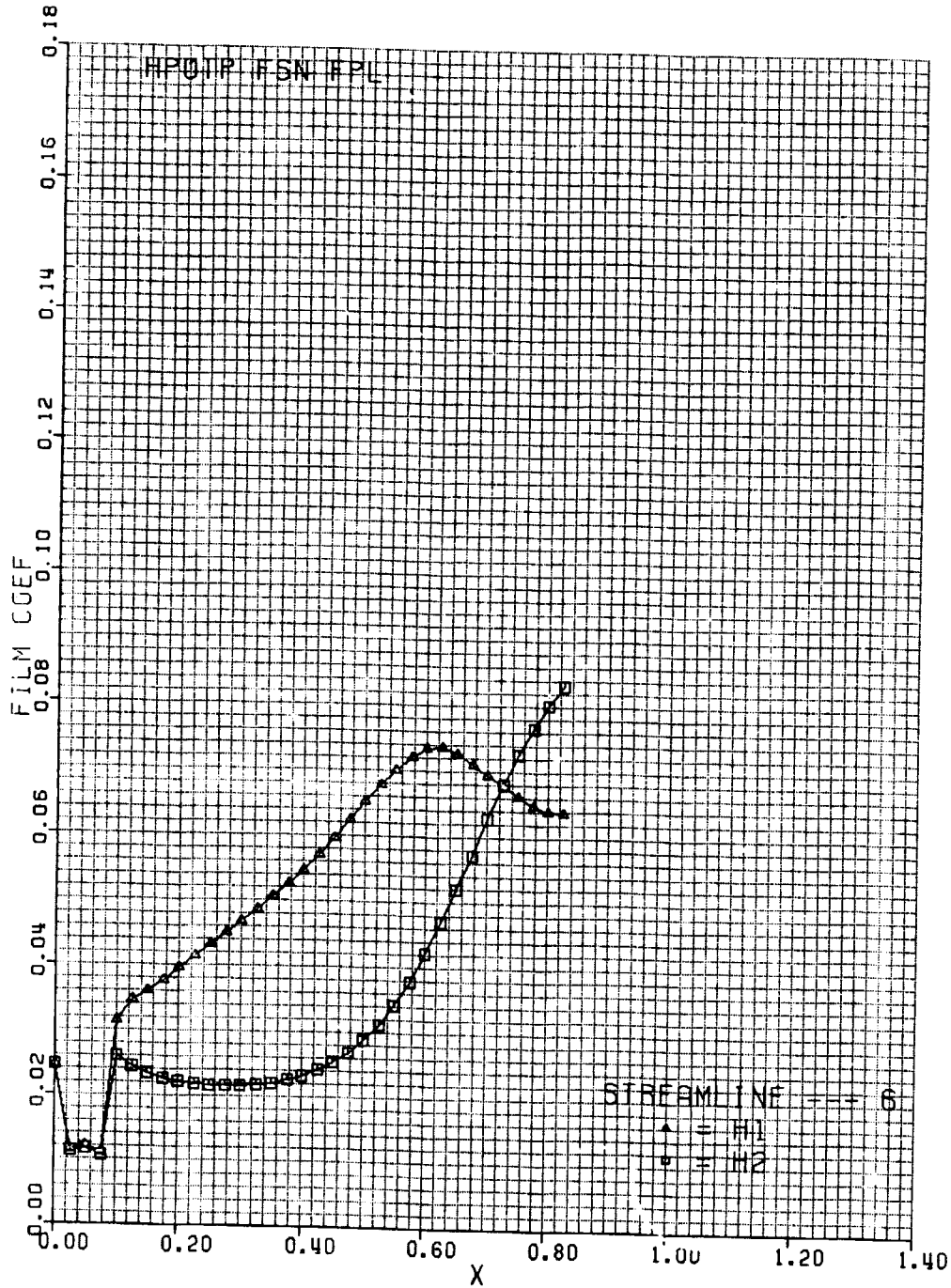

E.3.2

ORIGINAL FORM OF
OF POOR QUALITY

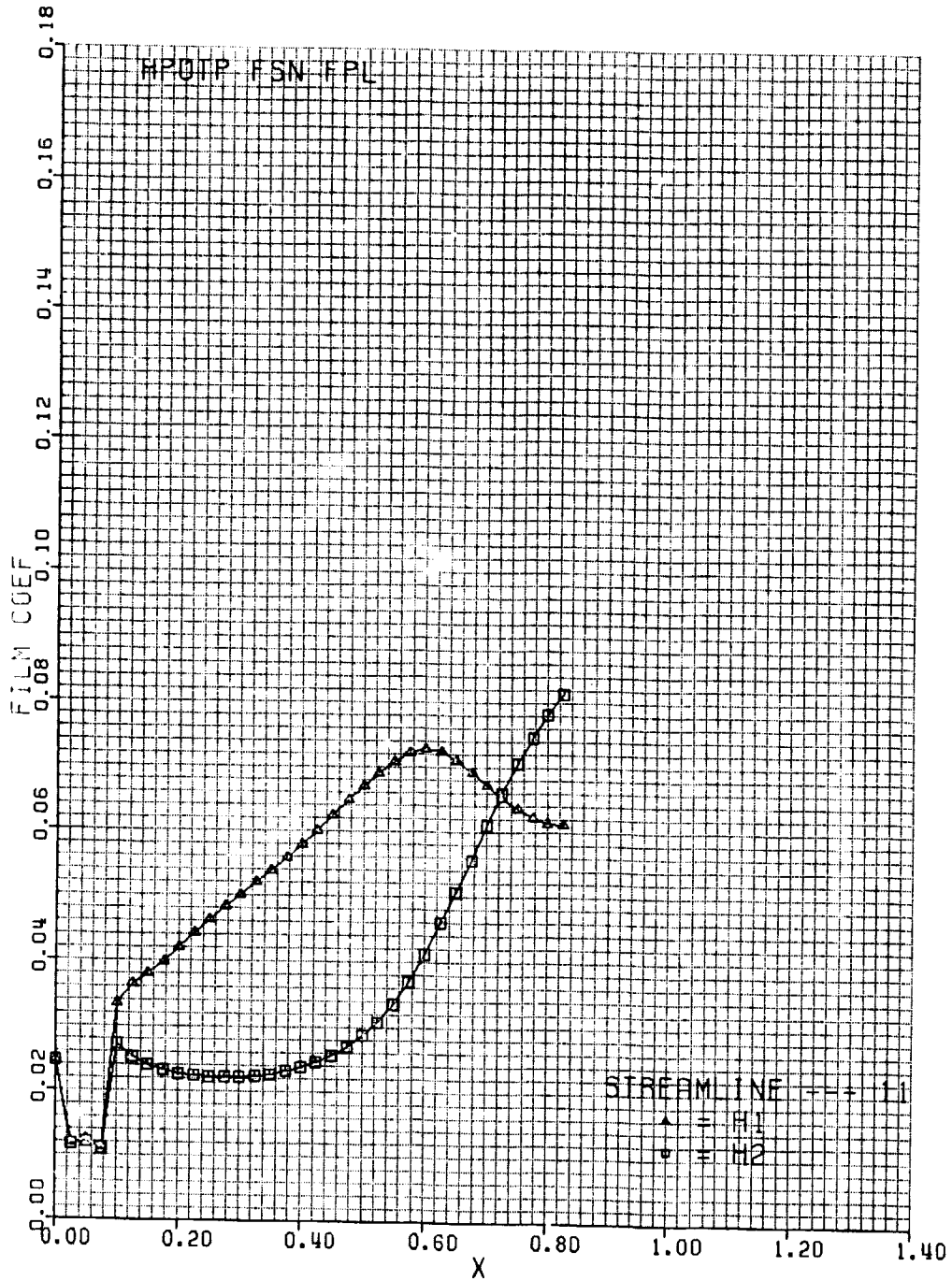

E.3.3

ORIGINAL PAGE IS
OF POOR QUALITY

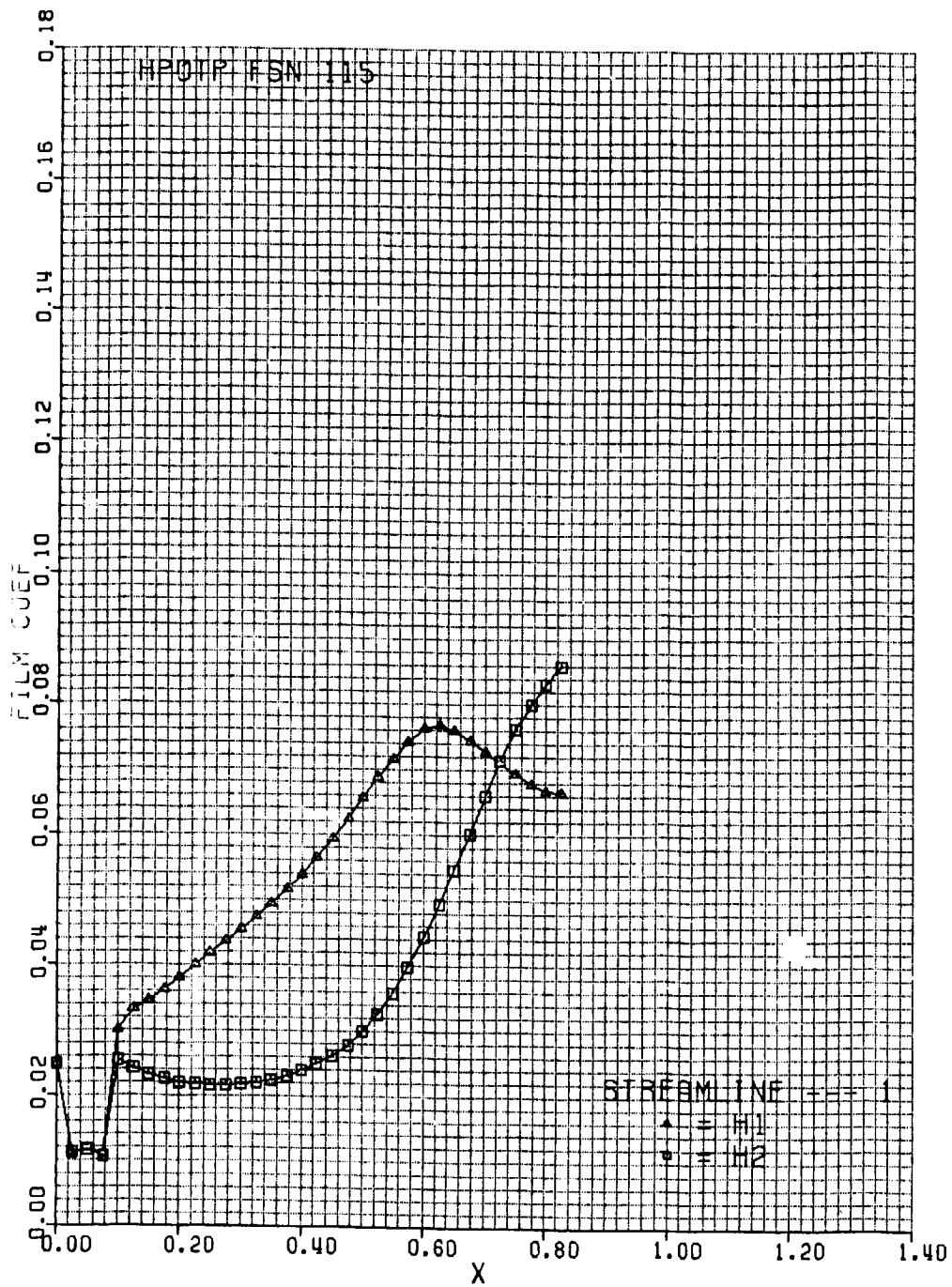

E.4.1

ORIGINAL PHOTO COPY
OF POOR QUALITY

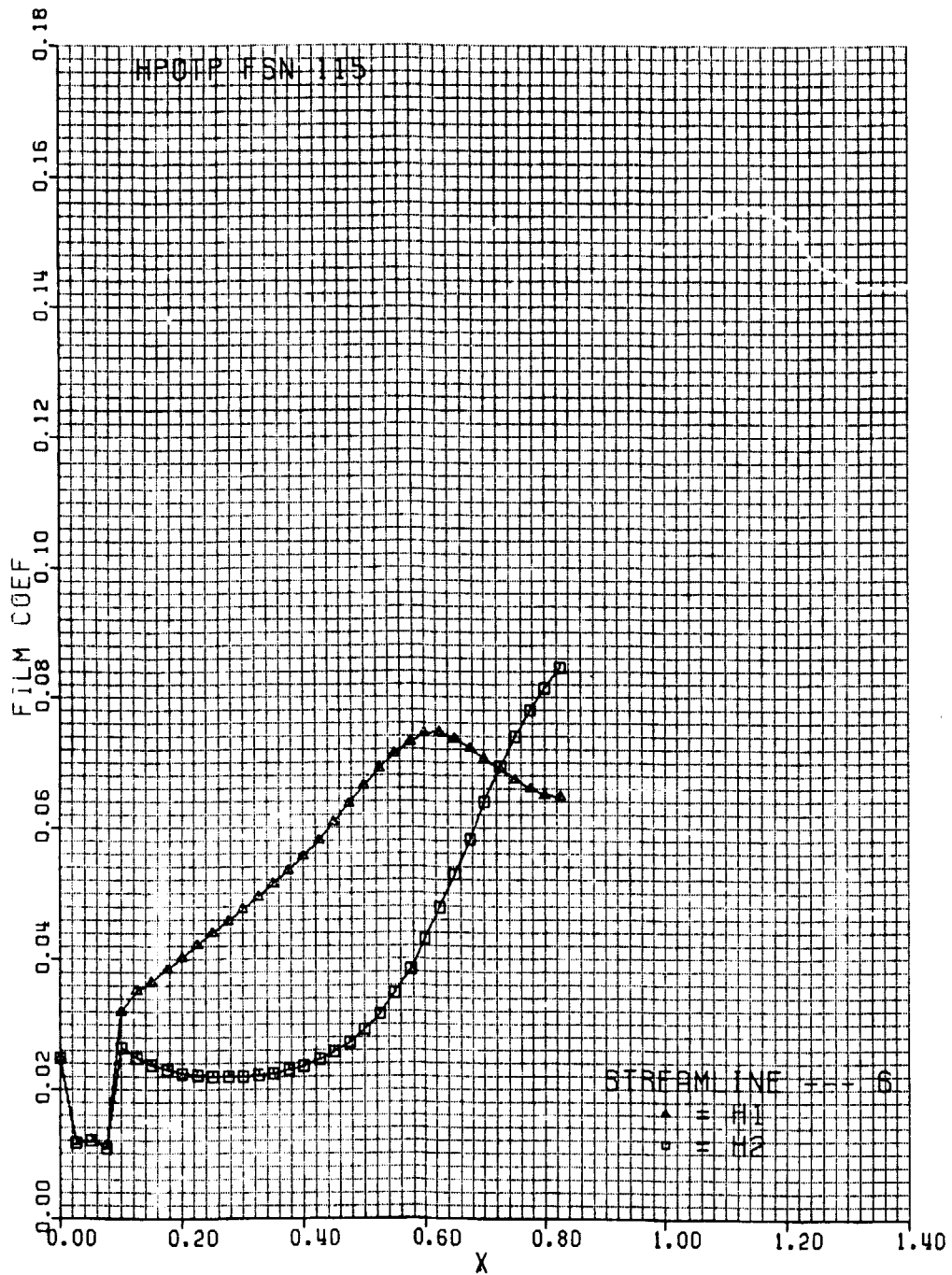

E.4.2

ORIGINAL PAGE IS
OF POOR QUALITY

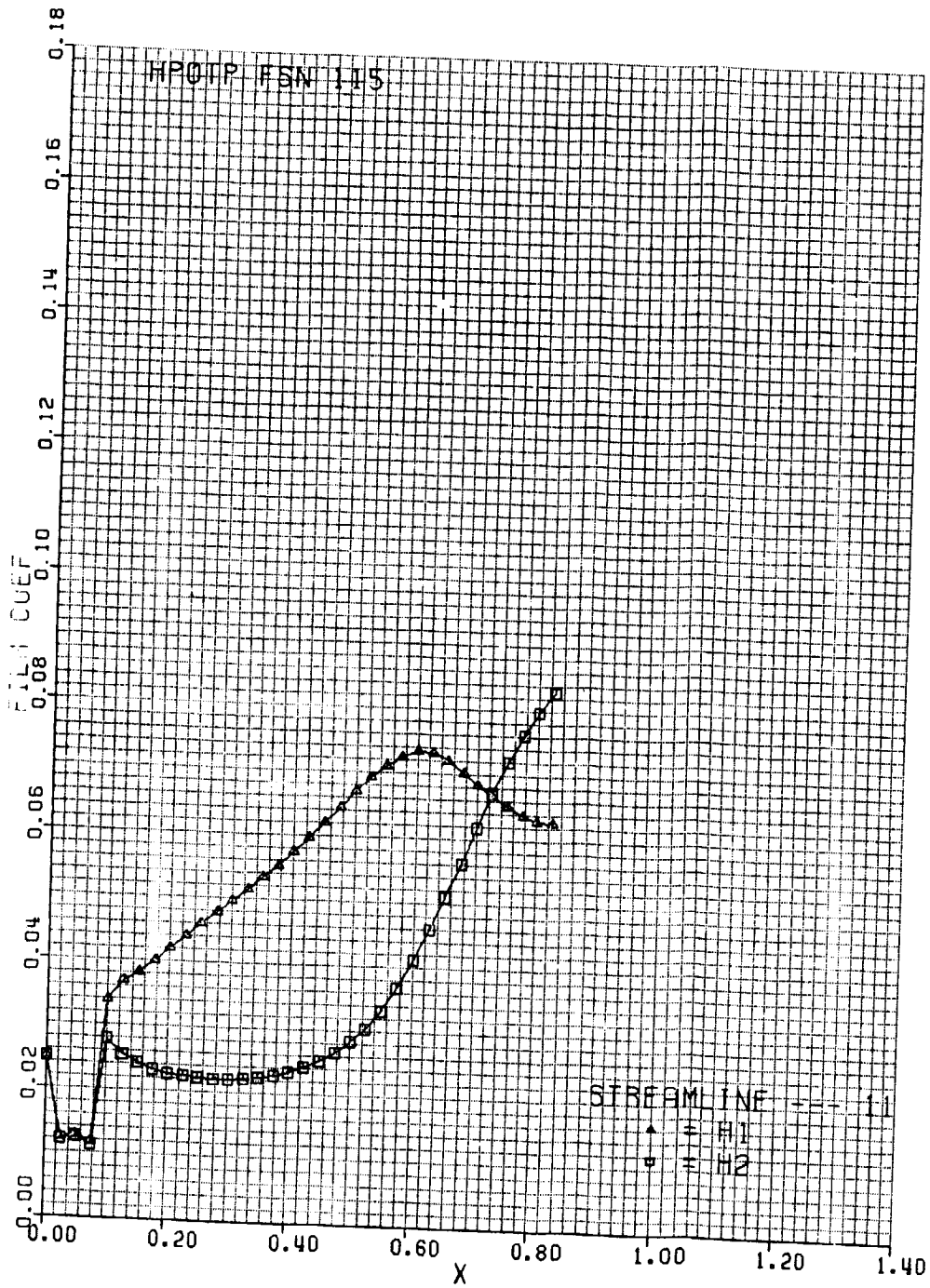

E.4.3

LOCKHEED-HUNTSVILLE RESEARCH & ENGINEERING CENTER

Appendix F

HPOTP FIRST STAGE BLADE PRESSURE, ADIABATIC WALL TEMPERATURE
AND HEAT TRANSFER COEFFICIENT DISTRIBUTIONS

- F.1 FPL Pressure Distributions
- F.2 115 Percent Power Level Pressure Distributions
- F.3 FPL Heat Transfer Coefficients
- F.4 115 Percent Power Level Heat Transfer Coefficients

Surface 1 - Pressure Surface \triangle Surface 2 - Suction Surface \square Approximate Adiabatic Wall
Temperatures (F)

	FPL	115 Percent
Streamline 1 - R = 4.7915	975	1150
Streamline 6 - R = 5.04	975	1150
Streamline 11 - R = 5.2885	975	1150

ORIGINAL FROM
OF POOR QUALITY

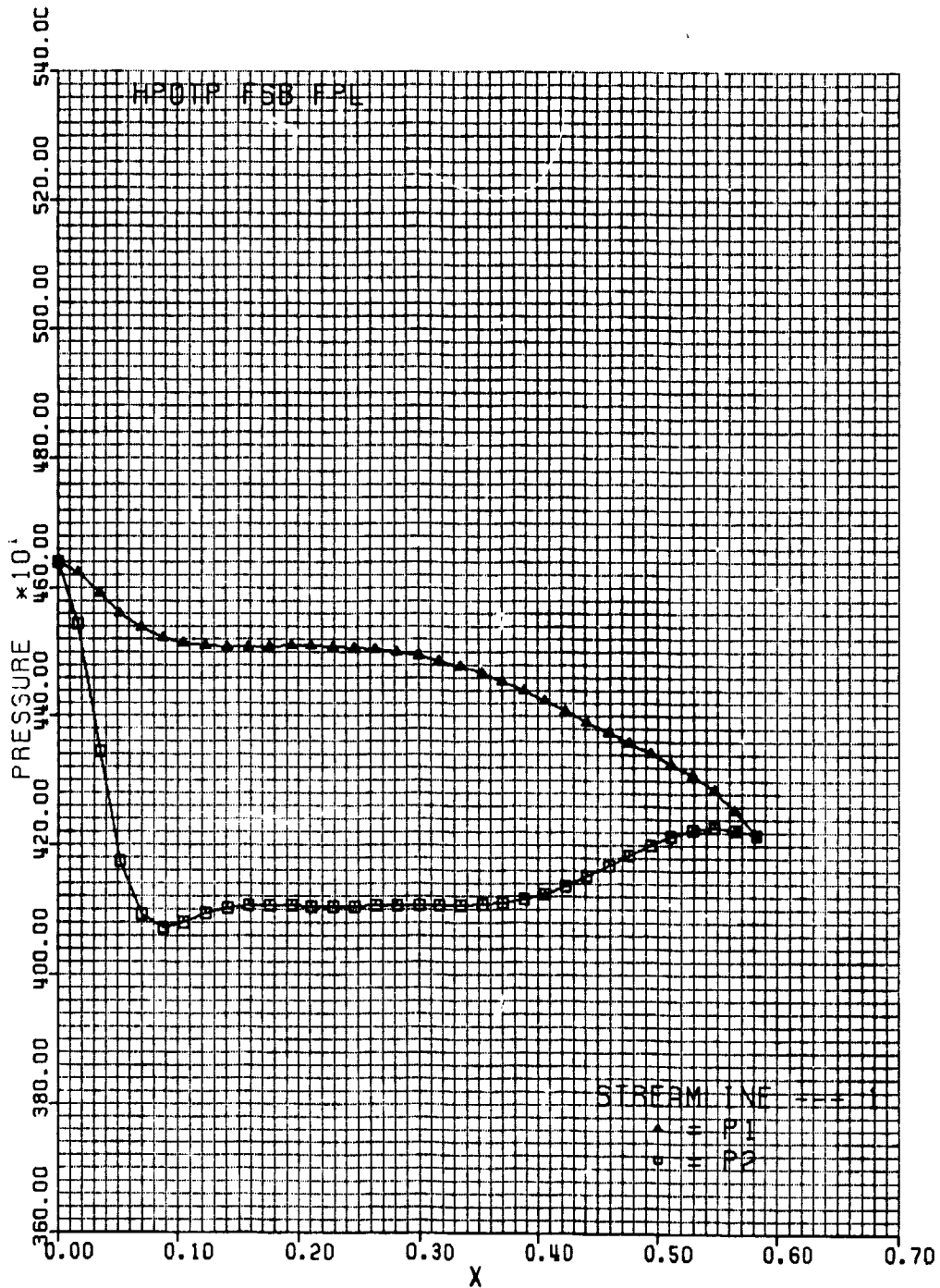

F.1.1

ORIGINAL PAGE IS
OF POOR QUALITY

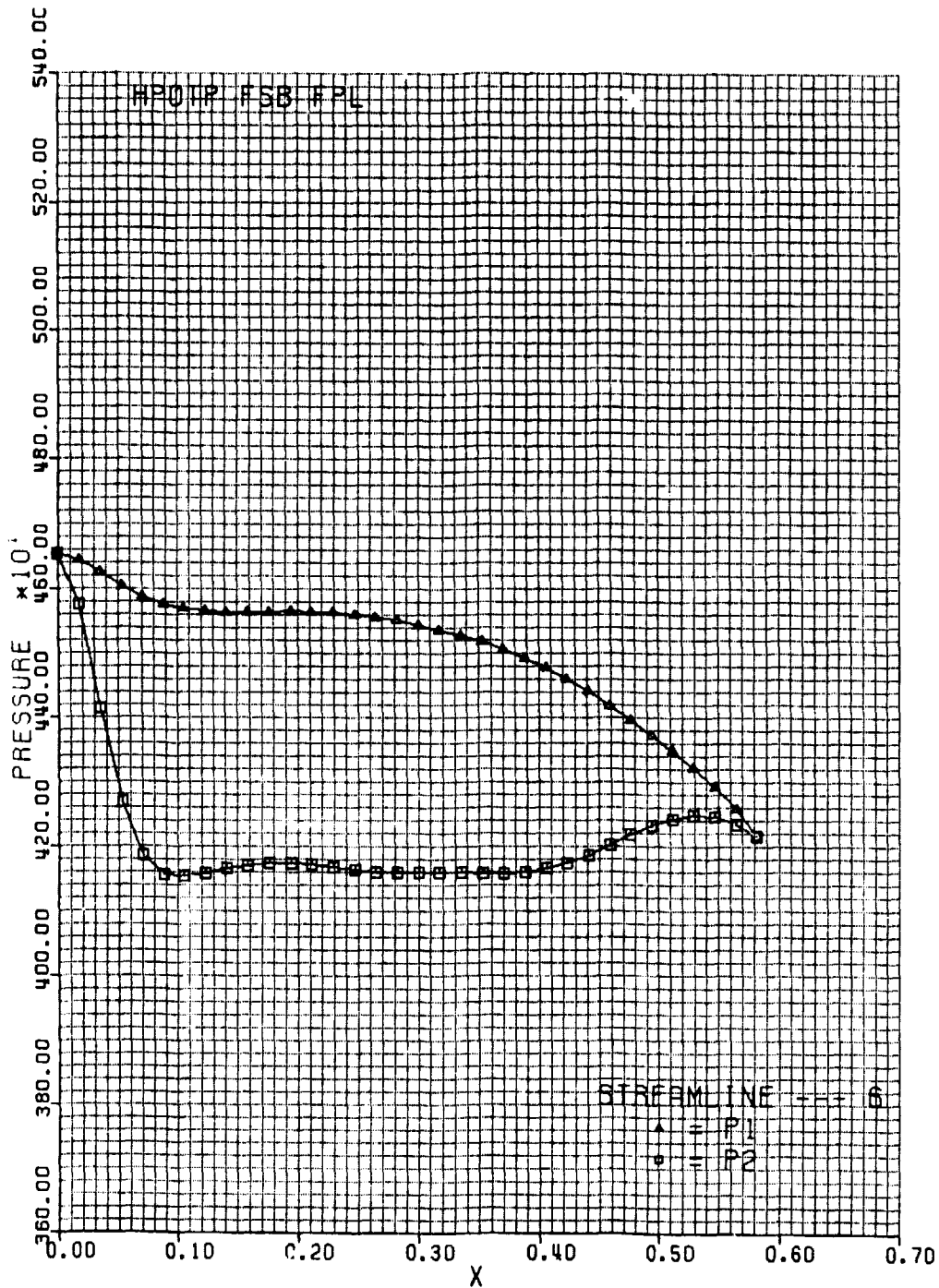

F.1.2

ORIGINAL PAGE IS
OF POOR QUALITY

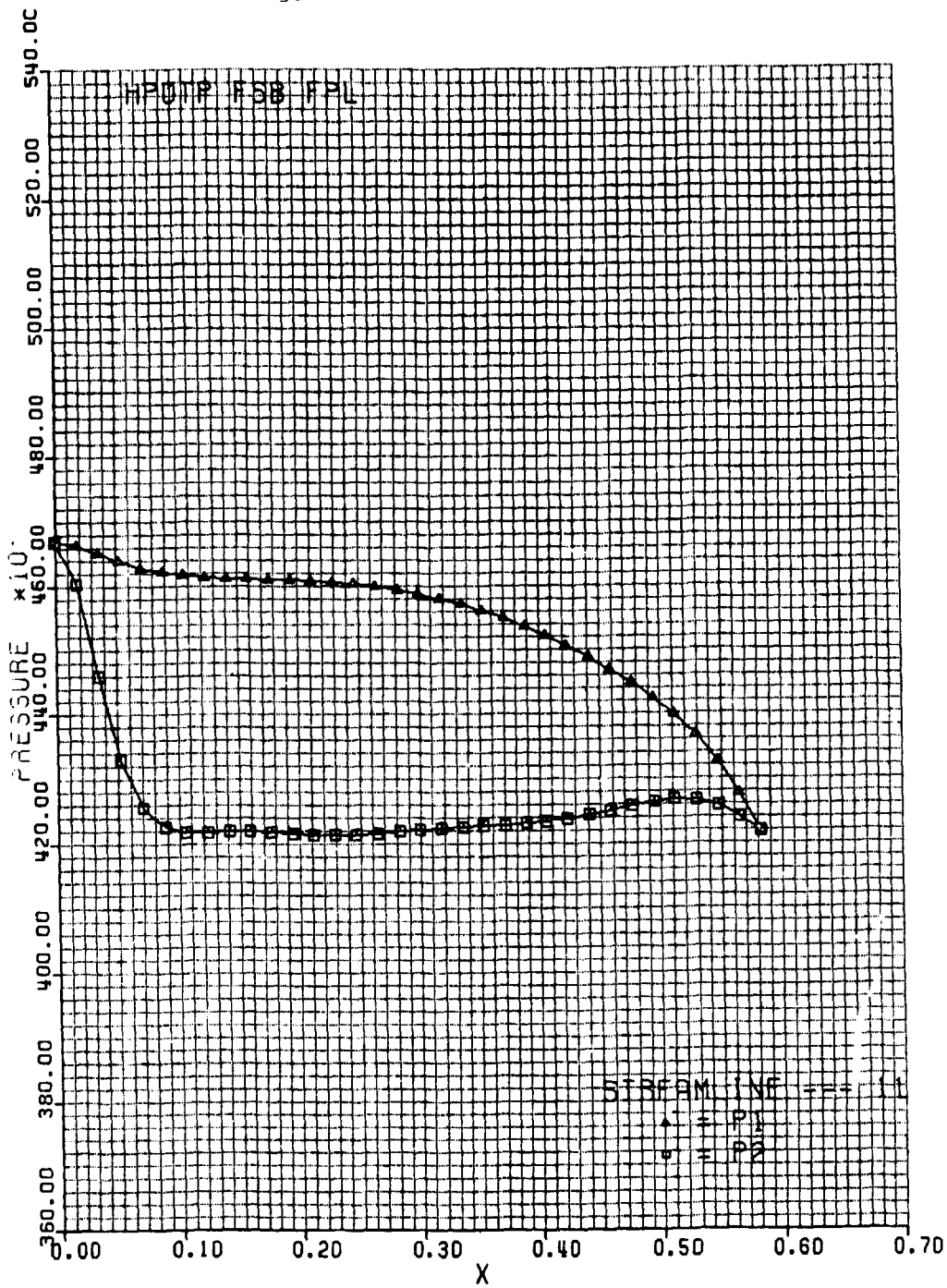

F.1.3

ORIGINAL MANUSCRIPT
OF POOR QUALITY

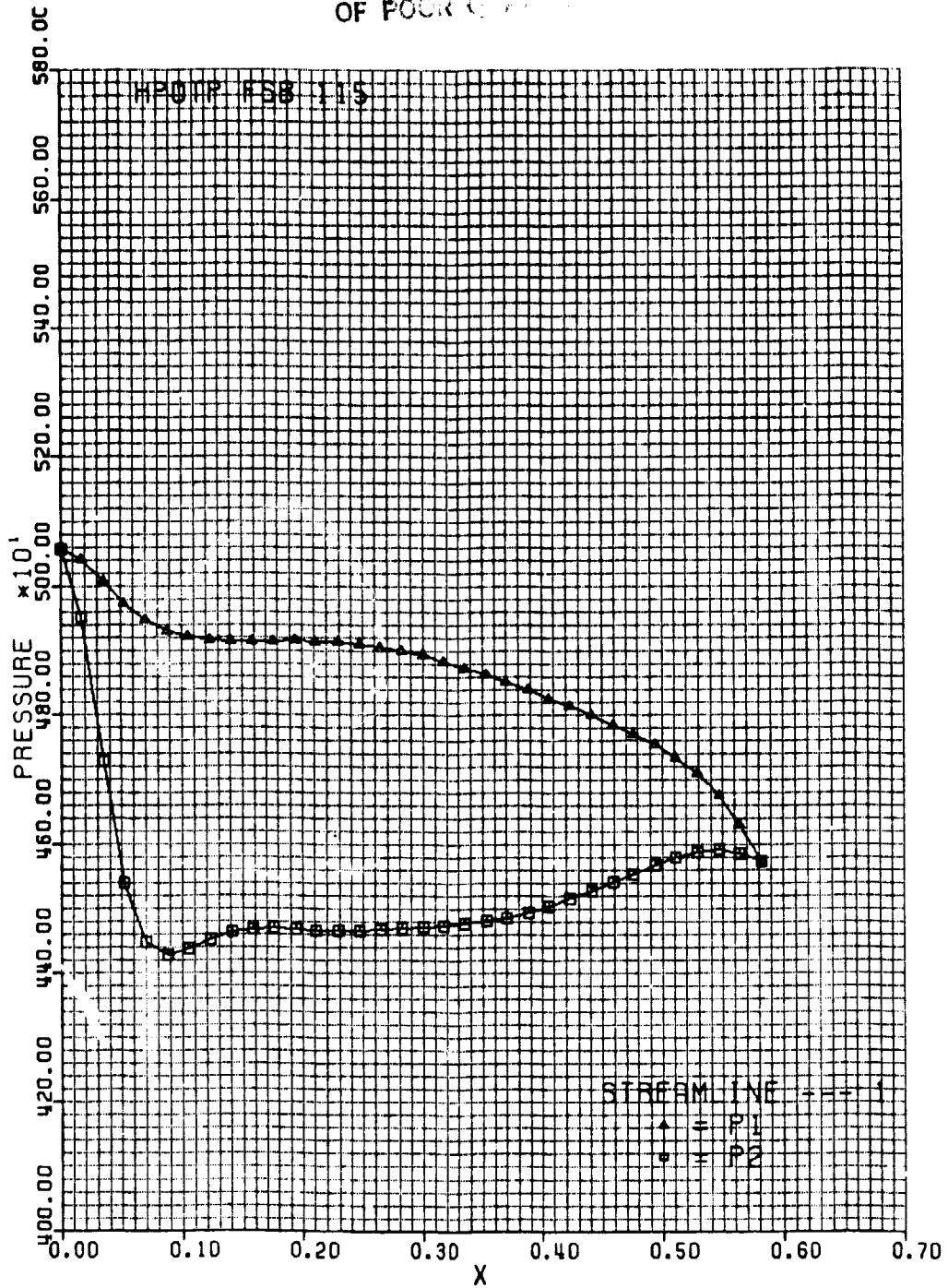

F.2.1

ORIGINAL PAGE IS
OF POOR QUALITY

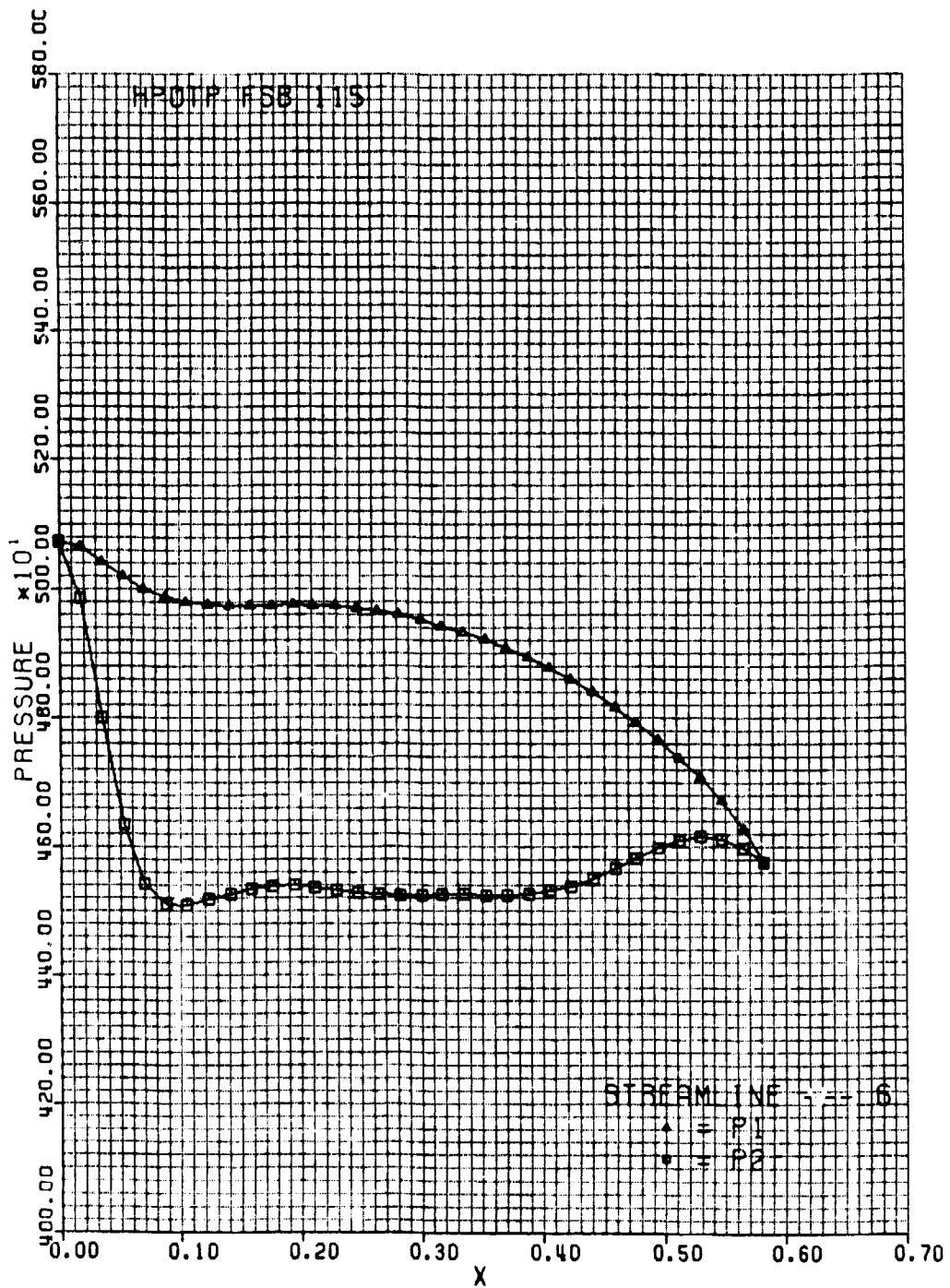

F.2.2

ORIGINAL PRICE IS
OF POOR QUALITY

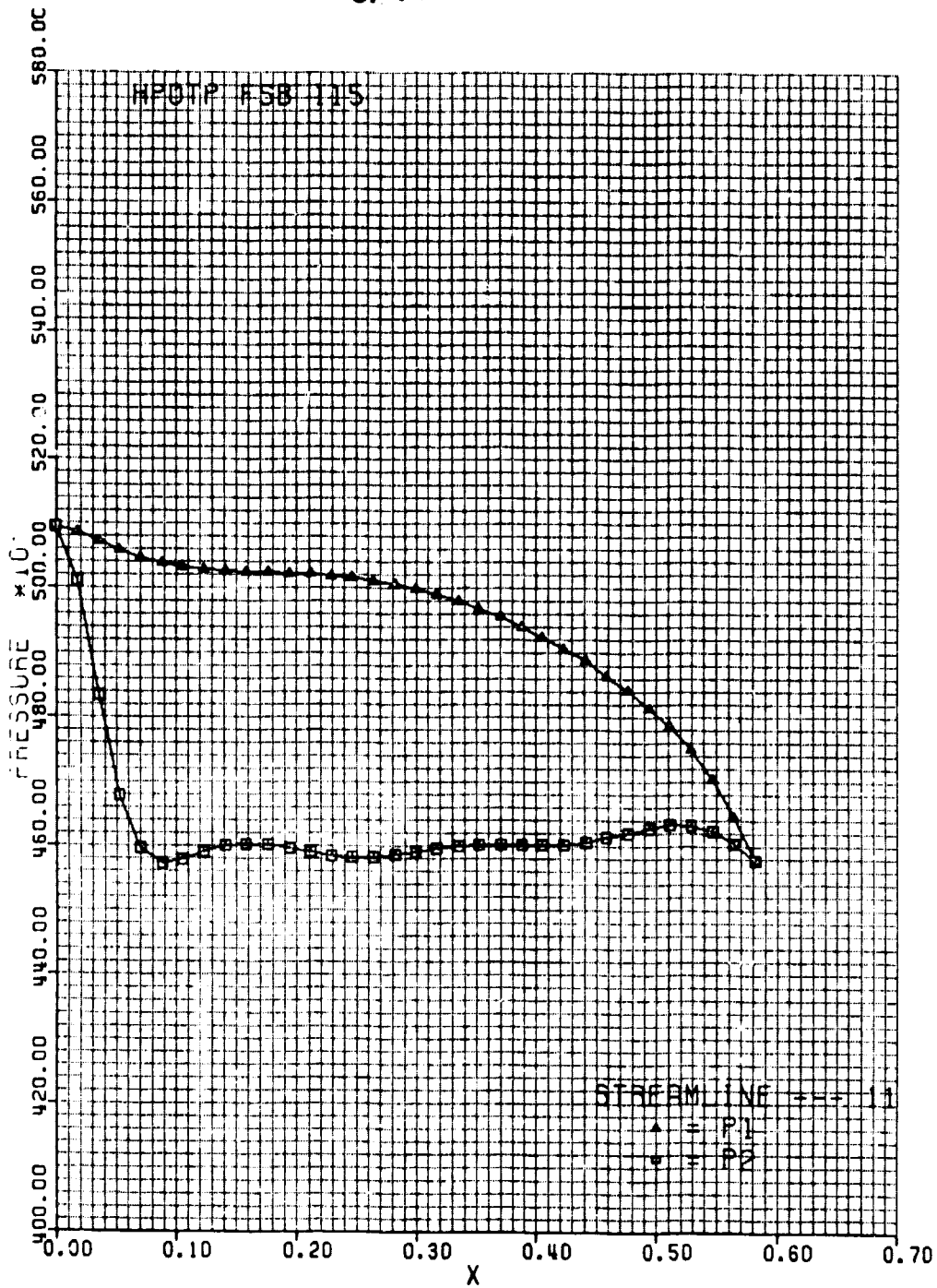

F.2.3

ORIGINAL PAGE IS
OF POOR QUALITY

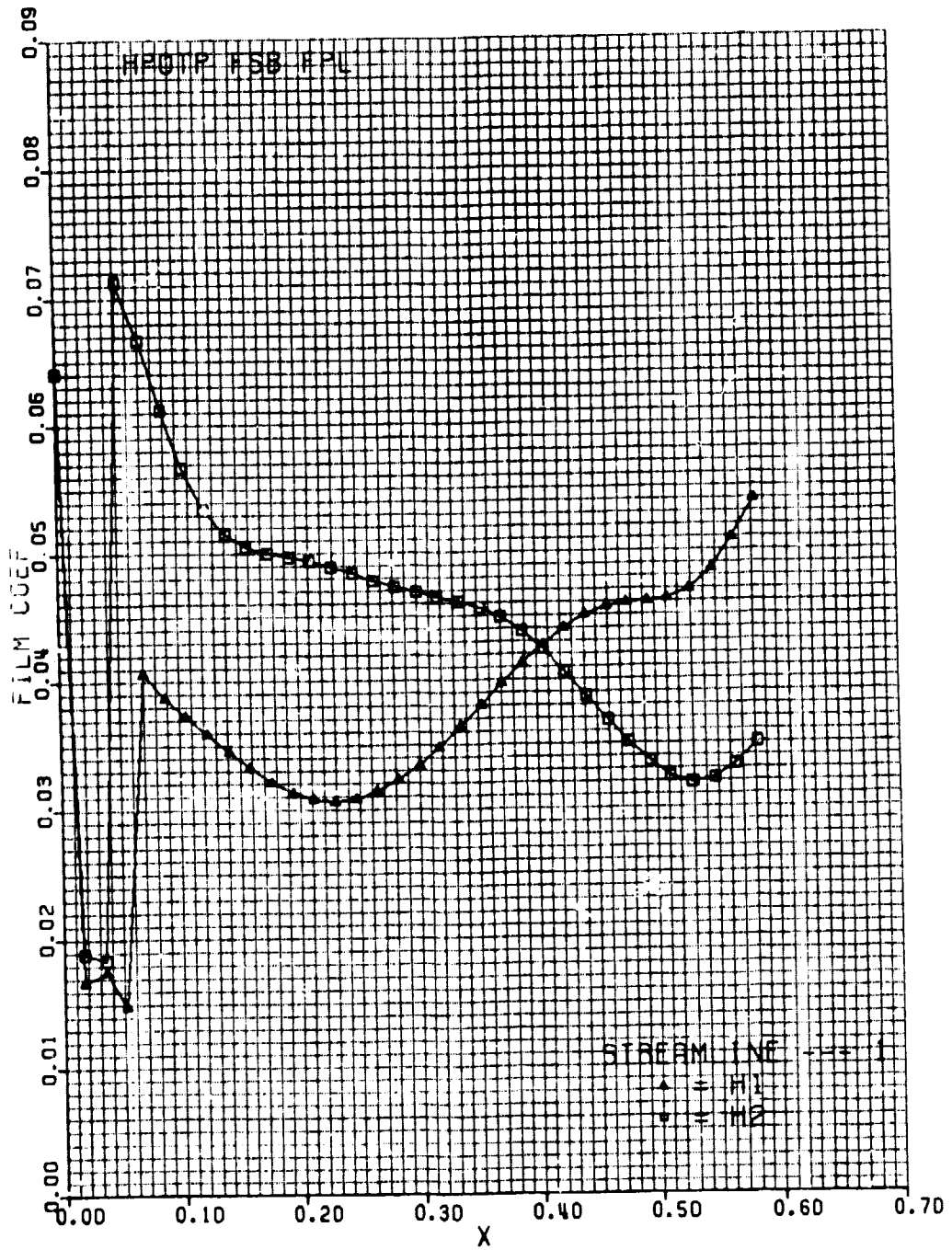

F.3.1

ORIGINAL PROFILES
OF POOR QUALITY

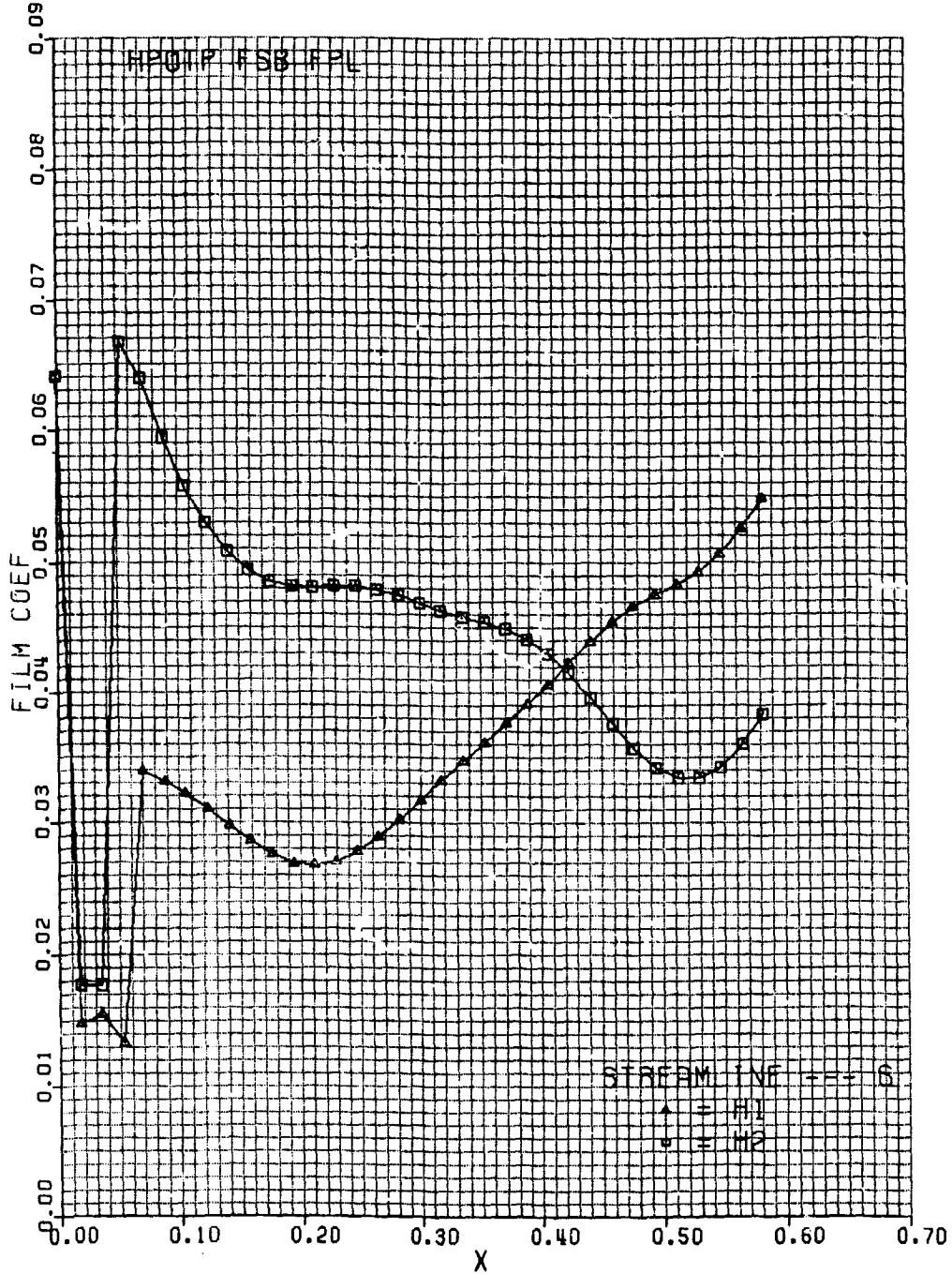

F.3.2

ORIGINAL PAGE IS
OF POOR QUALITY

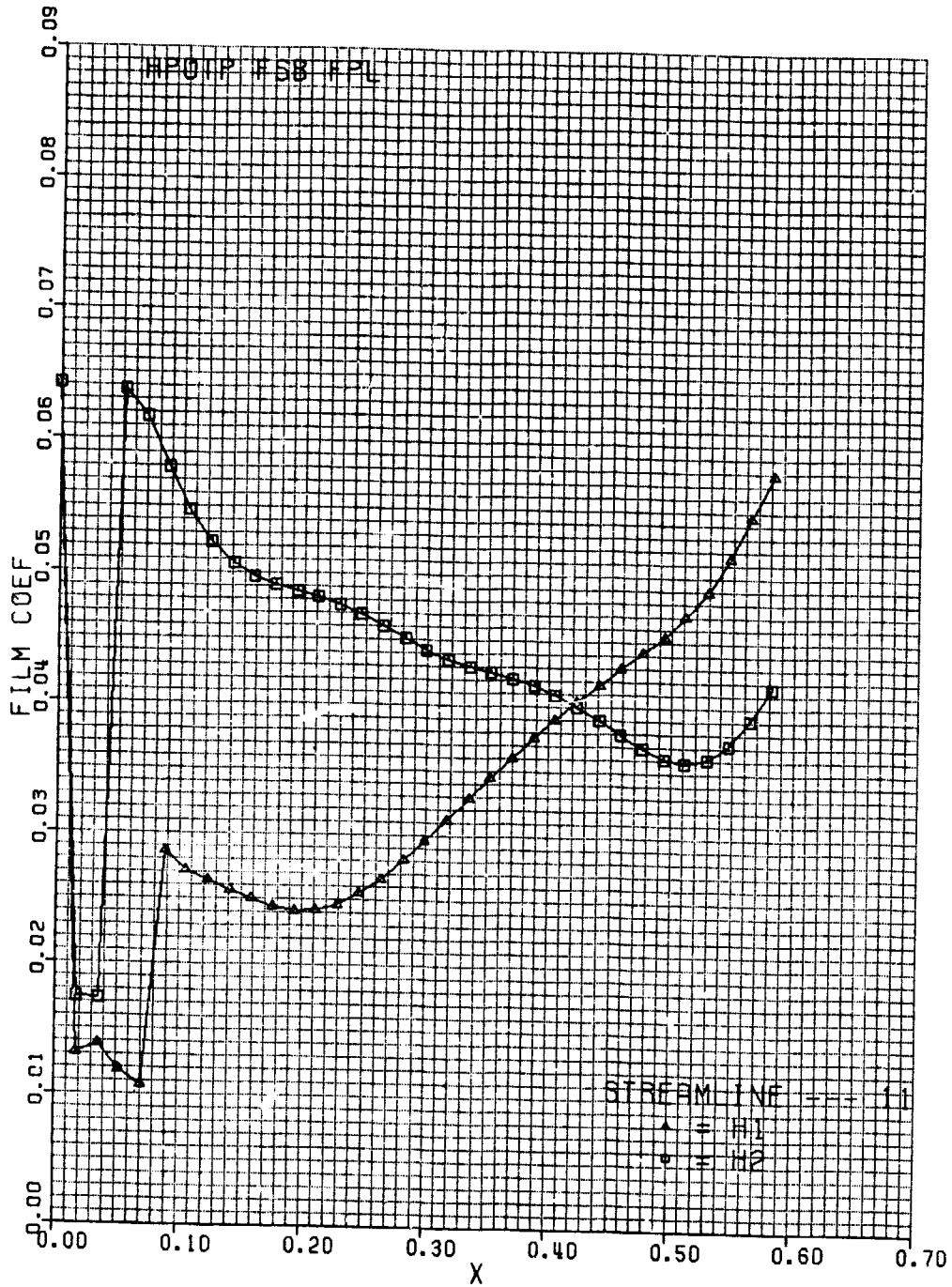

F.3.3

ORIGINAL PAGE IS
OF POOR QUALITY

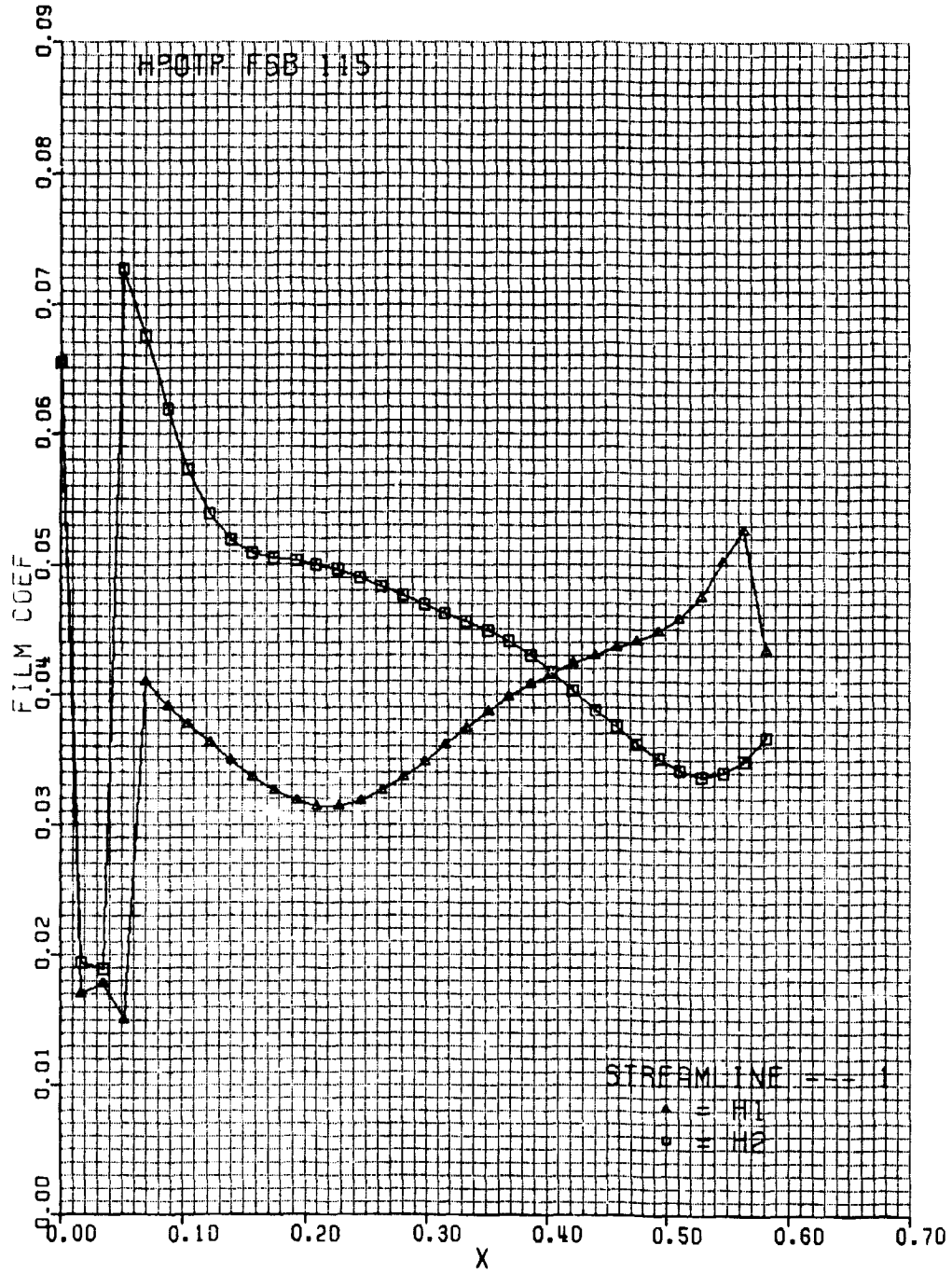

F.4.1

ORIGINAL PAGE IS
OF POOR QUALITY

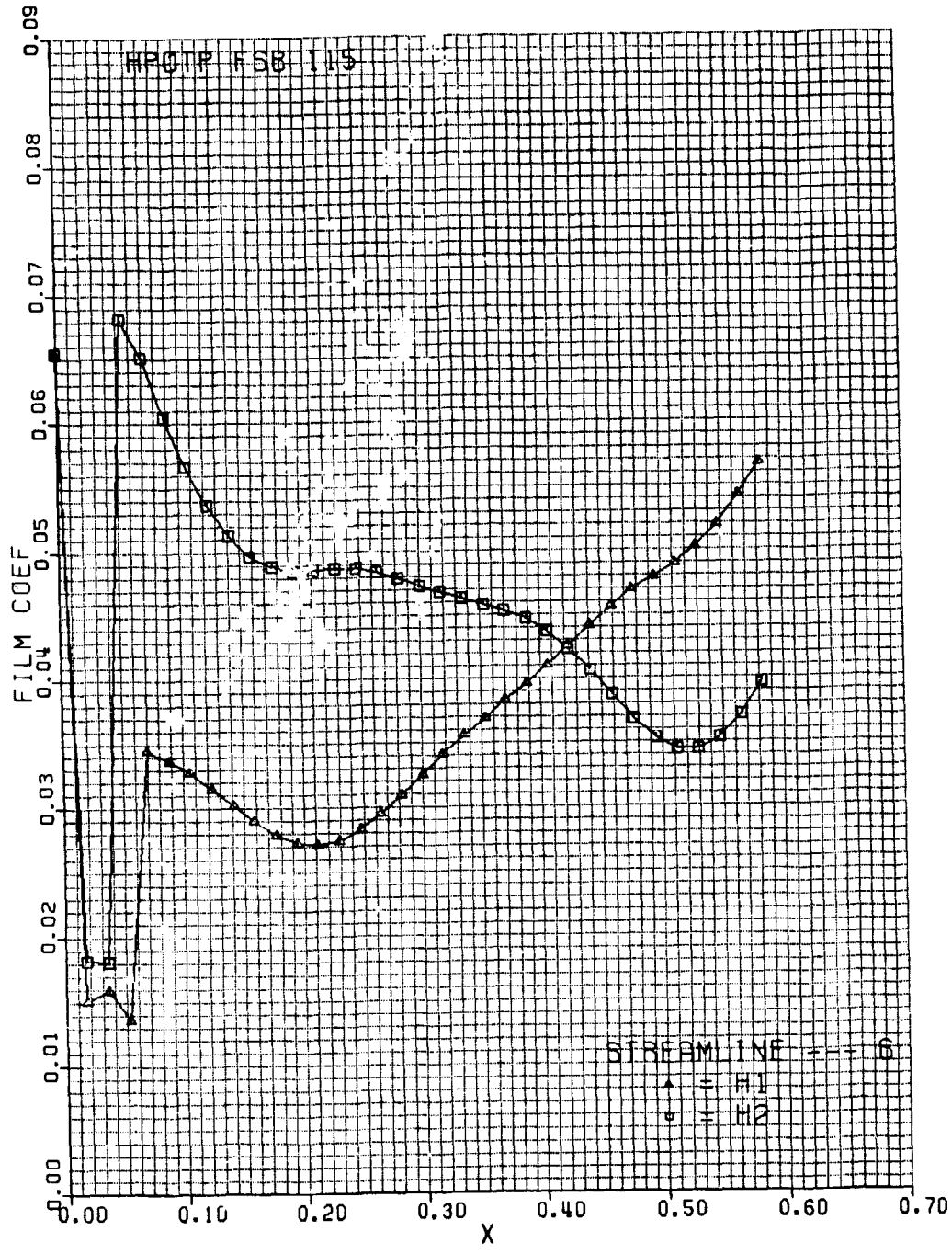

F.4.2

ORIGINAL PAGE IS
OF POOR QUALITY

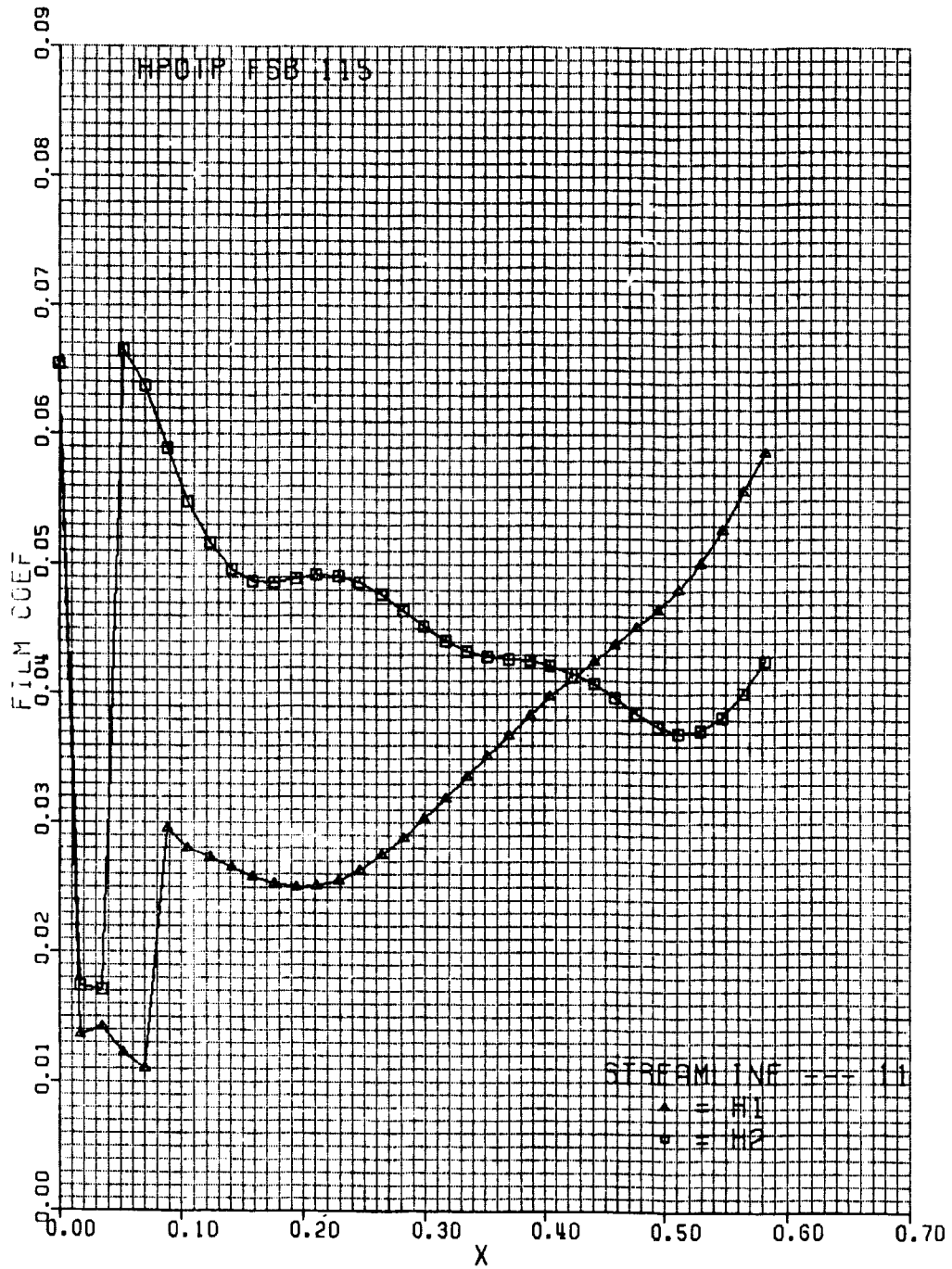

F.4.3

Appendix G

HPOTP SECOND STAGE NOZZLE PRESSURE, ADIABATIC WALL TEMPERATURE
AND HEAT TRANSFER COEFFICIENT DISTRIBUTIONS

- G.1 FPL Pressure Distributions
- G.2 115 Percent Power Level Pressure Distributions
- G.3 FPL Heat Transfer Coefficients
- G.4 115 Percent Power Level Heat Transfer Coefficients

Surface 1 - Suction Surface \triangle
Surface 2 - Pressure Surface \square

Approximate Adiabatic Wall
Temperatures (F)

	FPL	115 Percent
Streamline 1 - R = 4.705	945	1120
Streamline 6 - R = 5.04	945	1120
Streamline 11 - R = 5.375	945	1120

ORIGINAL PAGE IS
OF POOR QUALITY

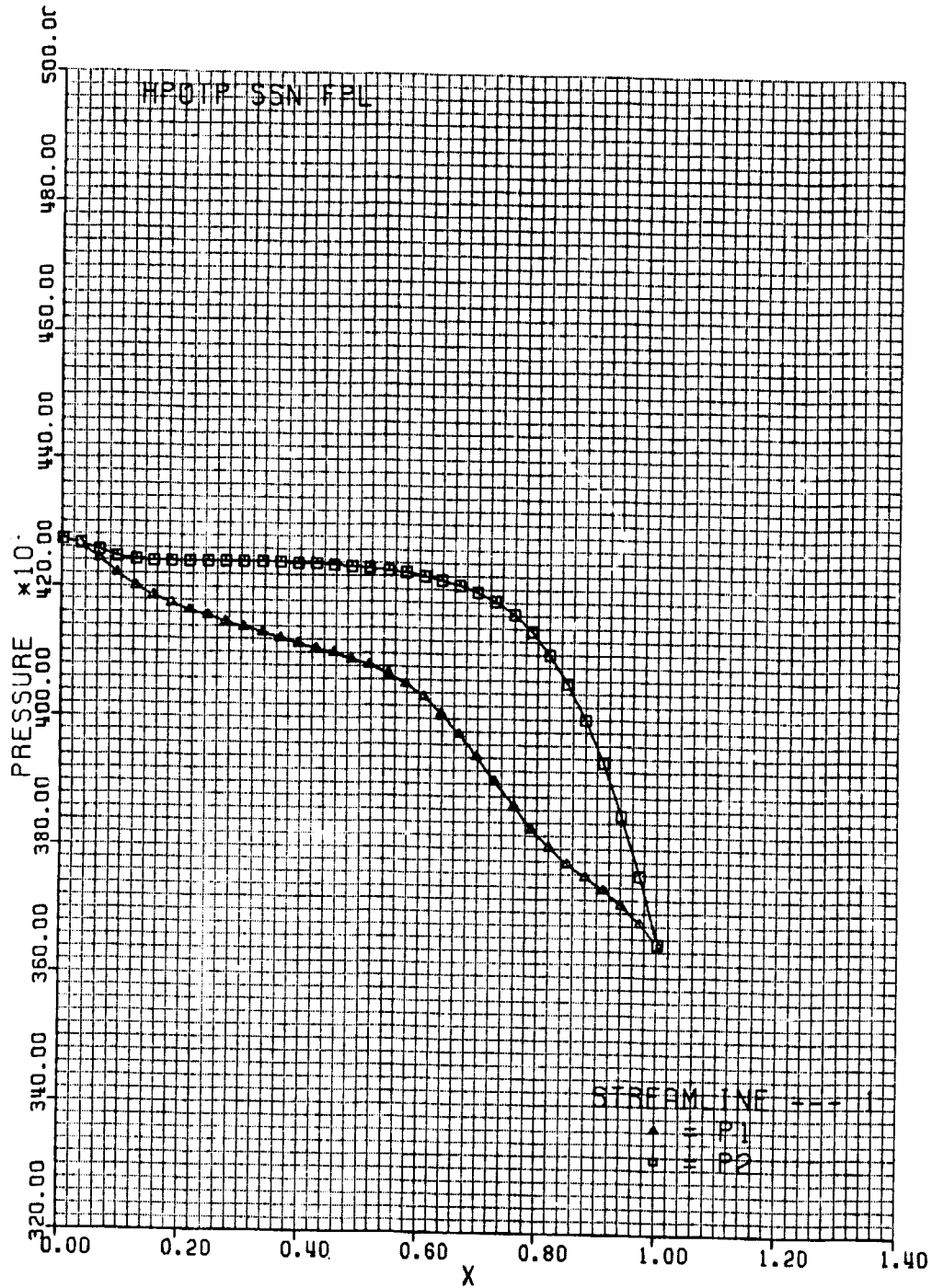

G.1.1

ORIGINAL PAGE IS
OF POOR QUALITY

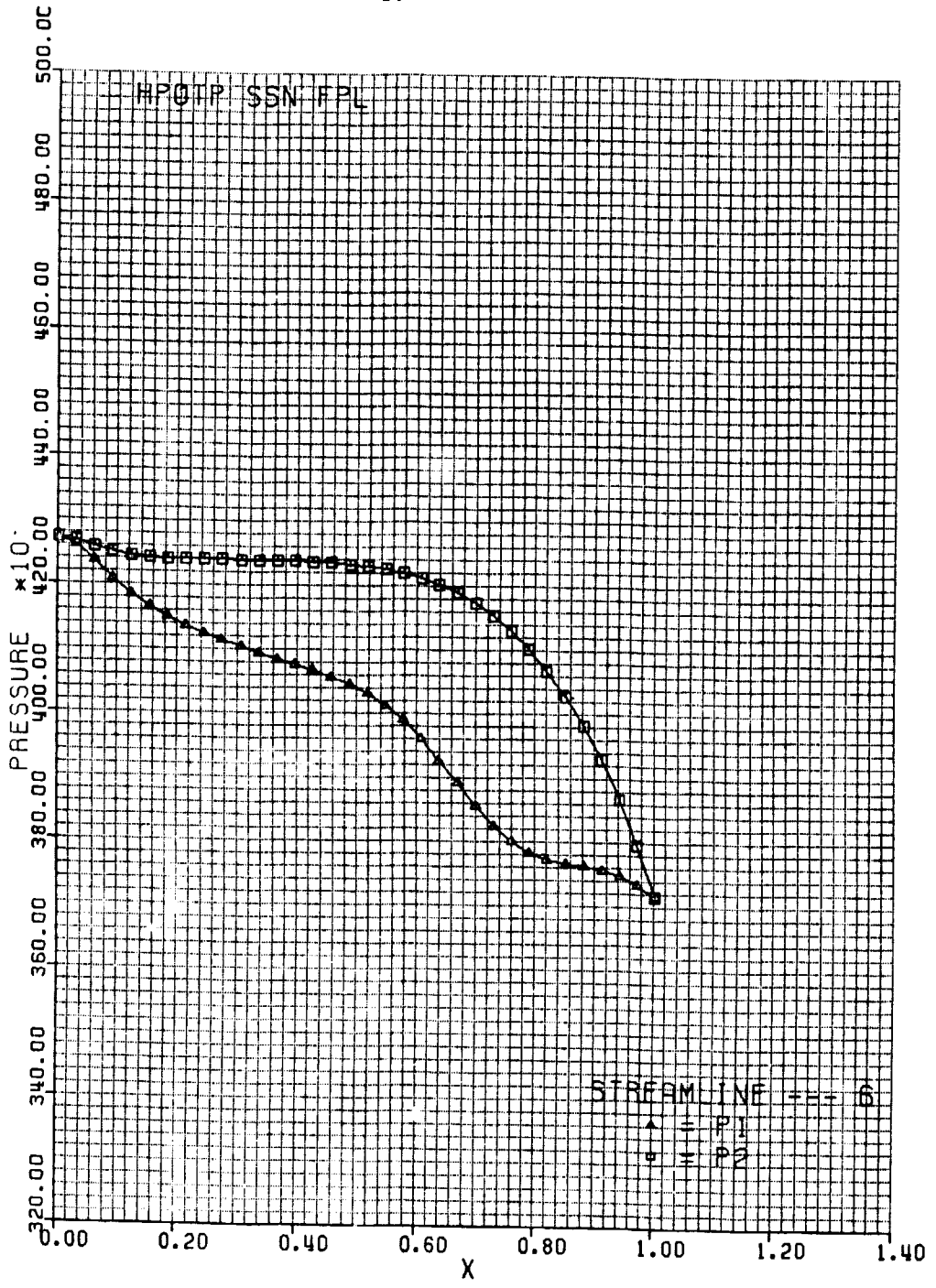

G.1.2

ORIGINAL PAGE IS
OF POOR QUALITY

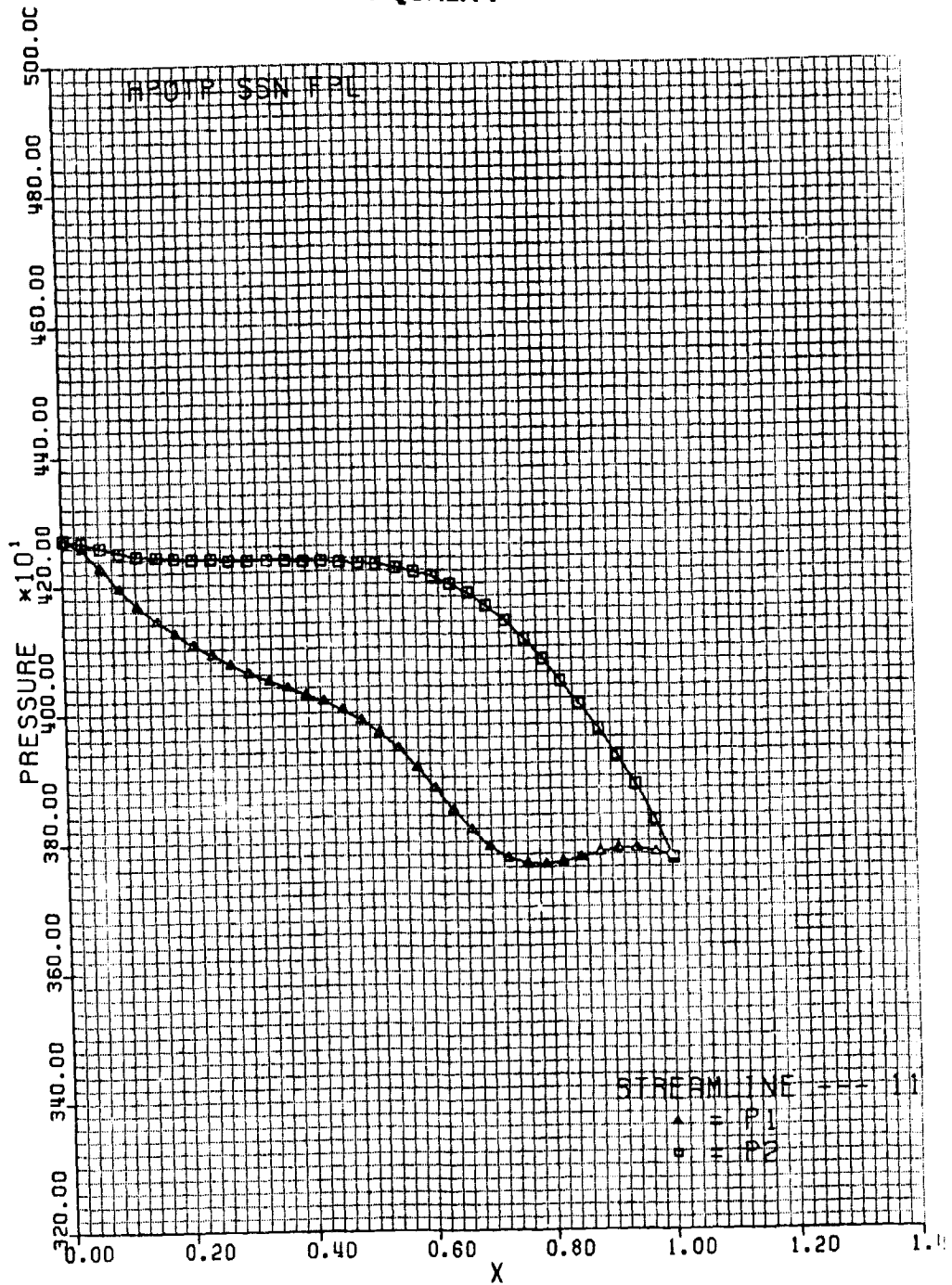

G.1.3

ORIGINAL PAGE IS
OF POOR QUALITY

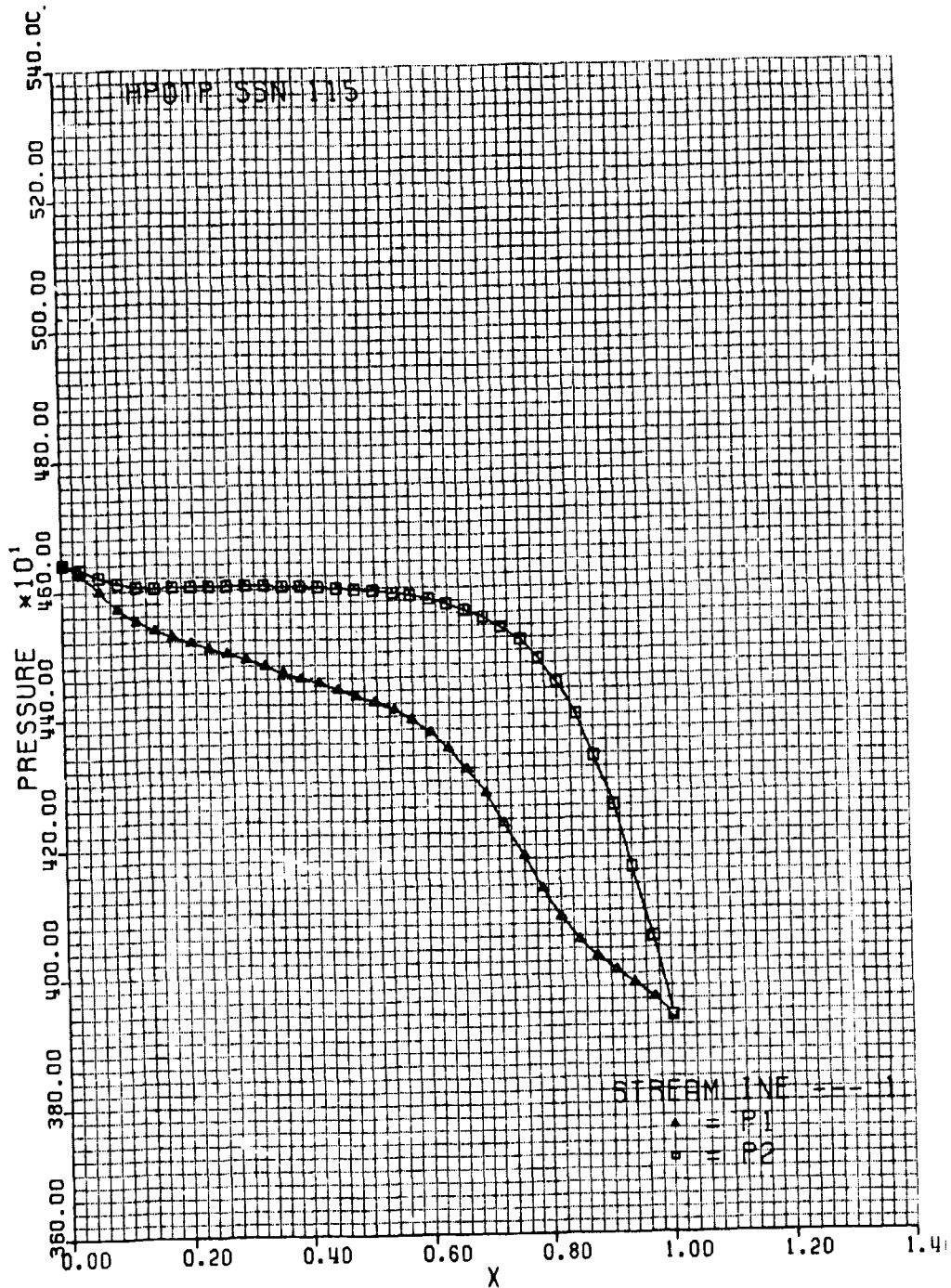

G.2.1

ORIGINAL PAGE IS
OF POOR QUALITY

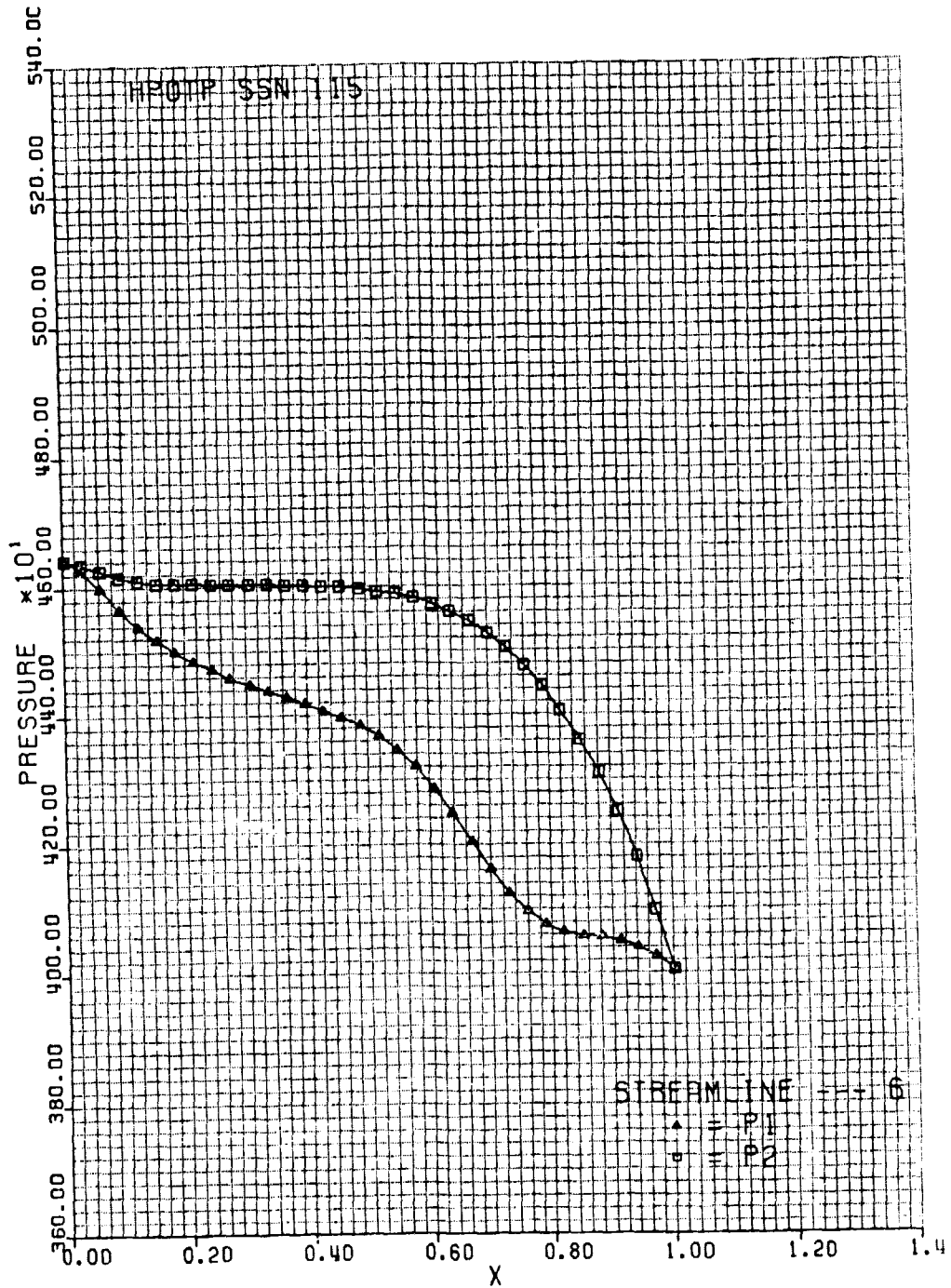

G.2.2

ORIGINAL PAGE IS
OF POOR QUALITY

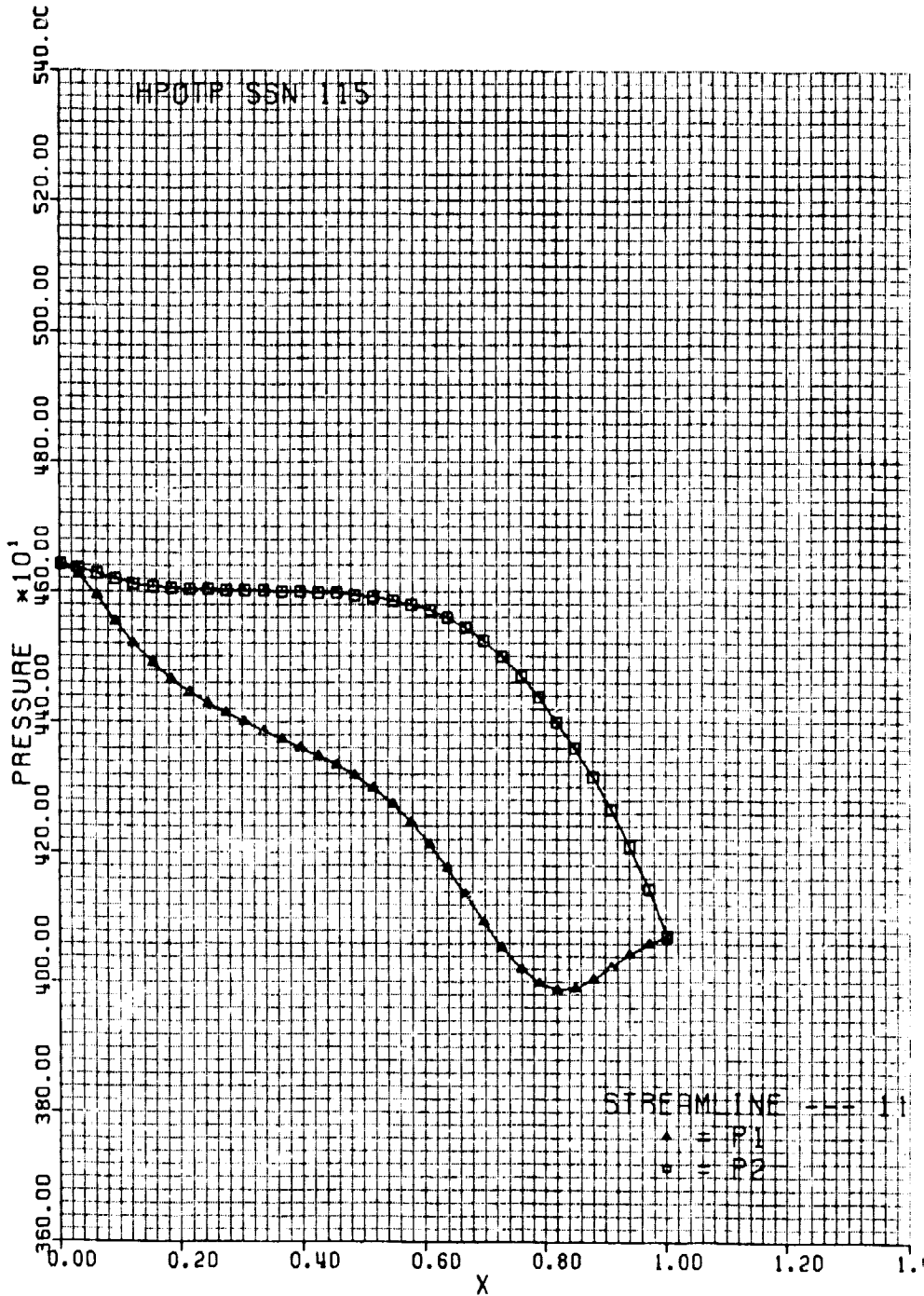

G.2.3

ORIGINAL PAGE IS
OF POOR QUALITY

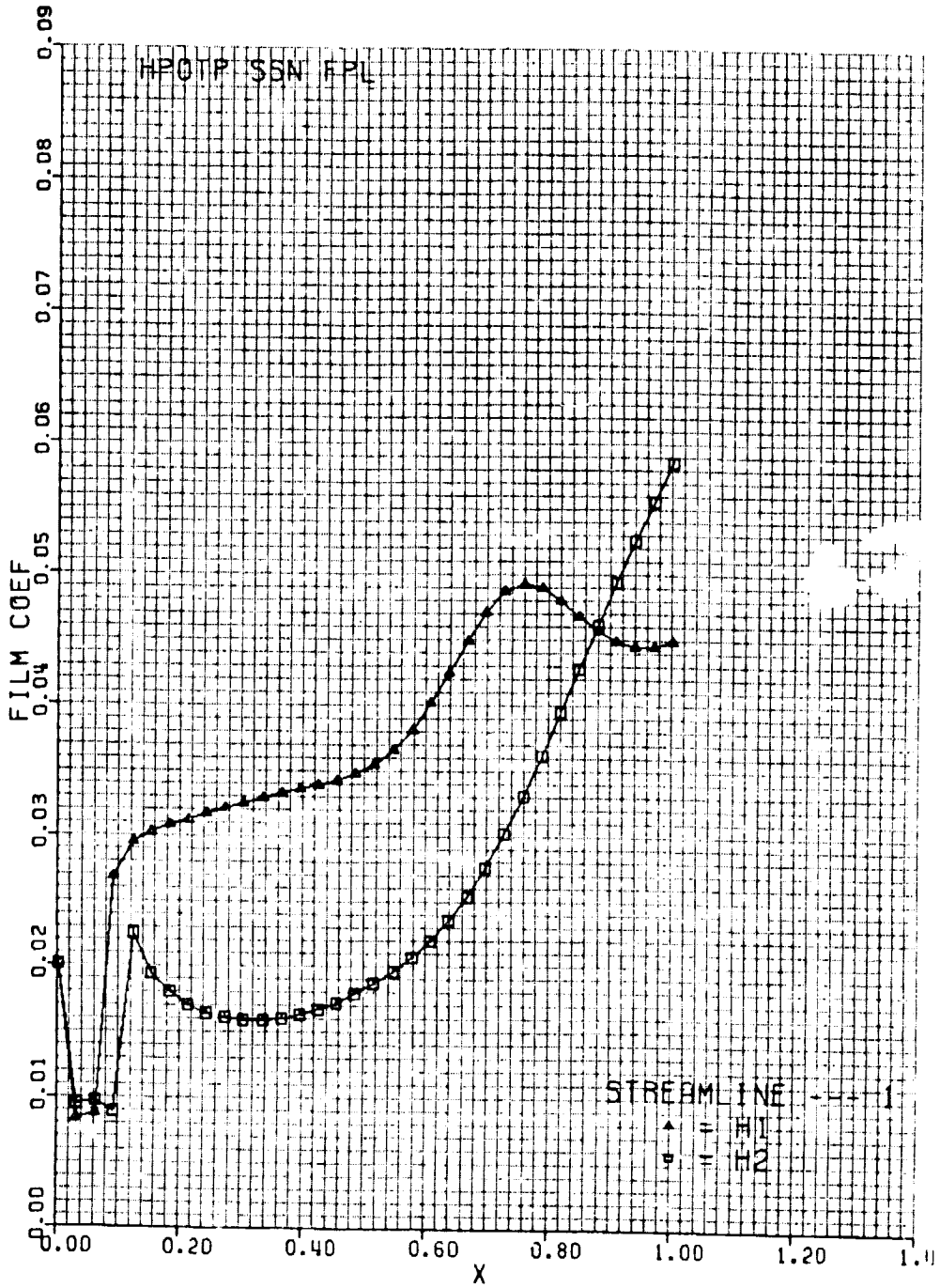

G.3.1

ORIGINAL PAGE IS
OF POOR QUALITY

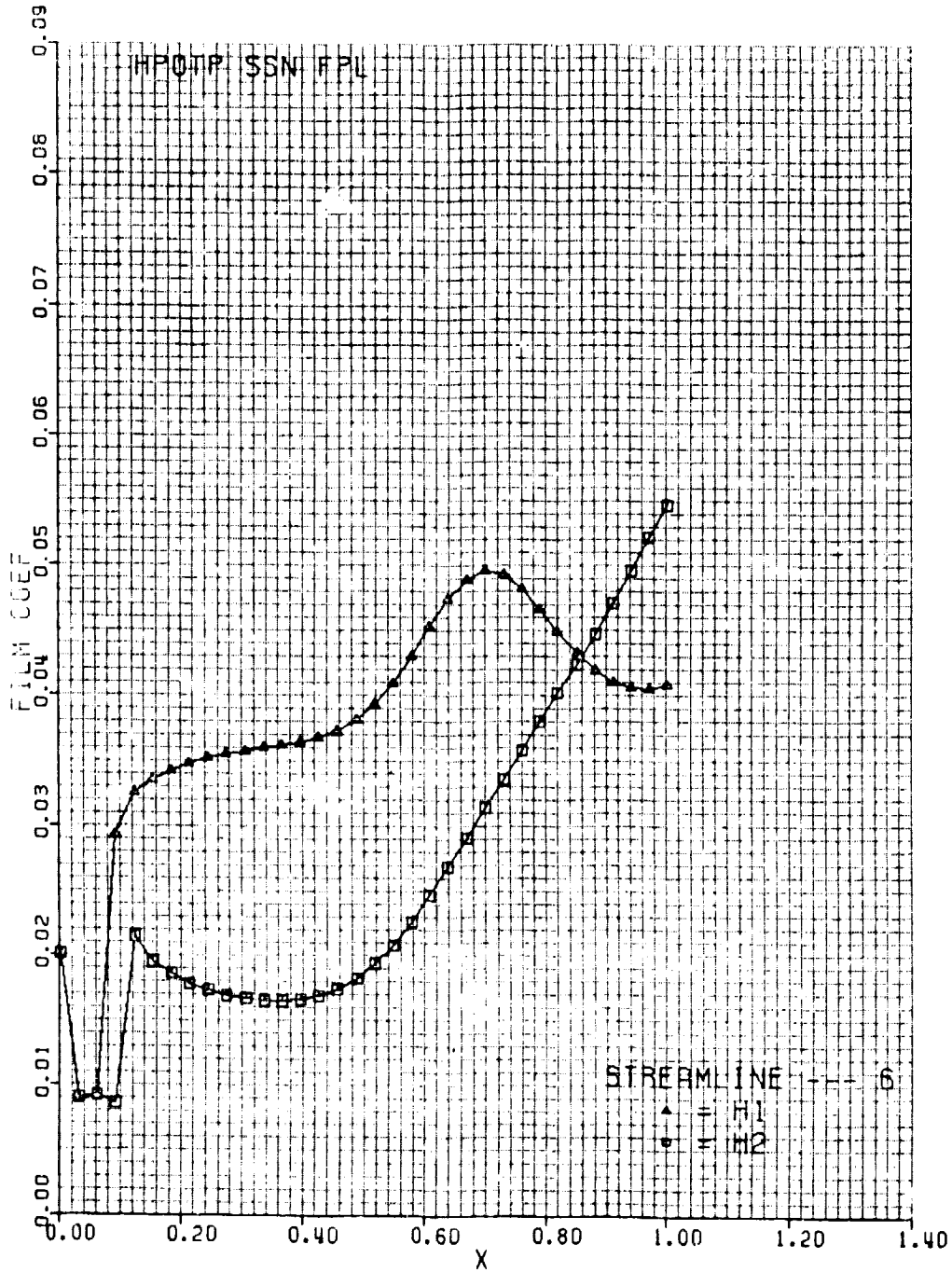

G.3.2

ORIGINAL PAGE IS
OF POOR QUALITY

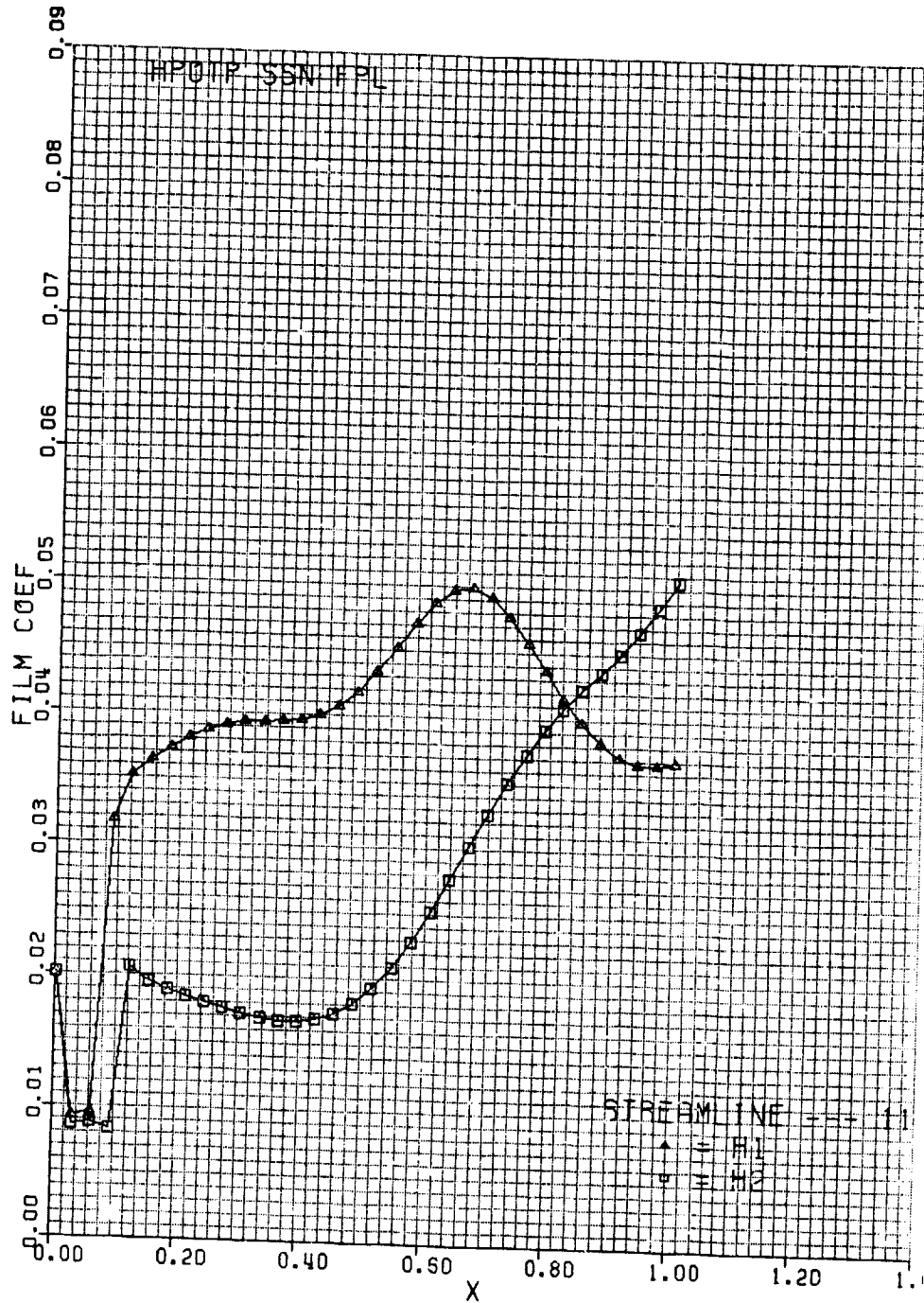

G.3.3

ORIGINAL PAGE IS
OF POOR QUALITY

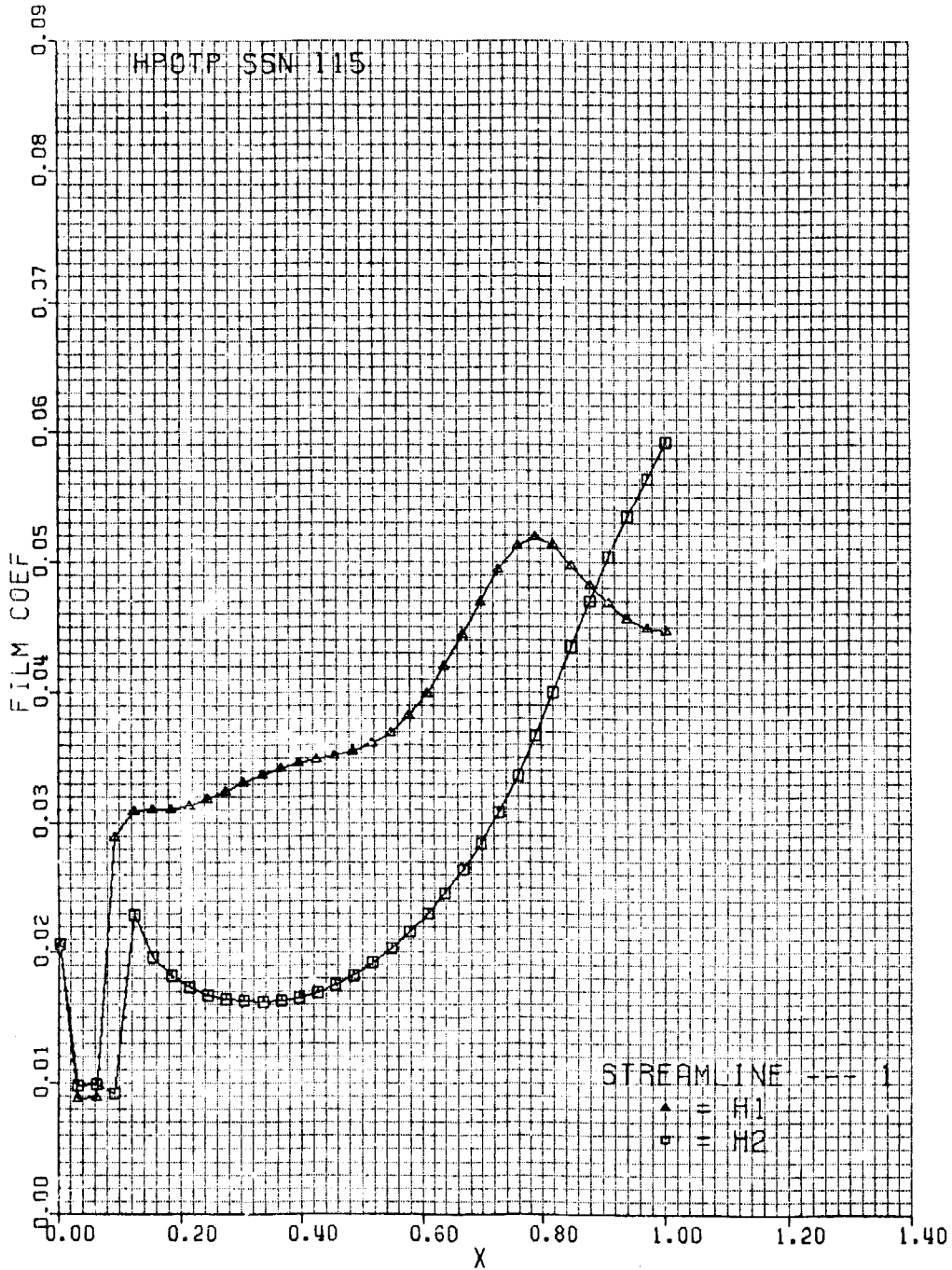

G.4.1

ORIGINAL PAGES
OF POOR QUALITY

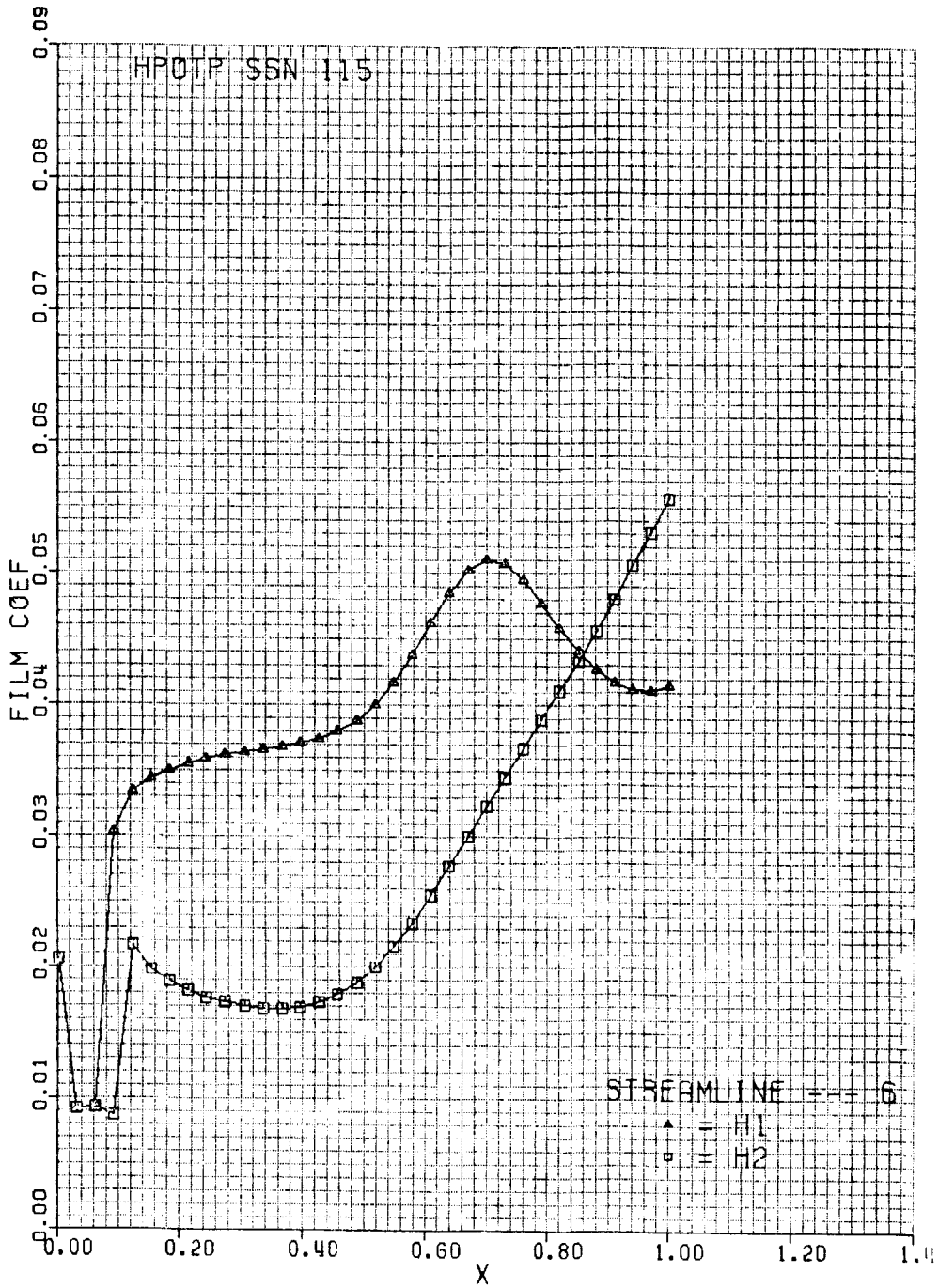

ORIGINAL PAGE IS
OF POOR QUALITY

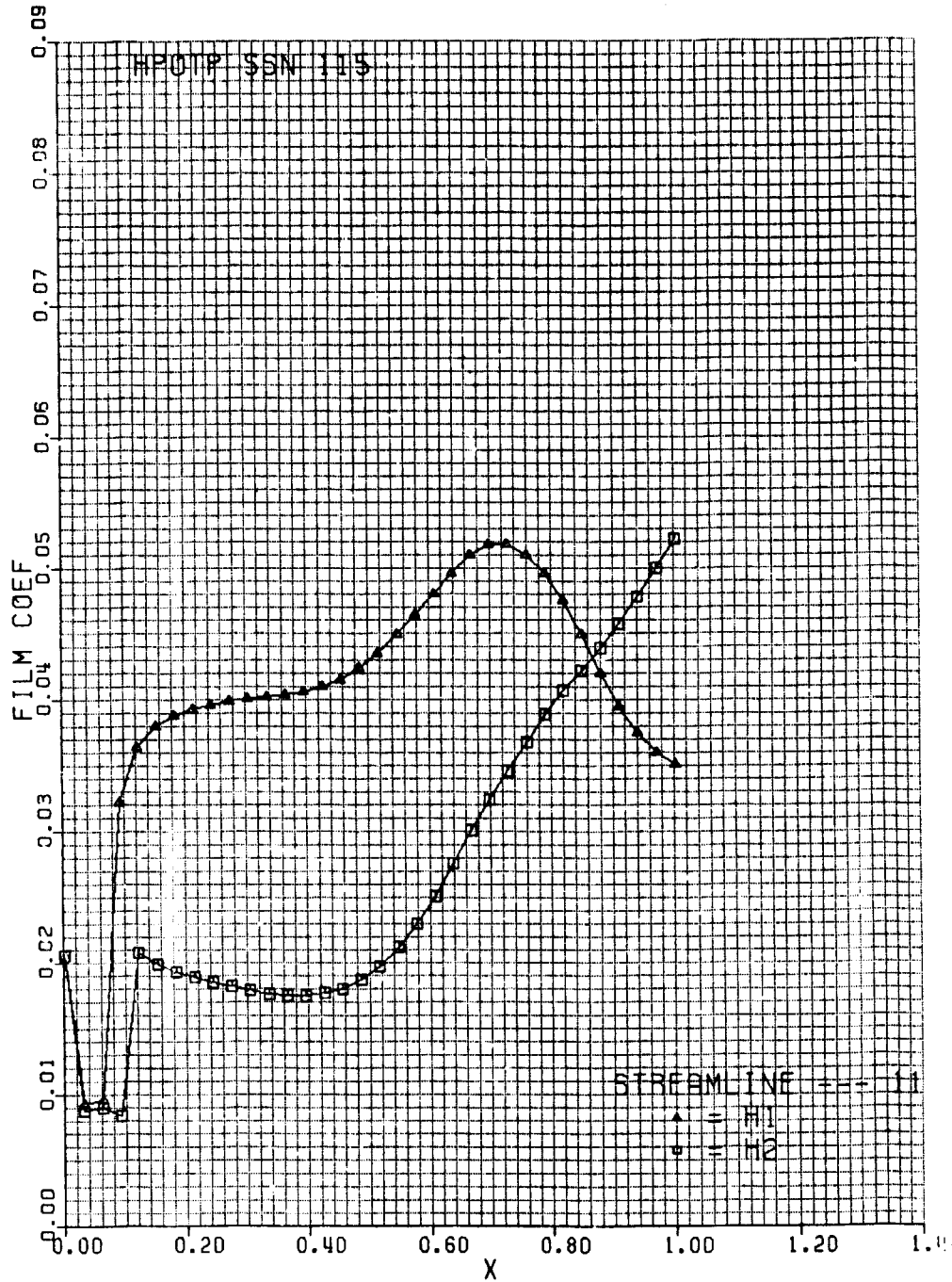

G.4.3

Appendix H

HPOTP SECOND STAGE BLADE PRESSURE, ADIABATIC WALL TEMPERATURE
AND HEAT TRANSFER COEFFICIENT DISTRIBUTIONS

- H.1 FPL Pressure Distributions
- H.2 115 Percent Power Level Pressure Distributions
- H.3 FPL Heat Transfer Coefficients
- H.4 115 Percent Power Level Heat Transfer Coefficients

Surface 1 - Pressure Surface \triangle
 Surface 2 - Suction Surface \square

Approximate Adiabatic Wall
Temperature (F)

	FPL	115 Percent
Streamline 1 - R = 4.703	910	1080
Streamline 6 - R = 5.039	910	1080
Streamline 11 - R = 5.375	910	1080

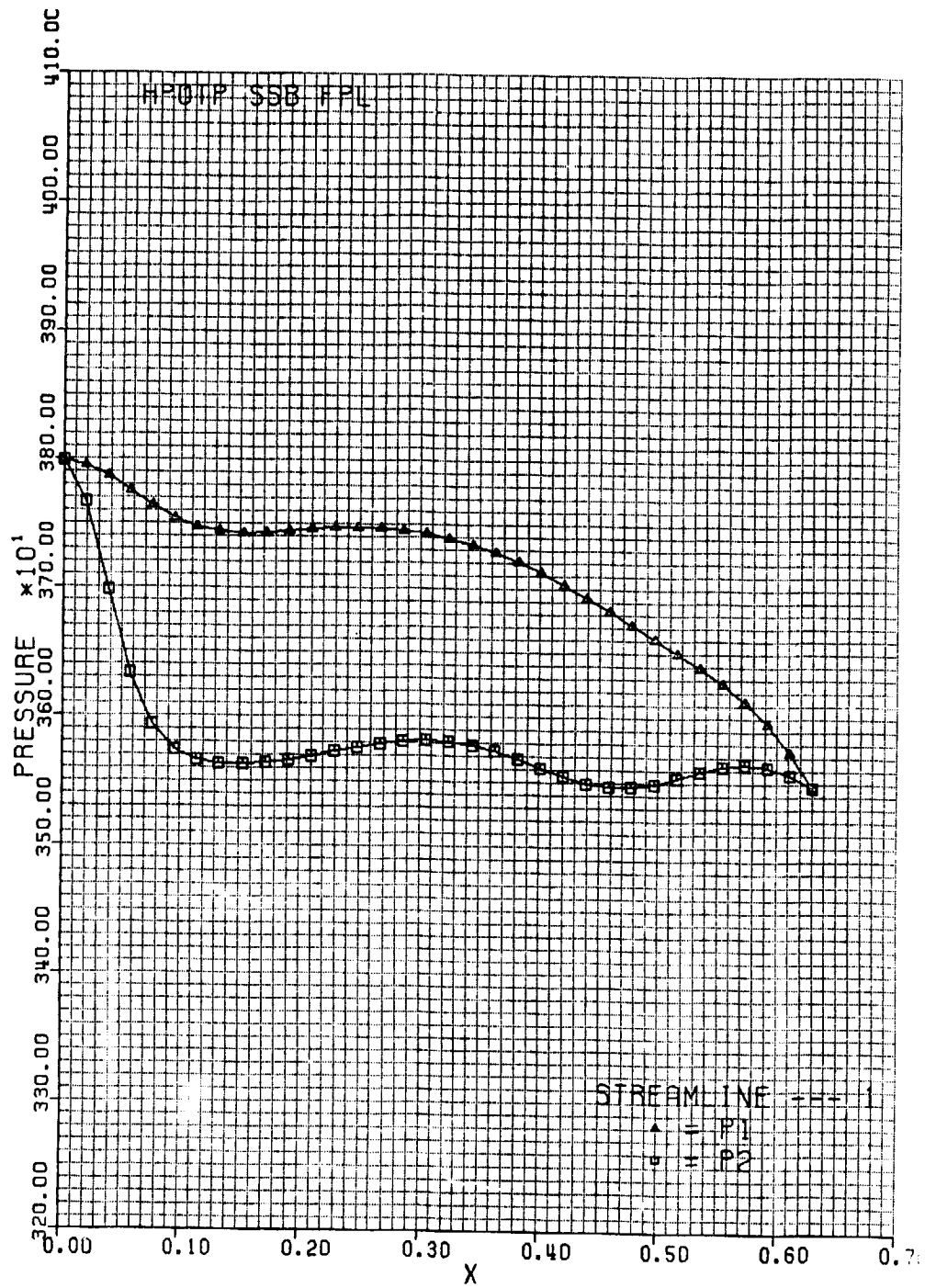

H.1.1

ORIGINAL PAGE IS
OF POOR QUALITY

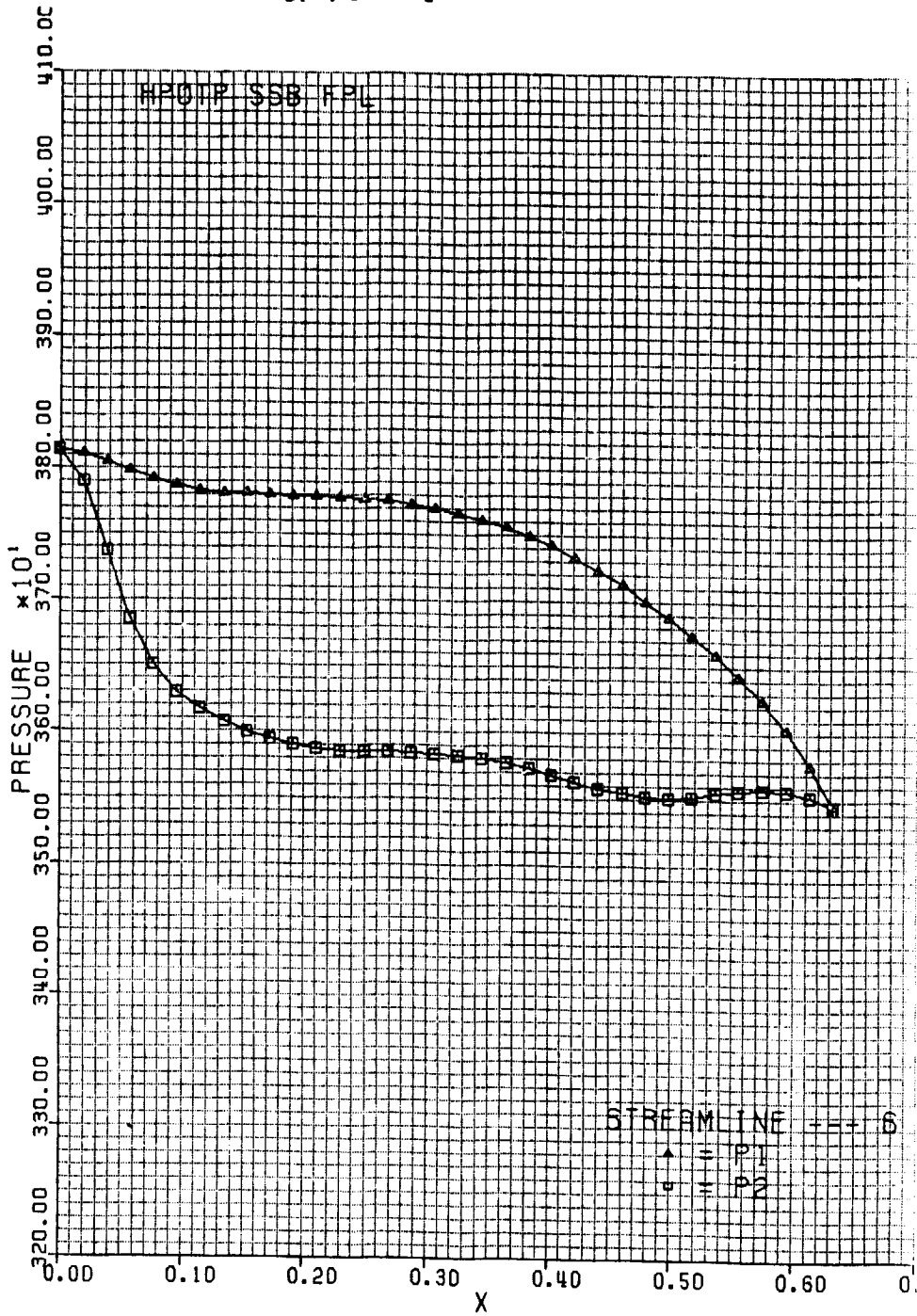

H.1.2

ORIGINAL PAGE IS
OF POOR QUALITY

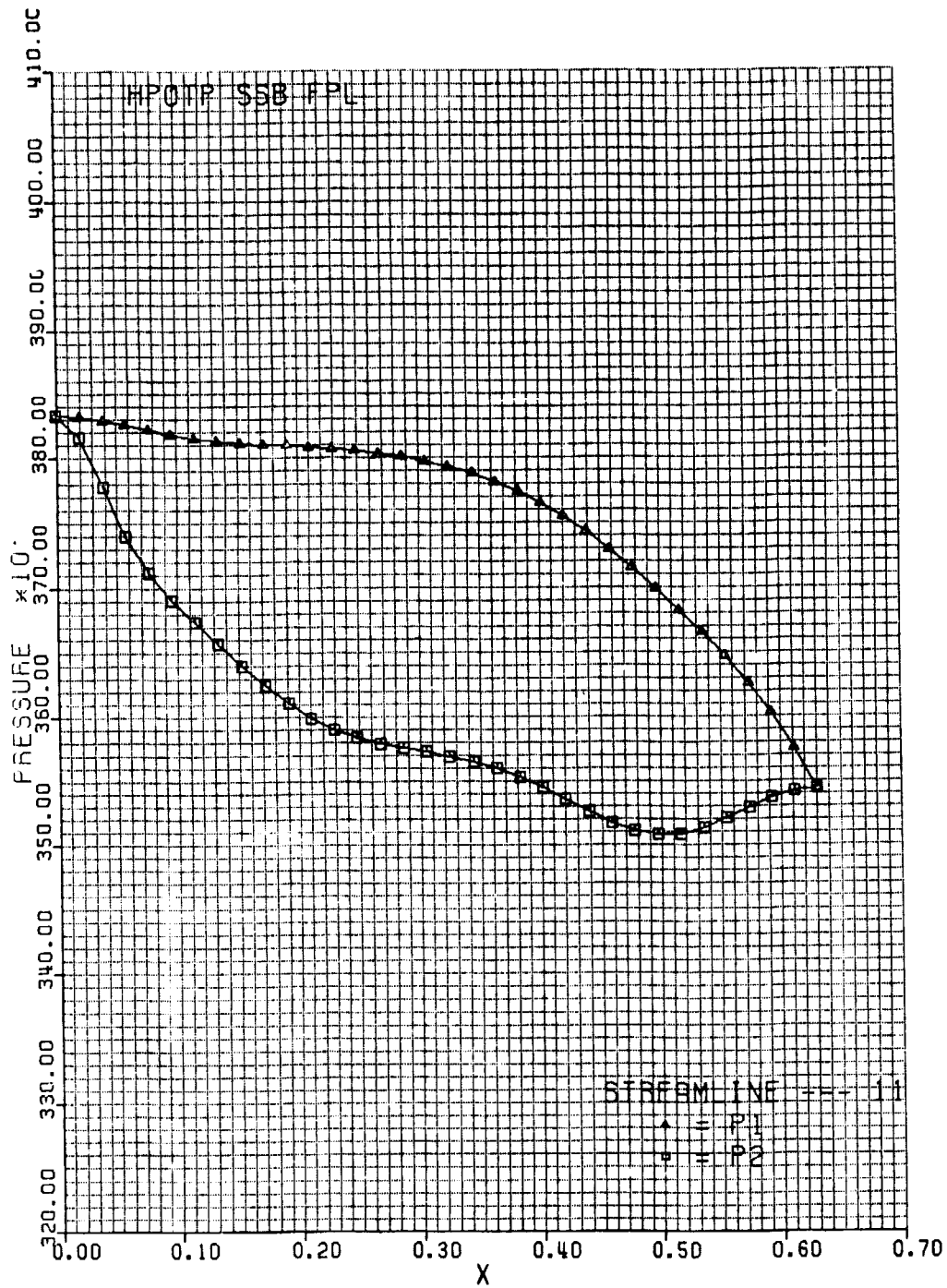

H.1.3

ORIGINAL PAGE IS
OF POOR QUALITY

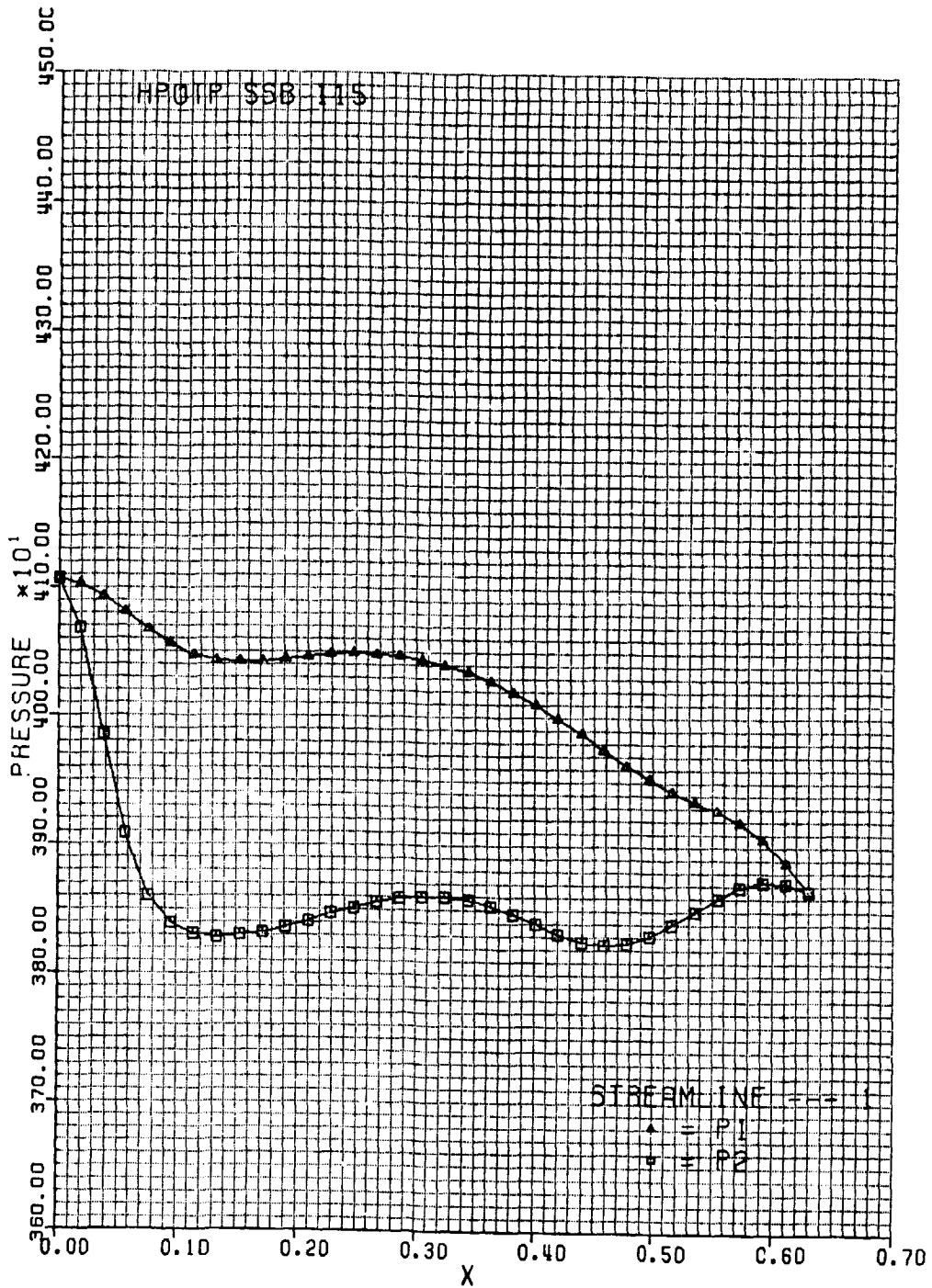

H.2.1

ORIGINAL PAGE IS
OF POOR QUALITY

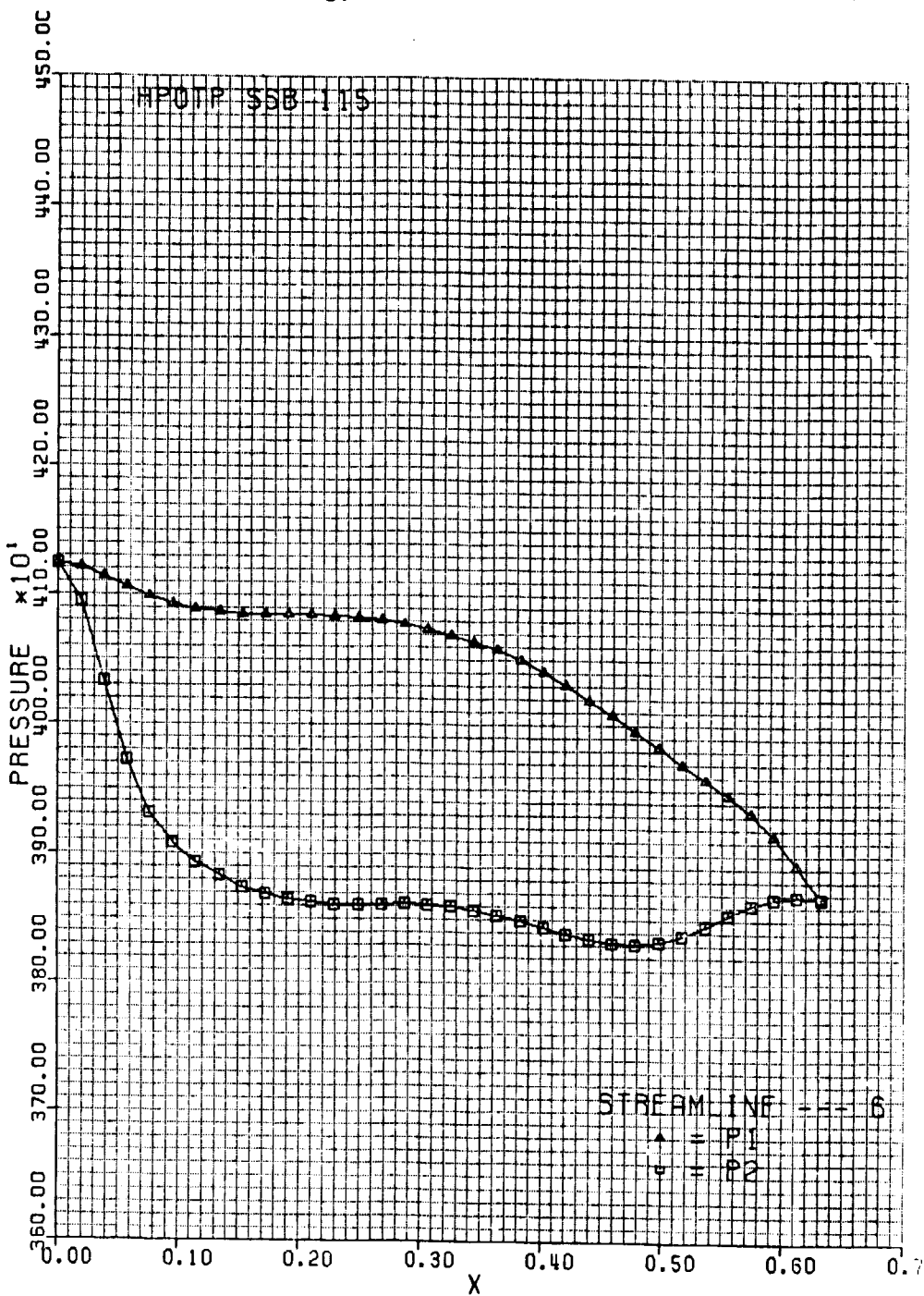

H.2.2

ORIGINAL PAGE IS
OF POOR QUALITY

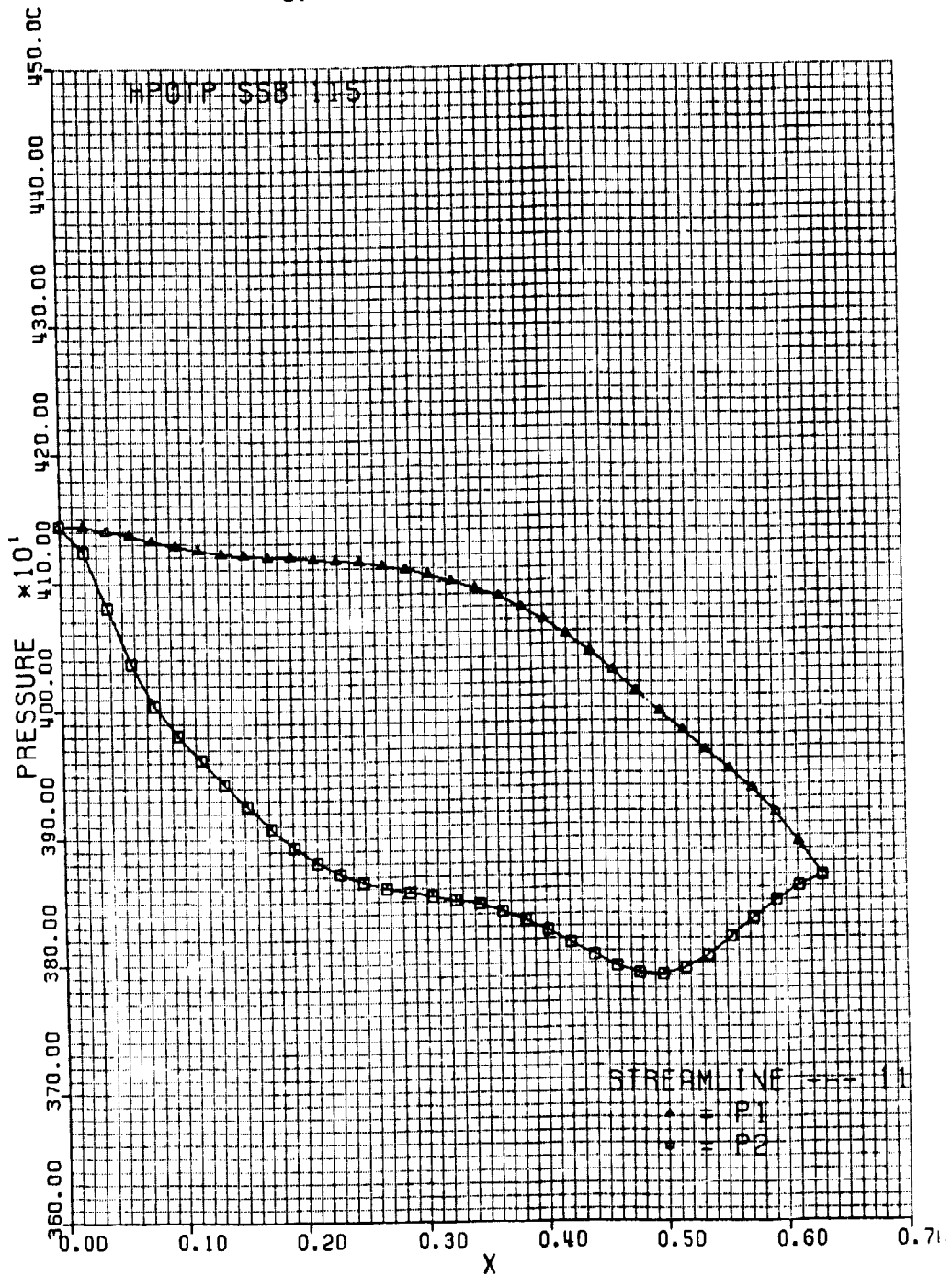

H.2.3

ORIGINAL PAGE 19
OF POOR QUALITY

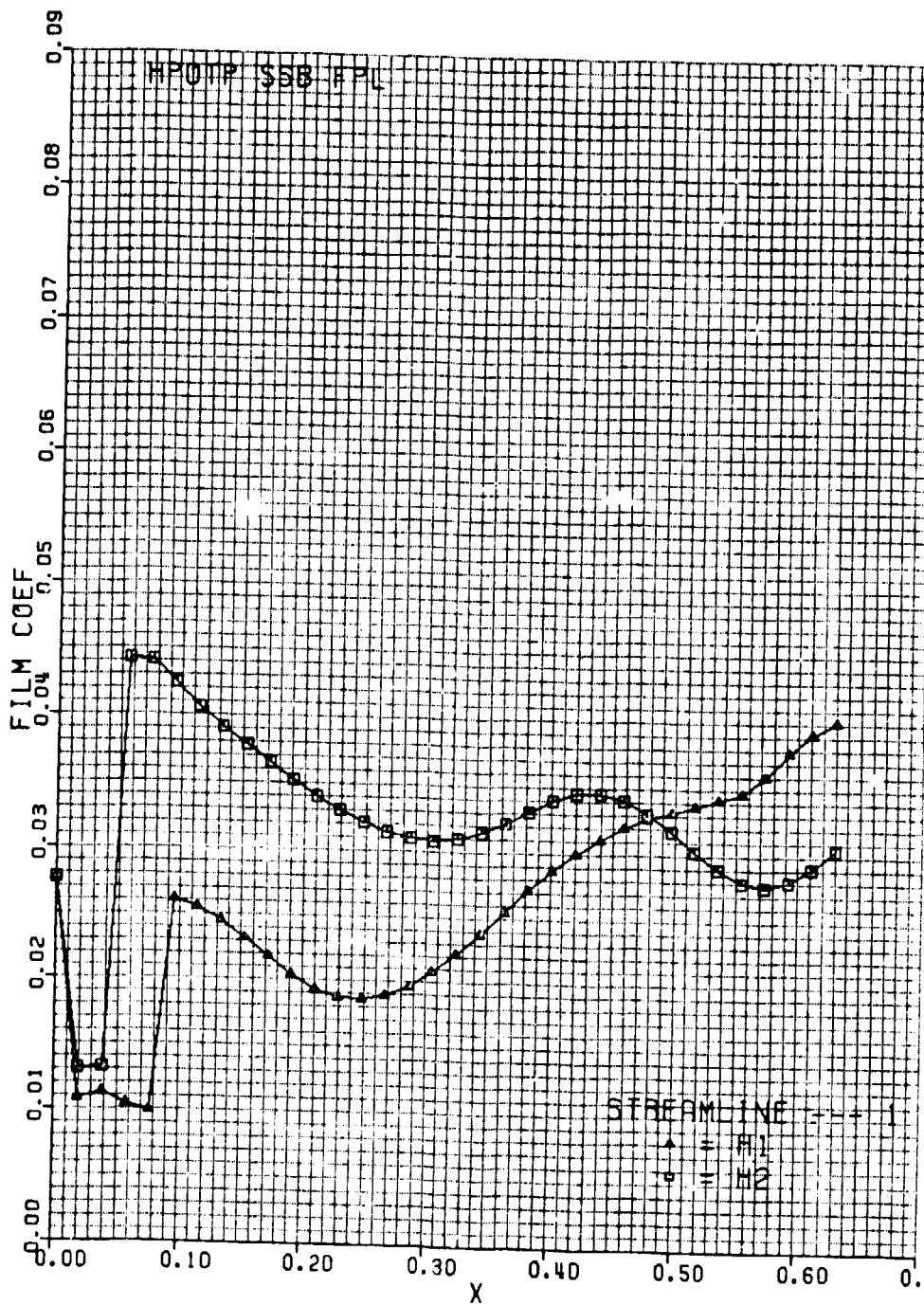

H.3.1

ORIGINAL PAGE IS
OF POOR QUALITY

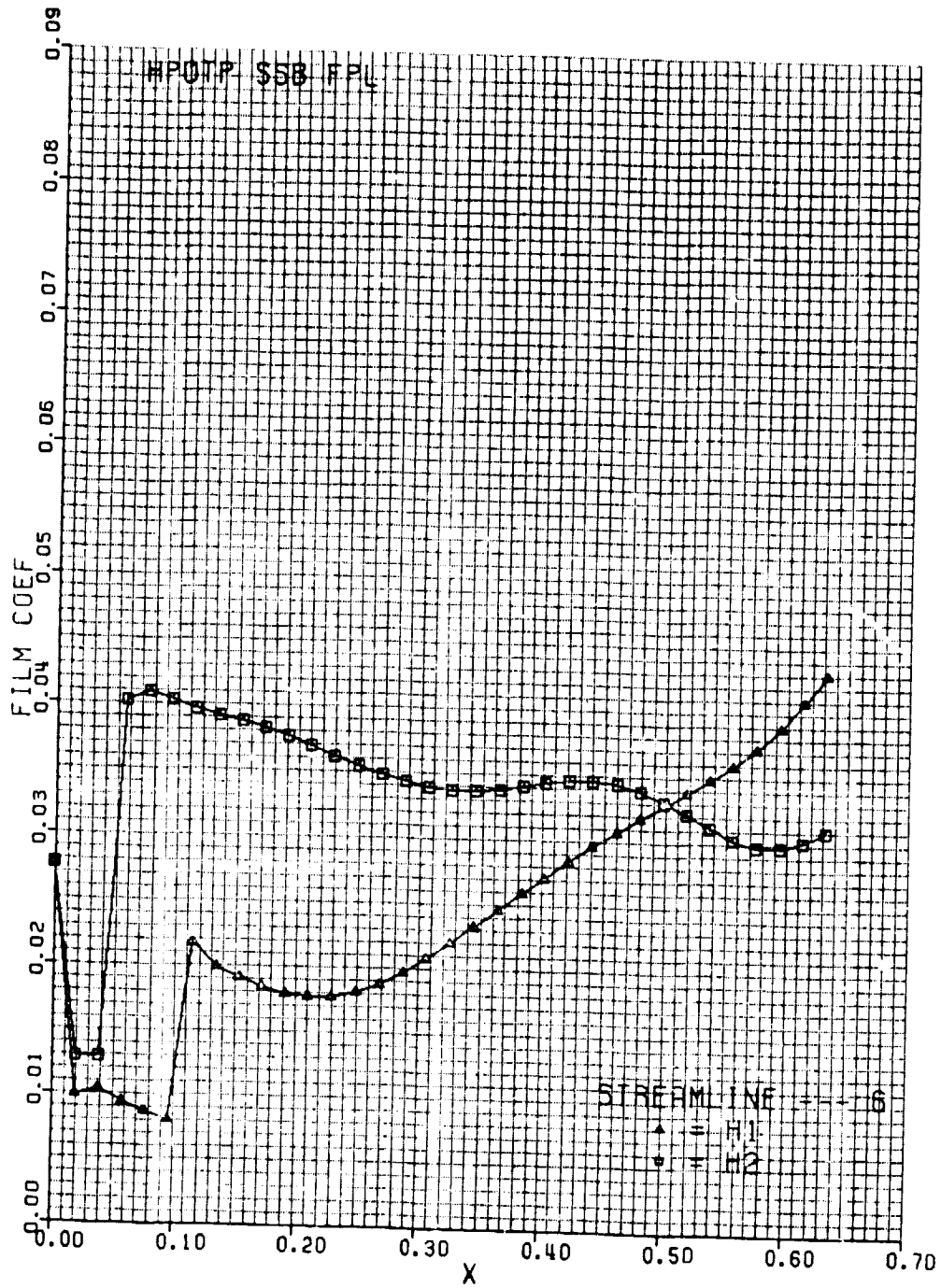

H.3.2

ORIGINAL COPY IS
OF POOR QUALITY

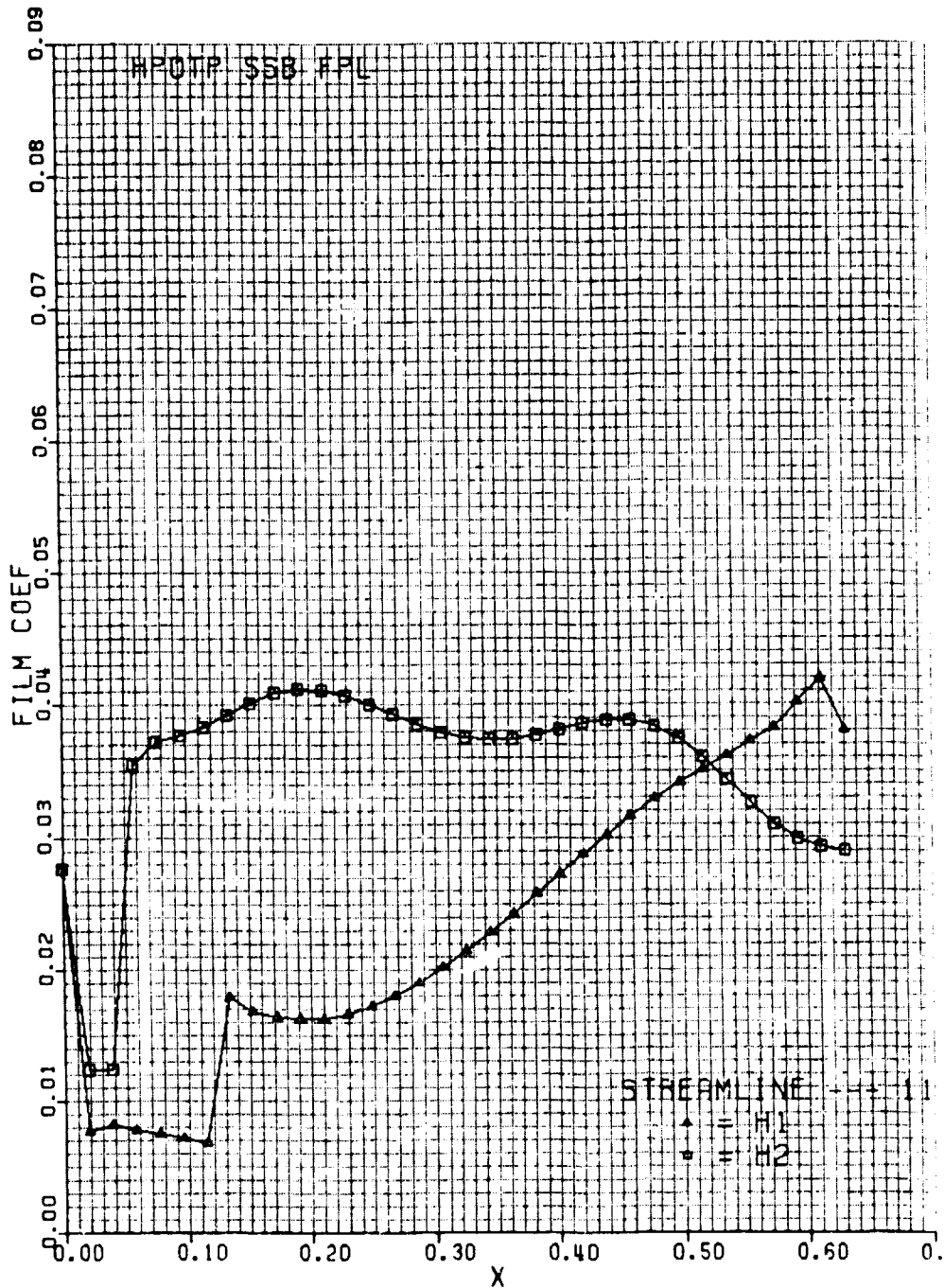

H.3.3

ORIGINAL PAGE IS
OF POOR QUALITY

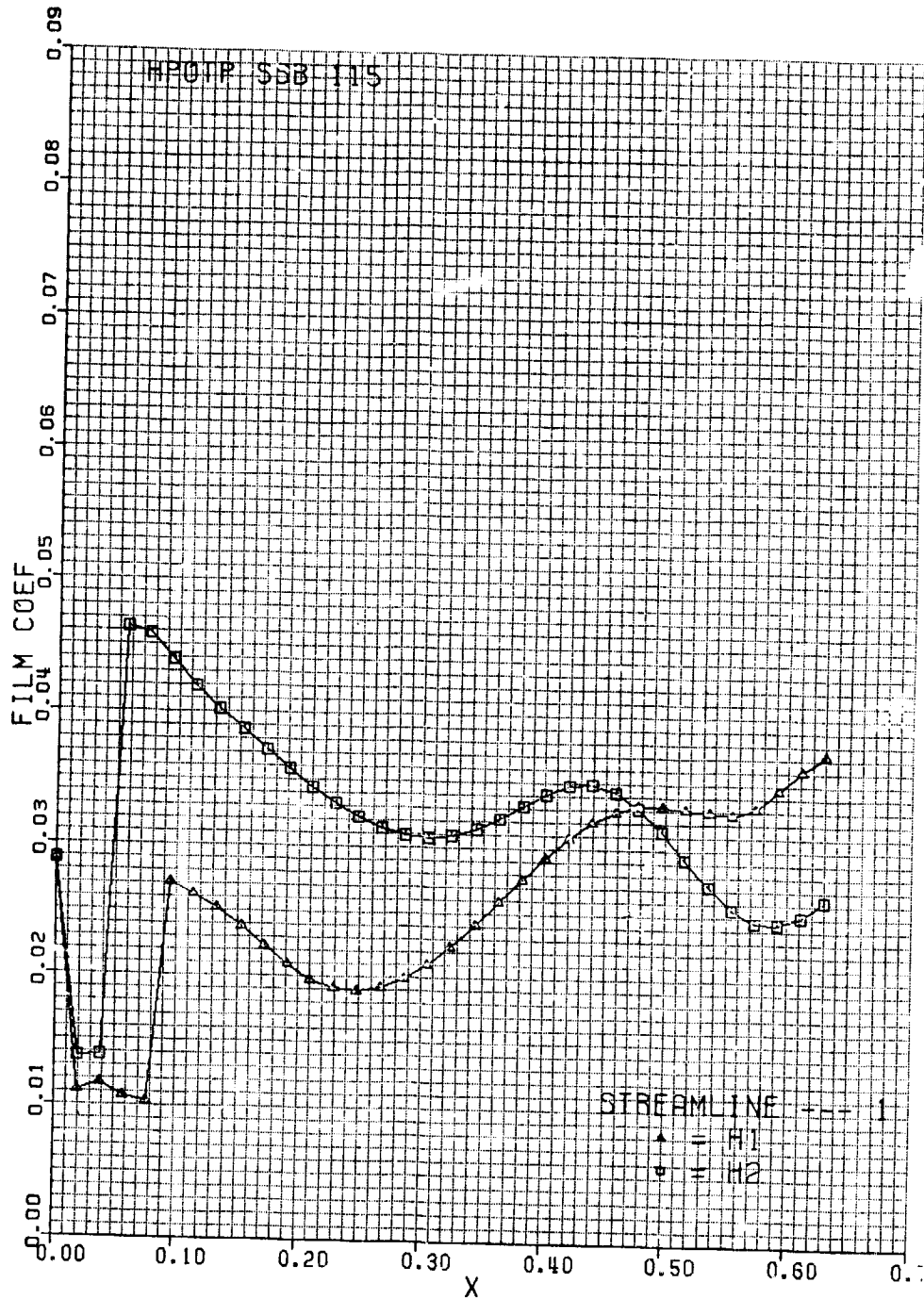

H.4.1

ORIGINAL PAGE IS
OF POOR QUALITY

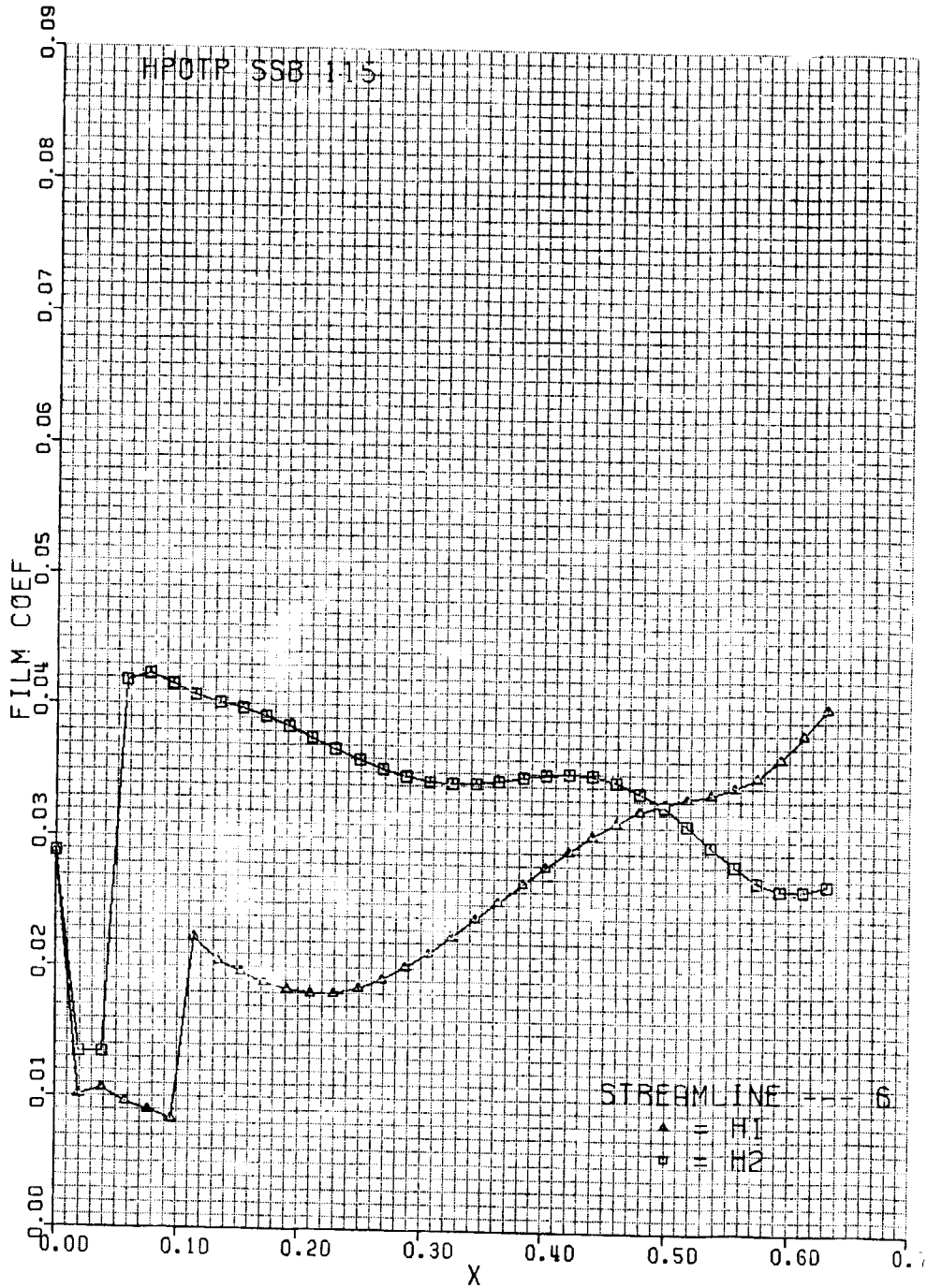

H.4.2

ORIGINAL PAGE IS
OF POOR QUALITY

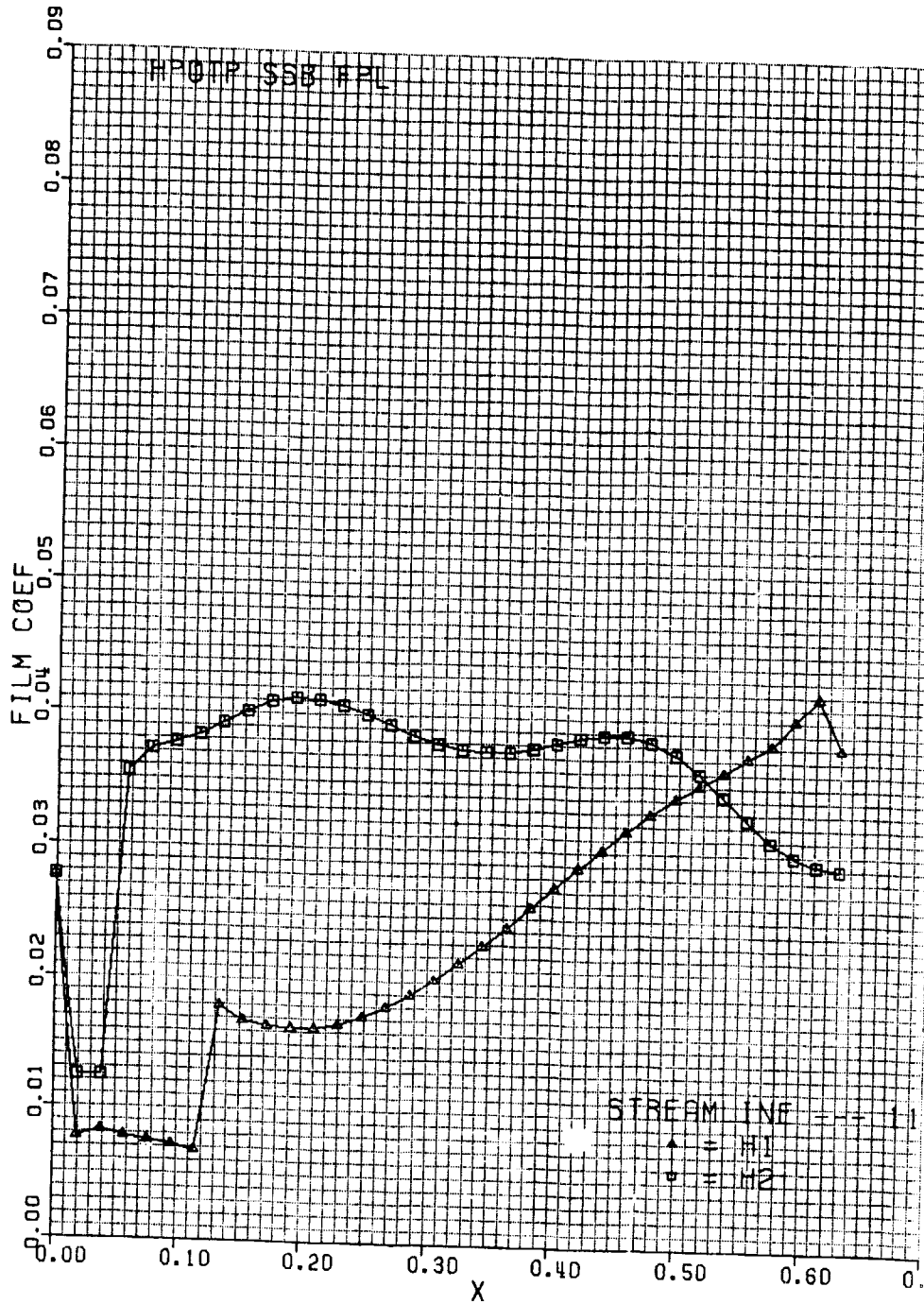

H.4.3