

**NASA
Technical
Paper
2277**

March 1984

NASA-TP-2277 19840012691

Performance of Alkaline
Battery Cells Used in
Emergency Locator Transmitters

Gilbert A. Haynes,
Samuel Sokol,
William R. Motley III,
and Edward L. McClelland

**NASA
Technical
Paper
2277**

1984

Performance of Alkaline
Battery Cells Used in
Emergency Locator Transmitters

Gilbert A. Haynes,
Samuel Sokol,
William R. Motley III,
and Edward L. McClelland

*Langley Research Center
Hampton, Virginia*



National Aeronautics
and Space Administration

Scientific and Technical
Information Branch

Use of trademarks or names of manufacturers in this report does not constitute an official endorsement of such products or manufacturers, either expressed or implied, by the National Aeronautics and Space Administration.

INTRODUCTION

Most general aviation airplanes are required by law to carry emergency locator transmitters (ELT's) that are to be automatically activated if the airplane is involved in a crash. ELT's are self-contained, battery-powered radio beacons that transmit a distinctive signal intended to aid search and rescue activities in locating the crash site. ELT's have experienced an excessive false alarm rate as well as nonactivation problems during crashes. Minimum performance standards were initially established by the Radio Technical Commission for Aeronautics (RTCA) for the Federal Aviation Administration (FAA) in 1970 (ref. 1) and revised in 1979 (ref. 2). However, some of the original and revised standards were made without significant research having been performed to establish the minimum standards, and many problems continue to occur. For example, malfunctions due to battery corrosion effects, human errors, and crash force sensor problems remain among the reported causes for unwanted ELT activations, and nontransmitting ELT's for wanted activations (for the same reasons) have also been reported (refs. 3 and 4). Consequently, the reliability and credibility of ELT's as a useful emergency device have been questioned by the general aviation community.

RTCA Special Committee 136 (RTCA SC 136) was established in 1978 to investigate in more detail the ELT mounting and operations problems. During the investigation, potential ELT battery-power-supply problem areas were identified. These areas included the following:

1. ELT's are required to operate with a specified minimum radio frequency (RF) output for 50 hours or more over the temperature range of -20°C to 55°C . It was not known for certain that alkaline batteries could supply sufficient power at all temperatures in the range for the required time.
2. Exposure to high temperatures (greater than 45°C) continuously for long periods of time is known to shorten battery life. But, the effects on battery life as a result of the stress of extreme diurnal temperature changes (thermal cycling) such as might be encountered in desert areas were not known.
3. Some ELT's use electronic circuits in conjunction with a mechanical crash force sensor to "latch" the ELT in the transmit mode. The electronics must be activated in 11 to 50 milliseconds after the crash force is sensed in order to be latched. It was not known if alkaline batteries suffered a "voltage sag" which might prevent the latch during the activation period.
4. The effect of changes in altitude from sea level to 15.24 km (50 000 ft) and back to sea level on alkaline cell performance was not known.
5. It was not known how alkaline battery cells perform after being subjected to 100g shock forces.
6. ELT's are expected to survive (nonoperational) temperatures as high as 85°C . It was uncertain if all alkaline cells could survive such a temperature exposure without venting or degrading in performance.

A test program was initiated to evaluate alkaline battery cells with respect to the above areas. Cells were procured from the four primary manufacturers who market alkaline zinc/manganese dioxide cells in the United States.

The parameter of primary interest was cell capacity determined as a function of load current, constant temperature, and thermal cycling. The effects of thermal venting and shock were also investigated. These tests and their results constituted the objective of the test program.

One hundred fifty-nine cells from each of the four manufacturers were tested. The manufacturers are identified herein as A, B, C, and D. Several test configurations were assembled (one for each type of test), a digital data-acquisition system was devised, and a data-reduction method was established. The test procedures and techniques, the test results, and an analysis of the results (relative to ELT operations) are presented here. The results are from a statistically small sample (five cells per test) that illustrates the general performance characteristics of these cells.

SYMBOLS AND ABBREVIATIONS

| | |
|---------------------|---|
| DC | direct current |
| DPCA | data processor controller assembly |
| ELT | emergency locator transmitter |
| FAA | Federal Aviation Administration |
| g | acceleration due to gravity (9.8 m/sec^2) |
| I | current |
| LED | light emitting diode |
| P | radio frequency power |
| PERP | peak effective radiated power |
| R_i | resistor |
| R_{sh} | shunt resistor used on cells in test chamber positions 1, 6, 11, 16, 21, 26, 31, and 36 |
| RF | radio frequency |
| RTCA | Radio Technical Commission for Aeronautics |
| SPST | single-pole single-throw |
| T | temperature |
| V_s | voltage source |
| Zn/MnO ₂ | zinc/manganese dioxide |

DERIVATION OF CELL TEST PARAMETERS

The minimum ELT performance standards that are relevant to this investigation include the following (ref. 2):

1. Provide continuous operation for at least 50 hours within the temperature extremes of -20°C to 55°C (-40°C capability is desired, but not required).
2. Transmit an amplitude modulated signal with a modulation factor of at least 0.85 and a duty cycle between 33 percent and 55 percent.
3. Transmit a peak effective radiated power (PERP) of 100 mW at the start and 50 mW at the end of the 50 hours, or not less than 75 mW throughout the 50 hours, on 121.5 MHz and on 243 MHz simultaneously.
4. Automatically sense a crash and be latched on with a crash pulse duration of approximately 10 to 50 milliseconds (dependent on deceleration forces and change in velocity).
5. Survive temperature extremes of -55°C to 85°C , altitudes up to 15.24 km (50 000 ft), and 100g peak shock forces (sinusoidal pulse, 23 ± 2 millisecond duration between zero level points).

Based on the above standards, five ELT's were tested to determine the range of battery load currents and voltages that are required. The ELT's were the following models: Emergency Beacon Corp. EBC-302, Communications Components Corp. CIR-11, Garrett Rescu 88L, Dorne and Margolin ELT 5-2, and Narco ELT-10. Initial, intermediate, and terminal voltages and load currents were obtained to characterize the input voltage and current and RF output power of the ELT's. These tests were conducted at temperatures of -40°C , -20°C , 25°C , 55°C , and 85°C by placing the ELT in a thermally controlled chamber and powering it with a variable-voltage controlled power supply. The initial load currents, which were different for each ELT, ranged from approximately 30 mA to 90 mA. The lowest input voltages that provided 50 mW of RF power were approximately 60 percent to 70 percent of the initial load voltages, depending on the manufacturer and model of the ELT. This is equivalent to 0.9 V to 1.0 V of the minimal rated 1.5 V of an alkaline "D" cell.

To characterize the alkaline cells and include the parametric ranges for ELT operations with slight margins, the following test parameters were selected:

1. Load currents: 30 mA, 65 mA, 100 mA, 150 mA (held constant for each test)
2. Cutoff voltages: 0.8 V, 0.9 V, 1.0 V
3. Temperatures: -40°C , -20°C , 0°C , 20°C , 55°C

One characteristic common to all ELT's tested was that the load current decreased with decreasing power supply voltage. For example, an ELT started operation at an input voltage of 9 V and load current of 32 mA. When the voltage decreased to 7 V, the load current decreased to 26 mA. This characteristic was considered in predicting ELT performance in later tests that are discussed in the "ELT/Battery Tests" section.

TEST PLAN AND EXPERIMENTAL SETUP

The cells tested were zinc/manganese dioxide (Zn/MnO_2) alkaline D cells. Cells from all manufacturers had essentially the same physical dimensions with similar rated performance characteristics. Cells were ordered from manufacturers or distributors at different times such that the cells from any one manufacturer were not from the same batch; hence, they should represent what one would expect when ordering off-the-shelf items. This random selection was expected to result in some scatter in the actual performance data. Upon receipt, the cells were checked for open-circuit voltage and electrolyte leaks and were then stored in a refrigerator at approximately 4°C to minimize aging effects that might be induced by internal chemical activity or self-discharge. The cells were kept in this condition until 24 hours prior to testing, at which time they were removed, allowed to rise to room temperature, and rechecked for open-circuit voltage and electrolyte leaks.

As mentioned above, cell capacity was the parameter of primary interest. The capacity unit is the ampere-hour and, for this case, represents the product of the constant load current and the time required for the cell to discharge such that the cell voltage drops from open circuit (1.5 V) to an ELT-determined minimum level (i.e., 1.0, 0.9, or 0.8 V).

For isothermal tests, cell capacity was measured during exposure to the test temperature. For all other environmental exposures, cells not destroyed were subjected to a capacity test (isothermal) at 20°C after the exposure.

Isothermal Cell Characterization Tests

Isothermal tests were performed to determine the effect of temperature on cell capacity, cell voltage, and cell current. Cells were randomly selected and assembled into sets of five cells from each manufacturer. Because of the limited time allowed for the test program, five cells was the largest number that could be conveniently tested. One 5-cell set from each manufacturer was assembled to form a group of 20 cells. The 20-cell groups were tested two at a time for capacity; different discharge currents were used for each group. The two groups were tested simultaneously at constant load currents of either 150 mA and 100 mA or of 65 mA and 30 mA so that the time differences required to discharge any two groups of cells would be minimized. Capacity tests were performed at temperatures of -40°C , -20°C , 0°C , 20°C , and 55°C . These 12 tests are listed in table I.

The experimental setup for testing cell capacity consisted of a temperature chamber, an electronic load (see appendix), a digital data-acquisition system, battery cell holders, signal conditioning, and related cables, connectors, and terminal boards. Figure 1 shows a block diagram of the test setup. The temperature chamber was a commercially available type capable of holding temperatures within $\pm 0.5^\circ\text{C}$ for long periods of time.

The interconnection and signal-conditioning components consisted of 40 pairs of voltage leads (1 pair per cell), 6 pairs of thermocouple leads (3 per 20-cell group), 5 pairs of current leads and voltage dividers (1 for every fifth cell), and a reference junction to condition the thermocouple output signal.

Thermal Cycle Tests

Since thermal cycling effectively ages alkaline cells, thermal cycle tests were set up to represent an arbitrary worst-case condition for the ELT's located on aircraft. Although literature from the manufacturers states that cells have a shelf life of 3 years, the FAA requires batteries to be replaced in 1 1/2 years. A battery could be subjected to approximately 550 diurnal thermal cycles in 1 1/2 years. The temperature extremes were set to -20°C and 55°C to cover the range of temperatures over which RTCA SC 136 requested information. An ELT would probably not be exposed to such a temperature range for 550 cycles. However, ELT batteries could be exposed to an environment such that these two temperatures could represent the minimum or the maximum point, respectively, in the cycle. Additional real-time data from measurements in aircraft placed in various climatic regions would be required to accurately define a realistic cyclic temperature range.

Thermal cycles of ELT's would normally be 24 hours long. There was not enough time available to permit 24-hour cycles, so the transition time between the temperature extremes was permitted to be that dictated by the normal performance of the chamber, and the dwell times at the temperature extremes were long enough (i.e., 45 minutes) to allow the cells to become stabilized at temperature. Consequently, the cycle time varied from 3.5 hours per cycle to 2.5 hours per cycle, the latter being the cycle rate near the end of the test (after 338 cycles) when fewer cells remained in the chamber. No attempt was made to extrapolate these cycle rates to the more realistic 24-hour rate. The laboratory cycle rate was perhaps less severe than the 24-hour rate because less time was spent at higher temperatures; it was perhaps more severe because of possible increased thermal stresses due to shorter cycles and a very wide temperature range.

Cells from manufacturers A, B, C, and D were cycled. Five cells of each make were removed from cycling after 101, 338, and 536 cycles. The capacity of the cells was then determined by discharging at 20°C and 100-mA load. The reference (no cycle) data were taken from a thermal capacity test in which discharge occurred at 20°C and 100 mA.

Voltage Turn-On Tests

The voltage turn-on tests were conducted to determine if a "voltage-sag" occurs at the instant of cell loading. Should such a sag occur, the batteries may be unable to support an ELT electrical latch immediately after the mechanical g-force sensor engages.

For these tests, the cell groups from all manufacturers were placed in a chamber, brought to a predetermined temperature (-40°C to 55°C), and loaded instantaneously (150 mA) with a knife switch. The voltage characteristics were monitored with a storage oscilloscope, and the resultant display was photographed.

Altitude Tests

The purpose of the altitude tests was to determine and characterize the effects of exposure to low pressure (equivalent to altitudes up to 15.24 km (50 000 ft) on

the capacity of the cells. An unloaded cell group was placed in an altitude chamber and exposed to a predetermined pressure profile. After the exposure, the cells were subjected to a capacity test at 20°C and 100-mA load current.

Mechanical Shock Tests

The purpose of the shock tests was to determine the effect of a 100g shock on the capacity and other characteristics of the cells. Cells from each manufacturer were mounted as shown in figure 2. They were shocked in both directions along the longitudinal axis and once along the transverse axis as shown in figure 3. Different cells from each manufacturer were used for each direction, since the cells are of the primary type and can be discharged only once to determine if there is a weakness associated with a particular axis. After the cells were shocked, they were subjected to a capacity test at 20°C and 100-mA load current.

Thermal Vent Tests

The purpose of the vent tests was to determine if the normally sealed cells would vent (i.e., expel electrolyte or other substances) at or below the 85°C survival temperature. For each test, a five-cell set was placed in a temperature chamber. Ambient temperature of the chamber, cell skin temperature, and open-circuit voltage were monitored. The temperature was increased at a rate of approximately 2°C per minute. The temperature profile indicated the occurrence of venting.

ELT/Battery Tests

Two types of ELT tests were performed. The first test involved determining the operating characteristics (i.e., voltage, current, and RF power) at -40°C, -20°C, 25°C, 55°C, and 85°C. The selected ELT was placed in a temperature chamber, properly instrumented, and powered with an external power supply. The ELT was allowed to stabilize at each temperature before measurements were made.

The second type of ELT test involved placing the selected ELT into the temperature chamber and supplying power to it from an alkaline battery, which was also in the chamber. The battery was assembled using cells from manufacturer B. The test assembly (ELT and battery) was brought to -20°C, stabilized, and permitted to operate for the life of the battery. Parametric measurements were made at regular intervals during the 150-hour test.

EXPERIMENTAL RESULTS AND DISCUSSION

Accuracy

The number of cells used in each test represented a small statistical sample. Five cells from each manufacturer were tested simultaneously. The total number of cells tested was limited by several factors, including the small volume of the environmental chamber, the data-collection capability of the data-acquisition system, and the time available to perform the total series of tests. For these reasons, the test results indicate characteristics that can be expected of cells from a particular manufacturer and should be considered qualitative.

The accuracies of the test measurements as collected by the data-acquisition system with related instrumentation were as follows:

Temperature: $\pm 1^{\circ}\text{C}$

Voltage: $\pm 5\text{ mV}$

Current: $\pm 2\text{ mA}$

Isothermal Cell Characterization Test Results

Characteristic discharge curves representing the average value obtained from five-cell sets from each manufacturer for each test are presented and discussed. Plots of cell capacity, also representing the average value from five-cell sets from each manufacturer, are presented and discussed.

Cells from manufacturer A.— Figures 4(a) through 4(e) show characteristic discharge voltage curves for cells from manufacturer A when discharged at -40°C , -20°C , 0°C , 20°C , and 55°C and at four constant-current loads. These families of curves indicate that the usefulness of the cells apparently increases significantly as the load current is decreased to 30 mA. A measure of the increase in usefulness can be obtained from plots of capacity.

Figures 5(a) through 5(e) show plots of capacity as a function of discharge current for three cutoff voltages. An analysis of the data in these families of curves reveals that the useful capacity increases approximately 16 to 24 percent when the cell load current is decreased from 150 mA to 30 mA at 55°C (fig. 5(a)). The capacity increases by as much as a factor of 2 to 3 for the same load decrease at -20°C (fig. 5(d)). The presence of only a small amount of scatter in the data points indicates that the manufacturing controls were good and permits random selection of these low-cost (\$1.00) production cells. From the raw data, it has been verified that approximately 80 percent of the capacity of the cells has been extracted by the time they have been discharged to 0.9 V.

Figure 6 shows the effects of temperature on cell capacity to 0.9 V under constant loads. Notice that the cell capacity decreases rapidly below 0°C . The cell capacity to 0.9 V with a constant discharge current of 30 mA decreases approximately 40 percent when the temperature is decreased from 0°C to -20°C . This suggests that alkaline batteries will permit satisfactory operation of ELT's for 50 hours only under certain temperature and load conditions. Examples (see fig. 4) of the limitations on successful ELT operation are (0.9-V cutoff)

1. -40°C , load current limited to 30 mA or less
2. -20°C , load current limited to 65 mA or less
3. 0°C to 55°C , load current may be as high as 150 mA (upper limit of tests)

A comparison of figure 6 with figures 5(a) through 5(e) indicates that temperature has a much greater effect on cell capacity than does load current over the temperature and load regimes of these tests. It should also be mentioned that a close examination of all cells after isothermal testing over the temperature range revealed no evidence of leakage or other physical change.

Cells from manufacturer B.— Figures 7(a) through 7(e) show characteristic discharge voltage curves for cells from manufacturer B when discharged at five temperatures and four constant-current loads. As for cells from manufacturer A, the families of curves indicate an apparent significant increase in capacity as the load current is decreased to 30 mA.

Figures 8(a) through 8(e) show plots of capacity as a function of discharge current for three cutoff voltages. An analysis of the data reveals that capacity increases approximately 14 to 34 percent when the cell load current is decreased from 150 mA to 30 mA at 55°C (fig. 8(a)). The capacity increases by as much as a factor of 5 for the same load decrease at -20°C (fig. 8(d)). The presence of only a small amount of scatter in the data indicates that good manufacturing controls were exercised by manufacturer B. From the raw data, it has been verified that approximately 80 percent of the capacity of the cells has been extracted by the time of discharge to 0.9 V.

Figure 9 shows the effects of temperature on cell capacity to 0.9 V under constant-current loads. The cell capacity decreases rapidly below 0°C. The capacity to 0.9 V with a constant discharge current of 30 mA decreases approximately 50 percent when the temperature is decreased from 0°C to -20°C. This suggests that alkaline batteries made of cells from manufacturer B will permit satisfactory operation of ELT's for 50 hours only under certain temperature and load conditions. Examples (see fig. 7) of the limitations on successful ELT operation (0.9-V cutoff) are

1. -40°C, load current limited to 30 mA or less
2. -20°C, load current limited to 65 mA or less
3. 0°C, load current limited to 130 mA or less
4. 20°C to 55°C, load current may be as high as 150 mA (upper limit of tests)

A comparison of figure 9 with figures 8(a) through 8(e) indicates that temperature has a much greater effect on cell capacity than does load current over the temperature and load regimes of these tests. A close examination of all cells after isothermal testing over the temperature range revealed no evidence of leakage or other physical change.

Cells from manufacturer C.— Figures 10(a) through 10(e) show characteristic discharge voltage curves for cells from manufacturer C when discharged at five temperatures and four constant-current loads. As for cells from the other manufacturers, the families of curves indicate an apparent significant increase in capacity as the load current is decreased to 30 mA.

Figures 11(a) through 11(e) show plots of capacity as a function of discharge current for three cutoff voltages. An analysis of the data reveals that capacity increases approximately 12 to 15 percent when the cell discharge rate is decreased from 150 mA to 30 mA at 55°C (fig. 11(a)). The capacity increases by as much as a factor of 3 for the same load decrease at -20°C (fig. 11(d)). The presence of only a small amount of scatter in the data indicates that good manufacturing controls were exercised by manufacturer C. From the raw data, it has been verified that approximately 80 percent of the capacity of the cells has been extracted by the time of discharge to 0.9 V.

Figure 12 shows the effects of temperature on cell capacity to 0.9 V under constant-current loads. The cell capacity decreases rapidly below 0°C. The capacity to 0.9 V with a constant discharge current of 30 mA decreases approximately 37 percent when the temperature is decreased from 0°C to -20°C. This suggests that batteries made of cells from manufacturer C will permit satisfactory operation of ELT's for 50 hours only under certain temperature and load conditions. Examples (see fig. 10) of the limitations on successful ELT operation (0.9-V cutoff) are

1. -40°C, load current limited to 35 mA or less
2. -20°C, load current limited to 85 mA or less
3. 0°C, load current limited to 130 mA or less
4. 20°C to 55°C, load current may be as high as 150 mA (upper limit of tests)

A comparison of figure 12 and figures 11(a) through 11(e) indicates that temperature has a much greater effect on cell capacity than does load current over the temperature and load regimes of these tests. A close examination of all cells after isothermal testing revealed no leakage or physical changes.

Cells from manufacturer D.— Figures 13(a) through 13(e) show characteristic discharge voltage curves for cells from manufacturer D when discharged at five temperatures and four constant-current loads. As for cells from the other manufacturers, the families of curves indicate an apparent significant increase in capacity as the discharge rate is decreased to 30 mA.

Figures 14(a) through 14(e) show plots of capacity as a function of discharge rate for three cutoff voltages. An analysis of the data reveals that capacity increases approximately 30 percent when the cell discharge rate is decreased from 150 mA to 30 mA at 55°C (fig. 14(a)). The capacity increases by as much as a factor of 3 for the same load decrease at -20°C (fig. 14(d)). The presence of only a small amount of scatter in the data indicates that good manufacturing controls were exercised by manufacturer D. From the raw data, it has been verified that approximately 80 percent of the capacity of the cells has been extracted by the time of discharge to 0.9 V.

Figure 15 shows the effects of temperature on cell capacity to 0.9 V under constant-current loads. The cell capacity decreases rapidly below 0°C. The capacity to 0.9 V with a constant discharge current of 30 mA decreases approximately 50 percent when the temperature is decreased from 0°C to -20°C. This suggests that alkaline batteries made of cells from manufacturer D will permit satisfactory operation of ELT's for 50 hours only under certain temperature and load conditions. Examples (see fig. 13) of the limitations on successful ELT operation (0.9-V cutoff) are

1. -40°C, load current limited to 35 mA or less
2. -20°C, load current limited to 85 mA or less
3. 0°C, load current limited to 130 mA or less
4. 20°C to 55°C, load current may be as high as 150 mA (upper limit of tests)

A comparison of figure 15 and figures 14(a) through 14(e) indicates that temperature has a much greater effect on cell capacity than does load current over the temperature and load regimes of these tests. Close examination of all cells after isothermal testing over the temperature range revealed no evidence of leakage or other physical change.

Thermal Cycle Test Results

Three five-cell sets from each manufacturer (60 cells total) were used in the thermal cycle tests. The control (zero cycle) test information was that obtained from the isothermal cell characterization tests at 20°C. A five-cell set of each manufacturer's cells was removed from the chamber after each of three levels of cycling - 101 cycles, 338 cycles, and 536 cycles. The cells were placed directly (within 60 minutes) into the isothermal test chamber, stabilized at 20°C, and discharged at 100 mA to determine capacity.

The thermal cycle profiles to which the cells were exposed are shown in figure 16. The curves in figures 16(a) and 16(b) represent temperature measurements (including ambient chamber temperature) using 12 thermocouples and a multipoint recorder. Figure 16(a) represents the cycle profile in the early portions of the test (cycle no. 90) when 60 cells were in the chamber. Figure 16(b) represents the cycle profile near the end of the test (cycle no. 525) when only 20 cells (less mass) were in the chamber. The dwell times at the temperature extremes remained constant, but the rise and fall times decreased with the mass of the total test specimen. The chamber was not designed (nor modified) for programmable rise and fall times; it heated or cooled at the maximum rate.

Figure 17 shows the effects of thermal cycling on the normalized open-circuit voltage of cells from each manufacturer. The reference values for the normalization were those obtained after 101 cycles. Each point plotted for cells from manufacturers A, C, and D represents an average of five cells. Points plotted for cells from manufacturer B represent the average of three cells for 338 cycles and five cells for 101 and 536 cycles. The nominal decrease of 5 percent or less suggests very little degradation in open-circuit voltage.

Four cells from manufacturer B suffered significant electrolyte leakage after 338 cycles. The open-circuit voltage of two of them had deteriorated significantly; hence, these cells were not used in computing the average open-circuit voltage. One cell from manufacturer D appeared to have leaked but maintained its open-circuit voltage. No other cells (including those from manufacturer B) leaked for the remainder of the cycle tests. It cannot be determined if the five cells that leaked had weaker than normal seals. Consequently, a more comprehensive test is recommended, especially for cells from manufacturer B.

The effects of thermal cycling on the normalized capacity of the cells (to 0.9-V cutoff) are shown in figure 18. Each point plotted for cells from manufacturers A, C, and D represents the average of five cells for each cycle. Data for cells from manufacturer B represent the average of five cells for 101 and 536 cycles, but only one cell is represented for the 338-cycle test point. The data shown in the figure indicate that for cells from manufacturers A, B, and C, the capacity increased after 101 cycles. The increase is most apparent for cells from manufacturer A. It is felt that an analysis should be made to fully understand the causes of such increases.

Further analysis of the data shown indicates that continued thermal cycling decreases the capacity of alkaline cells. After 528 cycles (cycle no. 101 used as basis), the decreases were

1. Cells from manufacturer A, 5 percent
2. Cells from manufacturer B, 12 percent
3. Cells from manufacturer C, 17.5 percent
4. Cells from manufacturer D, 41 percent

Additional testing should be performed on any alkaline cell chosen to power an ELT to determine more precisely the effect of thermal cycling on the cell in the anticipated environment.

Voltage Turn-On Test Results

Turn-on tests were planned to be comprised of five tests - one at each of five temperatures from -40°C to 55°C . The first test was performed at -40°C , which was believed to represent a worst-case condition for the voltage turn-on phenomenon. Five-cell sets from each manufacturer were placed in a special setup described earlier in this report. At the test temperature, no voltage sags were observed upon instantaneous loading of individual cells. This lack of effect held true for all alkaline cells tested at -40°C . The process was repeated at 20°C with the same results. It was assumed that because no effect was noted in the two tests performed, Zn/MnO₂ alkaline cells do not suffer voltage turn-on problems. Consequently, all other tests of this kind were cancelled.

Altitude Test Results

Groups of five-cell sets from each manufacturer were placed in the pressure/vacuum chamber described earlier in this report. The chamber remained at room temperature during the test. The pressure was varied from 760 mm Hg (standard atmospheric sea level pressure) to 87 mm Hg (nominal atmospheric pressure at an altitude of 15.24 km (50 000 ft)) in accordance with the profile shown in figure 19 (1 mm Hg = 133.3 Pa). The pressure was decreased from 760 mm Hg to 87 mm Hg in 5 minutes, remained there for 15 minutes, and was raised to 760 mm Hg in 5 minutes. The capacity of the group of cells was then determined at 20°C and 100-mA discharge rate. The results of the capacity tests indicated that the high-altitude, low-pressure exposure had no effect on cell performance.

Mechanical Shock Test Results

The shock exposure tests consisted of testing three cells from each manufacturer in each of the directions shown in figure 3. The tests required nine cells from each of the four manufacturers. The time history of the shock to which the cells were exposed is shown in figure 20. After shock exposure tests were completed on all cells (36), they were tested for capacity at 20°C and 100-mA discharge rate. The results of the capacity tests indicated that 100g shock applied in the directions tested does not affect Zn/MnO₂ alkaline cell performance.

Thermal Vent Test Results

Five-cell sets from each manufacturer were placed (one set at a time) in the thermal vent test chamber and heated until all cells vented (or until the cell temperature reached 150°C). The chamber temperature was increased at a rate of 2°C per minute to permit the chamber ambient temperature and the cell temperature to rise at approximately the same rate with a minimum difference or lag.

After all cells vented (or the cell temperature reached 150°C), the test was terminated, and a capacity test was performed on each cell at 20°C and 100-mA discharge current. Figure 21 shows typical thermal vent characteristics for cells from manufacturers B, C, and D.

Cells from manufacturer C vented at temperatures between 61°C and 66°C. The venting activity lasted for 12 to 67 seconds, after which the vent mechanism apparently closed. The open-circuit voltage, which was normal before the test, was found to have decreased significantly when rechecked at room temperature after the test.

Cells from manufacturer B vented at temperatures between 85°C and 93°C. The venting activity lasted for approximately 10 seconds for all cells. The open-circuit voltage showed a significant decrease when rechecked at room temperature after the test.

Cells from manufacturer D vented at temperatures between 113°C and 125°C. The venting activity lasted for as long as 1.4 minutes. The open-circuit voltage had decreased significantly when rechecked at room temperature after the test.

Cells from manufacturer A did not show a temperature indication of venting at temperatures up to 150°C (test terminated). However, at temperatures above 100°C, the open-circuit voltage became erratic. The open-circuit voltage was found to have decreased only slightly when rechecked at room temperature after the test. Visual observation indicated that the cells did vent.

The capacity test results for all cells were inconclusive. There was no consistency in the capacity for any cell set, except that it had decreased significantly. It is, therefore, assumed that cells are not usable after occurrence of thermal venting. It is also assumed that the cells will continue to leak after thermal venting occurs, since the seal cannot be expected to close properly. The occurrence of cell thermal venting in an ELT would require immediate removal of the battery because of the corrosive nature of the electrolyte.

ELT/Battery Test Results

Five ELT's were tested (as a part of another related test program) to characterize the DC input current and RF power output as functions of the DC input voltage at temperatures of -40°C, -20°C, 25°C, and 55°C. The tests were conducted with a variable-voltage power supply (in lieu of alkaline batteries) located external to the temperature chamber in which the ELT's were placed. The test results were used to select a typical ELT on which to perform a real-time ELT/battery test under worst-case temperature conditions (-20°C). Such tests permitted determination of whether an alkaline battery could or could not support proper ELT operation under worst-case temperature conditions for the required 50 hours; they also provided a data point to be used as a basis for comparison of the structured tests and tests under actual operating conditions.

Some of the more important specifications taken from the ELT performance data sheet for the selected ELT are cited below:

1. Operating frequencies: 121.5 MHz and 243 MHz simultaneously
2. Modulation: Amplitude modulation of 100-percent square wave; swept tone over a range of 700 Hz within the band from 1600 Hz to 300 Hz; sweep repetition rate of 2 to 4; typical modulation factor of 100 percent; typical duty cycle of 33 1/3 percent
3. Transmitter duty cycle: Continuous
4. PERP (peak effective radiated power or RF output power): Typically, 100 mW on each frequency (at 20°C)

These characteristics indicate that the RF transmission is a carrier, amplitude modulated for approximately 1/3 of each second of transmission time, and the amplitude of the modulation signal is approximately equal to the amplitude of the carrier signal. An oscillograph recording (not presented) showed a constant amplitude current is required for latching and timing circuits, oscillators, and amplifiers, and a pulsating current is required for the modulator during the modulation period.

Results of the ELT characterization tests that apply to the selected unit are given in table II. The data indicate that the ELT drew 34 mA to 38 mA load current (beginning of test) at 9.0 V. It is also indicated that the RF output power remained above 50 mW when the ELT voltage was set at 6.0 V.

As a part of the battery cell performance tests, a six-cell battery (nominal 9.0 V) made from manufacturer B cells was fabricated and used to supply power to the selected ELT. The ELT/battery combination was placed in a temperature chamber and instrumented for measurements of voltage, current, and RF power output. The temperature was stabilized at -20°C; the ELT was then turned on and allowed to operate continuously until the RF power degraded to less than 50 mW. The RF power and the current were measured periodically (usually during normal working hours), and the voltage was measured continuously. The starting discharge current and voltage were 34 mA and 9.0 V, respectively.

The results of the ELT/battery tests are shown in figure 22. Both the load voltage (solid line) and the load current (long-dashed line) are shown. A third curve (short-dashed line) is also shown; this curve was computed from individual cell data acquired during isothermal cell characterization tests. The ELT/battery tests were terminated after 150 hours of continuous operation, since the FAA minimum requirement of 50 hours had been far exceeded, and the RF power output had not decreased to 50 mW. The load current and voltage curves show that at 150 hours, the battery voltage was still well above the 6.0-V minimum that was established from the ELT tests. The computed curve indicates that at a constant current of 30 mA, more than 120 hours would have been required to reach 6.0 V (the minimum voltage required to provide 50 mW of RF power). This also far exceeds the FAA minimum requirement. The computed results, when compared with actual results, indicate that ELT/battery systems designed with the battery cell constant-current results of this report will result in conservative systems relative to length of operation at the minimum required temperature of -20°C.

CONCLUSIONS

The characteristics of battery power supplies for emergency locator transmitters (ELT's) were investigated by testing alkaline zinc/manganese dioxide (Zn/MnO₂) cells of the type typically used in ELT's. Cells from four manufacturers were tested. The cells were subjected to simulated environmental and load conditions representative of those required for survival and operation. The objective of the study was to evaluate battery cell characteristics that are indicative of the ability of the cell to support proper ELT operation under certain worst-case conditions. ELT problem areas that dictated the tests be performed included the following:

1. ELT's are required to operate with a specified minimum radio frequency (RF) output for 50 hours or more over the temperature range of -20°C to 55°C. It was not known for certain that alkaline batteries could supply sufficient power at all temperatures in the range for the required time.
2. Exposure to high temperatures (greater than 45°C) continuously for long periods of time is known to shorten battery life. But, the effects on battery life as a result of the stress of extreme diurnal temperature changes (thermal cycling) such as might be encountered in desert areas were not known.
3. Some ELT's use electronic circuits in conjunction with a mechanical crash force sensor to "latch" the ELT in the transmit mode. The electronics must be activated in 11 to 50 milliseconds after the crash force is sensed in order to be latched. It was not known if alkaline batteries suffered a "voltage sag" which might prevent the latch during the activation period.
4. The effect of changes in altitude from sea level to 15.24 km (50 000 ft) and back to sea level on alkaline cell performance was not known.
5. It was not known how alkaline battery cells perform after being subjected to 100g shock forces.
6. ELT's are expected to survive (nonoperational) temperatures as high as 85°C. It was uncertain if all alkaline cells could survive such a temperature exposure without venting or degrading in performance.
7. Although not a requirement, operation of ELT's at -40°C was of interest. It was not known if alkaline cells would support such operation.
8. Tests were run on an ELT powered by an alkaline battery at -20°C for the purpose of acquiring a data point for comparison of structured tests and tests under actual operating conditions.

It was found as a result of the investigation that alkaline Zn/MnO₂ cells as a class have sufficient capability relative to many of the problem areas. The cells are marginal or unsatisfactory in some areas. The following paragraphs cite the results in the order of the eight problem areas identified above:

1. Isothermal tests were conducted to determine cell performance over the temperature range of -20°C to 55°C. The results indicate that all manufacturers' cells would supply the power (at constant load) required for 50 hours of satisfactory operation for ELT's that operate on 65 mA or less. Cells from manufacturers C and D will permit constant load operation up to 85 mA. For ELT's that operate at less than

constant load (less than 100-percent duty cycle), the operating load current could be increased. Also, as the temperature is increased above -20°C , the available capacity increases.

2. The investigation indicates that capacity is affected when alkaline cells are thermally cycled between -20°C and 55°C . The capacity of the cells degraded by 5 to 41 percent after 528 cycles. (Cycle no. 101 was used as the basis.) Electrolyte leakage was found in some cells from manufacturers B and D after 338 cycles. Cells that develop leaks suffer degradation in open-circuit voltage and capacity.

3. Alkaline cells (Zn/MnO_2) do not suffer a "voltage sag" as a result of instantaneous loading (150-mA maximum). This is true over the temperature range of -40° to 55°C .

4. Exposure of alkaline cells to low pressures equivalent to those found at an altitude of 15.24 km (50 000 ft) causes no measurable effect in cell performance.

5. Exposure of alkaline cells to a 100g shock in the three directions tested causes no measurable effect on cell voltage or capacity.

6. The following results of thermal vent tests indicate that some cells could not survive exposure to 85°C :

- a. Cells from manufacturer C vented at temperatures of 61°C to 66°C .
- b. Cells from manufacturer B vented at temperatures of 85°C to 93°C .
- c. Cells from manufacturer D vented at temperatures of 113°C and higher.
- d. Cells from manufacturer A did not show a temperature indication of venting below 150°C .

7. Isothermal tests at -40°C indicate that alkaline cells will supply the power (at constant current) required for 50 hours of satisfactory operation for ELT's that operate on 30 mA or less.

8. ELT/battery test results indicate that at -20°C , alkaline batteries can be expected to support operation of the ELT for more than the 50-hour FAA minimum requirement.

In conclusion, alkaline battery cell characteristics have been found to be such that proper ELT operation can be supported under FAA worst-case conditions provided proper attention is given to environmental conditions during design.

Langley Research Center
National Aeronautics and Space Administration
Hampton, VA 23665
January 31, 1984

APPENDIX

CONSTANT-CURRENT LOAD CIRCUIT AND DATA HANDLING

Introduction

The circuit configuration for testing cell capacity is shown in figure 1. This setup provides a variable resistive load which draws a constant current from each cell independent of the cell voltage and independent of the circuitry that conditions the current and voltage data for recording on digital magnetic tape. The constant load circuit and data-handling system are described below.

Load Circuit

The constant-current load circuit is shown in figure A1. This circuit was designed to provide a predictable discharge rate that is independent of the cell terminal voltage. There is a separate circuit for each cell. The circuit features a ground-referenced current-sensing resistor (R_4 , 0.25Ω) to provide negative feedback to an inverting amplifier formed by an operational amplifier (AD 741) driving a power transistor (2N5878). The base current to the power transistor is limited by resistor R_5 ($1 \text{ k}\Omega$) and an LED (light emitting diode), which is mounted on the front panel and is visible to the test operator. The LED brightness increases considerably as a cell discharges and serves as a useful visual end-of-test indicator. The magnitude of the cell test current is determined by a voltage source V_s introduced from the input to ground. The gain of the active devices in conjunction with the ratio $R_1/(R_2 + R_3)$ maintains a scaled version of the input voltage across R_4 . Thus, the circuit maintained a load current that was proportional to the input voltage. The gain constant was adjusted by R_2 and, for convenience, a value of $1 \text{ V}/100 \text{ mA}$ was used. Resistor R_6 was used to nullify any residual offset from the system. The input voltage for the load circuits was derived from a voltage standard to ensure stability, resolution, and resetability of the load current.

Load-Circuit Characteristics

Several important load-circuit parameters were evaluated during the design phase. Temperature effects were not considered because the load circuits were operated in a laboratory where the ambient temperature was constant to $\pm 4^\circ\text{C}$. The long-term aging (several days or weeks) effect on the offset and gain stability of the circuit components was typically $\pm 2\text{-mA}$ deviation from the expected load current. During cell testing, some of the adjustment potentiometers exhibited gross changes in their performance. (The failures were attributed to stresses induced during circuit fabrication.) Data taken with a failed load circuit were discarded, the fault was isolated and repaired, the system was returned to service, and tests on new cells were rerun. Current calibration was performed periodically to verify performance.

The load circuit performed well over the range of 30 to 1000 mA of load current. The minimum cell voltage necessary to enable the load circuit to maintain load current regulation is a function of the selected value of load current. The minimum compliance voltage ranged from 0.2 V with a load current of 30 to 50 mA to 0.45 V with a 500-mA load current. This range was well below the end-of-life cell voltage of 0.7 V and was considered adequate for the requirements of the cell evaluation program which required constant load currents of 30, 65, 100, and 150 mA.

APPENDIX

Data Processing, Control, and Recording

A data processor controller assembly (DPCA) provided a timer which allows the periodic sampling of 64 analog inputs, converts the samples to a 12-bit digital format, and writes the resulting data on magnetic tape. A 24-bit sync pattern, a 24-bit time code, and a 24-bit postsync pattern are inserted into the data stream to aid the user during data reduction. The DPCA timer was programmed to sample all data sources every 2 minutes and 37 seconds. The data introduced into the DPCA included gain and offset measurements of the analog subsystem. This allowed self-calibration of the data system and subsequent data correction during data reduction. The resulting system uncertainty is 0.3 percent of the new cell voltage, or approximately 5 mV.

The computer-compatible tape interface accepted the serial digital data from the DPCA and wrote groups of 8 successive bits as one word across the width of the 9-track magnetic tape. The ninth track was used to write a parity bit generated within the tape recorder. The selected recorder with 512-character data buffers was used because it offered almost complete data rate flexibility. During data reduction, the successive 8-bit characters written on tape were reassembled into the original serial data stream, the sync patterns were located, and the data words were decommutated.

REFERENCES

1. RTCA SC-119: Minimum Performance Standards - Emergency Locator Transmitters. Doc. No. DO-147, Radio Tech. Comm. Aeronaut., Nov. 1970.
2. RTCA SC-127: Minimum Performance Standards - Emergency Locator Transmitters. Doc. No. DO-168, Radio Tech. Comm. Aeronaut., Jan. 1979.
3. Special Study - Emergency Locator Transmitters: An Overview. Rep. No. NTSB-AAS-78-1, Jan. 26, 1978.
4. Toth, S.; and Gershkoff, I.: Control of ELT False Alarms. Publ. 1362-01-1-2032 (Contract NASW-3229), ARINC Res. Corp., Oct. 1979. (Available as NASA CR-162502.)

TABLE I.- ALKALINE BATTERY CELL CAPACITY TESTS

| Test no. | Capacity test | Temperature, °C | No. cells | Load current, mA |
|----------|-------------------------------------|-----------------|-----------|------------------|
| 1 | Isothermal | 55 | 40 | 100/150 |
| 2 | Isothermal | -20 | 40 | 100/150 |
| 3 | Post-thermal-cycle | 20 | 20 | 100 |
| 4 | Isothermal | 20 | 40 | 100/150 |
| 5 | Isothermal | 20 | 40 | 100/150 |
| 6 | Isothermal | -40 | 40 | 30/65 |
| 7 | Isothermal | 0 | 40 | 100/150 |
| 8 | Isothermal | -40 | 40 | 100/150 |
| 9 | Isothermal | -20 | 40 | 30/65 |
| 10 | Post-altitude or post-thermal-cycle | 20 | 40 | 100 |
| 11 | Isothermal | 0 | 40 | 30/65 |
| 12 | Post-thermal-cycle | 20 | 20 | 100 |
| 13 | Isothermal | 20 | 40 | 30/65 |
| 14 | Post-thermal-vent | 55 | 20 | 100 |
| 15 | Isothermal | 55 | 40 | 30/65 |
| 16 | Isothermal | 0 | 40 | 30/65 |
| 17 | Post-shock | 20 | 36 | 100 |
| 18 | Post-thermal-vent | 55 | 20 | 100 |

TABLE II.- ELT TEST RESULTS

| Voltage, V | -40°C | | -20°C | | 25°C | | 55°C | | 85°C | |
|------------|-------|-------|-------|-------|-------|-------|-------|-------|-------|-------|
| | I, mA | P, mW | I, mA | P, mW | I, mA | P, mW | I, mA | P, mW | I, mA | P, mW |
| 9.0 | 34 | 149 | 34 | 140 | 35 | 146 | 36 | 133 | 38 | 122 |
| 8.5 | 32 | 135 | 32 | 125 | 33 | 134 | 33 | 123 | | |
| 8.0 | 29 | 125 | 28 | 105 | 30 | 118 | 31 | 109 | 33 | 98 |
| 7.0 | 24 | 85 | 23 | 80 | 28 | 87 | 26 | 80 | 26 | 75 |
| 6.0 | 20 | 61 | 19 | 55 | 21 | 62 | 20 | 58 | 20 | 55 |
| 5.0 | 20 | 37 | 16 | 30 | 16 | 37 | 14 | 36 | | |

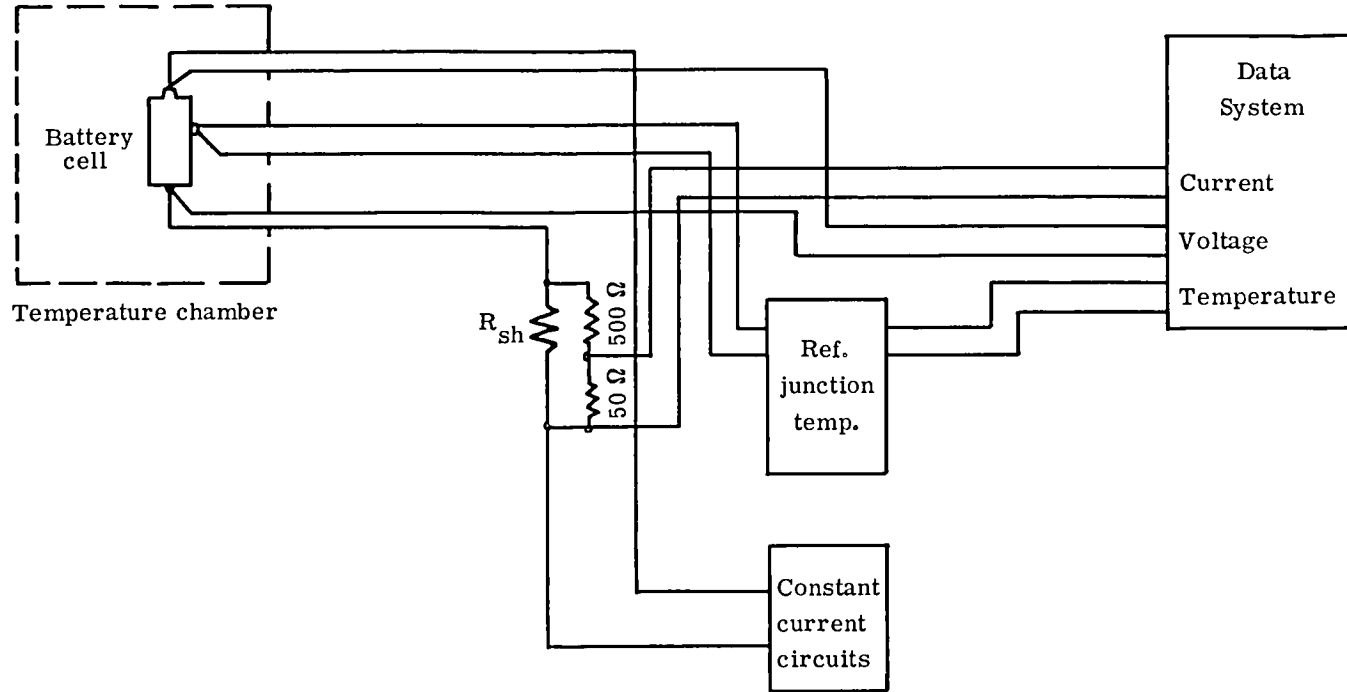

Figure 1.- Block diagram of basic test setup.

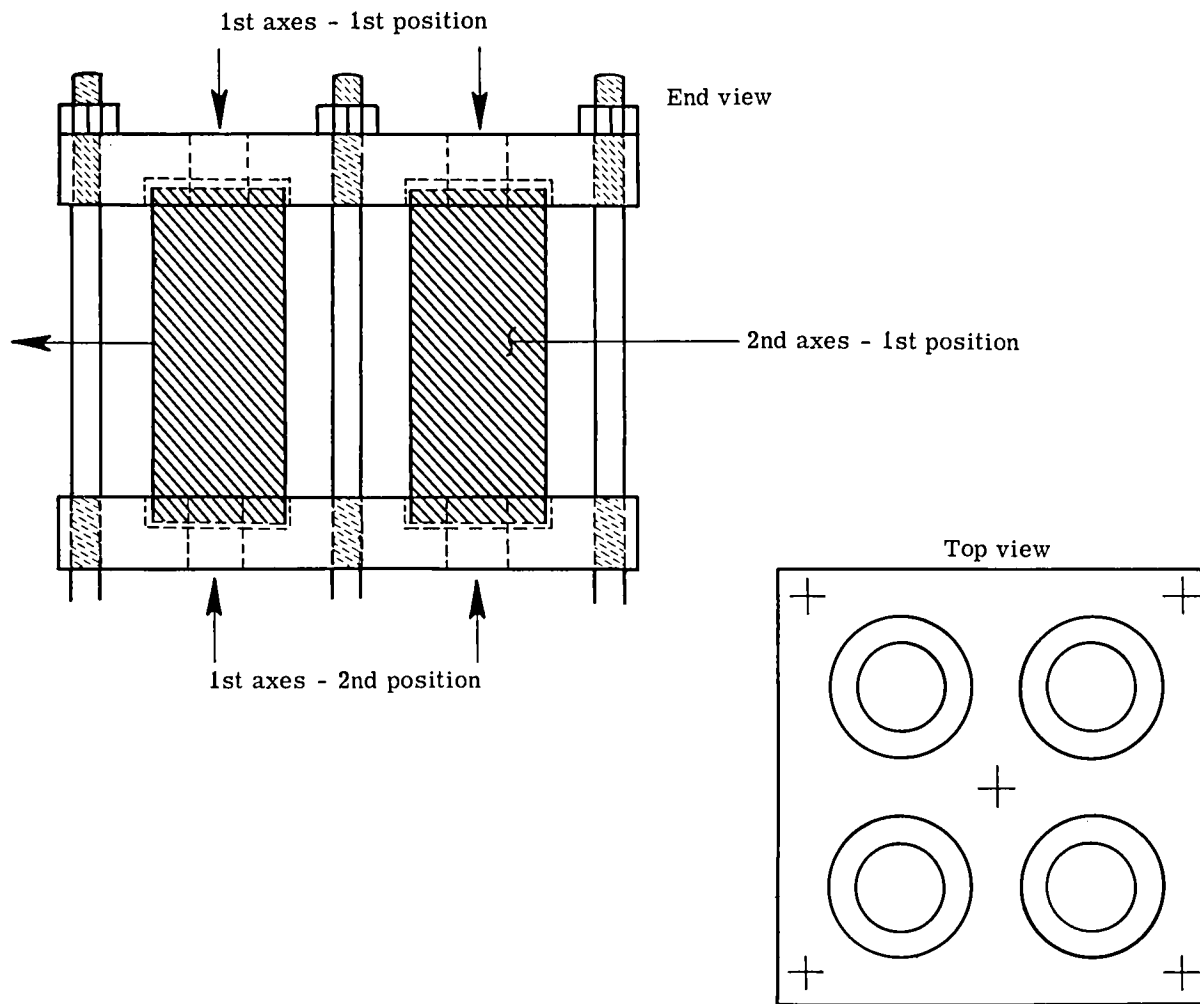

Figure 2.- Cells mounted in holders for shock tests.

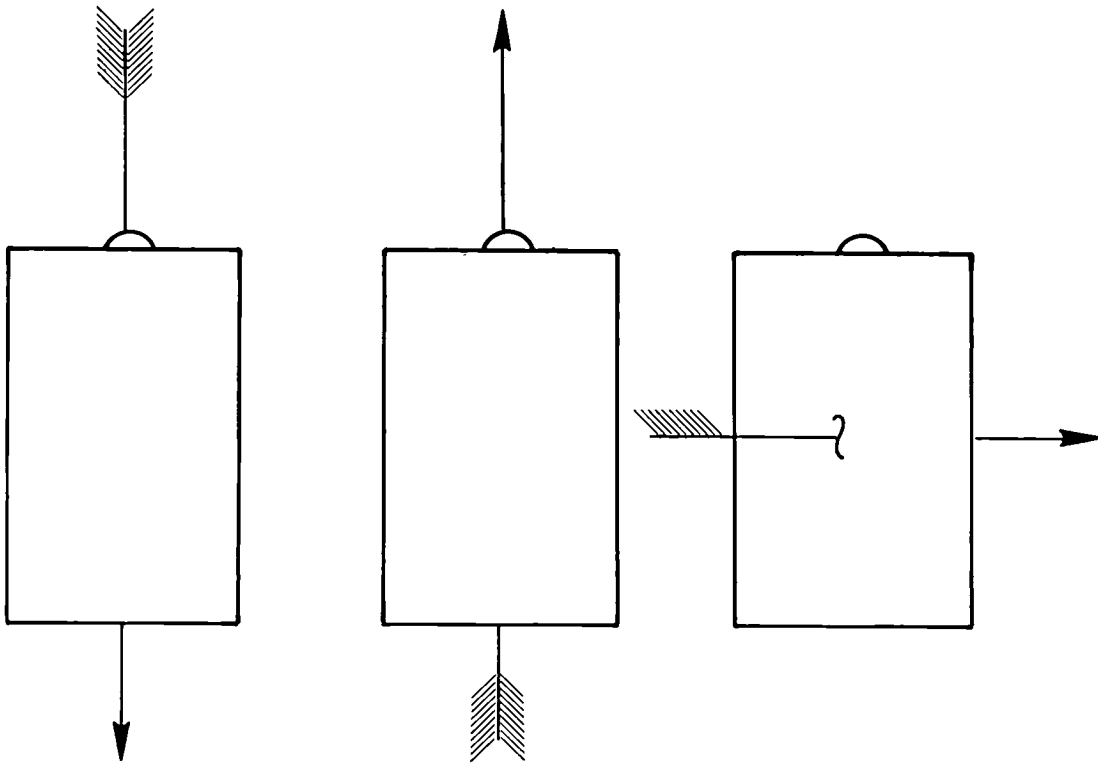
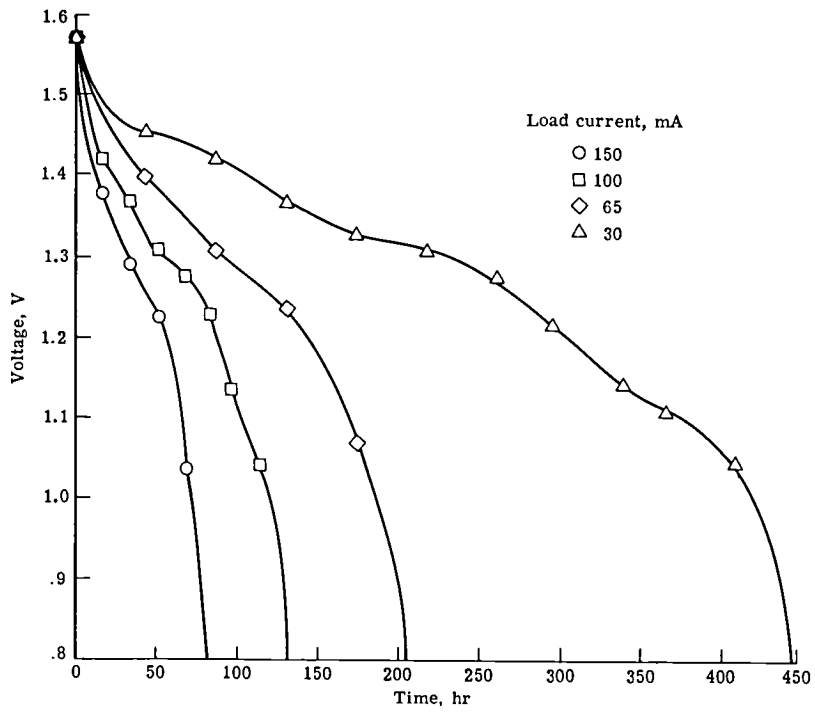
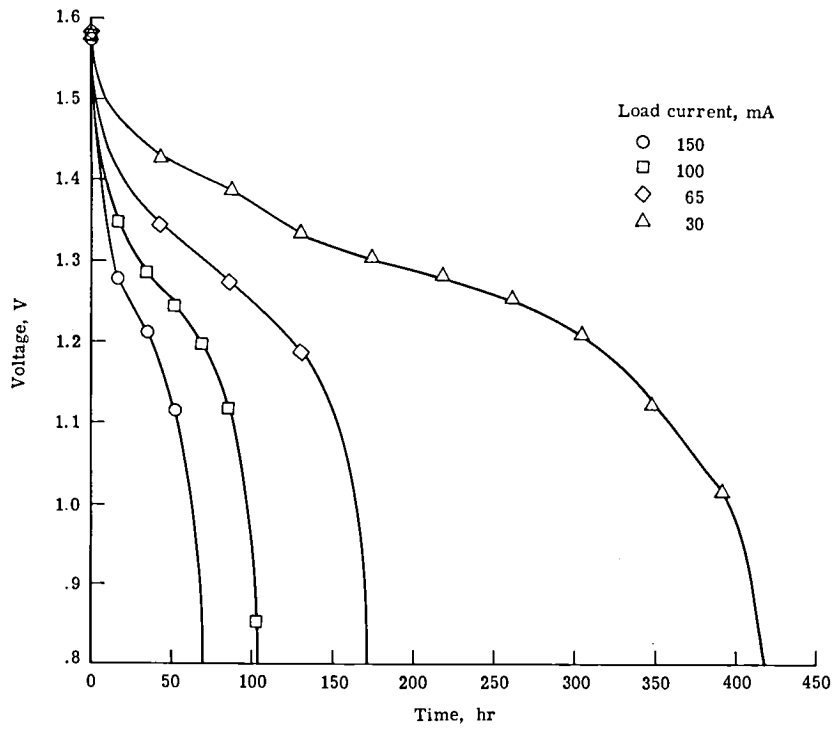

Figure 3.- Cell orientation for shock tests. Arrows show directions of applied deceleration forces.



(a) $T = 55^{\circ}\text{C}$.

Figure 4.- Discharge characteristics at four constant-current loads for cells from manufacturer A.



(b) $T = 20^\circ\text{C}$.

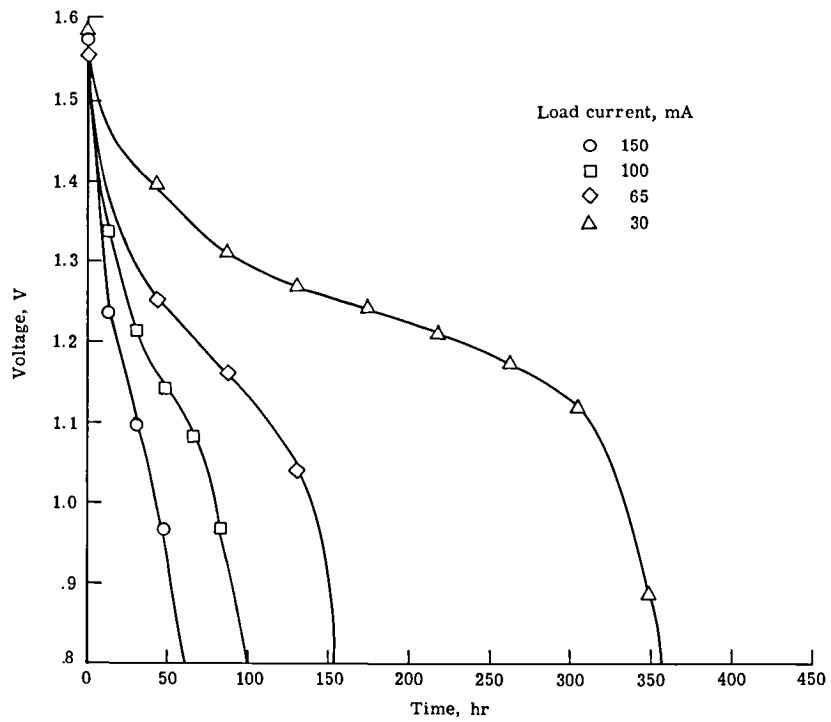

(c) $T = 0^\circ\text{C}$.

Figure 4.- Continued.

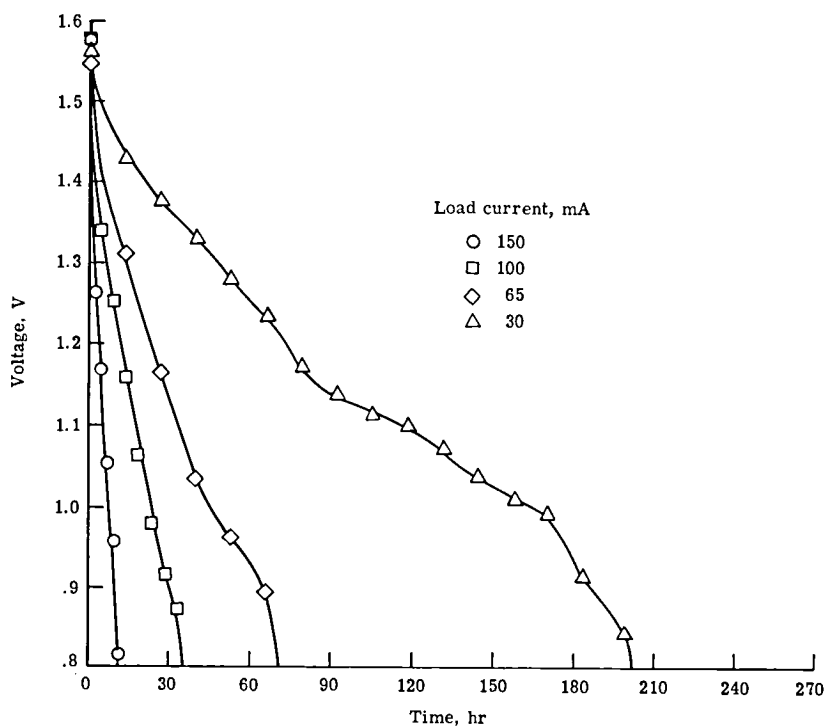

(d) $T = -20^{\circ}\text{C}.$

Figure 4.- Continued.

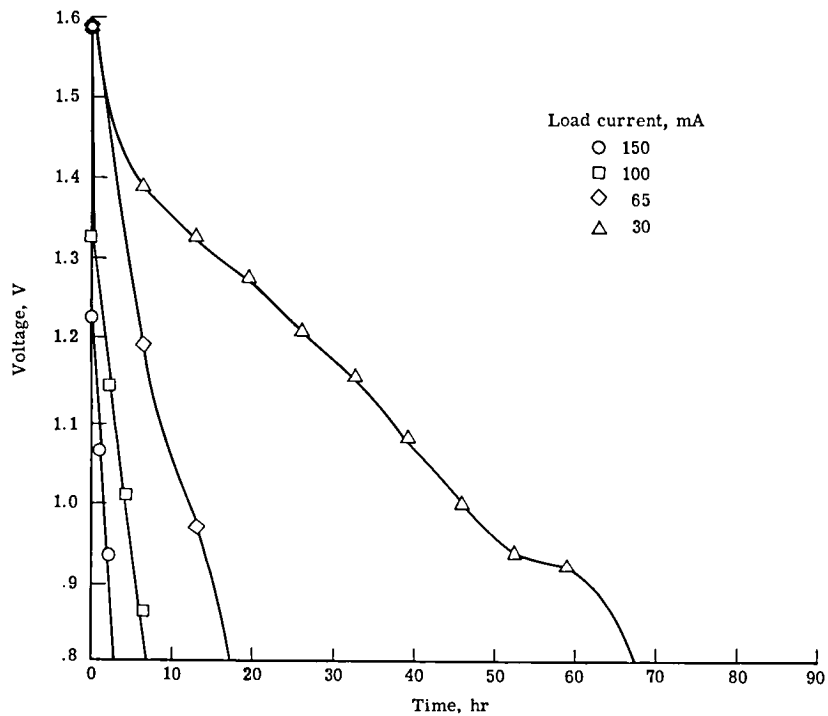

(e) $T = -40^{\circ}\text{C}.$

Figure 4.- Concluded.

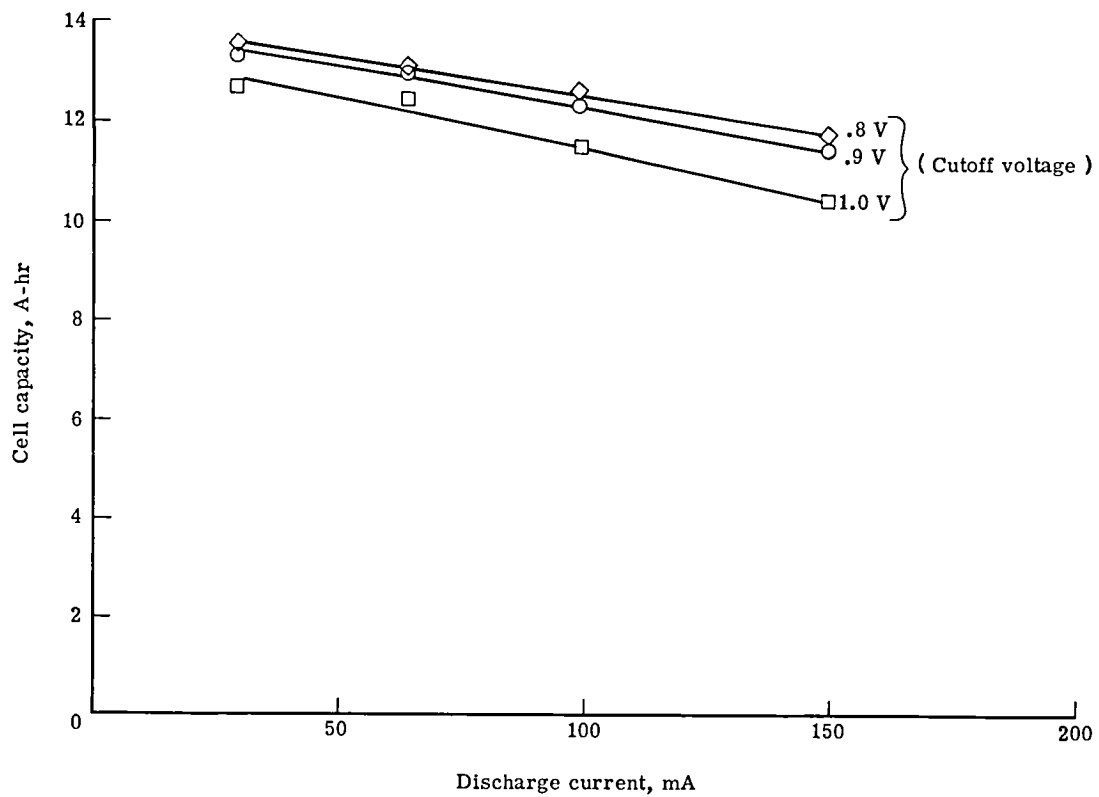

(a) $T = 55^{\circ}\text{C}$.

Figure 5.- Capacity characteristics of cells from manufacturer A.

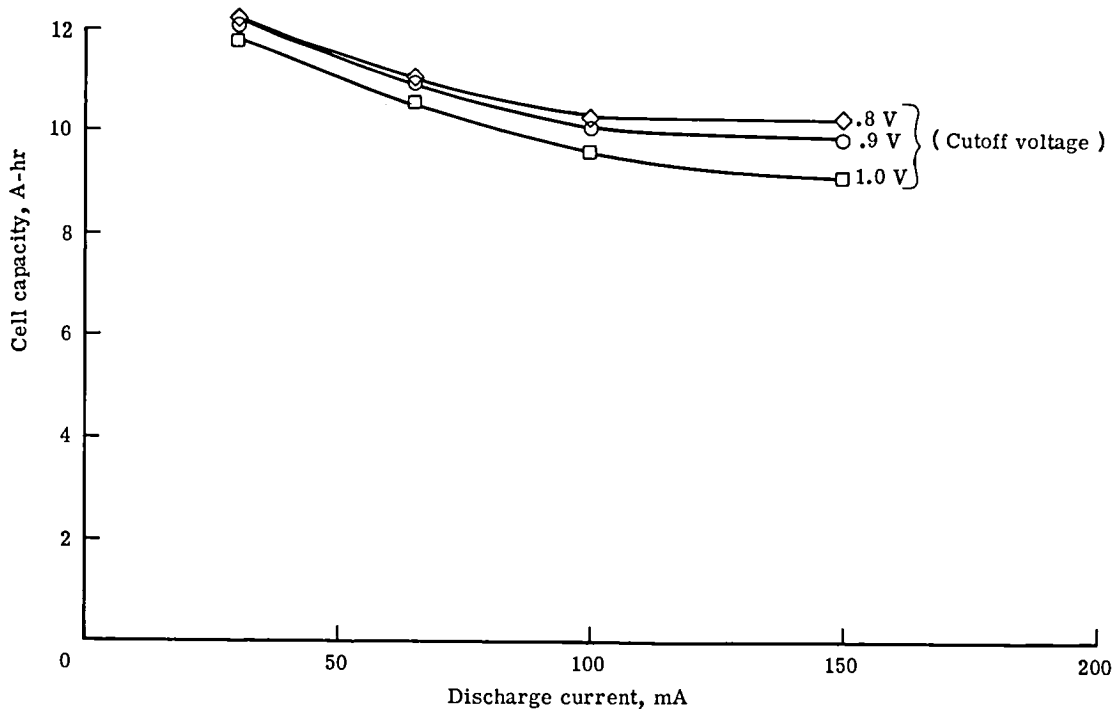

(b) $T = 20^\circ\text{C}$.

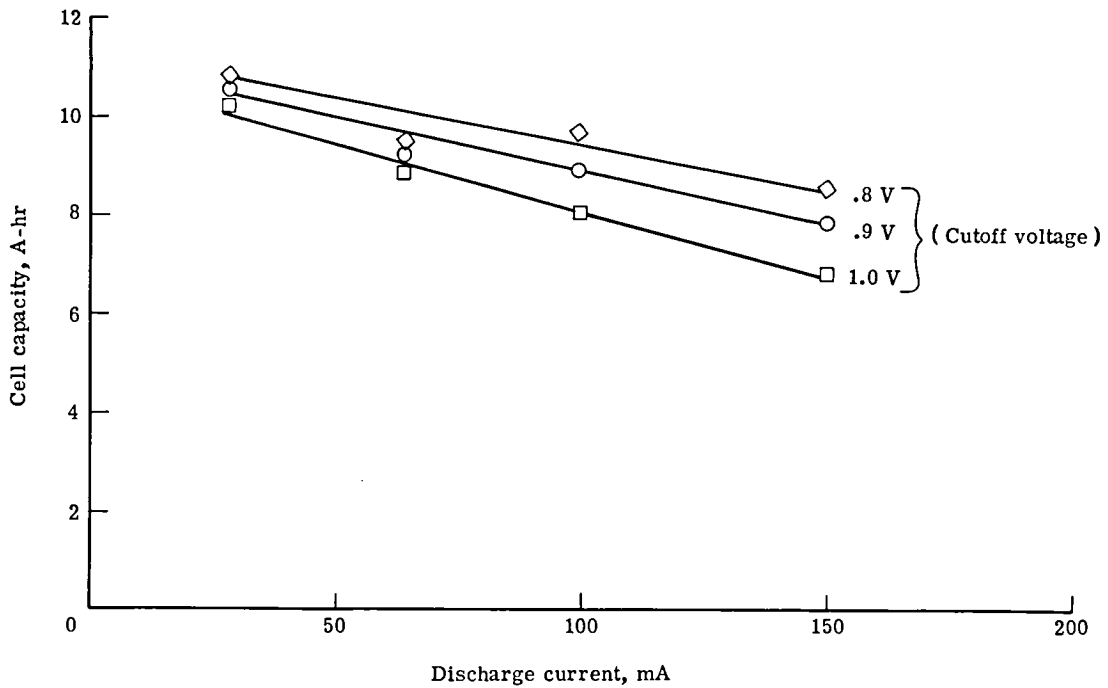

(c) $T = 0^\circ\text{C}$.

Figure 5.- Continued.

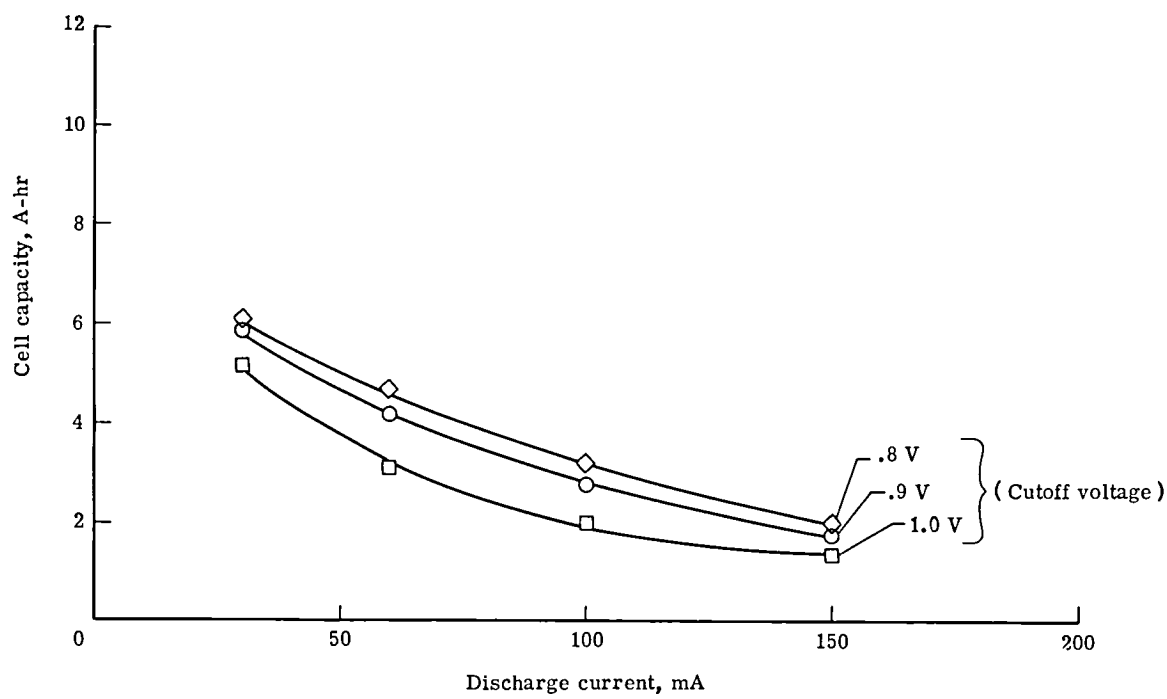

(d) $T = -20^{\circ}\text{C}$.

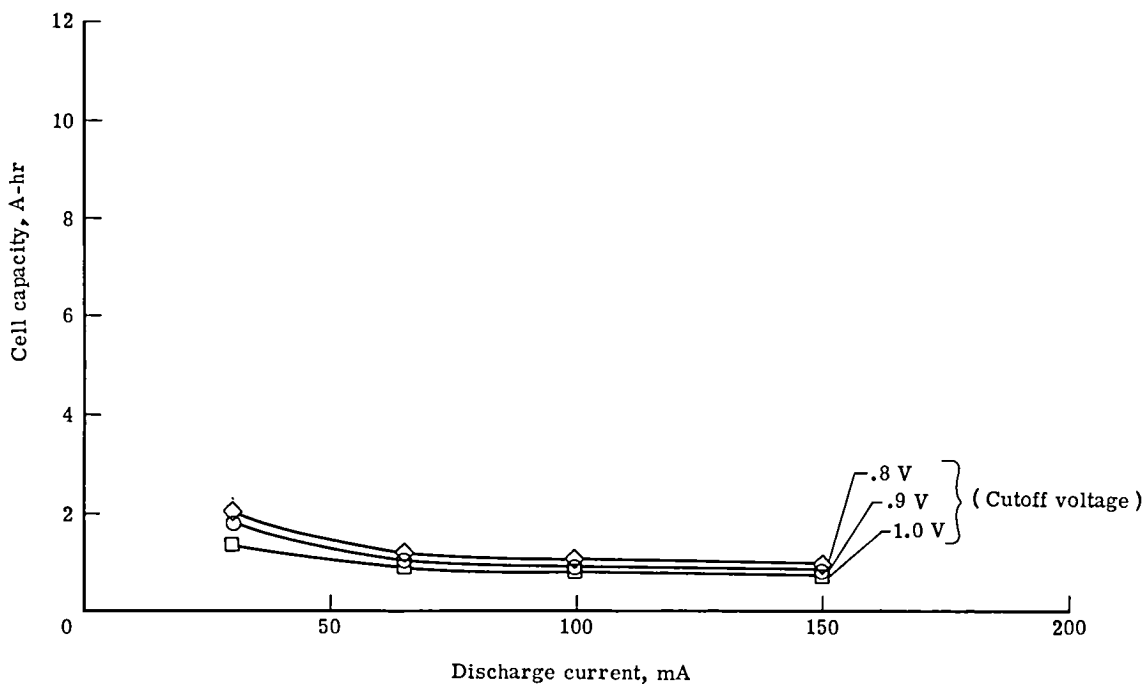

(e) $T = -40^{\circ}\text{C}$.

Figure 5.- Concluded.

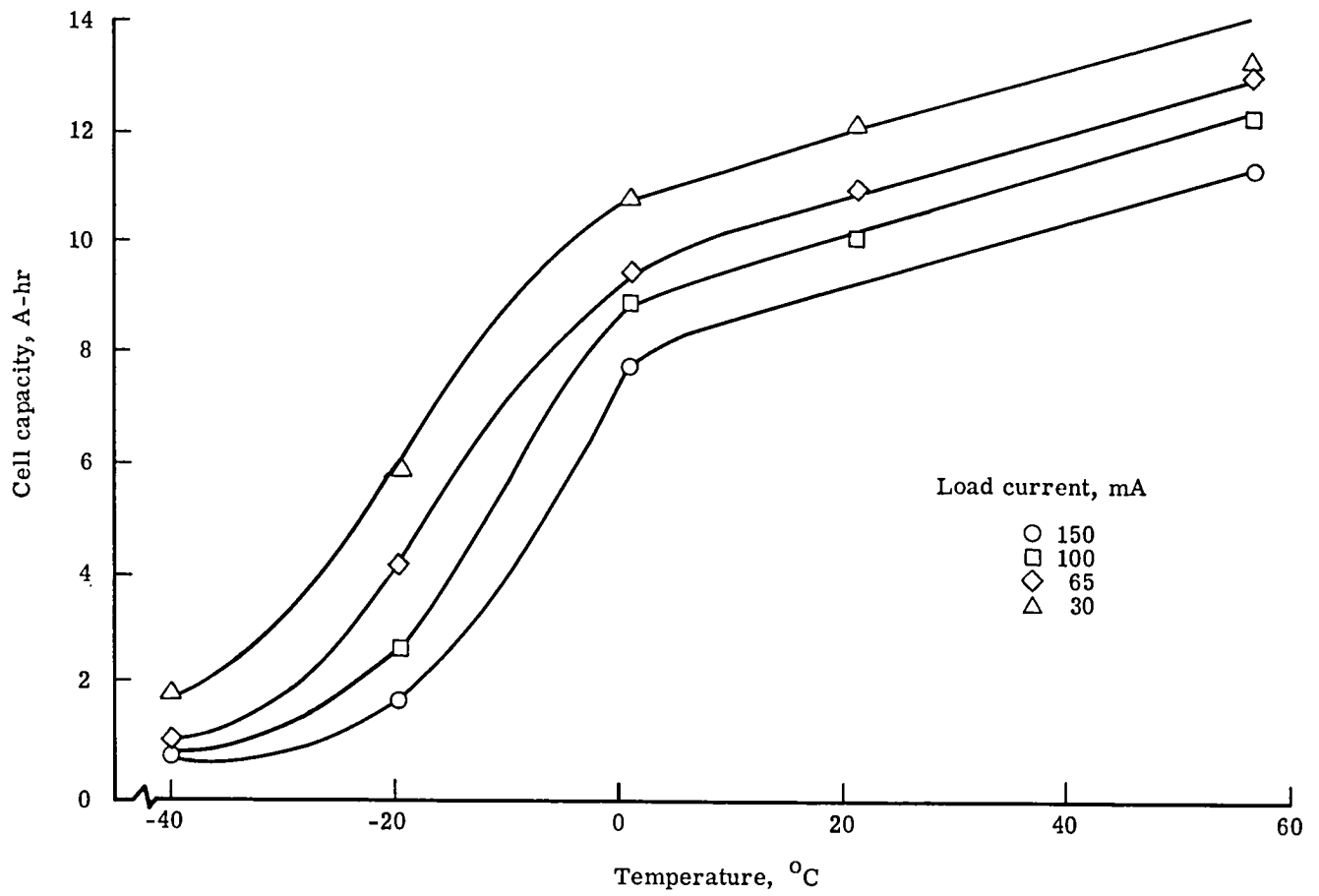
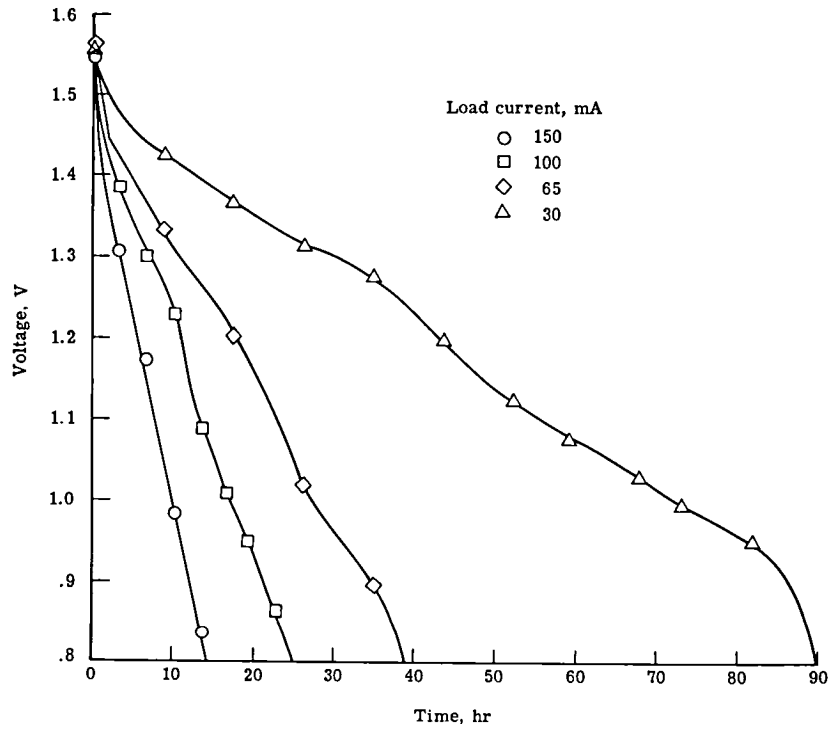
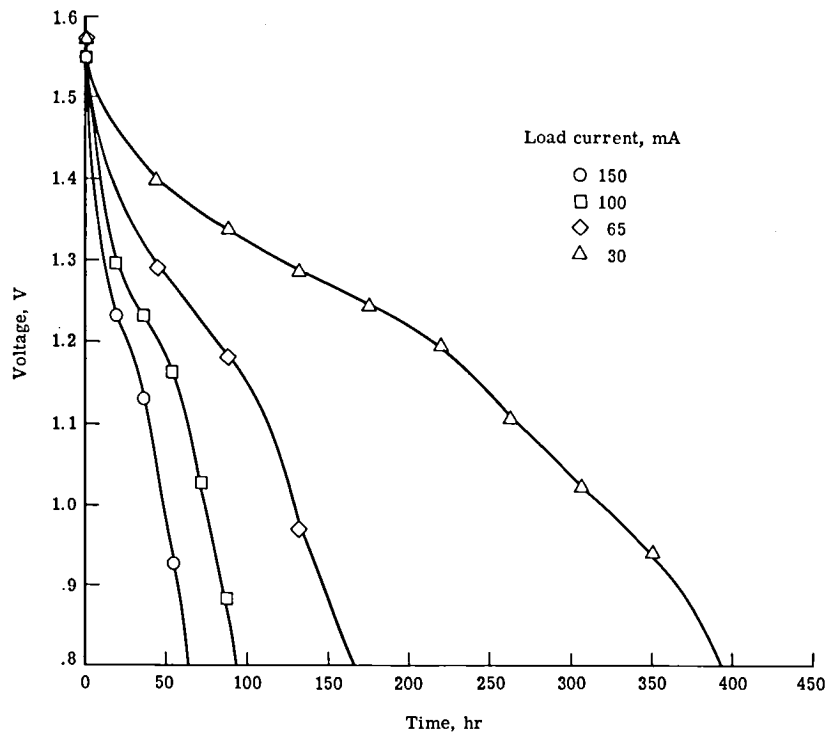

Figure 6.- Effect of temperature on capacity (0.9-V cutoff voltage) for cells from manufacturer A.



(a) T = 55°C.

Figure 7.- Discharge characteristics at four constant-current loads for cells from manufacturer B.



(b) $T = 20^\circ\text{C}$.

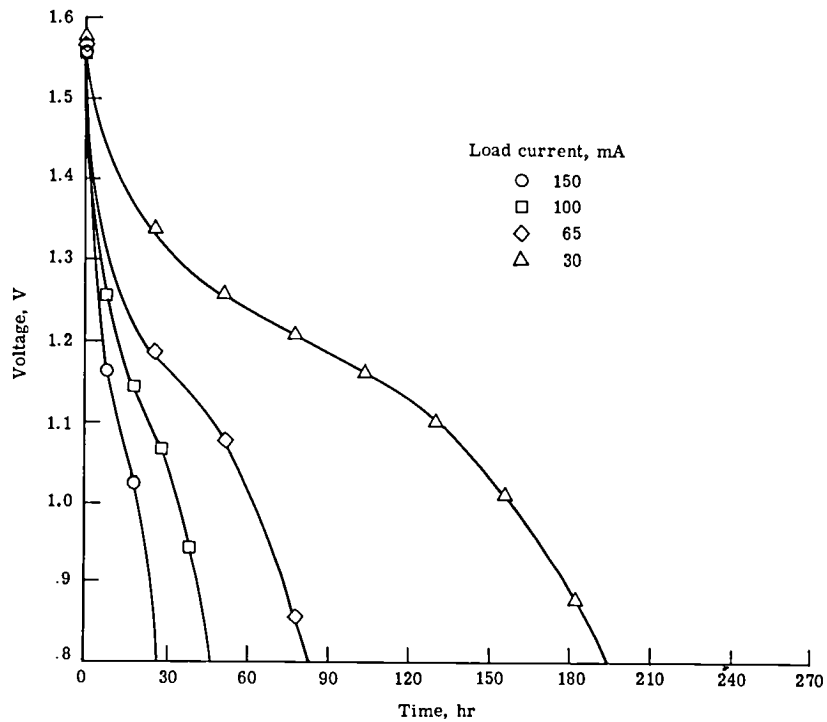

(c) $T = 0^\circ\text{C}$.

Figure 7.- Continued.

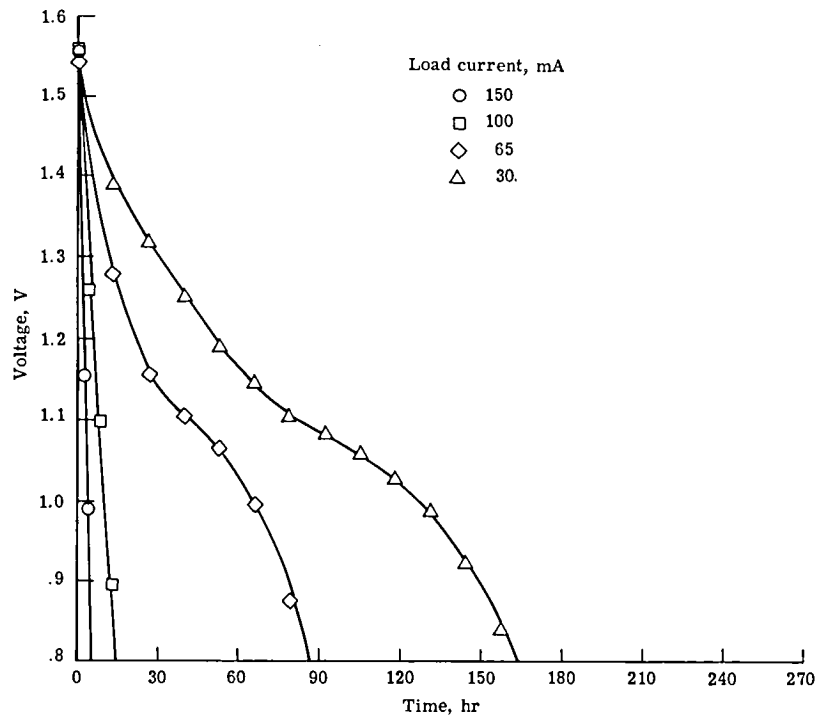

(d) $T = -20^{\circ}\text{C}$.

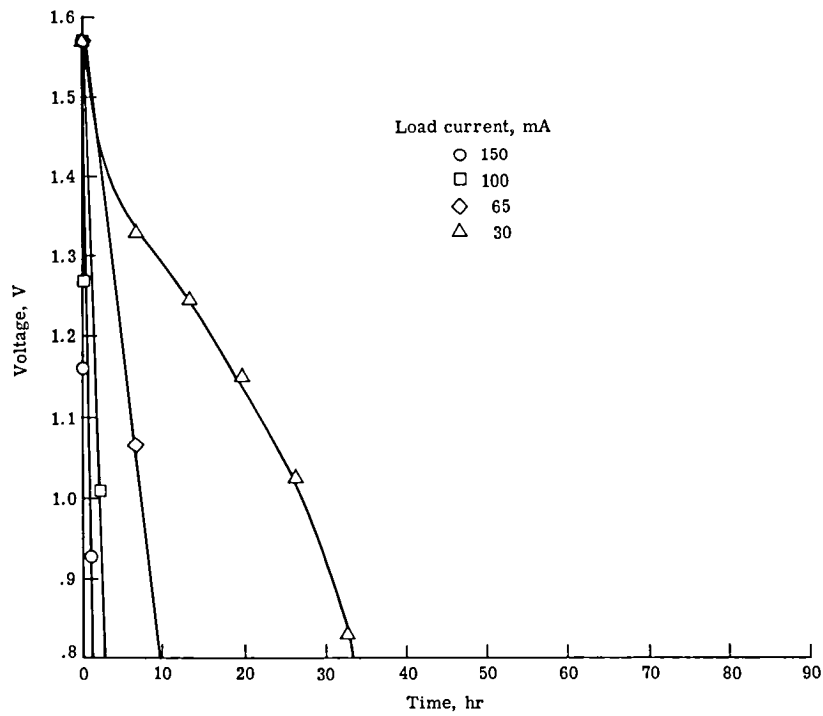

(e) $T = -40^{\circ}\text{C}$.

Figure 7.- Concluded.

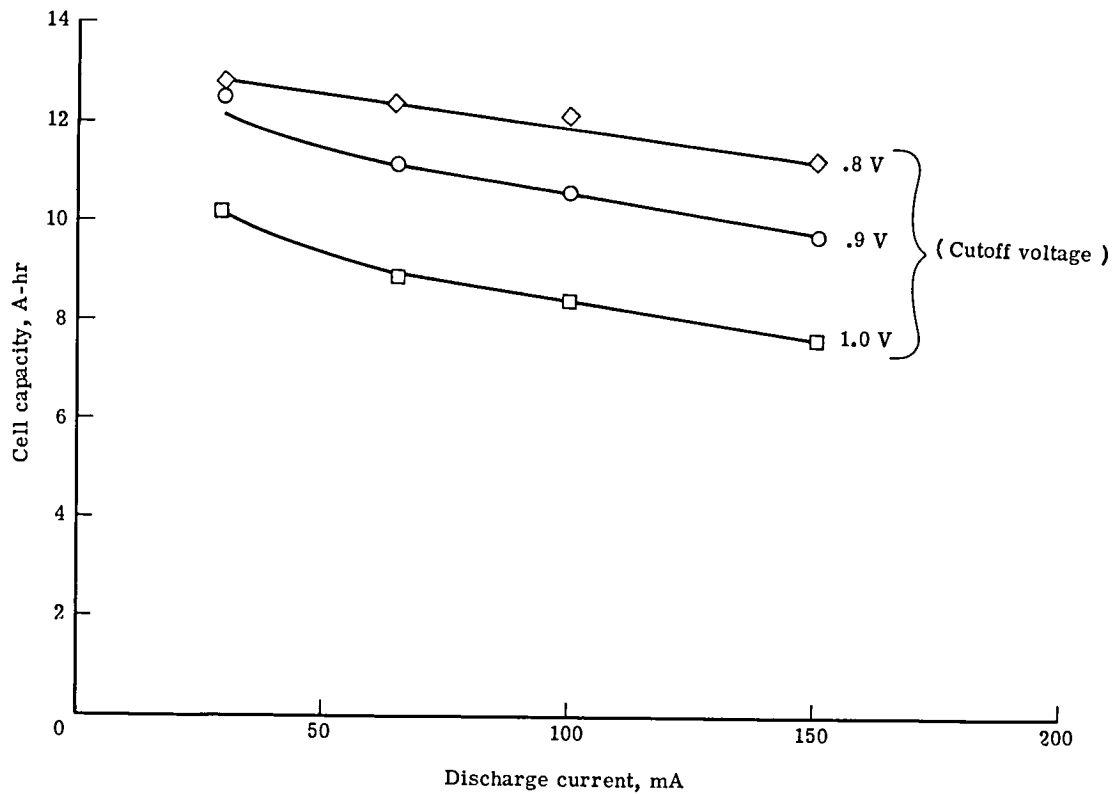

(a) $T = 55^{\circ}\text{C}$.

Figure 8.- Capacity characteristics of cells from manufacturer B.

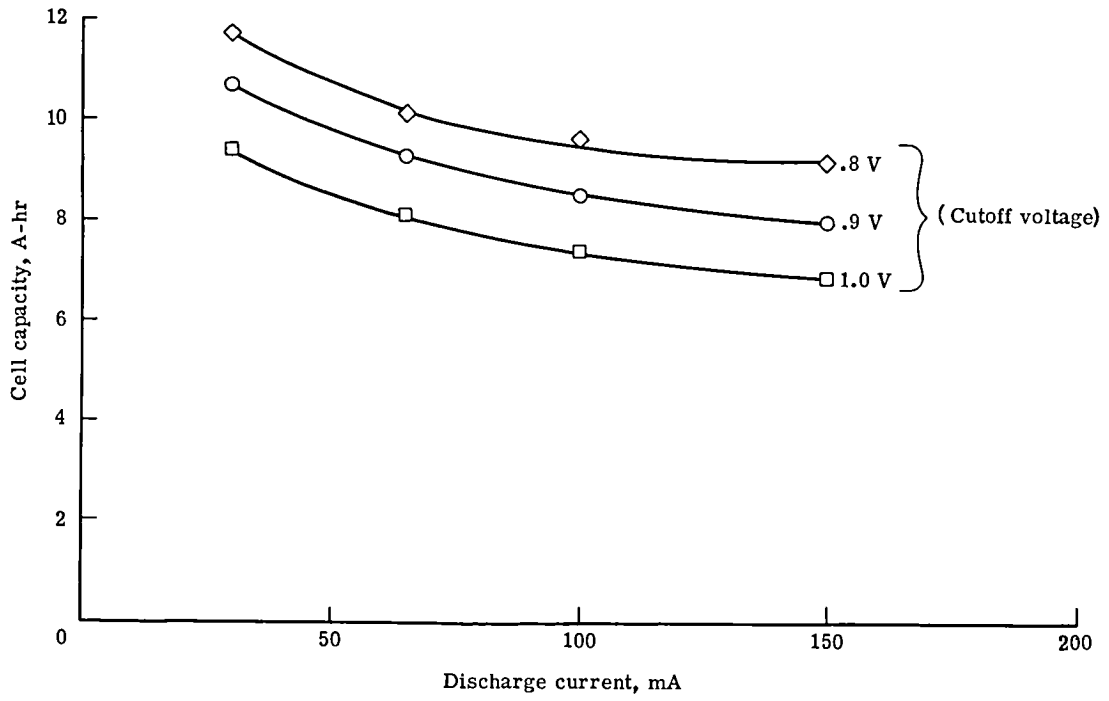

(b) $T = 20^{\circ}\text{C}.$

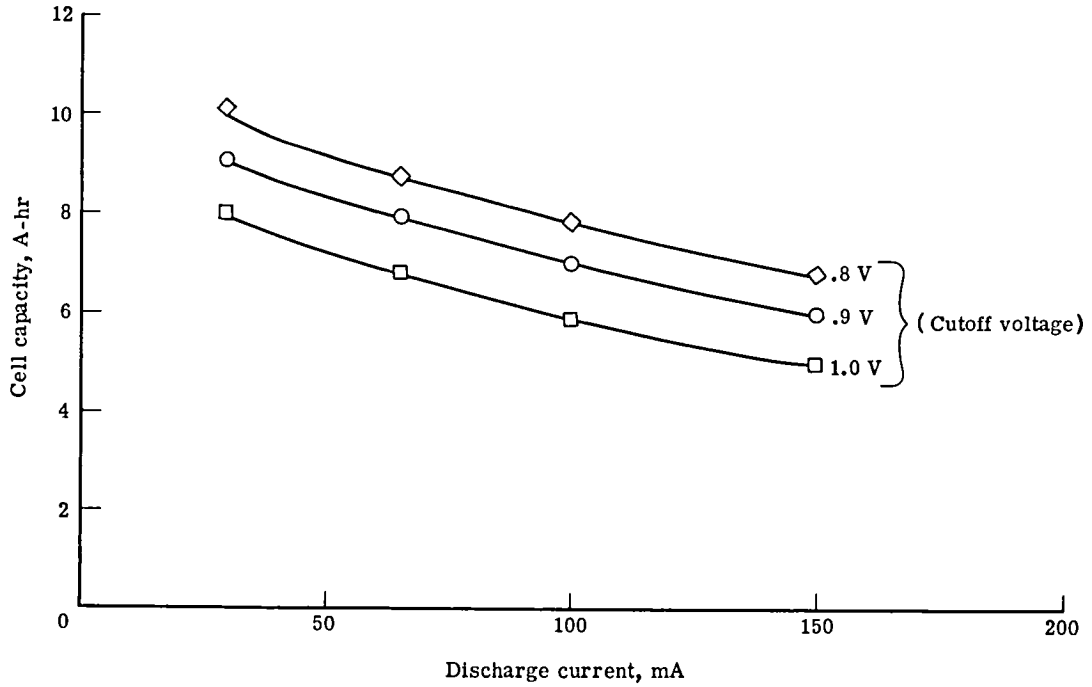

(c) $T = 0^{\circ}\text{C}.$

Figure 8.- Continued.

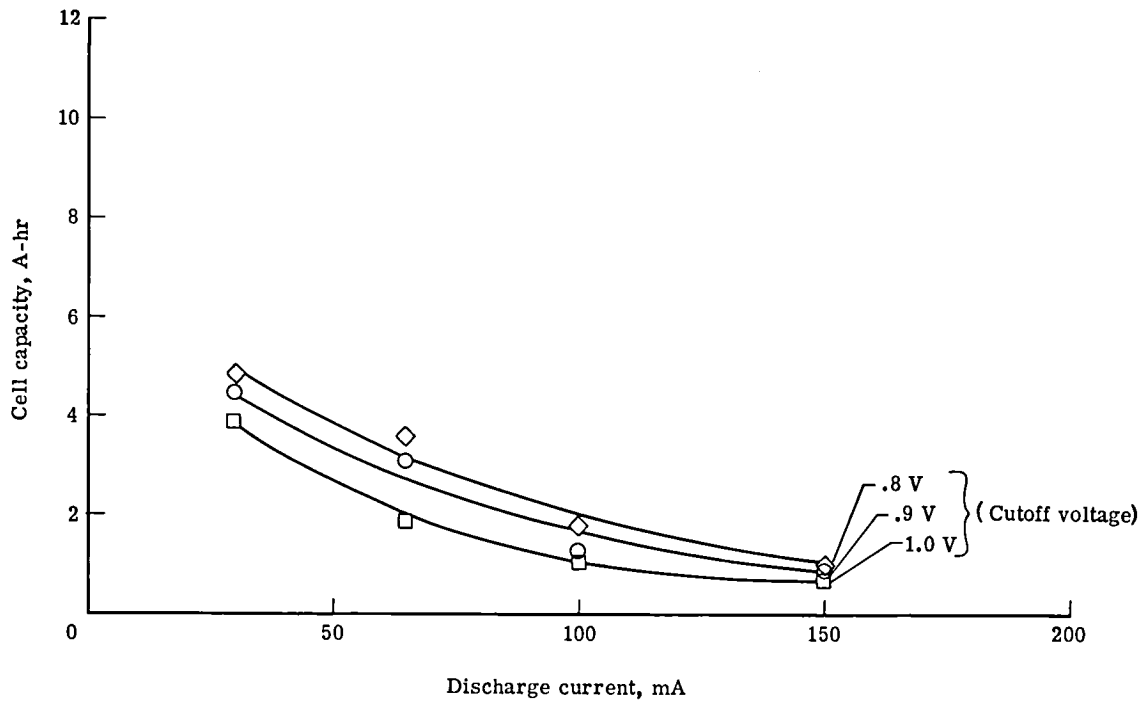

(d) $T = -20^{\circ}\text{C}$.

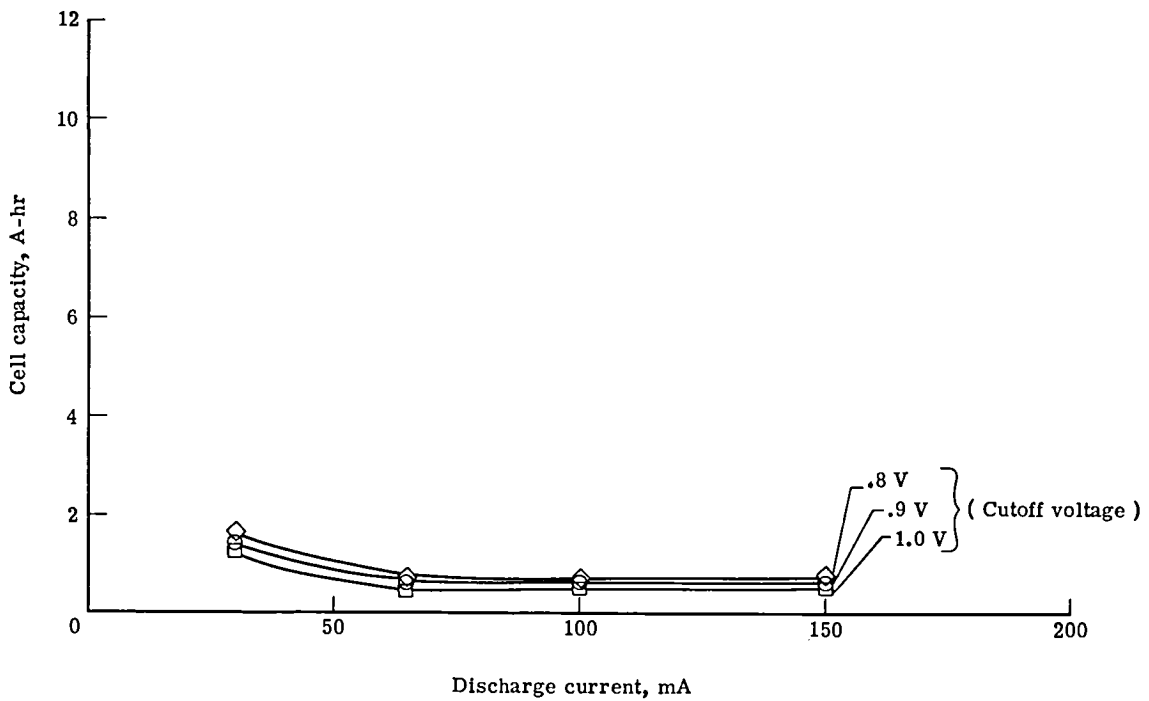

(e) $T = -40^{\circ}\text{C}$.

Figure 8.- Concluded.

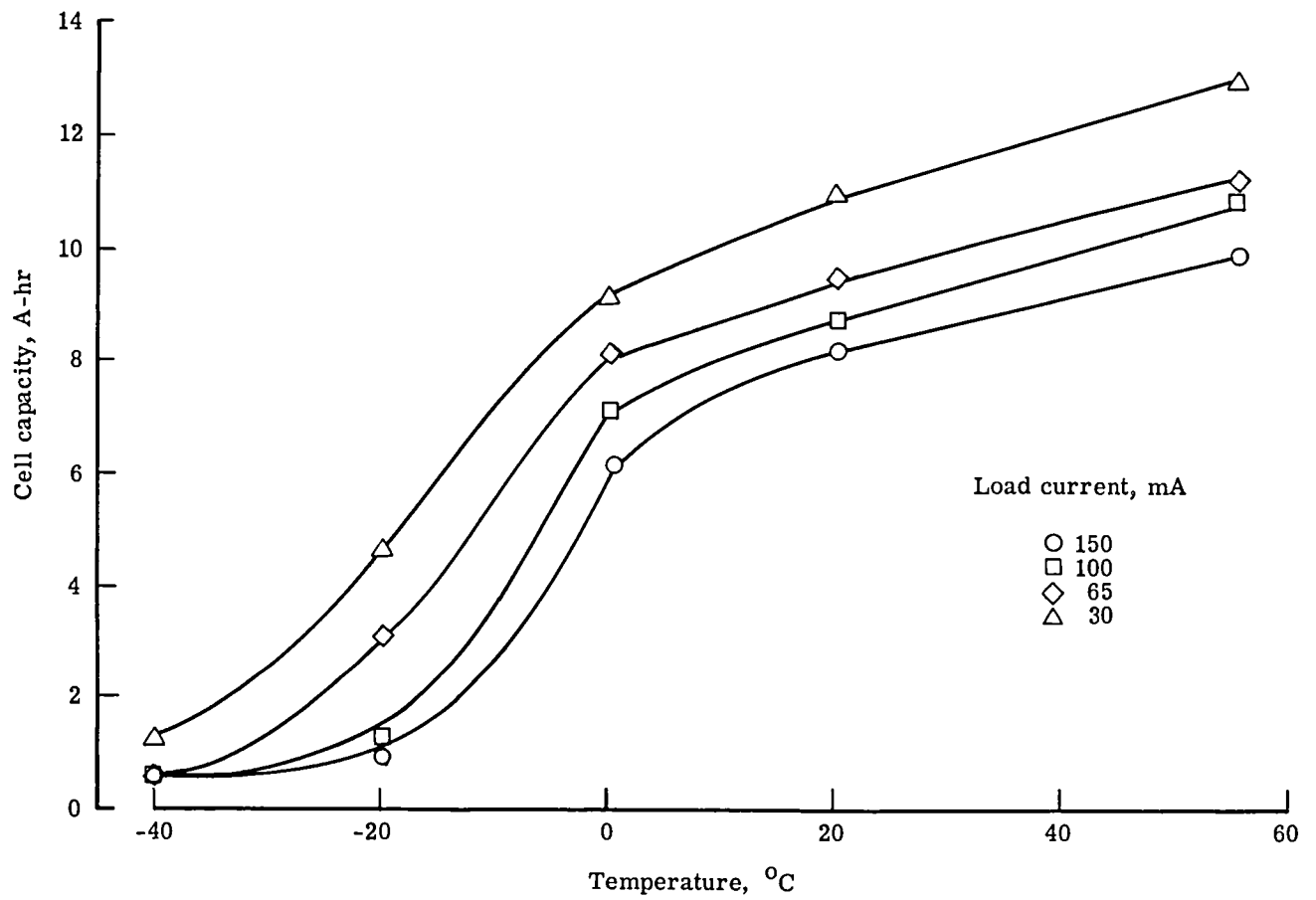
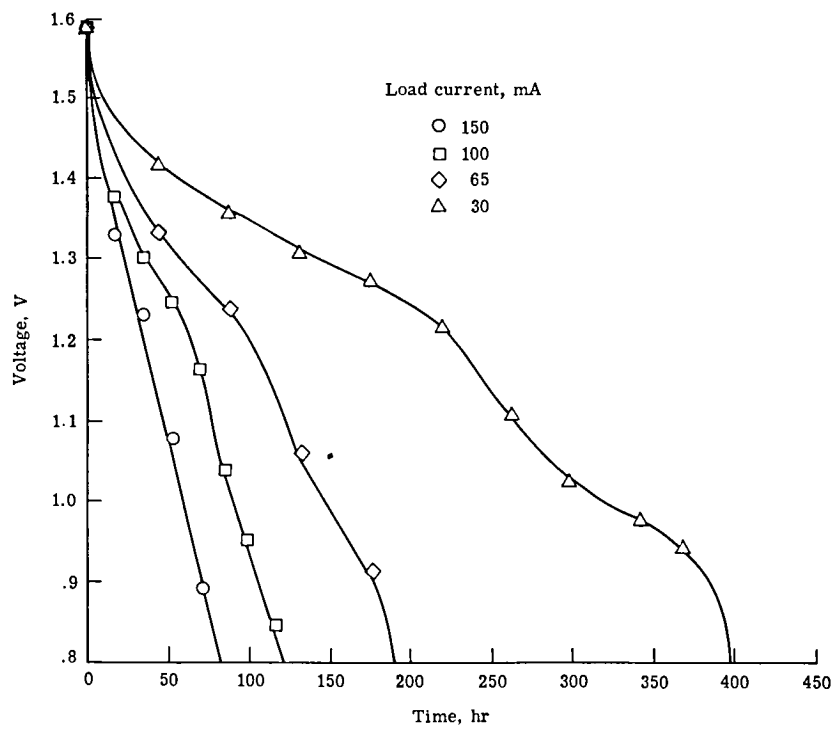
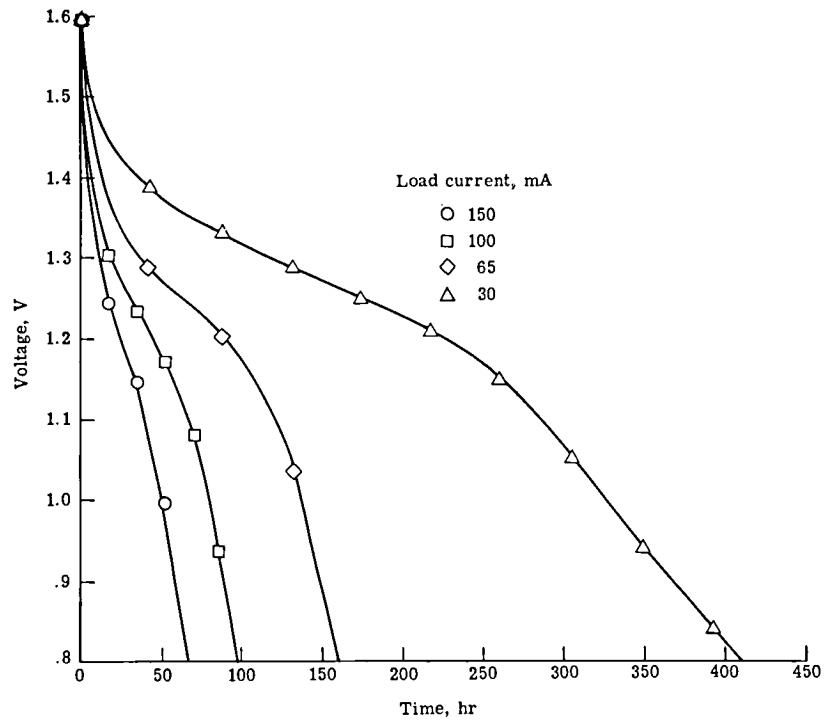

Figure 9.- Effect of temperature on capacity (0.9-V cutoff voltage) for cells from manufacturer B.



(a) $T = 55^{\circ}\text{C}$.

Figure 10.- Discharge characteristics at four constant-current loads for cells from manufacturer C.



(b) $T = 20^{\circ}\text{C}$.

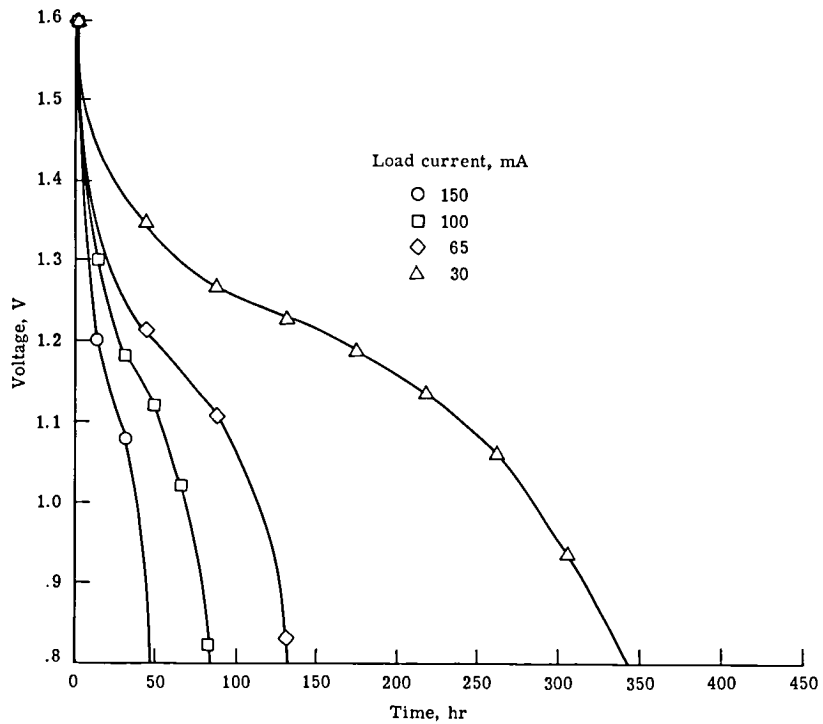

(c) $T = 0^{\circ}\text{C}$.

Figure 10.- Continued.

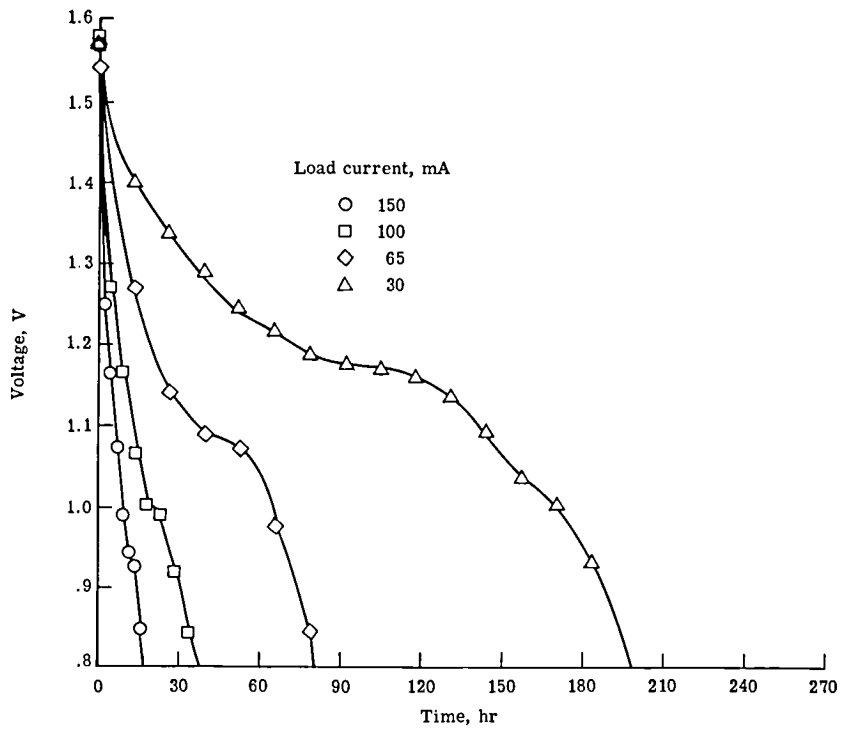

(d) $T = -20^{\circ}\text{C}$.

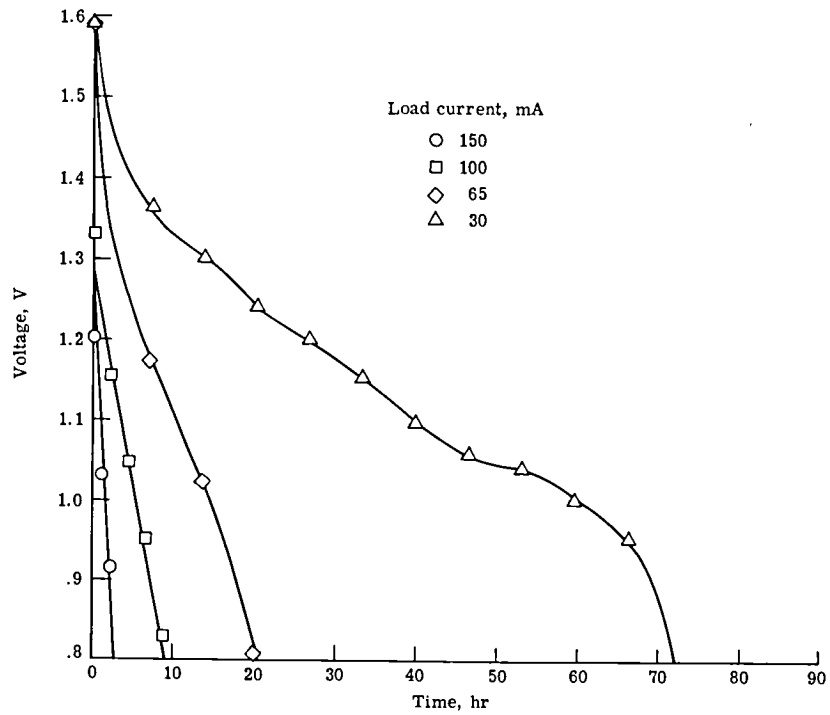

(e) $T = -40^{\circ}\text{C}$.

Figure 10.- Concluded.

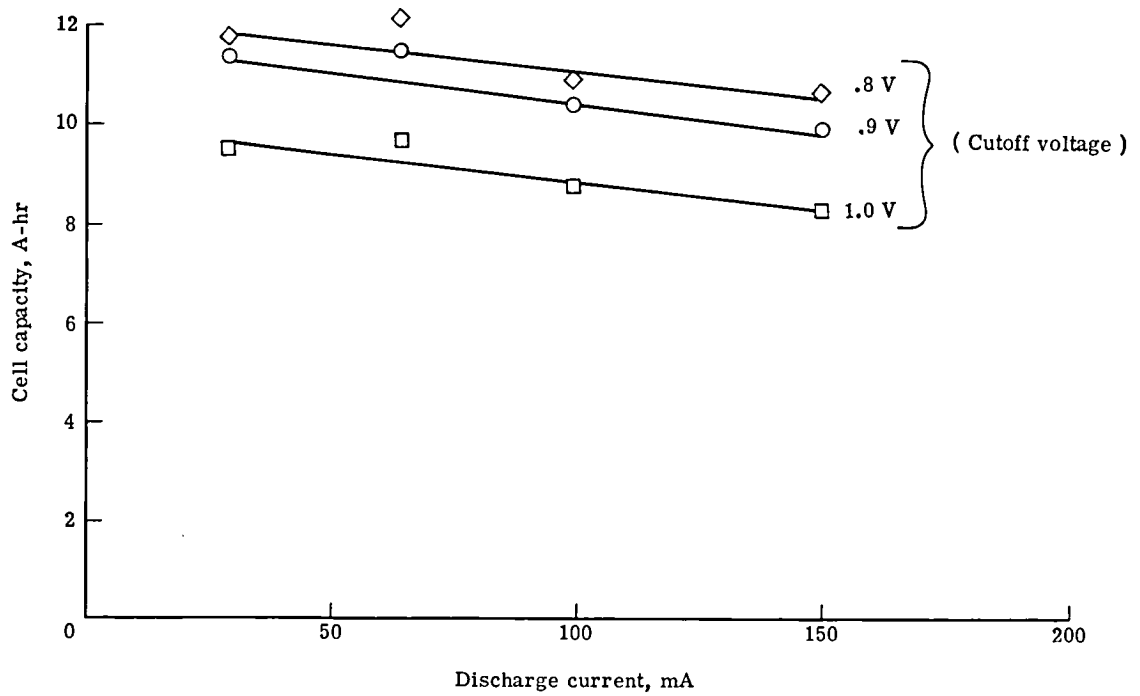

(a) $T = 55^{\circ}\text{C}$.

Figure 11.- Capacity characteristics of cells from manufacturer C.

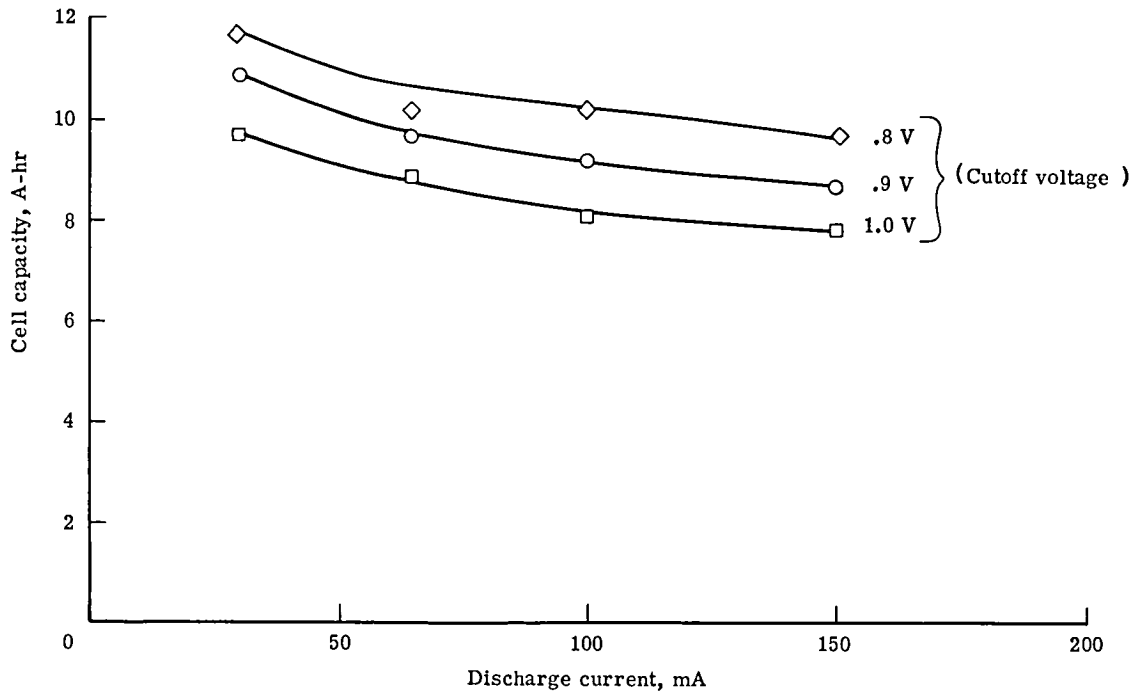

(b) $T = 20^{\circ}\text{C}.$

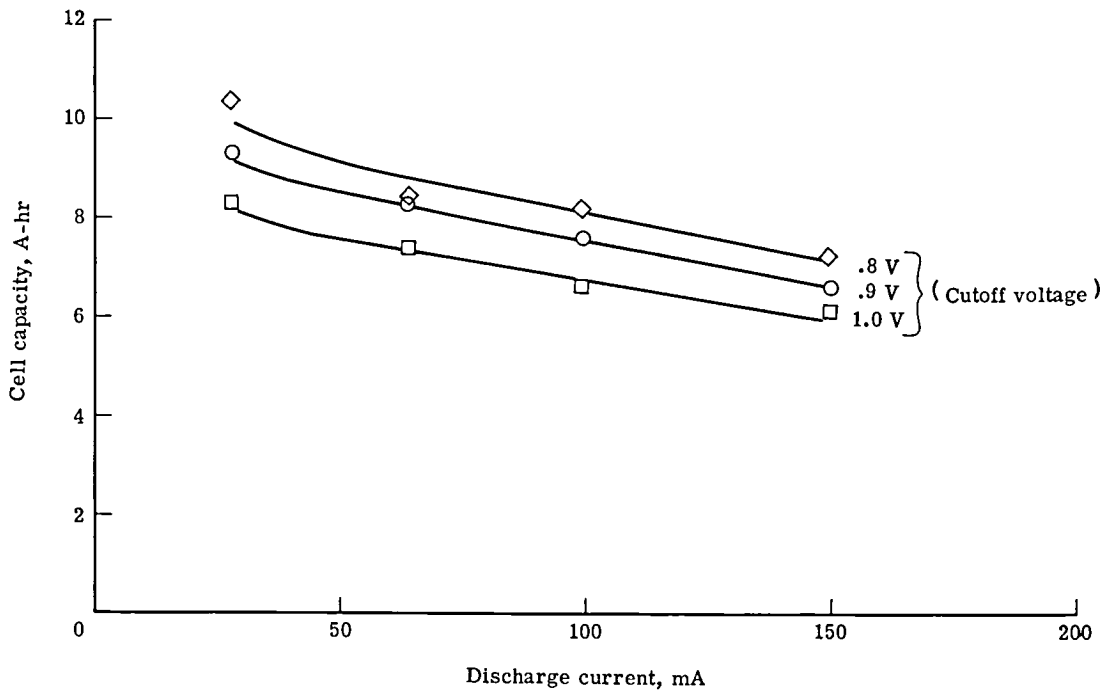

(c) $T = 0^{\circ}\text{C}.$

Figure 11.- Continued.

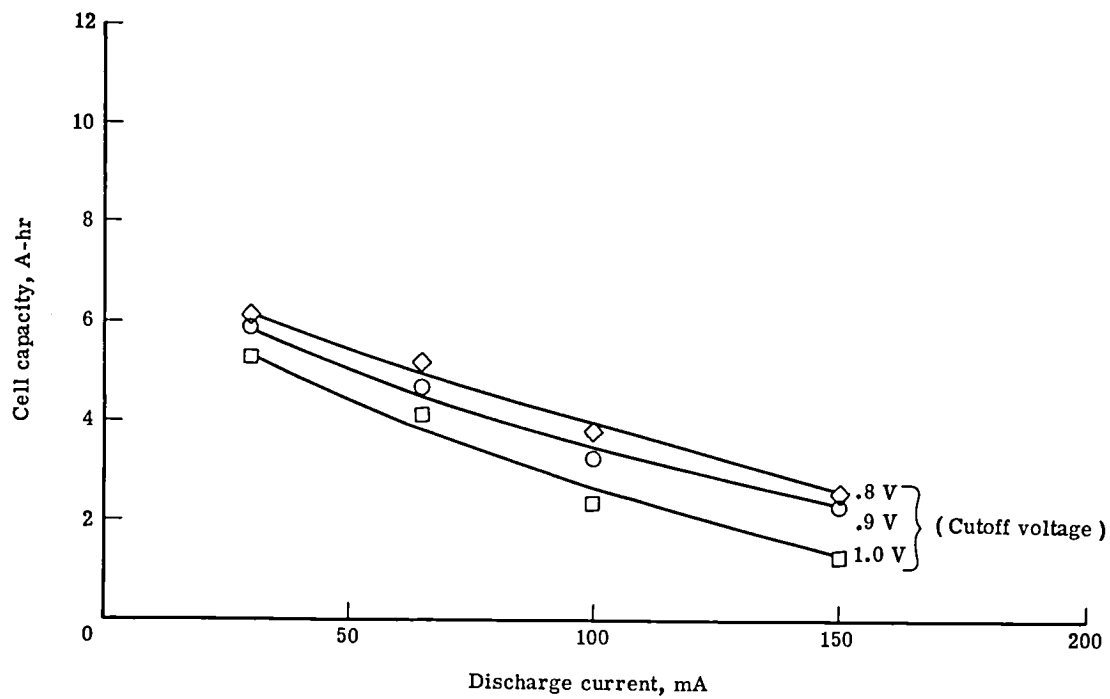

(d) $T = -20^{\circ}\text{C}$.

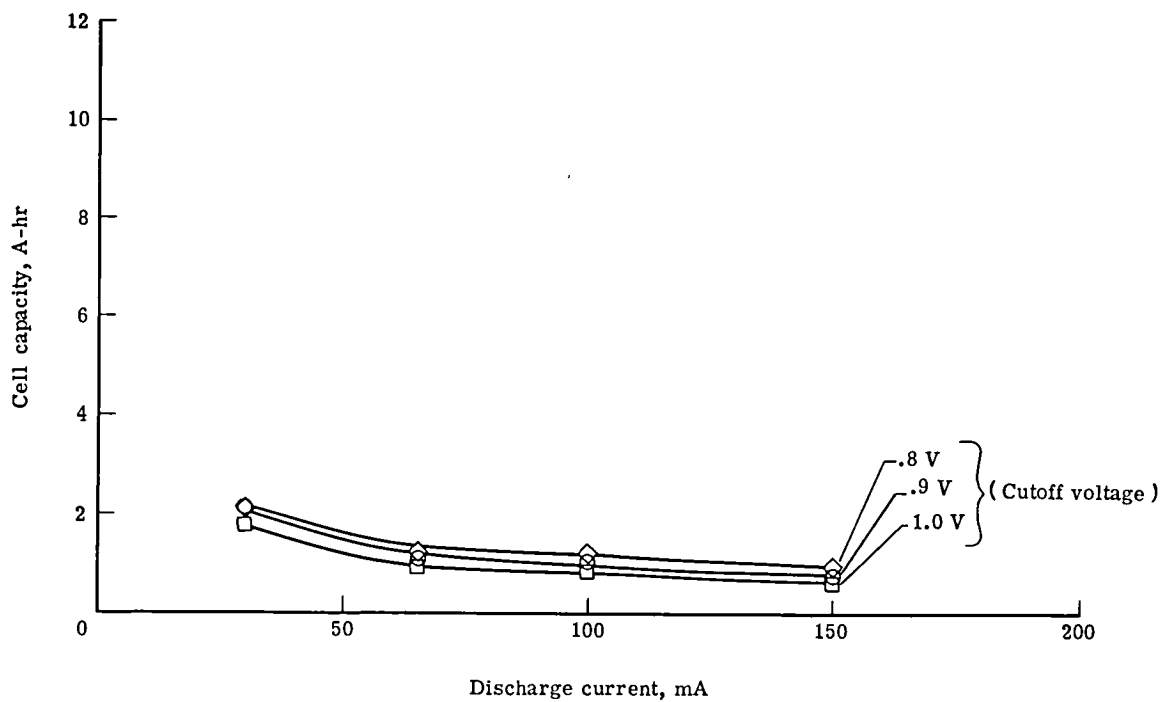

(e) $T = -40^{\circ}\text{C}$.

Figure 11.- Concluded.

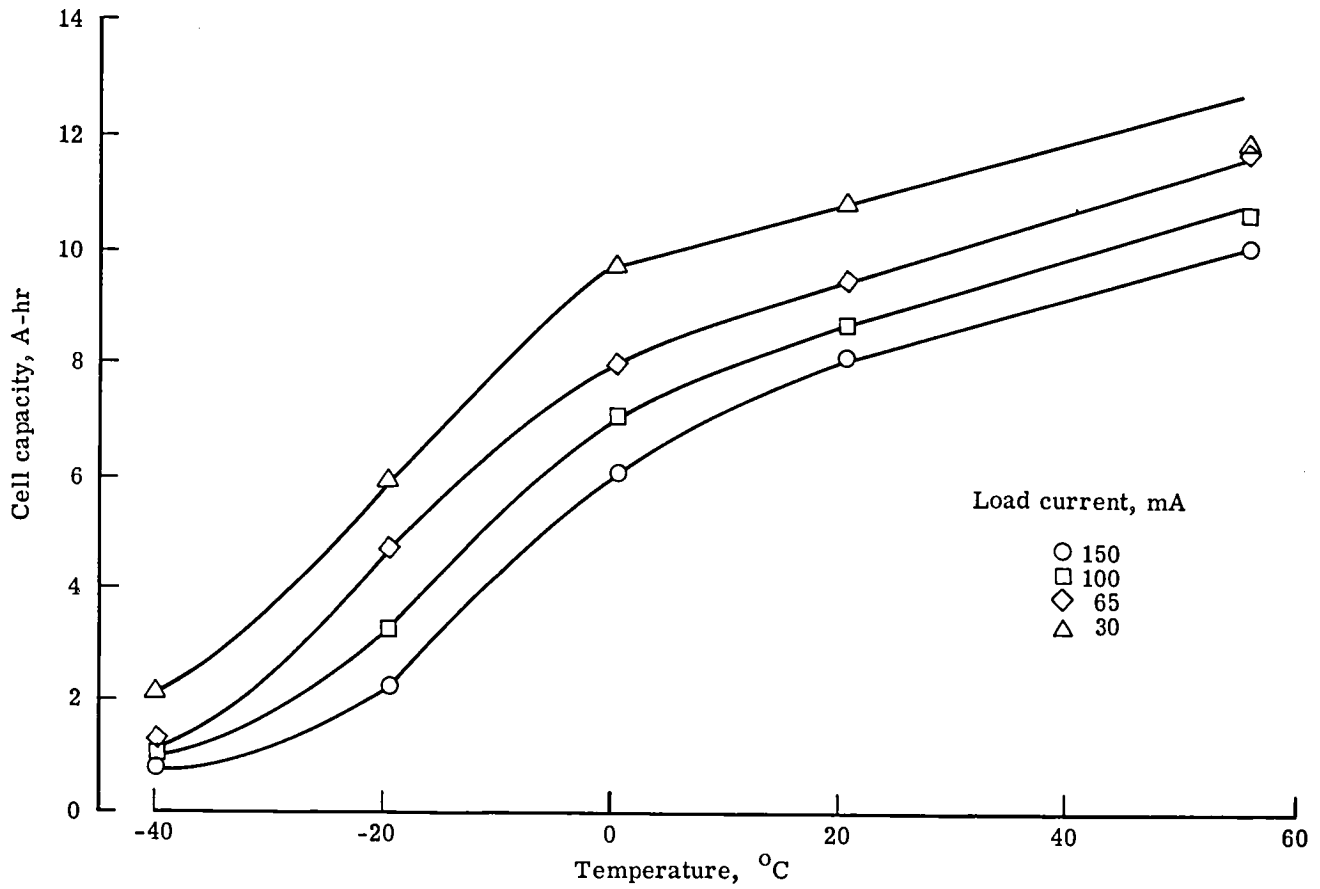
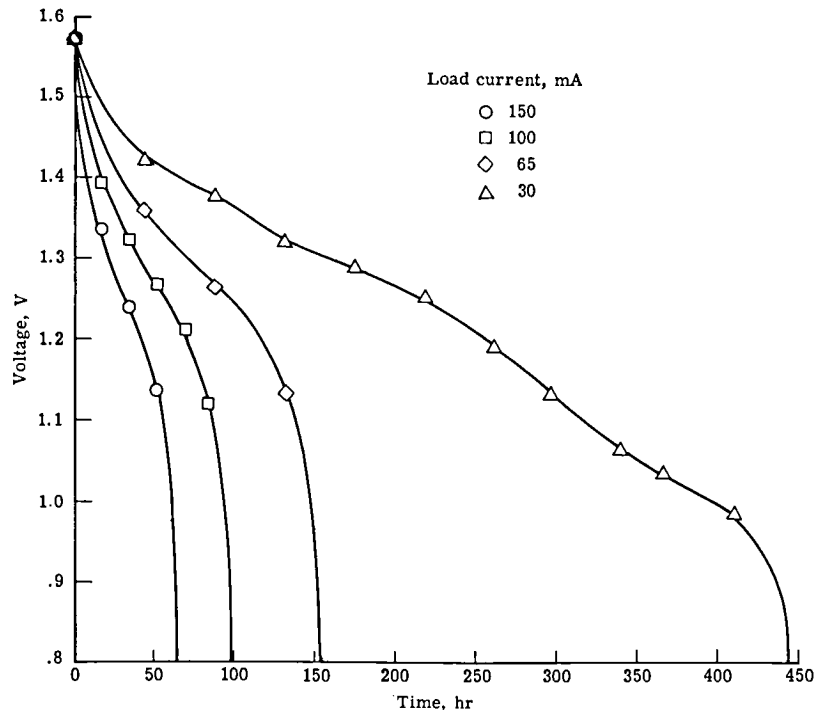
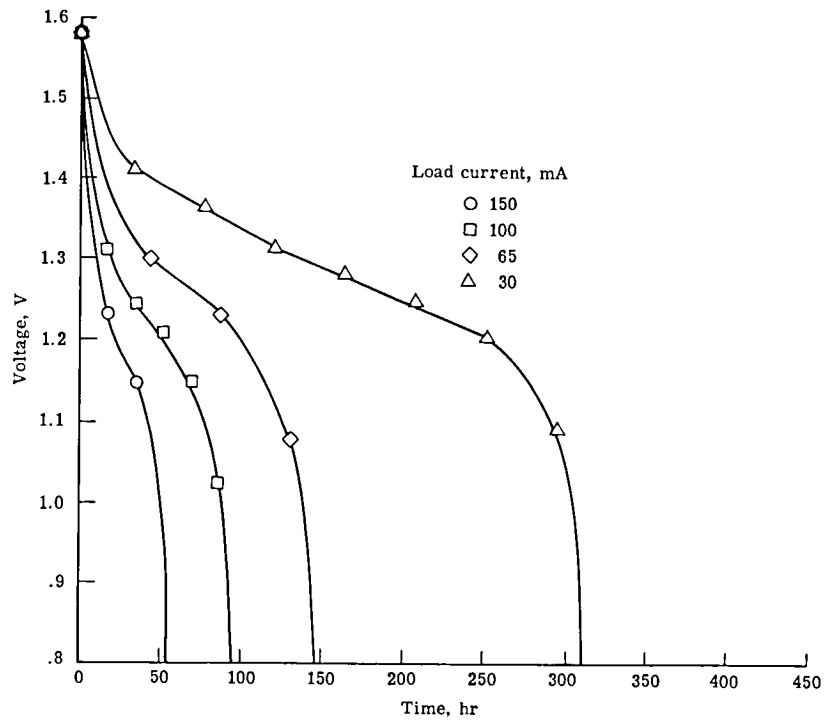

Figure 12.- Effect of temperature on capacity (0.9-V cutoff voltage) for cells from manufacturer C.



(a) $T = 55^{\circ}\text{C}$.

Figure 13.- Discharge characteristics at four constant-current loads for cells from manufacturer D.



(b) $T = 20^\circ\text{C}$.

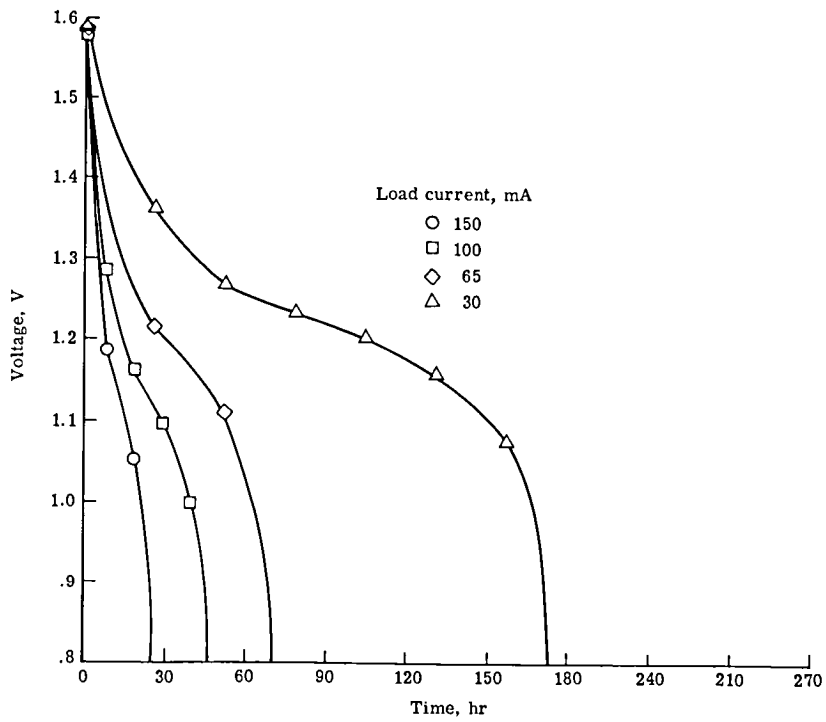

(c) $T = 0^\circ\text{C}$.

Figure 13.- Continued.

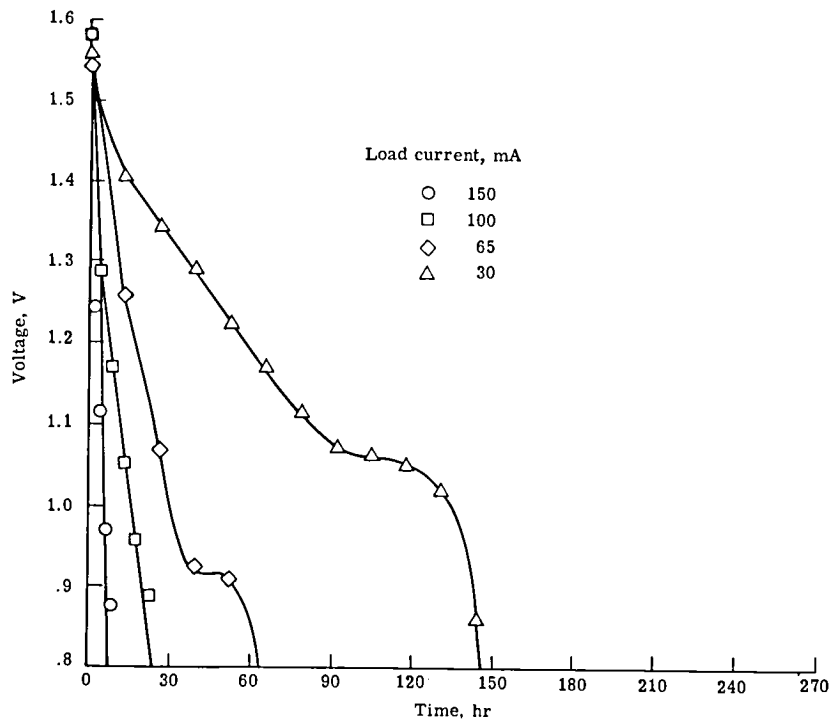

(d) $T = -20^{\circ}\text{C}$.

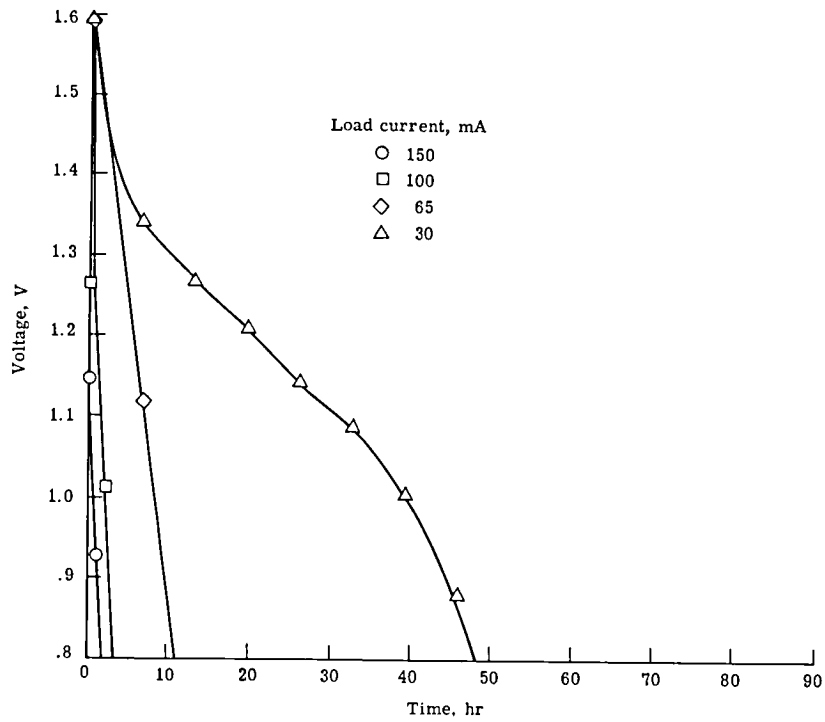

(e) $T = -40^{\circ}\text{C}$.

Figure 13.- Concluded.

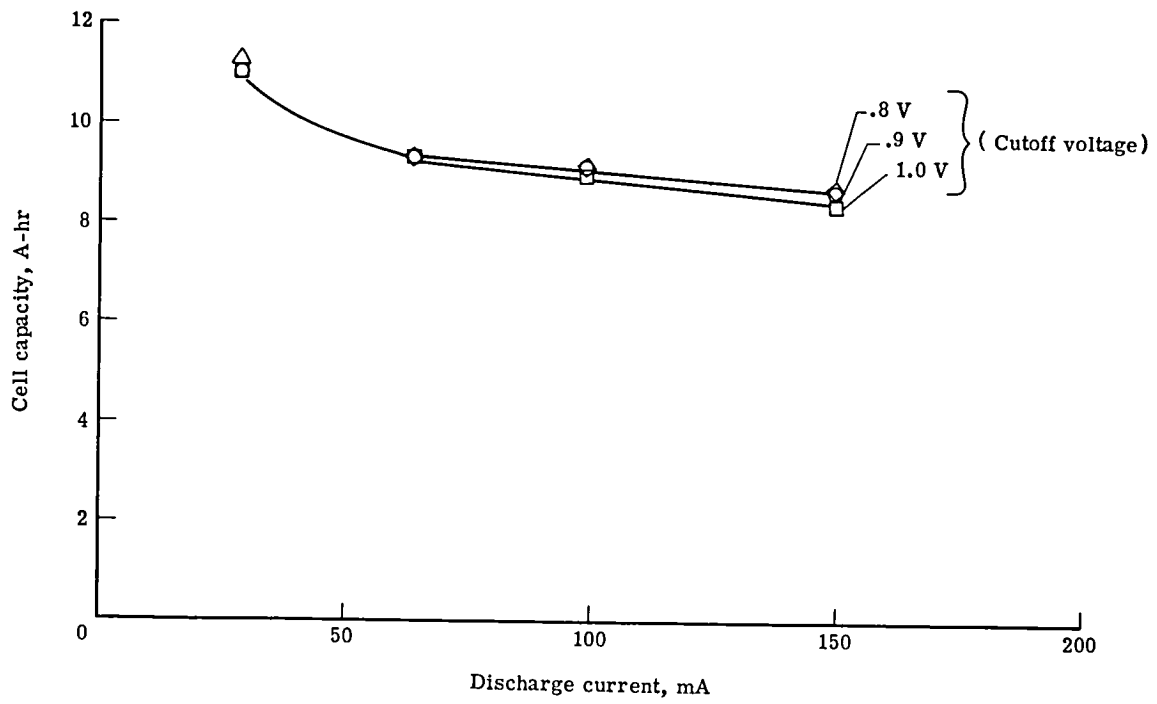

(a) $T = 55^{\circ}\text{C}$.

Figure 14.- Capacity characteristics of cells from manufacturer D.

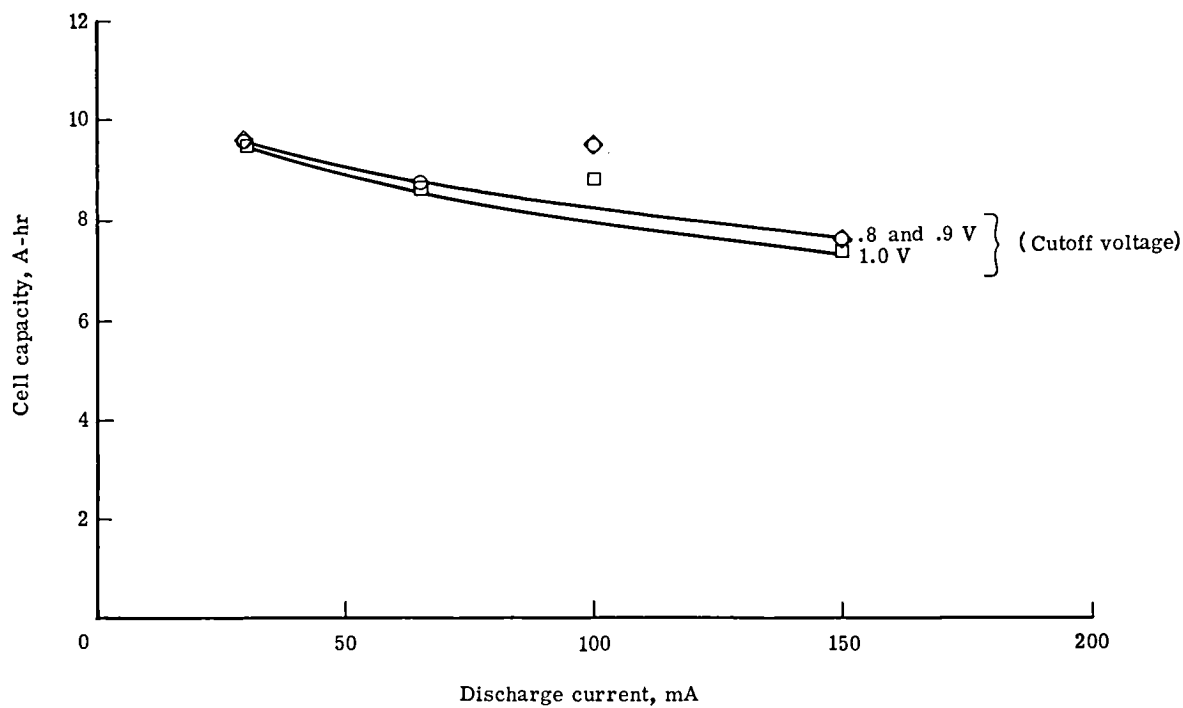

(b) T = 20°C.

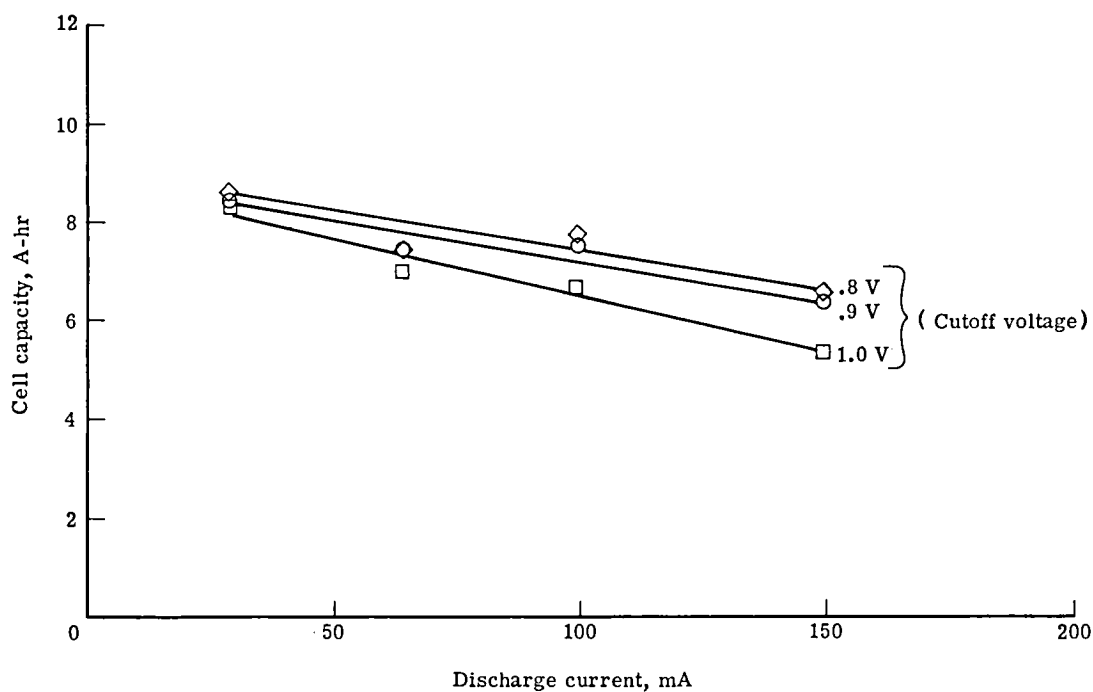

(c) T = 0°C.

Figure 14.- Continued.

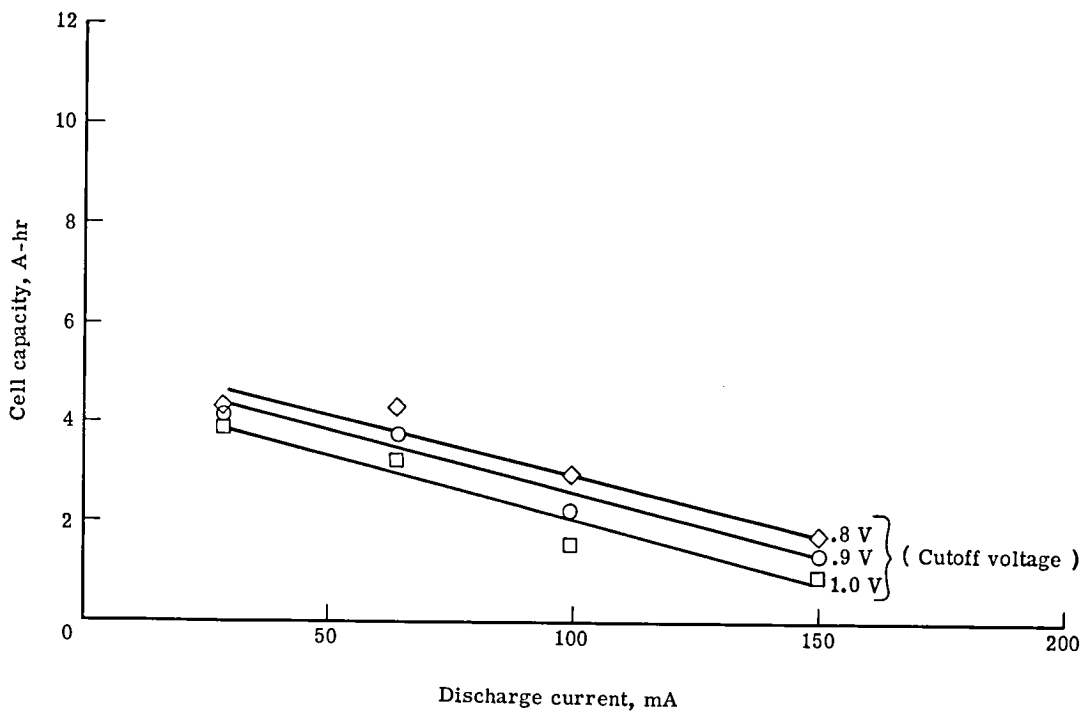

(d) $T = -20^{\circ}\text{C}$.

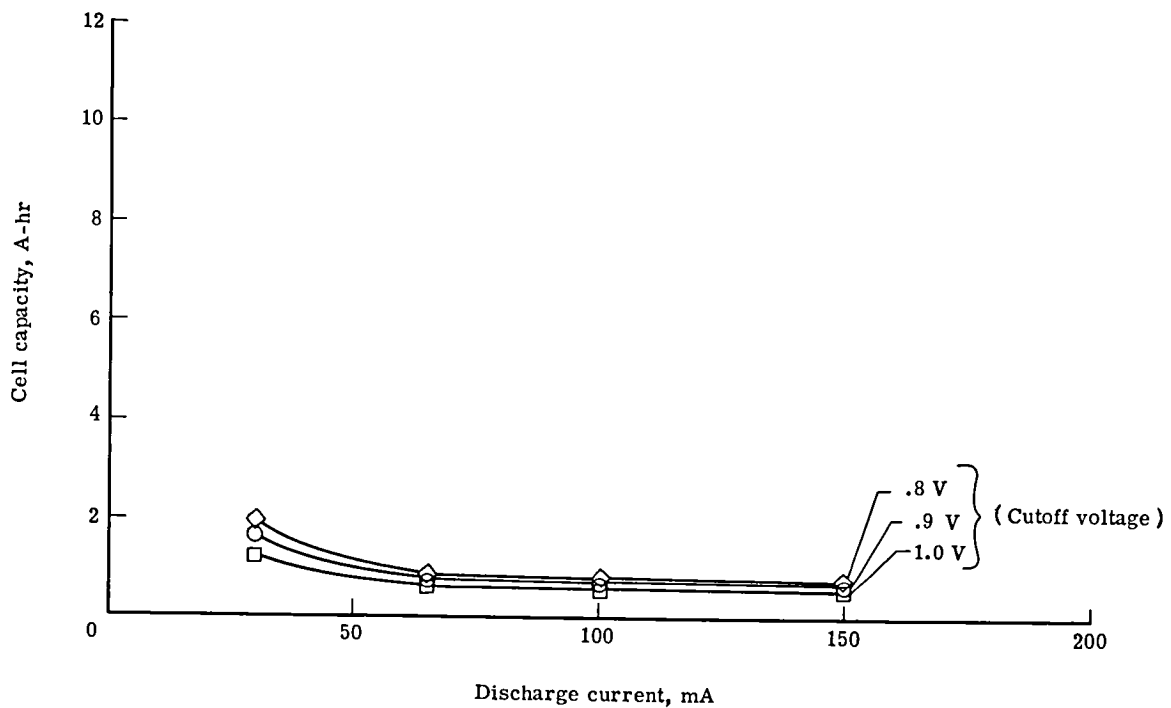

(e) $T = -40^{\circ}\text{C}$.

Figure 14.- Concluded.

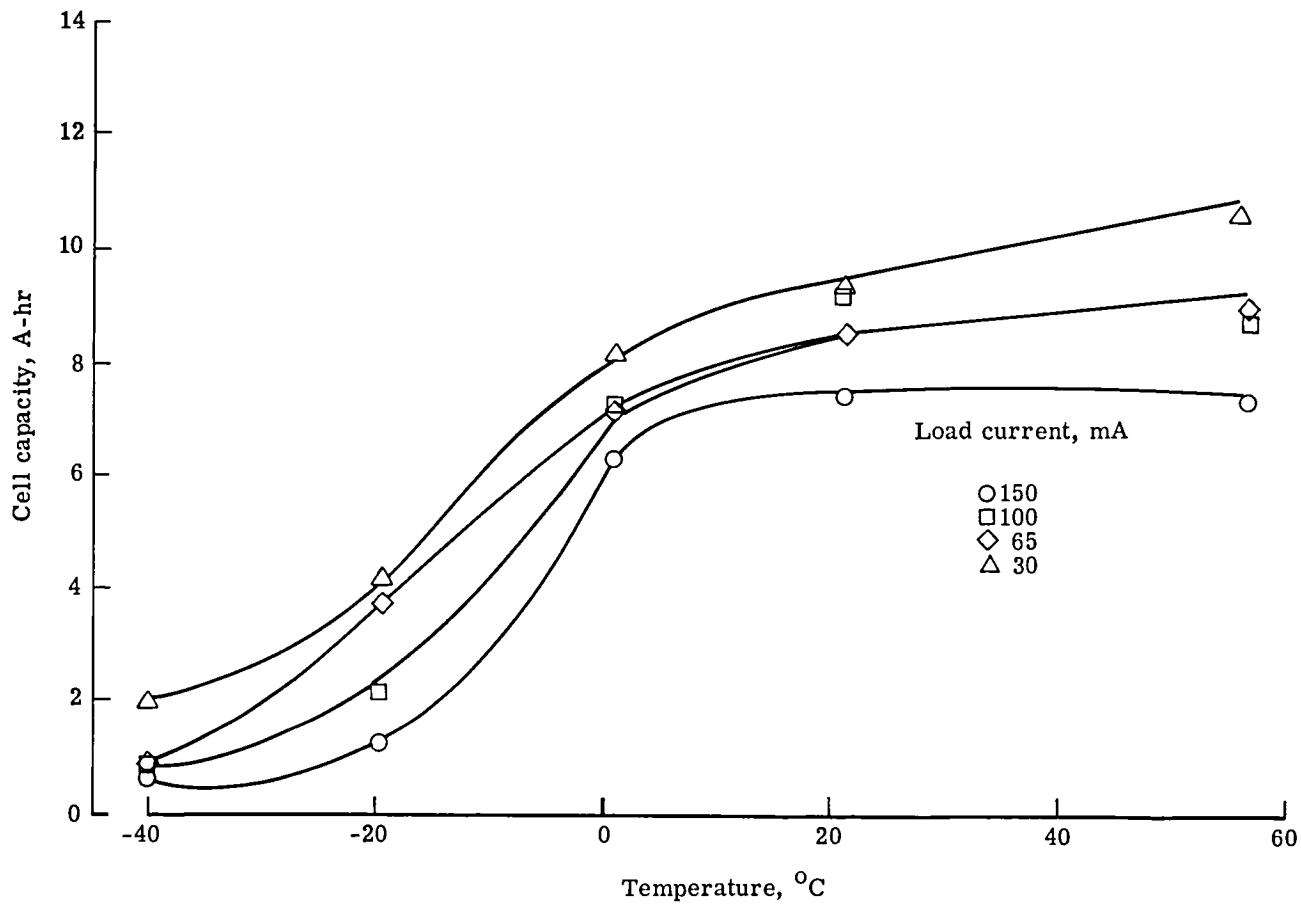
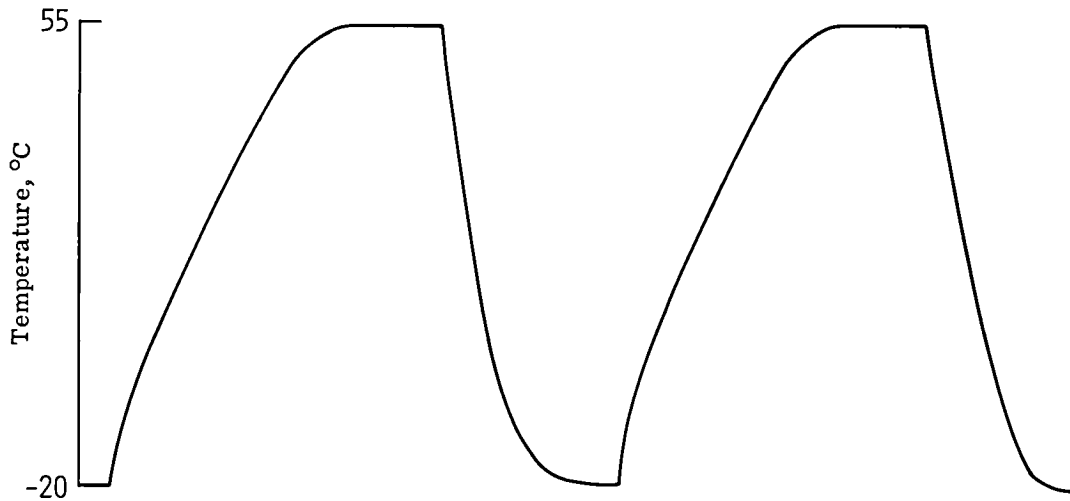
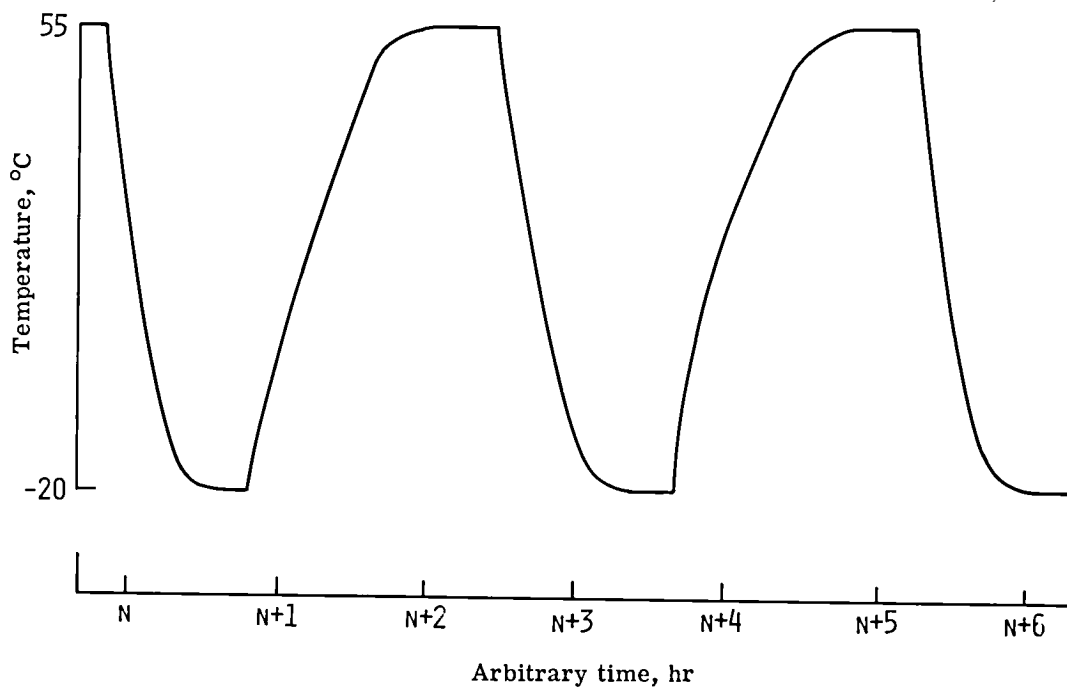

Figure 15.- Effect of temperature on capacity (0.9-V cutoff voltage) for cells from manufacturer D.



(a) Near beginning of cycle tests (cycle no. 90).



(b) Near end of cycle tests (cycle no. 525).

Figure 16.- Thermal cycle profiles to which alkaline cells were exposed.

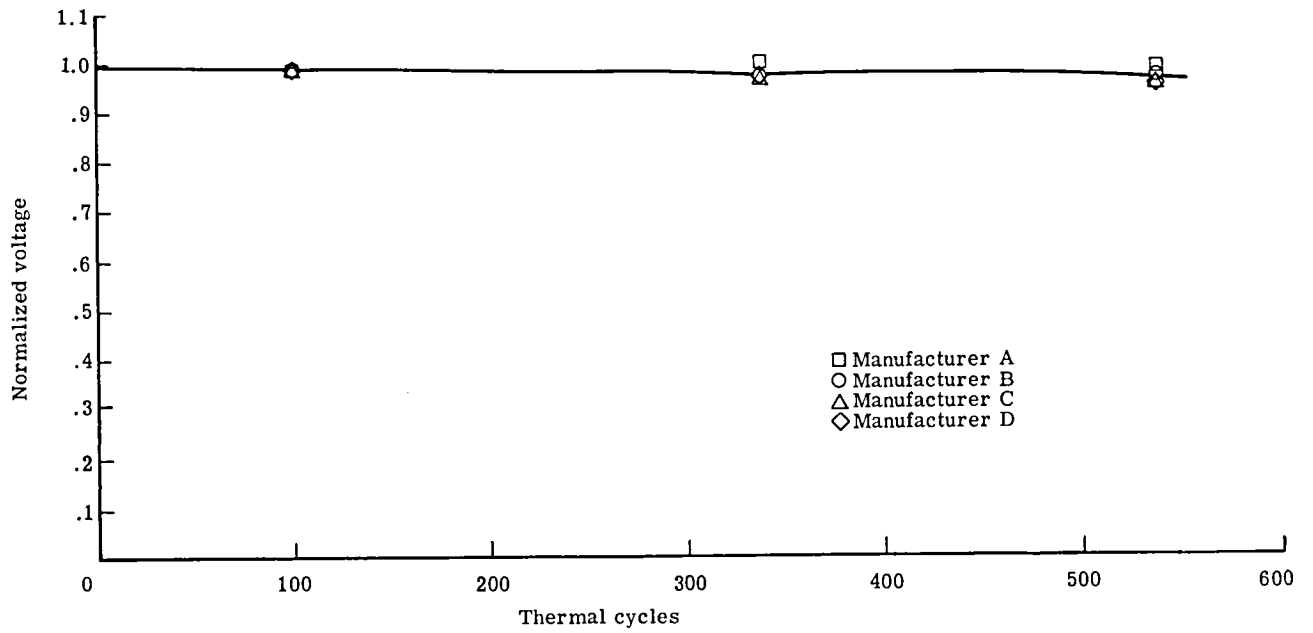

Figure 17.- Effect of thermal cycling on open-circuit voltage of alkaline cells.

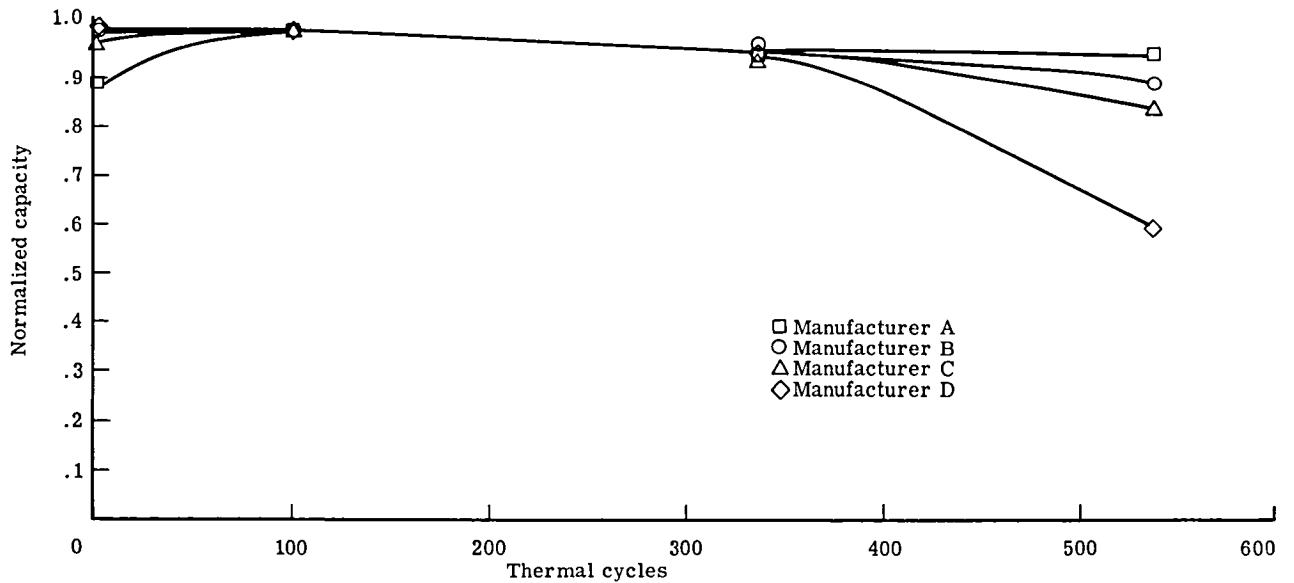

Figure 18.- Effect of thermal cycling on capacity of alkaline cells.

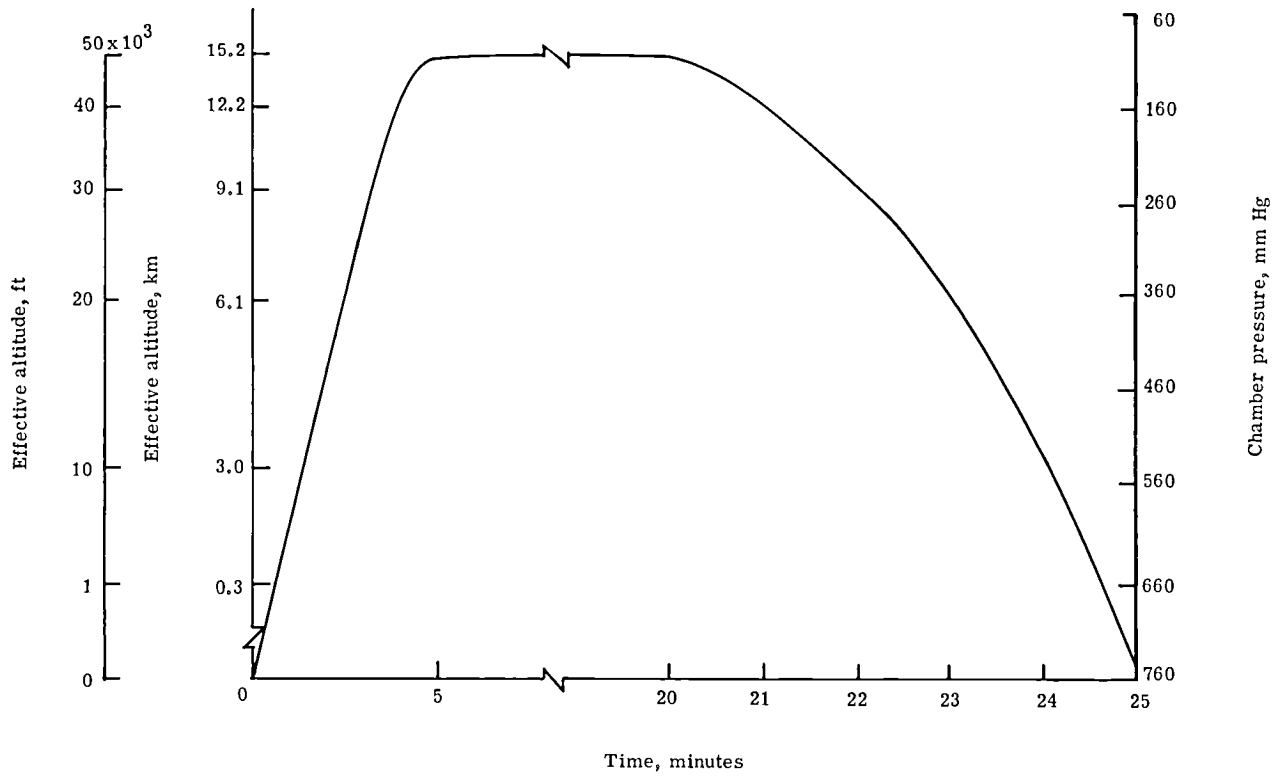

Figure 19.- Test chamber pressure profile for high-altitude exposure tests on alkaline battery cells.

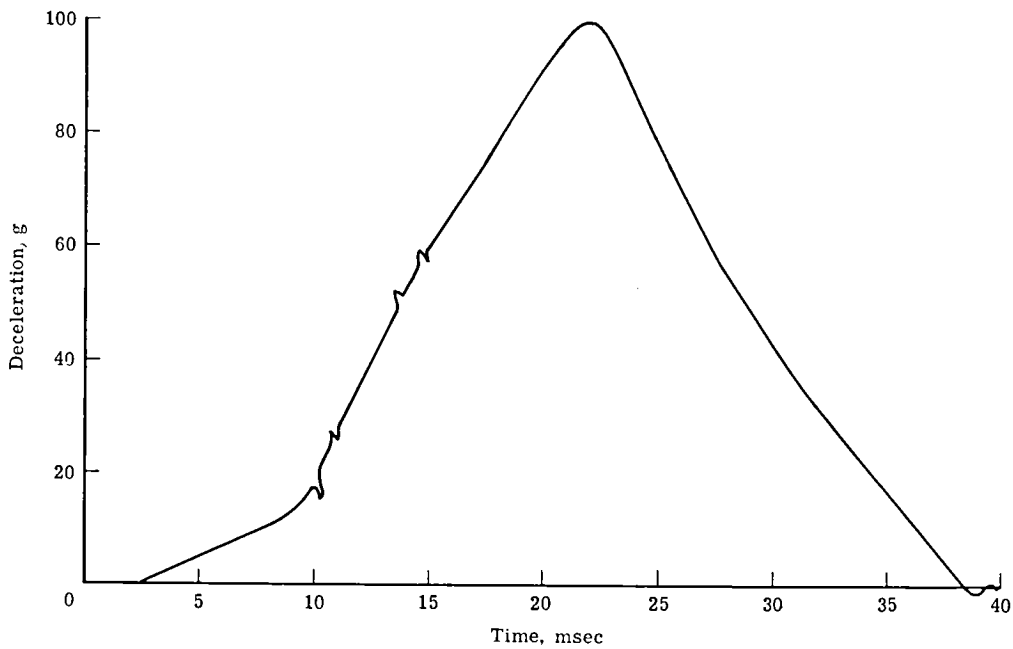
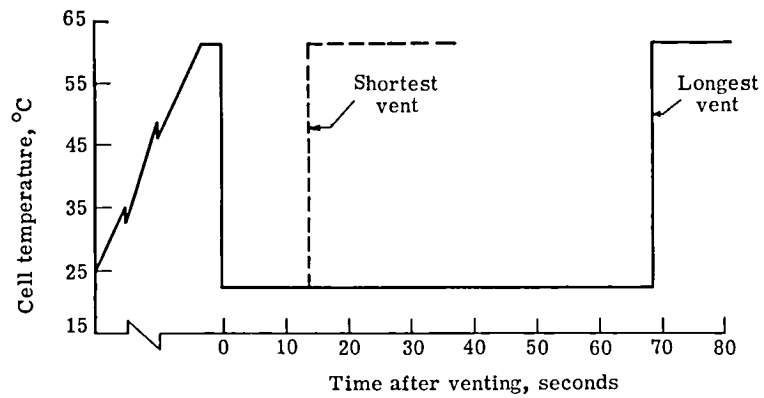
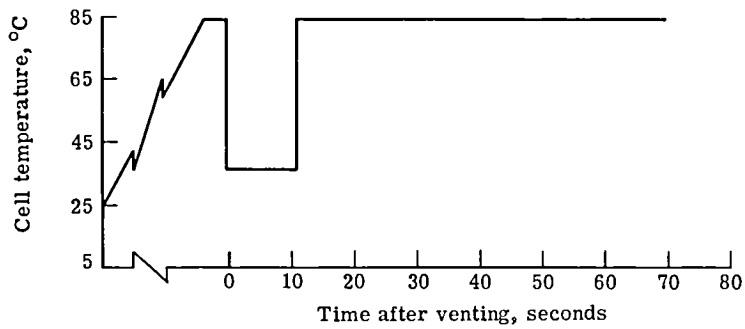

Figure 20.- Shock spectrum to which alkaline cells were exposed.



(a) Manufacturer C.



(b) Manufacturer B.

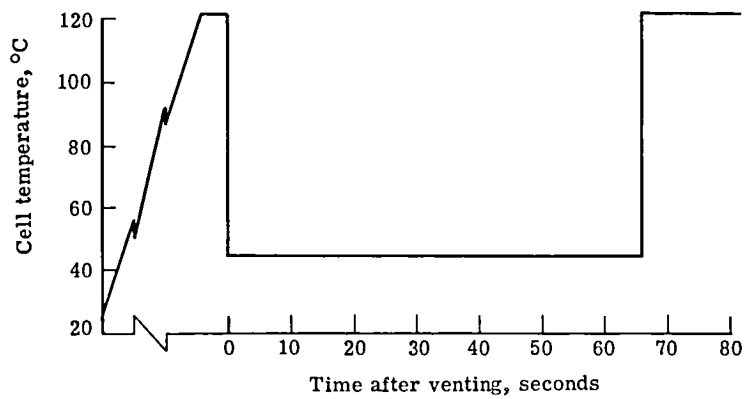

(c) Manufacturer D.

Figure 21.- Temperature indications of typical alkaline cell venting.

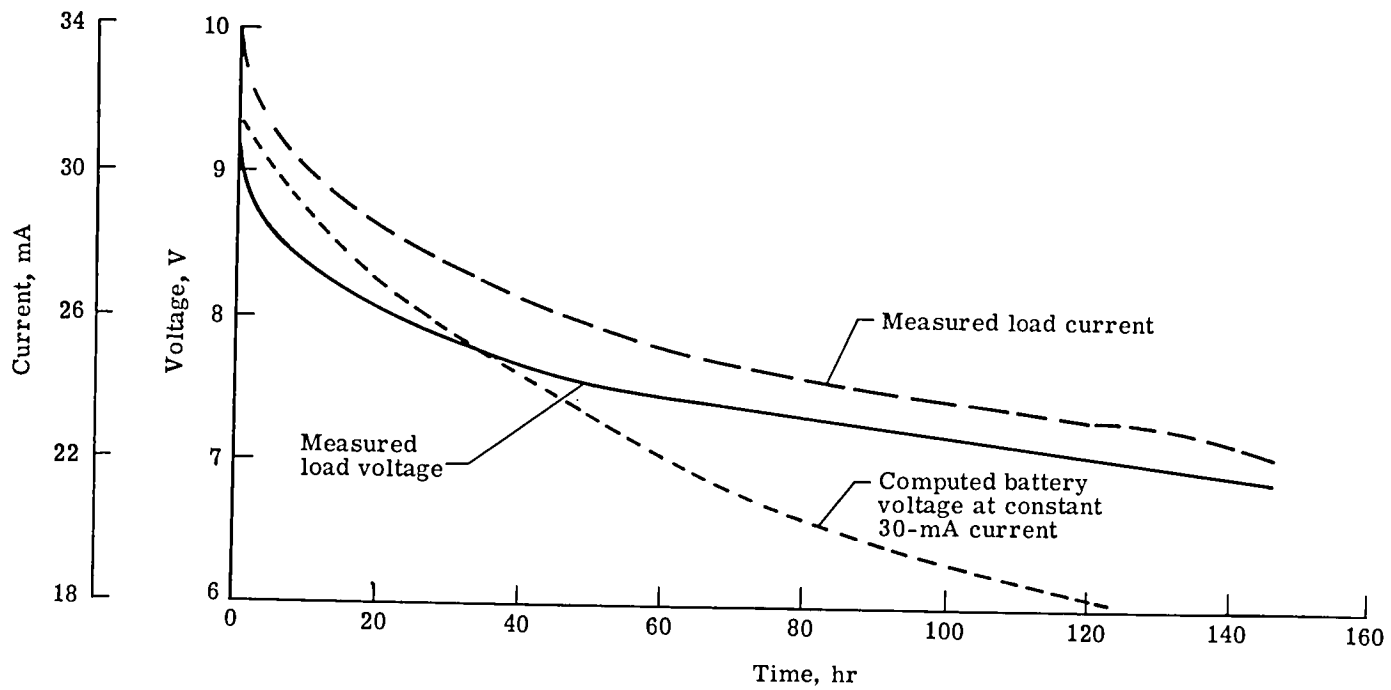

Figure 22.- Measured and computed voltage curves and measured current curve for an ELT powered by a battery made of cells from manufacturer B. $T = -20^{\circ}\text{C}$.

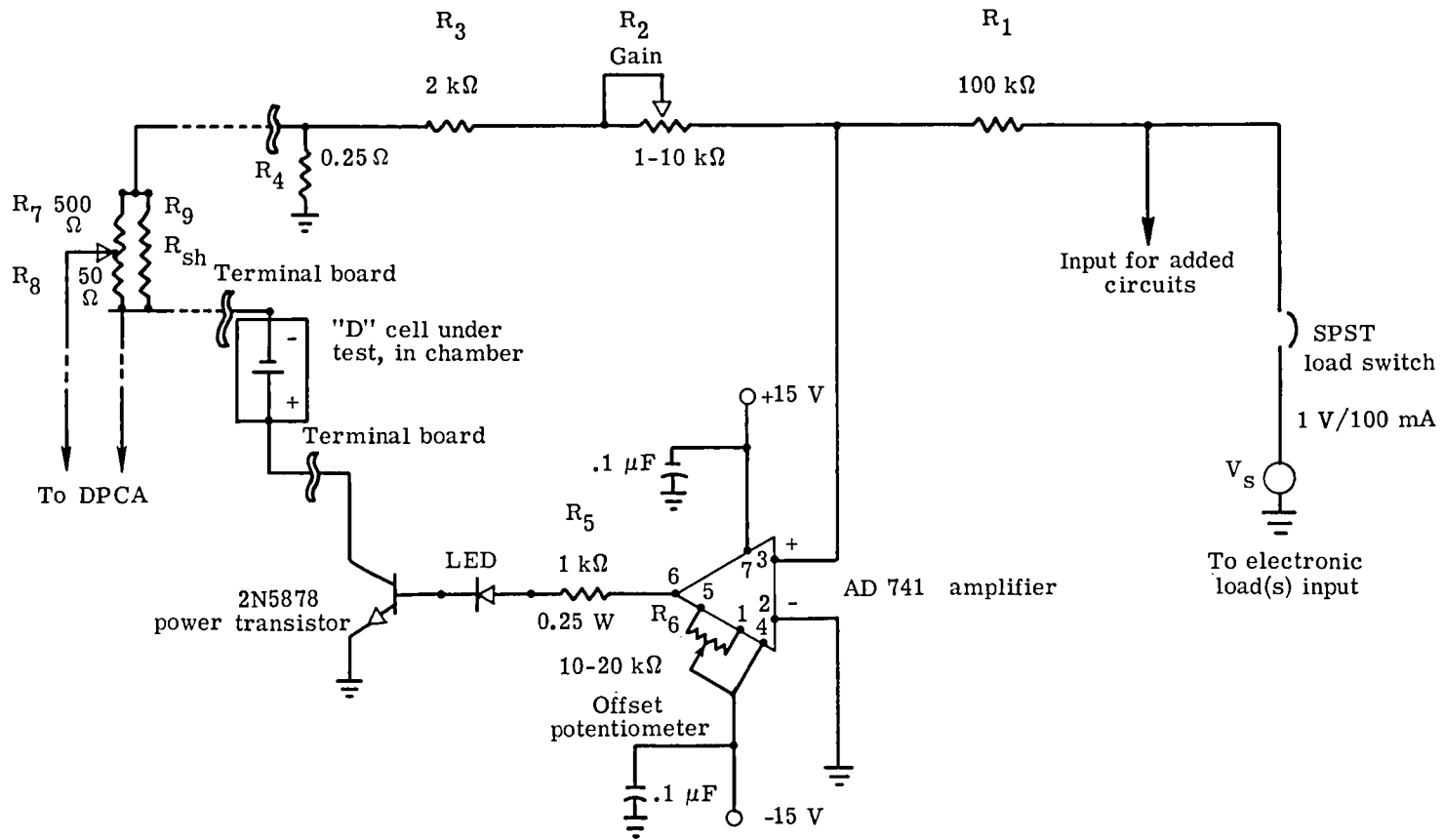

Figure A1.- ELT alkaline battery cell constant-current load circuit.

| | | | | | |
|--|--|-----------------------------|---|--|--|
| 1. Report No. NASA TP-2277 | | 2. Government Accession No. | | 3. Recipient's Catalog No. | |
| 4. Title and Subtitle PERFORMANCE OF ALKALINE BATTERY CELLS USED IN EMERGENCY LOCATOR TRANSMITTERS | | | | 5. Report Date March 1984 | |
| | | | | 6. Performing Organization Code 505-45-33-12-00 | |
| 7. Author(s) Gilbert A. Haynes, Samuel Sokol, William R. Motley III, and Edward L. McClelland | | | | 8. Performing Organization Report No. L-15496 | |
| | | | | 10. Work Unit No. | |
| 9. Performing Organization Name and Address NASA Langley Research Center Hampton, VA 23665 | | | | 11. Contract or Grant No. | |
| | | | | 13. Type of Report and Period Covered Technical Paper | |
| 12. Sponsoring Agency Name and Address National Aeronautics and Space Administration Washington, DC 20546 | | | | 14. Sponsoring Agency Code | |
| | | | | | |
| 15. Supplementary Notes | | | | | |
| 16. Abstract The characteristics of battery power supplies for emergency locator transmitters (ELT's) were investigated by testing alkaline zinc/manganese dioxide cells of the type typically used in ELT's. Cells from four manufacturers were tested. The cells were subjected to simulated environmental and load conditions representative of those required for survival and operation. The objective of the study was to evaluate battery cell characteristics that may contribute to ELT malfunctions and limitations. Experimental results from the battery cell study are discussed, and an evaluation of ELT performance while operating under a representative worst-case environmental condition is presented. | | | | | |
| 17. Key Words (Suggested by Author(s)) Alkaline batteries Emergency locator transmitters Electrochemical cells Performance tests Zinc/manganese dioxide batteries | | | 18. Distribution Statement Unclassified - Unlimited Subject Category 33 | | |
| 19. Security Classif. (of this report) Unclassified | 20. Security Classif. (of this page) Unclassified | 21. No. of Pages 58 | 22. Price A04 | | |

National Aeronautics and
Space Administration

Washington, D.C.
20546

Official Business
Penalty for Private Use, \$300

THIRD-CLASS BULK RATE

Postage and Fees Paid
National Aeronautics and
Space Administration
NASA-451



NASA

POSTMASTER: If Undeliverable (Section 158
Postal Manual) Do Not Return
