

NASA Technical Memorandum 85871

Crossed Hot-Wire Data Acquisition and Reduction System

R. V. Westphal

R. D. Mehta, Ames Research Center, Moffett Field, California

NASA

National Aeronautics and
Space Administration

Ames Research Center

Moffett Field, California 94035

TABLE OF CONTENTS

| | Page |
|--|------|
| SYMBOLS | v |
| SUMMARY | 1 |
| 1. INTRODUCTION | 1 |
| 2. EXPERIMENTAL PROCEDURE AND APPARATUS | 2 |
| Experimental Procedure | 2 |
| Experimental Apparatus | 2 |
| 3. CROSSED-HOT-WIRE RESPONSE EQUATIONS | 5 |
| Static Velocity Response: King's Law | 5 |
| Yaw Sensitivity: Cosine Law | 5 |
| Temperature Drift Correction | 6 |
| Summary: Calibration and Data-Acquisition Procedure | 7 |
| Computation of Signal Statistics | 8 |
| 4. SAMPLE RESULTS FOR A PLANE MIXING LAYER | 9 |
| 5. CONCLUDING REMARKS | 10 |
| APPENDIX -- SOFTWARE FOR THE HP9845B DESK-TOP COMPUTER | 11 |
| REFERENCES | 30 |
| FIGURES | 31 |

SYMBOLS

| | |
|-------------------------|--|
| $A(i)$ | ith (current or updated) average |
| $a(i)$ | ith sample value |
| C | temperature-shift correction constant |
| E_{corr} | corrected bridge output voltage |
| E_{meas} | measured bridge output voltage |
| E_0 | fictive no-flow bridge voltage |
| \bar{E}_{meas} | average value of the measured bridge voltage |
| i | sample number |
| K | constant |
| N_s | number of samples |
| n | log slope (about 0.45, typical value) |
| OHR | overheat ratio (usually about 1.8) |
| S_a | average of quantity a , defined by equations (15) |
| $S\langle a(i) \rangle$ | sum of $a(i)$ from $i = 1$ to $i = N_s$ |
| T | current flow temperature |
| T_{cal} | calibration flow temperature |
| U | calibration velocity |
| U_{eff} | effective cooling velocity |
| $[U_{\text{eff}}]$ | the vector of effective cooling velocities |
| u, v, w | instantaneous velocity components in x, y, z directions |
| $[V]$ | instantaneous velocity vector |
| $ V $ | magnitude of the velocity vector |
| x, y, z | Cartesian coordinate directions |
| α | wire resistivity coefficient (typical value for tungsten = 0.005 per °C) |
| δ | yaw calibration angle setting |
| ψ | yaw angle |

$[\psi]$ angular sensitivity matrix

Subscripts:

1,2 used to denote a particular quantity referred to wire 1 or wire 2

uv,uw quantity determined in uv or uw measurement plane

Superscripts:

' fluctuating quantity, e.g., $u = \bar{u} + u'$, or used to indicate an intermediate quantity (e.g., eq. (11))

- time average

SUMMARY

The report describes a system for rapid computerized calibration acquisition, and processing of data from a crossed hot-wire anemometer. Advantages of the system are its speed, minimal use of analog electronics, and improved accuracy of the resulting data. Two components of mean velocity and turbulence statistics up to third order are provided by the data reduction. The report presents details of the hardware, calibration procedures, response equations, software, and sample results from measurements in a turbulent plane mixing layer.

1. INTRODUCTION

A system for rapid computerized acquisition and processing of analog signals from a hot-wire anemometer is described. Most of the discussion considers the crossed-wire anemometer; the simpler case of a single wire is briefly addressed. The objective of the work was to develop a system for measuring the statistical properties of the velocity field of a moderately turbulent, two-dimensional, incompressible, isothermal air flow. This report is intended to document the system for reference in several researches in which the system will be applied.

A crossed hot-wire probe operated by constant-temperature bridges (CTA) can provide a signal from which the two instantaneous components of velocity and related statistical properties of a moderately turbulent flow may be derived. Traditionally, analog hardware is used to linearize and process the signals from multichannel CTA systems. More analog hardware is required to process and average the resulting signals to obtain the desired statistics; for example, u'^2, v'^2 and $u'v'$ for a crossed-wire. The present report describes a more modern approach wherein all nonlinear analog processing hardware is replaced by a computerized system for probe calibration, data acquisition, and reduction. The approach described differs from the old fully analog methods in that it uses fewer, more stable electronic components, and, more importantly, is much faster. Complete calibration and acquisition for a typical 20-point profile required less than 60 min. Corrections (e.g., of ambient temperature drift) are easily implemented in software. Although specific hardware with particular response equations are presented, the approach taken is very general and could be easily adapted to different measurement conditions, other types of anemometers, or three-wire probes.

The experimental procedure and apparatus are discussed in detail in the next section. Hot-wire response equations — which give simple but accurate relations for the cooling law, directional sensitivity, and the effects of ambient temperature drift — and algorithms for computing desired statistical signal properties, such as mean, variance, and higher-order cross-correlations, are presented in the third section. Sample results from an experiment to measure turbulence quantities in a plane mixing layer are provided in the fourth section, and concluding remarks are presented in the final section. Software for both single- and crossed-wire systems written in BASIC to run on the HP 9845B desk-top computer is included in the appendix.

2. EXPERIMENTAL PROCEDURE AND APPARATUS

Experimental Procedure

The hardware configuration of the system is conceptually simple and requires little routine adjustment. Two DISA constant-temperature bridges were employed to drive the crossed-wires. A fixed dc shift and gain were applied to the bridge outputs which were low-pass filtered (to remove high-frequency electrical noise) and then input to a bipolar 12-bit A/D converter. An external clock generated a sample pulse (typical sampling rate was 500 Hz) to the A/D which caused the two inputs to be frozen ("sample-and-hold"). These channels were sequentially converted; the converted values passed through a multiplexer to a high-speed, 16-bit parallel interface to the computer. After filling the computer's data buffer, raw data were written to floppy disk. The raw data were reduced off-line to provide the signal statistics. Before data acquisition began, a complete system calibration check was performed, and relevant quantities were written to the floppy-disk data files. Taking up to 3,000 samples per data point required less than 2 min; the calibration procedure required about 15 min. Thus, a typical 20-point profile required less than a hour for data acquisition (including calibration), using the program shown here (see appendix sec. A.1.2). The current off-line data reduction program (see appendix sec. A.1.3) took about 45 min to reduce these data.

Simple but established models have been implemented to describe the sensitivity of the constant-temperature hot-wire to variations in flow velocity, wire orientation, and ambient temperature drift. The relations selected are applicable to incompressible, isothermal flow of "clean" (filtered) air over a fine wire with "moderate" local turbulence intensity (less than about 30%) and negligible instantaneous local flow reversal frequency. King's law was used to provide a relation between the "effective" cooling velocity and the bridge output. A "cosine law" was used to relate the effective cooling velocity to the magnitude and direction of the velocity vector. The entire calibration was shifted to account for the effects of small ambient temperature changes over the course of a run, based on the overheat ratio and wire resistivity. Once the King's law calibration was implemented and shifted for ambient temperature drift, the effective velocities measured by each wire were used to solve for the instantaneous velocity components in the measurement plane by inverting the angular sensitivity matrix. Then the instantaneous values of the velocity components were used to form the statistical properties of the signal. Computed results included the mean and variance, as well as second- and third-order cross-correlations (i.e., u , v , u'^2 , v'^2 , $u'v'$, u'^2v , v'^2u' for wires in the u - v plane).

Experimental Apparatus

Figure 1 shows the system hardware schematically and provides a list of component manufacturers and model numbers. In the following discussion of the hardware, the system is divided into four areas: (1) probes used, (2) DISA bridges and signal conditioners, (3) NASA LDV-A/D computer interface, and (4) HP computer interface, desk-top computer, and floppy-disk drive. Little explicit mention will be made of the digital voltmeter or oscilloscope, which are used to monitor the analog signals, or of the pulse generator, which provides a sample trigger to the A/D converter.

Crossed-wire probes- Miniature crossed-wire probes were manufactured in-house at Ames. These probes had two nominally perpendicular wires mounted at angles of about

$\pm 45^\circ$ to the probe stem (see fig. 2). The planes that contain each wire and its two support needles were parallel and separated by about 1 mm. The wires were 5- μ m tungsten elements about 1 mm long; they were welded to the supports. The "cold" (room-temperature) resistance of each wire was about 5 ohms, and the operating over-heat ratio used was 1.8 (ratio of hot, or operating, resistance to cold, or unheated, wire resistance). The probe tips were mounted in a stem which was in turn held in a rotating collar. A spring-loaded mechanism in the collar could be rotated to yaw the probe in five fixed positions in 5° increments. In this way, yaw calibration of the wire was performed. Often it was convenient to mount the probe so that the axis of rotation of the collar was parallel (rather than perpendicular) to the desired plane of measurement. Then a special procedure was used wherein the yaw calibration was performed in the u-w plane, but the probe was then rotated about the stem axis for measurement in the u-v plane (see Summary: Calibration and Data-Acquisition Procedure in the next section).

Bridges and signal conditioners- Two DISA 55D31 bridges were used to operate the crossed hot-wires at constant temperature. The cable resistance was compensated for using a shorting probe. The probe resistance was measured, and the operating resistance of each probe was set at 1.8 times the cold resistance; this is a nominal value, because the operating resistance was not changed to account for daily changes in ambient temperature. However, the frequency response was checked daily as described below.

The frequency response of each channel was optimized using the internal 1-kHz square-wave generator and varying the bridge gain (as well as the cable compensation adjustments). Typically, the "3-dB-down" point was about 20 kHz on each channel (Freymuth method). A bridge gain of 4 and an HF filter setting of 2 were usual values. The bridge output voltage ranged from about 3 V (no-flow) to about 4.7 V (25 m/sec flow velocity); since the input voltage range of the available A/D converter was -10 to +10 V (with 12-bit resolution), linear signal conditioning elements were used to obtain better resolution of the bridge output voltage.

Commercial signal conditions manufactured by DISA (model 55D26) were used to dc shift, to amplify, and to low-pass filter the bridge outputs before A/D conversion. A dc shift of about 4 V and a gain of 10 were applied to each channel, yielding a voltage covering most of the ± 10 -V range of the 12-bit A/D converter. Note that the exact values of the gain and offset used were calibrated during setup of the system for each run (see the description of the software below), so that it was not necessary for the actual gain or offset to be determined from the nominal settings. The low-pass filter cutoff was 10 kHz with 18 dB/octave roll-off; the high-pass stage was set to "direct." The filtering was intended to eliminate spurious electrical noise which would contaminate measurements of low turbulence intensity.

NASA LDV-A/D computer interface- Two channels of the A/D conversion stage of the NASA LDV-A/D computer interface (ref. 1) were used to convert the conditioned signals to digital form and multiplex them to the HP computer interface (described below). Figure 1 shows how the NASA LDV-A/D fits into the measurement system, and figure 3 gives the details of the various settings and connections for the interface. A sample pulse was generated by a Tektronix PG 508 pulse generator and applied to the "channel 1 event" and "external reset" inputs. This signal acted as a sampling trigger to initiate a "sample-and-hold" of the two A/D inputs when the interface was enabled by the computer setting "CTL0."

Four 16-bit TTL data words were then multiplexed to the computer. The first word gave the time between samples (a count dependent on the operating mode (see ref. 1 for

details)); these data were typically discarded after verifying that the nominal sample rates were actually attained. The second word gave status information; it was also checked then discarded. The third and fourth words were the two channels of anemometry data in directly computer-compatible integer representation. Since the A/D that was used had only 12 bits of resolution, this required that the upper 4 bits be either all 0's or all 1's, depending on whether the converted voltage was positive or negative, respectively. Thus, the converted A/D data could take on integer values of -2,048 to +2,047, inclusive.

An important feature of the NASA LDV-A/D hardware was the fast sample-and-hold hardware. The measurement strategy required that the two channels be sampled simultaneously so that the instantaneous-velocity vector components in the measurement plane could be determined. Since the frequency response of the anemometer was limited to about 20 kHz, it was desirable that the two signals be sampled within, say, 10 μ sec or so. The sample-and-hold hardware in the LDV-A/D was capable of locking in the input analog signal within 0.5 μ sec of receiving the sample trigger. Then the A/D conversion and multiplexing could take place asynchronously (as long as all four words were passed before the next sample pulse). For each A/D conversion, a minimum of 14 μ sec were required.

HP computer and parallel interface- Multiplexed data were passed to the HP computer from the NASA LDV-A/D using the HP 98032A high-speed 16-bit parallel interface. Jumpers labeled "9,B,D" were connected inside the 98032A for proper operation with the LDV-A/D. A select code of 10 (screw setting on the 98032A) was set for use with the software described in the appendix.

A data buffer of 24 kbytes was provided in the memory of the HP 9845B desk-top computer for storage of up to 3,000 samples obtained from one measurement location (four words of 2 bytes each are passed from the LDV-A/D). Since two of the four data words passed for each sample were merely monitored and discarded as described above, 12 kbytes of raw data remained to be stored for each point. An HP 9895A floppy-disk drive was used for archival storage of raw data. The buffered data were written in real time to a sequential-access floppy-disk file. Enough header information was written to each file to identify the run, as well as to reproduce calibration tables and correct for ambient temperature drift. About 1 min per point was required for storing the data on floppy disk.

Fairly rapid and simple data buffering was possible with the HP computer, using convenient high-level commands. Sampling rates as high as 10,000 samples per second were used (indicating interface transfer rates 4 times as high in 16-bit words per second). Direct memory access (DMA) was not used; the processor was simply dedicated to the real-time task.

The system described above was also streamlined for the simplified case of single-channel, hot-wire anemometry. Of course, just half the hardware shown before the A/D in figure 1 was needed. The calibration procedure consisted of simply setting up the signal conditioner and compiling the King's law data. On-line data reduction was implemented, since this could be done rapidly with only one channel. Thus, the look-up table was constructed immediately following the static velocity calibration and implemented after filling each data buffer. Mean and fluctuating values of velocity were stored; raw data were not usually archived.

A DISA 55P11, platinum-plated, tungsten hot-wire was used for the single-wire work. The overheat ratio and bridge setup were exactly as described earlier. The BASIC program to run the single-wire anemometry system is provided in the appendix.

3. CROSSED-HOT-WIRE RESPONSE EQUATIONS

Simple relations that describe the response of a fine, heated wire to variations in flow velocity, orientation, and ambient temperature drift have been incorporated into the off-line data reduction program. Of course, the equations selected have a strong effect on the type of calibration performed and on the accuracy of the results. The response equations are first discussed separately, the calibration procedure is summarized, and the algorithms actually used for implementing the response equations and computing the signal statistics are then given.

Static Velocity Response: King's Law

The effective, instantaneous wire velocity was assumed to be related to the bridge output voltage by the generalized King's law:

$$U_{\text{eff}} = K(E_{\text{eff}}^2 - E_0^2)^{1/n} \quad (1)$$

This is an approximate relation which has been determined to be fairly accurate in describing the steady-flow heat loss over cylinders in cross-flow; the (constant) value of the log slope n selected (0.45) provides a good fit to experimental data at moderate-to-low Reynolds numbers, based on wire diameter. Our steady-flow calibration data fit King's law with an rms error of 0.5% over the range of 5-25 m/sec. Although simple interpolation or polynomial fit of the calibration may seem equally acceptable, the log-linear King's law fit provides a quick way to evaluate whether the calibration is "typical," and it smooths minor "jitter" in the calibration data. Also, the King's law calibration may be confidently extrapolated slightly outside the range of the actual calibration data.

Yaw Sensitivity: Cosine Law

The "effective cooling velocity" is taken to be that component of the velocity vector perpendicular to the wire. This assumption implies that a wire yawed in a uniform constant-velocity stream will respond to an effective flow velocity that is proportional to the cosine of the yaw angle (see fig. 2 for nomenclature). Neglecting the axial component of velocity (along the wire axis) is strictly an approximation — one that is often made, however, and one that works quite well for moderately turbulent flows.

$$U_{\text{eff}} = |V| \cos \psi \quad (2)$$

For two wires at angles ψ_1 and ψ_2 to the reference coordinate direction, the following two equations result, if sensitivity to out-of-plane velocity fluctuations is neglected:

$$\begin{aligned} U_{\text{eff}1} &= u \cos \psi_1 + v \sin \psi_1 = K_1(E_1^2 - E_{01}^2)^{1/n_1} \\ U_{\text{eff}2} &= u \cos \psi_2 + v \sin \psi_2 = K_2(E_2^2 - E_{02}^2)^{1/n_2} \end{aligned} \quad (3)$$

Here u and v are the instantaneous velocity components in the measurement plane. Note that U_{eff} for each wire may be found immediately from the King's law

calibration; only the bridge voltage must be known. A matrix form more convenient for discussion or generalization is

$$[U_{\text{eff}}] = [\psi][V] \quad (4)$$

The entries for the angular sensitivity matrix are found by a yaw-calibration procedure described below. Then, the inverse of this matrix is computed once and stored. Solution for the instantaneous velocity components is simple:

$$[V] = [\psi]^{-1}[U_{\text{eff}}] \quad (5)$$

The explicit solution of equation (3) gives the equations actually used to compute the instantaneous velocity components:

$$\left. \begin{aligned} u &= \frac{(\sin \psi_1)U_{\text{eff}2} - (\sin \psi_2)U_{\text{eff}1}}{(\sin \psi_1)(\cos \psi_2) - (\cos \psi_1)(\sin \psi_2)} \\ v &= \frac{(\cos \psi_2)U_{\text{eff}1} - (\cos \psi_1)U_{\text{eff}2}}{(\sin \psi_1)(\cos \psi_2) - (\cos \psi_1)(\sin \psi_2)} \end{aligned} \right\} \quad (6)$$

Temperature Drift Correction

Temperature drift of a few degrees Fahrenheit is commonly encountered and has some effect on measurement accuracy since the probe is operated at constant temperature. For typical wire-overheat ratios and sensor resistivity properties, the temperature difference between the wire and flow is a few hundred degrees Fahrenheit, so that a few degrees drift will change the perceived heat-transfer coefficient between wire and flow by a percent or so. A small correction to the bridge voltage is applied to account for this variation in ambient temperature:

$$\frac{E_{\text{corr}} - E_{\text{meas}}}{E_{\text{meas}}} = \frac{\alpha}{2(\text{OHR})} (T - T_{\text{cal}}) \equiv C \quad (7)$$

where C represents the percent shift required for the instantaneous bridge voltage — fixed by the operating parameters and current-flow temperature. Since fluctuations in the bridge voltage are fairly small, a further simplifying approximation is that the instantaneous bridge voltage can be simply shifted by the fixed percentage of the average output voltage. Then the calibration is easily implemented after the shift is computed and applied to each voltage reading. The equation actually used is then

$$E_{\text{corr}} = E_{\text{meas}} + C \times \bar{E}_{\text{meas}} \quad (8)$$

Note that each voltage reading is corrected for ambient temperature changes. The correction will, therefore, influence both mean and fluctuating time-averaged results, as it should.

Summary: Calibration and Data-Acquisition Procedure

Figure 4 shows a flowchart that represents the verbal description of the calibration and data-acquisition procedure below. The calibration consisted of four steps performed for each channel: (1) in-place calibration of the A/D converter and DISA signal conditioner; (2) static calibration for determining the King's law constants; (3) yaw calibration with wires in the u-w plane; and (4) recalibration to determine the effective angle in the measurement plane (if different from the u-w plane). Data acquisition with the calibrated system consisted of acquiring the data from the two channels in a buffer then dumping the buffer with identifying information to a floppy-disk file.

The shorted-input reading of the A/D converter can drift a few bits from the nominal value of 0 and was, therefore, checked for each run. Then a reference dc voltage was measured with the signal conditioners bypassed. An offset value was then fixed on the dc offset stage of the DISA 55D26 conditioner and the offset was deduced by measuring the A/D value for the known reference with added offset. Finally, a gain was applied to the offset reference voltage through the amplifier section of the DISA conditioner. The effective value of the gain factor could be deduced since the input reference voltage and offset were accurately known. From the known calibration constants, the bridge output voltage could be accurately computed from the measured A/D converted value.

Static calibration of the wire velocity response was performed with the wire at fixed orientation in a steady flow of variable velocity. Note, however, that the actual orientation is not yet known, but is to be determined through calibration. If the calibration velocity is taken to be U , then, from equation (2),

$$U_{\text{eff}} = U \cos \psi \quad (9)$$

where ψ is the angle between the calibration velocity vector and the wire. We first aligned the probe so that the wires lay in the u-w plane; this wire angle is called ψ_{uw} . With equation (1), this yields

$$U = K'_{\text{uw}} (E^2 - E_0^2)^{1/n} \quad (10)$$

where

$$K'_{\text{uw}} = K / (\cos \psi_{\text{uw}}) \quad (11)$$

Thus, the constants K'_{uw} and E_0^2 were determined from a straightforward, linear, least-square fit of the calibration data with n specified (n is dependent on the calibration range; we used $n = 0.45$ for $5 < U < 25$ m/sec). Next, ψ_{uw} was determined via direct yaw calibration (see below); K was then computed from equation (11).

The wires are now set at various known angles to the calibration flow in order to determine the "effective" wire angle ψ_{uw} . The calibration velocity was held constant in magnitude and direction at a value of about 70% of the maximum calibration velocity. If the yaw angle relative to the effective angle ψ_{uw} is denoted δ , then equation (3) can be used to derive an equation that relates the bridge output for $\delta = 0$ to the output for a particular value of δ ; rearranging yields an expression for the effective wire angle ψ_{uw} :

$$\tan \psi_{uw} = \frac{\cos(\delta_1) - \frac{U_{eff}(\delta = \delta_1)}{U_{eff}(\delta = 0)}}{\sin(\delta_1)} \quad (12)$$

In practice, we computed ψ_{uw} for four different values of delta of -10° , -5° , 5° , and 10° . These results were averaged to get the value of ψ_{uw} .

Now the system is calibrated for measurement in the u-w plane. When measurements in the u-v plane were desired, one further step was required. The probe stem was first rotated 90° to position the wires in the u-v plane. At this point, the effective wire angle ψ_{uv} is unknown; although ψ_{uv} would be nominally the same as ψ_{uw} , it can be slightly different because of slight pitching of the probe stem. Another static velocity calibration was performed as described above. However, this time n and E_0^2 were fixed when the King's law was fitted to the data; K'_{uv} was found by linear least-square fit, then ψ_{uv} was computed as before:

$$\cos(\psi_{uv}) = K/K'_{uv} \quad (13)$$

Data acquisition now took place. Identifying information regarding, for example, run number and probe position, was entered from the keyboard. The current flow temperature (measured with a thermocouple and digital readout) was also entered from the keyboard. Then the data buffer would be filled. A few samples were used to compute the average bridge voltage for use in computing the temperature shift. The temperature correction shift was written to the floppy-disk data file along with the identifying information, calibration data, and the raw data buffer; 25 kbytes were provided for each data file. Probe calibrations were fairly stable and repeatable for several hours of running, so that 60-100 data points could be reduced using the same calibration constants with the ambient drift correction.

Computation of Signal Statistics

Figure 5 is a flowchart of the data-reduction algorithm for computing signal statistics. Starting with raw data written into floppy-disk files as described above, the data reduction began with construction of a look-up table from which a velocity could be assigned to any raw A/D voltage. This simply required that for every possible A/D reading, the King's law calibration be used to compute a corresponding effective flow velocity, U_{eff} . Then, after adding the temperature correction shift to each reading, the table was entered for every raw data sample. The result for a single reading would be two values of U_{eff} - one from each channel of the crossed wires. Equation (6) was then used to compute the values of the instantaneous velocity components u and v. Once the calibration was implemented and the instantaneous-velocity vector components computed for each raw data point pair, the various signal statistics were computed. It is noteworthy that wherever reference is made to an average value, the average is computed using the "running average" formula:

$$S\langle a(i) \rangle = A(i = N_s) \quad (14)$$

where

$$A(i) = A(i - 1) + [a(i) - A(i - 1)]/i \quad (15)$$

Average values of the various moments were computed as defined below:

$$\left. \begin{aligned}
 S_u &= S\langle u(i) \rangle / N_s \\
 S_v &= S\langle v(i) \rangle / N_s \\
 S_{uu} &= S\langle u(i)u(i) \rangle / N_s \\
 S_{uv} &= S\langle u(i)v(i) \rangle / N_s \\
 S_{vv} &= S\langle v(i)v(i) \rangle / N_s \\
 S_{uuv} &= S\langle u(i)u(i)v(i) \rangle / N_s \\
 S_{uvv} &= S\langle u(i)v(i)v(i) \rangle / N_s
 \end{aligned} \right\} \quad (16)$$

Using these definitions, the signal statistics were then computed assuming nearly infinite sample size:

$$\left. \begin{aligned}
 \bar{u} &= S_u \\
 \bar{v} &= S_v \\
 \overline{u'^2} &= S_{uu} - S_u S_u \\
 \overline{v'^2} &= S_{vv} - S_v S_v \\
 \overline{u'v'} &= S_{uv} - S_u S_v \\
 \overline{u'^2 v'} &= S_{uuv} - 2S_u S_{uv} - S_v S_{uu} + 2S_v S_u S_u \\
 \overline{u'v'^2} &= S_{uvv} - 2S_v S_{uv} - S_u S_{vv} + 2S_u S_v S_v
 \end{aligned} \right\} \quad (17)$$

4. SAMPLE RESULTS FOR A PLANE MIXING LAYER

Selected results of measurements made in the near-field of a plane mixing layer are presented in figure 7. Figure 6 depicts the situation and needed reference quantities. The mixing-layer velocity ratio was about 2:1, with a maximum velocity of 21 m/sec. Results for both tripped and untripped initial boundary layers are presented in figure 7.

The profiles of mean velocity shown in figure 7(a) were fitted to the similarity coordinates for the developed mixing layer as recommended by, for example, Townsend (ref. 2). The fit results in a collapse of the mean profiles to the error function shape at successive streamwise locations, and the growth rate inferred from the resulting thickness parameter can be used to check the measured values of $\overline{u'v'}$ shown in figure 7(d). The actual values and trends of the turbulence quantities, such as those shown in figure 7(b-d), measured using the present system, compare extremely well with theory and data from other experiments. Full details of the measurements in plane mixing layers are given in reference 3.

5. CONCLUDING REMARKS

A system for rapid computerized acquisition and processing of analog signals from a hot-wire anemometer has been developed. Probe calibration is also implemented in the system. Correction for ambient temperature drift is implemented in the software. Complete calibration and acquisition for a typical 20-point profile requires less than 60 min.

Data acquired with this system in a plane mixing layer, including turbulence measurements up to third-order correlations, agree well with theory and existing data.

APPENDIX

SOFTWARE FOR THE HP9845B DESK-TOP COMPUTER

The HP9845B desk-top computer used included an I/O ROM and ran programs written in BASIC. Three programs are included: "UWIRE," a program for single hot-wire data acquisition and real-time data reduction; "XWIRE," for calibration, data acquisition, and storage of data using the crossed hot-wire CTA system; and "UVBAR," used to reduce the data from files written by the data acquisition program "XWIRE."

```

10  REM PROGRAM UWIRE
20  ! PROGRAM TO ACQUIRE SINGLE-WIRE DATA USING THE LDV-A/D CI
30  OPTION BASE 1
40  DIM Titl$(80),Ystr$(30) ! information strings for data file
50  INTEGER D1(3000,4) ! data buffer
60  INTEGER S(3000),C(2,3000),T(3000) ! words from CI
70  INTEGER Ns
80  INTEGER Zero,Eref,Off,Egain,Eoff,Ezero,E1a R1av
90  INTEGER Obts,Off1
100  INTEGER E1in(20)
110  INTEGER E0del,Edel(10)
120  INTEGER J,Jntr
130  INTEGER Ical,Ipt,Ncal
140  REAL Rgain,Gain
150  REAL V1(20),Ucal(20)
160  REAL N,K,Esq
170  REAL Uical,Tcal,Tnow,Ohr,Alpha
180  REAL Vhwb,Uest
190  REAL Ueff(4096) ! look-up table for Ueff calibration 12-bit A/D
200  REAL Yval(30)
210  SHORT Ueff12(3000) ! data array written to floppy
220  SHORT Ubar(30),Upri(30)
230  PRINT
240  PRINTER IS 0
250  PRINT "** << PROGRAM UWIRE : FULLY-DIGITAL U-WIRE DATA ACQUISITION >> **"
260  PRINT
270  PRINT " PROGRAM STRUCTURE : "
280  PRINT " 1. Calibrate the A/D converter of the LDV CI."
290  PRINT " 2. Calibrate the probe vs. velocity."
300  PRINT " 3. Construct look-up table."
310  PRINT " 4. Acquire data and write U to disk file."
320  PRINT " 5. Repeat (4.) for each data point taken."
330  PRINT " 6. Reduce data off-line with another program."
340  PRINT
350  !
360  ! ** Calibrate the A/D channel 1
370  !
380  PRINT
390  PRINT "** CALIBRATION OF THE A/D CONVERTER **"
400  PRINT
410  Ns=10 !10 samples are averaged at each point
420  Ical=1
430  GOSUB Adcal
440  Ezero=Zero
450  Eoff=Off
460  Gain=Rgain
470  !
480  ! ** Calibrate wire vs. velocity
490  !
500  ! 1. Compile raw calibration data table
510  PRINT
520  PRINT "** CALIBRATION TO DETERMINE Ebridge vs. Ueff **"
530  PRINT
540  INPUT "Enter calibration flow temperature in deg. F:",Tcal
550  Tcal=.5556*(Tcal-32)
560  INPUT "Enter wire temperature resistivity coefficient :",Alpha
570  INPUT "Enter nominal overheat ratio used (about 1.8) :",Ohr
580  ! NOTE: Wire parameters are needed to do temperature correction
590  PRINT "Kings Law will be used to construct the look-up table -"

```



```

600 PRINT "          U = K*(E^2-E0^2)**(1/N)"
610 PRINT "The constants K, E0^2, and N may be determined from direct"
620 PRINT "calibration or input directly. Enter C to calibrate, or I"
630 PRINT "to input the constants directly."
640 INPUT " (enter C or I) :",Cal$
650 IF Cal$="C" THEN GOTO 720
660 IF Cal$="I" THEN GOTO 680
670 GOTO 640
680 INPUT "Enter K : ",K
690 INPUT "  E0^2 : ",Esq
700 INPUT "    N : ",N
710 GOTO 960
720 INPUT "Enter no. points to be taken (<= 20 total) :",Ncal
730 Ns=100      !100 samples are to be taken at each point
740   FOR Ical=1 TO Ncal
750     PRINT "Point no. ";Ical
760     INPUT "Enter calibration velocity :",Ucal(Ical)
770     GOSUB Atod
780     Elin(Ical)=0      !compute average bridge output value
790     FOR Icpt=1 TO Ns
800       Elin(Ical)=Elin(Ical)+(C(1,Icpt)-Elin(Ical))/Icpt
810     NEXT Icpt
820     ! 2. Convert to volts
830     V1(Ical)=FNVbrg(Elin(Ical),Ezero,Eoff,Gain)
840     PRINT Ical;Ucal(Ical);V1(Ical)
850   NEXT Ical
860 PRINT "** CALIBRATION DATA ACQUISITION COMPLETE **"
870 PRINT
880 ! 3. Perform King's law fit
890 PRINT "Perform King's law fit --"
900 PRINT "Channel 1 : "
910 CALL Hwcal(Ncal,V1(*),Ucal(*),N,K,Esq)
920 PRINT
930 !
940 ! ** Construct look-up table to implement the calibration
950 !
960 PRINT
970 PRINT "** LOOK-UP TABLE CONSTRUCTION AND VERIFICATION **"
980 PRINT
990 ! The matrix Ueff is a look-up table of values of velocity
1000 ! from the King's Law fit versus the input value.
1010   FOR J=1 TO 4096
1020     Vhwb=FNVbrg(J,Ezero,Eoff,Gain)
1030     IF Vhwb^2>Esq THEN GOTO 1060
1040     Ueff(J)=0
1050     GOTO 1070
1060     Ueff(J)=FNKing(Vhwb,K,Esq,N)
1070   NEXT J
1080 IF Cal$="I" THEN GOTO 1240
1090 PRINT "Re-contruction of calibration data : "
1100 PRINT
1110 ! Verify look-up table by re-constructing calibration data
1120 !
1130 PRINT "PT.  Uactual  E1    U1CAL"
1140 PRINT "-----"
1150   FOR Icpt=1 TO Ncal
1160     Jntr=Elin(Icpt)
1170     U1cal=Ueff(Jntr)
1180     PRINT Icpt;Ucal(Icpt);Elin(Icpt);U1cal

```

```

1190     NEXT Icpt
1200 PRINT
1210 !
1220 ! ** Acquire and store data at successive points:
1230 !
1240 Isft1=0
1250 Tnow=Tcal
1260 PRINT "** DATA ACQUISITION **"
1270 PRINT
1280 PRINT "   Enter run parameters: "
1290 PRINT
1300 INPUT " - No. data samples per point (<3000) :",Ns
1310 REDIM Ueff12(Ns)
1320 PRINT "Enter response to determine type of data file to write:"
1330 PRINT "N - no data file written"
1340 PRINT "R - raw data written at each point"
1350 PRINT "S - only summary written at the end of the profile"
1360 INPUT "Enter N, R, or S :",Rfil#
1370 IF Rfil#="N" THEN GOTO 1400
1380 PRINT "Enter parent filename - for raw data file, the point number"
1390 PRINT "is appended to this name. This will be the name used for a"
1400 PRINT "summary data file."
1410 INPUT "Enter filename :",Name#
1420 INPUT " - Enter Y if temperature correction is desired :",Rtem#
1430 Ipt=1
1440 !   1. Move to next location (& enter flow temp if correcting)
1450 PRINT
1460 PRINT "POINT NUMBER : ";Ipt
1470 INPUT "Enter Y location :",Yval(Ipt)
1480 INPUT "Enter flow temperature in deg. F: ",Tnow
1490 Tnow=.5556*(Tnow-32)
1500 !   2. Obtain raw data
1510 GOSUB Atod
1520 !   3. Estimate average bridge output voltage (if temp correcting)
1530 E1av=0
1540   FOR I=1 TO 10
1550     E1av=E1av+(C(1,I)-E1av)/I
1560   NEXT I
1570 Uest=Ueff(E1av)
1580 V1av=FNVbrg(E1av,Ezero,Eoff,Gain)
1590 PRINT "Approx. R/D value = ";E1av;" =>";V1av;" Volts & U = ";Uest
1600 IF Rtem#<>"Y" THEN GOTO 1670
1610 R1av=Gain#Eoff+(E1av-Ezero)
1620 !   4. Compute shift to calibration for temperature drift
1630 Isft1=FNShift(Alpha,Ohn,Tcal,Tnow,R1av)
1640 Uest=Ueff(E1av+Isft1)
1650 Vest=FNVbrg(E1av+Isft1,Ezero,Eoff,Gain)
1660 PRINT "Shifted R/D value = ";E1av+Isft1;" =>";Vest;" Volts & U = ";Uest
1670 !   5. Implement look-up table
1680 Ubar(Ipt)=0
1690 Upri(Ipt)=0
1700   FOR J=1 TO Ns
1710     J1lt=C(1,J)+Isft1
1720     Ueff12(J)=Ueff(J1lt)
1730     Ubar(Ipt)=Ubar(Ipt)+(Ueff12(J)-Ubar(Ipt))/J
1740     Upri(Ipt)=Upri(Ipt)+(Ueff12(J)*Ueff12(J)-Upri(Ipt))/J
1750   NEXT J
1760 Upri(Ipt)=Upri(Ipt)-Ubar(Ipt)*Ubar(Ipt)
1770 Upri(Ipt)=SOR(Upri(Ipt))

```

```

1780 PRINT "Y= ";Yval(Ipt);"UBAR = ";Ubar(Ipt);"  UPRIME = ";Upri(Ipt)
1790 PRINT
1800 IF Afil#<>"R" THEN GOTO 1830
1810 !      6. Store data on floppy disk
1820 GOSUB Dfile
1830 PRINT
1840 INPUT "Enter Y to take another data point, else N : ",Ans#
1850 IF Ans#="N" THEN 1900
1860 IF Ans#<>"Y" THEN 1840
1870 Ipt=Ipt+1
1880 GOTO 1450
1890 !
1900 REDIM Ubar(Ipt)
1910 REDIM Upri(Ipt)
1920 REDIM Yval(Ipt)
1930 IF Afil#="S" THEN GOSUB Dfile
1940 PRINT "Enter one of the following to proceed:"
1950 PRINT "M - Take another profile with same calibrations"
1960 PRINT "R - Recalibrate"
1970 PRINT "E - Exit program"
1980 INPUT "Press M, R, or E :",Ans#
1990 IF Ans#="M" THEN GOTO 1200
2000 IF Ans#="R" THEN GOTO 380
2010 IF Ans#="E" THEN GOTO 2030
2020 GOTO 1980
2030 END
2040 ! !!!!!!!!!!!!!!!!!!!!!!!!!!!!!!!!!!!!!!!!!!!!!!!!!!!!!!!!!!!!!!!
2050 ! ***** END OF MAIN PROGRAM UWIRE *****
2060 ! !!!!!!!!!!!!!!!!!!!!!!!!!!!!!!!!!!!!!!!!!!!!!!!!!!!!!!!!!!!!!!!
2070 Dfile:      ! write data file to floppy
2080 PRINT
2090 PRINT "** DATA FILE WRITE TO FLOPPY DISK **"
2100 PRINT
2110 PRINT "At this point be sure there is a floppy in drive 0 of"
2120 PRINT "the 9895A with space for a file of 50, 256-byte records."
2130 DISP "**** Press CONT to proceed when ready ****"
2140 PAUSE
2150 DISP "**** File write in progress ****"
2160 File#=Name#
2170 IF Afil#="R" THEN File#=Name#&VAL$(Ipt)
2180 MASS STORAGE IS ":H0,0,0"      ! set floppy drive (9895A drive 0) as default
2190 CREATE File#,50                ! open file with 100 records 256 bytes each
2200 ASSIGN File# TO #1
2210 PRINT #1;Titl#
2220 IF Afil#="R" THEN PRINT #1;Yval(Ipt)
2230 PRINT #1;K,Esq,N
2240 PRINT #1;Tcal,Tnow,Alpha,Ohm
2250 PRINT #1;Isft1
2260 PRINT #1;Ns
2270 IF Afil#="S" THEN MAT PRINT #1;Yval
2280 IF Afil#="S" THEN MAT PRINT #1;Ubar
2290 IF Afil#="S" THEN MAT PRINT #1;Upri
2300 IF Afil#="R" THEN MAT PRINT #1;Ueff12
2310 ASSIGN * TO #1                ! close data file
2320 DISP "**** File write completed ****"
2330 RETURN
2340 ! !!!!!!!!!!!!!!!!!!!!!!!!!!!!!!!!!!!!!!!!!!!!!!!!!!!!!!!!!!!!!!!
2350 Adcal:      ! calibrate the A/D converter of the LDV CI
2360             ! enter the routine with Ichan and Ns set
2370 ! !!! This segment is for fixing the shorted-input value

```

```

2380 PRINT
2390 PRINT " *** Calibrate the A/D converter channel ";Ichan;" ***"
2400 DISP "Short input of channel ";Ichan;" then press CONT"
2410 PAUSE
2420 GOSUB Atod
2430 ! Average the 10 readings to get the zero value
2440 Zero=0
2450 FOR I=1 TO Ns
2460 Zero=Zero+C(Ichan,I)
2470 NEXT I
2480 Zero=Zero/Ns
2490 PRINT "Zero-level output is : ";Zero;" of 12 bits"
2500 ! !!! Now read the reference value
2510 PRINT "Now calibrate the GAIN=1 vs. DIRECT before proceeding"
2520 DISP "Connect REF voltage to chan ";Ichan;" then press CONT"
2530 PAUSE
2540 GOSUB Atod
2550 Eref=0
2560 FOR I=1 TO Ns
2570 Eref=Eref+(C(Ichan,I)-Eref)/I
2580 NEXT I
2590 PRINT "Reference voltage applied to channel";Ichan;" is ";Eref
2600 ! !!! Offset calibration
2610 DISP "Apply an OFFSET to channel ";Ichan;" then press CONT"
2620 PAUSE
2630 GOSUB Atod
2640 Off=0
2650 FOR I=1 TO Ns
2660 Off=Off+(C(Ichan,I)-Off)/I
2670 NEXT I
2680 Obts=Off
2690 Off1=Eref-Off
2700 PRINT "Offset value is : ";Off1
2710 ! !!! Set GAIN now
2720 DISP "Set GAIN on channel";Ichan;" then press CONT"
2730 PAUSE
2740 GOSUB Atod
2750 Egain=0
2760 FOR I=1 TO Ns
2770 Egain=Egain+(C(Ichan,I)-Egain)/I
2780 NEXT I
2790 Rgain=(Egain-Zero)/(Obts-Zero)
2800 PRINT "Gain is : ";Rgain
2810 ! !!! Reset OFFSET as desired
2820 DISP "Reset OFFSET on channel";Ichan;" then press CONT"
2830 PAUSE
2840 GOSUB Atod
2850 Off=0
2860 FOR I=1 TO Ns
2870 Off=Off+(C(Ichan,I)-Off)/I
2880 NEXT I
2890 Off=(Egain-Off)/Rgain+Off1
2900 PRINT "Final OFFSET value is : ";Off;" bits"
2910 RETURN
2920 ! !!!!!!!!!!!!!!!!!!!!!!!!!!!!!!!!!!!!!!!!!!!!!!!!!!!!!!!!!!!!!!!!!!!!!!!
2930 Atod: ! Subroutine for input from the LDV-A/D CI
2940 ! Enter routine with Ns=no. samples
2950 DISP "Press CONT to initiate data acquisition"
2960 PAUSE

```

```

2970 RESET 10
2980 CONTROL MASK 10;1
2990 WRITE IO 10,5;0
3000 WRITE IO 10,5;1 !start handshake by setting CTL0
3010 Nt=4*Ns
3020 FOR I=1 TO 3
3030 Dummy=READBIN(10)
3040 NEXT I
3050 REDIM D1(Ns,4)
3060 ENTER 10 WFHS Nt NOFORMAT;D1(*) !fast data acquisition
3070 FOR I=1 TO Ns
3080 C(1,I)=D1(I,3)+2048
3090 NEXT I
3100 DISP "Data acquisition complete"
3110 RETURN
3120 ! !!!!!!!!!!!!!!!!!!!!!!!!!!!!!!!!!!!!!!!!!!!!!!!!!!!!!!!!!!!!!!!!!!!!!!!
3130 SUB Hwcal(INTEGER Np,REAL E(*),REAL U(*),REAL N,REAL K,REAL Esq)
3140 ! Subprogram to compute hot-wire calibration constants for
3150 ! King's law calibration via linear least square fit
3160 OPTION BASE 1
3170 INPUT "Enter exponent N (approx. 0.45) : ",N
3180 L0=0 ! initialize sums for linear least-squares fit
3190 L2=0
3200 S2=0
3210 S4=0
3220 FOR I=1 TO Np
3230 L0=L0+U(I)^N
3240 L2=L2+E(I)^2*U(I)^N
3250 S2=S2+E(I)^2
3260 S4=S4+E(I)^4
3270 NEXT I
3280 D=S2*S2-Np*S4
3290 A=(L0*S2-Np*L2)/D
3300 B=(S2*L2-S4*L0)/D
3310 K=A^(1/N) ! scale factor
3320 Esq=-B/A ! effective no-flow bridge output squared
3330 PRINT "Scale factor : ";K
3340 PRINT "Ezero squared: ";Esq
3350 Err=0 ! compute RMS % error of the fit
3360 FOR I=1 TO Np
3370 Err=Err+((U(I)-K*(E(I)*E(I)-Esq)^(1/N))/U(I))^2
3380 NEXT I
3390 Err=100*SQR(Err/Np)
3400 PRINT "RMS percent error of the fit : ";Err;" %"
3410 SUBEND
3420 ! !!!!!!!!!!!!!!!!!!!!!!!!!!!!!!!!!!!!!!!!!!!!!!!!!!!!!!!!!!!!!!!!!!!!!!!
3430 DEF FNVbrg(INTEGER Ein,INTEGER Zero,INTEGER Off,REAL Gain)
3440 ! Compute the bridge output voltage based on calibration values
3450 RETURN ((Ein-Zero)/Gain+Off)*20/4096
3460 FNEND
3470 DEF FNYaw(REAL Del,REAL Ebr,REAL A,REAL N,REAL E0bns)
3480 ! !!!!!!!!!!!!!!!!!!!!!!!!!!!!!!!!!!!!!!!!!!!!!!!!!!!!!!!!!!!!!!!!!!!!!!!
3490 DEF FNKing(REAL Ebr,REAL K,REAL E0sq,REAL N)
3500 ! Compute velocity based on King's Law calibration constants
3510 RETURN K*(Ebr^2-E0sq)^(1/N)
3520 FNEND
3530 ! !!!!!!!!!!!!!!!!!!!!!!!!!!!!!!!!!!!!!!!!!!!!!!!!!!!!!!!!!!!!!!!!!!!!!!!
3540 DEF FNShift(REAL Alpha,REAL Dhr,REAL Tref,REAL T,INTEGER R)
3550 ! Compute temperature drift correction to bridge voltage

```

```
3560 Cpct=Alpha*(T-Tref)/(2*(Ohr-1)) ! % shift in bridge output voltage
3570 RETURN Cpct*R
3580 FNEND
3590 ! !!!!!!!!!!!!!!!!!!!!!!!!!!!!!!!!!!!!!!!!!!!!!!!!!!!!!!!!!!!!!!!!!!!!!!!
3600 DEF FNYaw(REAL De1,REAL Ebr,REAL A,REAL N,REAL E0brs)
3610 FNEND
```

```

10  REM PROGRAM XWIRE2
20  ! PROGRAM TO ACQUIRE X-WIRE DATA USING THE LDV-A/D CI
30  OPTION BASE 1
40  DIM Titl$(180),Ystr$(180) ! information strings for data file
50  INTEGER D1(3000,4) !data buffer
60  INTEGER C(2,3000) ! data words from CI
70  INTEGER Ns,Ichan
80  INTEGER Zero,Eref,Off,Egain,Eoff(2),Ezero(2)
90  INTEGER E1in(20),E2in(20)
100 INTEGER E0del(2),Edel(2,10)
110 INTEGER Jntr,J,Ncal,Ipt,Ical
120 INTEGER R1av,R2av
130 INTEGER Flag
140 REAL Ohr,Alpha,Tcal,Tnow
150 REAL Rgain,Gain(2)
160 REAL V1(20),V2(20),Ucal(20)
170 REAL N(2),Kstr(2),K(2),Esq(2),Ca(2),Ang(2)
180 REAL N2(2),K2str(2),K2(2),E2sq(2),C2a(2)
190 REAL V0del(2),Vdel(2),Del(10),T1a,T2a,U1cal,U2cal,T1a1,T2a1
200 PRINT
201 PRINTER IS 16
200 PRINT "** << PROGRAM XWIRE2 : FULLY-DIGITAL X-WIRE DATA ACQUISITION >> **"
230 PRINT
240 PRINT " PROGRAM STRUCTURE : "
250 PRINT " 1. Calibrate the A/D converter of the LDV CI."
260 PRINT " 2. Calibrate the X probe vs. velocity."
270 PRINT " 3. Yaw calibration of the X probe to determine wire angles."
280 PRINT " 4. Acquire data and write raw data from chs 1 & 2 to disk file."
290 PRINT " 5. Repeat (5.) for each data point taken."
300 PRINT " 6. Reduce data off-line with another program."
310 PRINT
320 !
330 ! ** Calibrate the A/D - both channels
340 !
341 PRINTER IS 0
350 PRINT
360 PRINT "** CALIBRATION OF THE A/D CONVERTER **"
370 PRINT
380 ! 1. Channel 1 is done first
390 Ns=10 !10 samples are averaged at each point
400 Ichan=1
410 GOSUB Adcal
420 Ezero(Ichan)=Zero
430 Eoff(Ichan)=Off
440 Gain(Ichan)=Rgain
450 ! 2. Channel 2 is calibrated next
460 Ichan=2
470 GOSUB Adcal
480 Ezero(Ichan)=Zero
490 Eoff(Ichan)=Off
500 Gain(Ichan)=Rgain
510 Acal#="N"
520 !
530 ! ** Calibrate both wires at fixed angle vs. velocity
540 !
550 ! 1. Compile raw calibration data table
560 PRINT
570 PRINT "** CALIBRATION TO DETERMINE Ebridge vs. Ueff **"
580 PRINT

```

```

590 INPUT "Enter calibration flow temperature in deg. F:" Tcal
600 Tcal=.5556*(Tcal-32)
610 INPUT "Enter wire temperature resistivity coefficient :",Alpha
620 INPUT "Enter nominal overheat ratio used (about 1.8) :",Ohr
630 ! NOTE: Wire parameters are needed to do temperature correction
631 PRINT " ALPHA = ";Alpha;" OHR = ";Ohr;" TCAL = ";Tcal;" C"
640 PRINT
650 INPUT "Enter no. points to be taken (<= 20 total) :",Ncal
660 Ns=100 !100 samples are to be taken at each point
670 FOR Ical=1 TO Ncal
680 DISP "Point no. ";Ical
690 INPUT "Enter the calibration velocity : ",Ucal(Ical)
700 GOSUB Atod
710 E1in(Ical)=0 !compute average bridge output value
720 E2in(Ical)=0
730 FOR Icpt=1 TO Ns
740 E1in(Ical)=E1in(Ical)+(C(1,Icpt)-E1in(Ical))/Icpt
750 E2in(Ical)=E2in(Ical)+(C(2,Icpt)-E2in(Ical))/Icpt
760 NEXT Icpt
770 ! 2. Convert to volts
780 V1(Ical)=FNVBrg(E1in(Ical),Ezero(1),Eoff(1),Gain(1))
790 V2(Ical)=FNVBrg(E2in(Ical),Ezero(2),Eoff(2),Gain(2))
800 PRINT "Point ";Ical;" U= ";Ucal(Ical);" V1= ";V1(Ical);" V2= ";V2(Ical)
810 NEXT Ical
820 PRINT "** CALIBRATION DATA ACQUISITION COMPLETE **"
830 PRINT
840 ! 3. Perform King's law fit
850 PRINT "Perform King's law fit for both channels --"
860 PRINT "The results will be a scale factor K* = K/COS(A) and"
870 PRINT "effective no-flow output E0^2. A is the effective wire"
880 PRINT "angle in the plane of the wire."
890 PRINT
900 PRINT "Channel 1 : "
910 Flag=0
920 IF Acal#="Y" THEN Flag=1 ! E0^2 is fixed for Acal#=1
930 CALL Hwcal(Ncal,V1(*),Ucal(*),N2(1),K2str(1),E2sq(1),Flag)
940 PRINT
950 PRINT "Channel 2 : "
960 CALL Hwcal(Ncal,V2(*),Ucal(*),N2(2),K2str(2),E2sq(2),Flag)
970 ! Kstr is K/COS(A), where A is the effective wire angle
980 ! which is determined in the next program segment
990 ! Note that the effective zero-flow voltage Esq is needed
1000 ! for the yaw calibration.
1010 IF Acal#="Y" THEN GOTO 1090
1020 !
1030 ! ** Yaw calibration to determine effective wire angles
1040 !
1050 PRINT
1060 PRINT "** YAW CALIBRATION - PROBE YAWED IN WIRE PLANE **"
1070 PRINT
1080 RAD
1090 Ns=100 !100 samples are used in yaw calibration
1100 ! 1. Fix the velocity and get data at delta=0
1110 PRINT "The nominal yaw angle is Delta - the effective wire"
1120 PRINT "angle in the wire plane is now determined by the"
1130 PRINT "yaw calibration."
1140 PRINT
1150 DISP "Set probe at Delta=0 then press CONT"
1160 PAUSE

```



```

1170 GOSUB Atod
1180 E0del(1)=0
1190 E0del(2)=0
1200 FOR Icpt=1 TO Ns
1210 E0del(1)=E0del(1)+(C(1,Icpt)-E0del(1))/Icpt
1220 E0del(2)=E0del(2)+(C(2,Icpt)-E0del(2))/Icpt
1230 NEXT Icpt
1240 V0del(1)=FNvbrg(E0del(1),Ezero(1),Eoff(1),Gain(1))
1250 V0del(2)=FNvbrg(E0del(2),Ezero(2),Eoff(2),Gain(2))
1260 V0del(1)=V0del(1)^2
1270 V0del(2)=V0del(2)^2
1271 PRINT
1280 PRINT "Zero values : ch.1 : ";V0del(1);" ch. 2 : ";V0del(2);" volts2"
1290 PRINT
1300 ! 2. Yaw the probe through a series of angles
1310 Nyaw=1
1320 PRINT "Now the probe will be yawed through a series of angles"
1330 PRINT "after which the average effective wire angle is computed."
1340 PRINT
1350 PRINT " - Point no. ";Nyaw
1360 INPUT "Enter the wire angle Delta :",Del(Nyaw)
1370 GOSUB Atod
1380 Edel(1,Nyaw)=0
1390 Edel(2,Nyaw)=0
1400 FOR Icpt=1 TO Ns
1410 Edel(1,Nyaw)=Edel(1,Nyaw)+(C(1,Icpt)-Edel(1,Nyaw))/Icpt
1420 Edel(2,Nyaw)=Edel(2,Nyaw)+(C(2,Icpt)-Edel(2,Nyaw))/Icpt
1430 NEXT Icpt
1440 INPUT "Reply Y to do another point, else N ? ",R#
1450 IF R#="N" THEN GOTO 1490
1460 Nyaw=Nyaw+1
1470 GOTO 1350
1480 ! 3. Compute tangent of average effective wire angle
1490 PRINT
1500 PRINT "YAW CALIBRATION DATA SUMMARY"
1510 PRINT "PT. YAW ANGLE TAN(A1) TAN(A2)"
1520 PRINT "-----"
1530 T1a=0
1540 T2a=0
1550 FOR Icpt=1 TO Nyaw
1560 Vdel(1)=FNvbrg(Edel(1,Icpt),Ezero(1),Eoff(1),Gain(1))
1570 Vdel(2)=FNvbrg(Edel(2,Icpt),Ezero(2),Eoff(2),Gain(2))
1580 ! NOTE: The effective wire angle is computed at each point-
1590 T1a1=FNYaw(Del(Icpt),Vdel(1),E2sq(1),N2(1),V0del(1))
1600 T1a=T1a+(T1a1-T1a)/Icpt
1610 T2a1=FNYaw(Del(Icpt),Vdel(2),E2sq(2),N2(2),V0del(2))
1620 T2a=T2a+(T2a1-T2a)/Icpt
1630 PRINT Icpt;" ";Del(Icpt);" ";T1a1;" ";T2a1
1640 NEXT Icpt
1650 PRINT
1660 PRINT "Averaged values: Tan psi1 = ";T1a;" Tan psi2 = ";T2a
1670 PRINT
1680 INPUT "Reply C to change these, else N : ",Ans#
1690 IF Ans#<>"C" THEN GOTO 1720
1700 INPUT "Enter Tan psi1, Tan psi2 :",T1a,T2a
1710 PRINT
1720 C2a(1)=1/SQR(1+ABS(T1a)^2) !remove effective wire angle
1730 K2(1)=K2str(1)*C2a(1) !from calibration constants
1740 C2a(2)=1/SQR(1+ABS(T2a)^2) !for constructing look-up table

```

```

1750     K2(2)=K2str(2)*C2a(2)
1760     PRINT
1790     INPUT "Y to perform orth. cal. in plane of measurement (reply Y or N) : "
,Acal$
1800     FOR I=1 TO 2
1810     K(I)=K2(I)
1820     N(I)=N2(I)
1830     Esq(I)=E2sq(I)
1840     Ca(I)=C2a(I)
1850     NEXT I
1860     IF Acal$="Y" THEN GOTO 640
1870     GOTO 1991
1880 ! 4. Effective wire angle in orthogonal plane is computed
1890 Ca(1)=K(1)/K2str(1)
1900 Ca(2)=K(2)/K2str(2)
1910 PRINT
1920 PRINT "Calibration constants used in look-up table construction:"
1930 PRINT " K1 = ";K(1);" K2 = ";K(2)
1940 PRINT " R1 = ";Esq(1);" R2 = ";Esq(2)
1950 PRINT " N1 = ";N(1);" N2 = ";N(2)
1960 PRINT " COS 1 = ";Ca(1);" COS 2 = ";Ca(2)
1970 Ang(1)=180*ACS(Ca(1))/PI
1980 Ang(2)=180*ACS(Ca(2))/PI
1990 PRINT " WIRE ANGLES : 1 = ";Ang(1);" 2 = ";Ang(2)
1991 PRINTER IS 16
1992 PRINT "** CRT is now the default printer **"
2000 !
2010 ! ** Acquire and store data at successive points:
2020 !
2030 Isft1=0
2040 Isft2=0
2050 Tnow=Tcal
2060 PRINT "** DATA ACQUISITION **"
2070 PRINT
2080 PRINT "   Enter run parameters: "
2090 PRINT
2100 PRINT " - Enter file name for output data files - not to exceed"
2110 PRINT "   4 characters - e.g. DATA. "
2120 INPUT "   Enter file name : ",Name$
2130 INPUT " - Enter a 1-line file title for the profile :",Titl$
2140 INPUT " - No. data samples per point (<3000) :",Ns
2150 INPUT " - Enter Y if temperature correction is desired :",Atem$
2160 Ipt=1
2170 !   1. Move to next location (& enter flow temp if connecting)
2180 PRINT
2190 PRINT "POINT NUMBER : ";Ipt
2200 INPUT "Enter flow temperature in deg. F: ",Tnow
2210 Tnow=.5556*(Tnow-32)
2220 INPUT "Enter one-line string to identify the current point :",Ystr$
2230 !   2. Obtain raw data
2240 GOSUB Atod
2250 !   3. Estimate average bridge output voltage (if temp connecting)
2260 IF Atem$<>"Y" THEN GOTO 2390
2270 E1av=0
2280 E2av=0
2290 FOR I=1 TO 10
2300 E1av=E1av+(C(1,I)-E1av)/I
2310 E2av=E2av+(C(2,I)-E2av)/I
2320 NEXT I

```

```

2330 R1av=Gain(1)*Eoff(1)+(E1av-Ezero(1))
2340 R2av=Gain(2)*Eoff(2)+(E2av-Ezero(2))
2350 ! 4. Compute shift to calibration for temperature drift
2360 Isft1=FNShift(Alpha,Ohn,Tcal,Tnow,R1av)
2370 Isft2=FNShift(Alpha,Ohn,Tcal,Tnow,R2av)
2380 ! 5. Store data on floppy disk
2390 GOSUB Dfile
2400 PRINT
2410 PRINT "Enter one of the following to proceed : "
2420 PRINT "E - exit the program"
2430 PRINT "P - another data point, same profile name"
2440 PRINT "N - new profile, same calibration"
2450 PRINT "C - new profile, repeat calibration procedure"
2460 INPUT "Enter E, P, N, or C : ",Ans$
2470 IF Ans$="E" THEN GOTO 2550
2480 IF Ans$="P" THEN GOTO 2520
2490 IF Ans$="N" THEN GOTO 2030
2500 IF Ans$="C" THEN GOTO 350
2510 GOTO 2460
2520 Ipt=Ipt+1
2530 GOTO 2180
2540 !
2550 END
2560 ! !!!!!!!!!!!!!!!!!!!!!!!!!!!!!!!!!!!!!!!!!!!!!!!!!!!!!!!!!!!!!!!
2570 ! ***** END OF MAIN PROGRAM XWIRE *****
2580 ! !!!!!!!!!!!!!!!!!!!!!!!!!!!!!!!!!!!!!!!!!!!!!!!!!!!!!!!!!!!!!!!
2590 Dfile: ! write raw X-wire data to a floppy file for later
2600 ! reduction (each raw A/D pair is stored)
2610 PRINT
2620 PRINT "** WRITE RAW DATA FILE **"
2630 PRINT
2640 PRINT "At this point be sure there is a floppy in drive 0 of"
2650 PRINT "the 9895A with space for a file of 100 records of 256"
2660 PRINT "bytes each. Press CONT when ready to proceed : "
2680 File$=Name$&VAL$(Ipt)
2690 PRINT "File ";File$;" being written "
2700 MASS STORAGE IS ":H8,0,0" ! 9895A floppy drive set as default
2710 CREATE File$,100 ! file is 100 records of 256 bytes
2720 ASSIGN File$ TO #1
2730 PRINT #1;Titl$
2740 PRINT #1;Ystr$
2750 PRINT #1;Tcal,Tnow,Alpha,Ohn
2760 PRINT #1;Eoff(1),Ezero(1),Gain(1) ! A/D cal constants
2770 PRINT #1;Eoff(2),Ezero(2),Gain(2)
2780 PRINT #1;K(1),Esq(1),N(1),Ca(1) ! cal constants for hot-wire
2790 PRINT #1;K(2),Esq(2),N(2),Ca(2)
2800 PRINT #1;Isft1,Isft2
2810 PRINT #1;Ns
2820 MAT PRINT #1;C ! Raw data for both wires
2830 ASSIGN * TO #1
2840 MASS STORAGE IS ":T15" ! reset tape drive as mass storage
2850 PRINT "** FILE WRITE COMPLETE **"
2860 RETURN
2870 ! !!!!!!!!!!!!!!!!!!!!!!!!!!!!!!!!!!!!!!!!!!!!!!!!!!!!!!!!!!!!!!!
2880 Adcal: ! calibrate the A/D converter of the LDV CI
2890 ! enter the routine with Ichan and Ns set
2900 ! !!! This segment is for fixing the shorted-input value
2910 PRINT
2920 PRINT " *** Calibrate the A/D converter channel ";Ichan;" ***"

```

```

2930 DISP "Short input of channel ";Ichan;" then press CON."
2940 PAUSE
2950   GOSUB Atod
2960   ! Average the 10 readings to get the zero value
2970   Zero=0
2980   FOR I=1 TO Ns
2990   Zero=Zero+(C(Ichan,I)-Zero)/I
3000   NEXT I
3010 PRINT "Zero-level output is : ";Zero;" of 12 bits"
3020   ! !!! Now read the reference value
3030 DISP "Connect ref voltage to chan ";Ichan;" then press CONT"
3040 PAUSE
3050   GOSUB Atod
3060   Eref=0
3070   FOR I=1 TO Ns
3080   Eref=Eref+(C(Ichan,I)-Eref)/I
3090   NEXT I
3100 PRINT "Reference voltage applied to channel";Ichan;" is ";Eref
3110   ! !!! An offset is applied and calibrated for channel Ichan
3120 DISP "Apply an offset to channel ";Ichan;" then press CONT"
3130 PAUSE
3140   GOSUB Atod
3150   Off=0
3160   FOR I=1 TO Ns
3170   Off=Off+(C(Ichan,I)-Off)/I
3180   NEXT I
3190 Off1=Eref-Off
3200 PRINT "Offset value is : ";Off1
3210   ! !!! A gain is calibrated - nominal values are set externally
3220 DISP "Set GAIN on channel ";Ichan;" then press CONT"
3230 PAUSE
3240   GOSUB Atod
3250   Egain=0
3260   FOR I=1 TO Ns
3270   Egain=Egain+(C(Ichan,I)-Egain)/I
3280   NEXT I
3290 Rgain=(Egain-Zero)/(Eref-Zero-Off1)
3300 PRINT "Gain of channel ";Ichan;" is ";Rgain
3310   ! !!! Reset the OFFSET value
3320 DISP "Reset the OFFSET on channel ";Ichan;" then press CONT"
3330 PAUSE
3340   GOSUB Atod
3350   Off=0
3360   FOR I=1 TO Ns
3370   Off=Off+(C(Ichan,I)-Off)/I
3380   NEXT I
3390 Off=(Egain-Off)/Rgain+Off1
3400 PRINT "Final OFFSET is :";Off;" bits"
3410 RETURN
3420 ! !!!!!!!!!!!!!!!!!!!!!!!!!!!!!!!!!!!!!!!!!!!!!!!!!!!!!!!!!!!!!!!!!!!!!!!
3430 Atod: ! Subroutine for input from the LDV-R/D CI
3440   ! Enter routine with Ns=no. samples
3450 DISP "Press CONT to initiate data acquisition"
3460 PAUSE
3470 RESET 10
3480 CONTROL MASK 10;1
3490 WRITE IO 10,5;0
3500 WRITE IO 10,5;1 !start handshake by setting CTL0
3510 Nt=4*Ns

```

```

3520   FOR I=1 TO 3
3530   Dummy=READBIN(10)
3540   NEXT I
3550   REDIM D1(Ns,4)
3560   !
3570   ENTER 10 WFHS Nt NOFORMAT;D1(*) !fast data acquisition
3580   DISP "Data acquisition complete"
3590   FOR I=1 TO Ns      !transfer the data to integer arrays
3600   C(1,I)=D1(I,3)+2048      !two data words (LDV is sending 4 words total
3610   C(2,I)=D1(I,4)+2048      !second data word
3620   NEXT I
3630   RETURN
3640   ! !!!!!!!!!!!!!!!!!!!!!!!!!!!!!!!!!!!!!!!!!!!!!!!!!!!!!!!!!!!!!!!!!!!!!!!
3650   SUB Hwcal(INTEGER Np,REAL E(*),REAL U(*),REAL N,REAL K,REAL Esq,INTEGER F1)
3660   ! Subprogram to compute hot-wire calibration constants for
3670   ! King's law calibration via linear least square fit
3680   OPTION BASE 1
3690   INPUT "Enter exponent N (approx. 0.45) : ",N
3700   IF F1=1 THEN GOTO 3870
3710   L0=0          ! initialize sums for linear least-squares fit
3720   L2=0
3730   S2=0
3740   S4=0
3750   FOR I=1 TO Np
3760   L0=L0+U(I)^N
3770   L2=L2+E(I)^2*U(I)^N
3780   S2=S2+E(I)^2
3790   S4=S4+E(I)^4
3800   NEXT I
3810   D=S2*S2-Np*S4
3820   A=(L0*S2-Np*L2)/D
3830   B=(S2*L2-S4*L0)/D
3840   K=A^(1/N)          ! scale factor
3850   Esq=-B/A          ! effective no-flow bridge output squared
3860   GOTO 3940
3870   L0=0
3880   L1=0
3890   FOR I=1 TO Np
3900   L0=L0+U(I)*((E(I)^2-Esq)^(1/N))
3910   L1=L1+((E(I)^2-Esq)^(2/N))
3920   NEXT I
3930   K=L0/L1
3940   PRINT "Scale factor K* : ";K
3950   PRINT "Ezero squared E0^2 : ";Esq
3960   Err=0          ! compute RMS % error of the fit
3970   FOR I=1 TO Np
3980   Err=Err+((U(I)-K*(E(I)*E(I)-Esq)^(1/N))/U(I))^2
3990   NEXT I
4000   Err=100*SQR(Err/Np)
4010   PRINT "RMS percent error of the fit : ";Err;" %"
4020   SUBEND
4030   ! !!!!!!!!!!!!!!!!!!!!!!!!!!!!!!!!!!!!!!!!!!!!!!!!!!!!!!!!!!!!!!!!!!!!!!!
4040   DEF FNVbrg(INTEGER Ein,INTEGER Zero,INTEGER Off,REAL Gain)
4050   ! Compute the bridge output voltage based on calibration values
4060   RETURN ((Ein-Zero)/Gain+Off)*20/4096
4070   FNEND
4080   ! !!!!!!!!!!!!!!!!!!!!!!!!!!!!!!!!!!!!!!!!!!!!!!!!!!!!!!!!!!!!!!!!!!!!!!!
4090   DEF FNYaw(REAL Del,REAL Ebr,REAL A,REAL N,REAL E0brs)
4100   ! Compute the effective wire angle given the nominal angle (Del) and

```

```

4110 ! appropriate constants from calibration vs. velocity
4120 Ang=Del*PI/180
4130 RETURN (COS(Ang)-((Ebr^2-R)/(E0brs-R))^(1/N))/SIN(Ang)
4140 FNEND
4150 ! !!!!!!!!!!!!!!!!!!!!!!!!!!!!!!!!!!!!!!!!!!!!!!!!!!!!!!!!!!!!!!!!!!!!!
4160 DEF FNKing(REAL Ebr,REAL K,REAL E0sq,REAL N)
4170 ! Compute velocity based on King's Law calibration constants
4180 RETURN K*(Ebr^2-E0sq)^(1/N)
4190 FNEND
4200 ! !!!!!!!!!!!!!!!!!!!!!!!!!!!!!!!!!!!!!!!!!!!!!!!!!!!!!!!!!!!!!!!!!!!!!
4210 DEF FNShift(REAL Alpha,REAL Ohr,REAL Tref,REAL T,INTEGER R)
4220 ! Compute temperature drift correction to bridge voltage
4230 Cpct=Alpha*(T-Tref)/(2*(Ohr-1)) ! % shift in bridge output voltage
4240 RETURN Cpct*R
4250 FNEND

```

```

10  REM PROGRAM UVBAR2
20  ! PROGRAM TO REDUCE X-WIRE DATA ACQUIRED WITH PROGRAM XWIRE2
30  ! Input is 2 channels of raw data and calibration constants
40  ! Output is the two components of mean velocity in the wire
50  ! plane as well as the in-plane turbulence stresses and third
60  ! order products.
70  OPTION BASE 1
80  DIM Titl#[80],Ystr#[80]
90  INTEGER Ns,Nf,Filno
100  INTEGER Eoff(2),Ezero(2)
110  INTEGER Isft1,Isft2
120  INTEGER C(2,3000)
130  INTEGER I,J,Jntr
140  REAL Vhwb
150  REAL Gain(2)
160  REAL Tcal,Tnow,Alpha,Ohr
170  REAL K(2),Esq(2),N(2),Ca(2)
180  REAL C1a,C2a
190  REAL Ueff(2,5000)
200  SHORT Ueff12(3000,2)
210  PRINT
220  PRINT " ** PROGRAM UVBAR2 - REDUCES RAW X-WIRE DATA **"
230  PRINT
240  PRINT "Program outline:"
250  PRINT "1. Read calibration and raw data from specified file."
260  PRINT "2. Construct look-up table and implement calibration."
270  PRINT "3. Compute running sums for statistics up to third order."
280  PRINT "4. Print results."
290  PRINT "NOTE: Channel 1 is assumed to be U+V wire for sign convention."
300  PRINTER IS 0
310  MASS STORAGE IS ":H8,0,0"
320  Filno=0
330  INPUT "Enter parent filename (or E to exit program) :",Name#
340  File#=Name#
350  IF File#="E" THEN GOTO 1310
360  INPUT "Enter no. of data files with parent prefix (0 if parent only)",Nf
370  IF Nf=0 THEN GOTO 410
380  Filno=Filno+1
390  IF Filno>Nf THEN GOTO 1290
400  File#=Name#&VAL$(Filno)
410  ASSIGN File# TO #1
420  READ #1;Titl#
430  PRINT Titl#
440  READ #1;Ystr#
450  PRINT Ystr#
460  READ #1;Tcal,Tnow,Alpha,Ohr
470  READ #1;Eoff(1),Ezero(1),Gain(1)
480  READ #1;Eoff(2),Ezero(2),Gain(2)
490  READ #1;K(1),Esq(1),N(1),Ca(1)
500  READ #1;K(2),Esq(2),N(2),Ca(2)
510  READ #1;Isft1,Isft2
520  READ #1;Ns
530  MAT READ #1;C
540  ! now reduce the data - three steps:
550  ! 1. Construct & implement look-up table
560  ! 2. Convert Ueff1,2 to U and V
570  ! 3. Update running sums
580  IF Filno>1 THEN GOTO 721
590  !

```

```

600 ! 1. Construct & implement look-up table
610 !
620   FOR J=1 TO 5000
630     FOR I=1 TO 2
640       Vhwb=FNvbrg(J,Ezero(I),Eoff(I),Gain(I))
650       IF Vhwb^2>Esq(I) THEN GOTO 680
660       Ueff(I,J)=0
670       GOTO 690
680       Ueff(I,J)=FNKing(Vhwb,K(I),Esq(I),N(I))
690     NEXT I
700   NEXT J
710   DISP "LOOK-UP TABLE CONSTRUCTION COMPLETED"
720 ! Implement look-up
721   Nout1=0
722   Nout2=0
730   FOR J=1 TO Ns
740     Jntr=C(1,J)+Isft1
741     IF C(1,J)<4095 THEN GOTO 750
743     Nout1=Nout1+1
750     Ueff12(J,1)=Ueff(1,Jntr)
760     Jntr=C(2,J)+Isft2
761     IF C(2,J)<4095 THEN GOTO 770
763     Nout2=Nout2+1
770     Ueff12(J,2)=Ueff(2,Jntr)
780   NEXT J
790   DISP "CALIBRATION IMPLEMENTATION COMPLETED"
800 !
810 ! 2. Convert Ueff 1,2 to U and V
820 !
830   Sin1=SQR(1-Ca(1)^2)
840   Sin2=SQR(1-Ca(2)^2)
850   D=Ca(1)*Sin2+Ca(2)*Sin1
860   A1=Sin2/D !channel 1 is U+V wire
870   A2=Sin1/D
880   A3=Ca(2)/D !channel 2 is U-V wire
890   A4=-Ca(1)/D
900   Su1=0
910   Sv1=0
920   Su2=0
930   Sv2=0
940   Suv=0
950   Su2v=0
960   Sv2u=0
970   FOR Ipt=1 TO Ns
980     U=A1*Ueff12(Ipt,1)+A2*Ueff12(Ipt,2)
990     V=A3*Ueff12(Ipt,1)+A4*Ueff12(Ipt,2)
1000 !
1010 ! 3. Running sums for statistics
1020 !
1030   Su1=Su1+(U-Su1)/Ipt
1040   Su2=Su2+(U^2-Su2)/Ipt
1050   Sv1=Sv1+(V-Sv1)/Ipt
1060   Sv2=Sv2+(V^2-Sv2)/Ipt
1070   Suv=Suv+(U*V-Suv)/Ipt
1080   Su2v=Su2v+(U*U*V-Su2v)/Ipt
1090   Sv2u=Sv2u+(U*V*V-Sv2u)/Ipt
1100   NEXT Ipt
1110   Ubar=Su1
1120   Vbar=Sv1

```



```

1130 Upri2=Su2-Su1*Su1
1140 Vpri2=Su2-Su1*Su1
1150 Uvbar=SuV-Su1*Su1
1160 U2vbar=Su2v-2*Ubar*SuV-Vbar*Su2+2*Ubar*Ubar*Vbar
1170 V2ubar=Su2u-2*Vbar*SuV-Ubar*Su2+2*Vbar*Vbar*Ubar
1180 PRINT
1190 PRINT "REDUCED DATA : Channel 1 taken as U+V "
1191 PRINT
1192 PRINT "Out-of-range data: chn 1 ";Nout1;" chn 2 ";Nout2
1193 PRINT "Total sample size: ";Ns
1200 PRINT "UBAR = ";Ubar;" VBAR = ";Vbar;" UNITS: L/T"
1220 PRINT "UPRI2 = ";Upri2;" VPRI2 = ";Vpri2;" UNITS: (L/T)^2"
1240 PRINT "UVBAR = ";Uvbar;" UNITS: (L/T)^2"
1260 PRINT "U2VBAR = ";U2vbar;" V2UBAR = ";V2ubar;" UNITS: (L/T)^3"
1270 PRINT
1280 GOTO 380
1290 INPUT "Reply Y to reduce another profile, else N :",Ans#
1300 IF Ans#="Y" THEN 310
1310 MASS STORAGE IS ":T15"
1320 PRINTER IS 16
1330 END
1340 ! !!!!!!!!!!!!!!!!!!!!!!!!!!!!!!!!!!!!!!!!!!!!!!!!!!!!!!!!!!!!!!!!!!!!!!!!!!!!!!!
1350 ! !!!!!!!!!!!!! END PROGRAM UVBAR2 !!!!!!!!!!!!!!!!!!!!!!!!!!!!!!!!!!!!!!!!!!!!!!!
1360 ! !!!!!!!!!!!!!!!!!!!!!!!!!!!!!!!!!!!!!!!!!!!!!!!!!!!!!!!!!!!!!!!!!!!!!!!!!!!!!!!
1370 DEF FNKing(REAL Ebr,REAL K,REAL E0sq,REAL N)
1380 ! compute velocity based on King's Law calibration
1390 RETURN K*(Ebr^2-E0sq)^(1/N)
1400 FNEND
1410 ! !!!!!!!!!!!!!!!!!!!!!!!!!!!!!!!!!!!!!!!!!!!!!!!!!!!!!!!!!!!!!!!!!!!!!!!!!!!!!!!
1420 DEF FNvbrg(INTEGER Ein,INTEGER Zero,INTEGER Off,REAL Gain)
1430 RETURN ((Ein-Zero)/Gain+Off)*20/4096
1440 FNEND
1450 ! !!!!!!!!!!!!!!!!!!!!!!!!!!!!!!!!!!!!!!!!!!!!!!!!!!!!!!!!!!!!!!!!!!!!!!!!!!!!!!!

```

REFERENCES

1. Operator's Manual for NASA 3-D LDV Computer Interface.
2. Townsend, A. A.: The Structure of Turbulent Shear Flow. Second ed., Cambridge University Press, 1976.
3. Mehta, R. D.; and Westphal, R. V.: Near-Field Turbulence Properties of Single and Two-Stream Plane Mixing Layers. AIAA Paper 84-0426, to be presented at the AIAA 22nd Aerospace Sciences Meeting, Reno, Nev., Jan. 9-12, 1984.

X-WIRE EQUIPMENT LIST

| ITEM NO. | MFG & MODEL | DESCRIPTION |
|----------|-----------------------------|--|
| 1 | NASA DESIGN (DISA 55P11) | MINIATURE X-WIRE WITH $5\mu\text{m}$ TUNGSTEN WIRES SINGLE MINIATURE HOT-WIRE WITH $5\mu\text{m}$ Pt-W SENSOR |
| 2 | DISA 55M10 | CONSTANT-TEMPERATURE BRIDGE |
| 3 | DISA 55D31 | DIGITAL VOLTMETER (AVERAGING) |
| 4 | DISA 55D26 | SIGNAL CONDITIONER |
| 5 | TEKTRONIX SC503 | 10 MHz STORAGE OSCILLOSCOPE (2 CHANNEL) |
| 6 | TEKTRONIX PG508 | 50 MHz PULSE GENERATOR |
| 7 | NASA DESIGN | LDV/A-D MUX AND 4-CHANNEL A-D WITH FAST SAMPLE-AND-HOLD |
| 8 | HP98032A | HIGH-SPEED 16-BIT PARALLEL INTERFACE |
| 9 | HP9845B | DESKTOP COMPUTER WITH I/O ROM INSTALLED |
| 10 | HP9895A | FLOPPY DISK DRIVE |

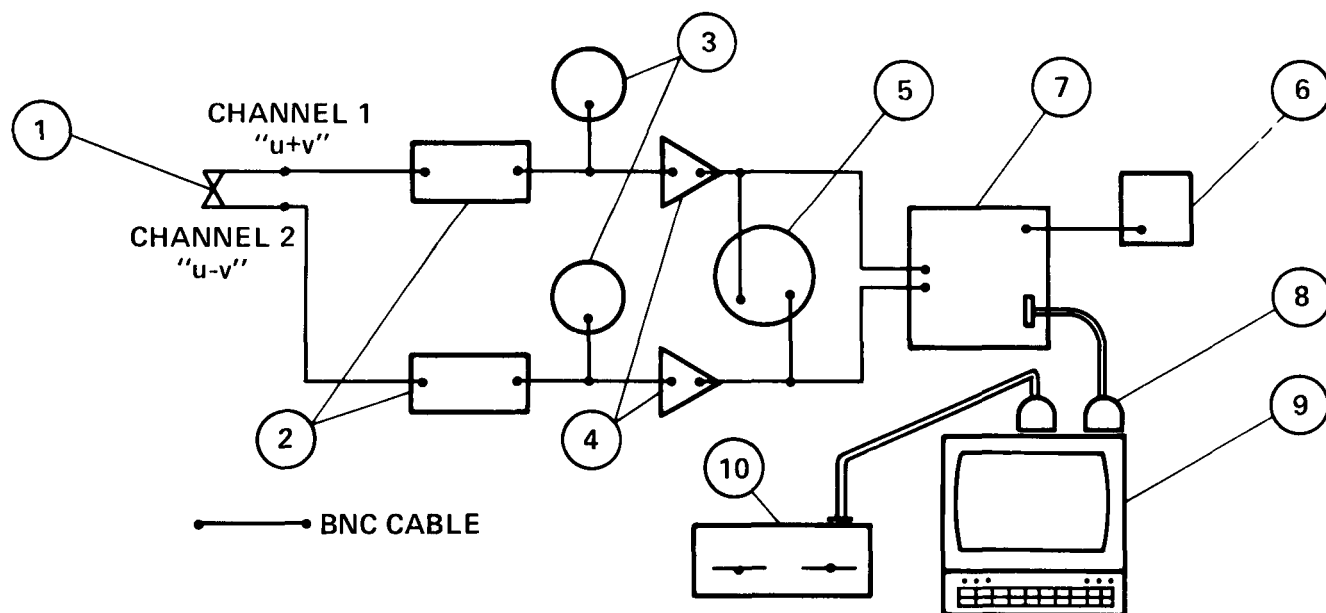

Figure 1.- Crossed-wire system hardware schematic.

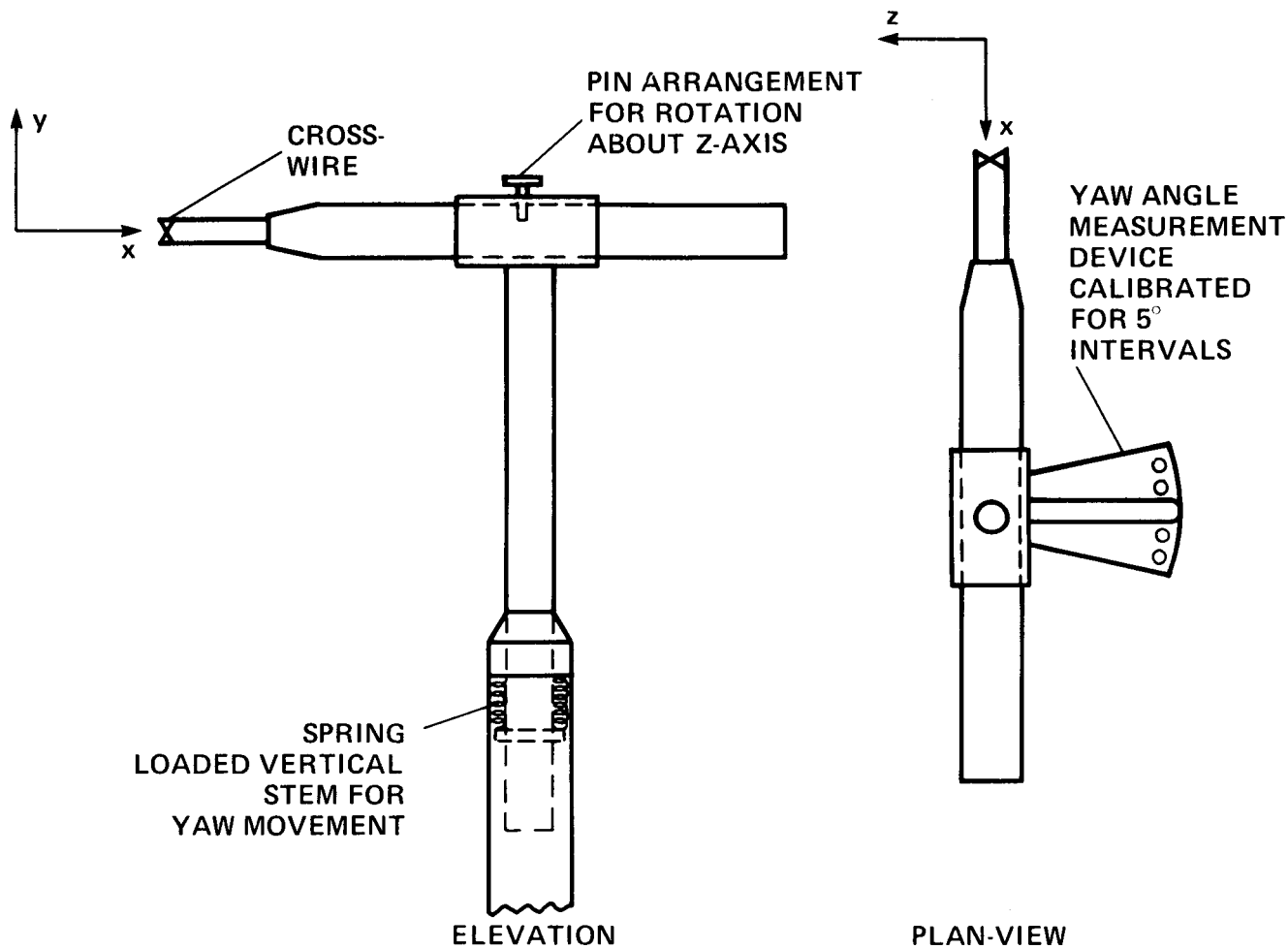

Figure 2.- NASA crossed-wire probe and holder.

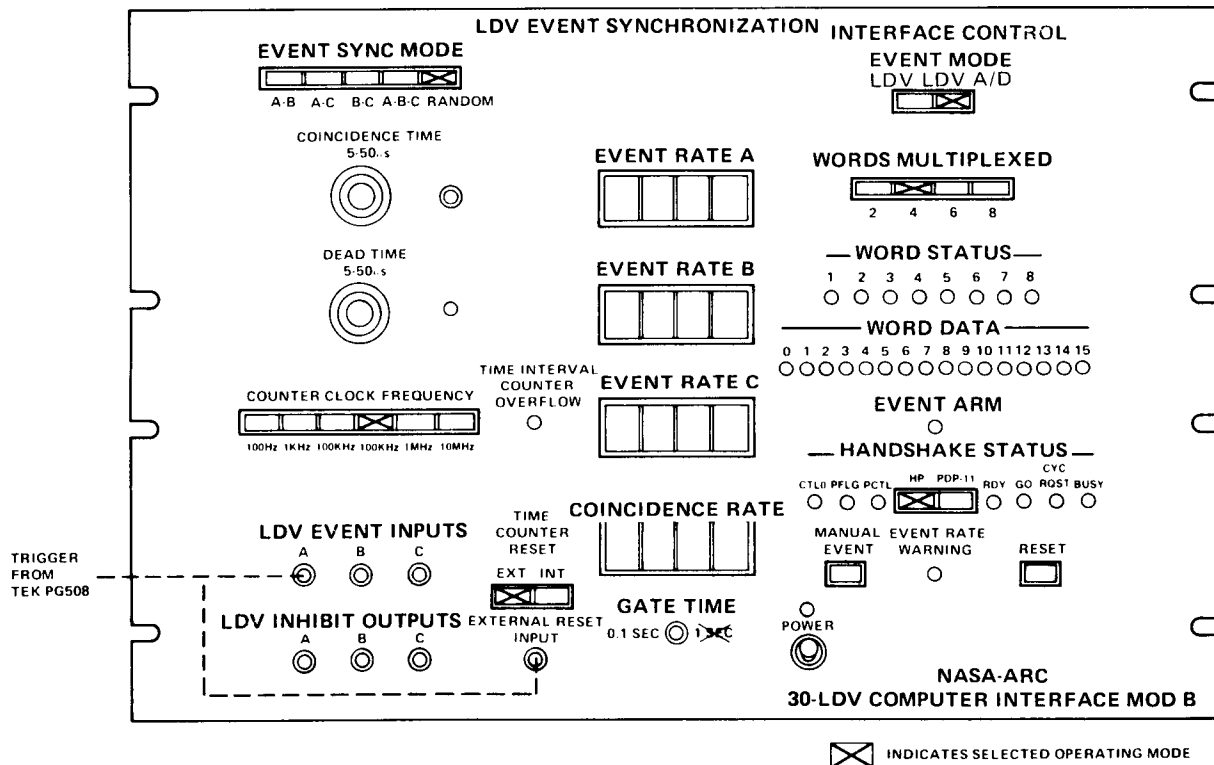
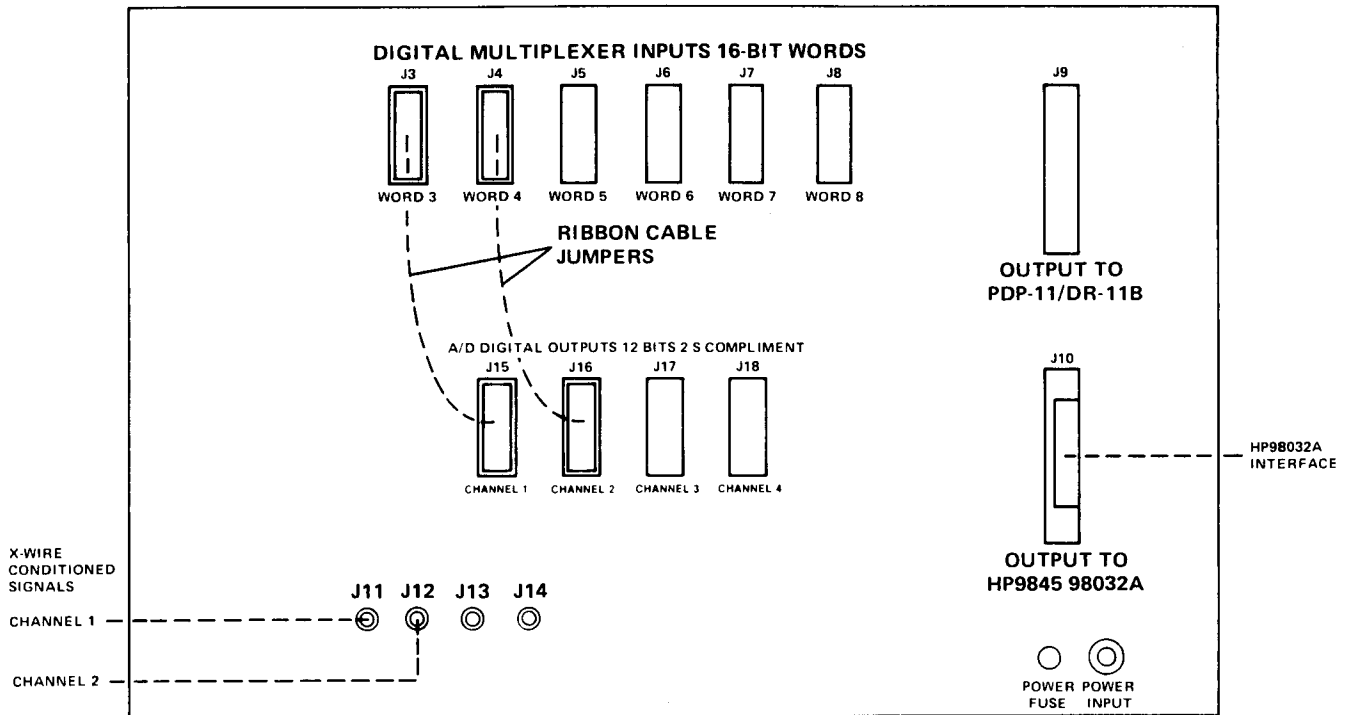

Figure 3.- NASA LDV-A/D computer interface connections.

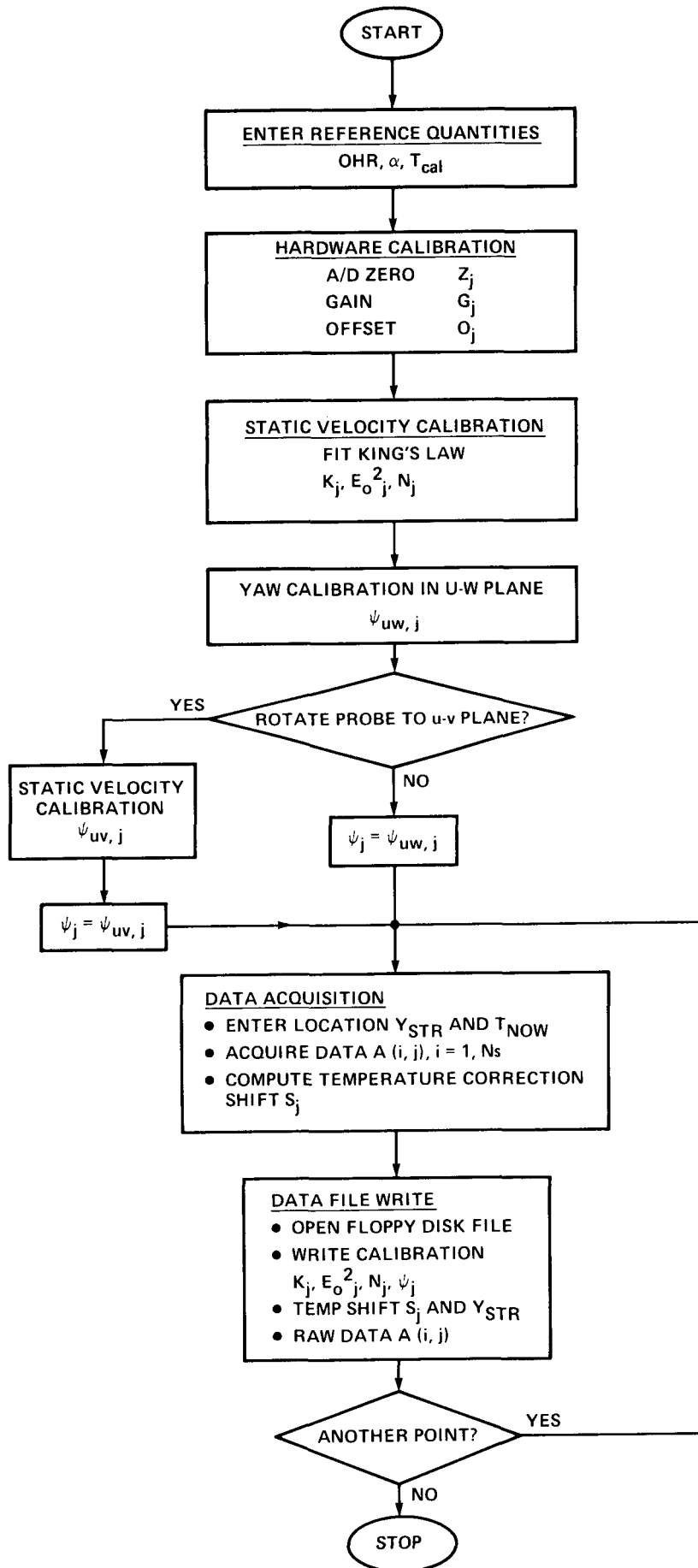

Figure 4.- Calibration and data-acquisition procedure.

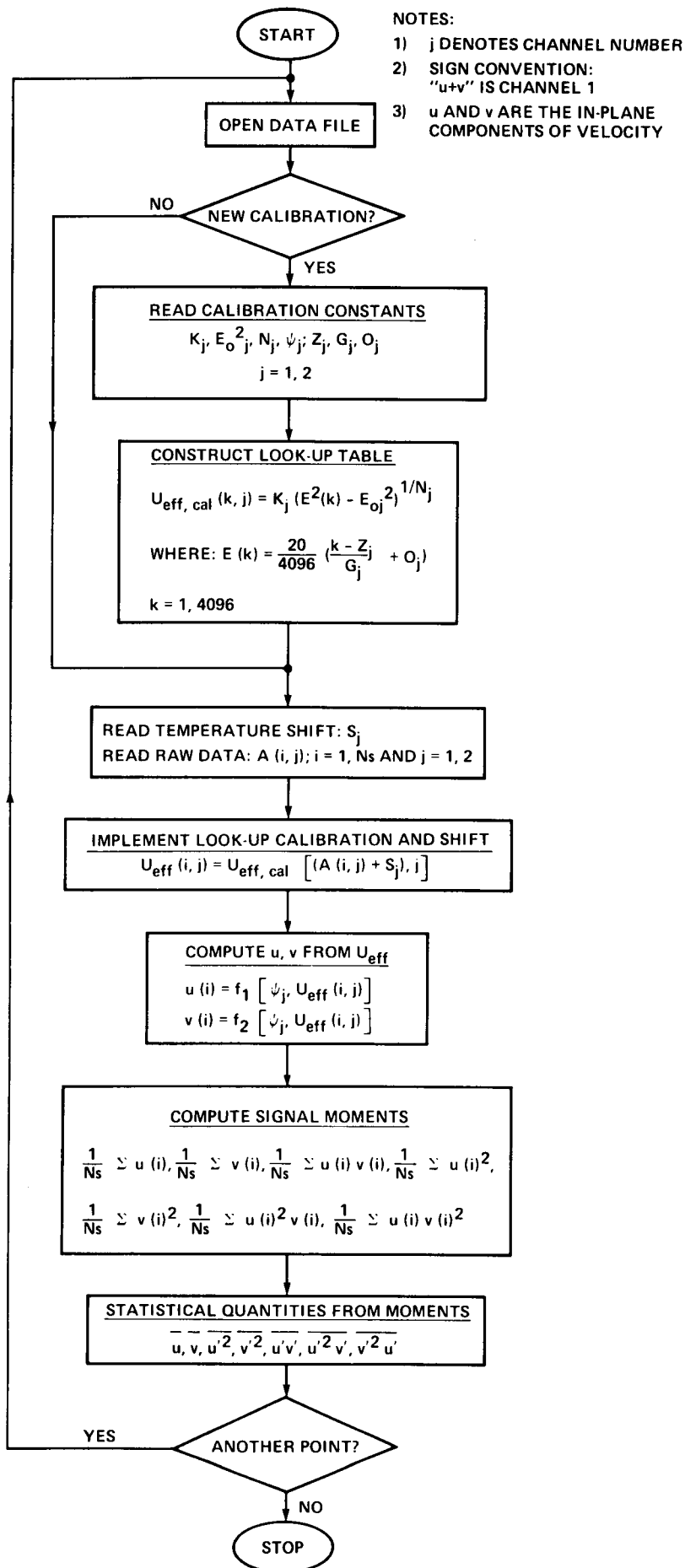

Figure 5.- Data-reduction algorithm.

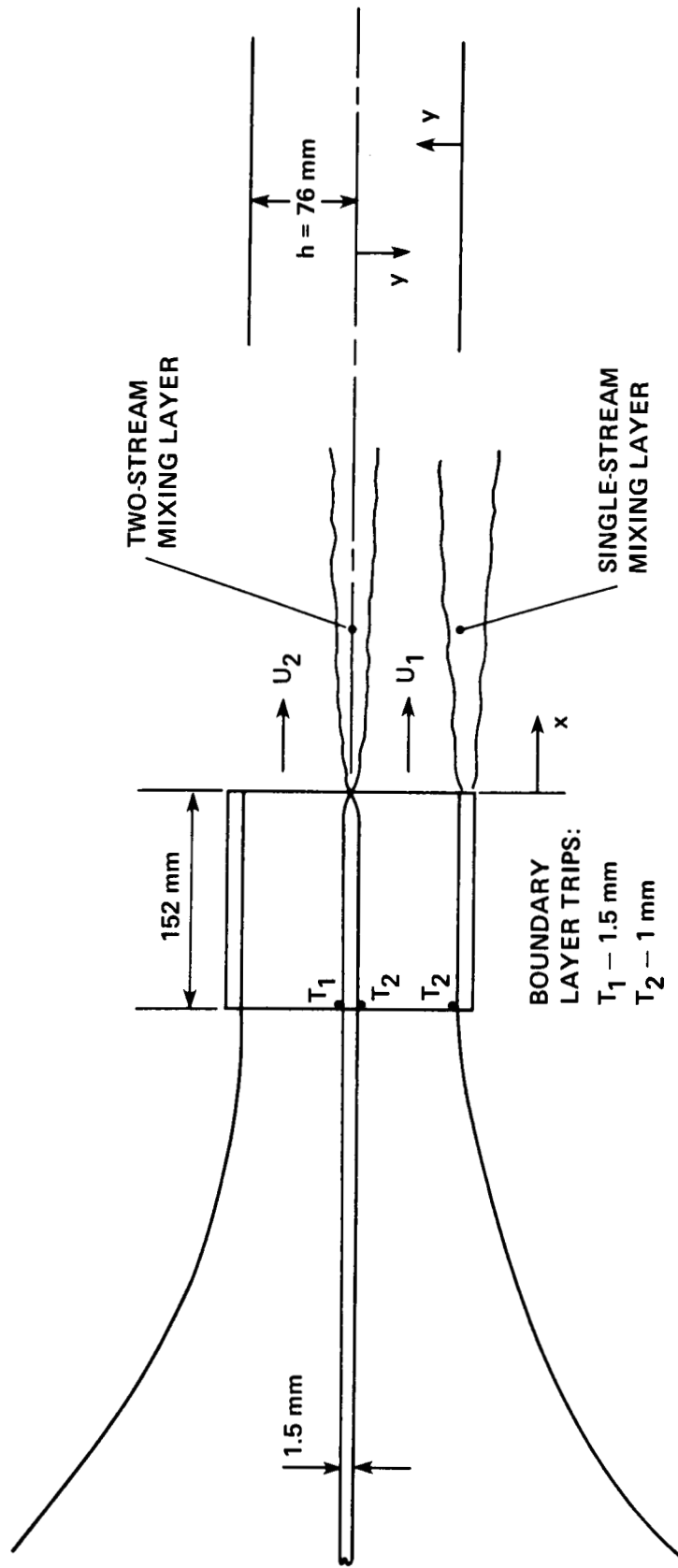

Figure 6.- Schematic of plane mixing layer experimental setup.

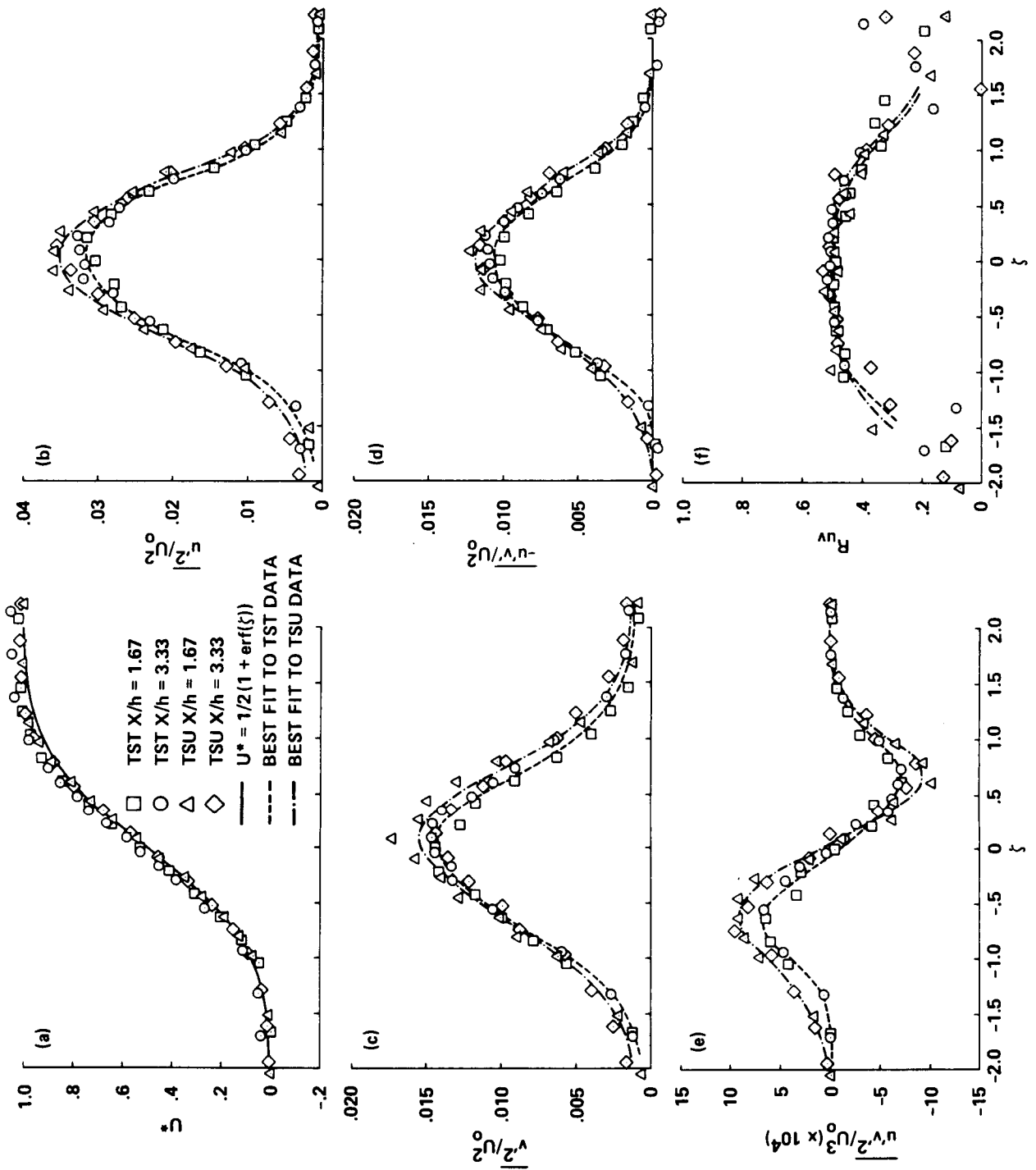

Figure 7.- Plane mixing layer: sample results.

| | | | |
|---|---|---|--|
| 1. Report No. NASA TM 85871 | 2. Government Accession No. | 3. Recipient's Catalog No. | |
| 4. Title and Subtitle CROSSED HOT-WIRE DATA ACQUISITION AND REDUCTION SYSTEM | | 5. Report Date January 1984 | 6. Performing Organization Code ATP |
| | | 8. Performing Organization Report No. A-9579 | 10. Work Unit No. T 4033Y |
| 7. Author(s) R.V. Westphal and R.D. Mehta | | 11. Contract or Grant No. | |
| 9. Performing Organization Name and Address NASA Ames Research Center Moffett Field, California 94035 | | 13. Type of Report and Period Covered Technical Memorandum | |
| | | 14. Sponsoring Agency Code 505-21-11 | |
| 12. Sponsoring Agency Name and Address National Aeronautics and Space Administration Washington, D. C. 20546 | | 15. Supplementary Notes Point of contact: R.V. Westphal, Ames Research Center, MS 227-8, Moffett Field, CA 94035; (415) 965-5856 or FTS 448-5856 | |
| 16. Abstract The report describes a system for rapid computerized calibration acquisition, and processing of data from a crossed hot-wire anemometer. Advantages of the system are its speed, minimal use of analog electronics, and improved accuracy of the resulting data. Two components of mean velocity and turbulence statistics up to third order are provided by the data reduction. The report presents details of the hardware, calibration procedures, response equations, software, and sample results from measurements in a turbulent plane mixing layer. | | | |
| 17. Key Words (Suggested by Author(s)) Hot-wire Two-component anemometer Cross-wire Automated data acquisition Turbulence measurement | | 18. Distribution Statement Unlimited Subject category: 35 | |
| 19. Security Classif. (of this report) Uncl. | 20. Security Classif. (of this page) Uncl. | 21. No. of Pages 41 | 22. Price* A-02 |