

NASA
TP
2289
c.1

**NASA
Technical
Paper
2289**

April 1984

Friction and Wear of Iron in Sulfuric Acid

George W. P. Rengstorff,
Kazuhisa Miyoshi,
and Donald H. Buckley

LOAN COPY: RETURN TO
AFWL TECHNICAL LIBRARY
KIRTLAND AFB, N.M. 87117





NASA
Technical
Paper
2289

1984

Friction and Wear of Iron in Sulfuric Acid

George W. P. Rengstorff

University of Toledo

Toledo, Ohio

Kazuhisa Miyoshi

and Donald H. Buckley

Lewis Research Center

Cleveland, Ohio

NASA

National Aeronautics
and Space Administration

Scientific and Technical
Information Branch

Summary

A fundamental investigation was conducted to determine the interaction of the corrosive media, sulfuric acid, with iron during sliding friction and wear experiments. An iron pin specimen with a tip radius of 3.2 millimeters was made to slide across an aluminum oxide surface in reciprocating motion at the relatively slow speed of 9 centimeters per minute under a load of 2.5 newtons. The aerated sulfuric acid ranged from a very dilute 0.7×10^{-4} N (4 ppm) to a highly concentrated 96 percent.

In the most dilute range of 0.7 to 2×10^{-4} N, a complex corrosion product built up on the surface of the iron. This resulted in erratic and often high friction due to the breakup of this friable, complex compound mixture on the wear surface. With the high friction was associated high metal wear losses.

At somewhat higher sulfuric acid concentrations (0.001 to 0.1 N) the total loss of metal in the wear spot was at a minimum: There was no buildup of corrosion products. The amount of metal lost at 0.001 N, as calculated from the microscopically observed size of the wear spot, was taken as a base to determine the contribution of direct corrosion loss to overall metal loss during the wear tests.

At acid concentrations of 5 to 50 percent, the well known high corrosion rates of iron dominated the metal losses in the wear experiments.

At acid concentrations of 65 to 96 percent, the contribution of direct corrosion to total metal loss in the wear area did not fall to a low value as might be expected from the known good resistance to corrosion of iron in concentrated sulfuric acid. Wear apparently continually removed the passivating film from the wear area and allowed a galvanic cell to develop between the wear area and its surroundings. Thus, iron dissolved readily from the wear area.

The experiments revealed a tendency for the coefficient of friction to be low when the most rapid direct corrosion occurred. Pictures taken with the scanning electron microscope helped to elucidate details of the contribution of corrosion to overall wear.

Introduction

Corrosion has been recognized as an important variable in the friction and wear of metals (ref. 1). Still, its role is not well understood. Most studies have concerned specific practical problems, such as the use of anticorrosion additives in lubricants (ref. 2) or moving parts in body implants (ref. 3). However, general basic knowledge is missing.

The effects of corrosion are complex. There is the general attack of surfaces with no particular effect in the wear contact region. However, the wear contact region differs electrochemically from the surroundings. It con-

tains metal that is cold worked, that is being highly stressed elastically as well as plastically, and that is at locally high temperatures at shearing points (refs. 4 and 5). Electrochemical potentials can be established locally to either impede or enhance corrosion. Furthermore the high cyclic stresses may promote stress corrosion and corrosion fatigue (ref. 6).

Resistance to corrosion is often the result of the formation of some type of a film on the metal surface. Wear can destroy such films. Alternatively, wear could develop better corrosion-resistant films by producing new surfaces. Further, the coefficient of friction is, like corrosion resistance, highly sensitive to surface films.

A preliminary study of the effect of a number of corrosive solutions on the friction and wear of iron was previously reported (ref. 7). Thereafter a comparison of friction and wear of iron and nickel in sodium hydroxide was published (ref. 8). Iron in sulfuric acid is the subject of this report. A companion report discusses nickel in sulfuric acid (ref. 9).

Materials

The iron (better than 99.99 percent pure) was annealed to a hardness of 30 to 35 Rockwell B after machining.

The sulfuric acid was ACS reagent grade concentrated acid, which is specified to be 95.5 to 96.5 percent by weight. The water used to make the solutions was deionized, distilled, and saturated with room temperature air.

Apparatus

Each of the bullet-shaped, 6.4-millimeter (1/4-in.) diameter iron riders used had a tip radius of 3.2 millimeters (1/8 in.) and was 16 millimeters (5/8 in.) long overall. Each was mounted in a holder and slid over a flat of aluminum oxide (sapphire). These tests differed from previously reported research, in which a sapphire ball rider was moved over a flat metal specimen.

The friction apparatus is shown schematically in figure 1. The aluminum oxide flats were attached to the bottom of glass cups (fig. 2). In operation, the cups were filled with the acid solution to about 3 millimeters above the surface of the flats. A metal cylinder was attached to the bottom of the cups so they could be held in a vise and reciprocated under the metal slider during the experiment. The cups were the bottom sections cut from 30-milliliter Pyrex beakers.

Epoxy cement was used to attach the flats to the inside bottom of the cups. A general-purpose epoxy cement was serviceable through 65 percent sulfuric acid. A high-density epoxy cement designed for high-vacuum environments withstood the 75 percent sulfuric acid solu-

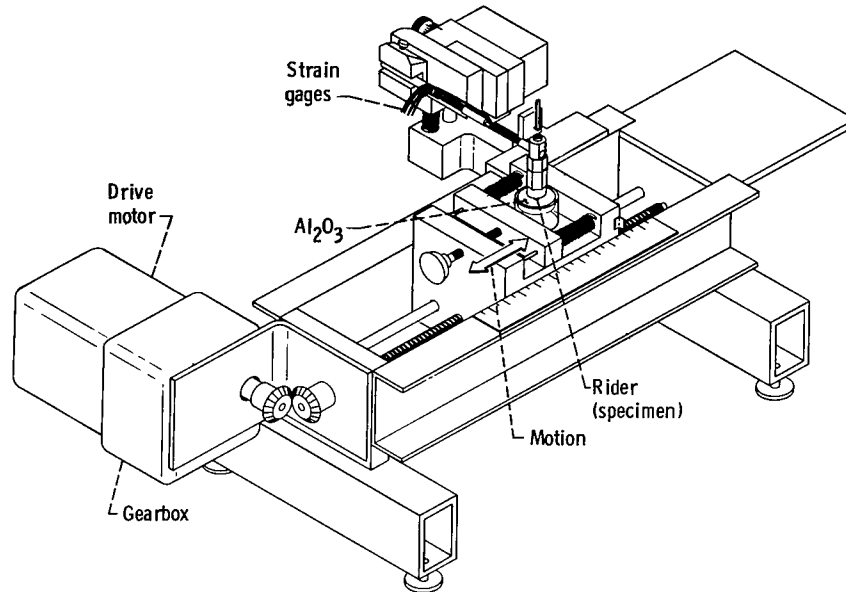

Figure 1. - Friction and wear apparatus.

tion. For the 96 percent acid solution a similar cup out of polytetrafluoroethylene (PTFE) was made. A groove was cut into the bottom inside the PTFE cup, and the flat was fit tightly in the groove so that a cement was not needed. The bottom cylinder for holding the cup in the vise was machined from the same piece of material as the cup itself.

As indicated in figure 1 the mounted flats were moved back and forth under the loaded iron rider. The motion of the flats was 1 centimeter in each direction. The wear motion was variable and shorter because of the friction drag. The rider load was 2.5 newtons (250 g). The arm holding the rider was flexible, so the friction force F could be measured with calibrated strain gages and continuously recorded.

There were nine reversals per minute, that is, the aluminum oxide flat travelled at an average speed of 9 centimeters per minute. Each experiment lasted 60

minutes. Thus, the rider passed over the flat 540 times (270 times each way) during an experiment. The experiments were carried out in air, so the acid was standardized in the aerated condition.

Experimental Procedure

The hemispherical tips of the iron riders were polished with 6- and 3-micrometer diamond paste. Finish polishing was with a wet metallographic polishing cloth impregnated with 0.3-micrometer α -aluminum oxide. The specimen was rotated in a small lathe for the polishing operation. Afterward, the polished tip was washed thoroughly, using a cotton swab to help remove the polishing powder.

The aluminum oxide flats in their cups were clamped in the jig. The specimens (the riders) in their holders were lowered to a few millimeters above the flats, and alignments were checked. Then the acid was dropped into the cups to cover the flats to the proper depth. Thereafter, the specimen tips were lowered until they just touched the flats, the 2.5-newton (250-g) load installed, and the experiment started.

The friction force F of the rider moving across the flat was determined by strain gages on the flexible arm that held the loaded rider. The output from the calibrated strain gages was recorded continuously. The coefficient of friction, then, was the force divided by the load of the rider (250 g). The static coefficient μ_s was the maximum F in each direction of travel or, as used, half the maximum force in a complete reversal of travel. The kinetic coefficient was estimated in the usual manner by using a force that was the mean between the maximum force (stick) and the minimum force (slip) when stick-slip occurred.

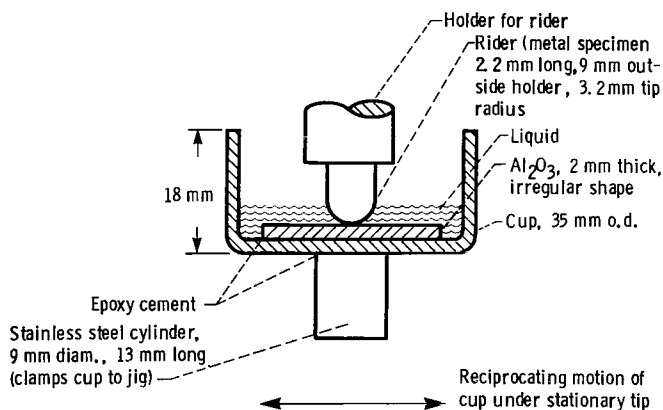

Figure 2. - Details of rider, Al_2O_3 surface, and cup for liquid.

The amount of metal lost in wear was determined by measuring the size of the wear spot on the tip after an experiment. The wear spot was photographed at a nominal magnification of 100. The maximum length of the spot, which occurred in the direction of motion, and the minimum length of the wear spot were measured on the photographic print. These were converted to true size using the correct magnification as determined by calibration. Then the amount of metal that would have been removed with a circular spot of the minimum length of the observed spot was calculated. The same calculation was made assuming that the wear spot had a diameter equal to its longer dimension. The two volumes were averaged to give an estimate of the amount of metal lost during the experiment. The volumes were calculated using the equation:

$$V = \frac{\pi}{3} [2R^3 - (2R^2 + r^2) \sqrt{R^2 - r^2}]$$

where

R radius of tip which was 3.2 millimeters (1/8 in.), and, for calculation purposes, was used as a constant 3.1750064 millimeters

r radius of the circular spot

The volume was calculated as 10^{-5} cubic millimeter and reported and used to one or, at most, two significant figures.

Estimation of Direct Corrosion Contribution to Metal Loss in Wear

A corrosive solution can influence metal loss in wear several ways. In particular, corrosion might overall or selectively in the wear area, remove iron in addition to the operation of normal wear phenomenon. In other cases corrosion products formed on the surface or deposited from solution can effect metal loss by changing the friction and by other indirect processes. This is an important effect for iron in very dilute solutions of sulfuric acid, as will be discussed later.

When the direct corrosion loss is great enough, it is possible to estimate corrosion rates in the wear area. Comparison with published corrosion rates and a comparison of the corrosion pattern in the wear zone with the pattern outside the wear zone provide some insight into the interaction of the corrosive solution and total wear losses.

The basic procedure to estimating corrosion rates in the wear zone was as follows:

(1) As a base, the wear spot diameter was used to calculate the volume of metal loss under conditions where the corrosive solution did not directly cause the corrosion

loss. For iron this base was the spot diameter of 0.23 millimeter and total loss of 5×10^{-5} cubic millimeter obtained with 0.001 N sulfuric acid.

(2) The total volume of metal lost due to the combined normal friction and corrosion was measured for each experimental condition. The volume lost under the base condition was subtracted from this to give the volume lost by corrosion.

(3) The average of the wear spot diameter for the solution under consideration and for base condition gives the diameter of a cylinder of metal lost by corrosion. Using this and the volume obtained in item (2) allow a calculation of the height of the cylinder. This height is the corrosion penetration in an hour. From it can be calculated the corrosion rate in millimeters per year and mils per year.¹ The rates in millimeters per year are given to the nearest calculation whole numbers; the rates in mils per year were rounded off to the nearest hundred, slightly more realistic, but probably of an accuracy greater than justified by the data.

The greatest cause of uncertainty comes from volume and average diameter errors due to the fact that the wear spots are not round. A further contributor to uncertainty is that the wear spots are not flat, as assumed in the calculations.

The effect of the assumption that corrosion has no effect on tip radius is minor. In fact, under the conditions of these experiments, the change in tip radius resulting from overall corrosion would give an undetectable difference from having all the corrosion localized in the wear spot.

Errors from the fact that the tip has a curved surface and that the corrosion calculation is based on a cylinder of average diameter are insignificant. The problem of choosing the base wear condition appears to be far overshadowed by uncertainties in volume and average diameter. Another questionable procedure is the comparison of 1-hour corrosion rates with published data, which were usually obtained over a much longer time. The general conclusion, however, is that the estimated corrosion rates are valuable supplements to other information about the wear-corrosion process. The specific values are suspect.

Another limitation of the estimation process is its inability to detect low corrosion rates. A corrosion rate of over 5 millimeters per year (200 mpy) is considered unacceptable for iron- or nickel-base alloys (ref. 10). Yet this rate would only change the diameter of a 0.23-millimeter wear spot to 0.25 mm, both of which are within the observable scatter band. Actually, the 7-millimeter-per-year (300-mpy) rate used as the detection limit in the tabulation is somewhat optimistic.

¹The unit meaning mils per year (mpy) has been standard for corrosion penetration. It is numerically similar to the true SI unit for which 1 mpy = 0.85 picometer per second (ref. 10).

Results and Discussion

The corrosion of iron in neutral water (pH = 7), slightly acid, or slightly basic is complex. Corrosion reaction products form on the surface, or are deposited on the surface which are recognized as a mixture of divalent and trivalent hydroxides, oxyhydroxides, and oxides (refs. 10 to 14). The conditions which lead to this are discussed briefly in appendix A. There is also XPS (X-ray photoelectron spectroscopic) evidence that iron sulfate may be part of the built-up layer (ref. 7). Sulfuric acid has the unusual behavior that, while it acts as a nonoxidizing acid at low to rather high concentrations, when it becomes even more highly concentrated, it acts as a strongly oxidizing acid.

Iron usually corrodes rapidly in nonoxidizing acids. If the oxidation is strong enough, iron passivates by forming a protective oxide layer. Iron's behavior in sulfuric acid is consistent with this generality. Steel drums can be used for storing sulfuric acid at room temperature between about 60 and 98 percent acid. In fact, the well-documented corrosion rates of three concentrations in the range used in this research are (ref. 10)

H ₂ SO ₄ concentration, percent	Corrosion rate, mm/yr (mpy)
65	0.5 to 1.0 (20 to 50)
75	.1 to 0.5 (5 to 20)
95	.1 to 0.5 (5 to 20)

Below about 60 percent sulfuric acid, the corrosion rates are so high that the use of steel in contact with the acid is impractical. The published corrosion rates of one laboratory study are shown in figure 3. Note that the corrosion rates at 25 and 50 percent sulfuric acid are thousands of times as high as at 75 percent acid.

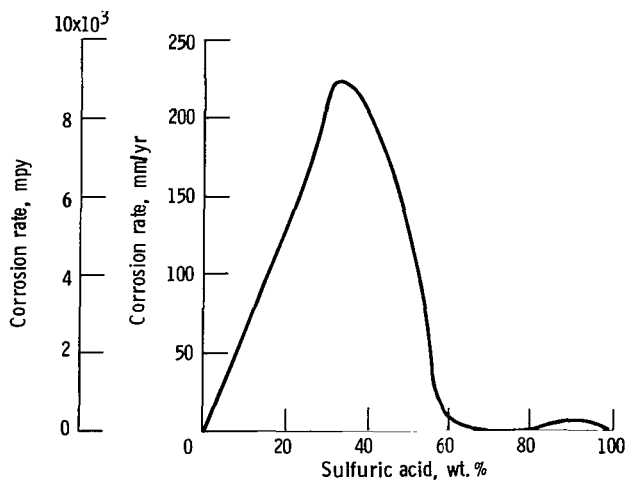

Figure 3. - Corrosion rate of steel in sulfuric acid (ref. 13).

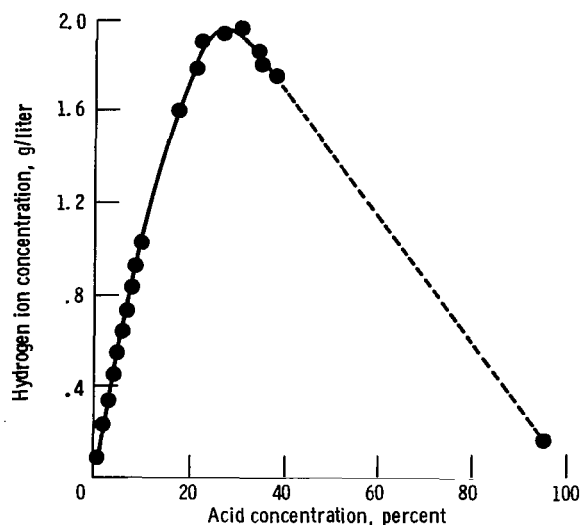

Figure 4. - Hydrogen-ion concentration of sulfuric acid at 77° F (refs. 13 and 15).

The passivating film is probably Fe₂O₃. However, Fe₂O₃ is soluble below a pH of about 2 (see appendix A). The pH is an inverse function of hydrogen ion concentration, so low or negative pH is associated with concentrated strong acids. Figure 4 shows that this is true for sulfuric acid, up to a point. As the hydrogen ion concentration increases, so pH decreases, up to about 30 percent acid. At higher concentrations the hydrogen ion concentration decreases, so pH increases again. At some higher concentrations, pH is high enough so that a Fe₂O₃ film continuous enough to passivate iron would not readily dissolve.

Experimentally Determined Surface Structures of Iron Wear in Dilute Sulfuric Acid

Figure 5 shows the friction and wear of iron tips operating in sulfuric acid at concentrations of 1.0 N (5 percent) or less. Photomicrographs of the wear spot of each specimen are shown.

A notable result was that friction and wear were highly variable in the very dilute sulfuric acid range of 7×10^{-5} to 2×10^{-4} N (4 to 12 ppm). The SEM photographs of figure 6 show a specimen operated in this range (10^{-4} N) where a high coefficient of friction ($\mu_s = 0.51$) was observed. The wear loss was high. On the other hand figure 7 presents SEM photographs of iron operated at the same concentration of acid but having a much lower friction coefficient ($\mu_s = 0.31$). The wear loss was correspondingly much lower.

In both cases a highly structured surface developed in the wear area as shown in figures 6(a), (b), and (e) and 7(a), (d), and (e). Some regions were cracked in the wear area, some were not. It is noteworthy that outside the wear area, a distinctive structure also developed (figs. 6(d) and (e) and 7(b)). It is in these specimens that a com-

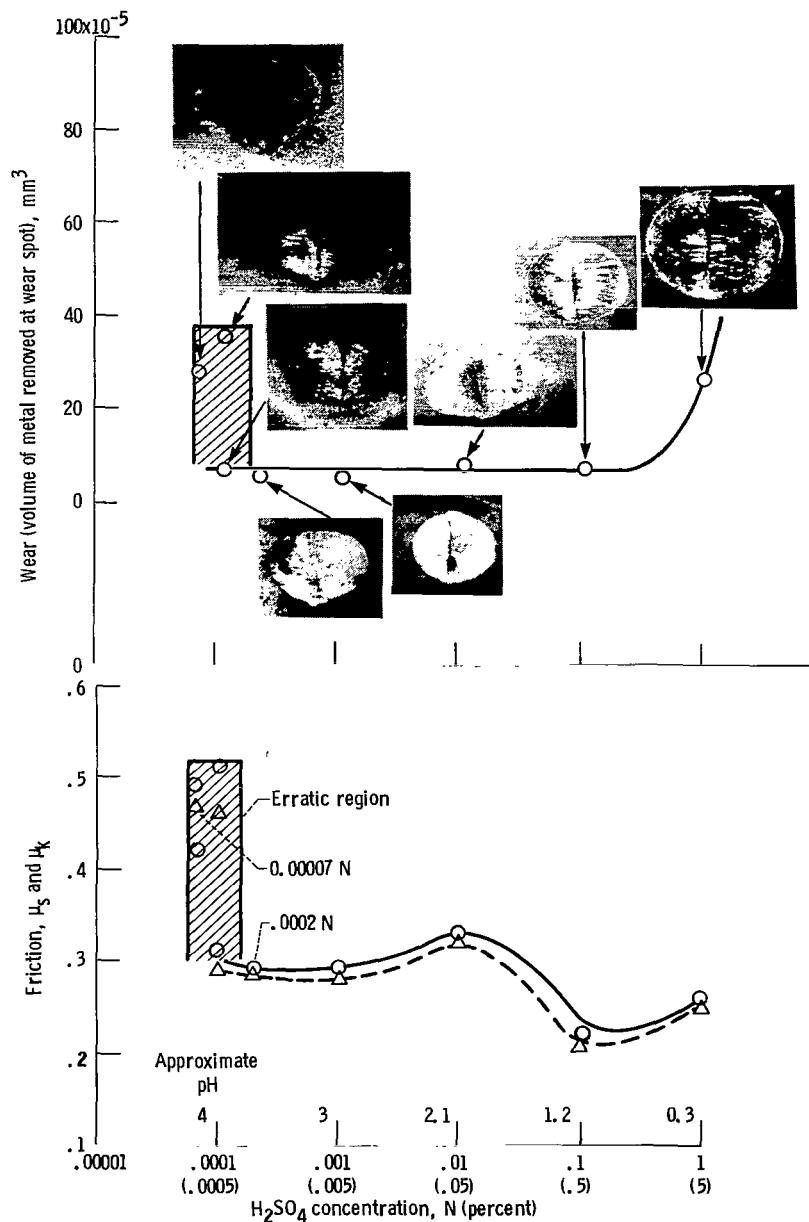

Figure 5. - Friction and wear of iron in dilute sulfuric acid.

plex surface deposit formed which consisted of iron hydroxides, iron oxides, iron oxyhydroxides, and perhaps iron sulfate. This condition was mentioned earlier and is amplified upon in appendix A.

The deposit was basically weak and friable and was not a protective, passivating film. Friction loading caused it to crack. In those regions where the deposit was thickest, cracking was so bad that the friction was raised and metal loss increased.

Figures 6 and 7 show that regions existed in both the high friction and the lower friction specimens where the deposit cracked under the friction load. The real dif-

ference was in degree. This is partially observable from the low-magnification SEM pictures. Figure 6(c) shows some of the massive fracturing which is believed to have led to the high coefficient of friction. Figure 6(b) shows that even most of the apparently smooth areas had cracks. On the other hand, figure 7(c) does not show obvious cracking. Cracks were much fewer and more localized in this specimen, which is consistent with the lower coefficient of friction.

Figure 8 shows SEM photographs of the iron tip operating in slightly more concentrated acid. The concentration was still low, only 2×10^{-4} N (12 ppm). In

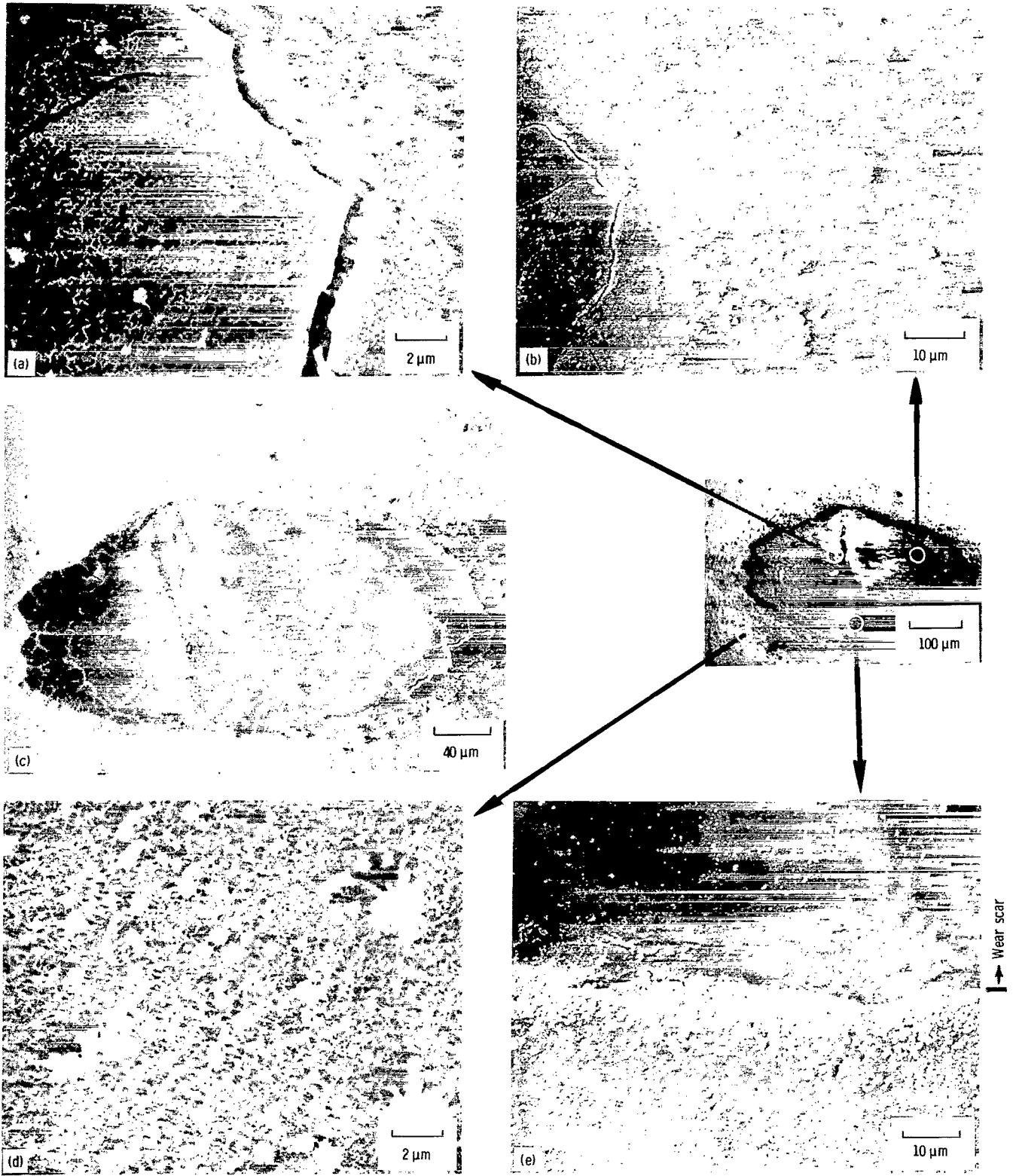

Figure 6. – SEM photographs of wear area of an iron tip in 10^{-4} N sulfuric acid. High friction ($\mu_s = 0.51$). Locations are as shown in the photomicrograph.

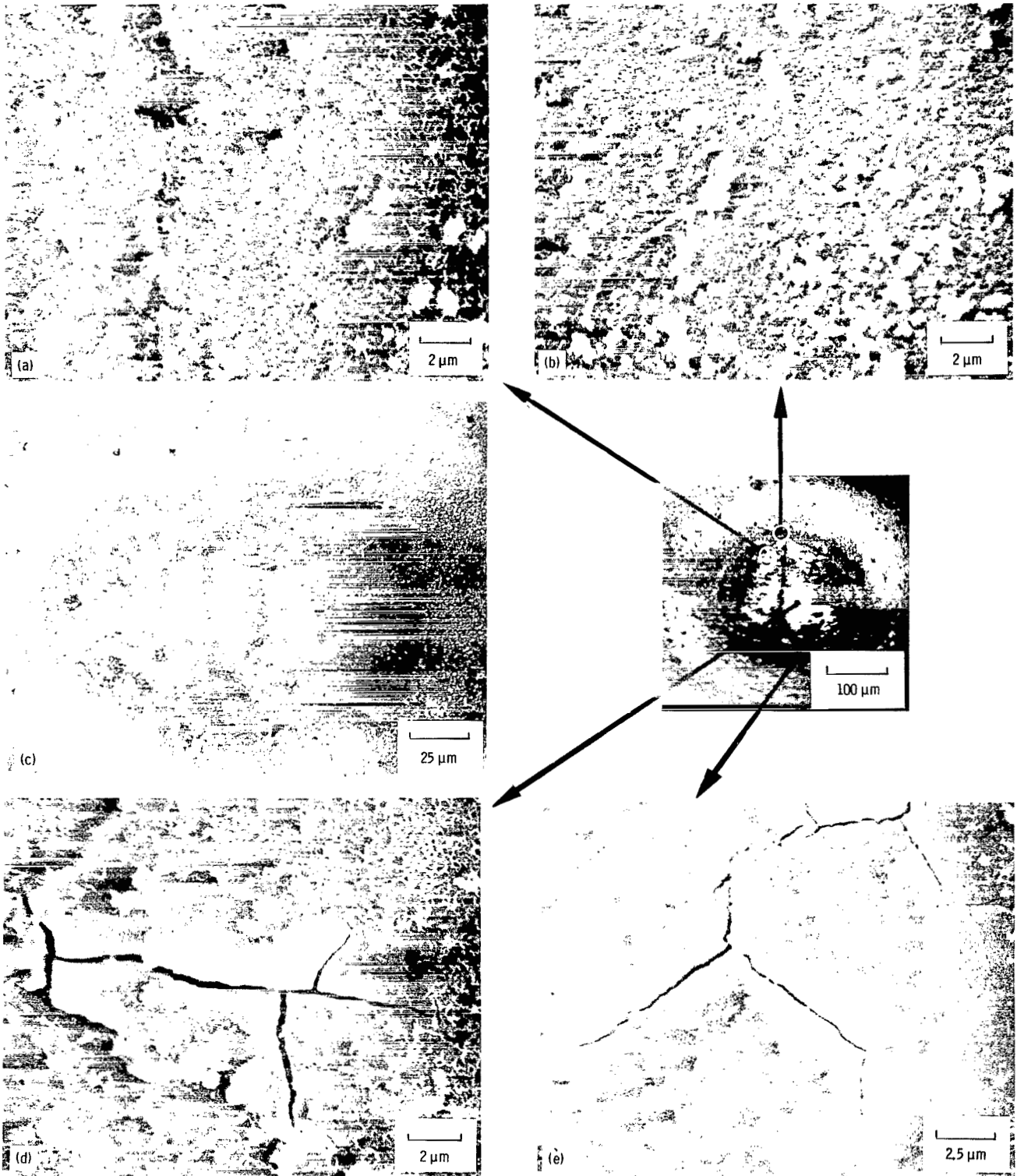

Figure 7. – SEM photographs of wear area of an iron tip in 10^{-4} N sulfuric acid. Moderate friction ($\mu_s = 0.31$). Locations are as shown in the photomicrograph.

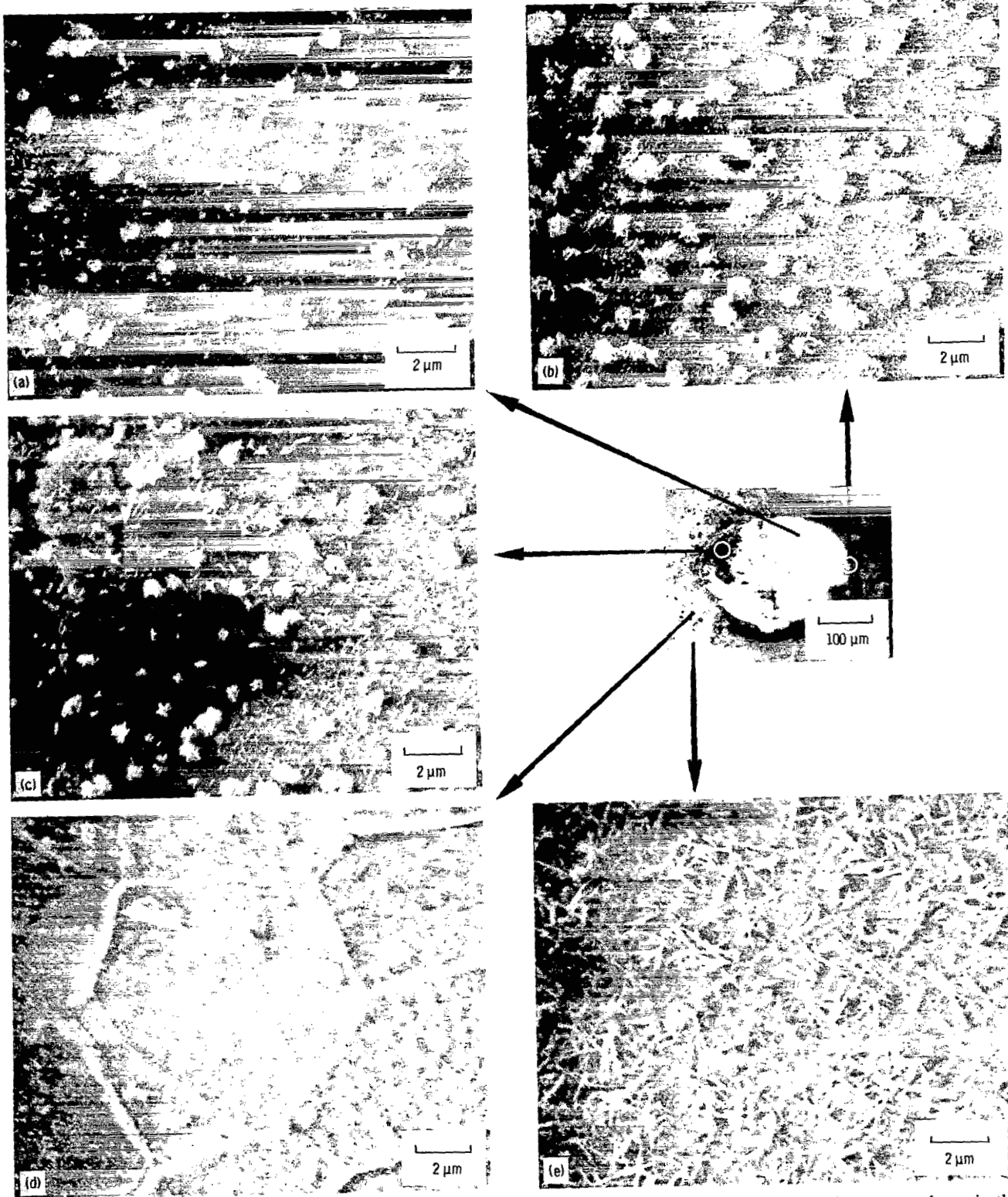

Figure 8.—SEM photographs of wear area and surroundings of an iron tip in 2×10^{-4} N sulfuric acid. Locations are as shown in the photomicrograph.

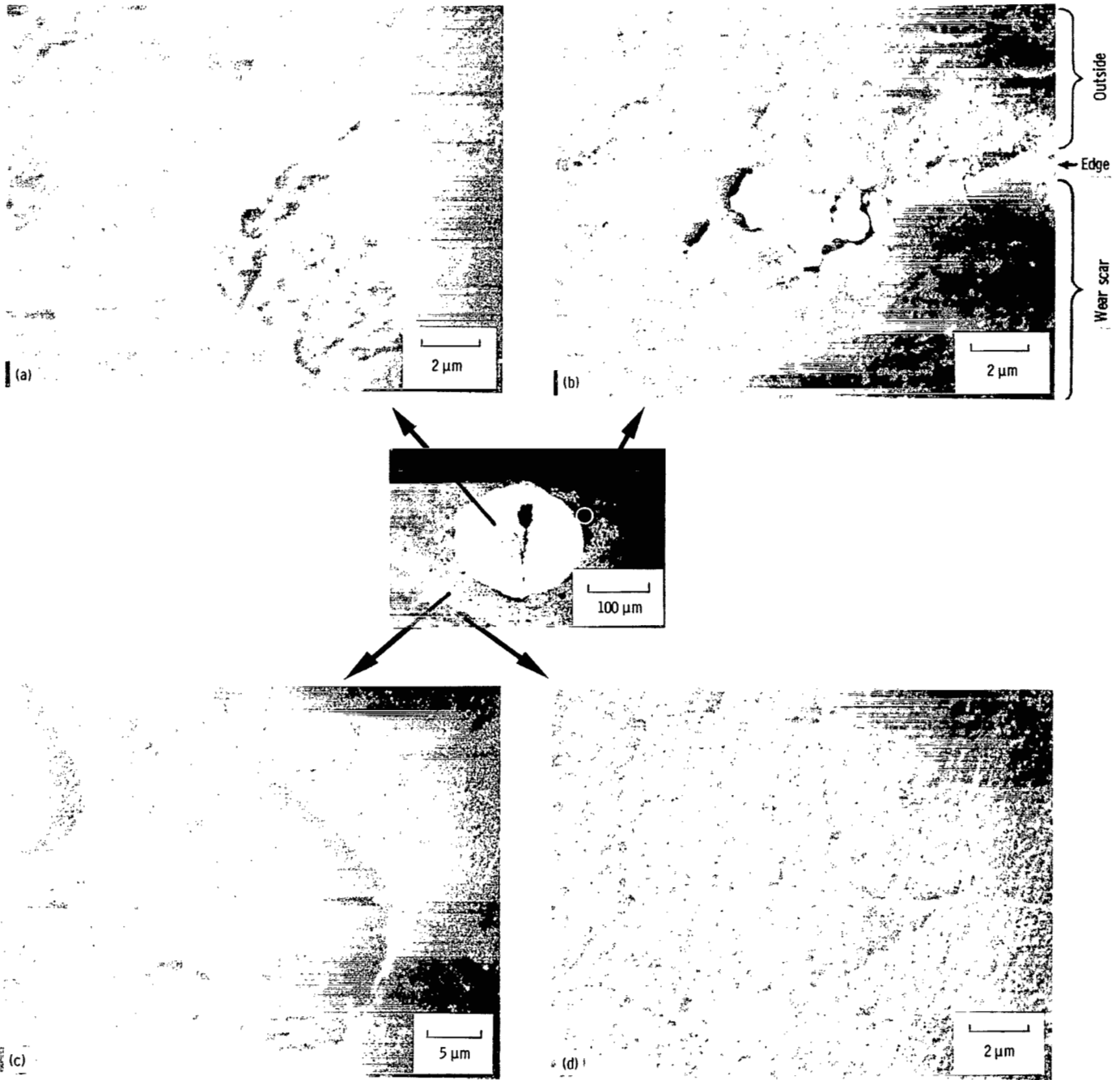

Figure 9.—SEM photographs of wear area and surroundings of an iron tip in 0.001 N sulfuric acid. Locations are as shown in the photomicrograph.

general, figure 8 shows the same type of deposit in the wear area and outside. However, there was only one small edge region where cracks occurred in the deposit in the wear area (fig. 8(c)). Also, there was a halo region around the wear spot where grain boundary etching was observed. Figure 8(e) shows an exceptionally heavy buildup of oxidation products well outside the wear area.

Figure 9 shows the SEM photographs of an iron tip operated in 0.001 N (0.005 percent) sulfuric acid. In this case there was little evidence of buildup of corrosion products on the surface. Figure 9(a), typical of almost the entire wear spot, shows a very smooth surface. Figure 9(b) shows some cracked deposit. The structure that cracked was highly localized to a thin band in only a small pro-

portion of the edge region. Figure 9(c) shows the smooth surface of the corroded halo area around the wear spot. Figure 9(d) shows the etched region well away from the wear area. There was none of the dendritic buildup of deposited corrosion products on the iron observed in figures 6, 7, and, particularly, 8.

Because of the small amount of wear and the general pattern of corrosion and wear, the volume of metal and size of this wear spot (0.001 N) was taken as the base condition for estimating the amount of contribution of direct corrosion on the removal of metal during wear. The direct corrosion losses as determined by these calculations are given in table I. Note that there are no calculations for acid concentrations below 0.001 N. The formation of corrosion products on the surface and their effect on friction and wear mask effects from direct removal of metal by corrosion.

The SEM photographs of iron worn in a concentration of 0.1 N acid show the scratched pattern commonly found in metal wear. Few, if any, effects of buildup of precipitated corrosion products were present. Table I indicates no measurable amount of direct corrosion solution adding to the wear loss. There was no corrosion halo around the wear spot. Instead, there was light corrosion etching of the iron up to the edge of the wear spot.

Figure 10 shows the SEM photographs of the iron worn in 1.0 N (5 percent) acid. The surface inside the wear spot is quite smooth (figs. 11(a) to (c)). Variations exist which result in the light and dark areas in the photomicrograph, but these variations are not large. Outside the wear spot, the grain boundaries of the iron are etched rather sharply. This is especially visible in figure 11(c).

Table I shows that the estimated corrosion rate was much higher, high enough to materially add to the metal lost by basic friction effects at 5 percent acid (1.0 N). In fact, the estimated rate of 27 millimeters per year (1100 mpy) is close to the 30 millimeters per year (1200 mpy)

shown for this concentration in figure 3, as taken from the literature. This leads to the conclusion that the corrosion loss in the wear spot probably was about the same as the overall corrosion loss. There does not appear to be a strong galvanic cell formed between the wear spot and its surroundings.

Surface Structures of Iron Wear in Concentrated Sulfuric Acid

Figure 11 shows the friction and wear of iron after operating in 30, 50, 65, 75, and 96 percent sulfuric acid. For comparison the data points for iron after operating in 5 percent (1.0 N) acid are repeated from figure 5.

From the wear loss at 5 percent acid, the wear increased sharply to a maximum at 30 percent acid, then dropped sharply to 50 percent acid, and a little more to 65 percent acid. At 75 percent acid, wear loss was a little higher and was much higher at 96 percent acid.

This pattern differs in several important ways from the pattern of corrosion rates of iron in the absence of wear. The differences between the wear and no-wear effects will be discussed for each experiment and probable explanations presented.

Over this composition range, the static coefficient of friction μ_s ranged between 0.28 and 0.18. There is no clear pattern to the variations, except to note that the highest corrosion rate was accompanied by the lowest μ_s .

Stick-slip increased markedly at the higher acid concentrations. Thus, figure 11 shows greater differences between μ_s and μ_k than figure 5, which is a plot for a more dilute acid.

Figure 12 shows SEM photographs of the iron rider after operation in 30 percent acid. Figures 12(a) to (c) show grain-boundary etching even in the wear spot, where cold deformation would tend to smear the surface. Still, corrosion did not produce faceted corrosion patterns as in the wear spots of nickel, corroded under similar conditions (ref. 9). Significantly the iron outside the wear spot shows (figs. 12(c) to (e)) the faceted rapid corrosion pattern.

The estimated corrosion rate (table I) in the wear spot of 93 millimeters per year (3600 mpy) is less than the published value of 220 millimeters per year (9000 mpy) given in figure 3. This, plus the structure comparison between the region inside and outside the wear spot, leads to the conclusion that the wear spot was not anodic to its surroundings. It is probable that the large loss in the wear test was almost entirely the result of the high overall corrosion rate of iron in 30 percent sulfuric acid.

Figure 13 shows SEM photographs of the region of the wear area of the iron rider after operation in 50 percent acid. Figures 13(a) and (b) show a moderate roughening of the surface of the region within the wear spot. Figures 13(a), (c), and (e) show the faceted corrosion outside the

TABLE I. - ESTIMATED CORROSION RATES OF WEAR SPOTS OF IRON TIPS OPERATED IN SULFURIC ACID

H ₂ SO ₄ Concentration	Corrosion rate	
	mm/yr	mpy
0.001 N (0.005 percent)	^a 0	^a 0
0.01 N (0.05 percent)	<7	<300
0.1 N (0.5 percent)	<7	<300
1 N (5 percent)	27	1100
30 percent (7½ N)	93	3600
50 percent (15 N)	43	1700
65 percent (21 N)	25	1000
75 percent (25 N)	27	1100
96 percent (35½ N)	57	2200

^aCalculation base.

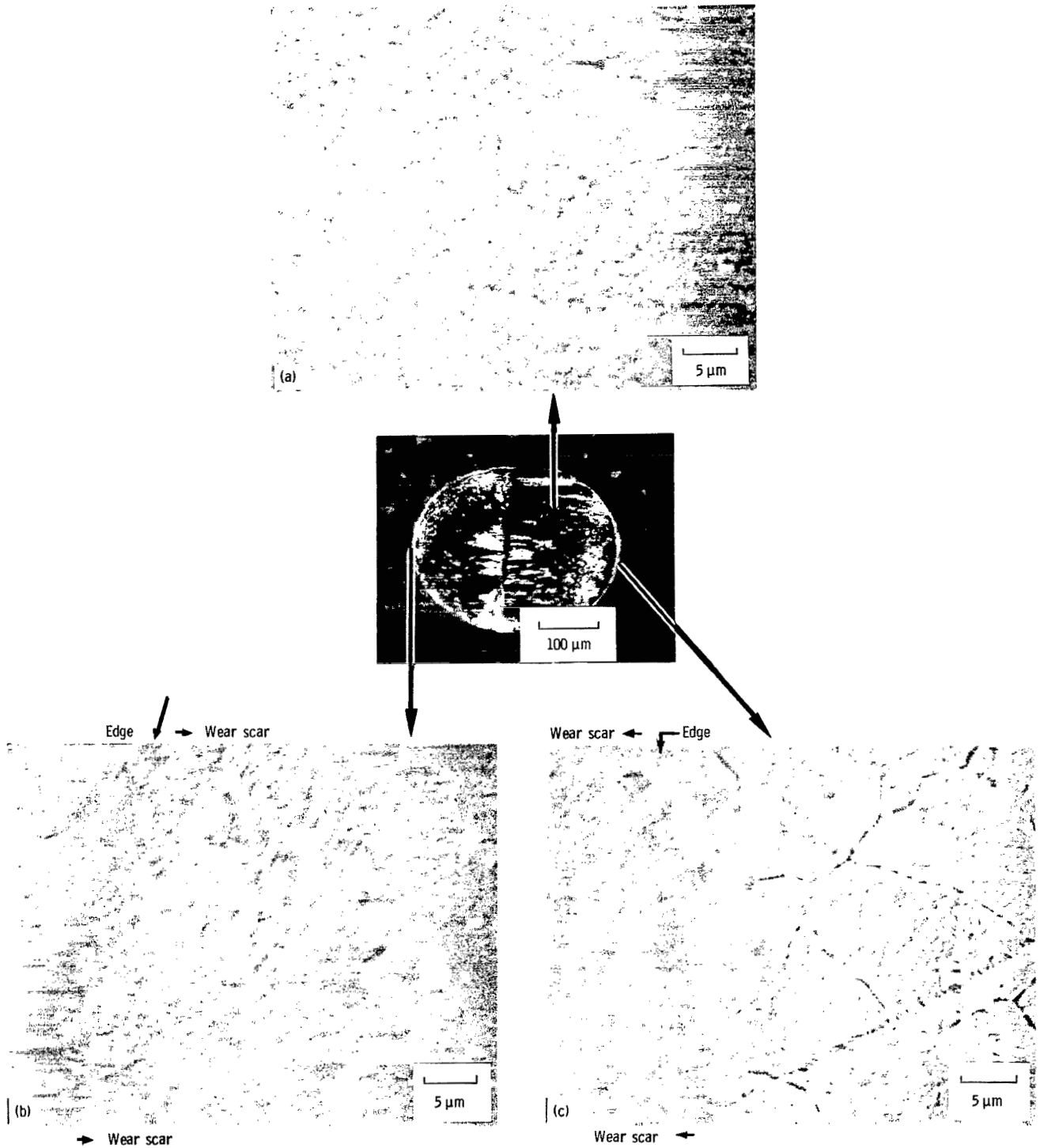

Figure 10. —SEM photographs of wear area and surroundings of an iron tip in 1.0 N sulfuric acid. Locations are as shown in the photomicrograph.

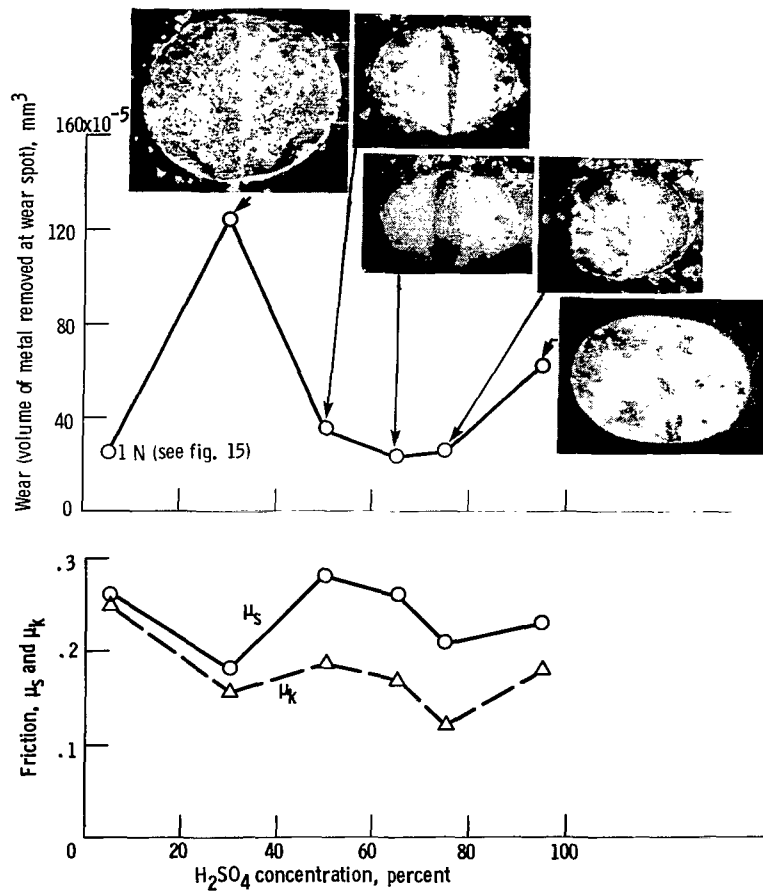

Figure 11. - Friction and wear of iron in concentrated sulfuric acid.

wear spot (also observed the fig. 12 for 30 percent acid). However, this outside corroded surface does not appear to be as deep as that at 30 percent acid.

The estimated corrosion rate at the wear spot for 50 percent acid is 43 millimeters per year (1700 mpy). This is one-third the published corrosion rate of 125 millimeters per year (5000 mpy) for iron given in figure 3. This difference may be due to a buildup of a limited protective coating on the iron grains in some orientations. This may account for the patches in figure 13(c) and (e). In any case it is clear that the corrosion enhancement of wear loss is not due to the wear spot becoming anodic to its surroundings.

Many times, the appearance of a structure is different in a SEM from its appearance at about the same magnification in a light microscope. As an example, figure 13(d) shows an SEM picture magnified to about 1 1/2 times the photomicrograph alongside. The apparent undulating surface in the SEM around the center line area appeared to be a manifestation of a major wear-corrosion interaction. However, the higher magnification of the center line area in figure 13(f) shows only minor variations in local corrosion patterns. The apparent surface undulations in figure 13(d) are probably only a shadowing effect.

The iron tip worn in 65 percent acid was not studied with the SEM. It appears to be very similar to the tip worn in 75 percent acid, whose SEM photographs are shown in figure 14.

A phenomenon that is especially notable for the tips worn in 96 percent acid, as well as in 65 percent and 75 percent acid, is the high corrosion losses. The corrosion rates are much higher than the well-known low rates of steel in the same acids without simultaneous wear.

As given in table I, the corrosion contribution to wear loss is estimated at 23 millimeters per year (1000 mpy) for 65 percent acid, 27 millimeters per year (1100 mpy) for 75 percent acid, and 57 millimeters per year (2200 mpy) for 96 percent acid. This compares with the rates of less than 1 millimeter per year (50 mpy) discussed earlier (ref. 10). This must mean that the passivating layer is being worn away in the wear spot, making the wear spot anodic with respect to its surroundings.

The SEM photographs in figure 14 for 75 percent acid are somewhat ambiguous in their ability to confirm this speculation about the local wear corrosion effect. The wear spot is rather smooth (fig. 14(a)). The iron outside the wear area is roughly corroded (fig. 14(c)). The sharp edge to the wear spot (fig. 14(b)) might be showing a step

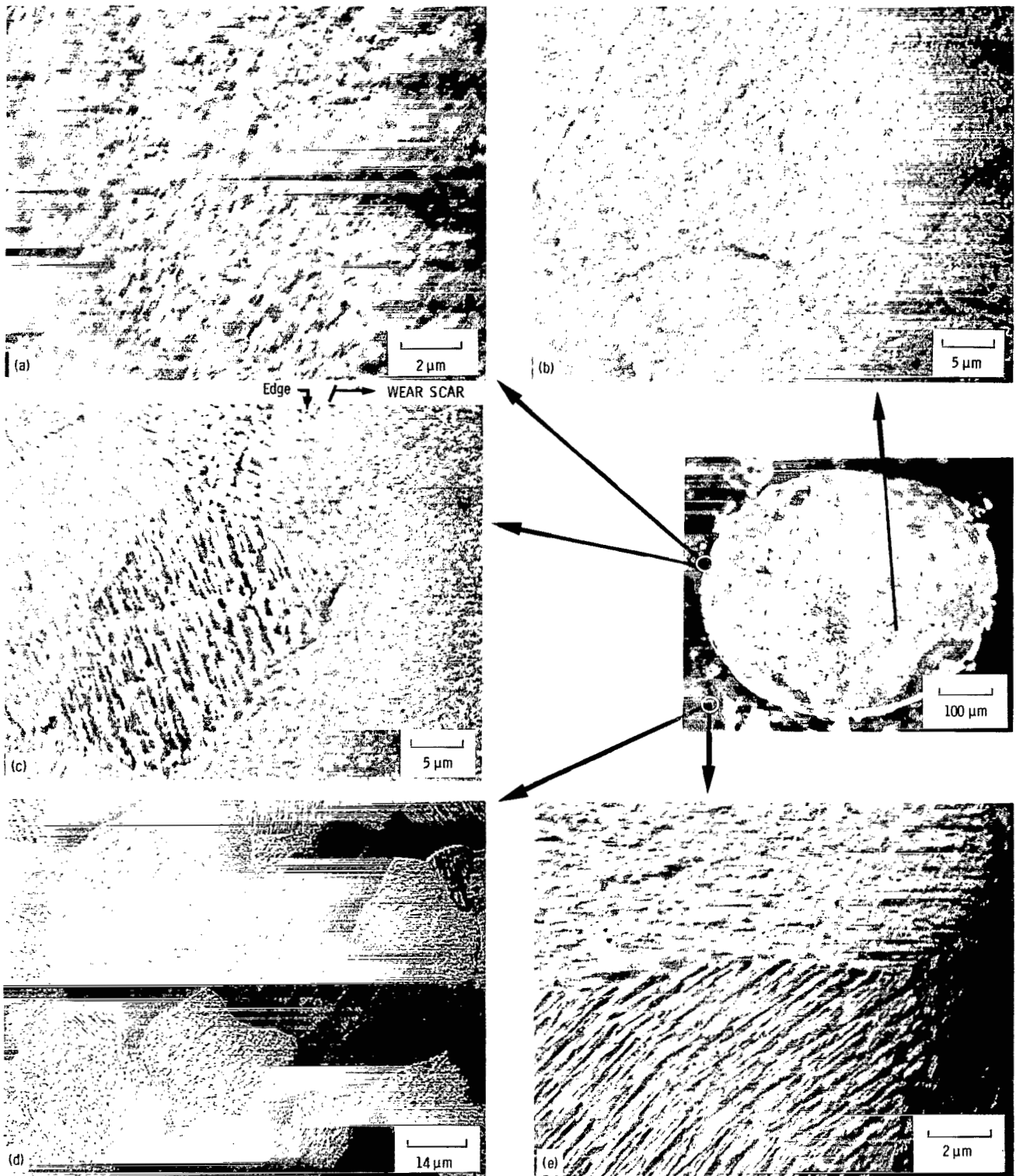

Figure 12. — SEM photographs of wear area and surroundings of an iron tip in 30 percent sulfuric acid. Locations are as shown in the photomicrograph.

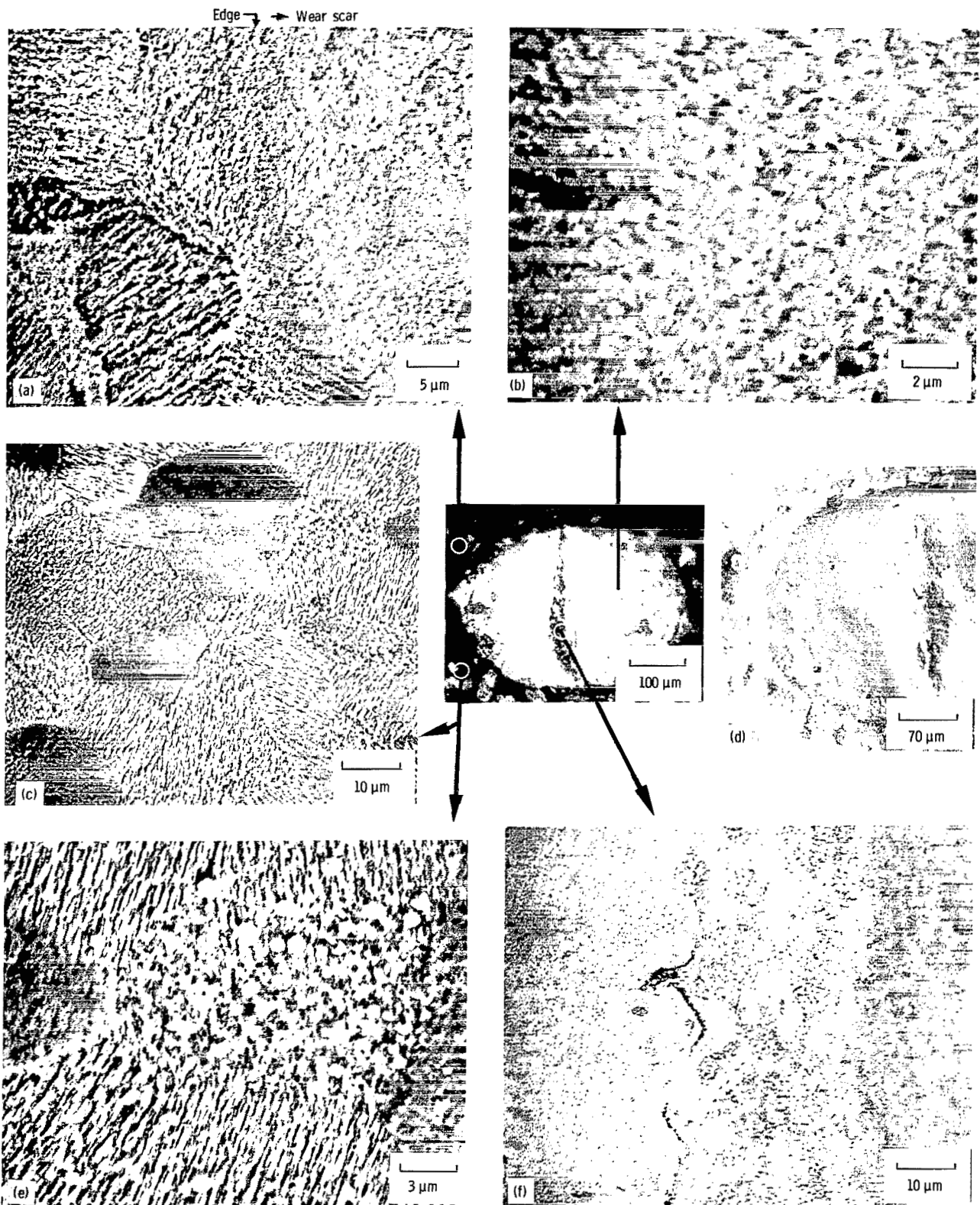

Figure 13. – SEM photographs of wear area and surroundings of an iron tip in 50 percent sulfuric acid. Locations are as shown in the photomicrograph.

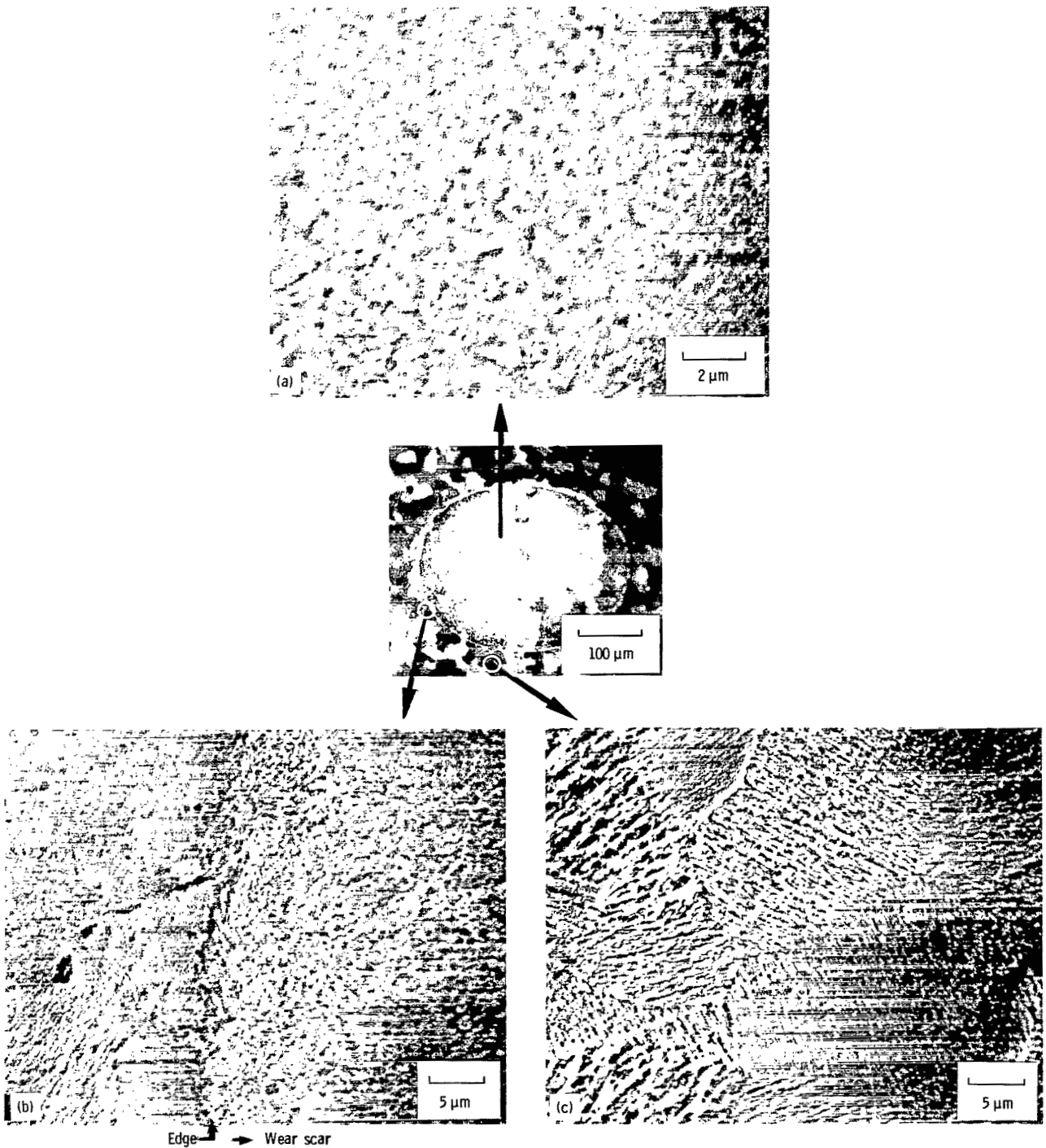

Figure 14. –SEM photographs of wear area and surroundings of an iron tip in 75 percent sulfuric acid. Locations are as shown in the photomicrograph.

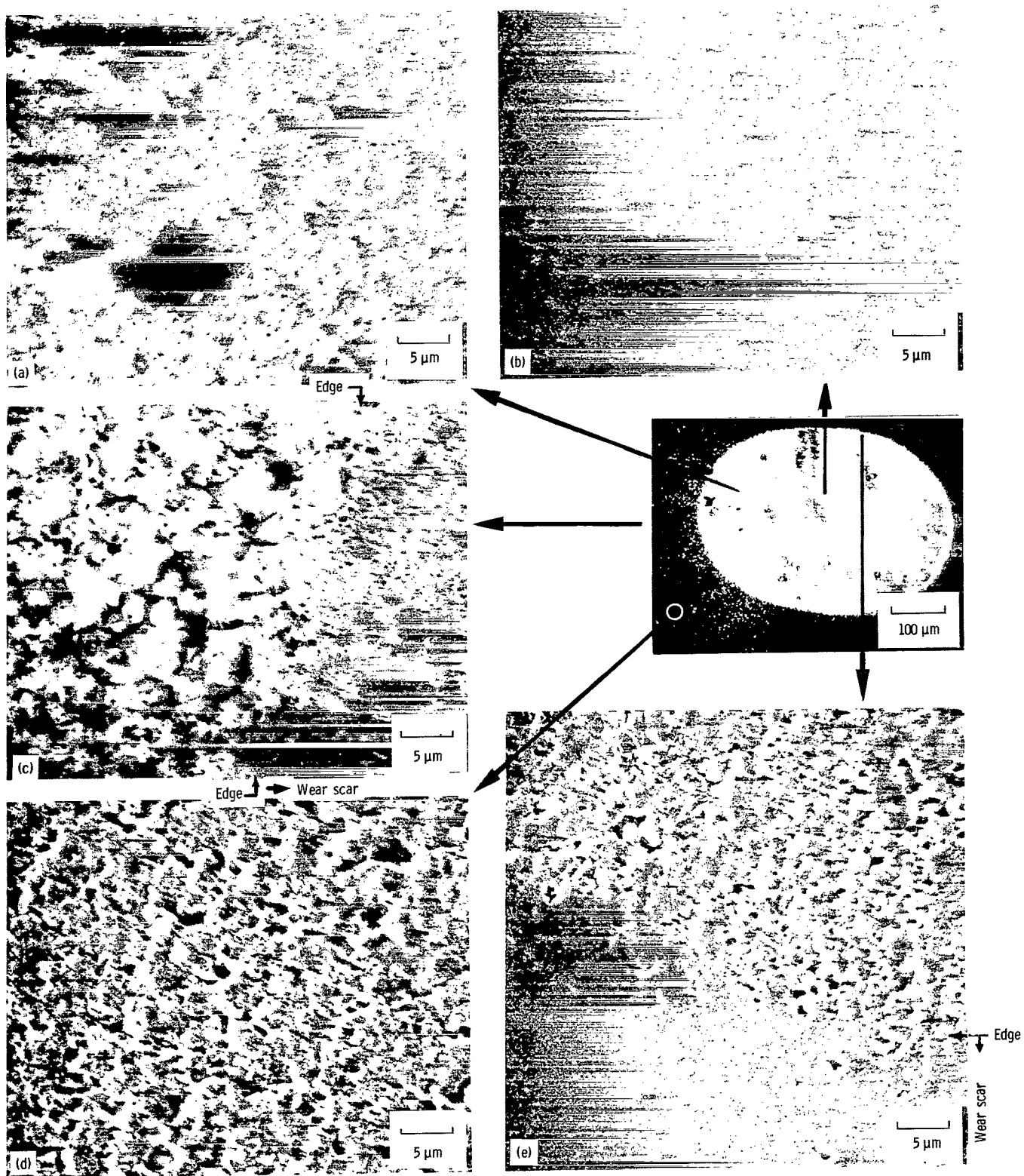

Figure 15. – SEM photographs of wear area and surroundings of an iron tip in 96 percent sulfuric acid. Locations are as shown in the photomicrograph.

down going from the outside to inside the wear spot. Such a ledge might be expected if the wear spot is anodic. However, the considerable depth of focus of the SEM makes clear interpretation difficult.

At 96 percent acid the edge to the wear spot is blurred (figs. 15(c) and (e)). If there is a drop in level, it must be gradual. Also, although the corrosion contribution to metal loss is high, the relative structure between the wear spot and the surroundings is opposite to that of nickel: At some corrosion rates, the nickel in the wear spots was rougher than the surroundings (ref. 9), but the surroundings were rougher than the wear spot in iron. Still, the preponderance of evidence points to the same method of corrosion of iron in 65, 75, and 96 percent acid as for more dilute acids on the corrosion of nickel (ref. 9); that is, wear sets up a galvanic couple, with the wear area rapidly dissolving as an anode.

Conclusions

The experimental data for variations of loss of iron sliding on aluminum oxide in aerated sulfuric acid with concentrations ranging from very dilute to very concentrated has been presented. Conclusions and results derived from differences in behavior of iron in various acid concentration ranges were

1. At the very dilute acid concentrations of 0.7 to 2×10^4 N (4 to 12 ppm) corrosion produced a soft, friable deposit on iron. Breakup of this hydroxide-oxide-oxyhydroxide-sulfate deposit gave erratic and often high loss of iron in the wear area.

2. At somewhat higher sulfuric acid concentrations (0.001 to 0.1 N), the loss of metal in the wear region was

at a minimum, and there was no buildup of corrosion products.

3. At 5 percent (1.0 N) and 30 percent acid the well-known high and direct solution loss of iron due to corrosion dominated the overall loss of iron in the wear contact zone. This effect dropped at 50 percent acid, but direct corrosion loss was still dominant over loss due to normal friction effects.

4. At 65 to 96 percent sulfuric acid it might be expected that loss of metal due directly to corrosion in the wear region would be low. It was not. It was concluded that friction and mechanical wear removed the passivating coating which protects iron from corrosion in concentrated sulfuric acid. Thus, a galvanic cell was established between the wear spot and its surroundings which greatly increased the loss of iron in the wear area.

5. A correlation between coefficient of friction with acid concentration was not particularly clear. However, the following general observations were made:

- a. At the very low sulfuric acid concentrations where a friable corrosion product developed on the iron, those specimens having unusually high friction coefficients also had high metal loss in wear.

- b. Over the entire acid concentration range, the highest direct corrosion loss was associated with the lowest coefficients of friction.

- c. At acid concentrations of 5 percent (1.0 N) and below, little or no stick-slip was observed. On the other hand, at acid concentrations of 30 percent and higher, μ_s was consistently appreciably higher than μ_k .

National Aeronautics and Space Administration
Lewis Research Center
Cleveland, Ohio, December 27, 1983

Appendix A—The Formation of Corrosion Products in Water Which is Neutral, Slightly Acid, or Slightly Basic

The corrosion of iron with the accompanying formation of oxidation products on the surface is a most complicated process (refs. 10 to 13). It starts with a simple, and almost universally accepted, anodic reaction:

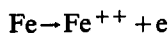

Trivalent iron ions do not form directly in measurable quantities in the anodic reaction, and complex ions only form directly in special solutions.

The Fe^{++} ions dissolved in the solution can take part in several parallel reactions:



In this case, the $\text{Fe}(\text{OH})_2$ might deposit on the surface, where a series of other reactions can occur. It might remain in solution and be oxidized according to the reaction

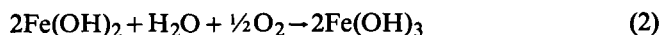

This trivalent iron hydroxide is the compound most commonly deposited onto the metal surface.

The cathodic reactions on the surface of the iron are several:



This is a net reaction which goes through several steps and can leave a series of products on the surface such as absorbed H and adsorbed H_2 (products of activation polarization).



The hydroxide ions then react with Fe^{++} in solution to form the $\text{Fe}(\text{OH})_2$ directly at the surface instead of precipitating out of solution and then may oxidize.

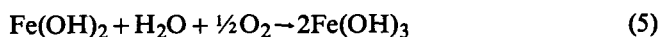

Furthermore, $\text{Fe}(\text{OH})_2$ can lose some of its directly bonded OH^- to form $\text{FeO} \cdot \text{H}_2\text{O}$ even at room temperature where FeO itself is unstable. Commonly, $\text{Fe}(\text{OH})_3$ changes into $\text{Fe}_2\text{O}_3 \cdot \text{H}_2\text{O}$. Combinations of $\text{Fe}(\text{OH})_2$ and $\text{Fe}(\text{OH})_3$ can form Fe_3O_4 . An additional effect is the direct dissolution of $\text{Fe}(\text{OH})_2$. Also, an additional reaction product can come about from difficulties of direct solution of Fe^{+++} . It is thought to redissolve as an oxygen complex, react in a quasi double-layer process, and

reprecipitate as colloidal FeOOH (ref. 14). This solid may then collect on the metal surface or remain in suspension to give a reddish color to the solution.

The oxide, Fe_2O_3 , may form in solution from Fe^{++} ions which have been oxidized to Fe^{+++} plus oxygen in solution, then, when exceeding their solubility limit, deposit in the loosely adhering hydroxide layer. On the other hand, it can form directly on the surface as one of the cathodic reactions. If conditions are right, this surface-formed oxide can be continuous. It is then an insulating film which protects the iron from further corrosion by passivation.

Thus, the corrosion reaction products on the surface of iron are generally stated to be a complex mixture of hydroxides and hydrated oxides.

Figure 16 shows that divalent iron in $\text{Fe}(\text{OH})_2$ has a strong tendency to dissolve when the pH is below about 10, i.e., about 10^{-4} N NaOH. Thus, even if the iron were not entirely oxidized to a trivalent form, the divalent iron compounds would tend to be minimized by solution or by failure to precipitate onto the iron surface. This is significant in the results of XPS analyses in previous work (refs. 7 and 8), but was not discussed in those publications.

Figure 16 shows that, while $\text{Fe}(\text{OH})_2$ is highly soluble below a pH of about 10, $\text{Fe}(\text{OH})_3$ is virtually insoluble down to a pH of about 6. Thus, $\text{Fe}(\text{OH})_3$ is likely to deposit from solution and form a thick, loosely adhering, friable surface layer in dilute acids. The significance of this is discussed in explaining high friction and high wear in some experiments where the sulfuric acid is very dilute, around 10^{-4} N (pH=4) which is around 5 parts per million by weight.

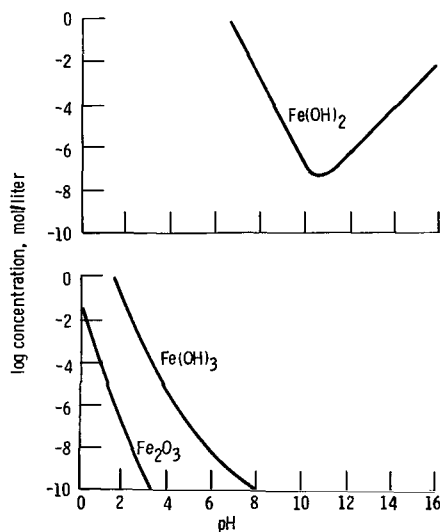

Figure 16. — Influence of pH on the solubility of $\text{Fe}(\text{OH})_2$, $\text{Fe}(\text{OH})_3$, and Fe_2O_3 (ref. 12).

References

1. Eyre, T. S.: Wear Characteristics of Metals. Source Book on Wear Control Technology. D. A. Rigney and W. A. Glaeser, eds., American Society for Metals, 1978, pp. 1-10. (Originally in Tribol. Int., vol. 9, no. 5, Oct. 1976, pp. 203-212.)
2. Neale, M. J., ed.: Tribology Handbook. Butterworths (London), 1973 (Section on Lubricants).
3. Waterhouse, R. B.: Fretting in Hostile Environments. Source Book on Wear Control Technology, D. A. Rigney and W. A. Glaeser, eds., American Society for Metals, 1978, pp. 261-269. (Originally presented at the 3rd Tribology Conf., Tribology for the Eighties, Paisley, Scotland, Sept. 22-25, 1975. See also Wear, vol. 34, 1975, pp. 301-309.)
4. Bowden, F. P.; and Tabor, D.: The Friction and Lubrication of Solids. Oxford University Press (London), 1950 (with corrections through 1971).
5. Rabinowicz, Ernest: Friction and Wear of Materials. John Wiley and Sons, Inc., 1965.
6. Staehle, R. W.: Stress Corrosion Cracking (and Corrosion Fatigue). Mater. Sci. Eng., vol. 25, Sept.-Oct. 1976, pp. 207-215.
7. Rengstorff, G. W. P.; Miyoshi, K.; and Buckley, D. H.: Friction and Wear of Iron in Corrosive Media. NASA TP-1985, 1982.
8. Rengstorff, G. W. P.; Miyoshi, K.; and Buckley, D. H.: Friction and Wear of Iron and Nickel in Sodium Hydroxide Solutions. ASLE Trans., vol. 26, no. 4, Oct., 1983, pp. 509-516.
9. Rengstorff, G. W. P.; Miyoshi, K.; and Buckley, D. H.: Friction and Wear of Nickel in Sulfuric Acid. NASA TP-2290, 1984.
10. Fontana, Mars G.; and Greene, Norbert D.: Corrosion Engineering. Second ed., McGraw-Hill Book Co., Inc., 1978.
11. Wiley, H. H.: Corrosion and Corrosion Control, Second ed., John Wiley and Sons, Inc., 1971.
12. Pourbaix, M.: Atlas of Electrochemical Equilibria in Aqueous Solutions. Second English Ed., National Association of Corrosion Engineers, 1974.
13. Tomashov, N. D.: Theory of Corrosion and Protection of Metals. Translated and edited by B. H. Tytell, I. Geld, and H. S. Preiser, The Macmillan Co., 1966.
14. Hauffe, K.: Oxidation of Metals. Plenum Press, 1965.
15. Producers Handbook; Huntington Alloys, Resistance to Corrosion. The International Nickel Co., Inc., 1965, revised 1970.
16. Approximate pH Values, CRC Handbook of Chemistry and Physics, 63rd Edition, CRC Press, Inc., 1982, p. D-156.

1. Report No. NASA TP-2289		2. Government Accession No.		3. Recipient's Catalog No.	
4. Title and Subtitle Friction and Wear of Iron in Sulfuric Acid				5. Report Date April 1984	
7. Author(s) George W. P. Rengstorff, Kazuhisa Miyoshi, and Donald H. Buckley				6. Performing Organization Code	
9. Performing Organization Name and Address National Aeronautics and Space Administration Lewis Research Center Cleveland, Ohio 44135				8. Performing Organization Report No. E-1635	
12. Sponsoring Agency Name and Address National Aeronautics and Space Administration Washington, D.C. 20546				10. Work Unit No.	
15. Supplementary Notes George W. P. Rengstorff, University of Toledo, Toledo, Ohio (work done under NASA grant NAG3-276); Kazuhisa Miyoshi and Donald H. Buckley, Lewis Research Center.				11. Contract or Grant No.	
16. Abstract Friction and wear experiments were conducted with elemental iron sliding on aluminum oxide in aerated sulfuric acid concentrations ranging from very dilute (0.7×10^{-4} N; i.e., 4 ppm) to very concentrated (96 percent acid). Load and reciprocating sliding speeds were kept constant. With the most dilute acid of 0.7 to 2×10^{-4} N, a complex corrosion product formed that was friable and often increased friction and wear. At slightly higher concentrations of 0.001 N, metal losses were essentially by wear alone. Because no buildup of corrosion products occurred, this acid concentration became the standard from which to separate metal loss from direct corrosion and mechanical wear losses. When the acid concentration was increased to 5 percent, the well-established high corrosion rate of iron in sulfuric acid strongly dominated the total wear loss. This strong corrosion increased to 30 percent acid, and decreased somewhat at 50 percent in accordance with expectations. However, the low corrosion of iron expected at acid concentrations of 65 to 96 percent was not observed in the wear area. It is apparent that the normal passivating film was being worn away and a galvanic cell established which rapidly attached to the wear area. Under the conditions where direct corrosion losses were highest, the coefficient of friction appeared to be the lowest.				13. Type of Report and Period Covered Technical Paper	
17. Key Words (Suggested by Author(s)) Tribology		14. Sponsoring Agency Code			
18. Distribution Statement Unclassified - unlimited STAR Category 26		19. Security Classif. (of this report) Unclassified			
20. Security Classif. (of this page) Unclassified		21. No. of pages 21		22. Price* A02	

National Aeronautics and
Space Administration

Washington, D.C.
20546

Official Business

Penalty for Private Use, \$300

THIRD-CLASS BULK RATE

Postage and Fees Paid
National Aeronautics and
Space Administration
NASA-451



7 1 1U,C, 840417 500903DS
DEPT OF THE AIR FORCE
AF WEAPONS LABORATORY
ATTN: TECHNICAL LIBRARY (SUL)
KIRTLAND AFB NM 87116

NASA

POSTMASTER: If Undeliverable (Section 158
Postal Manual) Do Not Return