

**NASA
Technical
Paper
2290**

C.2

April 1984

Friction and Wear of Nickel in Sulfuric Acid

George W. P. Rengstorff,
Kazuhisa Miyoshi,
and Donald H. Buckley

Property of U. S. Air Force
AEDC LIBRARY
F40600-81-C-0004

**TECHNICAL REPORTS
FILE COPY**

NASA

NASA
Technical
Paper
2290

1984

Friction and Wear of Nickel in Sulfuric Acid

George W. P. Rengstorff

University of Toledo
Toledo, Ohio

Kazuhisa Miyoshi
and Donald H. Buckley

Lewis Research Center
Cleveland, Ohio

NASA

National Aeronautics
and Space Administration

Scientific and Technical
Information Branch

Summary

A fundamental investigation was conducted to determine the interaction of the corrosive medium, sulfuric acid, and nickel during sliding friction and wear experiments. A nickel pin specimen with a tip radius of 3.2 millimeters was made to slide across an aluminum oxide surface in reciprocating motion at a relatively slow speed of 9 centimeters per minute under a load of 2.5 newtons. The aerated sulfuric acid ranged from a very dilute 10^{-4} N (5 ppm) to a highly concentrated 96 percent ($35\frac{1}{2}$ N).

In the most dilute acid there was no observable corrosion either in the wear area or on the surrounding nickel. The amount of nickel lost in wear under this condition became the basis of comparison by which to determine the amount of wear loss due to corrosion at the various acid concentrations.

A notable result of the experiments was that metal lost by corrosion was a large share of the total metal loss in the wear area at acid concentrations between 0.5 percent (0.1 N) and 75 percent (25 N). The rapid corrosion in the wear area was clearly induced by the wear process. Scanning electron micrograph SEM studies showed little or no corrosion in the nickel outside the wear area. This low general corrosion rate of nickel in aerated sulfuric acid is in agreement with published corrosion rates for nickel. At the same time, the corrosion rates within the wear area were very high, up to 100 millimeters per year at 30 percent acid. Actually, the rates were as high or higher than those for iron, a metal notorious for its lack of corrosion resistance at intermediate sulfuric acid concentrations.

It is clear that corrosion in a wear area was greatly accelerated by the wear process. The mechanical wear must have worn away the protective film that normally forms on nickel in sulfuric acid. Then the wear area must have become anodic to its low-corrosion surroundings. Thus, metal loss in the wear area was greatly increased by the formation of a galvanic couple with the surroundings. However, at acid concentrations of 96 percent, corrosion loss in the wear area again became small. It is concluded that the protective film redeveloped in the concentrated, aerated acid as fast as it was removed.

At two dilute concentrations, 0.001 N (0.005 percent) and 0.01 N (0.05 percent), corrosion loss in the wear area was low. However, there was small corrosion locally out-

side the wear area in the direction of sliding. This is attributed to fluid motion in the acid.

Introduction

The fact that corrosion can add to metal loss in the friction and wear of metals is well recognized. However, it is not well understood that simply adding normal corrosion loss to mechanical wear loss does not necessarily add up to total wear when the wear is occurring under corrosive conditions. The total wear loss may be a great deal higher or lower than the sum of corrosive and mechanical wear.

The interaction of the two processes (mechanical and corrosive) often comes from the fact that both are sensitive to surfaces. If mechanical rubbing removes the protective film on a metal being worked in a corrosive environment, overall metal loss due to wear may be greatly increased. If corrosion develops a deposit which breaks up and is easily removed, the overall metal loss in wear is increased. Further, if the corrosion process continuously creates a protective film, mechanical wear is decreased.

Another important factor is that metal in an active wear area is different from the surrounding metal. In the wear area the metal is undergoing high and cyclic elastic and plastic strains. It is becoming cold worked. Local high temperatures are being created at make-and-break contact points. All of this means that the metal in the wear area is chemically different from the surrounding metal. This chemical difference sets up conditions for galvanic coupling of the wear spot and the surrounding metal surfaces. Because the mechanical effects plus removal of surface films make the wear area more active electrochemically, the wear area usually would be corroded faster than if there were no wear. This aggravation of metal loss by wear in corrosive media has been observed often in the study of wear-corrosion interactions.

This paper, with its subject the wear of nickel in sulfuric acid, is part of that study. A companion report on the wear of iron in sulfuric acid (ref. 1) shows wear increasing the corrosion rate in concentrated sulfuric acid, deposition of corrosion products increasing losses due to mechanical wear at very dilute acid, and a simple additive effect with a dominance of corrosion losses at in-

intermediate acid concentration. On the other hand, overall wear losses are sharply reduced by concentrated sodium hydroxide, presumably by formation of a low friction surface under low corrosion conditions (refs. 2 and 3).

Materials

The nickel was electrolytic and was annealed to a Rockwell B hardness of 30 after machining. The sulfuric acid was ACS reagent grade concentrated acid. The water used to make the solutions was deionized, distilled, and saturated with room temperature air.

The reagent grade sulfuric acid may contain 95.5 to 96.5 percent acid; it is referred to herein as 96 percent.

Apparatus

Each bullet-shaped, 6.4-millimeter (1/4-in.) diameter nickel rider used had a tip radius of 3.2 millimeters (1/8 in.) and was 16 millimeters (5/8 in.) long overall. The riders were mounted in a holder and slid over aluminum oxide (sapphire) flats. These sliding experiments differed from our previously reported research (refs. 2 and 3) in which a sapphire ball rider was moved over a flat metal specimen.

The friction apparatus is shown schematically in figure 1. The aluminum oxide flats were attached to the bottom of glass cups (fig. 2). In operation the cups were filled with the acid to about 3 millimeters above the surface

of the flats. A metal cylinder was attached to the bottom of the cups so they could be held in a vise and reciprocated under the metal slider during the experiment. The cups were the bottom sections cut from 30-milliliter heat resistant beakers.

Epoxy cement was used to attach the aluminum oxide flats to the inside bottom of the cups. A general-purpose epoxy cement was serviceable through 65 percent sulfuric acid. A high-density epoxy cement designed for high-vacuum environments withstood the 75 percent sulfuric acid solution. For the 95 percent acid solution a similar cup out of polytetrafluoroethylene (PTFE) was made. A groove was cut into the bottom inside the cup. The aluminum oxide flat fit tightly in the groove so that a cement was not needed. The bottom cylinder for holding the cup in the vise was machined from the same piece of material as the cup itself.

As indicated in figure 1 the flats were moved back and forth under the loaded nickel rider. The motion of the flats was 1 centimeter in each direction. The wear motion was variable and shorter because of drag. The rider load was 250 grams. The arm holding the rider was flexible, so the friction force F could be measured with calibrated strain gages and continuously recorded.

There were nine reversals per minute, that is, the aluminum oxide flat travelled at an average speed of 9 centimeters per minute. Each experiment lasted 60 minutes. Thus, the rider passed over the flat 540 times (270 times each way) during an experiment. The experiments were carried out in air, so the acid was standardized in the aerated condition.

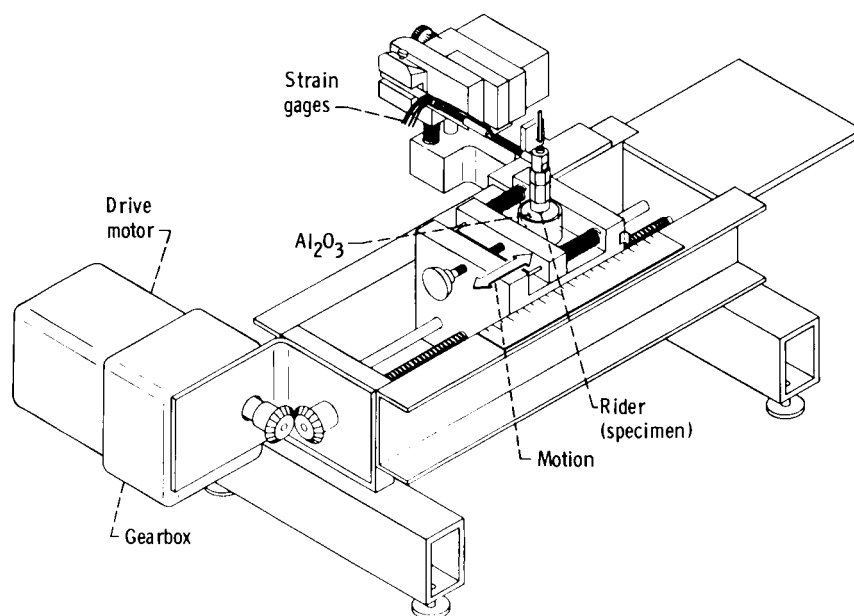

Figure 1. - Friction and wear apparatus.

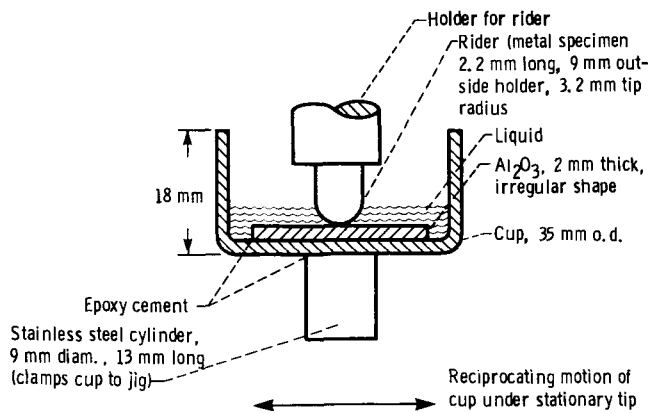

Figure 2. — Details of rider, Al_2O_3 surface, and cup for liquid.

Experimental Procedure

The hemispherical tips of the nickel riders were polished with 6- and 3-micrometer diamond paste. Finish polishing was with a wet metallographic polishing cloth impregnated with 0.3-micrometer α -aluminum oxide. The specimen was rotated in a small lathe for the polishing operation. Afterward, the polished tip was washed thoroughly, using a cotton swab to help remove the polishing powder.

The aluminum oxide flats in their cups were clamped in the jig. The nickel specimens (riders) in their holders were lowered to a few millimeters above the flats, and alignments were checked. Then the acid was dropped into the cups to cover the flats to the proper depth. Thereafter, the riders were lowered until the tips touched the flats, the 2.5-newton (250-g) load installed, and the experiment started.

The friction force F of the rider moving across the flat was determined by strain gages on the flexible arm that held the loaded rider. The output from the calibrated strain gages was recorded continuously. The coefficient of friction, then, was the force divided by the load of the rider (2.5 N; 250 g). The static coefficient μ_s was calculated from the maximum F in each direction of travel or, as used, half the maximum force in a complete reversal of travel. The kinetic coefficient was estimated in the usual manner by using the force as the mean between the maximum force (stick) and the minimum force (slip) when stick-slip occurred.

The amount of metal lost in wear was determined by measuring the size of the wear spot on the tip after an experiment. The wear spot was photographed at a nominal magnification of 100. The maximum length of the spot, which occurred in the direction of motion, and the minimum length of the wear spot were measured on the photographic print. These were converted to true size using the correct magnification as determined by calibration. Then the amount of metal that would have been removed with a circular spot of the minimum length of the observed spot was calculated. The same calculation

was made assuming that the wear spot had a diameter equal to its longer dimension. The two volumes were averaged to give an estimate of the amount of metal lost during the experiment. The volumes were calculated using the equation:

$$V = \frac{\pi}{3} [2R^3 - (2R^2 + r^2)\sqrt{R^2 - r^2}]$$

where

R radius of tip (3.2 mm, 1/8 in.), which for calculation was used as constant 3.1750064 millimeters

r radius of circular spot

The volume was calculated as 10^{-5} cubic millimeter and reported and used to one, or at most, two significant figures.

Estimation of Direct Corrosion Contribution to Metal Lost

A corrosive solution can influence metal loss in wear several ways. In particular, corrosion overall or selectively in the wear area might remove metal in addition to mechanical phenomenon. When direct corrosion loss is great enough, it is possible to estimate corrosion rates in the wear area. Comparison with published corrosion rates, together with a comparison of the corrosion pattern in the wear zone with the pattern outside the wear zone, provides some insight into the interaction of the corrosive solution and total wear losses.

The basic procedure for estimating corrosion rates in the wear zone was as follows:

(1) As a base, the wear spot diameter was used to calculate volume of metal loss under conditions where the corrosive solution did not directly cause the loss. For nickel, this base was the spot diameter of 0.24 millimeter and total loss of 5×10^{-5} cubic millimeter obtained with 10^{-4} N sulfuric acid.

(2) The total volume of metal lost due to the combined normal friction and corrosion effect was measured for each experimental condition. The volume lost under the base condition was subtracted from this to give the volume lost by corrosion.

(3) The average wear spot diameter for the solution under consideration and for the base condition gives the diameter of a cylinder of metal lost by corrosion. Using this and the volume obtained in item (2) allow a calculation of the height of the cylinder. This height is the corrosion penetration in an hour. From it can be calculated the corrosion rate in millimeters per year and mpy.¹ The rates

¹The unit of mpy (mils per year) has been standard for penetration in corrosion literature. It is numerically similar to the true SI unit for which 1 mpy = 0.805 picometer per second (ref. 5).

in millimeter per year are given to the nearest calculated whole numbers; the rates in mpy were rounded off to the nearest hundred, which is slightly more realistic but which probably indicates an accuracy greater than justified by the data. The greatest cause of uncertainty comes from volume and average diameter errors due to the fact that the wear spots are not round. A further contributor to uncertainty is that the wear spots are not flat, as assumed in the calculations.

The effect of the assumption that corrosion has no effect on tip radius is minor. In fact, under the conditions of these experiments, the change in tip radius resulting from overall corrosion would give an undetectable difference from having all the corrosion localized in the wear spot.

Errors from the fact that the tip has a curved surface and that the corrosion calculation is based on a cylinder of average diameter are insignificant. The problem of choosing the base wear conditions appear to be far overshadowed by uncertainties in volume and average diameter. Another questionable procedure is the comparison of 1-hour corrosion rates with published data, which were usually obtained over a much longer time. The general conclusion, however, is that these estimated corrosion rates are valuable supplements to other information about the wear-corrosion process.

Another limitation of the estimation process is its inability to detect low corrosion rates. A corrosion rate of over 5 millimeters per year (200 mpy) is considered unacceptable for iron- or nickel-base alloys (ref. 5). Yet this rate would only change the diameter of a 0.24-millimeter wear spot to 0.26-millimeter; both of these values are within the observable scatter band. Actually, the 7-millimeter-per-year (300-mpy) rate used as the detection limit in the tabulation is somewhat optimistic.

Results and Discussion

Table I shows the published corrosion rates of nickel in aerated sulfuric acid over most of the concentration range (ref. 4). Note that for the rates between 0.3 and 1.5 millimeter per year (10 to 61 mpy), nickel corrosion is in the range of 0.1 to 0.5 millimeter per year, which is considered to be good, 0.5 to 1 millimeter per year, which is fair, and 1 to 5 millimeters per year, which is poor. Still, the corrosion rate is low compared with the high rates observed for the wear area in aerated sulfuric acid concentrations of 0.1 N (0.5 percent) and above.

Figure 3 presents the friction and wear data for the dilute acid range (to 1.0 N (5 percent)). The lowest corrosion induced wear loss occurred at 10^{-4} N (5 ppm), the most dilute acid.

The SEM (scanning electron microscope) was used to study a tip worn in 10^{-4} N acid (no figure shown). The

TABLE I. - CORROSION TESTS OF NICKEL IN AERATED SULFURIC ACID AT 303 K (86° F)(REF. 4)

Acid concentration, wt %	Corrosion rate	
	mm/yr	mpy
1	1.2	49
5	1.5	61
50	.4	16
93	.3	10

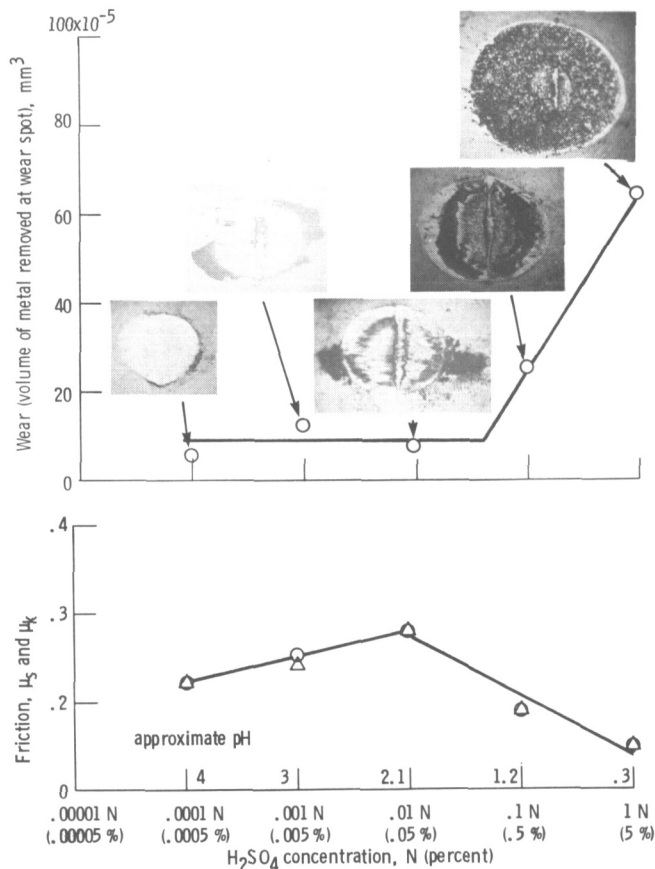

Figure 3. - Friction and wear of nickel worked in dilute sulfuric acid.

structure was featureless both inside the wear spot and in the surrounding areas. It is apparent that the nickel was not attacked by this dilute acid in the wear area or outside. Furthermore, no corrosion product formed on the wear surface to cause an increase in friction and mechanical wear loss, as occurred with iron in the same dilute acid (ref. 1). Thus, the wear in 10^{-4} N acid was taken as the base from which to determine the amount of corrosion-caused metal loss. The results of this analysis are given in table II.

At 0.001 N the metal loss in the wear spot was low (fig. 3 and table II). The photomicrograph shows little structural variation in the spot itself and only slight

TABLE II. - CORROSION RATES FOR WEAR SPOTS OF NICKEL TIPS IN SULFURIC ACID

H ₂ SO ₄ concentration	Corrosion rate	
	mm/yr	mpy
10 ⁻⁴ N (0.005 percent)	^a 0	^a 0
0.001 N (0.005 percent)	11	400
0.01 N (0.05 percent)	<7	>300
0.1 N (0.5 percent)	26	1000
1 N (5 percent)	56	2300
30 percent (7½ N)	100	4000
50 percent (15 N)	31	1200
65 percent (21 N)	16	600
75 percent (25 N)	21	800
96 percent (35½ N)	<6	<300

^aCalculation base.

darkening of the metal outside the wear area in the direction of sliding; so an SEM study was not undertaken.

At 0.01 N acid the metal loss, within the limitation of measurement, was about as low as at 0.0001 N and perhaps a little lower than that at 0.001 N (fig. 3, table II); the coefficient of friction is a little higher. However, the photomicrograph shows that the wear spot and some of its surroundings are unusual.

The SEM photographs of figures 4(a) to (c) show more clearly the wide variety of surface structures found inside the wear area. In addition to the variations within the wear area, the photomicrographs in figures 3 and 4 show a darkened region extending some distance from the wear spot in the direction of the reciprocal motion. Figure 4(d), taken in this darkened region just outside the wear spot, shows a strong corrosion pattern. Figure 4(e), taken further away, shows what appears to be an even deeper irregular corrosion penetration. Thus, while metal loss measured by wear spot diameter alone shows only a small increase over 10⁻⁴ N, actual metal loss is much greater due to corrosion resulting from fluid motion. Well outside the wear spot, the surface has an uncorroded structure (not shown). It appears that the smaller, darkened area outside the wear area in the specimen obtained in 0.001 N acid has a similar appearance but quantitatively less. Note that this corrosion effect outside the wear area was not observed with acid concentrations above 0.01 N.

For the sulfuric acid concentration of 0.1 N, the amount of metal lost in the wear-corrosion process was three times the total loss in more dilute acid. Table II indicates the corrosion rate to be a high 26 millimeters per year (100 mpy). The uneven structures observed in the SEM's of figures 5(a) and (b) are further evidence of active corrosion during wear. These findings foreshadow the much more active corrosion at 1.0 N acid. The smooth region in the wear area (fig. 5(c)) reveals that corrosion was still irregular at 0.1 N acid.

At 1.0 N (5 percent) around 7 or 8 times as much metal was lost in the wear spot than at 0.01 N or less. At the same time the coefficient of friction was appreciably lower, so adhesion and other direct wear effects are not the cause of these losses. It must be the corrosion effect.

The SEM structure outside the wear area (fig. 4(c)) shows that overall corrosion of the nickel was low. This is in agreement with the published results in table I (ref. 4) which show that, while corrosion rates in aerated sulfuric acid do vary somewhat with concentration, they are never outstandingly high. Supporting evidence of this is figure 6(c), which shows that the corrosion was not great enough to remove the polishing scratches or bring out the grain structure.

Corrosion inside the wear area, however, was rapid enough to give a strongly faceted corrosion surface (fig. 6(b)). The great difference in corrosion rates inside and outside the wear zone could conceivably be simply the wear-induced removal of a protective surface on the nickel. More likely, though, it is because of the establishment of a galvanic cell between the wear spot and its surroundings. The wear spot became the anode where nickel rapidly dissolved; the surroundings became the cathode, did not corrode, and might also have been given extra protection.

The reciprocating motion of the wear leads to an observable centerline pattern in most specimens. This pattern is perpendicular to the direction of the wear motion. In some specimens SEM reveals that this zone is really no different from the surroundings. However, figure 6(a) indicates that a comparatively deep labyrinth corrosion pattern developed at 1.0 N sulfuric acid.

Figure 7 shows the friction and wear of nickel tips operating in sulfuric acid in concentrations of 30 to 96 percent acid. Included for comparison are the data for 5 percent (1.0 N) acid from figure 3.

The total amount of metal lost in wear, which had started to climb at a little less than 0.5 percent (0.1 N) sulfuric acid, continued to climb as the concentration increased to 30 percent (7½ N). Between 30 and 50 percent (7½ and 15 N) acid, metal lost in the wear area dropped to 30 × 10⁻⁵ cubic millimeter—not much different from the 26 × 10⁻⁵ cubic millimeter observed for 0.5 percent (0.1 N). At 65 and 75 percent acid (21 and 25 N), the wear dropped further, but did not reach the low values of 0.01, 0.001, and 10⁻⁴ N. At 96 percent acid (35½ N), the wear loss did essentially drop to that of the very dilute acids.

At the low acid concentrations (1.0 N and less), there was little or no slip-stick, so that very little difference existed between static and dynamic friction. At 30 percent acid and above sliding changed so there is an appreciable difference between μ_s and μ_k .

Figures 3 and 7 show that μ_s varied between 0.15 and 0.28 with acid concentration. It is, however, difficult to draw conclusions from the observed variations.

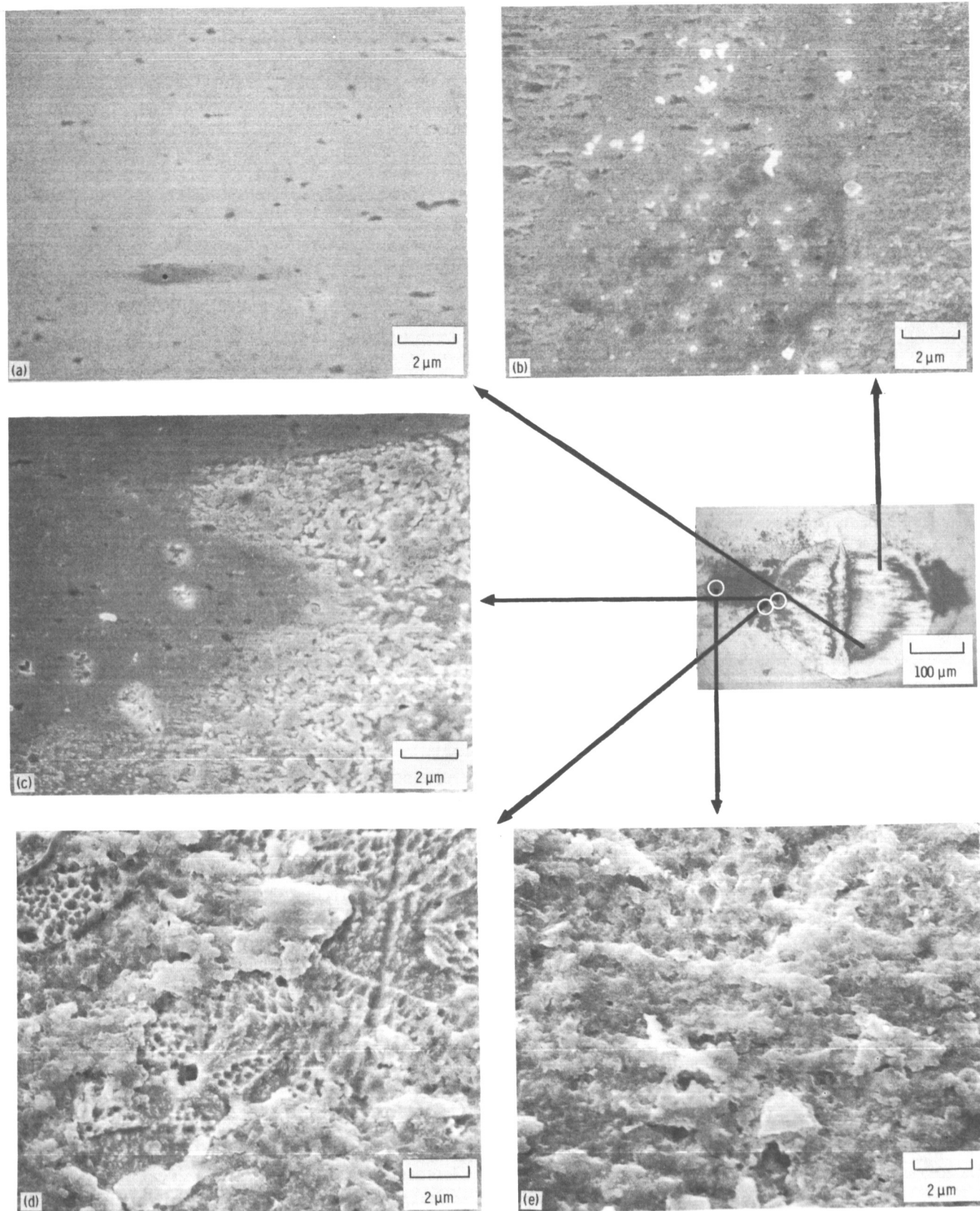

Figure 4. - Wear spot and adjacent area of a nickel tip worked in 0.01 N sulfuric acid. SEM photograph locations are as shown in the photomicrograph.

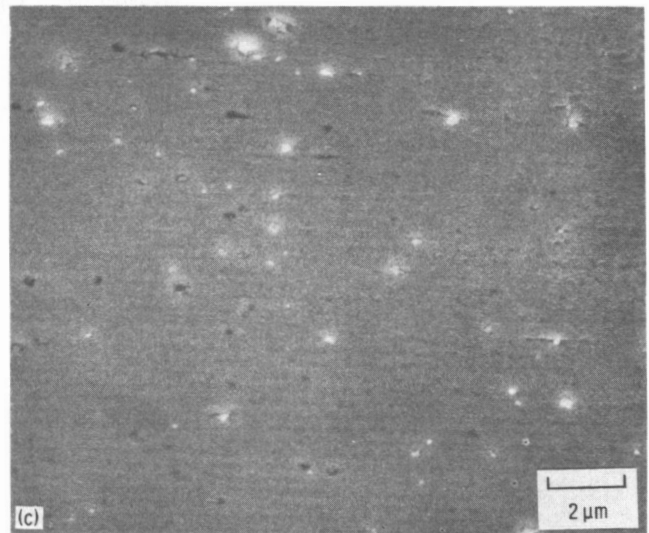
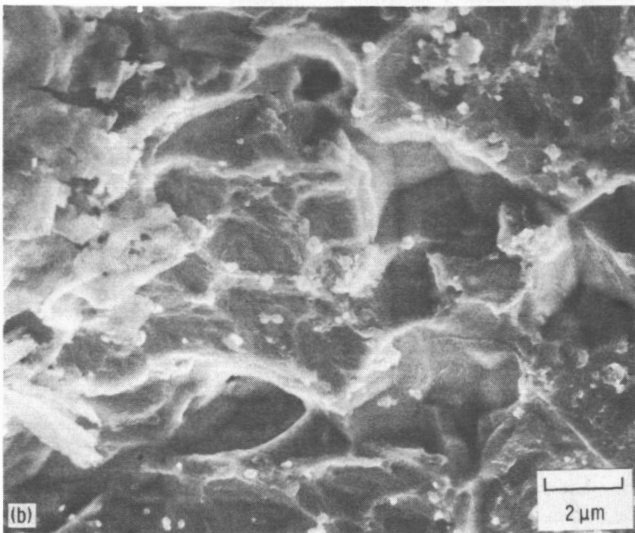
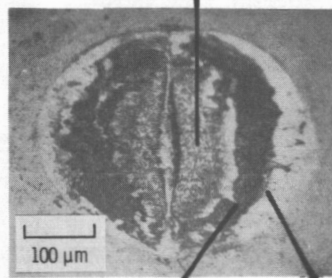
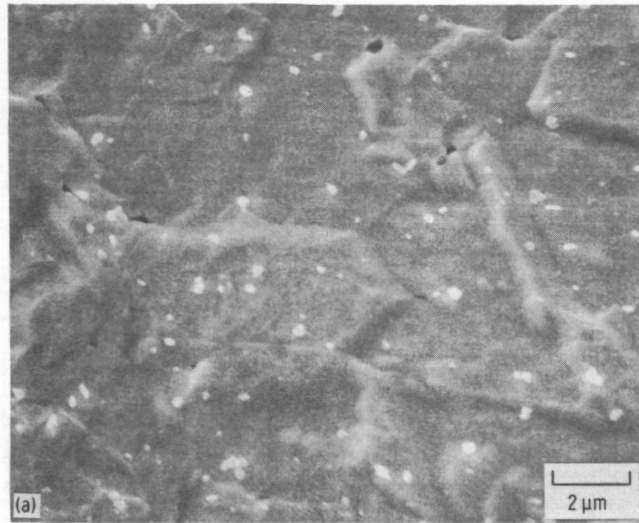

Figure 5. - Wear area of a nickel tip worked in 0.1 N sulfuric acid. SEM photograph locations are as shown in the photomicrograph.

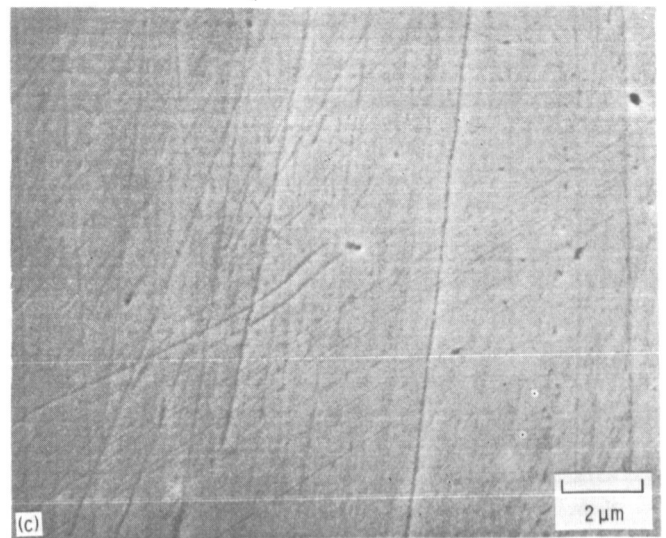
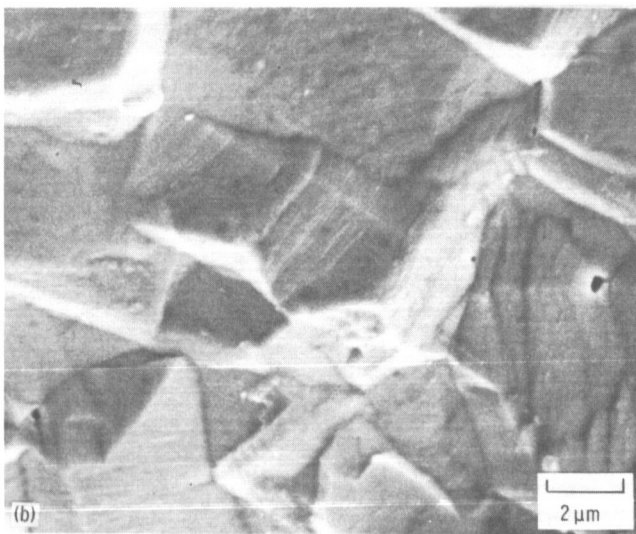
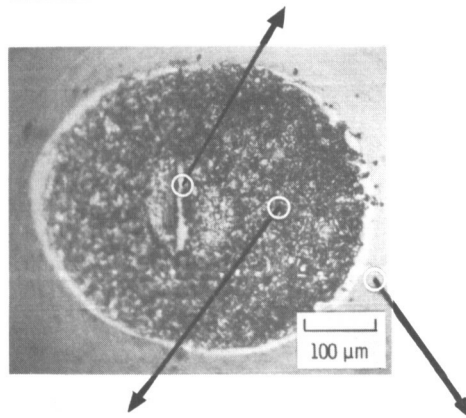
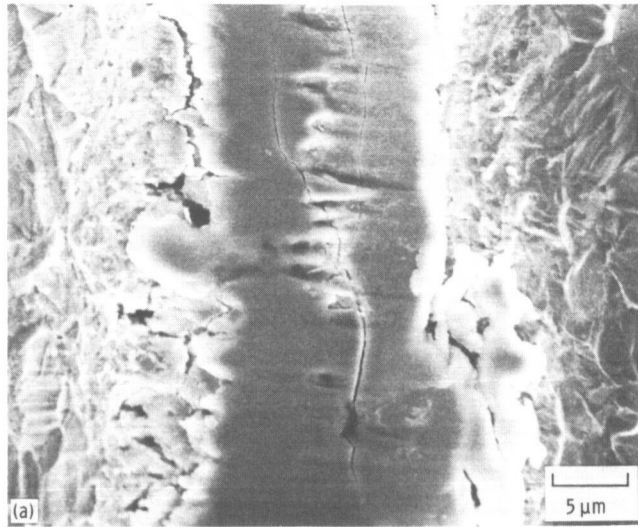

Figure 6. – Wear area of a nickel tip worked in 1.0 N sulfuric acid. SEM photograph locations are as shown in the photomicrograph.

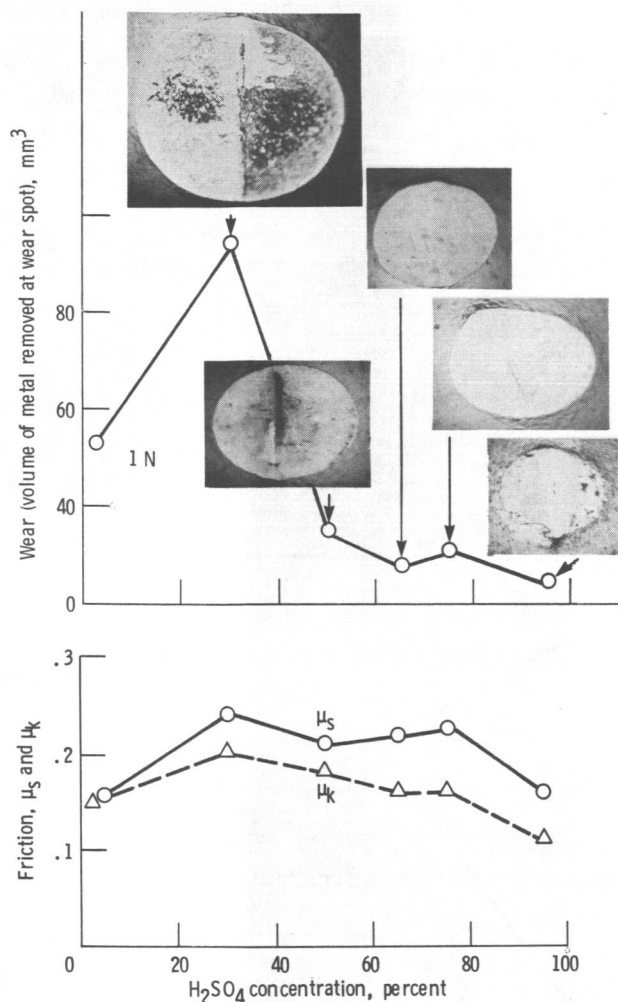

Figure 7. - Friction and wear of nickel in concentrated sulfuric acid.

Figures 8(a) and (b) present two extremes of wear/corrosion patterns developed in the interior of the wear spot at 30 percent acid. Both the deeply faceted pattern of 8(a) and the relatively smooth pattern of 8(b) cover large proportions of the wear spot. Figure 8(c) shows still another region inside the wear spot. This is the structure in what appears as a bright rim in the photomicrograph. Note that all these patterns exist at the acid concentration where wear and corrosion interact to give the greatest metal loss. Corrosion has greatly enhanced the wear; likewise, wear has greatly enhanced corrosion.

Figure 8(d) indicates that just outside the wear spot, a small amount of corrosion has occurred. Grain boundaries have just barely become visible. There is a little pitting in these grain boundaries. Figure 8(e) reveals a small amount of pitting well outside the wear area. This had not been observed at lower concentration of acid. However, a little general corrosion of nickel is consistent with the published corrosion values (see table I).

Figure 9 indicates that the metal lost in the wear experiment was much less at 50 percent acid than at 30 percent

acid. According to reference 4, the corrosion rate of nickel at 50 percent acid is appreciably lower than at 5 percent acid. The SEM photographs in figure 9 reflect this trend.

A comparison of figures 9 with 8 shows the differing behavior of the 50 (fig. 9) and 30 (fig. 8) percent solutions. The rough, clearly corroded regions are in much less relief in figure 9(a) than in figure 8(a). The smooth regions have less feature in figure 9(b) than in 8(b). Figure 9(d) shows less pitting outside the wear spot than do figures 8(d) and (e) and no etching. There is less attack just inside the wear area at 50 percent acid (fig. 9(d)) than at 30 percent acid (fig. 8(d)).

The corrosion contribution to the wear spot is only about one-fourth as great at 50 percent acid as at 30 percent acid, and only about one-half as great at 50 percent acid as at 5 percent (1 N). Putting all of the information together suggests that a passivation film or polarization product, which slows down the overall corrosion rate of nickel in aerated sulfuric acid, is forming fast enough to slightly protect the wear area as well, but not fast enough to provide full protection. As part of this, the wear area is presumably less anodic with respect to its surroundings, so the amount of galvanic cell corrosion is reduced.

At 65 and 75 percent acid, the wear losses are still lower than at 50 percent acid (fig. 7). Figure 10(a) indicates a smooth surface throughout the wear area at 65 percent acid. There are no rough, highly corroded areas in the wear spot, as observed in all specimens studied at concentrations between 0.05 percent (0.01 N) and 50 percent acid. At both 65 and 75 percent acid, the direct corrosion contribution to wear is an important part of metal loss but is appreciably reduced (table II). It appears that passivation or polarization layers are being formed almost as fast as they can be worn away.

Figure 7 indicates that wear in this 96 percent acid is, within the accuracy of measurement, back to that of the very dilute 10^{-4} N acid. The data differ from the data for the dilute acid in that the static coefficient of friction μ_s is lower in the concentrated acid (0.16 compared with 0.22). A large amount of stick-slip in the concentrated acid brings μ_k down to 0.11 compared with 0.22.

The SEM pictures of figure 11 show the specimen worn in the 96 percent acid. It shows corrosion-induced roughening in the nickel outside the wear spot (figs. 11(b) and (c)). The wear spot itself is not as smooth as it was at 10^{-4} N acid and perhaps not as smooth at 65 percent acid. However, all of the information combined leads to the conclusion that a poorly conducting (passivating) film forms rapidly in the wear area and also on the nickel outside the wear spot. Consistent with this (but not proof) is the difficulty of obtaining well-focused SEM photographs at magnifications above 2000, inasmuch as the specimens had not been coated with an electrically conducting film.

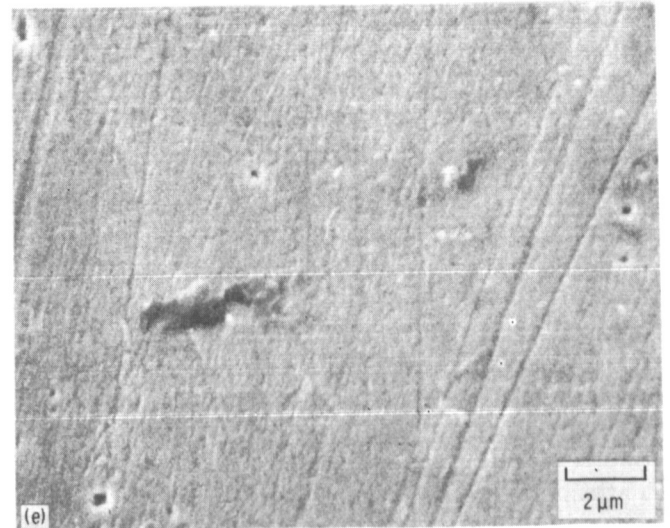
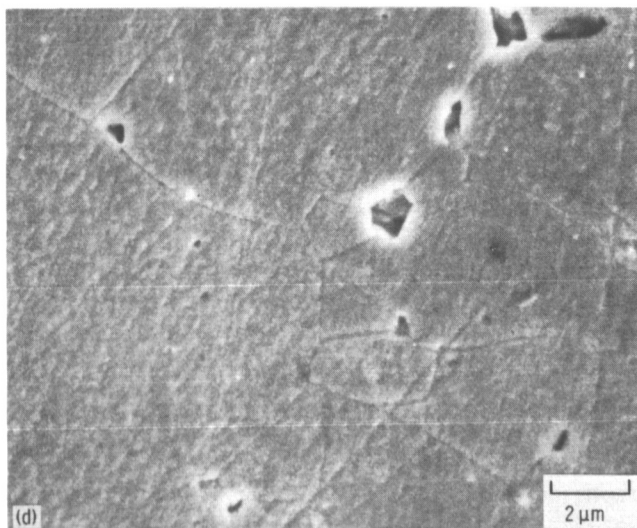
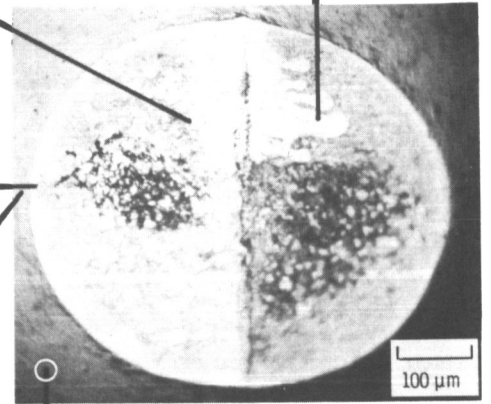
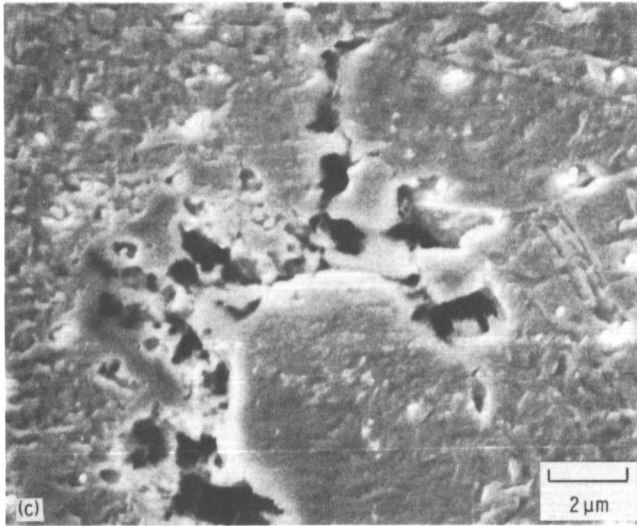
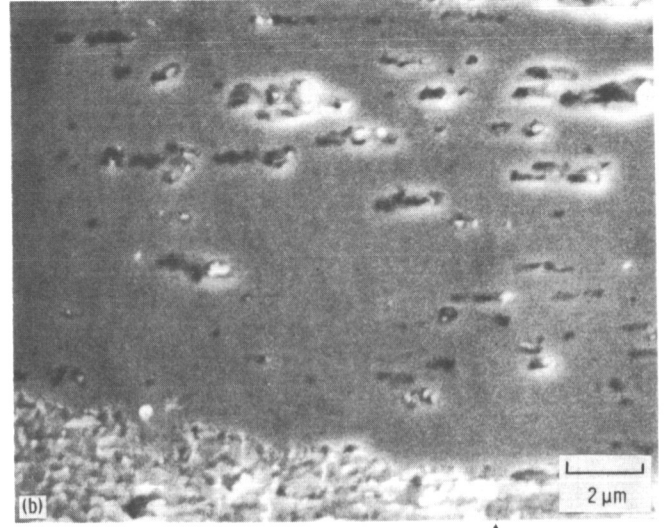
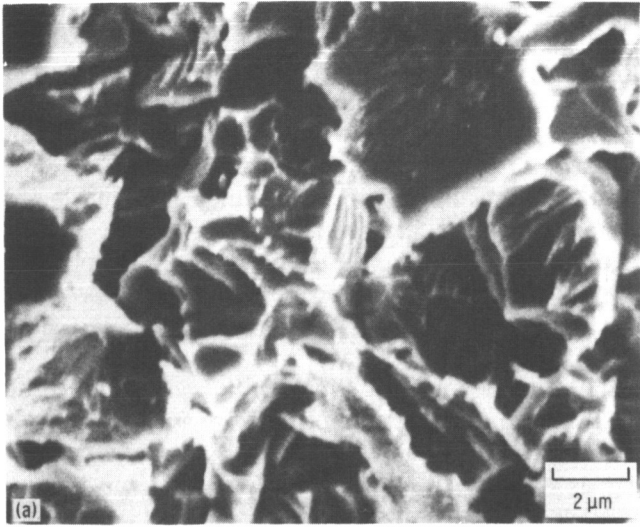

Figure 8. - Wear area and surroundings of a nickel tip worked in 30 percent sulfuric acid. SEM photograph locations are as shown in the photomicrograph.

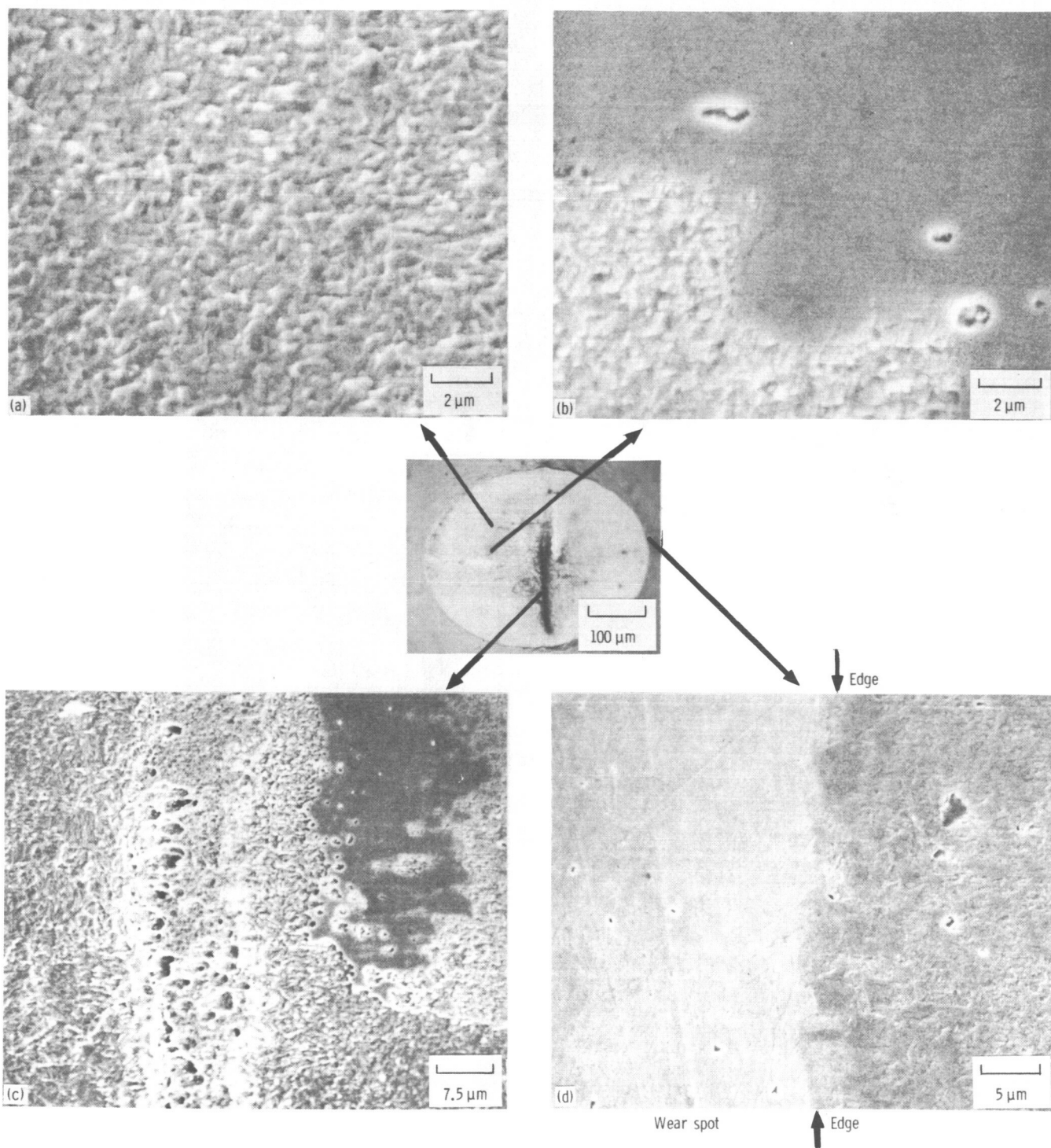

Figure 9. – Wear area of a nickel tip worked in 50 percent sulfuric acid. SEM photograph locations are as shown in the photomicrograph.

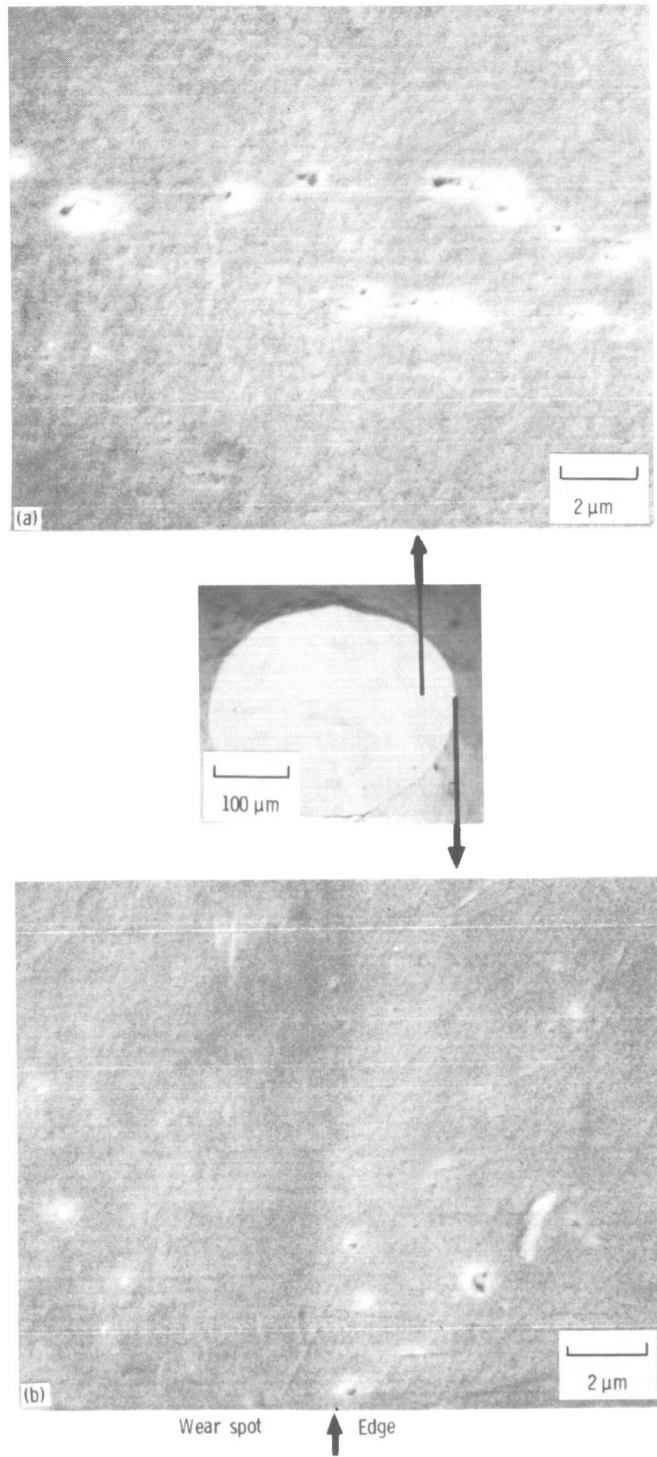

Figure 10. – Wear area of a nickel tip worked in 65 percent sulfuric acid. SEM photograph locations are as shown in the photomicrograph.

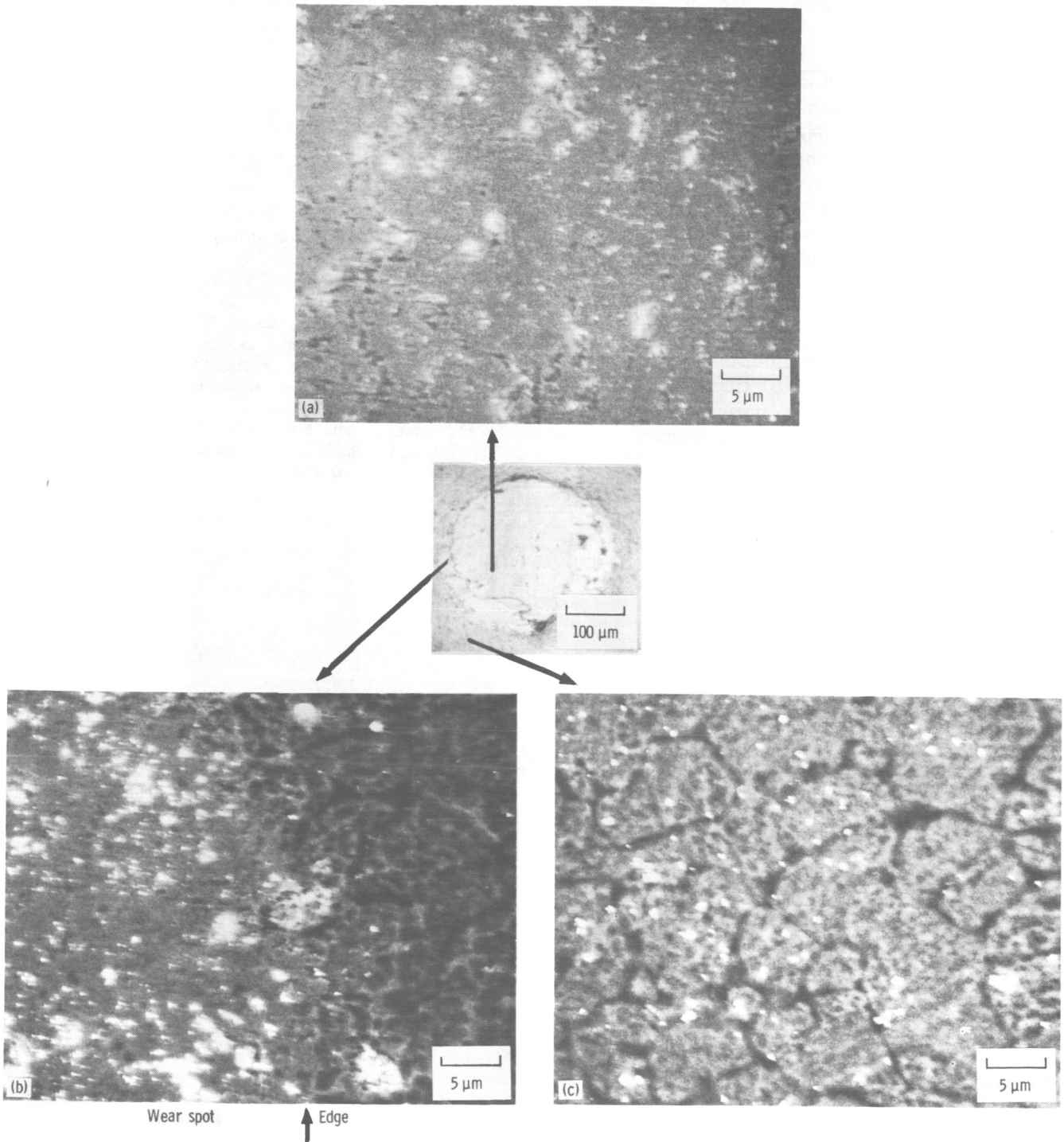

Figure 11. – Wear area and surroundings of a nickel tip worked in 96 percent sulfuric acid. SEM photograph locations are as shown in the photomicrograph.

Conclusions

The variation of loss of nickel sliding on aluminum oxide in aerated sulfuric acid concentrations ranging from very dilute to very concentrated is presented. From the metal behavior in various concentrations are derived the following conclusions:

1. Metal lost by corrosion is a large part of the total metal lost in the wear area over a wide range of acid concentrations (0.5 percent (0.1 N) to 75 percent).

2. The rapid corrosion in the wear area is induced by the wear process. In this process, a protective film normally formed on nickel in sulfuric acid is worn away so that a galvanic cell develops with the wear area as the anode and the surrounding, basically uncorroded area, as a cathode.

3. In the wear area the nickel corrodes as fast as the normal corrosion of iron, a metal notorious for its rapid corrosion in moderate concentrations of sulfuric acid.

4. In the most dilute acid (0.005 percent (10^{-4} N)) no corrosion is observed in the the wear area or its surroundings. The same lack of corrosion was observed in the most concentrated acid (96 percent), but for a different reason. It appears that a film forms fast enough to protect even the wear area.

5. At 0.005 percent (0.001 N) and 0.05 percent (0.01 N) concentrations, little metal was lost by corrosion

even in the wear area, but fluid motion induced by the wear experiments caused local outside areas to corrode.

Lewis Research Center
National Aeronautics and Space Administration
Cleveland, Ohio, January 10, 1984

References

1. Rengstorff, George W. P.; Miyoshi, Kazuhisa; and Buckley, Donald H.: Friction and Wear of Iron in Sulfuric Acid. NASA TP-2289, 1984.
2. Rengstorff, George W. P.; Miyoshi, Kazuhisa; and Buckley, Donald H.: Friction and Wear of Iron in Corrosive Media. NASA TP-1985, 1982.
3. Rengstorff, G. W. P.; Miyoshi, K.; and Buckley, D. H.: Friction and Wear of Iron and Nickel in Sodium Hydroxide Solutions. ASLE Trans., vol. 26, no. 4, Oct. 1983, pp. 509-516.
4. Huntington Alloys, Resistance to Corrosion. The International Nickel Company, Inc., 1965, revised 1970.
5. Fontana, Mars G.; and Greene, Norbert D.: Corrosion Engineering, Second ed. McGraw-Hill, 1978.
6. Weast, Robert C.; and Astle, Melvin J., eds.: Approximate pH Values, CRC Handbook of Chemistry and Physics, 63rd ed., CRC Press, Inc., 1982, p. D-156.

1. Report No. NASA TP-2290		2. Government Accession No.		3. Recipient's Catalog No.	
4. Title and Subtitle Friction and Wear of Nickel in Sulfuric Acid				5. Report Date April 1984	
				6. Performing Organization Code 506-53-12B	
7. Author(s) George W. P. Rengstorff, Kazuhisa Miyoshi, and Donald H. Buckley				8. Performing Organization Report No. E-1817	
				10. Work Unit No.	
9. Performing Organization Name and Address National Aeronautics and Space Administration Lewis Research Center Cleveland, Ohio 44135				11. Contract or Grant No.	
				13. Type of Report and Period Covered Technical Paper	
12. Sponsoring Agency Name and Address National Aeronautics and Space Administration Washington, D.C. 20546				14. Sponsoring Agency Code	
15. Supplementary Notes George W. P. Rengstorff, University of Toledo, Toledo, Ohio (work done under NASA grant NAG3-276); Kazuhisa Miyoshi and Donald H. Buckley, Lewis Research Center.					
16. Abstract Friction and wear experiments were conducted with elemental nickel sliding on aluminum oxide in aerated sulfuric acid in concentrations ranging from very dilute (10^{-4} N, i.e., 5 ppm) to very concentrated (96 percent) acid. Load and reciprocating sliding speeds were kept constant. With the most dilute concentration (10^{-4} N) no observable corrosion occurred in or outside the wear area. This was used as the base condition to determine the high contribution of corrosion to total wear loss at acid concentrations between 0.5 percent (0.1 N) and 75 percent. Corrosion reached a maximum rate of 100 millimeters per year at 30 percent acid. At the same time general corrosion outside the wear area was very low, in agreement with published information. It is clear that friction and wear greatly accelerated corrosion in the wear area. At dilute concentrations of 0.001 and 0.01 N, corrosion in the wear area was low, and general corrosion outside was also low, but local outside regions in the direction of the wear motion experienced some enhanced corrosion, apparently due to fluid motion of the acid.					
17. Key Words (Suggested by Author(s)) Tribology			18. Distribution Statement Unclassified - unlimited STAR Category 26		
19. Security Classif. (of this report) Unclassified		20. Security Classif. (of this page) Unclassified		21. No. of pages 16	22. Price* A02

*For sale by the National Technical Information Service, Springfield, Virginia 22161

NASA-Langley, 1984

National Aeronautics and
Space Administration

Washington, D.C.
20546

Official Business
Penalty for Private Use, \$300

THIRD-CLASS BULK RATE

Postage and Fees Paid
National Aeronautics and
Space Administration
NASA-451



6 2 10, C, 840417 S00161DS
DEPT OF THE AIR FORCE
ARNOLD ENG DEVELOPMENT CENTER (AFSC)
ATTN: LIBRARY/DOCUMENTS
ARNOLD AF STA TN 37389

NASA

POSTMASTER:

If Undeliverable (Section 158
Postal Manual) Do Not Return
