

JPL Publication 83-74



A Survey of Gas-Side Fouling in Industrial Heat-Transfer Equipment

Final Report

W.J. Marnier
J.W. Sutor

(NASA-CR-173469) A SURVEY OF GAS-SIDE
FOULING IN INDUSTRIAL HEAT-TRANSFER
EQUIPMENT Final Report (Jet Propulsion
Lab.) 168 p HC A08/MF A01 CSCL 10B

N84-22003

Unclass
18381

G3/44

November 1983

Prepared for
U S Department of Energy
Pacific Northwest Laboratory
Battelle Memorial Institute
Through an Agreement with
National Aeronautics and Space Administration
by
Jet Propulsion Laboratory
California Institute of Technology
Pasadena, California

JPL Publication 83-74

A Survey of Gas-Side Fouling in Industrial Heat-Transfer Equipment

Final Report

W.J. Marner
J.W. Sutor

November 1983

Prepared for

U.S. Department of Energy
Pacific Northwest Laboratory
Batelle Memorial Institute

Through an Agreement with
National Aeronautics and Space Administration

by

Jet Propulsion Laboratory
California Institute of Technology
Pasadena, California

Prepared for Battelle Memorial Institute, Pacific Northwest Laboratory, the U.S. Department of Energy through an agreement with the National Aeronautics and Space Administration by the Jet Propulsion Laboratory.

This report was prepared as an account of work sponsored by an agency of the United States Government. Neither the United States Government nor any agency thereof, nor any of their employees, makes any warranty, express or implied, or assumes any legal liability or responsibility for the accuracy, completeness, or usefulness of any information, apparatus, product, or process disclosed, or represents that its use would not infringe privately owned rights.

Reference herein to any specific commercial product, process, or service by trade name, trademark, manufacturer, or otherwise, does not necessarily constitute or imply its endorsement, recommendation, or favoring by the United States Government or any agency thereof. The views and opinions of authors expressed herein do not necessarily state or reflect those of the United States Government or any agency thereof.

ABSTRACT

The results of a survey of gas-side fouling in industrial heat-transfer equipment are presented. Information for this study was obtained through personal contacts, visits to selected industries, attendance at several professional meetings and conferences, and publications in the open literature. Gas-side fouling and corrosion problems occur in all of the energy intensive industries including the chemical, petroleum, primary metals, pulp and paper, glass, cement, foodstuffs, and textile industries. Topics of major interest in this study include: (1) heat exchanger design procedures for gas-side fouling service, (2) gas-side fouling factors which are presently available, (3) startup and shutdown procedures used to minimize the effects of gas-side fouling, (4) gas-side fouling prevention, mitigation, and accommodation techniques, (5) economic impact of gas-side fouling on capital costs, maintenance costs, loss of production, and energy losses, and (6) miscellaneous considerations related to gas-side fouling. The present state-of-the-art for industrial gas-side fouling is summarized by a list of recommendations for further work in this area.

ACKNOWLEDGEMENTS

The information presented in this report was obtained through personal contacts, visits to selected industrial organizations, attendance at several technical meetings and conferences, and from a variety of open literature sources. It is indeed a pleasure to acknowledge the contributions of the following persons, along with their respective employers, who collectively helped to make this report possible:

Donald Anson
Battelle Columbus Laboratories
Columbus, Ohio

Eugene Barrington
Shell Oil Company
Houston, Texas

Mohammed S. Y. Bhatti
Portland Cement Association
Skokie, Illinois

Richard W. Bryers
Foster Wheeler Development Corp.
Livingston, New Jersey

James M. Chenoweth
Heat Transfer Research, Inc. (HTRI)
Alhambra, California

H. J. Danne
Energy Exchanger Company
Tulsa, Oklahoma

Charles Dobos
Gas Research Insititute
Chicago, Illinois

Dan Dyer
Kentube Division of Tranter, Inc.
Tulsa, Oklahoma

Vernon L. Eriksen
Deltak Corporation
Minneapolis, Minnesota

John P. Glass
Happy Division
Therma Technology, Inc.
Tulsa, Oklahoma

William J. Greenlee
Sundstrand Aviation Operations
Rockford, Illinois

Max Greeven
AiResearch Manufacturing Company
Torrance, California

Edward E. Grove
John Zink Company
Tulsa, Oklahoma

Charles J. Hammack
Engineers and Fabricators Company
Houston, Texas

S. Paul Henslee
EG & G Idaho, Inc.
Idaho Falls, Idaho

James D. Isdale
National Engineering Laboratory
Glasgow, Scotland

Stephen E. Kerho
KVB, Inc.
Irvine, California

Daniel D. Langren
Technotherm Corporation
Tulsa, Oklahoma

James W. Locke
Diamond Power Specialty Company
Lancaster, Ohio

John Maberry
Smith Engineering Company
Duarte, California

Arthur Meehan
Industrial Fabricating Company
Tulsa, Oklahoma

Hugo C. Meith
Energy Technology, Inc. (ENTEC)
Houston, Texas

W. E. Moore
Monsanto Chemical Intermediates Co.
Alvin, Texas

Walter B. Munn
Amoco Production Company
Houston, Texas

P. F. Murray
Monsanto Chemical Intermediates Co.
Alvin, Texas

John O'Donnell, Jr.
High Performance Tube, Inc. (HPTI)
Union, New Jersey

A. C. Pauls
Monsanto Company
St. Louis, Missouri

Jerrald Radway
EnerChem Incorporated
Cleveland, Ohio

David Reay
AERE Harwell
United Kingdom

Donald N. Reed
Amoco Production Company
Houston, Texas

M. J. Ruston
Corning Process Systems
Corning Glass Works
Big Flats, New York

Joseph A. Schwartz
KVB, Inc.
Irvine, California

Ramesh Shah
Harrison Radiator Division
General Motors Corporation
Lockport, New York

J. George Sotter
KVB, Inc.
Irvine, California

Tom Spencer
Engineers and Fabricators Company
Houston, Texas

Gregory Theoclitus
C E - Air Preheater
Wellsville, New York

Richard E. Thompson
KVB, Inc.
Irvine, California

Honghi N. Tran
University of Toronto
Toronto, Canada

Stewart W. Tresouthick
Portland Cement Association
Skokie, Illinois

Kenneth Unmack
Aerojet Energy Conversion Company
Sacramento, California

David O. Watts
Energy Recovery Inc.
Tulsa, Oklahoma

Ralph L. Webb
The Pennsylvania State University
University Park, Pennsylvania

Chris Weierman
Escoa Fintube Corporation
Pryor, Oklahoma

Thomas A. Wells
The M. W. Kellogg Company
Houston, Texas

Richard A. Wenglarz
Westinghouse R&D Center
Pittsburgh, Pennsylvania

Doug Werner
Barber-Nichols Engineering Company
Arvada, Colorado

George Wieland
Bethlehem Steel Corporation
Bethlehem, Pennsylvania

Howard W. Williams
Aerojet Energy Conversion Company
Sacramento, California

John D. Young
John Zink Company
Tulsa, Oklahoma

E. C. Winegartner
Exxon Research and Engineering Company
Baytown, Texas

This work was performed by the Instrumentation Section, Applied Mechanics Division, Jet Propulsion Laboratory (JPL), California Institute of Technology, Pasadena, California. The project was carried out for the Battelle, Pacific Northwest Laboratory, Richland, Washington, and the U.S. Department of Energy (DOE) under P.O. B-D2119-A-X and through NASA Interagency Agreement NAS-7-918, Task Order RE-152, Amendment 366. The Program Manager for this project was Nancy L. Moore, Advanced Technology Economics, Pacific Northwest Laboratory, Battelle Memorial Institute, Richland, Washington, whose resourcefulness, interest, and support are gratefully acknowledged. Finally, a special note of thanks goes to Dee Darrow who was responsible for typing the manuscript.

CONTENTS

	<u>Page</u>
1. INTRODUCTION	1-1
2. A BRIEF OVERVIEW OF GAS-SIDE FOULING	2-1
2.1 DEFINITION AND CLASSIFICATION OF FOULING	2-1
2.2 CATEGORIZATION OF FUELS	2-3
2.3 CHARACTERIZATION OF COMBUSTION GASES	2-6
2.4 GAS-SIDE FOULING CHARACTERISTICS AND MECHANISMS	2-7
2.5 DESIGN OF HEAT-TRANSFER EQUIPMENT FOR GAS-SIDE FOULING SERVICE	2-8
2.6 OPERATION AND CLEANING OF HEAT-TRANSFER EQUIPMENT IN DIRTY GAS ENVIRONMENTS	2-10
3. HEAT-EXCHANGER DESIGN FOR GAS-SIDE FOULING SERVICE	3-1
3.1 THE ROLE OF THE FOULING FACTOR	3-1
3.2 TYPES OF HEAT-TRANSFER EQUIPMENT	3-2
3.2.1 Recuperators	3-3
3.2.2 Regenerators	3-19
3.2.3 Direct Contact Heat Exchangers	3-21
3.2.4 Fluidized Bed Heat Exchangers	3-26
3.2.5 Heat Pipe Heat Exchangers	3-28
3.3 MATERIALS CONSIDERATIONS	3-30
3.3.1 Low-Temperature Range, $T_{\text{gas}} < 500 \text{ F}$	3-31
3.3.2 Intermediate-Temperature Range, $500 \text{ F} < T_{\text{gas}}$ $< 1500 \text{ F}$	3-39
3.3.3 High-Temperature Range, $T_{\text{gas}} > 1500 \text{ F}$	3-42
3.4 SUMMARY	3-48

	<u>Page</u>
4. EXISTING GAS-SIDE FOULING FACTORS	4-1
4.1 FOULING FACTORS FOR FINNED TUBE BANKS COMPILED BY R.C. WEIERMAN	4-1
4.2 THE JOHN ZINK COMPANY RECOMMENDATIONS	4-1
4.3 TEMA FOULING FACTORS	4-3
4.4 EG&G IDAHO DIESEL EXHAUST FOULING FACTORS	4-4
4.5 DAVID W. TAYLOR R&D CENTER GAS TURBINE EXHAUST FOULING FACTORS	4-6
4.6 AIR-COOLER FOULING FACTOR USED BY AMOCO PRODUCTION COMPANY .	4-6
4.7 ENTEC FIRED HEATER AND WASTE HEAT BOILER FOULING FACTOR . .	4-7
4.8 COMPARISON OF FOULING FACTORS FOR COMBUSTION GAS STREAMS . .	4-7
4.9 SUMMARY	4-9
5. STARTUP AND SHUTDOWN PROCEDURES TO MINIMIZE THE EFFECTS OF GAS-SIDE FOULING	5-1
5.1 USE OF CLEAN FUEL DURING STARTUP CONDITIONS	5-1
5.2 MAINTAIN HEAT-EXCHANGER SURFACES ABOVE DEWPOINT TEMPERATURES	5-3
5.3 USE OF BYPASS TO AVOID LOW VELOCITIES	5-3
5.4 EXPERIENCE WITH AN ORGANIC RANKINE BOTTOMING CYCLE SYSTEM .	5-4
5.5 SHUTDOWN OPERATIONS	5-6
5.6 SUMMARY	5-7
6. GAS-SIDE FOULING PREVENTION, MITIGATION, AND ACCOMMODATION TECHNIQUES	6-1
6.1 FUEL CLEANING TECHNIQUES	6-1
6.2 CONTROL OF COMBUSTION CONDITIONS	6-2
6.3 FUEL AND GAS ADDITIVES	6-4
6.3.1 Oil-Fired Systems	6-4
6.3.2 Coal-Fired Systems	6-9

	<u>Page</u>
6.3.3 Oil-Fired Additives: A Brief Case History	6-10
6.3.4 The Mitigating Effects of Magnesium-Based Additives	6-11
6.4 SURFACE CLEANING TECHNIQUES	6-12
6.4.1 Steam and Air Sootblowers	6-12
6.4.2 Sonic Sootblowers	6-17
6.4.3 Water Washing	6-21
6.4.4 Other Cleaning Techniques	6-23
6.4.5 Cleaning Techniques for Plate-Fin Heat Exchangers .	6-24
6.5 QUENCHING	6-27
6.6 CONTROL OF OPERATING CONDITIONS	6-28
6.7 GAS-CLEANING TECHNIQUES	6-32
6.8 SUMMARY	6-34
7. ECONOMIC IMPACT OF GAS-SIDE FOULING	7-1
7.1 THE DELETERIOUS EFFECTS OF GAS-SIDE FOULING	7-1
7.2 THACKERY'S ANALYSIS OF THE COST OF FOULING IN THE UNITED KINGDOM	7-3
7.3 WEIERMAN'S ANALYSIS OF GAS-SIDE FOULING COSTS ON EQUIPMENT .	7-4
7.4 ESTIMATED COSTS OF STEAM SOOTBLOWING	7-6
7.5 ESTIMATED COSTS OF GAS-SIDE FOULING IN CEMENT PLANTS	7-7
7.6 GAS-SIDE FOULING COSTS IN THE PETROLEUM INDUSTRY	7-8
7.7 TOTAL GAS-SIDE FOULING COSTS IN U.S. INDUSTRIES	7-8
7.8 SUMMARY	7-10
8. ADDITIONAL CONSIDERATIONS RELATING TO GAS-SIDE FOULING	8-1
8.1 CHARACTERIZATION OF COMBUSTION GASES	8-1
8.2 GAS-SIDE FOULING MEASURING DEVICES	8-3

	<u>Page</u>
8.3 GAS-SIDE FOULING AND CORROSION PROBLEMS RELATED TO THE BURNING OF WASTE MATERIALS	8-4
8.4 DISSEMINATION OF GAS-SIDE FOULING INFORMATION	8-5
9. GAS-SIDE FOULING R&D NEEDS	9-1
REFERENCES	R-1
APPENDICES	
A. List of Industrial Organizations Visited	A-1
B. List of Conferences, Meetings, Workshop, and Short Courses Attended	B-1

Figures

	<u>Page</u>
3-1. The Shell-and-Tube Heat Exchanger	3-4
3-2. A Schematic Diagram of a Steam Power Plant	3-5
3-3. A Cylindrical Economizer with Rotary Sootblower	3-6
3-4. A Two-Pass Firetube Boiler	3-9
3-5. External and Internal Bypass in Firetube Boiler for Exit Gas Temperature Control	3-10
3-6. A Gas-to-Air Heat Exchanger Used in the Cement Industry	3-12
3-7. Solid and Segmented Welded Finned Tubes	3-14
3-8. A Comparison of Inline Versus Staggered Layouts	3-15
3-9. Plate-Fin Heat Exchanger Construction	3-17
3-10. The Rotary Regenerator	3-20
3-11. Suspension Preheater Used in the Cement Industry	3-23
3-12. Low-Temperature Direct Contact Heat Exchanger	3-25
3-13. A Schematic Drawing of a Fluidized Bed Heat Recovery System	3-27
3-14. Schematic Drawing of a Heat Pipe Heat Recovery System	3-29
3-15. Acid Dewpoint Temperature of Combustion Gases from Fuel Oil as a Function of Sulfur Content	3-32
4-1. Experimental Diesel Exhaust Fouling Resistances	4-5
5-1. The Cleaning History in a Sundstrand OKBC Preheater	5-5
6-1. Probable Soot Deposition Rates with Combustion System Parameters	6-3
6-2. The Rotary and Long Retractable Sootblower	6-15
6-3. The KV3 Acousticlean Sonic Sootblower	6-18
6-4. The Diamond Power Infrasonic Hz-20 Sonic Sootblower	6-20

Tables

	<u>Page</u>
1-1. Industries Susceptible to Gas-Side Fouling and Corrosion Problems	1-4
2-1. Categorization of Fuels Used to Generate Combustion Gases . .	2-4
2-2. Use of Fuels in Various Industries According to SIC Classification	2-5
3-1. Air Froehlich Glass Tube Recuperator Applications	3-35
3-2. Materials Tested for High-Temperature Heat Recovery in the Aluminum Industry	3-45
4-1. Design Parameters for Extended Surfaces in Fossil Fuel Exhaust Gases	4-2
4-2. Recommended Fouling Factors ($\text{hr-ft}^2\text{-F/Btu}$) and Fin Pitch (fins per foot) for Various Flue Gases	4-3
4-3. TEMA Fouling Factors	4-4
4-4. Fouling Factors for Gas Turbine Exhaust	4-6
4-5. Comparison of Available Gas-Side Fouling Factors	4-8
6-1. Additive Trials Rated as Effective for SO_3 -Related Problems .	6-6
6-2. Additive Trials Rated as Effective for Vanadium and Sodium-Related Problems	6-7
6-3. Additives Effective in Coal-Fired Boilers	6-9
6-4. Sootblower Design and Operation	6-13
6-5. ENTEC Sootblower Specification as a Function of Ash Content .	6-14
7-1. Estimated Annual Costs of Fouling in the United Kingdom . . .	7-4
7-2. Summary of Estimated Annual Costs in U.S. Cement Plants Due to Gas-Side Fouling, Corrosion, and Erosion	7-7
7-3. Estimated Annual Gas-Side Fouling Costs in U.S. Industries .	7-10
9-1. R&D Recommendations for Industrial Gas-Side Fouling	9-2

SECTION 1

INTRODUCTION

Fouling of heat-transfer equipment has long plagued the energy-related industries. Most of the early efforts in this area were directed toward the solution of liquid-side fouling problems. However, owing to increased interest in heat recovery from exhaust gas streams -- stimulated in large part by increasing fuel costs -- considerable attention has recently been focused on gas-side fouling. Interest in this subject is found among workers in private industries, public utilities, various research organizations, national laboratories, professional societies, and local, state, and federal governments. A brief review of some of the major activities related to gas-side fouling which have taken place during the last 10-12 years will help put the magnitude and scope of this problem into proper perspective.

In 1970 Battelle Columbus Laboratories, under the sponsorship of the American Society of Mechanical Engineers (ASME) Research Committee on Corrosion and Deposits from Combustion Gases, published an extensive bibliography on corrosion and deposits from combustion gases (Reference 1-1). The following year saw the publication of the now classic reference on deposits and corrosion in boilers and gas turbines by W. T. Reid (Reference 1-2). In 1971, Taborek, et al. (Reference 1-3) provided a systematic treatment of fouling which has come to be recognized as a major contribution to the subject. In 1974 the ASME Research Committee on Corrosion and Deposits from Combustion Gases, under the leadership of E. C. Winegartner, published a set of guidelines for coal fouling and slagging parameters (Reference 1-4).

In 1978 and 1981, R. W. Bryers of the Foster Wheeler Development Corporation organized international conferences of major importance on ash deposits and corrosion from combustion gases (Reference 1-5,6). Epstein (Reference 1-7) presented an overview of fouling in 1978 at the Sixth International Heat Transfer Conference in Toronto, Canada in which he proposed six basic types of fouling, an approach which has since become widely accepted.

In 1979 Somerscales and Knudsen organized the first International Fouling Conference which was held at Rensselaer Polytechnic Institute in Troy, New York. The conference proceedings published the following year contain several outstanding review articles as well as a number of recommendations for fouling R&D projects (Reference 1-8). In 1980 Battelle Columbus Laboratories completed an extensive review of fireside additives for the Electric Power Research Institute (EPRI) (Reference 1-9). This effort was followed in the same year by a workshop on oil and gas additives held in Boston, Massachusetts, which was attended by 116 representatives from industry, national laboratories, and the electric utilities. (Reference 1-10).

In 1981 the U.S. Department of Energy (DOE) sponsored a Workshop on the Assessment of Gas-Side Fouling in Fossil Fuel Exhaust Environments at Boulder, Colorado (Reference 1-11). The 41 participants at that workshop, consisting primarily of representatives from industry, formulated a list of high priority R&D recommendations for gas-side fouling. The Second International Fouling Conference, held at White Haven, Pennsylvania in November, 1982, was organized by R. W. Bryers (Reference 1-12). It should be pointed out that the Engineering Foundation was instrumental in organizing both the international conferences on ash deposits and corrosion from combustion gases as well as the International Fouling Conference. DOE commissioned surveys of gas-side fouling in the cement and glass industries which were completed in 1982 and 1983, respectively (References 1-13, 14). The most recent overall review of fouling, including some material on gas-side fouling, was presented by Knudsen (Reference 1-15) at the Seventh International Heat Transfer Conference in Munich, West Germany, held in 1982. Battelle, Pacific Northwest Laboratory (PNL) has recently conducted a Fouling and Corrosion Workshop under DOE sponsorship with emphasis on low temperature (less than 500 F) gas-side fouling and corrosion (Reference 1-16). As an outgrowth of the Gas-Side Fouling Workshop, a bibliography on gas-side fouling including a unique classification scheme, was presented by Marner and Webb (Reference 1-17) in 1983. A second edition of the Battelle Columbus Bibliography (Reference 1-1) is in press and will be available later this year (Reference 1-18). Finally, ASME has just offered a short course on fouling including substantial material on gas-side fouling, which was apparently the first such course ever offered in this country, at the National Heat Transfer Conference in Seattle, Washington (Reference 1-19).

It is clear that gas-side fouling is a subject of considerable interest and importance, one which costs the energy-related industries in the United States a considerable sum of money each year. However, in spite of the efforts in this field many problems remain, and fouling must still be regarded at the "major unresolved problem in heat transfer" (Reference 1-3).

The present study is part of an effort to develop background information -- through Battelle, Pacific Northwest Laboratory, the prime contractor for the project -- for the Office of Industrial Programs (OIP), U.S. Department of Energy (DOE), in planning a long-term, generic research and development (R&D) program on the fouling and corrosion of industrial heat exchangers. The purpose of this report is to present the results of a survey of gas-side fouling in industrial heat-transfer equipment. Topics of particular interest include:

- (a) Economic impact of gas-side fouling on plant operation, maintenance, production, etc.
- (b) Gas-side fouling prevention, mitigation, and accommodation techniques used by industry.
- (c) Startup and shutdown procedures used to minimize the effects of gas-side fouling.
- (d) Gas-side fouling data available in the open literature.
- (e) Heat exchanger design procedures presently being used to account for the effects of gas-side fouling.
- (f) Gas-side fouling and corrosion R&D needs as perceived by industry.
- (g) Additional considerations relating to gas-side fouling.

The information described above was obtained through personal contacts, visits to selected industries, and attendance at several professional meetings and conferences, supplemented by information taken from various publications in

(+)

the open literature. The information from the literature is concentrated on recent developments, much of which is an amplification of information provided by the industrial contacts. The names and affiliations of those persons who contributed in some way to the present study are listed in the Acknowledgements section. The industrial organizations which were visited in person are listed in Appendix A, and the meetings and conferences which were attended are listed in Appendix B.

The present survey was concentrated on gas-side fouling problems which occur in the industrial sector. Those industries of particular interest, listed according to the Standard Industrial Classification (SIC) code (Reference 1-20), are given in Table 1-1.

Table 1-1. Industries Susceptible to Gas-Side Fouling and Corrosion Problems

SIC Code	Description
20	Food and Kindred Products
22	Textile Mill Products
26	Paper and Allied Products
28	Chemicals and Allied Products
29	Petroleum Refining and Related Industries
32	Stone, Clay, Glass and Concrete Products
33	Primary Metal Industries
35	Machinery, Except Electrical

Of these industries, the least amount of attention during this survey was focused on Food and Kindred Products and Textile Mill Products, although there is some reference to gas-side fouling problems in both industries. The major gas-side fouling problems in the Paper and Allied Products industry occur

in pulp and paper mills where tremendous amounts of agricultural wastes are burned on a regular basis. A number of interesting gas-side fouling problems occur in the petrochemical industry which falls in the Chemicals and Allied Products and the Petroleum Refining and Related Industries according to the SIC classification. In the Stone, Clay, Glass and Concrete Products both the glass and cement industries use tremendous amounts of energy and both industries have their share of gas-side fouling problems. The Primary Metal Industries are also quite energy intensive with the aluminum, copper, and iron and steel industries having the major gas-side fouling problems. Finally, the Machinery, Except Electrical category includes both gas turbines and Diesel engines which produce exhaust suitable for heat recovery applications and hence are subject to gas-side fouling and corrosion.

Many aspects of gas-side fouling are unique to specific industries while others tend to be generic to some extent, and the discussions in this report reflect this fact. In addition, selected information from non-industrial sources -- including representative marine, utility, and municipal applications -- is relevant to some industrial problems and has therefore been included in this report. Also, selected results from laboratory-scale studies are included in this report where appropriate. Finally, the gas-side fouling and corrosion problems which occur in industrial applications can be classified according to the temperature range in which they occur. The low-temperature range can be considered to be less than 500 F, the intermediate-temperature range from 500 - 1500 F, and the high-temperature range greater than 1500 F. All three temperature ranges are considered in this study, but the greatest attention is focused on the low- and intermediate-temperature ranges.

SECTION 2

A BRIEF OVERVIEW OF GAS-SIDE FOULING

The subject of gas-side fouling is a very broadly based discipline. The problem originates when a fuel is combusted in a prime mover or direct-fired combustion chamber. Depending on the nature of the fuel and the specific combustion process involved, these combustion gases will contain a variety of condensable and non-condensable gaseous components, as well as some liquid or solid particulate matter. As these hot gases are cooled in some type of heat exchanger -- for example, a direct-fired boiler, a waste heat boiler, an economizer, or an air preheater -- some of the impurities in the gas stream are deposited onto the heat transfer surface. In general, these deposits reduce the heat transfer and increase the pressure drop across the heat exchanger.

Gas-side fouling problems occur to some extent in all of the energy intensive industries including the food, textile, pulp and paper, chemical, petroleum, primary metals, cement, and glass industries. In addition, heat recovery systems utilizing exhaust gases from gas turbines and Diesel engines are also susceptible to gas-side fouling. The purpose of this section is to provide the reader with a brief overview of gas-side fouling. Several of the topics mentioned here will be expanded and discussed in greater detail in later sections of the report as appropriate.

2.1 DEFINITION AND CLASSIFICATION OF FOULING

Fouling may be defined as the deposition of an insulating layer of material onto a heat-transfer surface. If the deposition occurs in the presence of a dirty gas stream, the process is known as gas-side fouling. In many cases, although not always, gas-side fouling is accompanied by corrosion (the destruction of a metal or alloy by means of a chemical or electrochemical reaction with its environment) and/or by erosion (the wearing away of a solid surface by the impact of particulate matter in the gas stream).

Epstein (Reference 1-7) has developed the following classification scheme for fouling:

- (a) Precipitation Fouling - the precipitation of dissolved substances onto the heat transfer surface. Where the dissolved substances have inverse rather than normal solubility versus temperature characteristics, the precipitation occurs on superheated rather than subcooled surfaces and the process is often referred to as scaling.
- (b) Particulate Fouling - the accumulation of finely divided solids suspended in the process fluid onto the heat transfer surface. In a minority of instances settling by gravity prevails, and the process may then be referred to as sedimentation fouling.
- (c) Chemical Reaction Fouling - deposits formed at the heat transfer surface by chemical reactions in which the surface material itself is not a reactant.
- (d) Corrosion Fouling - the heat transfer surface itself reacts to produce corrosion products which foul the surface and may promote the attachment of other foulants.
- (e) Biological Fouling - the attachment of macro-organisms (macro-fouling) and/or micro-organisms (micro-biofouling or microbial fouling) to a heat transfer surface, along with the adherent slimes often generated by the latter.
- (f) Solidification Fouling - freezing of a liquid or some of its higher melting constituents onto a subcooled heat transfer surface.

Of these six categories, all but crystallization fouling can occur in gas-side fouling. Particulate fouling is most likely to be associated with gas-side fouling but chemical reaction fouling, corrosion fouling, and solidification can also be important.

2.2 CATEGORIZATION OF FUELS

A wide variety of fuels are important in applications where gas-side fouling is a potential problem. A fuel categorization scheme -- a slight modification of that presented by Marner and Webb (Reference 1-17) -- is given in Table 2-1. A total of 12 different fuel categories were chosen as indicated.

Fuel Categories 1-6 include all the important fossil fuels and are basically self explanatory. Category 7 includes agricultural wastes, and Category 8 includes miscellaneous wastes of the type burned in municipal incinerators and some industrial applications. Category 9 includes process fuels such as sulfur and phosphorous which are used to produce sulfuric and phosphoric acids. Category 10 includes those situations where constituents of some type are added to a fuel or gas in order to simulate combustion products from a specific type of fuel. Category 11 includes aerosols which, although strictly speaking need not be generated by combustion processes, are very important in many studies relating to particulate fouling transport processes. Finally, a miscellaneous category has been established to include those situations which are not adequately covered by any of the preceding 11 categories. Additional details on the fuel categories are given in Table 2-1.

The use of the fuels in Categories 1 through 9 in the various industries of interest are listed in Table 2-2 according to the SIC code. The symbols H, M, and L are used to designate the relative use of the various combustion fuels within a given industry and represent heavy, moderate, and light usage, respectively. A portion of the information required to generate Table 2-2 was taken from Chiogioji (Reference 2-1). The food and textile industries rely heavily on natural gas as their primary fuel. The pulp and paper industry, on the other hand, uses large quantities of agricultural wastes -- such as pulping liquor residue, hog fuel, and bark -- as well as moderate amounts of gaseous and petroleum fuels. The chemical industry also uses large quantities of gaseous and petroleum fuels, especially heavy liquid feedstock and process fuels which are used to produce chemicals such as sulfuric and phosphoric acid. The petroleum industry relies heavily on gaseous fuels, some of which are

Table 2-1. Categorization of Fuels Used
to Generate Combustion Gases

-
1. Gaseous Fuels
Clean gaseous fuels including natural gas, propane, butane, etc.
 2. Light Petroleum Fuels
Distillate oils, gasoline, kerosene, No. 2 Diesel fuel, No. 1-4 fuel oils, No. 5 fuel oil (light), JP-5 fuel, etc.
 3. Heavy Petroleum Fuels
Residual oils, No. 5 fuel oil (heavy), No. 6 fuel oil, etc.
 4. Coal
Lignite, sub-bituminous, bituminous, and anthracite.
 5. Coal-Derived Fuels
Coal-derived gases, coal-derived liquids, coal-water mixtures, coal-oil mixtures, SRC-I/II, etc.
 6. Tar Sands and Shale-Derived Fuels
Fuels obtained from shale and tar sands such as shale oil, etc.
 7. Agricultural Wastes
Sawdust, wood chips, paper pulp, bagasse, rice hulls, nut shells, fruit pits, hog fuel, etc.
 8. Miscellaneous Wastes
Solid wastes including paper, wood, grass, cloth, garbage, plastics, dirt, and metals; refuse; sewage sludge; waste liquids; chemical wastes; waste lube oil; waste solvents; auto tires; shredded PVC, etc.
 9. Process Fuels
Gases produced by process fuels such as phosphorous, sulfur, etc.
 10. Simulated Fuels
Gases produced for laboratory studies by adding various constituents including particulate matter to the fuel, to the combustion products, or to heated gases.
 11. Aerosols
Non-reacting gases, frequently existing at ambient conditions, which contain suspended particulate matter.
 12. Miscellaneous/Non-Fuel Specific
Special cases which do not fall under any of the above categories. Examples include a combination of two or more fuels, cases in which the fuel is not specified or is indeterminant, studies in which several fuels are considered in a general sense, etc./studies in which the fuel plays an unimportant or a very minor role.
-

Table 2-2. Use of Fuels in Various Industries
According to SIC Classification

Usage H = Heavy M = Moderate L = Light	Fuel									
		Gaseous Fuels	Light Petroleum Fuels	Heavy Petroleum Fuels	Coal	Coal-Derived Fuels	Tar Sands and Shale-Derived Fuels	Agricultural Wastes	Miscellaneous Wastes	Process Fuels
Industry [SIC]										
Food and Kindred Products [20]		H	M	L	L			L		
Textile Mill Products [22]		H	M	L	L					
Paper and Allied Products [26]		M	M	L	L			H		
Chemicals and Allied Products [28]		H	M	L	L			L	L	M
Petroleum Refining and Related Industries [29]		H	H	H	L	L			L	
Stone, Clay, Glass and Concrete Products [32]										
Glass		H	H	L						
Cement		M	L	L	H		L		L	
Primary Metal Industries [33]										
Aluminum		H	M	L	L					
Copper		H	M	L	L					
Iron and Steel		M	L	L	H	M				
Machinery, Except Electrical [35]										
Diesel Engines			H	M						
Gas Turbines		H	M	L			L			

internally generated off-gases and petroleum fuels. The glass industry uses primarily gaseous and petroleum fuels while the cement industry has moved increasingly toward the use of coal. The primary metals industry relies primarily on natural gas except for the iron and steel industry which obtains about three-fourths of its energy from coal and coal-derived fuels. Finally, in the machinery group, Diesel engines use both light and heavy fuel oils while gas turbines burn primarily gaseous and light petroleum fuels.

2.3 CHARACTERIZATION OF COMBUSTION GASES

A knowledge of the fuel constituents is a very important part of the characterization of combustion gases. For example, residual oil contains sulfur, sodium, vanadium, and small quantities of ash, all of which can be important in gas-side fouling. In addition to substantial amounts of ash -- which contains Al_2O_3 , SiO_2 , and Fe_2O_3 , plus smaller amounts of several other constituents -- coal contains mineral matter such as sulfur and chlorine which contributes to ash deposits and corrosion in coal-fired systems.

Combustion gases contain a variety of gaseous species, some of which are condensable and some of which are corrosive in nature. Therefore, a knowledge of the various gaseous species as well as the dewpoint temperatures of these constituents is a very important consideration in characterizing combustion gases. For example, excess air is known to be a very important parameter in gas-side fouling. In oil- and coal-fired systems the excess air is kept low to minimize the reaction of SO_2 with oxygen to form SO_3 , which in turn can react with H_2O to form H_2SO_4 . On the other hand, in reciprocating engine exhausts 200 to 300 percent excess air is commonplace.

Depending on the type of fuel, and in some cases on the specific process involved, combustion gases can contain a variety of particulates. In gas turbine and diesel engine exhausts, carbon in the form of soot frequently occurs as particulate matter. In coal-fired systems Al_2O_3 , Fe_2O_3 , and SiO_2 are all important particulates. In addition to a knowledge of the particulate constituents, the particle size distribution and the state of the particulates (solid or liquid) are both very important parameters.

Finally, fuel treatments such as premixing the fuel and oxidizer are known to have a profound effect on the downstream gas-side fouling tendencies. Also, the use of fuel additives is one technique used to mitigate the effects of gas-side fouling by producing softer, more friable deposits than would otherwise be obtained.

2.4 GAS-SIDE FOULING CHARACTERISTICS AND MECHANISMS

The basic phenomena of gas-side fouling involve transport to the surface, attachment to the surface, and (in some cases) removal from the surface. Transport to the surface can occur by particle diffusion, vapor diffusion with condensation at the surface, thermophoresis, electrophoresis, diffusiophoresis, inertial impaction, sedimentation, and chemical reactions. In most practical cases, two or more of these transport mechanisms will occur simultaneously. The question of whether a particle sticks or not when it strikes a surface is not well understood. This phenomenon is generally expressed in terms of a sticking probability, which ranges from a value of zero to unity, but predicting this parameter is more of an art than a science at the present time. Shear stress is a very important parameter in the natural removal process as is the phenomena of turbulent bursts, or miniature tornadoes. Of course, the deposit strength, which in general increases with aging of the deposit, tends to act against the removal forces.

In many cases gas-side fouling deposits are accompanied by corrosion of the heat-transfer surface. This phenomenon occurs especially in the case of coal-fired systems where alkali-metal sulfates occur commonly. In oil-fired systems vanadium, sulfur, and chlorine compounds tend to be corrosive, and in those cases where miscellaneous wastes are burned, corrosive deposits are a major problem.

Process contaminated gas-side fouling occurs in a number of important applications. This terminology is used to describe those situations where either a fuel or a combustion gas is mixed with raw materials or various process streams, thus producing deposits which contain constituents other than

those found in the fuel or its products of combustion. An example of process contaminant fouling is that which occurs in the suspension preheater of a cement plant. In that application the pulverized raw feed comes into direct contact with the hot products of combustion which leave the rotary kiln.

Dewpoint condensation is a very important deposition mechanism in gas-side fouling. At elevated temperatures compounds such as Na_2SO_4 , K_2SO_4 , P_2O_5 , Na_2CO_3 , and NaCl are deposited on heat-transfer surface in a variety of important applications. In low-temperature dewpoint condensation, which takes place at temperatures below 500 F, the principal constituents of interest include H_2SO_4 , HCl , and H_2O . Acid deposits tend to be highly corrosive and also to attract particulate matter from the gas stream because of the wet surface created by the condensate. The problem of low temperature condensation and corrosion is frequently avoided by making certain that the surface temperature always remains above the acid dewpoint temperature of the gas stream.

Materials considerations are very important in several gas-side fouling regimes. In those cases where corrosion is a problem stainless steels, super-alloys, glass, and a variety of coatings have been used with varying degrees of success. There is also considerable interest in the use of ceramic materials to withstand the hostile environments of dirty gases at elevated temperatures, i.e., greater than 1500 F.

Finally, there is considerable interest in the development of gas-side fouling predictive methods. However, the present gas-side fouling state-of-the-art lags far behind that of liquids. Therefore, gas-side fouling predictive methods will not be forthcoming until additional gas-side fouling data are obtained over a broad range of governing parameters.

2.5 DESIGN OF HEAT-TRANSFER EQUIPMENT FOR GAS-SIDE FOULING SERVICE

The heat-transfer equipment used in gas-side fouling service may be divided into the following major categories: (a) recuperators, (b) regenerators, (c) fluidized bed exchangers, (d) direct contact exchangers, and (e) heat pipe exchangers. Each of these types of heat exchangers are discussed briefly.

Recuperators include all conventional heat exchangers in which the two fluids are separated by a solid surface, usually a metal or alloy. Examples of recuperators include: direct-fired boilers, fired heaters, waste heat boilers, economizers, air preheaters, and superheaters. These exchangers usually are tubular, but other geometries such as plate fin compact heat exchangers also fall in this category. In the case of tubular exchangers the units are called firetube boilers if the hot gases flow inside the tubes and watertube boilers if the gases flow across the tubebanks.

Regenerators are transient type heat exchangers and consist basically of two types: (a) a rotating wheel with a core matrix in which the hot and cold gases flow on opposite sides of the wheel in a counterflow manner, and (b) a stationary matrix type heat exchanger in which hot and cold gases are alternately routed through the same unit.

As the name implies, a fluidized bed heat exchanger employs a fluidized bed on the hot side of the exchanger which heats either a gas or liquid flowing on the tubeside. The bed material, which is sometimes sand, scours the outside of the tubes and thus tends to mitigate the effects of gas-side fouling. It should be pointed out that finned, rather than plain, tubes are frequently used in fluidized bed heat exchangers.

Direct contact heat exchangers allow the two heat transfer media to come directly together, i.e., in the absence of a solid surface separating the two media. An example of a direct contact exchanger used in industry is that of the suspension preheater employed in the cement industry to preheat pulverized raw feed prior to entering the rotary kiln for calcining.

Heat pipes are being used in selected industrial heat recovery applications. Since the heat pipe is essentially an isothermal tube, the exchanger consists of a bundle of heat pipes, each individually sealed, separated by a partition in the middle of the bundle, perpendicular to the bundle. The hot gases flow on one side of the partition and the cold gases are heated by flowing over the hot tube end, at the opposite end of the unit.

The classical method of designing for gas-side fouling is to oversurface the heat exchanger by using the concept of the fouling factor. However, very limited fouling factors are available for this purpose, and values based on experience are used. In addition, in those cases where heavy gas-side fouling occurs, provisions for regular cleaning of the heat exchanger must be made.

Another option available to the designer in the case of tubular exchangers is whether plain or finned tubes are to be used. In the latter case there are several important parameters relating to gas-side fouling potential including: fin height, fin spacing, fin thickness, and fin material. Layout geometry is also an important parameter. In heat exchangers where soot blowers are used the choice is usually to opt for inline layouts for easier cleaning.

Additional design options, including the choice of materials, are available in gas-side fouling service, and several of these will be discussed in Section 3.

2.6 OPERATION AND CLEANING OF HEAT-TRANSFER EQUIPMENT IN DIRTY GAS ENVIRONMENTS

As mentioned in the previous section, cleaning techniques are a very important consideration in applications where gas-side fouling is a problem. In those cases where heavy deposits occur, the cleaning must generally be done online while the unit is in service. The most widely used cleaning technique is that of sootblowers, using either dry steam or air as the blowing medium. In recent years the use of both low frequency and high frequency sonic sootblowers, or sonic horns, has attracted considerable attention. Water washing is also a very important cleaning technique. Other cleaning methods include: chemical, mechanical, and thermal cleaning. It is very important to match the cleaning technique with the type of deposit in order to optimize the cleaning process and minimize the cleaning costs.

Gas additives have been widely used as a method to mitigate the effects of gas-side fouling. Undoubtedly, the most widely used and most successful

additive, for both oil and coal-fired systems, has been MgO. The particle size distribution, which relates to the surface area of the additive, is an important parameter in this area.

In many cases the best source of information relating to gas-side fouling is obtained from general operating experience in the field. Included here are gas-side fouling problems related to startup, off-design, and shutdown conditions. Many case histories are documented in the literature, with direct-fired coal boilers receiving the greatest attention. However, in recent years a number of heat recovery systems have been installed in a variety of exhaust gas streams and some of this operating experience has also been documented in the literature.

A final consideration in the operation of industrial heat-transfer equipment in dirty-gas environments is the economic impact of gas-side fouling. The deleterious effects of gas-side fouling are well known. However, the problem of obtaining quantitative estimates of the contributing factors is an extremely difficult one; consequently, relatively little is known about the costs of gas-side fouling in U.S. industries.

SECTION 3

HEAT-EXCHANGER DESIGN FOR GAS-SIDE FOULING SERVICE

The designer has a number of tools available to handle potential gas-side fouling problems. Of course, design and operation go hand-in-hand, so a significant amount of relevant gas-side fouling experience -- especially as it relates to design considerations -- is included in this section. Three major topics are considered here: (a) the role of the fouling factor, (b) the various types of heat transfer equipment, and (c) materials considerations. Figures showing representative industrial heat exchangers are included to illustrate the physical aspects of the units in which the gas-side fouling actually takes place. The section on materials is broken down into the three temperature ranges discussed in Section 1.

3.1 THE ROLE OF THE FOULING FACTOR

The classical method for dealing with fouling is through the use of the fouling factor, or fouling resistance, R_f . Consider a heat exchanger in which two fluids are separated by a solid surface. The heat transfer between the two fluids may be expressed as

$$Q = F U_o A_o \text{ LMTD} \quad (3-1)$$

where Q is the heat duty, F is the LMTD correction factor, U_o is the overall heat transfer coefficient, A_o is the total outside surface area, and LMTD is the logarithmic mean temperature difference between the two fluids.

The overall heat transfer coefficient, U_o , is given by

$$1/U_o A_o = 1/h_i A_i + t_w/k_w A_w + 1/h_o A_o + R_{fi}/A_i + R_{fo}/A_o \quad (3-2)$$

where h_i and h_o are the inside and outside convective heat transfer coefficients, A_i is the inside surface area, t_w is the wall thickness, k_w

is the wall thermal conductivity, A_w is the average wall surface area, and R_{fi} and R_{fo} are the inside and outside fouling resistances, respectively. According to Eq. 3-2, the fouling resistances tend to reduce U_o and hence to reduce Q for the exchanger. In order to compensate for this anticipated degradation of thermal performance, additional surface area is specified for the exchanger. The amount of additional area which is specified will, of course, depend on the value of the fouling factor used as well as the magnitude of the other resistances in Eq. 3-2.

At initial startup conditions, when the unit is clean, operation of the unit at the design conditions will produce gas temperatures which are somewhat lower than the design values. If the gas velocity is reduced in an attempt to compensate for this effect, the shear stresses in the gas will also be reduced. Consequently, the gas-side fouling removal forces are reduced, thus actually promoting the possibility of gas-side fouling.

Clearly, fouling factors are transient in nature, and also involve very complicated fouling mechanisms. Starting from a clean surface, fouling increases until, depending on the specific mechanisms involved, in some cases an asymptotic fouling condition is achieved at which time the magnitude of the deposition is equal to that of removal. Constant fouling factors are generally used for design purposes, and this subject will be given further consideration in Section 4.

3.2 TYPES OF HEAT-TRANSFER EQUIPMENT

Broadly speaking, heat-transfer equipment may be grouped as either direct fired units, such as boilers and fired heaters, or as waste heat recovery units. Waste heat recovery equipment may be classified into the following two broad categories (Reference 3-1):

- o Those which are essential from process control considerations, such as a firetube boiler to produce sulfuric or phosphoric acid in a chemical plant.

- o Those which are essential from economic considerations, such as an air preheater in a boiler or a waste heat boiler in gas turbine exhaust.

For purposes of discussion, in this section the different types of heat exchangers in which gas-side fouling can be a problem are grouped as follows:

- (a) Recuperators
- (b) Regenerators
- (c) Direct Contact Exchangers
- (d) Fluidized Bed Exchangers
- (e) Heat Pipe Exchangers.

These exchangers, including some relevant gas-side fouling experience, will be presented along with illustrations as appropriate.

3.2.1 Recuperators

Recuperators are conventional two-fluid heat exchangers in which the fluids are separated by a solid material which is usually some kind of metal or alloy, although materials such as glass and plastics are also used to a limited extent. Many different types of recuperators are manufactured. They are generally designed for steady state operation and serve many different functions in the industrial sector.

Shell-and-Tube Exchangers

Probably the best example of a recuperator is the shell-and-tube heat exchanger such as that shown in Figure 3-1 (Reference 3-2). The shell-and-tube units come in all sizes and shapes and are used in a broad range of applications. Representative examples include: (a) a vertical steam generator utilizing fluid catalytic cracker off-gases in the petroleum industry, (b) a transfer line exchanger used to recover heat in the thermal cracking for olefins production in ethylene plants in the chemical industry, and (c) a gas-to-air heat recovery system utilizing combustion products from a sewage sludge incinerator. Of course, many firetube boilers, which are discussed later in this section, are also special cases of the shell-and-tube heat exchanger.

ORIGINAL DRAWING
OF POOR QUALITY

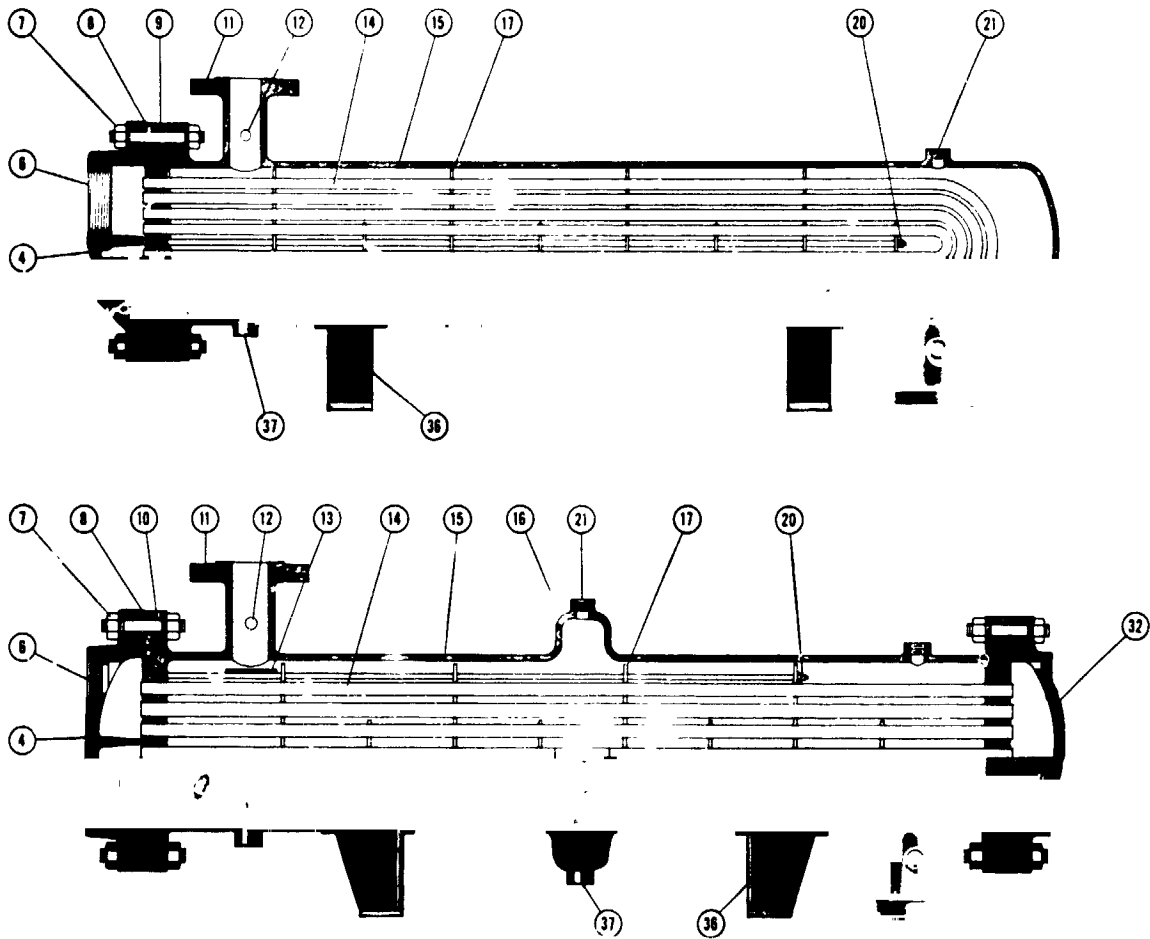

component nomenclature

- | | | | |
|------------------------|------------------------|---------------------------------|---------------------|
| 1—Channel Cover | 11—Shell Nozzle | 21—Vent Connection | 30—Key Ring Flange |
| 2—Channel | 12—Test Connection | 22—Split Backing Flange | 31—Split Key Ring |
| 3—Channel Nozzle | 13—Impingement Baffle | 23—Floating Tubesheet | 32—Reversing Bonnet |
| 4—Bonnet | 14—Tube | 24—Floating Head | 33—Floating Head |
| 5—Bonnet Nozzle | 15—Shell | Reversing Bonnet | Cover Plate |
| 6—Bonnet Connection | 16—Expansion Joint | 25—Lantern-Ring | 34—Shell Cover |
| 7—Bolting | 17—Transverse Baffle | 26—Packing | 35—Lifting Ring |
| 8—Gasket | 18—Support Plate | 27—Stuffing Box | 36—Support Cradle |
| 9—Stationary Tubesheet | 19—Longitudinal Baffle | 28—Gland | 37—Drain Connection |
| 10—Fixed Tubesheet | 20—Tie Rod and Spacer | 29—Floating Tubesheet and Skirt | |

Figure 3-1. The Shell-and-Tube Heat Exchanger (Reference 3-2)

Watertube Boilers

The watertube boiler, usually just called a boiler, is also one of the most common types of recuperators. An industrial boiler consists of the boiler surface and is usually accompanied by a superheater, an economizer which preheats the boiler feedwater, and an air preheater which uses exhaust gases to preheat combustion air as shown schematically in Figure 3-2 (Reference 3-3). An example of an economizer, designed for use in a stack, is shown in Figure 3-3 (Reference 3-4). Note the sootblower at the bottom of Figure 3-3 which is indicated as a rotary element. A discussion of finned tubes shown in Figure 3-3 will be taken up later in this section. Fluids other than water may also be used on the tubeside of boilers. For example, organic liquids such as

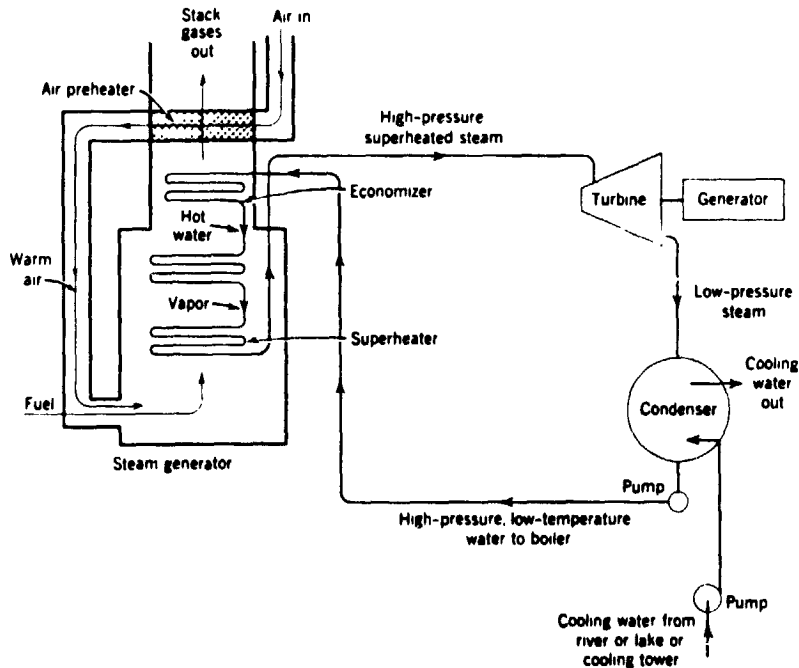

Figure 3-2. A Schematic Diagram of a Steam Power Plant (Reference 3-3)

ORIGINAL DRAWING
OF POOR QUALITY

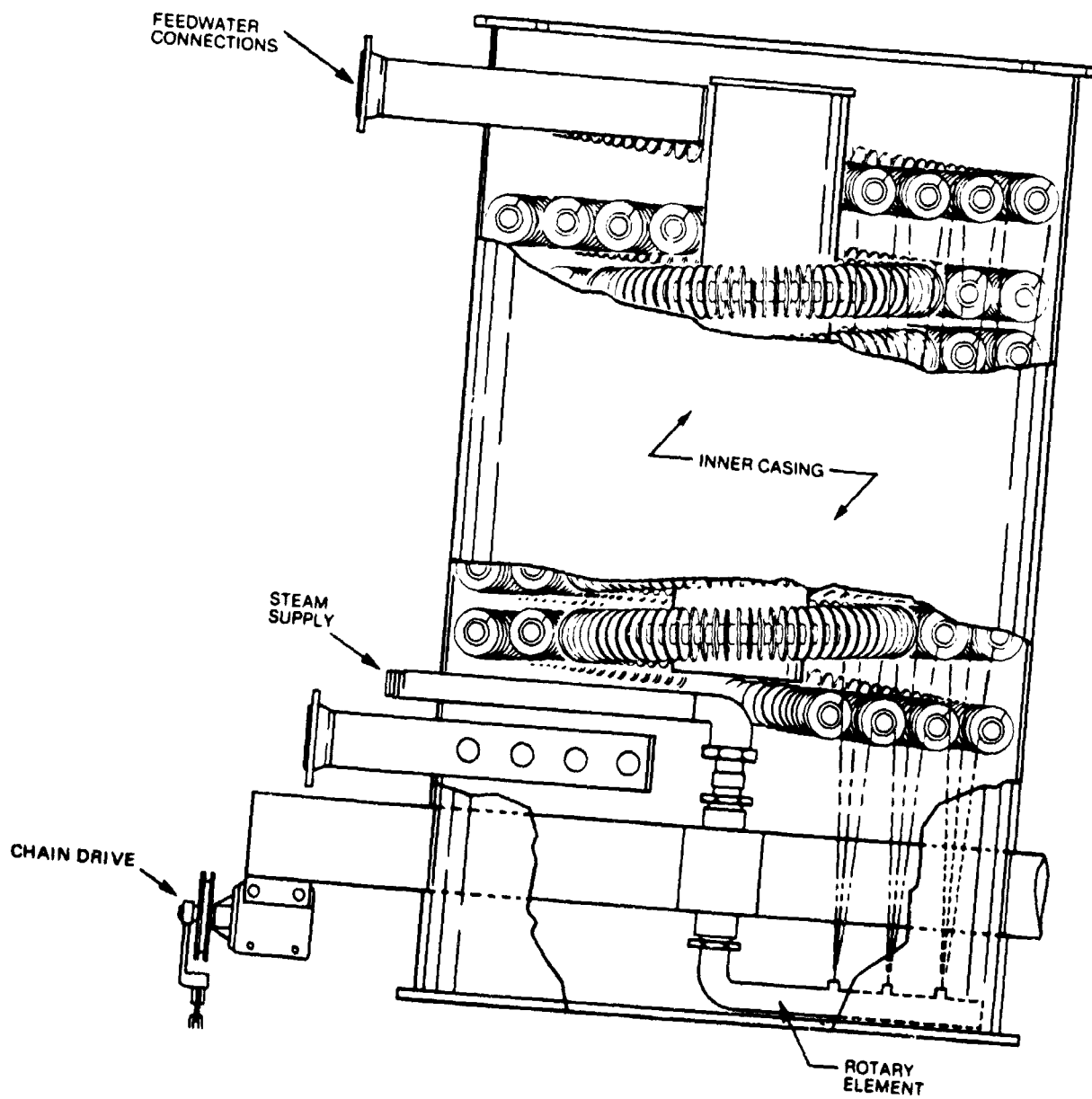

Figure 3-3. A Cylindrical Economizer with Rotary Sootblower
(Reference 3-4)

toluene are commonly used as the working fluid in intermediate temperature Organic Rankine Bottoming Cycles (ORBC) to recover heat from gas turbine and Diesel engine exhausts. Other examples of industrial boilers include enhanced oil recovery (EOR) steamers in the petroleum industry, waste incineration boilers in the chemical industry, and recovery boilers in the pulp and paper industry. Most boilers are equipped with steam sootblowers for online cleaning of the outside surfaces.

Kraft pulp mills make widespread use of boilers using black liquor (spent liquor from the cooking process) and hog fuel (bark, wood chips, and related wastes) as the primary fuels. The spent black liquor is concentrated and used as a fuel in large recovery boilers which are usually equipped with two superheaters. In the lower superheater the deposits are formed primarily by carry over, or inertial impaction, of particulate matter in the combusted gases and consist primarily of Na_2SO_4 and Na_2CO_3 with smaller amounts of NaCl , NaOH , potassium salts, and reduced sulfur compounds. In the upper superheater and on the boiler surface the deposits are formed primarily by the vapor condensation of Na_2SO_4 , NaCl , and a small amount of Na_2CO_3 (Reference 3-5).

A colloquim on gas-side fouling problems in kraft pulp mills was held at the University of Toronto in Ontario, Canada on October 28, 1982 (Reference 3-6). Forty-two representatives, primarily from industrial organizations, met to discuss unit plugging experience, research and development related to deposit formation and characteristics, methods of preventing and controlling deposit accumulation, and the relationship between the deposits and the boiler design and operation. Discussions at the workshop confirmed that the physical characteristics of the deposits are strongly dependent on the flue gas temperature. In the lower superheater, which is exposed to high gas temperatures, the deposits are fused, hard, dense, bonded to the tubes, and difficult to remove using sootblowers. In the upper superheater and on the boiler surface (gas temperatures 900 - 1200 F), the deposits are generally white and may be hard and dense or porous and friable, depending on the temperature. Further back in the unit the deposits are usually white, powdery, and easily removed by sootblowers.

A number of design procedures have been employed in an attempt to deal with these problems: (a) the superheater side spacing has been increased from 10 to 12 in. to reduce plugging, (b) the center spacing in the first four rows of the boiler has been doubled from 4.5 to 9.0 in., (c) considerable attention has been devoted to ensure good alignment of the tubes, (d) careful control of the velocity: always less than 25 ft/sec in the vicinity of the boiler surface and less than 15 ft/sec in the superheat regions, (e) control of the flue gas temperature: maximum of 1700 F entering the superheater region and 1100 - 1300 F entering the boiler bank, and (f) proper primary, secondary, and tertiary air distribution.

Firetube Boilers

In contrast to the watertube boiler discussed above, the hot gases flow inside the tubes in a firetube boiler. An example of a firetube boiler (Reference 3-7) is shown in Figure 3-4. Although not shown, turbulators are frequently placed inside the tubes to enhance the gas-side transfer coefficients which are much lower than those for boiling water (or other liquid) on the shellside. Representative applications using firetube boilers include: (a) waste heat recovery in sulfuric acid plants in the chemical industry, (b) removal of sulfur compounds from sulfur plant tail gas in the chemical industry using waste heat recovery, and (c) process gas cooling from steam/methane reforming furnaces in the petroleum industry.

Firetube boilers are used in some dirty-gas applications to facilitate off-line mechanical cleaning of the inside of the tubes. Walnut shells, or similar abrasive-type materials, are frequently used for online scouring of firetube boilers. In combustion gas streams which contain large quantities of abrasive type particulates, firetube boilers are frequently used because gases of this type would cause severe erosion in flow over exterior surfaces. In such cases ferrules or sleeves are usually placed in the tube inlet to combat the erosive tendencies of the gases as they leave the header and enter the individual tubes.

In some processes, such as the production of sulfuric acid, control of the outlet gas temperature is absolutely essential. This type of control system is effected by means of a bypass which, for a firetube boiler, may be either internal or external as indicated in Figure 3-5 (Reference 3-1). In the contact method of producing H_2SO_4 , raw sulfur is burned with air in a combustion chamber producing SO_2 , O_2 , and N_2 . The gases are at a temperature of about 1900 F and a pressure of 50 in. H_2O and pass through a waste heat boiler where they are cooled to about 800 F, generating steam in the process. The gases then pass through a converter where SO_2 is oxidized to SO_3 in the presence of catalysts. This process may occur in stages. After the last stage of conversion most of the SO_2 gets converted to SO_3 . The SO_3 gases, which are around 900 F ($SO_2 \rightarrow SO_3$ is an exothermic reaction heating the gases by

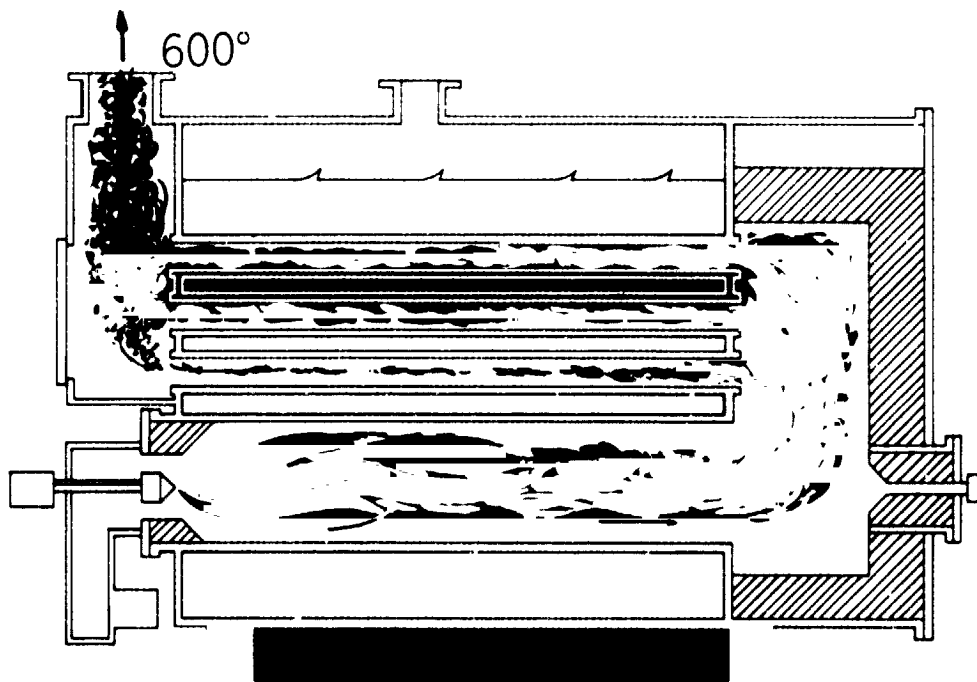

Figure 3-4. A Two-Pass Firetube Boiler (Reference 3-7)

ORIGINAL DRAWING
OF POOR QUALITY

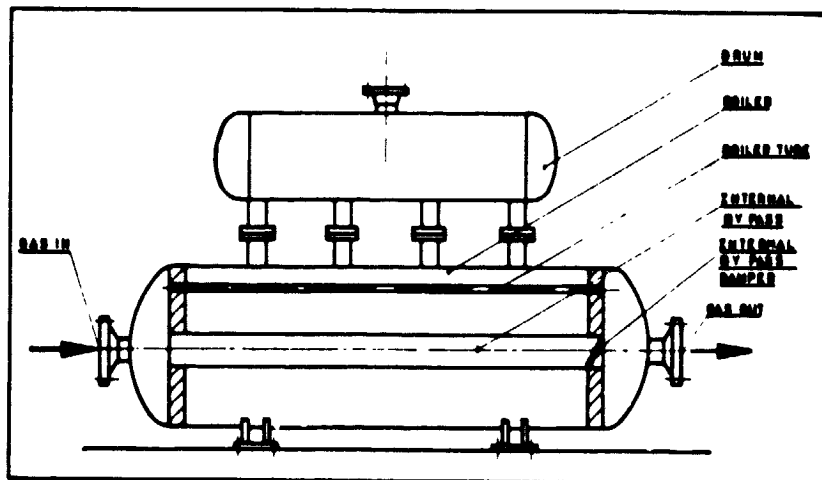
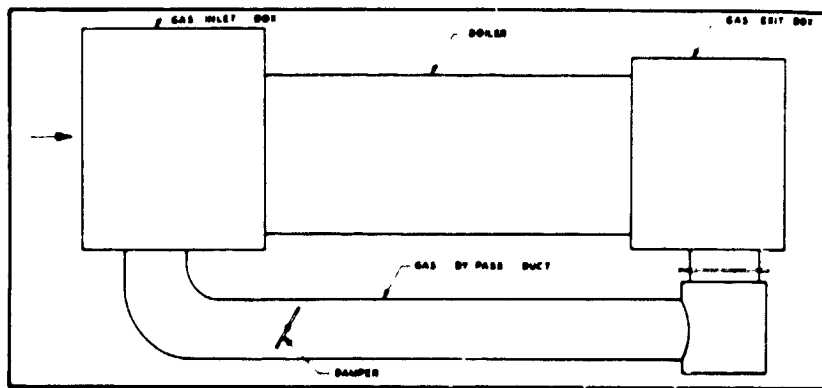

Figure 3-5. External and Internal Bypass in Firetube Boiler for Exit Gas Temperature Control (Reference 3-1)

50 - 100 F) are cooled in an economizer before being sent to an absorption tower where they are absorbed in diluted sulfuric acid to form concentrated H_2SO_4 . In this process, control of the exit gas temperature is critical. The idea behind the bypass is to adjust flow through the boiler so that at lower loads, when the gas temperature falls, the desired exit temperature is still achieved by mixing hot gas with the cool gas through the boiler.

Gas-to-Air Exchangers

A gas-to-air recuperator is shown in Figure 3-6 (Reference 3-8). This particular unit is used to cool hot exhaust gases from a suspension preheater in the cement industry. Hot gases enter the top of the unit at 700 F and flow down the inside of the tubes and on to the baghouse. The air in this particular unit is designed to make four passes over the outside of the tube bundle before exiting at 400 F. This type of exchanger is also used in the cement industry to cool exhaust gases from clinker coolers and preheater bypass streams. These units are very large with tubes typically 20 to 40 ft in length.

In these crossflow heat exchangers the tubes are typically 3 in. in diameter and are arranged on an inline layout with the longitudinal pitch less than the transverse pitch. The hot, dirty gases are placed on the tubeside to facilitate off-line mechanical cleaning, if necessary. A replaceable sleeve, five diameters in length, is placed in the tube inlet to handle inlet erosion problems. These inserts are particularly important in the clinker cooler applications where the exhaust gases are highly abrasive.

In one unit which was installed in a preheater application at the Monarch Cement Company in Humboldt, Kansas, an interesting problem occurred (Reference 3-9). Operation of the gas-to-air exchanger at this installation resulted in a 1/4-in. buildup of particulate matter from the gas stream on the inside of the tubes in a very short period of time. After an extensive analysis, it was finally concluded that static charges picked up in the suspension preheater by the particles were primarily responsible for the

ORIGINAL PAGE IS
OF POOR QUALITY

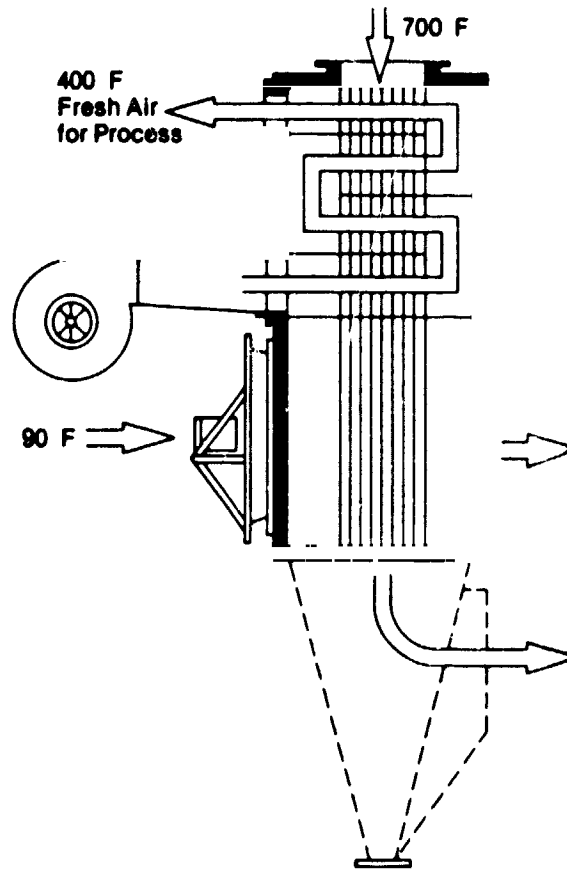

Figure 3-6. A Gas-to-Air Heat Exchanger Used in the Cement Industry (Reference 3-8)

gas-side fouling of the exchanger. The basic operation of the suspension preheater is discussed in more detail in Section 3.2.3 on direct contact heat exchangers.

Finned-Tube Exchangers

Gas-side heat transfer coefficients are relatively low in comparison to those for liquids and phase change applications. Thus, extended surfaces are widely used to enhance tubular exchangers for gas-side service by increasing the surface area of the tubes. The fins are helically wrapped and welded and

are typically solid or segmented as shown in Figure 3-7 (Reference 3-10). Round and elliptical studs are also used but not as extensively as fins. It should be pointed out that augmentation of gas-to-gas heat exchangers requires enhancement on both sides of the unit in order to be effective. However, in gas-to-liquid exchangers enhancement devices are required only on the gas side.

There is considerable controversy over the relative cleanability of the segmented versus solid fins as the following two statements from the literature indicate:

Segmented and plain fins are most frequently used as extended surface. We prefer the segmented ones not only for its slightly lower weight and slightly higher heat absorption (in most practical cases) with the same fin-configuration, but also because it is easier to keep clean. This is because the sharp edges of the segments cut larger particles in pieces and also because the steam jets emerging from the sootblower orifices can penetrate between the cuts to the root of the fins while in the case of the plain fins the shaded area behind the plain fins are hard to reach. There is proof that with narrower fin segments cleaning is still easier.

Csathy (Reference 3-11)

Both solid (or smooth) and serrated (or segmented) continuously welded finned tubes are available. Serrated-type finned tubes should be used only in a clean gas stream. Although the serrated fin does offer somewhat better heat transfer than the solid fin, soot can quickly accumulate in its serrations, with cleaning becoming a real problem. As a result, only solid-type fins are recommended in dirty gas streams where oil, coal, wood, or other high-fouling fuels are burned.

Smittle (Reference 3-12)

Interestingly, DeAnda (Reference 3-13) found that in the case of No. 6 Diesel fuel exhausts, both the segmented and solid finned tubes fouled at about the

ORIGIN
OF POOR QUALITY

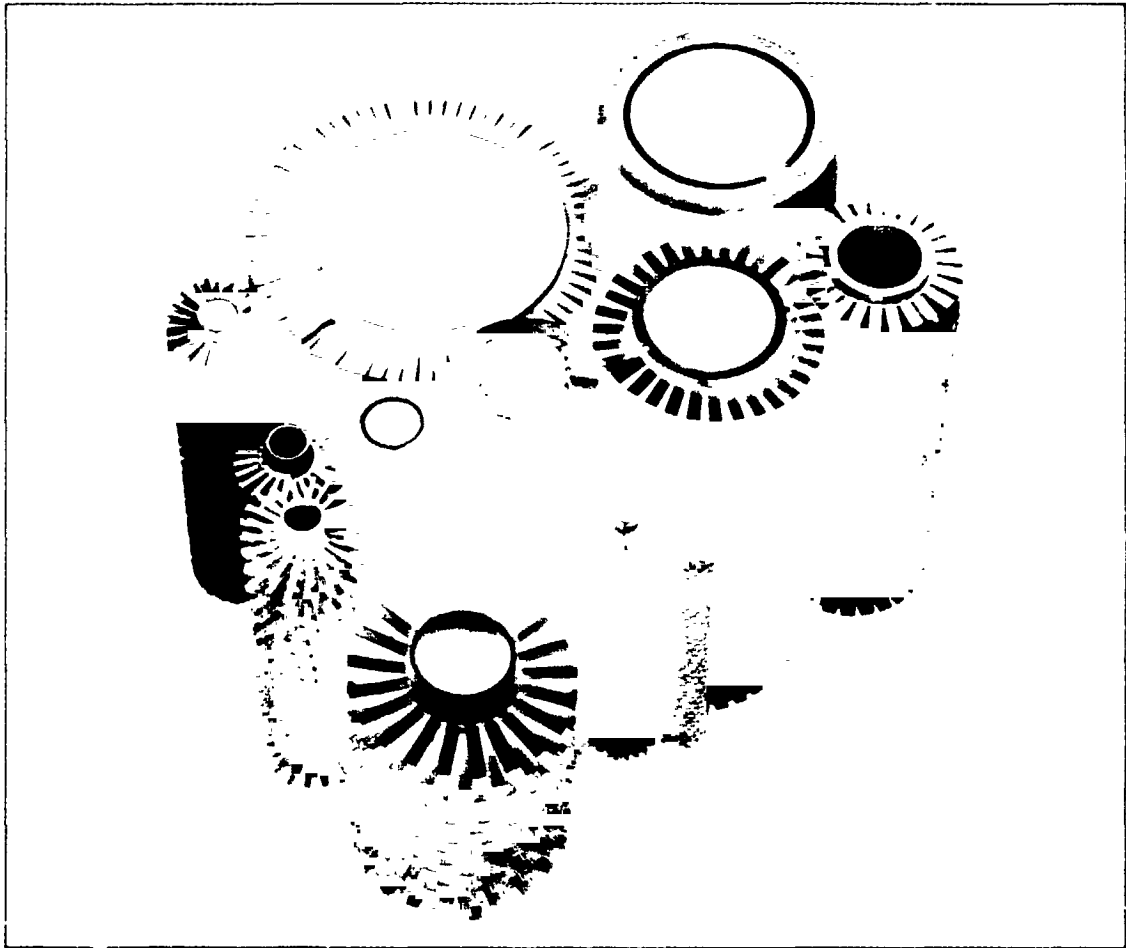

Figure 3-7. Solid and Segmented Welded Finned Tubes
(Reference 3-10)

same rate. Clearly, the topics of gas-side fouling and cleaning of plain versus segmented finned tubes are in need of further attention.

In general, the type of fin, the fin thickness, the fin height, and the number of fins per unit length are all important parameters. As a general rule, the dirtier the fuel, the more widely spaced the fins should be. For example, in coal-fired systems no more than three fins per inch should be used, while for natural gas six fins per inch is customary.

Finned tubebanks are used in crossflow heat exchangers with the dirty gases flowing over the outside of the tubes. In addition to the tube geometry, the layout geometry is also an important parameter. The layout can be either staggered or inline as shown in Figure 3-8.

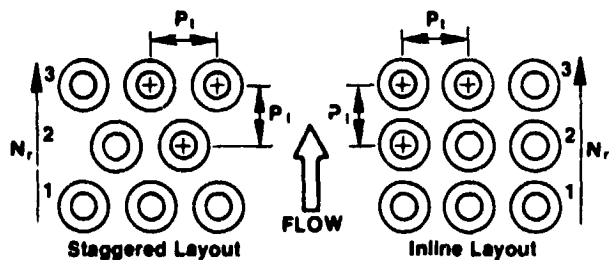

Figure 3-8. A Comparison of Inline Versus Staggered Layouts
(Reference 3-10)

Profos and Sharon (Reference 3-14) indicate that "experience has shown that inline tubebanks are easier to clean by mechanical means, while sootblowers are about equally effective for the two arrangements." In spite of this research-based finding, most engineers specify inline layouts when the installation of sootblowers is required. In either case it is customary to use a wider pitch when designing for dirtier fuels. It should also be pointed out that there is a severe penalty on the heat-transfer performance of inline

versus staggered layouts when finned tubes are used. In a relatively recent study by Weierman, Taborek, and Marner (Reference 3-15), who tested several segmented-finned-tube bundles, it was found that four staggered rows gave about the same heat transfer performance as seven inline rows. These experimental tests were carried out under clean, unfouled conditions.

Plate-Fin Exchangers

The next type of recuperator to be considered here is the plate-fin exchanger. This type of compact surface has long been used in the aerospace and automotive industries. Recently, there has been a tremendous interest in this type of exchanger for heat recovery applications. Both Harrison Radiator Division (Reference 3-16) and AiResearch Manufacturing Company (Reference 3-17, 3-18) have developed high-performance plate-fin recuperators for industrial applications. However, Harrison has recently dropped its product line because of the current economic situation (Reference 3-19).

AiResearch has developed a family of high-performance metallic recuperators for use in industrial gas streams up to 1500 F. They utilize a counterflow heat transfer arrangement with crossflow end sections for fluid manifolding and a compact plate-fin brazed structure. A typical plate-fin matrix construction is shown in Figure 3-9 (Reference 3-18). It consists of a series of parallel plates which form the fluid flow passages. Corrugated sheet stock (fins) is placed between the plates to enhance the heat transfer performance. Ferritic stainless steel is used for both the plates and the fins. An offset rectangular fin pattern is used for applications where the gases are relatively clean. For dirty combustion gas streams, where gas-side fouling is a major concern, a plain fin which provides a relatively open passage fin pattern is available.

In 1978 the plate-fin recuperator was demonstrated in flue gases from a reverberatory aluminum remelt furnace at the AiResearch Casting Company. The unit was installed in 1978 and continued for three years with an average fuel savings of 31 percent. In addition to the aluminum furnace application, the Garrett plate-fin recuperator has also been installed in a steel plant

ORIGINAL PRINT IS
OF POOR QUALITY

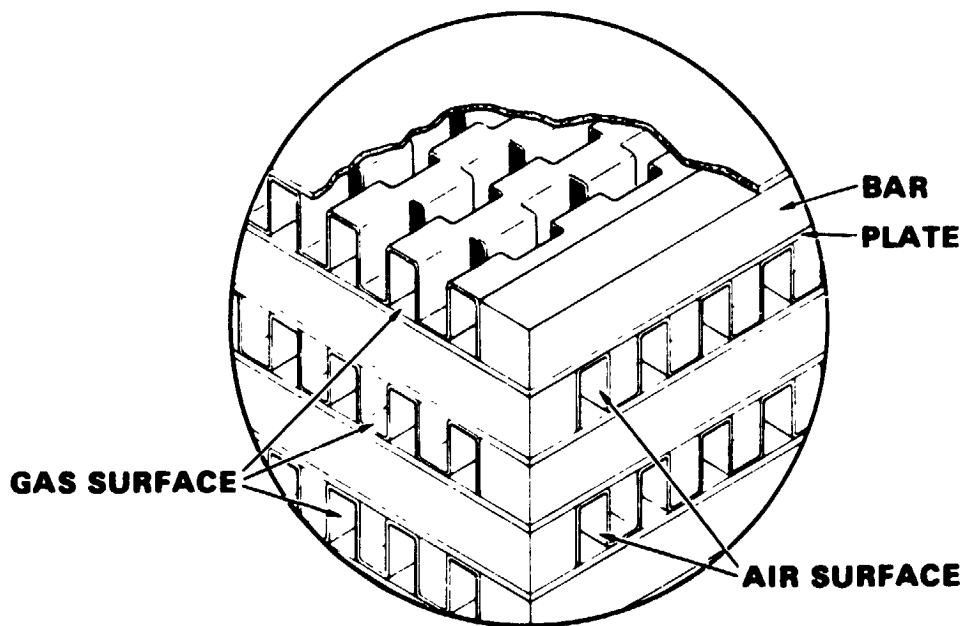

Figure 3-9. Plate-Fin Heat Exchanger Construction
(Reference 3-18)

annealing furnace, a steel casting car bottom furnace, and in clay and grain drying operations. Additional information relating to operating and cleaning experience with the Garrett plate-fin heat recovery system may be found in Sections 5 and 6.

Exchangers for Fluid Catalytic Cracker Units (FCCU)

In the petroleum industry, catalytic cracking is used to break heavy fractions, primarily gas oils, into lower molecular weight fractions. Fluid bed catalytic processes make use of a finely powdered catalyst in a fluid bed to carry out the thermal decomposition process (Reference 2-1). The catalyst is periodically regenerated by burning off deposited carbon at a temperature of 1000 - 1400 F at pressures up to 30 psig. Thus, the flue gases leaving the regenerator -- which typically contain large quantities of catalyst fines and carbon monoxide, CO -- are hot, pressurized, and combustible and are suitable for heat recovery. Because of the somewhat unique characteristics of this process, the gas-side fouling experience with FCCU is considered separately in this section.

In the Mobil Oil Refinery in Torrance, California, natural gas is used almost exclusively as the combustion fuel. The only gas-side fouling problem at this plant occurs in conjunction with a FCCU (Reference 3-20). The effluent gases from the regenerator contain substantial amounts of CO from the carbon oxidation in the regenerative process. These gases are burned in a CO boiler and the heat recovered is used to generate steam in a waste heat boiler. The first few rows of tubes in this exchanger are smooth tubes in order to shield the remaining finned tubes from the direct impact of the catalyst fines, some of which deposit at the root of the finned tubes. The unit exit temperature is maintained above 300 F so there are no acid and water dewpoint problems. However, the sootblowers, which are operated once per shift, are not cleaning the finned tubes satisfactorily.

Krowech (Reference 3-21) has presented an interesting case study which involved a FCCU in another petroleum refinery application. The gases were available for heat recovery at 1325 F and 7 psig and contained 0.23 grains/SCF of catalyst fines. The fines were primarily alumina and typically were less than 20 microns in diameter. Such fins can be very erosive, depending on the gas velocity and flow arrangement, thus requiring some careful design considerations.

Vertical firetube units in this particular plant were experiencing numerous mechanical failures, and the exhaust gas temperature was too high. Thus, a water quench was required prior to passing through the gases through an electrostatic precipitator. The firetubes were being cleaned every other shift by scouring the inside of the tubes with walnut shells. Consequently, it was decided to replace these heat recovery units with longitudinal flow watertube exchangers equipped with a crossflow superheater and some type of sootblower. The boilers were designed for high downflow velocity in order to minimize gas-side fouling and erosion since the tubes were designed with longitudinal fins. Because of the pressurized environment, this application seemed well suited for sonic sootblowers. Unfortunately a number of difficulties were encountered and the horns were not effective as cleaning devices.

Even though there had been previous problems with erosion during the scouring of these units with walnut shells, scouring was resumed on a regular

basis. Both the boiler and the superheater were scoured once every three days which maintained the unit sufficiently clean. After one year of operation, the boiler was shutdown for maintenance and inspection. It was found that the horizontal tubes in the superheater, which were subjected to crossflow, had deposited fines up to 1/3-in. thick on the tubes in low flow areas. In high-flow areas, the tubes were clean, polished, and eroded to some extent. However, the boiler showed no evidence of erosion.

From this experience, Krowech observed that higher velocities may be used for flow parallel to surfaces than for flow normal to surfaces in applications where erosion is a concern. In this case it was found that a velocity of 105 ft/sec caused no erosion whatsoever in longitudinal flow. However, at similar velocities the impingement of the catalyst fines polished and eroded the crossflow arrangement to some extent. Consequently, the designer of heat exchangers for gas-side fouling service must estimate two important parameters in order to make the design successful. First, the stable thickness of the deposit determines the fin spacing required to prevent bridging, or touching of the deposits between the fins, which severely degrades the heat transfer. Second, the gas-side fouling factor must be known to properly size the heat-transfer surface area. Thus, the effects of gas velocity, surface orientation, and cleaning techniques may be combined with previous operating experience to design the unit for successful operation.

3.2.2 Regenerators

Regenerators are transient, or unsteady, type heat-transfer devices. There are basically two types of regenerators, the rotating type and the stationary type. In the rotary regenerative heater, shown in Figure 3-10, a rotor is mounted within a box housing. The wheel rotates slowly with the hot gases flowing through one side of the exchanger and the air on the other side in a counterflow fashion. The second type of regenerator consists of a stationary matrix. The hot gases first flow through the matrix to heat it, and the air is then heated as it passes through the same matrix. In other words, the hot and cold fluids alternate in flowing through the heat exchanger. If

the gases are dirty they tend to plug the small passages in the regenerator, so regenerators are generally equipped with both sootblowers and water washing capabilities.

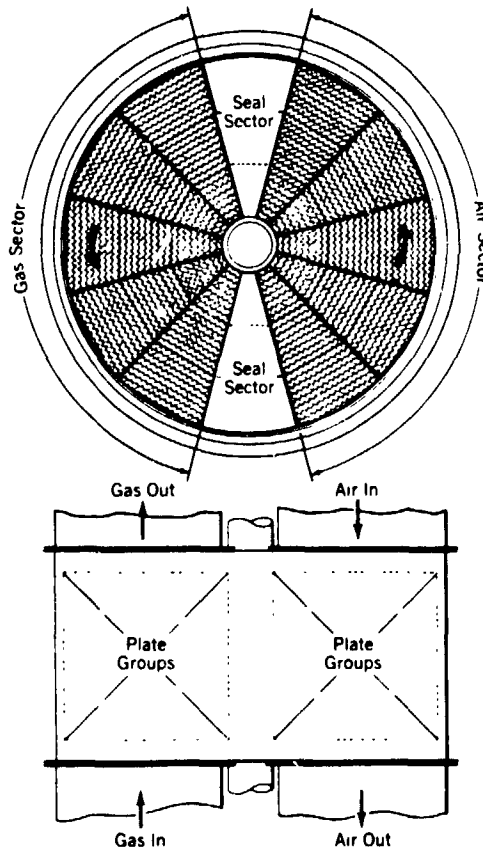

Figure 3-10. The Rotary Regenerator (Reference 3-22)

One very important example of the rotary regenerator is the Ljungstrom air preheater which is widely used to preheat combustion air in boilers. These units are especially vulnerable to gas-side fouling and corrosion due to the condensation of sulfuric acid on the low-temperature end of the unit. An important application involving the stationary matrix type regenerator is found in the glass industry where heat is recovered from melting furnace exhaust gases (Reference 1-14). Due to the high melting temperature of the glass, exhaust gases leave the melting furnace at about 2800 F. Most glass plants use brick-checkers-type periodic flow regenerators to recover heat from these

exhaust gases which is used to preheat combustion air. The exhaust gases leave the checkers regenerator at a temperature of 1000 - 1200 F and are then exhausted to the atmosphere since there is presently no secondary heat recovery being used in the glass industry. The high temperature gases leaving the furnace are extremely corrosive and have a tremendous gas-side fouling potential. The primary constituents in the exhaust gases responsible for fouling and corrosion include SiO_2 , Na_2SO_4 , Al_2O_3 , V_2O_5 , and CaSO_4 . In the top zone of the regenerator, which is the hottest part of the unit, the fouling and corrosion are caused primarily by SiO_2 , V_2O_5 , brick erosion, and large particulates. In the bottom zone of the regenerator SO_3 is the major cause of corrosion and the major cause of fouling is condensed Na_2SO_4 . The typical characteristics of this type of fouling and corrosion include: erosion, formation of sticky eutectics, weakening and crumbling of bricks, deposition of particulates, and the formation of slag. Several methods have been identified and discussed by Webb and Kulkarni (Reference 1-14) to minimize the effects of gas-side fouling and corrosion in glass plants. Among these are the: (a) use of additives such as MgO and carbon, (b) control of operating conditions such as excess combustion air, (c) use of high quality fuels such as natural gas and electric boosting, and (d) batch treatment such as pelletizing, briquetting, moisturizing, and preheating.

3.2.3 Direct Contact Heat Exchangers

Direct contact heat exchangers (DCHX) are units in which the two heat-transfer media come into direct contact, i.e., they are not separated by a solid surface. Because of this unique feature, DCHX units represent one possibility for avoiding, or at least reducing, the effects of gas-side fouling. Applications of this type of exchanger are relatively limited, but two interesting examples are discussed in this section.

Suspension Preheaters

At the present time about one-half of the dry process cement kilns in the U.S. are equipped with suspension preheaters. The Fuller-Humboldt system,

which is widely used in this country, is shown in Figure 3-11 (Reference 3-23). The preheater consists of four cyclones or stages, each of which includes a long riser where the raw feed is carried upward into the cyclone in parallel with the hot gases from the preceding cyclone. Thus, heat is transferred by direct contact between the hot kiln exhaust gases and the cooler raw feed as it is held in a state of suspension. It takes only about 30 seconds for the raw material to pass through the entire preheater as it reaches a temperature of approximately 1475 F. About 45 percent of the total required calcination -- i.e., driving CO_2 from the CaCO_3 to produce CaO , the principal constituent of portland cement -- is achieved in the preheater. In addition, some preheaters are equipped with a precalciner, designated by the letters PC in Figure 3-11, which consists of an auxiliary fuel burning chamber so that a shorter kiln may be used.

Even though the raw feed and the hot kiln gases are not separated by a solid surface, severe buildups do occur on the surfaces of the cyclone separators which requires periodic shutdown for mechanical cleaning. In addition, the vaporized alkalis, sulfates, and chlorides in the hot gases from the kiln can condense onto the raw feed in the preheater and these contaminants are then returned to the kiln where they are re-volatilized and the process is repeated. Thus, a bypass, which is shown in Figure 3-11, is frequently used to limit the accumulation of these impurities in the kiln-preheater system. There is yet another problem which has been encountered in suspension preheaters. Since there is substantial interaction among the various particles in the preheater, they can become electrically charged. Thus, if the gases leaving the suspension preheater are introduced into a heat exchanger such as the gas-to-air unit shown in Figure 3-6, particulates in the gas stream can be deposited onto the heat-transfer surfaces by electrophoresis. A further discussion of these and related problems may be found in References 3-24 and 1-13.

Low-Temperature Direct Contact Heat Exchanger

Heat recovery at temperatures below 300 F is generally avoided because of the gas-side fouling and corrosion problems resulting from the condensation

ORIGINAL PAGE IS
OF POOR QUALITY

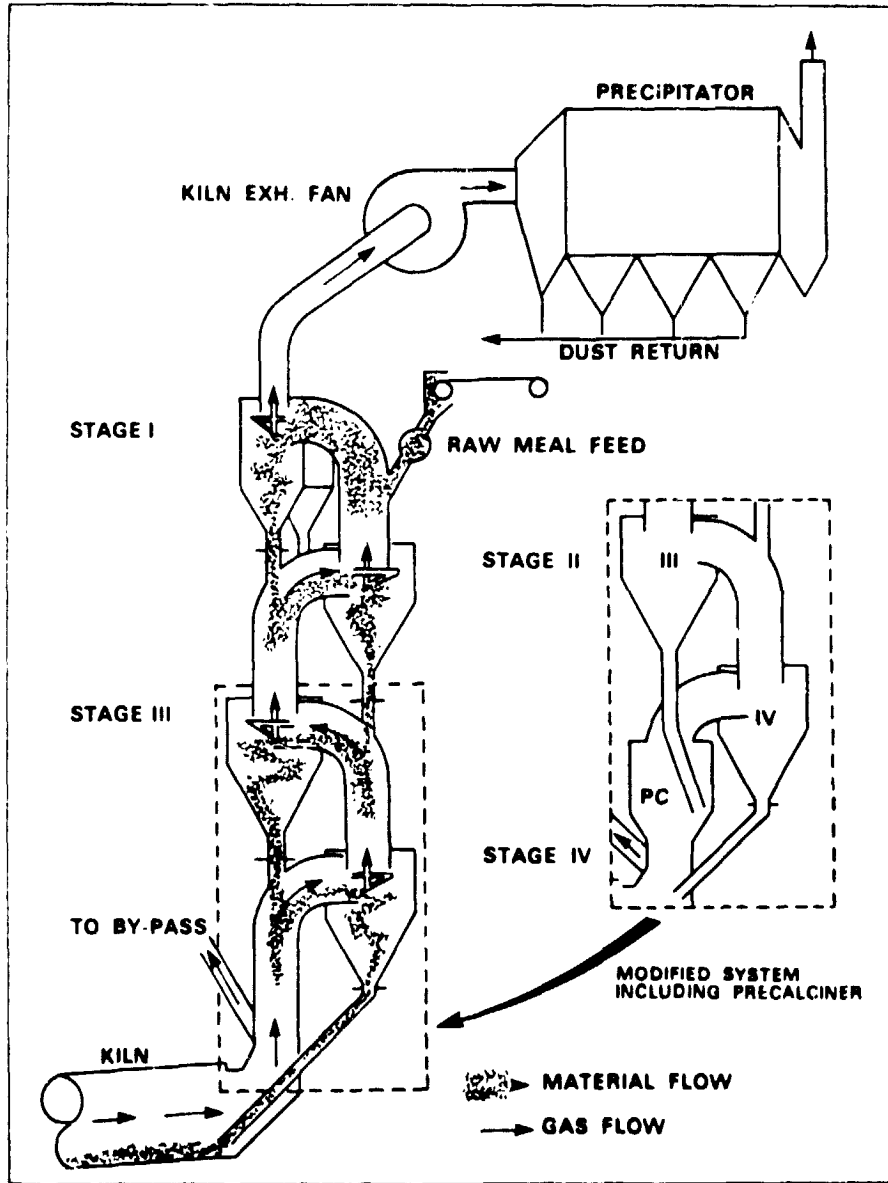

Figure 3-11. Suspension Preheater Used in the Cement Industry
(Reference 3-23)

of acids and water onto metallic surfaces at temperatures below the dewpoints of these constituents. However, much of this low-level energy can be recovered by condensing the water vapor contained in the exhaust gases and using it for feed water heating, air preheating, or for the production of process hot water. While this technique is considered a new one in the U.S., many such installations are presently operating in Europe.

The basic process is illustrated in Figure 3-12 (Reference 3-25). Flue gases typically enter the direct contact heat exchanger at a temperature above 300 F, pass directly through the cold water stream in the spray chamber, and are discharged out the top at 100 to 120 F. The operation is very similar to a cooling tower working in reverse. The hot gases are cooled and the recovered energy is used as a hot water source, as opposed to the cooling tower where air is heated and the hot water stream is cooled. Since the cooling water is now contaminated by the constituents in the exhaust gases, a secondary heat exchanger is normally used to transfer the recovered heat to the process fluid as shown. One big advantage of the DCHX is that there is no resistance to the flow of heat through a solid surface. Thus, a wide variety of fluids can be handled under conditions which would normally cause fouling and corrosion in a conventional heat exchanger.

Corrosion in a condensing unit of this type can usually be prevented by using Type 304 or 316 stainless steel or fiberglass reinforced plastic for the tower pump and secondary heat exchanger. A unique feature of this particular DCHX is that it reduces emissions while recovering energy. For example, SO₂ emissions can be reduced significantly by using an alkaline water spray. KVB, Inc., Irvine, California (Reference 3-26 and 3-27) has recently started marketing in this country a condensation heat recovery unit designed for new or retrofit natural gas-fired boilers and is made entirely of corrosion-resistant Type 316 stainless steel. However, 500 such installations are presently operating in Europe.

One installation in West Germany is located at a slaughterhouse boiler where the hot water is used in the packing process and for washing down the meat processing equipment. In this application the flue gas temperature of 450 F is reduced to about 140 F at full load, allowing incoming plant water to

be heated from 50 to over 100 F. A second example is also from West Germany. A two-stage flue gas heat recovery unit is operating on a 30,000 lb_m/hr boiler in a chemical plant. The flue gas is reduced from 410 to 120 F which is sufficient to raise the inlet feedwater temperature from 50 to 155 F. At the time this unit was installed in 1980, fuel savings were sufficient to provide a payback of just over one year.

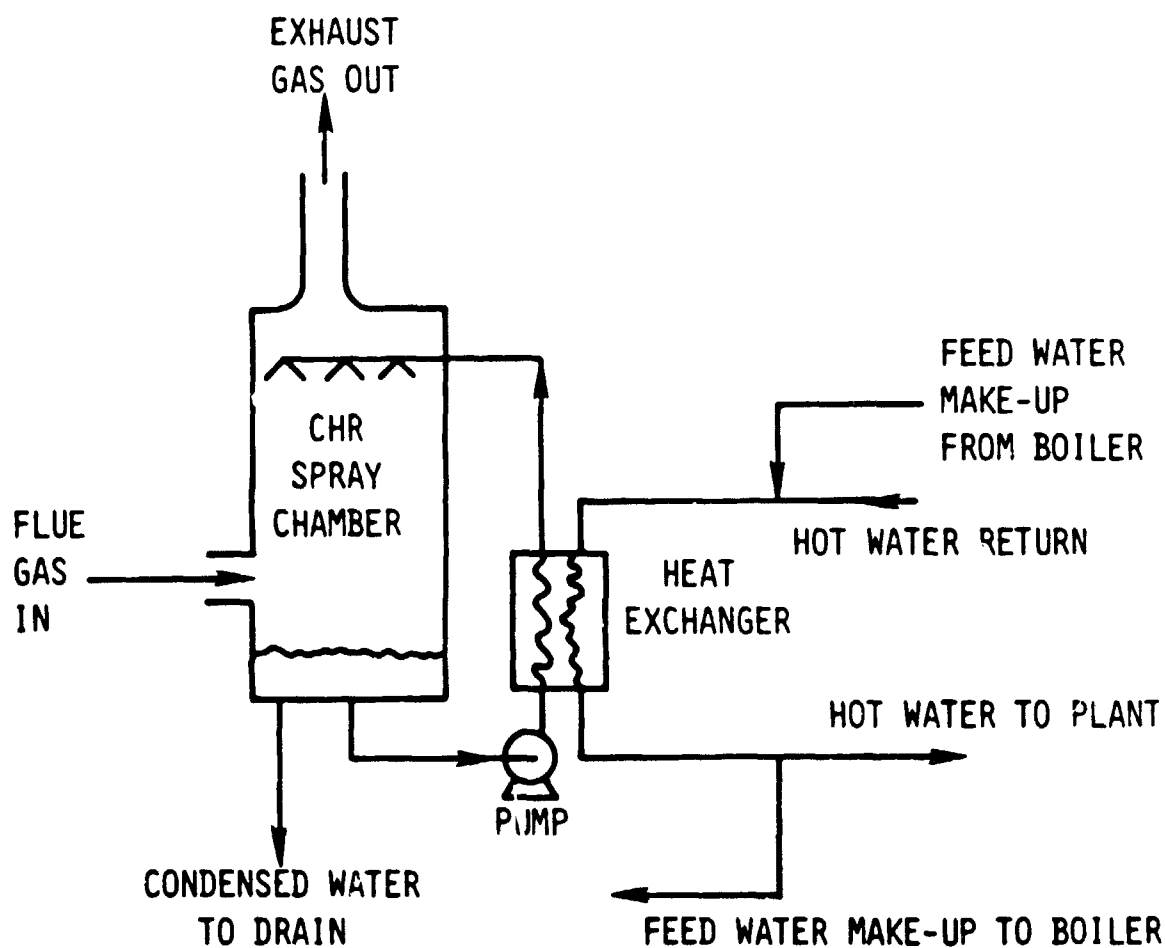

Figure 3-12. Low-Temperature Direct Contact Heat Exchanger
(Reference 3-25)

3.2.4 Fluidized Bed Heat Exchangers

Rudnicki, Mah, and Williams (Reference 3-28) have recently presented an excellent review of fluidized bed heat exchangers (FBHX) for heat recovery applications. In particular, shallow bed FBHXs have been studied extensively in recent years for a variety of heat recovery applications and have been found to be competitive with conventional heat exchangers. In the design of heat exchangers for waste heat recovery, the designer is faced with the limitation of low gas-side heat transfer coefficients. This limitation results in large heat exchanger surface area requirements, and the typical waste heat recovery boiler will have approximately four times more surface area than the typical liquid-to-liquid exchanger for the same duty. Thus, fluidized beds have several potential advantages when used as heat exchangers in heat recovery applications including:

- o Enhanced Heat Transfer (Heat transfer coefficients in fluidized beds can be as much as 20 to 25 times those of gas-side coefficients)
- o Self Cleaning (The solid particulates forming the fluidized bed provide gentle scrubbing to keep the heat-transfer surfaces, including finned tubes, clean)
- o Pollution Control (The fluidized bed can be used as a filter for undesirable particulates in the exhaust gas stream. In addition, the bed material can also be selected to absorb gaseous pollutants such as SO_2)

Stone-Platt Fluidfire, Ltd. in the United Kingdom has developed a shallow bed FBHX as shown in Figure 3-13. The gas flows up through the distributor plate and the bed material, which is typically silica sand or aluminum oxide, and creates a very high gas-side heat transfer coefficient. In this particular design plugging and corrosion of the slots in the distributor plate can be a serious problem. Therefore, chain-driven steel brushes are used to periodically remove the deposits which accumulate.

ORIGINAL PART IS
OF POOR QUALITY

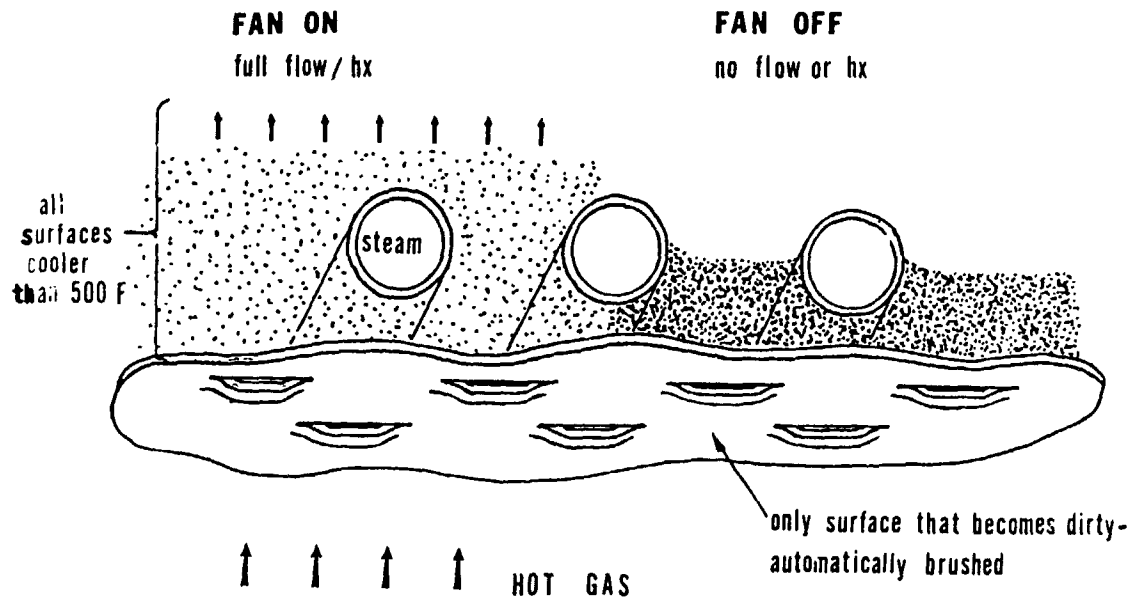

Figure 3-13. A Schematic Drawing of a Fluidized Bed Heat Recovery System (Reference 3-29)

Stone-Platt has designed and installed a FBHX of this type in the Shell International Marine Tanker Fjordshell, a 32,000 ton ship. The unit is installed as a waste heat boiler using the exhaust of the 900 kW Diesel engine used to drive the ship. This unit, the largest industrial fluidized FBHX in operation, has overall dimensions of about 9 ft by 12 ft by 18 ft high. Internally, the boiler has three shallow beds in parallel with a total bed area of almost 325 ft². Steel brushes are used to clean the distributor plate as described above. Stone-Platt has about 20 additional FBHX installations in a variety of industries. Units have been placed in a tunnel kiln exhaust in a ceramic plant, a galvanizing bath exhaust in a steel plant, and a heat-treat furnace in a steel plant. In yet another application, a FBHX functions as an economizer in a chemical plant.

The Aerojet Energy Conversion Company, Sacramento, California, is carrying out a FBHX study in an aluminum remelt furnace exhaust in an aluminum plant in the state of New York (Reference 3-30). A shallow bed unit of the type described previously will be used in this investigation. The fuels used in this particular application are natural gas and No. 6 fuel oil. In addition to contaminants from the fuel, such as vanadium and sulfur in the case of oil, the flue gases contain carry-over from the melt including aluminum oxide, aluminum sulfate, and vanadates. One objective of this study is to determine the gas-side fouling characteristics of the distributor plate in this particular exhaust gas. A second objective is to determine how well the FBHX functions at elevated temperatures, i.e. gas temperatures up to 1800 F. Another aspect of this investigation is to study the gas-side fouling and corrosion characteristics of aluminum remelt furnace exhaust gases using a temperature controlled probe. This device, designed in the shape of a circular cylinder, will consist of nine different segments so that simultaneous information on different materials can be obtained with a single insertion of the probe into the exhaust gases.

3.2.5 Heat Pipe Heat Exchangers

Heat pipes are heat transfer devices which function at essentially isothermal conditions. The heat pipe consists of a sealed tube containing a fluid with a predetermined boiling point. The hot stream boils the heat transfer liquid, filling the tube void with hot vapor. As the vapor moves through the tube into the cold zone, heat is transferred to the cold stream, the vapor is condensed, and the liquid is returned to the hot portion of the tube through a wick material inside the tube. This cycle of vaporizing and condensing continues as long as the tube is exposed to hot and cold streams at each end, respectively. In other words, the heat pipe functions as a boiler with the wick serving as the pump. For heat-recovery applications, a bundle of finned tube heat pipes may be used as indicated in Fig. 3-14 (Reference 3-31). The hot exhaust gases flow over one end of the tube bundle and the air to be heated flows over the other end as indicated.

ORIGINAL PAGE IS
OF POOR QUALITY

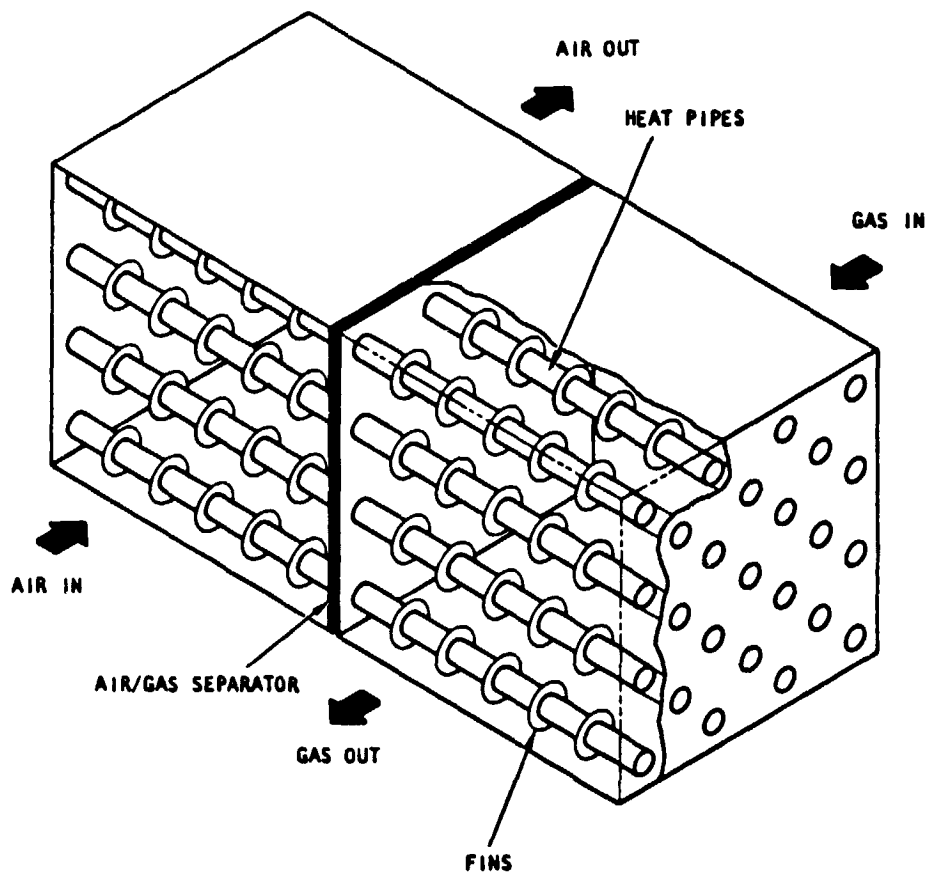

Figure 3-14. Schematic Drawing of a Heat Pipe Heat Recovery System (Reference 3-31)

In late 1979 one of the manufacturing facilities at the Monsanto Chocolate Bayou Plant brought on stream what is thought to be the first large industrial heat pipe application (Reference 3-32). The heat recovery system consisted of finned, steel heat pipes with a naphthalene toluene mixture as the working fluid. The air preheaters were included as part of a major energy modernization project. The facility utilized five natural gas process heaters with a combined heat duty of 150 MM Btu/hr ($1M = 10^3$). All five units were designed to reduce the flue gas exit temperature from 750 F to 375 F. The exchanger heat duties ranged between 4.4 MM Btu/hr and 1.5 MM Btu/hr. The

project also added O₂ analyzers in order to control excess air. The startup was completed in early 1980 with a heat-transfer performance better than expected. After operating for slightly over three years, the units were opened for the first time in June 1983 for inspection and water washing. There was no observable change in appearance on either side, although a 15 percent degradation had been observed in heat-transfer performance. However, it was felt by Monsanto personnel that this deterioration was probably more of an operating condition change than a reduction due to fouling. A quantity of dirt, about two hard hats full, was found in the bottom of the combustion air duct. It may have been on the heat pipes, falling off due to static charge dissipation and mechanical vibration during duct disassembly, a 36-hr process. The furnaces with the heat pipes also experience particulate fouling in the convection section. The particulates, which are refractory and iron oxide from the firebox, accumulate at the root of the fins but do not degrade the thermal performance.

3.3 MATERIALS CONSIDERATIONS

The specification of materials for use in industrial heat-transfer equipment for gas-side fouling service is a very important design option. The characterization of the combustion gases -- including the gaseous species, temperature, velocity, particle loading, particle composition, and particle size distribution -- is a very important consideration in selecting the proper material. Certain gas-side fouling deposits can be highly corrosive even at low temperatures, and combustion gases with abrasive particles can cause severe erosion if proper precautions are not taken. The temperature level, in particular, is a very important parameter because in most cases the deposition processes which take place depend on both the gas temperature and surface temperature. For purposes of discussion, the topics considered in this section are divided into three regimes as was discussed in Section 1: (a) low-temperature range, $T_{\text{gas}} < 500 \text{ F}$, (b) intermediate-temperature range, $500 \text{ F} < T_{\text{gas}} < 1500 \text{ F}$, and (c) high-temperature range, $T_{\text{gas}} < 1500 \text{ F}$.

3.3.1 Low-Temperature Range, $T_{\text{gas}} < 500 \text{ F}$

The classical problem in this regime is the so-called acid and water dewpoint condensation problem. Oil, coal, and many other fuels contain sulfur. The sulfur in the fuel combines with the oxygen in the air during combustion to form sulfur dioxide, SO_2 , and if there is sufficient excess air sulfur trioxide, SO_3 , will also be formed. The SO_3 can combine with water to form sulfuric acid, H_2SO_4 , which condenses onto heat transfer surfaces if they are below the acid dewpoint temperature. Under normal operating conditions the sulfuric acid dewpoint ranges from about 240 to 280 F, depending upon the amount of SO_3 in the gases. At lower surface temperatures water will condense onto the surface in the range of 110 to 150 F. In the latter case the water can combine with the SO_3 to form sulfurous acid, which like H_2SO_4 , can be highly corrosive. In most applications, surface temperatures are maintained above the water dewpoint temperature, but the acid dewpoint condensation is a serious problem in low-temperature heat recovery applications. Some of the ways to combat this problem are discussed in this section.

Predicting the Acid Dewpoint Temperature

Shown in Figure 3-15 is a plot of the Acid Dewpoint Temperature of combustion gases from fuel oil as a function of the percentage of sulfur in the fuel (Reference 3-33). Also shown on the plot, along with some representative experimental data, is the API RP 533 (Reference 3-34) recommendation for air preheaters. Clearly, the API recommendation falls on the high side of the data. In other words, if this guideline is used for design purposes, the system will probably not encounter dewpoint condensation problems because the predictive method is on the safe side. On the other hand, the use of the criterion will lead to conditions where the heat recovery equipment is operating at a higher surface temperature than necessary, thus exhausting hot gases to the environment which still contain recoverable energy. That description describes the dilemma which faces the designer: (a) the surface temperature should be above the dewpoint temperature to avoid acid condensation problems, and (b) the gas temperature should be as low as possible in order to recover as much energy as possible. Some of the techniques which have been developed to deal with this problem will now be considered.

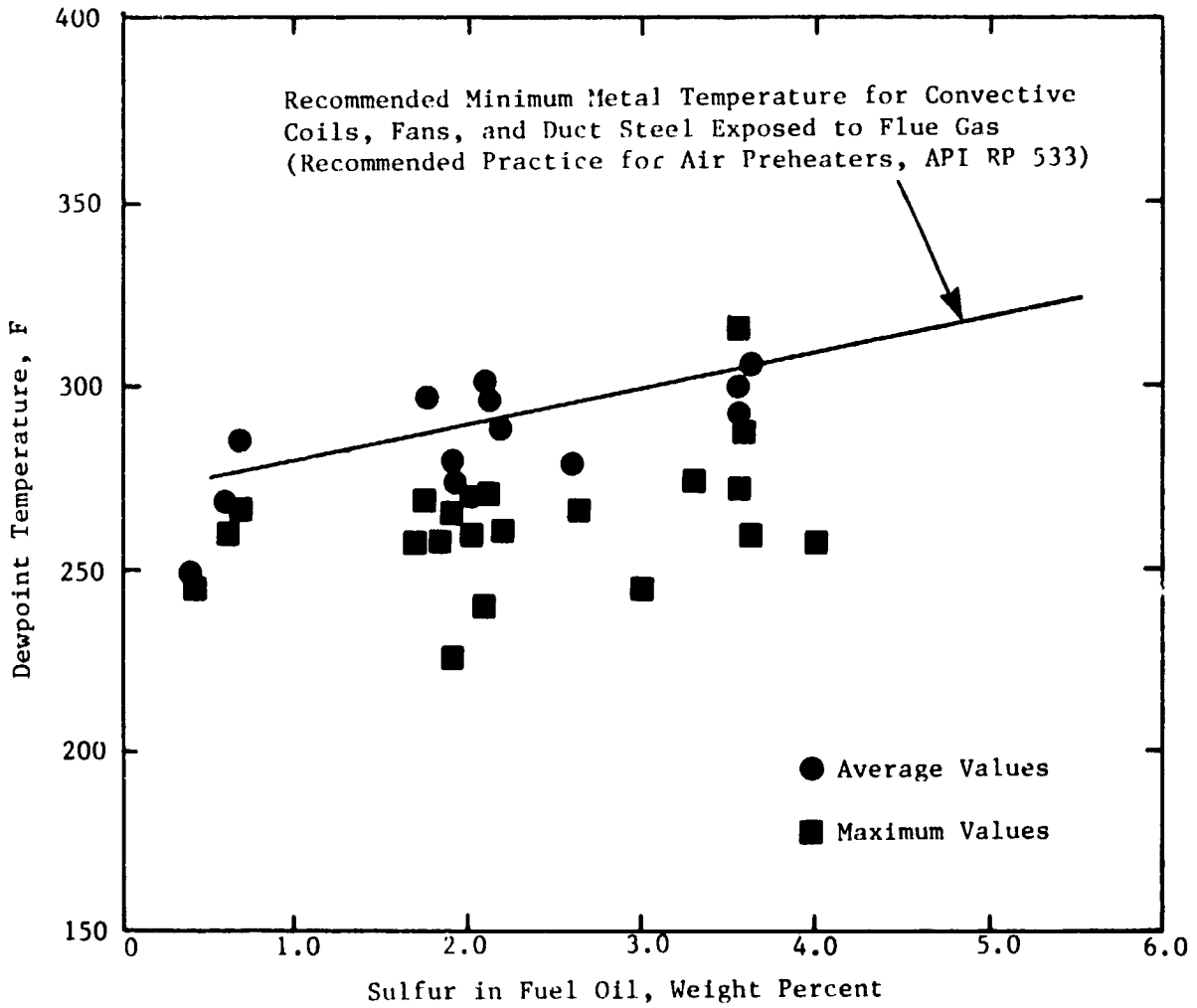

Figure 3-15. Acid Dewpoint Temperature of Combustion Gases from Fuel Oil as a Function of Sulfur Content (Reference 3-33)

Cold End Corrosion in the Ljungstrom Preheater

Ljungstrom air preheaters are rotary type regenerators used widely to preheat combustion air. Sotter (Reference 3-35) has pointed out that many regenerative type preheaters are in poor condition because of corrosion and thus a typical life of these units is about two years. Corten, which has good corrosion resistance, is the most commonly used material in air preheaters, but Type 409 stainless steel is also used to some extent. C E - Air Preheater, a subsidiary of Combustion Engineering, used porcelain enameled heat transfer surfaces in oil-fired applications so that the surface temperatures may be operated below those which are safe for metallic materials (Reference 3-36). It should be pointed out that cold end corrosion is a greater problem in oil-fired systems than in coal-fired systems because: (a) the vanadium in residual oil-ash deposits acts as a catalyst in converting SO_2 to SO_3 , and (b) the ash in flue gases tends to reduce the amount of SO_3 vapor in the gases, but there is considerably less ash in oils than in coal.

Coatings to Resist Cold End Corrosion

Miller et al. (Reference 3-37) at Argonne National Laboratory carried out a survey on the possible use of plastic heat exchangers for situations such as the acid dewpoint problem. Among the advantages of plastics in such an application are: chemical inertness, versatile fabrication methods, moisture resistance, and corrosion resistance. They concluded that the following three candidates should be selected for further investigation: (a) polytetrafluoroethylene (Teflon), (b) polyphenylene (Ryton), and (c) polyvinylidene fluoride (Kynar). Of these three, it was concluded that Teflon was the leading candidate. AiResearch (Reference 3-13) carried out a laboratory study by placing various samples in a concentrated bath of H_2SO_4 and confirmed the findings of Argonne, namely that Teflon, Ryton, and Kynar would all be good candidates for coatings on heat exchanger surfaces for use in applications where cold end corrosion is a potential problem. However, it was pointed out that sharp edges, burrs, and other protrusions must be removed by filing, blasting, peening, pickling, etc. before a coating could be successfully applied.

Dyer (Reference 3-38) has reported that Kentube applied a ceramic coating on finned tubes for a cold end corrosion application. The surface was mechanically cleaned, pickled, and then dipped in a bath to apply a coating of about 1 - 2 mils thick. However, the coating was prone to chip and it was also determined that it was not effective in abrasive environments. The response of this material to thermal shock was not determined.

Weierman (Reference 3-39) has reported the use of hot-dip galvanizing on the outside of a carbon-steel finned-tube bundle to resist corrosion. In this particular application water spray was used on the exterior of the tube bundle to enhance the heat transfer by evaporative cooling. The water inside the tubes was used to cool foundry equipment.

Glass-Tube Heat Exchangers

Glass-tube heat exchangers show considerable promise for applications in low-temperature heat recovery systems where gas-side fouling and corrosion are potential problems. The operating experience of glass-tube heat exchangers manufactured by two different firms are reported here. Most of the installations to date have been in Europe, although a few units have now been installed in this country.

Air Froehlich has developed a glass tube recuperator in the United Kingdom for use at gas temperatures below 500 F. These recuperators, which have excellent resistance to corrosion, have been used in a variety of applications in the textile, ceramics, foodstuffs, chemical, and pulp and paper industries as indicated in Table 3-1 (Reference 3-40). One interesting example of an Air Froehlich recuperator which has been in operation for several years is an installation in a textile plant.

In a textile finishing machine with cylinder dryers, fumes and vapor are extracted through a hood over the dryer section and then exhausted to the atmosphere. These exhaust gases must be replaced by outside air preheated to a temperature of 68 - 77 F for working space ventilation. In order to avoid

Table 3-1. Air Froehlich Glass Tube Recuperator Applications (Reference 3-40)

Industry	Process Description	Exhaust Gas Temperature (F)	Exhaust Gas Impurities	Average Yearly Operating Time (hr)
Textile Finishing	High-temperature air drying of printed textiles	160-320	Dyestuff urea fibres	2500
	High-temperature thermofixation	300-480	Fibers resin	4000
Ceramics	Drying and granulating with spray dryers	120-300	Ceramic powder combustion impurities	6000
Food	Powderization of milk, coffee, potatoes, etc. with spray dryers	140-285	Powder	8400
Chemical	Powderization of coloring agents	200	Powder	4000
Brewing	Kiln-drying of malt	70-160	Dust, combustion impurities	4000
Pulp and Paper	Pulp and paper drying	140-200	Pumping fibres	5000
Fertilizer	Drying of animal dung	195-230	Dust, partially moist	6000
Fodder	Grass drying with cylinder	195-200	Dust graphite	3000
Wood	Pressboard chip drying	250-300	Wood-dust resin	4000

overheating the plant during the warmer periods of the year, the supply air temperature is controlled by a bypass in the exhaust gas duct. In this particular plant it was decided to heat the air using the exhaust gases in a glass-tube recuperator.

The gas-side fouling potential of the dryer hood exhaust gases was the principal reason for selecting a glass-tube exchanger. These gases contain dust, fibers, and sticky components from the finishing process which tend to deposit on the outside of the tubes near the inlet, or coolest, side of the unit. In order to clean the exchanger, a permanently installed sprinkler nozzle is used to flush the deposits away from time to time. The absence of gas-side fouling problems in the application was attributed to the fine surface structure of the glass, the high gas velocity over the surfaces, and the periodic cleaning of the heat-transfer surfaces.

Corning Glass Works (References 3-41, 3-42) has recently developed modular gas-to-gas to gas-to-liquid heat recovery systems for the recovery of low grade energy, i.e., gases with maximum temperatures of 500 - 550 F. At the present time these units are limited to maximum operating gas temperatures of about 500 to 550 F because of limitations in sealing techniques which currently utilize a special elastomer. However, Corning would like to raise this limit to about 800 F through the development of ceramic seals.

The "Pyrotherm" systems are assembled from modular banks of Pyrex brand borosilicate glass tubes with stainless steel headers with the dirty gases always on the tubeside. Tube diameters are typically 1.0 in. with a 0.030-in. wall thickness. Although the thermal conductivity of the Pyrex tubing is lower than most metals used in heat exchangers, the inner and outer gas-side convective heat transfer coefficients control the overall heat transfer process. Since these coefficients have nearly equal values regardless of the tube material, the difference in the overall heat transfer coefficient between metal and glass is typically less than four percent in the gas-to-gas units.

Corning presently has about 30 such heat recovery units onstream in Europe and five in the United States. Typical applications include spray drying exhausts in the food, dairy, and chemical industries. For example, one application deals with cheese whey in the dairy industry. Corning claims energy savings of up to 30 percent in situations where these exchangers are employed. Since glass, stainless steel, and silicone elastomers -- the components in these heat exchangers -- are all highly resistant to low-temperature corrosion, these heat recovery systems are especially suited for

applications involving dirty, moist, or corrosive gases. Thus, it is possible to operate these systems below the acid and water dewpoint temperatures with minimum difficulties. Cleaning, when necessary, is carried out either online or off-line, depending on the customer's preference. For example, in the dairy industry two hours of each 24-hr day are typically utilized for cleaning purposes. Cleaning techniques used to date include an automatic spray system using either hot water or acid, or both. However, gas-side fouling has not been a major problem in the applications where these units have been used. Depending upon the specific operating conditions, typical payback periods are between two and three years, although in some cases as little as 6 months is required.

Other energy intensive industries, such as steel or glass manufacturing, are also candidates for glass-tube exchanger applications at intermediate temperature levels, provided that the ceramic seal technology can be perfected. Corning Glass is also working with the Gas Appliance Technology Center with an eye toward using this type of exchanger in appliances where low-temperature gas-side fouling and corrosion are potential problems.

Corrosion-Resistant Low-Finned Tubes

Another design option which is available is the so-called low-finned tube. This type of tube has external integral fins with typically 19 - 30 fins/in., fin heights of 0.030 - 0.040 in., and a finned-to-plain-tube area ratio on the order of two to three. Such tubes have been available for years in copper (Reference 3-43) and are now also available in carbon steel and several stainless steels and superalloys (Reference 3-44). As yet, the fouling and corrosion service has not been critically tested. However, one very interesting application in which low-finned tubes are currently being used will now be described.

In some applications effluent gases from burned coal are scrubbed to remove sulfur oxides and particulate matter using a flue gas desulfurization (FGD) process. During this scrubbing operation the gases are cooled and become saturated with water vapor to such an extent that they must be reheated in

order to exhaust the gases from the stack. One popular method for accomplishing this reheating is through the use of either steam-or-water-heated tube bundles. Although most of the interest in FGD systems to date has been associated with the electric utilities, this process will also become of greater interest to the non-utility industries as the use of coal continues to increase.

Inline reheat systems consist of an inline tube bundle installed in the gas duct downstream of a mist eliminator. The heating medium can be either steam or hot water and the exchanger tubes are usually made of carbon steel, Corten, Types 304, 316, 316L and 317L stainless steel, Hastelloy G, Inconel 625, or combinations of these materials. Unfortunately, these systems have been subject to both gas-side fouling and corrosion. In some cases the corrosion has been so severe that even the alloys listed above have been unsatisfactory. Some installations have utilized high-finned tubes with 3 fins/in; however, such tubes tend to foul or plug more than bare tube bundles (Reference 3-45).

In an attempt to overcome some of these operating difficulties, a FGD system employing steam heating inside integral, low-finned tubes has recently been installed at the Northern Indiana Public Service Company (NIPSCO) in Wheatfield, Indiana (Reference 3-46). The tubes were manufactured by High Performance Tube, Inc., Union, New Jersey. They were made of Inconel 625 with the following dimensions: 30 fins/in., 0.75-in. OD, 0.012-in. fin thickness, 0.032-in. fin height, and finned-to-plain-tube area ratio of 2.65. The tubes were arranged on an inline layout and were equipped with air-driven sootblowers.

The NIPSCO unit went onstream in April 1983 and has been up and down since then due to a variety of boiler-related problems. However, it appears that the reheat system, including the sootblowing operations, is functioning properly. The long-term operation of the system under the severe gas-side fouling and corrosion environment to which it is subjected remains to be seen (References 3-47, 3-48). It is hoped that this low-finned exchanger will perform satisfactorily based on the expectation that: (a) the same amount of reheat can be accomplished with about half the number of plain tubes,

(b) fewer tube rows allow for better cleaning with the sootblowers, and
(c) fewer tube rows result in a reduction in the crossflow pressure drop in comparison to plain tubes. If this application is successful, it could enhance the use of high performance low-finned tubes, rather than plain tubes, in other applications where gas-side fouling and corrosion are potential problems.

Economizer Preheat System

In many cases the current engineering design practice is to maintain the surface temperature of the heat exchanger sufficiently high to avoid the cold-end corrosion problem. One common procedure used on boiler economizers is to preheat the feedwater to ensure that the surface temperature of the economizer remains above the acid dewpoint temperature at all times. One such system is described here.

Kentube [Dyer (Reference 3-38)], a designer and manufacturer of economizers used in industrial boilers, has incorporated a feedwater preheat system into their standard economizer design. A shell-and-tube heat exchanger is normally used for this purpose with steam from the boiler used to preheat the feedwater. The amount of steam required for the proper preheat is regulated by a temperature control valve which accommodates a variety of low- and high-sulfur fuels. As the feedwater temperature entering the economizer decreases, as would be allowable with low-sulfur fuels, the greater the temperature difference between the steam and the water and hence the greater the heat transfer. On the other hand, a greater margin of safety against cold-end corrosion may be achieved by increasing the feedwater temperature of the water entering the economizer. Thus, by means of an auxiliary heat exchanger, the designer is able to completely avoid the problem of cold-end corrosion in economizers.

3.3.2 Intermediate-Temperature Range, $500\text{ F} < T_{\text{gas}} < 1000\text{ F}$

A number of important heat-exchanger applications where gas-side fouling and corrosion are potential problems occur in this temperature range.

Coal-fired boilers certainly represent a very important application in this range, perhaps the most important one. Two additional examples are also considered.

Coal-Fired Boilers

Bryers (Reference 1-5) has pointed out that liquid deposits on the surfaces of coal-fired steam generators can be highly corrosive. All such liquid attacks observed thus far have been associated with the presence of alkali and sulfur compounds. The temperature ranges in which accelerated corrosion takes place can be related to the melting temperatures of those various compounds, i.e., about 550 to 900 F. In the presence of a reducing atmosphere, corrosion may be attributed to the pyrosulfates $\text{Na}_2\text{S}_2\text{O}_7$ and $\text{K}_2\text{S}_2\text{O}_7$. The iron-alkali trisulfates $\text{Na}_3\text{Fe}(\text{SO}_4)_3$ and $\text{K}_3\text{Fe}(\text{SO}_4)_3$ have been primarily responsible for the severe loss of metal in superheaters and reheaters where the metal temperature is in the range of 1100 to 1300 F. A difference of opinion centers around the source of Fe_2O_3 in the alkali-iron trisulfate and therefore the exact mechanism of tube wastage. Some think coal ash is the source while others think that tube scale is the more likely form of Fe_2O_3 . The third and highest temperature range ($T_{\text{gas}} > 1500$ F) is associated with sodium and potassium sulfates which are highly corrosive when molten. However, this type of alkali sulfate corrosion has not been a problem in most heat-transfer equipment in boilers because the temperature at which it would occur is not reached by the metal parts in steam generators (Reference 1-5). Carbon steels are reasonably resistant to scaling in combustion atmospheres up to about 1000 F, but may suffer accelerated oxidation at somewhat lower temperatures under high states of stress. Therefore, carbon steel tubing in the superheaters is restricted to moderate temperatures, while stainless steels and superalloys are used for more severe conditions.

Low-Sulfur-Content Corrosion

For heat recovery units in fired-heater operations, the major concern expressed by Meith (Reference 3-33) is the sulfur corrosion which occurs in exhaust gases from fuels with low sulfur content (less than one percent by

volume as H₂S) at intermediate temperature levels (500 - 700 F). Such corrosion has been a major problem with carbon steel as the exchanger material. Therefore, ENTEC has developed the following design procedure for exchangers operating in such a service. A "muffler steel", which contains 11 percent chromium, is used in finned-tube bundles, with the first two or three plain-tube rows, rather than finned tubes, designed to shield the finned tubes. In addition, Meith feels very strongly that increasing the fin thickness is not a solution to the corrosion problem. He strongly recommends that no fin should be thicker than 0.050 in. If a thicker fin is required because of corrosion, then the material should be changed. Grove, on the other hand, suggests that the fins should be as thick as possible (Reference 3-49) and gives three reasons: (a) thicker fins are only nominally more expensive than thinner fins, (b) thicker fins are more erosion and corrosion resistant than thin fins, and (c) increasing the fin thickness increases the fin efficiency and hence the heat transfer.

Battelle Columbus Laboratories (BCL) has been engaged in a long-term study to determine the gas-side fouling and corrosion problems resulting from the incineration of a variety of municipal solid wastes. The most recently reported effort in this area was concerned with the effects of burning a mixture of refuse and sewage sludge in a municipal incinerator in Harrisburg, Pennsylvania (Reference 3-50). The refuse consisted of a great variety of materials, including paper, wood, grass, garden waste, cloth, garbage, plastics, dirt, glass, ceramics, and some metals. An analysis of the sludge showed an average value of 3.4 percent sulfur and 0.09 percent chlorine. The effects of exposure time, metal temperature, and gas temperature were investigated. The major results obtained in this study are:

- (a) The corrosiveness of the refuse combustion environment to carbon steel as indicated by 8-hr exposures was only one-half as great with sewage sludge present. Less reduction occurred with Alloy T22, very little with Incoloy 825, and essentially none with Types 310 and 347 stainless steel.
- (b) The corrosion resistance of alloys to the refuse-sludge combination in decreasing order was Incoloy 825, Type 310

stainless steel, Type 347 stainless steel, Type T22 stainless steel, and Type A106 carbon steel. In addition, an aluminized coating on steel remained intact during the exposures and could be a cost-effective alternative.

- (c) The corrosion rates decreased with exposure time in the presence of sewage sludge and appeared to level off at about 1000 hours.
- (d) For carbon and low alloy steels the corrosion rates increased with metal temperature in the range 500 - 900 F, while those for stainless steels decreased.
- (e) The short-term corrosion rates at gas temperatures of 1100 - 1200 F were only 1/5 as great as at 1500 F and showed less increase with metal temperature.

During this long-term effort by BCL to study the burning of municipal wastes, the overwhelming factor they found is the chloride attack which can be quite severe and which occurs under both oxidizing and reducing conditions.

3.3.3 High-Temperature Range, $T_{\text{gas}} > 1500$ F

The high-temperature regime is characterized by extremely hostile exhaust gases. The topics considered here include the development of ceramic heat exchangers and the impact of gas-side fouling and corrosion on materials used in high-temperature heat recovery in the aluminum and glass industries.

Ceramic Heat Exchanger Development

The Gas Research Institute (GRI), Chicago, Illinois, is carrying out a 3-year study to develop a ceramic recuperator and burner system to recover waste heat from several high-temperature industrial furnace exhaust streams with gas temperatures up to 2500 F. A closely-related ceramic heat exchanger development program -- the high temperature burner-duct-recuperator heat



exchanger development (HTBDR) program -- is being sponsored by the DOE Office of Industrial Programs. The prime contractor for both of these projects (Reference 3-51) is the AiResearch Manufacturing Company, Torrance, California.

The major objectives of the GRI effort are to design, develop, fabricate, field-test, and establish the commercial feasibility of an advanced, high-temperature ceramic recuperator and a high temperature combustion air burner (Reference 3-52). The burner will operate with a combustion air preheat up to 2000 F, using either gas or No. 2 fuel oil. A detailed design of a 5 MM Btu/hr prototype recuperator has been completed. The unit consists of a tubular ceramic heat exchanger operating in series with an AiResearch metallic plate-fin heat exchanger (which was described earlier in this section). The ceramic heat exchanger is a 2-pass tubular unit with the flue gases flowing over the exterior of the tubes which are arranged on a 1.5-in. equilateral layout. The ceramic tubes are 48 in. long, and have inside and outside diameters of 0.75 and 1.00 in., respectively.

One preliminary task related to gas-side fouling has been carried out. This effort was concerned with the environmental compatibility of the candidate materials with typical industrial flue gases. The purpose of this portion of the study was to aid in the selection of the shell-and-tube materials for the prototype recuperator which will be tested. Materials subjected to these environmental tests included sintered α -SiC, siliconized SiC, Si₃N₄-bonded SiC, recrystallized SiC, and chemical vapor-deposited SiC. The tube samples were immersed in several exhaust gas streams including those from a steel soaking pit, a steel forge furnace, an aluminum remelt furnace, and a steel reheat furnace. The samples were exposed to flue gases up to 2425 F for periods up to 185 days. Except for the tests in the exhaust from the aluminum remelt furnace, which covered the tube samples with a glassy coating, the exposed materials seemed to withstand the high temperature environments in reasonably good condition. However, these tubes were tested under isothermal conditions. More critical environmental tests to determine the impact of gas-side fouling during heat recovery operations will be carried out later.

The Corrosion Response of Materials for High-Temperature Heat Recovery
in the Aluminum Industry

Another high-temperature area which GRI is actively pursuing is that of heat recovery in the aluminum industry (Reference 3-51). Although natural gas and Diesel fuel are the fuels most widely used, the exhaust gases from the aluminum remelt furnace also contain impurities by the contamination resulting from additives to the melt. The most severe environment in the aluminum remelting process is that above remelting pots where halide fluxes are used to remove surface oxides and chlorine gas is used for alloy sparging. A typical flux will contain potassium and sodium chloride to provide a low melting material (1100 - 1200 F) in which to dissolve the fluoride salts. The fluorides are the active material in affecting oxide removal. The GRI program has been concentrating on this area.

Solar Turbines Incorporated (Reference 3-53) has recently completed a study for GRI in which 21 different stainless steels, superalloys, and ceramics were analyzed for corrosion in the aluminum remelt furnace environment described above. A 60-in. high test chamber was constructed and attached to the side of the exhaust stack in an aluminum remelt furnace. Test probes of 0.75-in. diameter for the metals and 1.00-in. diameter for the ceramics were tested in the chamber. The probes were each two to three feet in length, and most of them consisted of four different materials. The materials tested are indicated in Table 3-2. The stack temperature was nominally 2000 F maximum and the uncooled ceramic samples were tested at this temperature. The stainless steels and superalloys were air cooled and were tested at nominal maximum surface temperatures of 1200, 1500 F and 1500, 1700 F as indicated in Table 3-2 (except for the INCO 800 which was tested at 1000 F). The duration of the tests ranged from a minimum of 315 hr to a maximum of 2448 hr.

Very high rates of tubewall recession were experienced by all metal-alloy candidates (1200 - 1700 F) and SiC ceramic candidates (2000 F), with no evidence seen of reliably viable, intrinsic protection in any of the material designs at the temperatures tested. The agents causing the high recession and aggressive attack are believed to be the alkali-metal halides entrained in the

Table 3-2. Materials Tested for High-Temperature Heat Recovery in the Aluminum Industry (Reference 3-53)

Material	Desired Maximum Test Temperature (°F)	Duration (Hours)	Remarks
<u>Stainless Steels</u>			
SA-28	1200, 1500	315, 1003, 1318	Sandvik Steel
20CB3	1200, 1500	315, 1003, 1318	Carpenter Steel
310	1200, 1500	315, 1003, 1318	
321	1200, 1500	315, 1003, 1318	
317	1200, 1500	315, 1003, 1318	
RA-330	1200	1128	Rolled Alloys
<u>Superalloys</u>			
Hastelloy X	1500, 1700	315, 1003, 1318	
Hastelloy G	1500, 1700	315, 1003, 1318	
INCO 625	1500, 1700	315, 1003, 1318	
INCO 825	1500, 1700	315, 1003, 1318	
INCO 671/800H	1500, 1700	315, 1003, 1318	
Clad	1500, 1700	315, 1003, 1318	
INCO 690	1500, 1700	315, 1003, 1318	
INCO 800	1000	1128	
<u>Ceramics</u>			
NC-430	Stack Temperature	1318, 2448	Norton SiC
Hexoloy SA(A)	Stack Temperature	1318, 2448	Carborundum SiC
Hexoloy SA(B)	Stack Temperature	1318, 2448	Carborundum SiC
Coors SiC	Stack Temperature	1318, 2448	
TiB ₂ "MSRN-T"	Stack Temperature	1318	Carborundum titanium diboride
TiB ₂ "MSCM-TA"	Stack Temperature	1318	Carborundum titanium diboride
Hexaloy KK-01	Stack Temperature	1318	Carborundum siliconized SiC
Cryston	Stack Temperature	1128	Norton nitrided bonded SiC

recuperator flue gases. These molten halides foul on tube surfaces and are oxidized to form the potent secondary reactants, HCl and Cl₂. Analogous and equally reactive fluorine-containing compounds may also form. On all the metal alloy surfaces these gases rapidly consume the major alloy constituents (Fe, Ni, Cr) to first form molten mixtures of their chlorides, followed by a voluminous formation of their corresponding oxides. Equally severe sulfidation-type reactions were also detected on the nickel-base alloys, Incoloy 825 and Hastelloy S. On the SiC ceramic surfaces, the same HCl and Cl₂ (and analogous HF + F₂) reactants are postulated to generate very volatile SiCl₄ and SiF₄ vapors, which not only consume the silicon-base matrices and binders, but also weaken the residual surface structures by disrupting SiX/SiX and other inter-particle bonds. Subsequent surface cracking and spalling of weakened SiC materials contribute materially to the high rates of recession.

The Impact of High-Temperature Gas-Side Fouling and Corrosion in Glass Plants

Most glass plants use brick-checkers-type periodic flow regenerators to recover heat from the 2800 F exhaust gases leaving the melting furnace. These high temperature gases are extremely corrosive and have a tremendous gas-side fouling potential. Webb and Kulkarni (Reference 1-14) have reviewed the fouling and corrosion problems which take place in: (a) the top part of the regenerator, and (b) the bottom part of the regenerator.

Top Zone of Regenerator (2550 - 1830 F)

- (a) Bricks are eroded by the high temperature flow of gases. Particulate carry over from the furnace (made up of Na₂O, SiO₂, Al₂O₃, V₂O₅, CaO, and cullet dust) along with the eroded bricks tends to settle in the packings and partially block the flow.
- (b) MgO in magnesite bricks reacts with SiO₂ from furnace exhaust to form forsterite (Mg₂SiO₄). This leads to volume expansion and subsequent crumbling of bricks.

- (c) Alumznosilicate bricks, used in earlier regereators, can be attacked by K_2CO_3 and Na_2SO_4 . Also, CaO can be converted to $CaSO_4$ by the attack of SO_3 at temperatures as high as 2370 F. These reactions make the bricks weak.
- (d) Vanadium oxide, V_2O_5 , which comes mainly from fuel oil, and Na_2SO_4 in the flue gas, have been found to attack the bonding material of refractories. The conversion of MgO and CaO to sulfates by SO_3 is accelerated by both V_2O_5 and Na_2SO_4 , and the silica is also fluxed by the vanadium. The reactions leave behind a liquid phase between MgO grains, lower the melting temperature of bricks, and subsequently the bricks begin to crumble.

Bottom Zone of Regenerator (1830 F -1100 F)

- (a) Sodium sulfate (Na_2SO_4), which is formed by the combination of Na_2O and SO_x gases, is a liquid above 1625 F, and some of it is deposited on the bricks. The liquid phase Na_2SO_4 is not corrosive by itself; however, it dissolves SO_3 to form a dilute solution and transmits the SO_3 activity from the gas phase through the molten sulfate to the refractory surface. MgO in magnesite bricks continues to be attacked by the SO_3 to form $MgSO_4$; also, CaO in the silicate bond of the magnesite bricks is converted to $CaSO_4$. These two reactions weaken the bricks:



- (b) The sulfates $MgSO_4$ and $CaSO_4$, formed as mentioned above, dissolve in liquid Na_2SO_4 to form a ternary eutectic around 1200 F. The eutectic drips down the bricks and probably forms white slag after cooling when gas flow is reversed.
- (c) The Na_2SO_4 not deposited on the bricks as liquid, condenses as white fluffy powder in the gas stream below its condensing point

of 1623 F. These particulates, along with the white slag which has dripped from the higher temperature zone, plug up the passage ways in the regenerator packing in the bottom portion. After several passage ways are plugged up, the furnace has to be shut down, and these fouling deposits removed manually.

- (d) There is also a possibility of the formation of alkali iron trisulfates by the reaction of Na_2SO_4 , K_2SO_4 , and Fe_2O_3 deposits, and sodium vanadates by the reaction of Na_2SO_4 and V_2O_5 that are present in the exhaust. These compounds, i.e. sodium trisulfates and vanadates, are corrosive.

3.4 SUMMARY

The design of heat-transfer equipment for gas-side fouling service involves a consideration of many different variables. First, the use of gas-side fouling factors is widely used to oversurface heat exchangers but is only a partial solution since cleaning devices must generally also be specified in conjunction with the burning of dirty fuels. Second, the designer has a wide choice of heat exchanger types available for gas-side fouling service including: recuperators, regenerators, direct contact exchangers, heat pipe exchangers, and fluidized bed exchangers. Conventional recuperators such as firetube boilers, watertube boilers, shell-and-tube exchangers, gas-to-air exchangers, and finned-tube exchangers have been in existence for many years and only relatively minor design changes are possible in these units. Therefore, there is clearly a need for the development of innovative types of heat exchangers such as direct contact and fluidized bed exchangers as a means of overcoming the effects of gas-side fouling. Third, materials play a key role in the design of heat-transfer equipment for gas-side fouling and corrosion service. The most pressing materials problems occur in: (a) low-temperature heat recovery where acid condensation is a major problem, with plastic, glass, coatings, and alloy steel as potential solutions, and (b) high-temperature applications, where the development of superalloys and especially ceramic materials is essential.

SECTION 4

EXISTING GAS-SIDE FOULING FACTORS

There are very limited gas-side fouling data in the literature. In fact, most of the heat exchangers which are designed use "rule of thumb" gas-side fouling factors or resistances which are based on experience, rather than on actual data. The purpose of this section is to review the existing gas-side fouling data which are available, present values where appropriate, compare these fouling factors wherever possible, and summarize the present state-of-the-art in this area. In addition to information from the open literature, contributions from industrial contacts as listed in this section are also included.

4.1 FOULING FACTORS FOR FINNED TUBE BANKS COMPILED BY R.C. WEIERMAN

Representative fouling factors based on operating experience are presented by Weierman (Reference 4-1) as shown in Table 4-1. This information was compiled from four different sources as indicated at the bottom of Table 4-1. It should be noted that the gas-side fouling factors range from a minimum of $0.0005 \text{ hr-ft}^2\text{-F/Btu}$ for natural gas to a maximum of 0.05 for coal. Note also that Weierman has grouped the table into three categories: clean gas, average gas, and dirty gas. In the case of dirty gases it should be emphasized that although the heat exchanger is oversurfaced using the recommended fouling factors, this extra heat transfer surface area is added on the assumption that cleaning devices will be installed and used on the unit.

4.2 THE JOHN ZINK COMPANY RECOMMENDATIONS

Another similar set of values for fouling factors for finned tubes is presented in Table 4-2. These values were compiled by the John Zink Company (Zink) for a variety of gas-side fouling services. The fouling factors given in Table 4-2 are in substantial agreement with those presented by Weierman. The Zink fouling factors were taken from Reference 4-2.

Table 4-1. Design Parameters for Extended Surfaces in Fossil Fuel Exhaust Gases, Weierman (Reference 4-1)

Type of Flue Gas	Fouling Factor hr-ft ² -F/Btu	Surface Spacing in.	Gas Velocity ft/sec
Clean Gas (Cleaning devices not required)			
Natural Gas	.0005 - .003	.050 - .118	100 - 120
Propane	.001 - .003	.070	
Butane	.001 - .003	.070	
Gas Turbine	.001		
Average Gas (Provisions for future installation of cleaning device)			
No. 2 Oil	.002 - .004	.120 - .151	85 - 100
Gas Turbine	.0015		
Diesel Engine	.003		
Dirty Gas (Cleaning device required)			
No. 6 Oil	.003 - .007	.180 - .228	60 - 80
Crude Oil	.004 - .015	.200	
Residual Oil	.005 - .02	.200	
Coal	.005 - .05	.231 - .340	50 - 70

References: Boyen, J. L., Practical Heat Recovery, John Wiley, New York, 1975.

Csathy, D., "Heat Recovery from Dirty Gas," Presented at Sixth National Conference on Energy and the Environment," Pittsburgh, Pennsylvania, May 1979.

Watts, D., "Economy Begins to Favor Heat Recovery," ASHRAE Journal, Vol. 12, No. 2, 1970, pp. 54-62.

"Escoa Engineering Manual," Escoa Fintube Corporation, Pryor, Oklahoma, 1979.



Table 4-2. Recommended Fouling Factors ($\text{hr-ft}^2\text{-F/Btu}$) and Fin Pitch (fins per foot) for Various Flue Gases, The John Zink Company (Reference 4-2)

<u>Service</u>	<u>Maximum Recommended Fin Pitch fpf</u>	<u>Minimum Recommended Fouling Factor</u>	<u>Cleaning* Provisions Recommended</u>
Firing heavy residual oil, bunker "C"	24 to 30	.010	Yes
Firing with No. 5 & No. 6 oil	36	.005	Yes
Firing with No. 2 & No. 4 oil	48	.003	Yes
Firing only with natural gas	54 to 72	.001	No
Natural gas firing with No. 2 firing on standby less than 30 days/yr)	60	.002	No
Natural gas firing with No. 2 & No. 4 oil firing on interruptable basis	48	.002	Yes
Natural gas firing with heavy residium standby (emergency only)	36	.005	Yes
Natural gas firing with heavy residium for intermittent service	24 to 30	.010	Yes
Sodium bearing wastes	24	.03	Yes
Metallic oxides	24	.01	Yes
FCCU catalyst fines	24	.008	Yes

*Cleaning provisions include soot-blowing lanes and well boxes for mounting soot-blowing equipment.

4.3 TEMA FOULING FACTORS

A limited number of fouling factors for gases and vapors, as recommended by the Tubular Exchanger Manufacturers Association (TEMA) (Reference 4-3), are summarized in Table 4-3. For these gases and vapors, values of the fouling factor range from 0.001 to 0.01 $\text{hr-ft}^2\text{-Btu/hr}$, with only two combustion gases, manufactured gas and engine exhaust gas, listed. The TEMA fouling factors have been in use for many years and recently a committee has been formed under the leadership of James M. Chenoweth to re-evaluate these recommendations (Reference 4-4). This committee is made up of members from Heat Transfer Research, Inc. (HTRI) in Alhambra, California as well as from TEMA. Also, a very large advisory group has been organized for the purpose of reviewing the work of the committee. It is expected that the HTRI-TEMA committee will complete its work in about two years, but in all probability the emphasis will remain on fouling factors in liquid streams as is the case in the existing TEMA tables.



Table 4-3. TEMA Fouling Factors (Reference 4-3)

Type of Gases and Vapors	Fouling Factor, hr-ft ² -F/Btu
<u>Industrial</u>	
Manufactured Gas	0.01
Engine Exhaust Gas	0.01
Steam (non-oil bearing)	0.0005
Exhaust Steam (oil bearing)	0.001
Refrigerant Vapors (oil bearing)	0.002
Compressed Air	0.002
Industrial Organic Heat Transfer Media	0.001
<u>Chemical Processing</u>	
Acid Gas	0.001
Solvent Vapors	0.001
Stable Overhead Products	0.001
<u>Petroleum Processing</u>	
Atmospheric Tower Overhead Vapors	0.001
Light Naphthas	0.001
Vacuum Overhead Vapors	0.002
Natural Gas	0.001
Overhead Products	0.001
Coke Unit Overhead Vapors	0.002

4.4 EG&G IDAHO DIESEL EXHAUST FOULING FACTORS

Henslee and Bogue (Reference 4-5) have recently completed an experimental study on the gas-side fouling of a finned-tube heat exchanger in the exhaust of a stationary Diesel engine. Experiments were carried out using a No. 2 Diesel fuel with the following range of operating parameters: gas velocity 10 - 30



ft/sec, inlet gas temperature 350 - 580 F, and outlet gas temperature 220 - 430 F. Three series of tests were carried out for durations of 300, 320, and 430 hours for Runs 1, 2, and 3, respectively. This study was a follow-on to that conducted by AiResearch Manufacturing Company (Reference 3-13) using a No. 6 fuel oil. The transient fouling resistances, reaching a maximum value of about 0.14 hr-ft²-F/Btu, are shown in Fig. 4-1. It should be noted that after about 200 - 300 hours of operation, asymptotic fouling was achieved. Interestingly, Henslee and Bogue found that the asymptotic fouling thickness obtained in their study using No. 2 Diesel fuel was essentially the same as that found by AiResearch using No. 6 fuel oil, although the rate of fouling deposition was not the same. Finally, and most important, Henslee and Bogue have presented all of their fouling data in tabular form in their report. It is believed that this compilation represents the most complete set of gas-side fouling data available in the literature at the present time. Unfortunately, the set of tabular data is too extensive to be included in the present report.

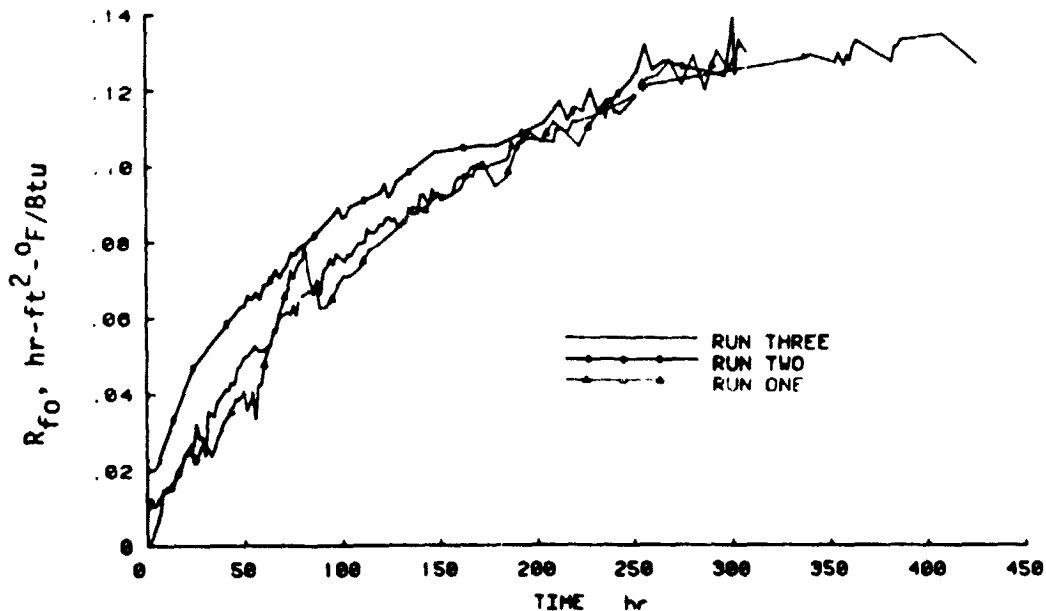

Figure 4-1. Experimental Diesel Exhaust Fouling Resistances, Henslee and Bogue (Reference 4-5)

4.5 DAVID W. TAYLOR R&D CENTER GAS TURBINE EXHAUST FOULING FACTORS

Rogalski (References 4-6, 4-7) has obtained experimental gas-side fouling resistances in gas-turbine exhaust streams. He used a specially designed 1-in. diameter cylindrical probe which was a heat pipe device. Test parameters were: gas velocity 43 - 290 ft/sec, gas temperature 522 - 922 F, and probe wall temperature 145 - 715 F. The TEMA tables, Table 4-3, indicate a fouling factor of 0.01 for engine exhaust gas streams (there is no specific entry for gas turbine exhaust). Compared to this TEMA value, Rogalski's results showed about the same fouling resistance for test times up to three hours, 1.5 times for a five-hour test, and four times the TEMA value for tests of 70-90 hours duration. Rogalski has presented his results in graphical form with selected values in tabular form as given in Table 4-4.

Table 4-4. Fouling Factors for Gas Turbine Exhaust, Rogalski (References 4-6, 4-7)

Test Time, hr	Fouling Factor, hr-ft ² -F/Btu
2.9	0.0103
3.1	0.0106
3.8	0.0028
5.1	0.0149
44.0	0.0133
144.0	0.0381

4.6 AIR-COOLER FOULING FACTOR USED BY AMOCO PRODUCTION COMPANY

The major product manufactured at the Amoco Production Company is natural gas. Steam condensers in their production facilities are primarily finned-tube air coolers. The air-side fouling factors used by Amoco personnel to design these units is 0.003 hr-ft²-F/Btu (Reference 4-8). This value, which is based on experience, takes into account corrosion of the finned air-side surfaces as well as any dirt which may accumulate on these surfaces.



4.7 ENTEC FIRED HEATER AND WASTE HEAT BOILER FOULING FACTOR

ENTEC (Reference 3-33) uses a design fouling factor of 0.005 to 0.008 hr-ft²-F/Btu for their fired heater and heat recovery units. This range of values remains essentially independent of specific combustion gas contaminants because ENTEC uses a sufficient number of sootblowers to maintain the fouling factor within this limited range during normal operating conditions. (See Section 6.4 for a further discussion of the ENTEC cleaning philosophy).

4.8 COMPARISON OF FOULING FACTORS FOR COMBUSTION GAS STREAMS

Since the vast majority of gas-side fouling problems arise from combustion gas streams, attention is focused on these gases in this section. A comparison of the fouling factors for the various combustion gas streams from the previously discussed sources is given in Table 4-5. Weierman's scheme of clean, average, and dirty gases (fuels) is used, along with a miscellaneous category for several additional combustion gas streams. It should be emphasized that certain very important process contaminated gas streams such as those in cement, aluminum, and pulp and paper industries do not appear in Table 4-5 because gas-side fouling factors for these streams are simply not available.

The Henslee-Bogue entries (Reference 4-5) represent the only known experimental asymptotic gas-side fouling factors available in the literature. The Rogalski data (References 4-6, 4-7) for gas turbine exhaust are also based on experimental data, but from Table 4-3 it is clear that asymptotic conditions were not achieved in his investigation. The remaining values in Table 4-4 all represent design values which are based on experience and which are probably somewhat below the expected asymptotic values. In some cases, as was clearly indicated in Table 4-1, the use of cleaning devices is required to maintain the specified fouling factors within a certain range during operation. Finally, it should be pointed out that the Weierman, Zink (Reference 4-2), and Henslee-Bogue entries in Table 4-5 are all for finned tubes while the Rogalski data were obtained using a probe consisting of a smooth, circular cylinder. The TEMA values are also probably for smooth surfaces, although no specific mention

Table 4-5. Comparison of Available Gas-Side Fouling Factors

GAS STREAM	R _f , Gas-Side Fouling Factor, hr-ft ² -F/Btu				
	Weierman (Ref. 4-1)	Zirk (Ref. 4-2)	TEMA (Ref. 4-3)	Rogalski (Ref. 4-6.7)	Henslee-Bogue (Ref. 4-5)
<u>Clean Gas</u>					
Natural Gas	0.0005 - 0.003	0.001	--	--	--
Propane	0.001 - 0.003	--	--	--	--
Butane	0.001 - 0.003	--	--	--	--
Gas Turbine	0.001	--	--	--	--
<u>Average Gas</u>					
No. 2 Oil	0.002 - 0.004	0.003	--	--	--
Gas Turbine	0.0015	--	--	0.003 - 0.038	--
Diesel Engine	0.003	--	0.010	--	0.120 - 0.140
<u>Dirty Gas</u>					
No. 6 Oil	0.003 - 0.007	0.005	--	--	--
Crude Oil	0.004 - 0.015	--	--	--	--
Residual Oil	0.005 - 0.02	0.010	--	--	--
Coal	0.005 - 0.05	--	--	--	--
<u>Miscellaneous</u>					
Sodium Bearing Waste	--	0.03	--	--	--
Metallic Oxides	--	0.01	--	--	--
FCCU Catalyst Finings	--	0.008	--	--	--



is made of this fact in the TEMA tables (Reference 4-3). The Zink fouling factors have an additional constraint in that they represent minimum recommended gas-side fouling factors for the service indicated.

It is apparent that there are a large number of vacancies in Table 4-5, thus making a comprehensive comparison of these fouling factors impossible. However, in those cases where duplicate entries exist, a comparison between the Weierman and Zink recommendations shows very good agreement. The discrepancy between the TEMA and Rogalski entries for gas turbine exhaust has previously been noted, and a substantial difference also exists between the Weierman and Rogalski gas turbine entries. However the greatest variation in the entire table occurs for Diesel engine exhaust where the Weierman, TEMA, and Henslee-Bogue values are 0.003, 0.010, and 0.12-0.14, respectively. This range represents fouling factors which, for the same exhaust gas, differ by nearly a factor of 50. Clearly, the matter of gas-side fouling factors for design purposes is badly in need of some additional attention.

4.9 SUMMARY

From the gas-side fouling factors presented and discussed in Section 4, the following conclusions are apparent:

- (a) There are very limited gas-side fouling factors available in the literature, and most of these are based on experience rather than on experimental data.
- (b) In those cases where gas-side fouling factors do exist, there are notable differences in some cases among the available data.
- (c) There are many applications -- for example, in the cement, aluminum, and pulp and paper industries -- where gas-side fouling factors simply do not exist.

These conclusions emphasize one of the high-priority recommendations made at the Gas-Side Fouling Workshop held in Boulder, Colorado in October 1981

(Reference 1-11). At that workshop the 41 participants, most of whom were from industry, recognized the important need for additional gas-side fouling factors for design purposes. Therefore, they recommended that experimental gas-side fouling factors should be obtained for typical industrial gas streams and for typical heat exchanger geometries. Unfortunately, the need to implement that recommendation is just as great today as it was when the Boulder workshop was held two years ago.



SECTION 5

STARTUP AND SHUTDOWN PROCEDURES TO MINIMIZE THE EFFECTS OF GAS-SIDE FOULING

Heat-transfer equipment for gas-side fouling service is generally designed for operation at some specified steady state operating conditions. However, during startup and shutdown conditions, as well as operation at off-design conditions, the exchanger operates at other than the conditions for which it was designed. The purpose of this section is to consider some of the techniques used to minimize the effects of gas-side fouling at these off-design conditions.

5.1 USE OF CLEAN FUEL DURING STARTUP CONDITIONS

One of the fairly standard startup conditions mentioned by several industrial contacts (Reference 5-1, 5-2) is the use of a clean fuel during startup conditions. For example, if a unit is designed for operation with residual oil, it would probably be started up using natural gas. Of course, combustion conditions during startup are a very important consideration, and a number of procedures have been developed to deal with the problem of deposition due to poor combustion. In particular, the procedures developed by Babcock and Wilcox (Reference 3-22) were highly recommended by Watts (Reference 5-1). Consequently, much of the following discussion is taken from Reference 3-22.

Placing a cold boiler (or other type of heat exchanger) in service requires firing at low heat input for a relatively long period of time in order to avoid expansion difficulties and the possible overheating of superheaters or reheaters. During this startup period the combustion efficiency is poor and -- especially with the heavier oils, coal and other dirty fuels -- considerable quantities of unburned material may escape. Therefore, the low ignition temperature of natural gas makes it an ideal fuel for startup.

Fuel oil and coal are potentially hazardous for starting operations. After about an hour of firing, low pressure boilers are ready to take the load and high pressure boilers, usually equipped with air preheaters, are beginning to supply preheated air to the burners which helps the combustion process. However, a careful inspection would reveal that both the air preheater and economizer surfaces have accumulated significant deposits of oil or oily soot. Furthermore, when such deposits are allowed to accumulate, they are rather easily ignited and a fire once started is difficult to extinguish. Theoclitus (Reference 5-3) has reported a number of problems in this area. To reduce the fire hazard potential, one solution is to use sootblowers which blow continuously on the surfaces of regenerative-type air preheaters as they rotate in the flue gases.

In those cases where oil must be used for startup, Babcock and Wilcox (Reference 3-22) recommends the following methods of firing in their order of preference:

- (a) By far the safest method producing the cleanest stack is to use steam atomizers and light fuel oil, No. 1 or No. 2, with steam or compressed air as the atomizing medium.
- (b) The second choice is to use steam atomization with fuel oil no heavier than No. 6, heated as required for proper atomization.
- (c) The third choice is to use steam atomizer nozzles with compressed air for atomization, and fuel no heavier than No. 6, heated as required.
- (d) Startup with oil using mechanical atomizers is not recommended because of the amount of oil and soot deposited in economizers and air preheaters, and the fire hazard, particularly in air preheaters. Stationary boilers, using mechanical atomizers for oil fired at loads between 20 and 100 percent of maximum and generally started up with gas or by Methods a, b, or c with oil.

5.2 MAINTAIN HEAT-EXCHANGER SURFACES ABOVE DEW-POINT TEMPERATURES

Severe gas-side fouling and corrosion problems can occur in heat exchangers under conditions when there are frequent shutdowns and startups. One possible way to avoid this problem is to maintain the heat exchanger surface temperature above the acid and water dewpoints by using hot air or some other warm fluid (References 5-4, 5-5). Of course, such a procedure is costly but considering the consequences it may well be worth the extra effort and cost in some applications. One added benefit, of course, is that when the unit is started up, a somewhat shorter startup period will be required because the unit is already partially heated.

The AiResearch Manufacturing Company has developed a series of plate fin heat exchangers as discussed in Section 3 for use in a variety of heat recovery applications. In one installation at a clay drying plant in California, considerable difficulties were encountered during startup because some of the condensables in the particulate-laden gases entering the unit were condensing on the cold heat exchanger surfaces. To overcome this problem, the exchanger was gradually heated up and brought on stream at essentially operating conditions and no further problems were encountered (Reference 3-17). This experience confirms the importance of not having cold surfaces in contact with gases which contain condensables during startup conditions.

5.3 USE OF BYPASS TO AVOID LOW FLOW VELOCITIES

As was discussed in Section 3, some fire-tube boilers are equipped with either an internal or external bypass to control the exit temperatures for certain processes such as producing sulfuric acid by burning sulfur. Although the bypass was installed for the purpose of controlling the exit gas temperature, it is also possible to use the bypass to control velocities in the exchanger during startup and shutdown conditions. Since the exchanger has been designed for a specific fouling factor for steady state operation, use of the unit under clean conditions requires a lower velocity. However, by judiciously making use of the temperature control bypass, it is also possible to minimize the use of low velocities under which fouling tendencies are greater because of the lower shear stresses in the fluid.

5.4 EXPERIENCE WITH AN ORGANIC RANKINE BOTTOMING CYCLE SYSTEM

The Sundstrand Corporation has developed an Organic Rankine Bottoming Cycle (ORBC) system which has been used in several industrial and utility applications. This system was designed to operate in exhaust gas streams with temperatures in the 600 to 1000 F range and uses toluene as the working fluid. The units tested to date include several installations in Diesel engine exhausts and one in a ceramics plant which utilized the exhaust gas from a ceramic drying kiln (References 5-6, 5-7, 5-8, 5-9). In particular, the operating experience at the Easton, Maryland public utility encountered a number of interesting startup and shutdown problems which will be described here.

At the Easton, Maryland facility the ORBC unit operated off the exhaust of two Diesel engines which used No. 2 Diesel fuel with a sulfur content of about 0.2 percent by weight. The sulfuric acid dewpoint temperature was calculated to be 249 F for this application. The engines were operated only when it was more cost effective to produce power than to purchase it from the electrical grid. Consequently, this unit typically operated only about eight hours per day. The heat-transfer system consisted of a boiler, a superheater, and a preheater. The major gas-side fouling and corrosion problems occurred in the preheater which was made of carbon steel with welded carbon steel fins having the following dimensions: fin density of five fins per inch, fin thickness of 0.050 in., and fin height of 0.75 in.

After about six months of intermittent operation, the cold end of the preheater was heavily fouled; however, the hottest part of this exchanger showed very little fouling. Consequently, the exhaust gas temperature under these conditions was about 450 F rather than the design value of 300 F. Also, the preheater pressure drop had increased significantly to a value of 6.78 in. H₂O compared to the design point of 3.89 in. as shown in Figure 5-1. The entire cleaning history of the preheater is shown in Figure 5-1. Initial attempts at cleaning the preheater included baking the unit (operating dry at 750 F) and the injection of low temperature soot release chemicals. The gas-side fouling deposits, which consisted primarily of soot, were removed reducing the bundle pressure drop to 5.8 in. H₂O; however, a considerable

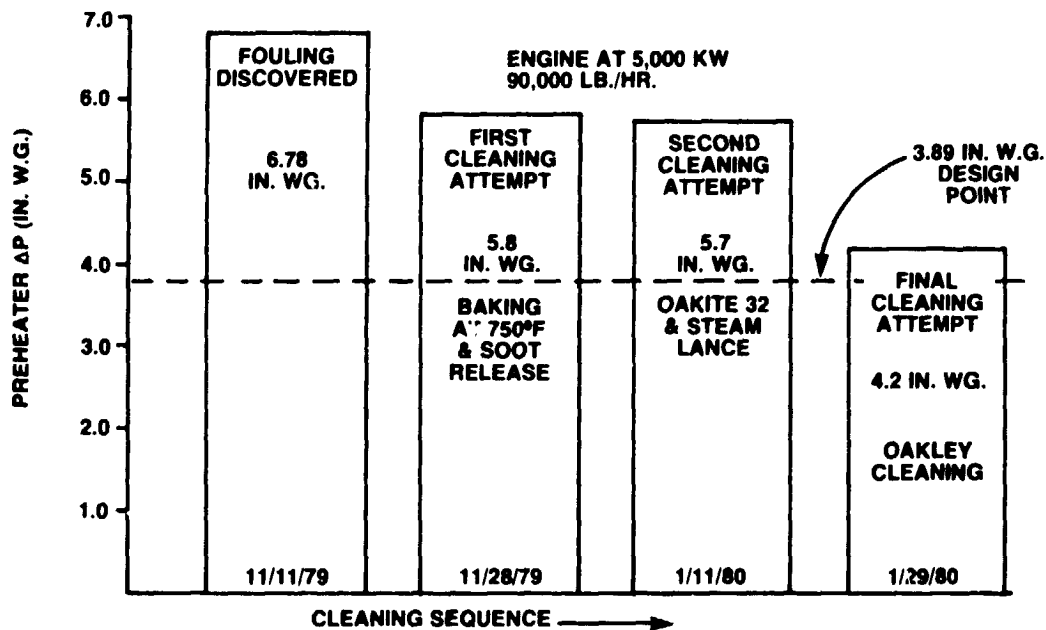

Figure 5-1. The Cleaning History in a Sundstrand ORBC Preheater (Reference 5-6)

buildup of corrosion products in the form of scale remained. A solution of Oakite 32 along with a steam lance was tried next and proved unsuccessful. Finally, Oakley Cleaning, a commercial cleaning firm, used a solution of Oakite 32, inhibited HCl, and water which was successful in almost totally cleaning the exchanger and reduced the preheater pressure drop to just about 4 in. H₂O as shown in Figure 5-1. During subsequent operations it was established that periodic baking and the use of low temperature soot release chemicals were adequate to maintain the preheater in a sufficiently clean operating condition.



Two major factors were identified as contributing to the gas-side fouling and corrosion deposits. First, the daily startup and shutdowns were a major problem. Each startup was from a cold condition with the metal surface temperature below the sulfuric acid dewpoint temperature so that large amounts of acid were condensed during this time. Approximately 20 minutes were spent below the acid dewpoint temperature during a typical startup. The acid severely attacked the fins in the cold end of the preheater. Also, the stack through which the exhaust gases were discharged was uncapped and uninsulated; consequently, acid condensed on the inside of the stack, ran down the surface, and attacked the last row of preheater tubes. Second, the diverter valve was replaced with two valves in series along with a fan which provided a positive pressure between them. Thus, any leakage into the engine exhaust came from the ambient air rather than from the engine. Third, the ORBC control settings were adjusted in order to shorten the startup time. Fourth, every attempt was made to minimize the number of required startup and shutdown operations. All of these actions were successful to some extent in reducing the gas-side fouling and corrosion problems in this particular application.

5.5 SHUTDOWN OPERATIONS

Boiler units must generally be taken out of service at regular intervals for internal inspection, cleaning, and repair. If the heat-transfer surfaces are to be cleaned externally, the operation should be carried out as completely as possible before the fire has died out and should be finished by means of air lances and scrapers after the unit has cooled off (Reference 3-22). If the deposits are not removed before the boiler shutdown, they will act as a sponge to collect acid and water condensate and subject the surface to corrosion.

An interesting shutdown procedure has been reported by Hung (Reference 5-10). He carried out some tests using a small firetube boiler to determine the feasibility of using a waste heat boiler on an existing incinerator system. The exhaust gases in this particular application, which burned a variety of pumpable and non-pumpable wastes, included HCl as well as other potentially corrosive constituents. The tests were carried out on an intermittent basis; for example, an 8-hr operation during the day followed by a

shutdown at night was a fairly standard procedure. The standard shutdown practice always included opening an inlet access door prior to turning off the fan, thus drawing in ambient air and purging the boiler of the HCl gas inside the tubes before the metal surface temperature dropped below the acid dewpoint temperature. Thus, the possibility of acid condensation forming on the tube surfaces was minimized, and the tests showed that carbon steel tubes could be used in this application, provided that this precaution and some additional operating procedures were observed. Hung's experimental procedure was based on some operations which he had observed at some full-scale incinerator installations.

5.6 SUMMARY

In some cases startup and shutdown operations can cause severe gas-side fouling and corrosion problems because the units are not operating under the conditions for which they were designed. A few of the procedures which have been used to overcome such problems have been discussed in this section. However, it is apparent that such procedures are somewhat limited and that some of them are very site dependent. In particular, the installation and initial operation of new systems such as the Sundstrand Organic Rankine Bottoming Cycle system are especially vulnerable to fouling and corrosion startup and shutdown problems. Unfortunately, in many such cases satisfactory operating procedures must be developed on a trial-and-error basis. It is clear that the development of additional startup and shutdown procedures would be most welcome by individuals dealing with gas-side fouling and corrosion problems.

SECTION 6

GAS-SIDE FOULING PREVENTION, MITIGATION, AND ACCOMMODATION TECHNIQUES

A number of prevention, mitigation, and accommodation techniques are used by industry in an attempt to deal with gas-side fouling. These techniques may be grouped under the general categories of: fuel cleaning techniques, control of combustion conditions, fuel and gas additives, surface cleaning techniques, quenching, control of operating conditions, and gas cleaning techniques. Each of these categories is considered in this section with the major emphasis on additives, surface cleaning techniques, and the control of operating conditions.

6.1 FUEL CLEANING TECHNIQUES

Ash and other constituents such as sodium, sulfur, and vanadium are entirely, or at least partially, responsible for the deposits which form on heat-transfer surfaces through the various gas-side fouling transport processes. Therefore, the removal of any of these constituents prior to the combustion process is highly desirable.

According to Reference 3-22, processes are available for both the desulfurization and de-ashing of residual fuel oils. Water washing of residual fuel oils has been successful in some marine applications, but this procedure will probably not be widely used because only sodium and sediment are removed by this process. The practice of water washing out of service, and to some extent in service, has helped to overcome some of the problems experienced with present fuel oils.

Essenhigh (Reference 6-1) has pointed out that commercial and experimental methods, including gravity separation and froth flotation, are available for the mechanical and physical cleaning of coal. However, mechanical/physical methods of cleaning remove only the mineral matter, and

thus only the inorganic sulfur, from the coal. Also, such cleaning methods are not very successful in removing very fine, micron sized mineral particles. Chemical methods for cleaning coal are still in the conceptual or experimental stage.

6.2 CONTROL OF COMBUSTION CONDITIONS

A very important consideration in the prevention of gas-side fouling and corrosion is the control of combustion conditions to minimize the formation of particulate matter in exhaust gases [Thompson, (Reference 3-27)]. The type of fuel burned, the type of combustion equipment, and the burner design are all important considerations in the formation of particulates, including soot, in combustion gases. For example, a good distribution of water droplets in a liquid fuel can produce much better combustion and much less soot than would otherwise be the case. In many cases, the ash effects of various fuels on the downstream combustion gases is not known very well. Thompson also pointed out that other important parameters in the combustion process are fuel injection pattern, fuel injection schedule, and fuel viscosity control. Of course, the use of air preheaters to improve combustion efficiency is a very common practice. One final problem which he pointed out deals with the great variability of fuel supplies in some cases, and the difficulties which arise as a consequence. For example, the quality of the coal supplied to industrial users is much more variable than that for electric utilities. Also, in those operations which burn either agricultural or miscellaneous wastes, the variability of these fuels can be a major factor in downstream fouling problems. A final consideration is the classical problem of gas-side fouling and corrosion caused by H_2SO_4 condensation at low temperatures. One solution to this problem is to control the amount of excess air, which in turn governs the conversion of SO_2 to SO_3 , and hence the amount of H_2SO_4 formation. Although this discussion has been brief, it is quite clear that the upstream combustion conditions play a critical role in the subsequent downstream gas-side fouling and corrosion problems.

An example which confirms the validity of the discussion in the preceding paragraph deals with the effects of premixing air and fuel prior to

the combustion process. White (Reference 6-2) investigated the effects of premixing the fuel (JP-5) and oxidizer on the gas-side fouling downstream of a gas turbine. He found that fuel-air premixing virtually eliminated the production of soot and that it was virtually impossible to foul the downstream heat exchanger under these operating conditions. White's observations are shown qualitatively in Figure 6-1.

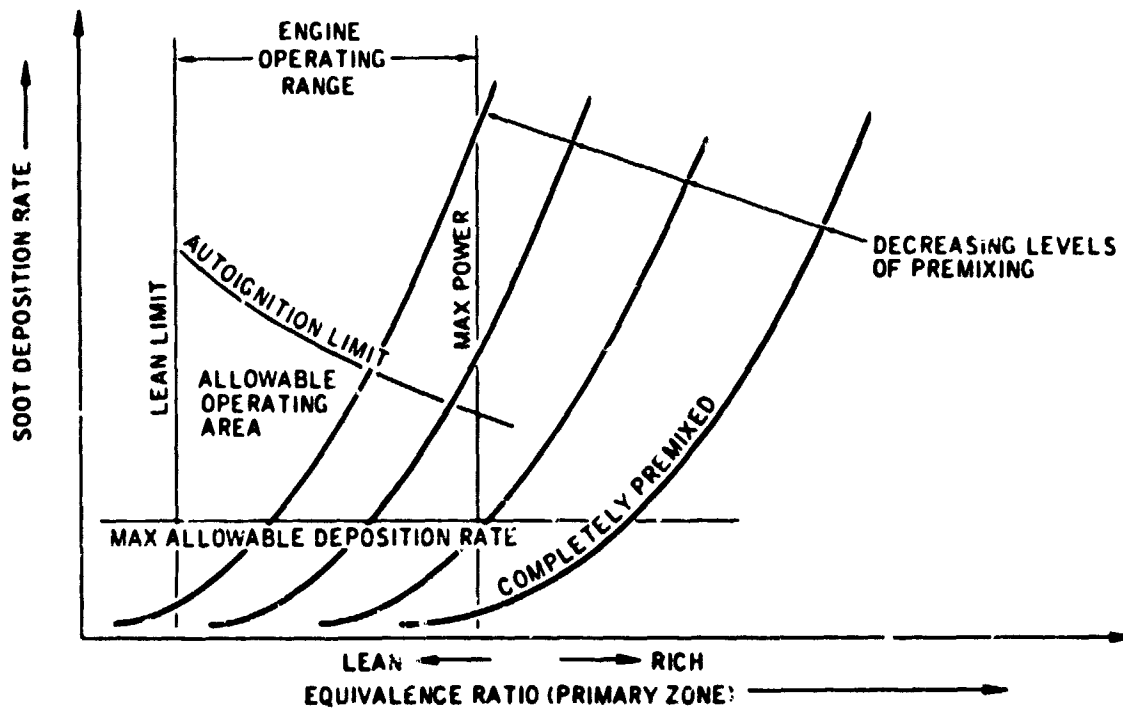

Figure 6-1. Probable Soot Deposition Rates with Combustion System Parameters (Reference 6-2)

6.3 FUEL AND GAS ADDITIVES

Under some conditons chemical additives can improve combustion efficiency, reduce emissions, and mitigate the effects of gas-side fouling and corrosion. Many proprietary additives have been marketed, with the performance of some much more successful than others. As Radway has pointed out (Reference 6-3), a certain amount of skepticism does exist regarding the use of additives:

A generation of "snake oil" peddlers offering magic formulations to cure all problems has resulted in a skepticism toward additives. Unfortunately, those companies who try to approach the problem in an open and scientific fashion are often classified automatically as unscrupulous before they get an opportunity to present the facts.

In this section the use of additives for oil- and coal-fired systems is first considered separately. A successful case history of an oil-fired boiler is presented next, followed by a brief consideration of why magnesium-based additives are successful in mitigating gas-side fouling and corrosion problems.

6.3.1 Oil-Fired Systems

Libutti (Reference 6-4) has presented some interesting results for cold-end additives using No. 6 oil containing 0.9 - 2.5 percent sulfur. The tests were carried out in three utility and two industrial boilers, with the powdered additives injected between the boiler economizer and air preheater. Additives tested included calcium hydroxide, magnesium oxide, sodium aluminate, sodium carbonate, ammonium bicarbonate, activated alumina, expanded vermiculite, and silica. Tests were carried out for surface temperatures between 180 and 360 F. Libutti concluded that:

- o Fine particle size is essential in cold-end additives

- o High absorptivity and at least moderate alkalinity are desirable in cold-end additives
- o Aluminum oxide, ammonium bicarbonate, magnesium oxide, and silica are suitable materials for powdered cold-end additive constituents

Battelle Columbus Laboratories (BCL), under the sponsorship of the Electric Power Research Institute, has recently been involved in two activities which report the state-of-the-art in the important area of additives for coal and oil firing. Although this work was directed primarily toward the utility industry, the results are also applicable under similar conditions wherever they occur in industry. The first activity in 1980 (Reference 1-9), a literature review of additives, was followed by a workshop on the same topic later that year (Reference 1-10).

First, in the case of residual oils, there are three chemical elements which cause fouling problems which can be alleviated with additives: sulfur, vanadium, and sodium. Interestingly, although some sodium occurs naturally in crude oil, most of that found in residual oils results from contamination by seawater during ocean transport. Refineries use a desalting procedure which removes all but about 10 - 30 ppm of sodium in the oil. During the combustion of residual oils, most of the sulfur burns to become SO_2 . About one percent of the SO_2 is converted to SO_3 , which in turn combines with water vapor in the combustion gases to form H_2SO_4 . This conversion of SO_2 to SO_3 can continue through the boiler as a result of catalytic action by iron and vanadium compounds. Meanwhile, the vanadium in the residual oil is oxidized to V_2O_5 , which may then react with the sodium and other trace metals in the fuel to form metal vanadates. Table 6-1, which was taken from Reference 1-10, indicates the additives which have been effective for SO_3 -related problems. Note that both low-temperature corrosion and low-temperature fouling are included in Table 6-1. The various additives which have been used to attack this problem include MgO , $\text{Mg}(\text{OH})_2$, Mg metal, Mg-Mn, and dolomite. Shown in Table 6-2 are additives which have been effective for vanadium and sodium related problems for high-temperature fouling and corrosion. Again, these have been primarily Mg-based and Mn additives.

Table 6-1. Additive Trials Rated as Effective for SO₃-Related Problems (Reference 1-10)

Additive Generic Class	Primary Purpose for Additive Use			
	SO ₃ and Acid Smuts	Low Temperature Corrosion	Low Temperature Fouling	Plume Visibility
<u>Mg-Based Additives</u>				
MgO/dry powder	L	L	--	--
MgO/oil dispersion	H	H	--	--
MgO + Al ₂ O ₃ /oil dispersion	VH	VH	M	--
MgO + Mn oxide/oil dispersion	M	L	--	--
MgO + Mg(OH) ₂ /dry powder	L	M	M	L
Mg(OH) ₂ /dry powder	--	L	--	--
Mg metal	L	L	--	--
Oil-soluble Mg	--	L	--	--
Oil-soluble Mg-Mn	L	L	--	L
Dolomite	--	L	--	--
<u>Mn & Other Metals as Additives</u>				
Mn oxides/oil dispersion	L	L	L	L
Oil-soluble Mn	--	--	--	L
Oil-soluble Fe	--	--	--	L
Oil-soluble metal combinations	L	--	--	--
<u>Other Additives</u>				
NH ₃ -forming solutions	--	--	--	L
NH ₃	--	L	--	--
Petroleum coke/pulverized	L	--	--	--

Number of Trials: L = 1-9; M = 10-19; H = 20-29; VH = 30+.

Table 6-2. Additive Trials Rated as Effective for Vanadium and Sodium-Related Problems (Reference 1-10)

Additive Generic Class	Primary Purpose for Additive Use		
	High Temperature Corrosion	High Temperature Fouling	Ash Modification
<u>Mg-Based Additives</u>			
MgO/dry powder	L	--	--
MgO/oil dispersion	VH	L	--
MgO + Al ₂ O ₃ /oil dispersion	VH	M	L
MgO + Mn oxide/oil dispersion	M	M	--
Mg(OH) ₂ /dry powder	L	--	--
Mg metal	L	--	--
Oil-soluble Mg	L	--	L
Oil-soluble Mg-Mn	--	--	L
Dolomite	L	--	--
<u>Mn & Other Metals as Additives</u>			
Mn oxides/oil dispersion	M	M	--
Mn oxides + alumina/oil dispersion	L	L	--
Oil-soluble metal combinations	L	L	--
Number of Trials: L = 1-9; M = 10-19; H = 20-29; VH = 30+.			

The conclusions reached by the workshop participants regarding the use of additives in combatting residual oil fouling and corrosion problems are taken directly from Reference 1-10:

- o MgO in an oil dispersion is the additive most effective in combatting corrosion from vanadium and sulfur trioxide.
- o Many other additives are useful, depending on circumstances.
- o Additive performance is site specific; experience in one boiler is not directly transferable to another.
- o There are many unanswered questions regarding additive use, including the most effective test-program procedures.

More recently Krause et al. (Reference 6-5) have carried out some experimental studies of the effect of additives on residual fuel oils. They tested a number of magnesium and manganese-based additives and reached the following conclusions in their study:

- o For reduction of SO₃ in the flue gases, low excess air was as effective as using MgO and MnO additives with high excess air.
- o The combined effect of operating at low excess air and using additives greatly reduced SO₃ and minimized the deposits.
- o Deposit adherence in a fuel with a low Na/V ratio was substantially reduced by the use of magnesium or manganese additives.
- o High-temperature corrosion was reduced most effectively by fine particle (2 microns or less) MgO additives, although manganese oxide also provided some corrosion reduction.
- o Aluminum or silicon used with MgO did not reduce deposit adherence that occurred with a high-sodium, high-vanadium fuel, and had no beneficial results on corrosion rates of the alloys that were exposed.

6.3.2 Coal-Fired Systems

The results of the Battelle survey and workshop clearly showed that much less work has been done in the area of additives in coal-fired systems than for residual oils. As may be seen in Table 6-3, MgO/Oil, MgO + Mn/Dry, CaCO₃, and boron-based additives have been used in an attempt to combat high-temperature fouling and ash modification. Only in the case of boron-based additives has there been significant experience, and even then only in the modification of ash. Regarding coal additives, the workshop participants drew the following rather general conclusions (Reference 1-10):

- o The use of additives developed for oil firing has been helpful in some cases, but is neither optimum nor sufficient for all cases.
- o Better data are needed on a range of problems and applications, including slag behavior, deposit effects, corrosion suppression, plume-visibility reduction, and coal handling.

Table 6-3. Additives Effective in Coal-Fired Boilers (Reference 1-10)

	High Temperature Fouling	Ash Modification	Superheat Control
MgO / Oil			Limited Experience
MgO + Mn Dry	Limited Experience		
CaCO ₃		One Case	
Boron Based		Significant Experience	Limited Experience

Radway (Reference 6-3) acknowledges that the mechanisms by which very small quantities of dispersed magnesium successfully prevent or remove boiler deposits is not completely understood. This observation is echoed by Thompson (Reference 3-27) who feels that there is a great need for very carefully controlled experiments with additives in order to obtain a better understanding of the basic phenomena involved. Such data would provide information on why some additives work successfully and others do not.

6.3.3 Oil-Fired Additives: A brief Case History

Cold-end gas-side fouling and corrosion results from SO_3 in the flue gas condensing as H_2SO_4 on the cooler ends of air preheaters and other heat exchangers. The South Carolina Electric and Gas Company (SCE&G) was having some cold-end corrosion problems in two Ljungstrom air preheaters on an oil-fired utility boiler (Reference 6-5). Three solutions were considered:

- (a) Raise the exit gas temperature.
- (b) Reduce the SO_3 concentration.
- (c) Reduce the O_2 level to reduce the production of SO_3 from SO_2 .

Of these three possibilities, SCE&G decided that the only practical solution was to lower the SO_3 concentration. Again, there were three possible ways to achieve this objective:

- (a) Lower the oxygen content of the combustion air.
- (b) Change to a fuel with a lower sulfur content.
- (c) Use chemical additives to neutralize gaseous SO_3 .

The fuel was a No. 6 oil which contained 2.1 - 2.2 percent sulfur, 0.082 percent ash, and 360 ppm of vanadium. The high concentration of vanadium, which acts as a catalyst for the conversion of SO_2 to SO_3 , was definitely a problem in this particular application.

Based on some technical analysis, as well as economic considerations, SCE&G decided to use a chemical treatment and chose the Coaltrol M Flue Gas Neutralizing System in an attempt to reduce the gas-side fouling and corrosion

problems. The Coaltrol M, a proprietary powder, was injected in the gas duct upstream of the air preheaters. Shortly after the chemical treatment started, a visual inspection showed an improvement in the preheater condition with a reduction in the amount of plugging. Measurements showed that the SO₃ content was reduced by 93 percent, from 30.7 ppm to 2.2 ppm, and the acid dewpoint temperature from 289 F to 252 F. Thus, in addition to reducing the gas-side fouling and corrosion problems, it was possible to operate the regenerators at a lower exit gas temperature providing an annual energy savings of about \$100,000. The one-time capital cost of the feed system to inject the additives was \$80,000.

6.3.4 The Mitigating Effects of Magnesium-Based Additives

As was seen in the previous case history, additives in some cases can reduce the concentration of SO₃ in combustion gases. In such cases, the acid dewpoint temperature is reduced as is the amount of H₂SO₄ condensed on cool surfaces. Alkaline earths such as magnesium can also have beneficial effects in combustion gases containing sodium.

The deposition of sodium sulfate, which is formed by the reaction



is a widely occurring phenomenon in the cement, glass, pulp and paper, and most other industries. The Na₂SO₄ deposits can also react with the SO₃ in the gas stream



to form sodium-iron trisulfate which is a tenacious, corrosive type of deposit.

On the other hand, magnesium oxide can also react with SO₃



to form magnesium sulfate with deposits which are softer and more friable than Na₂SO₄ and hence may be removed from the surface more easily. It should be

pointed out that MgO tends to be more reactive with SO₃ than Na; therefore, the reaction in Eq. 6-3 is more likely to occur than that in Eq. 6-1. In addition, the magnesium sulfate can react with sodium sulfate

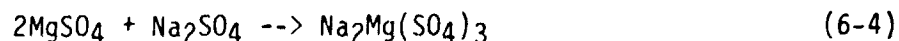

to produce sodium-magnesium trisulfate, Na₂Mg(SO₄)₃, which again is softer and more friable than the sodium-iron trisulfate discussed earlier.

Although this brief discussion has presented some basis for the success of Mg-based additives, it should be emphasized that many questions relating to the effectiveness of additives remain unanswered. Although most of the efforts to date have concentrated on MgO additives, additional investigations may lead to the development of other additives.

6.4 SURFACE CLEANING TECHNIQUES

A number of surface cleaning techniques have been developed and used by industry including steam and air sootblowing, sonic sootblowing, and water washing. Other approaches which are used to some extent include: chemical, mechanical, and thermal cleaning. Each of these methods is discussed in this section.

6.4.1 Steam and Air Sootblowers

The most widely used technique to clean gas-side fouled heat-transfer surfaces is sootblowing using steam or air. Sootblower design and operation parameters are outlined in Table 6-4 (Reference 3-22). The blowing medium is generally air or dry steam, with both pressure and temperature of the blowing medium important parameters. The location and spacing of the sootblowers within the heat exchanger are very important. The important parameters associated with the sootblower nozzles are the number, type, size, and angle of attack. Finally, the speed and frequency of the sootblower operation depends on at least the type of fuel, the amount of excess air, and the operating conditions.

Table 6-4. Sootblower Design and Operation (Reference 3-22)

1. Blowing Medium
 - a. Air or steam
 - b. Pressure
 - c. Temperature
 2. Type of Sootblower
 - a. Short Retractable
 - b. Long Retractable
 - c. Fixed Position Rotating
 - d. Traveling Frame
 3. Location and Spacing of Sootblower
 4. Sootblower Nozzles
 - a. Type
 - b. Size
 - c. Number
 - d. Angle of attack
 5. Lance-Tube Speed
 - a. Rotational
 - b. Axial
 6. Frequency of Blower Operation
-

Rotary and Retractable Sootblowers

DiCarlo (Reference 6-7) has recently presented a discussion of the two major types of sootblowers which are the rotary and long retractable types as shown in Figure 6-2. The rotary sootblower utilizes a multi-nozzled element permanently located in the tubebank to be cleaned. The nozzles are positioned along the element to locate one nozzle in each tube lane. The long retractable sootblower can be operated either manually or automatically. The blowing pressure can be regulated at the head from 100 - 350 psig. Rotary blowers are limited to flue gas temperatures below 1000 F because the unit is exposed to the flue gases at all times. However, the long retractable type can be used at virtually any gas temperature.

Sootblower Specification as a Function of Ash Content

ENTEC designs, fabricates, and installs fired heaters and waste heat boilers. Gas-side fouling is not a serious problem for ENTEC because of their approach (Reference 3-33). Basically, the type of steam sootblower specified is a function of the ash content in the fuel as indicated in Table 6-5.

Table 6-5. ENTEC Sootblower Specification as a Function of Ash Content (Reference 3-33)

Ash Content, Percent	Type of Sootblower
< 0.08	No Problem
0.08 to 0.12	Stationary
0.12 to 0.2	Rotary
> 0.2	Traversing

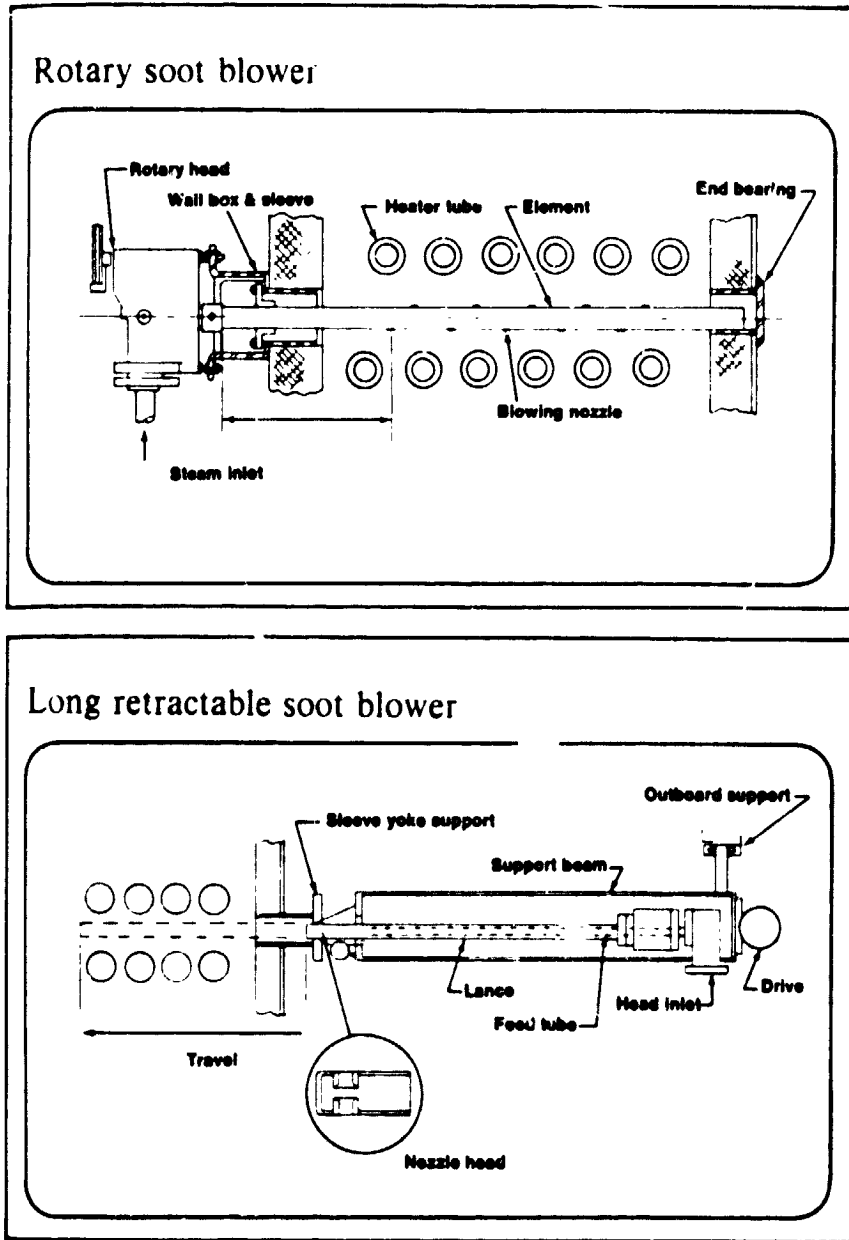

Figure 6-2. The Rotary and Long Retractable Sootblowers (Reference 6-7)

Thus, by specifying the number and type of sootblowers, the gas-side fouling factor is maintained between 0.005 and 0.008 hr-ft²-F/Btu during operating conditions. At this level of fouling, the controlling factor is the gas-side heat transfer coefficient, not the gas-side fouling resistance. Of greater concern is the tubeside fouling resistance which is magnified through the large outside-to-inside area ratio as a consequence of the external fins.

Frequency of Sootblowing

The frequency of sootblowing is an important consideration because of the costs involved. In past years a single blow during each of the three shifts on a 24-hr operation was considered standard practice in many boiler operations. Although a precise knowledge of optimum cleaning cycles has not been established, more sophisticated methods are being employed in some installations today. For example, in the St. Regis Paper Plant, which uses black liquor as a fuel in their recovery boilers, the steam sootblowers are actuated when the bundle pressure drop reaches a predetermined value (Reference 6-8). Since gas-side fouling deposits impede heat transfer, an increase in the outlet gas temperature may also be used effectively as a parameter for this purpose as reported by Young (Reference 6-8).

A computer-control system was recently installed at the Rauma-Repola Oy Pulp Mill in Finland which burns a spent sulfite liquor (Reference 6-10). Sootblowers are required to remove gas-side deposits which include Na₂CO₃, Na₂SO₄, Na₂S₂O₇, and NaHSO₄, some of which tend to be corrosive. Gas-side temperatures, heat transfer coefficients, and pressure drops -- along with feedwater temperatures -- are used as sensing parameters for cleaning. The sootblowers in the recovery boilers are divided into six different groups, with each group individually controlled. When one of the parameters relating to a specific group exceeds a predetermined value, the computer-system automatically actuates that group of sootblowers. Thus, sootblowing is used only when and where needed. Through the use of the automatically controlled cleaning system, the steam consumption due to sootblowing has decreased from 4.8 to 3.0 percent of the total plant steam generation. At the same time, the boiler has been maintained in cleaner condition than before.

6.4.2 Sonic Sootblowers

Although both low-frequency and high-frequency sound has been used in an attempt to clean fouled heat-transfer surfaces, most of the attention has been focused on low-frequency horns.

KVB, Inc., Irvine, California, started marketing Swedish-manufactured sonic sootblowers, or sonic horns, about 6 or 7 years ago (References 6-11, 6-12, 6-13). Presently there are about 600 of these horns in operation in the U.S. and 1000 worldwide. They are being used in many different applications including: precipitators, recovery boiler hoppers, direct-fired boilers, heat recovery boilers, CO boilers, air preheaters, and process heaters. Forty-five of these installations are on heat-transfer equipment of some type in this country which utilize combustion gases from oil, wastes, bark, black liquor, coal, residual oil, NH_4S sulfite, wood, red liquor, and refuse. Installations during the current year include: a waste heat boiler using miscellaneous wastes as fuel, an economizer on a recovery boiler which uses black liquor in the pulp and paper industry, an electric utility which burns coal, and a waste heat boiler in an acid decomposition process in a refinery.

The KVB Acousticlean Sonic Sootblower shown in Figure 6-3, operates at a frequency of 220 Hz and makes a sound very similar to a ship's horn. The horn has a length of 24 in. and a maximum diameter of 12 in. with a weight of 65 lb. The operating air pressure is 60 to 80 psi with an operating air consumption of 40 - 80 SCFM per horn, depending on the application. Typical materials are stainless steel for the horn and titanium or stainless steel for the diaphragm which is the only moving part in the horn. The use of these materials allows the horn to be used in gaseous environments up to 1900 F. A minimum sound pressure level of 130 decibels (db) is required for effective cleaning.

Soot and other particles attached to the surface are dislodged by sound wave vibration energy generated by the horns. The wave-pressure fluidizes particles by breaking their bonds with other particles and the surface to which they are attached. Once fluidized, the particles will flow from the surface under gravitational or gas stream pressure forces.

ORIGINAL COPY
OF THE...

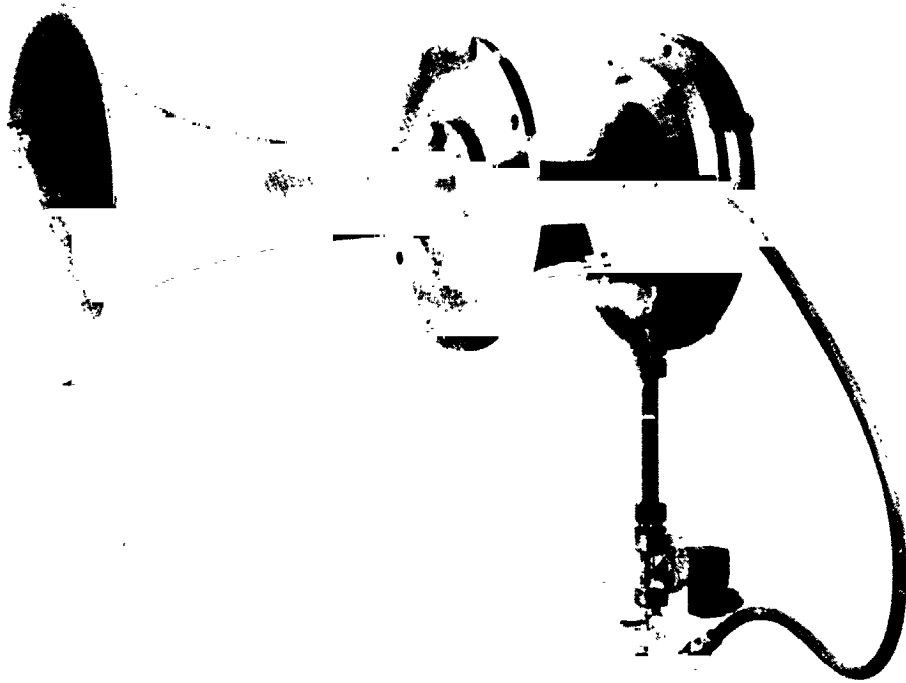

Figure 6-3. The KVB Acousticlean Sonic Sootblower
(Reference 6-11)

The effectiveness of the horns is generally determined by monitoring the outlet temperature of the heat exchanger which, in turn, is used to establish the cleaning cycle.

The Diamond Power Specialty Company, Lancaster, Ohio is manufacturing and marketing a low frequency, sonic sootblower under a joint agreement with Mats Olson Konsult AB of Sweden. This sootblower, designated as the Diamond Power Infrasonic Hz-20, operates at 20 Hz, which is inaudible to the human ear, in the 130 - 135 db range. A schematic drawing of this horn is shown in Figure 6-4 (Reference 6-14).

This horn is just over 15 ft long and weighs 650 lb, with both the resonance tube and diaphragm made of carbon steel. The system operates with a 75 psig minimum air supply and requires a volumetric flowrate of 200 - 700 SCFM, depending on the specific application.

Typical heat-exchanger applications have included boilers, economizers, and air preheaters. In one case, a Diamond Power horn was installed on a large finned tube economizer, about 20 ft by 6.5 ft by 40 ft high, on a recovery boiler. Prior to the installation of the horn, a shot system had to be run continuously to clean the economizer. The sonic sootblower, operating six minutes every half hour or 20 percent of the time, was sufficient to maintain the unit in operating condition. In addition to keeping the unit clean, it was estimated that the installation annually saved \$34,000 in maintenance, capital, and operating costs. In another application, an Infrasonic Hz-20 was installed on a boiler with a capacity of 110 tons of steam per hour. The unit had plain tubes throughout and was fired with No. 5 and 6 fuel oil. The boiler was equipped with six steam sootblowers which were operated four times per day: two retractable types between the secondary and primary superheaters, two retractable types between the primary superheater and the first bank of the economizer, and two rotary types between the first and second tubebanks in the economizer. The sonic sootblower was installed between the secondary and primary superheaters. None of the steam sootblowers have had to operate since the horn was installed.

ORIGINAL PAGE IS
OF POOR QUALITY

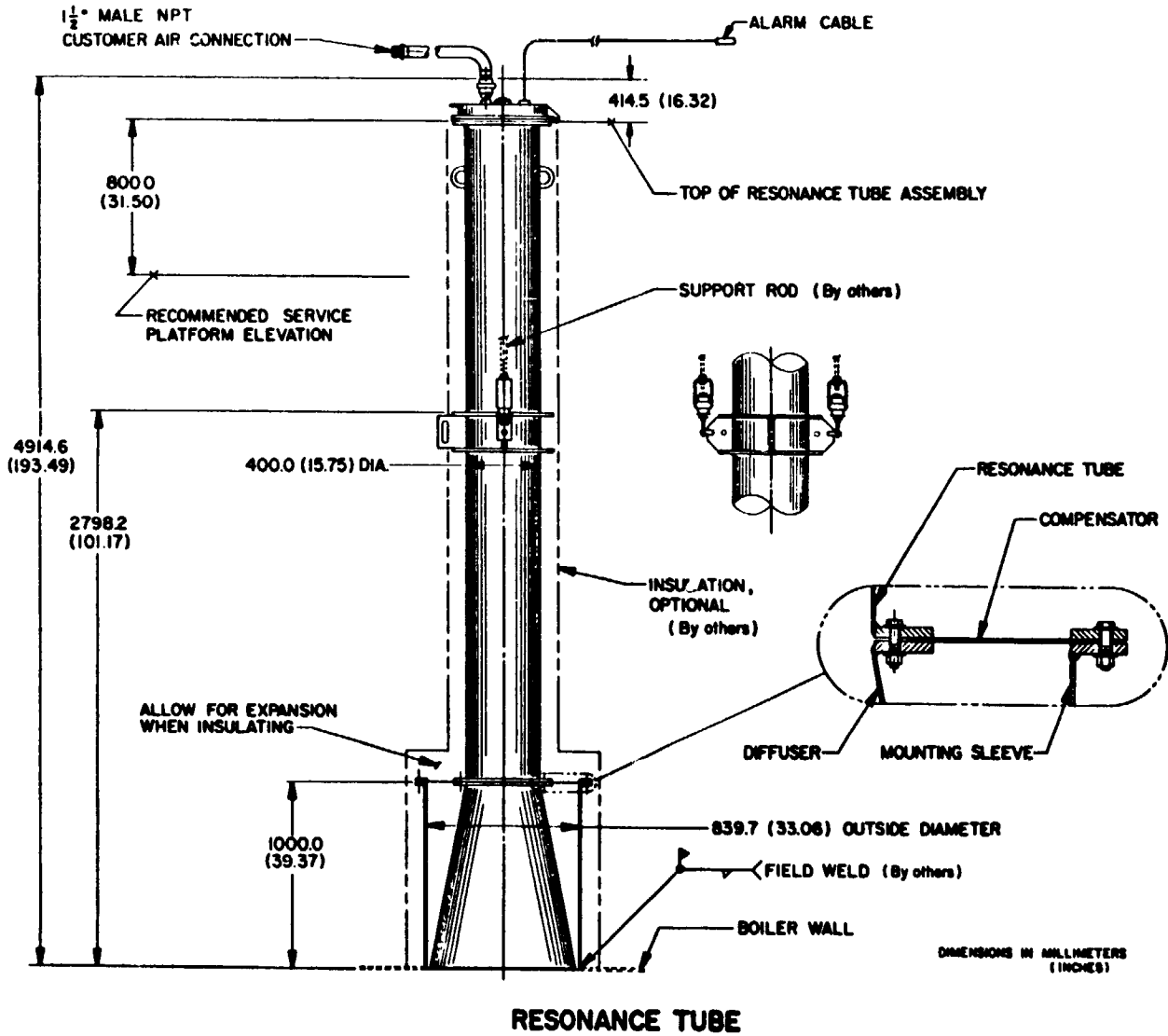

Figure 6-4. The Diamond Power Infrasonic Hz-20 Sonic Sootblower
(Reference 6-14)

Some general observations on the use of sonic sootblowers or horns are in order. Sonic horns work best for light, fluffy deposits. Horns become increasingly less effective as the deposits move from light, fluffy ones toward sticky, tenacious deposits. The cleaning cycle for horns is significantly different for steam sootblowers and sonic horns. Steam sootblowers typically are operated once per shift whereas horns are blown on a more-or-less continuous basis. Capital costs for horns are greater than for steam sootblowers, but the operating costs are significantly lower (Reference 6-11). Finally, it is interesting to note that most horns have been installed on a retrofit basis, i.e., the exchanger was not designed for use with a sonic sootblower. This fact indicates that horns generally are being installed only when plants are having serious gas-side fouling problems. In other words, horns are used more-or-less as a last resort. Although there have been cases where sticky-type deposits have prevented successful operation of horns, there are many applications where horns are presently operating successfully.

6.4.3 Water Washing

Water washing is widely used to clean air preheaters as well as other types of heat-transfer equipment. Water soluble deposit accumulations formed on heat-transfer surfaces may be easily removed by washing, provided that a sufficient quantity of water is used. The standard water washing apparatus is a stationary, high-penetration, multi-nozzle device. The high velocity jets produce a high fluid shear stress along with contractions caused by thermal shock to accomplish the removal of the deposits. Most of the following discussion on water washing is taken from Reference 6-15.

Water washing devices are normally located at both the hot and cold ends of the exchanger, in the case of an air preheater, and are generally operated simultaneously in order to effectively remove the deposits. The number and orifice diameter of the nozzles vary with the size of the heat exchanger.

Fresh water is ordinarily used for washing. In the case of saltwater wash, it is highly desirable to rinse the unit with fresh water at the

conclusion of the washing operation. The most commonly used sources of water for this purpose are rivers, lakes, and ponds. Well water and house-service water are also used extensively. The water source must be free of any debris which would plug the passages in the heat exchanger or clog nozzles and pumps.

The frequency of water washing depends on a number of factors including: quality of the fuel burned, nature and amount of deposit, operating conditions, dryness of soot blowing medium (if any), etc. The actual washing operations may be carried out under the following conditions:

- (a) out-of-service.
- (b) in-service isolated.
- (c) in-service on-stream.

Each of these conditions will be discussed briefly.

Out-of-service water washing is carried out when the unit is shut down for regularly scheduled inspection, maintenance, or repair work. Out-of-service washing affords the best possible opportunity for close control of the washing operation and for a thorough inspection of the heating surface before, during, and after the washing procedure. Care should be taken to ensure that all deposits are completely washed from the surface. Experience has shown that such residue deposits can become baked on the heat-transfer surface and are extremely difficult to remove.

In-service isolated water washing consists of washing one exchanger in a two-or-more exchanger installation. The procedure consists of reducing boiler load and isolating one exchanger by closing dampers and shutting down associated fans while the boiler remains on line. The other unit continues in operation.

Finally, the third method is in-service on-stream washing or on-stream washing. On-stream washing is carried out while allowing both the gas and other fluid to pass through the heat exchanger. On-stream washing is applicable only in those installations where the ductwork and location of

drains are such as to eliminate or at least minimize the amount of moisture entering the dust collectors, precipitators, wind boxes, and boilers.

In some cases insoluble material is carried from the boiler by the gas stream and large particles are wedged in the flow passages at the hot end of the heat exchanger. In such cases this type of deposit is difficult to remove using standard washing equipment. Therefore, special washing equipment utilizing high-energy jets has been developed for this purpose. These devices use intermediate-pressure (400 - 1000 psig), high-volume (600 - 1200 gal/min) washing.

6.4.4 Other Cleaning Techniques

Other cleaning techniques may be grouped into the categories of chemical, mechanical, and thermal cleaning. Chemical cleaning is generally used as an off-line technique for gas-side fouling deposits. Thermal cleaning, which is also called self-cleaning or baking at elevated temperatures, consists of heating the exchanger and holding it at an elevated temperature until the deposits are baked off. Shah (Reference 3-19) has reported on the use of this technique to clean plate-fin exchangers used in the paint and pulp and paper industries. In those particular applications, the units were designed in modular form which allowed the fouled modules to be removed, replaced by clean ones, and then cleaned off-line using thermal cleaning. Mechanical cleaning is more applicable to gas-side fouling deposits and includes the use of shot, surface vibration, mechanical brushing, and scouring with nutshells. Several examples are reported in this section.

The use of metal brushes and nutshells was discussed briefly in Section 3 in connection with a fluidized bed exchanger and a heat recovery system using FCCU exhaust gases, respectively. Shot cleaning utilizes small metal or ceramic shot which are dropped over the top of the heat exchanger. Thus, cleaning of the surface by mechanical action is accomplished as the shot moves down through the exchanger under the influence of gravity. The shot is then collected at the bottom of the heat exchanger, conveyed back to the top of the unit, and the entire process repeated as necessary. In some applications this technique is used on a continual basis (Reference 6-14).

A mechanical cleaning method, such as shaking or vibrating a tube bundle, is sometimes used (Reference 3-1) in the primary metals industry where ores and pyrites of copper or zinc are roasted in a fluidized bed to decompose the ore and transfer it to a material suitable for reduction. During this roasting process a dusty gas containing SO_2 is formed which is used to produce H_2SO_4 . The gases are cooled from about 1800 to 750 F before going to a gas cleanup section. Owing to the very dusty nature of the gases, the design of the boiler in this case must be modified somewhat. One option is to use a vertical platen type heat exchanger with the gases flowing on the outside of the tubebank. Since dust and metal particles stick to the tubes, frequent cleaning of the surfaces is necessary. However, in this particular application steam sootblowing is undesirable since it affects the gas composition and increases the moisture content. Thus, a mechanical cleaning method, such as shaking or vibrating the tube bundle, works very effectively in such cases.

Conseco (Reference 6-16) has developed a water-tube heat-recovery boiler which is cleaned using vibration techniques. This exchanger features a vibratory vertical grid heat-transfer surface and is designed to handle particle loadings up to 30 grains/ft³. It is available with either plain or finned tubes and is designed with a modular feature which allows for individual tube replacement without disturbing the remaining tubes. This exchanger, which can be constructed from a variety of corrosion-resistant materials, has been used in the off gas from an incinerator burning sewage cake treated with ferric chloride.

6.4.5 Cleaning Techniques for Plate-Fin Heat Exchangers

AiResearch has carried out an extensive test program dealing with the cleaning of their plate-fin heat exchangers (Reference 3-17). These tests were carried out specifically to determine the feasibility of using plate-fin units in the exhaust gases from a glass-melting furnace as part of a Brayton cycle heat recovery system. The objectives of this study were to: (a) evaluate the gas-side fouling characteristics of several AiResearch plate-fin configurations, (b) develop methods to effectively clean these exchangers, and

(c) determine the fouling associated with the presence of several constituents in the gas stream. Two cleaning techniques were developed for use in this study:

- (a) An air lance with movable high-pressure air jets, with the cleaning air blowing in the same direction as the hot gases.
- (b) An air cannon using a sudden blow-off by a large volume of high pressure (150 psig) air, with the cleaning air blowing from the opposite direction to the hot gas stream.

In the first set of tests (Reference 6-17), dust from operating glass furnaces was collected and injected into natural gas combustion products, along with appropriate gaseous species, to produce simulated exhaust gases. These gases entered the test unit at a temperature of about 1250 F with gas velocities ranging from 19 to 31 ft/sec. Five different plate-fin modules with 3 - 7.5 fins/in., including both plain and offset fins, were tested and both the hot-end and cold-end fouling characteristics were observed. The hot-end results showed that the dust deposits on the core surfaces were light and fluffy and were easily blown away. The gas-side fouling rate of the offset-fin was about 8 to 10 times higher than the plain-fin design. Thus, while the air lance was able to effectively clean the plain-fin cores during operation, it was not able to clean the offset fins. Also, the air cannon, in addition to requiring a temporary shutdown for implementation, was not very effective in cleaning the offset fins either. It became quite apparent that the use of the offset-fin cores could not be used in applications where gas-side fouling was a potential problem. At the cold end of the unit, condensation of H_2SO_4 and water caused severe corroding of Type 409 stainless steel, and the material was ruled out for this particular application. Also, the combined condensate-flue dust deposit could not be removed with either the air cannon or the air lance. For this type of deposit, it was found necessary to take the unit off-line and use either steam or water injection to clean the surface.

The second series of tests (Reference 6-18) was carried out with an inlet gas temperature of 1450 F and face velocity of 24 ft/sec. Based on the

earlier studies, a Type 409 stainless steel core with 7.5 plain fins per inches was investigated. For these tests the cold-end temperatures were maintained above the acid and water dewpoint temperatures in contrast to the earlier study. The sodium sulfate in the dust combined with the SO_3 in the gas stream to form sodium pyrosulfate according to the reaction



In this series of tests sodium pyrosulfate, $Na_2S_2O_7$, tended to deposit on the cold-end surfaces.

Just as in the earlier tests, the hot-end deposits were light and fluffy and easily removed with the air lance. However, at the cold end of the exchanger the $Na_2S_2O_7$ deposited on the cold surfaces and acted as a "glue" to attract additional particulates from the gas stream. The air lance was not effective in cleaning the surface when the $Na_2S_2O_7$ concentration was greater than about 10 percent in the deposits. However for smaller amounts of sodium pyrosulfate it was possible to clean the cold end of the exchanger using the air lance. The pH of the deposits was used to monitor the percentage of the $Na_2S_2O_7$ in the deposits and hence the cleanability of the surface. For example, if the deposit pH was greater than about three, it was possible to clean the cold-end surfaces using the air lance. By maintaining the coldest corner of the crossflow exchanger above a minimum value, about 400 F for the tests which were carried out, an air lance could be used to prevent heat exchanger fouling from the gas stream. Finally, in carrying out associated corrosion studies with several different alloys, it was found that Type 310 stainless steel gave the best performance in this particular application.

As an alternative to increasing the cold end metal temperature to avoid the $Na_2S_2O_7$ deposition problem, it was suggested that MgO be added to the gas stream to neutralize the SO_3 in the gas stream, and hence reduce the amount of $Na_2S_2O_7$ formed according to Eq. 6-5. The results of this study emphasize the importance of knowing the constituents in the deposits and the reactions which produce these constituents, and then matching the type of

cleaning with the type of deposit. Also, the knowledge that certain types of surfaces, in this case the offset-fin geometry, tend to foul more easily than others is very valuable design information.

6.5 QUENCHING

The purpose of quenching a hot flue gas is to reduce the temperature in order to solidify molten and soft particles in the gas thereby preventing attachment of the particles at the cooler heat transfer surface. There are essentially four different fluids used to quench gases (Reference 5-1):

- (a) Cool Flue Gases
- (b) Steam
- (c) Air
- (d) Water Spray.

Of these four techniques, cool flue gas quench is probably the most desirable and water spray quench the least desirable. The following case history from the cement industry illustrates the effectiveness of this technique if carried out properly (Reference 3-9).

Cementos Mexicanos planned the addition of a four-stage preheater kiln at their Torreon Plant. An analysis of the raw materials indicated that up to a 7.5 percent alkali by-pass would be required to prevent buildups in the preheater. The alkali by-pass was designed to remove 7.5 percent of the kiln exit gases containing alkali-chloride vapors before these vapors condense on the colder preheater feed and create buildups in the preheater. The extracted kiln gases at 1920 F are immediately quenched with air at 77 F to a mix gas temperature of about 710 F to rapidly solidify the alkali salts. Since the decision was made to clean the gases in a glass bag dust collector, secondary cooling would be required to cool the gases to 530 F before entering the dust collector.

Two alternate solutions to secondary cooling of the gases were compared. Alternate A was to add 7300 SCFM of dilution air at 77 F to cool the

13,400 SCFM of mix gas from 710 to 480 F, resulting in the dust collector and ID fan being sized for 20,700 SCFM at 480 F. Alternate B was to cool the 13,400 SCFM of mix gas indirectly in a gas cooling heat exchanger, resulting in a 35 percent reduction in the size of the dust collector, ID fan, and motor. The cost savings in the dust collector, ID fan, and motor were considerably greater than the cost of the heat exchanger, making Alternate B lower in both capital and operating costs. While the economic justification favored Alternate B, there still was concern that the alkali salts would condense on the cool heat exchanger walls. A thorough evaluation by Cementos Mexicanos indicated that the rapid quenching of the kiln exit gases from 1920 F to 710 F would transform the alkali salts from the liquid state to the solid state before entering the heat exchanger tubes, thereby avoiding buildups on the tube walls. Cementos Mexicanos decided to install a Smith Gas Cooling Heat Exchanger designed to cool 13,400 SCFM from 710 to 480 F with a 0.6 in. water pressure drop.

The unit went into operation in September 1980. The heat exchanger has one 20-hp fan which runs constantly with the thermocouple at the dust collector inlet controlling the dilution air damper to maintain the 480 F set point. Periodic inspection of the heat exchanger indicates that the inside walls of the tubes are clean. They have never had to clean the tubes or to perform any maintenance on the unit.

6.6 CONTROL OF OPERATING CONDITIONS

The importance of properly controlled operating conditions cannot be overemphasized as a technique for mitigating the effects of gas-side fouling. Probably the classical technique is to maintain surface temperatures above the acid dewpoint temperature at the cold end of low-temperature heat recovery systems. Listed below are brief descriptions of what two industrial firms are doing to combat gas-side fouling problems and two examples illustrating the importance of controlled operating conditions.

Monsanto Chemical Operations

The Monsanto Chemical Intermediates Company Chocolate Bayou Plant in Alvin, Texas (Reference 3-32) produces a number of intermediate chemicals. The major product is acrylonitrile, with a variety of others including a poultry food supplement. Furnaces are used in three areas: steam generation, process applications, and waste incineration. The waste incinerators use a variety of feedstocks. The only one to cause problems is one using phenol process bottoms containing sodium sulfate salts. The waste-heat boiler in this system has experienced some gas-side fouling problems from the deposition of Na_2SO_4 . Control is achieved by steam soot blowers applied once per shift. Problems develop, it has been determined, if the blowing is not consistently applied on this basis. With proper application they can operate from four to six months between shutdowns for cleaning, which is indicated by a predetermined increase in stack temperature. The input concentration of Na_2SO_4 is about one percent as required to meet stack particulate emission requirements. A softball-size chunk of deposit was displayed which showed obvious evidence of an amorphous Na_2SO_4 formed from the liquid state. However, no corrosion has been observed in this application.

Bethlehem Steel Heat Recovery

Bethlehem Steel is using compact recuperators on their box annealing furnaces (Reference 6-19). The recuperators are brazed plate-fin (stainless steel) made by Garrett AiResearch Manufacturing Company. The program was sponsored in part by DOE. The exchangers are rated at 1500 F. The furnace gas is coke oven off-gas with 50 grains/100 SCF of gas particulate matter and is used to preheat air to 1200 - 1300 F. Flue gas temperature at the recuperator exit is 180 - 230 F. They are operating in the acid dewpoint range.

The unit began to corrode and plug. Because of the counterflow nature of the flow, the cold zone has moved further into the unit. After six months the unit was about one-third plugged by deposits. At the hot end, stannites were formed. Analyses showed the composition of these deposits to be iron, chromium, and nickel. The iron was from the furnace, while the chromium and

nickel were from braze alloys and the heat exchanger. The deposits at the cold-end of the exchanger contained iron, chromium, nickel, and sulfur.

The units operate on a cycle of two to three days, with a down time of about one-half day. One unit/burner has been installed. All hot surfaces are clean. There was concern about dewpoint corrosion prior to installation. Therefore, coupons were tested with braze material prior to installation, but no corrosion problems were observed. The units have been operating for about one year now. Battelle Columbus is carrying out some analysis of the data.

It is estimated that fuel savings of about 23 percent are being obtained through the use of these units. Baseline fuel consumption was 0.925 MM Btu/ton, with 0.716 MM Btu/ton using the present recuperator. However, in order to eliminate the acid dewpoint problems, it is estimated that a two to three percent loss in fuel savings will be observed. As a rule-of-thumb estimate, a 50 F drop in air temperature means about a one percent loss in fuel savings. Bethlehem Steel feels that more and more by-product gases, such as coke oven gas will be used in the future in the steel industry.

Diesel Exhaust Fouling

AiResearch (Reference 3-13) has carried out an extensive study of gas-side fouling downstream of a Diesel engine using No. 6 Diesel fuel. A finned-tube module was placed in the exhaust of an engine to study the effects of gas-side fouling and corrosion under actual operating conditions. The use of such tests, under carefully controlled conditions, can yield very valuable information on the potential fouling and corrosion in full-scale industrial heat exchangers. The major findings as reported by DeAnda (Reference 3-13) are:

- (a) Operating the heat exchanger module below the acid dewpoint temperature in the exhaust stream of No. 6 Diesel fuel did not produce corrosion, even though H_2SO_4 was present.

- (b) In the 150 - 550 F temperature range, two types of fouling mechanisms were observed: (i) acid condensation, and (ii) hydrocarbon condensation. Initially, a thin layer of acid condenses on the surface followed by the attachment of soot particles to the wet surface which absorb the H_2SO_4 . As the temperature of the fouling layer increases because of the increasing fouling resistance, the surface temperature exposed to the exhaust gases also increases. Thus, the surface temperature increases above the acid dewpoint temperature preventing further acid condensation. Buildups from that time on are due to unburned hydrocarbons.
- (c) Tests were run on uncooled surfaces, but no deposition was observed under these conditions.
- (d) Fin type does not affect the gas-side fouling rate. Plain- and segmented-finned tubes having identical fin densities and fin heights exhibited the same fouling characteristics.
- (e) As the number of fins per unit length increased, the fouling increased.
- (f) The pressure drop increased rapidly during the first 48 hours of operation, corresponding to a rapid deterioration of the heat transfer performance during the same period of time.

Switch Condenser

One very interesting application in the chemical industry (Reference 3-39) occurs where the deposition of constituents from a gas stream is actually desirable, and this process requires carefully controlled operating conditions. Phthalic anhydride is a very important intermediate used in making a number of dyes such as eosin, rhodamines, erythrosin, quinoline yellow, copper phthalocyanine, and phenolphthalein and as a step in the manufacture of anthraquinone and anthraquinone derivatives.

The manufacturing process for phthalic anhydride starts with the controlled oxidation of ortho-xylene or naphthalene using V_2O_5 as a catalyst in a tubular reactor. The products of combustion pass over a bundle of finned tubes with chilled water flowing inside the tubes, thus depositing the phthalic anhydride, which has a sublimation temperature of 130.8 F, onto the surface of the exchanger. As the deposition of phthalic anhydride continues, a critical pressure drop across the finned tube bundle is exceeded and, by means of a sensor, the tubeside fluid is switched from water to a heating medium with temperature somewhat greater than the melting point temperature of the phthalic anhydride, hence the name switch condenser. The phthalic anhydride thus melts, runs off the finned tubes, and is collected in a receiving vessel. When essentially all of the material has melted off the surface, the tubeside fluid is switched back to water and the process is repeated.

6.7 GAS-CLEANING TECHNIQUES

Particulate removal from gases may be carried out using electrostatic precipitators, mechanical collectors, fabric filters, and wet scrubbers. Gaseous pollutants are more difficult to remove than particulates using standard methods such as limestone addition, wet scrubbing without sulfur recovery, MgO systems with sulfur recovery, and dry sorbent systems (Reference 3-22). In most applications the particulates and gaseous pollutants are removed for environmental reasons which, unfortunately, generally occurs downstream of the heat exchanger. However, three techniques which are applicable to heat-transfer equipment are considered here.

Amoco Production Company's primary product is natural gas. Gas-side fouling in their furnace and heat recovery units is virtually non-existent due to the very clean fuel. The gas passes through molecular sieves to remove entrained droplets of organic liquids, undergoes water wash and other sweetening processes to remove sulfur, and finally passes through alumina beds for drying. Observed deposits appear to be sand induced through combustion air into the furnace (Reference 4-8).

Harwell Laboratory in the United Kingdom has been investigating the feasibility of using ceramic fabric filters to remove particulates from heavy-fuel Diesel exhausts. The filters are made of woven ceramic fibers consisting of 95 percent Al_2O_3 and five percent SiO_2 . In these tests, the exhaust gases entered the outer position of an annulus, passed through the filter, and then exhausted through the center tube. In the filtration system there were several bags in parallel to facilitate cleaning. It was found that a light cake on the filter surface, created when 0.3 microns particles plugged the filter, was required to achieve effective filtration. A reverse air pulse, actuated once each hour, was effective in throwing off the accumulated particles and thus cleaning the filters. During these tests it was found that the minimum and maximum pressure drop through the filtration system were 1.18 and 9.45 in. H_2O , respectively. The maximum pressure drop through the filters is a very severe constraint since very little back pressure may be imposed on the engine. For average size particles of 0.5 microns, the collection efficiency ranged from 82 - 95 percent for this system. The results from these tests indicate that this technique is effective but that it is prohibitively expensive. However, if exhaust gases must be cleaned for environmental purposes, it appears that this technique would work satisfactorily and reduce the particulate fouling potential as a bonus (Reference 6-20).

Hung (Reference 5-10) carried out some laboratory tests exploring the possibility of using a firetube boiler in the exhaust gases from a waste incinerator. As a result of this study, Hung concluded that a cyclone ahead of a waste heat boiler operating in flue gases with heavy particulate loadings would be a definite advantage. A cyclone would not only prevent any large, heavy particles from going through the boiler, but would also provide additional retention time for complete oxidation of these flue gases in case of a sudden temperature surge in the incinerator. Such an upset could occur, for example, with a change in the composition of the waste being burned. More complete oxidation would also minimize the deposition of unburned soot on the boiler tube surfaces.

In summary, Sotter (Reference 3-35) has pointed out that in a boiler dirty, particulate-laden combustion gases typically come into contact with solid surfaces with three distinct functions

- (a) Heat-transfer surfaces, for direct-fired heating or heat recovery.
- (b) Scrubbers and other devices, to remove undesirable gaseous components such as SO_2 .
- (c) Devices such as electrostatic precipitators, to remove particulates.

Sotter emphasized the considerable economic incentives and operational advantages for combining these functions into a single operation to make the overall process more efficient and less expensive. Clearly, this area is one in need of some innovative ideas.

6.8 SUMMARY

A number of gas-side fouling prevention, mitigation, and accommodation techniques have been discussed in this section. Fuel and gas cleaning techniques have had limited success in mitigating gas-side fouling. The control of combustion conditions -- although a difficult task, especially with variable fuel supplies -- influences the amount of particulates and other impurities in the exhaust gas streams and is a very important consideration. Fuel and gas additives have received a lot of attention with MgO being the most widely used chemical. There needs to be more work in the area of additives, especially for coal and fuels other than oil. In addition, some carefully controlled experiments are required to obtain a better understanding of why some additives work and other do not and also to develop new additives. The topic of surface cleaning is probably the most important one in this section since this is one of the most effective ways for industry to combat the problem of gas-side fouling. The techniques of steam and air sootblowing are well established and widely used. Recent interest in optimum cleaning cycles, including computer control, should make this type of cleaning less costly and more efficient. Sonic

sootblowers or horns have received increasing use during the last five years in this country as non-intrusive, type of cleaning, generally on a retrofit basis. Sonic horns are very effective when the deposits are soft and friable, but do not work well when the deposits are wet and sticky. Additional work is needed to determine more precisely the successful operating boundaries for these devices. Water washing is another cleaning technique which is widely used and fairly standard washing procedures have been developed. Mechanical cleaning methods such as the use of shot and scouring with nutshells are also effective in many cases. Quenching, or the rapid cooling, of hot gases is used in some cases to solidify particulates which would otherwise deposit onto cooled heat-transfer surfaces. Finally, the control of operating conditions, including parameters such as gas and surface temperature, is a very important consideration in trying to minimize deposits from dirty gases.

SECTION 7

ECONOMIC IMPACT OF GAS-SIDE FOULING

Estimating the economic impact of gas-side fouling on industrial operations is a most difficult task. Although certain aspects of gas-side fouling are generic in nature, specific gas-side fouling problems tend to vary somewhat from industry to industry because of the use of different fuels, processes, operating conditions, and other related parameters. In addition, a great deal of uncertainty is involved in trying to quantify the various factors which contribute to the overall costs of gas-side fouling, even within a specific industry. Therefore, it is not surprising that the relatively few economic analyses which have been carried out to date have a great deal of uncertainty associated with them. However, the basic factors which contribute to the cost of gas-side fouling have been well established.

The deleterious effects of gas-side fouling in industry may be broken down into the following categories:

- (a) Increased capital costs
- (b) Increased maintenance costs
- (c) Loss of production
- (d) Energy losses.

Each of these items will be considered in more detail, followed by several quantitative analyses on the costs of gas-side fouling. These analyses are taken from existing publications and from personal contacts made during the course of this study.

7.1 THE DELETERIOUS EFFECTS OF GAS-SIDE FOULING

Increased capital costs result in part from oversizing equipment to account for the anticipated fouling. First, the fouling layer produces a

thermal resistance because of its relatively low thermal conductivity. This resistance, in turn, requires a larger surface area for a given heat transfer requirement. Gas-side fouling factors are not well known at the present time, so excessively large safety factors can result in very conservative designs. Second, because of reduced flow passages due to the fouling layer, an increased pressure drop is produced. Therefore, capital expenditures are required for larger fans because of the larger power requirements. In some cases, capital cost increases due to increased pressure drop can be as large or larger than those due to oversurfacing because of reduced heat transfer. Third, in those situations where on-stream cleaning of the heat transfer surfaces is required, there are capital costs associated with the provision for cleaning equipment.

The next item to be considered is that of increased maintenance costs. The major factors here are the cost of cleaning and the cost of additives. In waste heat boilers, sootblowers are generally used for cleaning purposes using either steam or air. Sonic devices show some promise for the future, especially for light, fluffy deposits. Water washing is another important cleaning technique. These techniques and additional methods are discussed in Section 6. If at all possible, cleaning is done onstream. However, in the event the system must be shut down because of gas-side fouling problems, there will be maintenance costs associated with the manual cleaning of the heat transfer surfaces. For example, such procedures are used routinely in the maintenance of suspension preheaters used in the cement industry. Additional maintenance costs will also be incurred when trouble shooting gas-side fouling problems and in carrying out the associated chemical and related analyses. There is considerable interest in the use of additives to mitigate gas-side fouling but these can be quite expensive. For example, in 1979 MgO additives in the form of oil soluble products cost from \$4.00 to \$8.00 per pound (Radway, et al. Reference 7-1).

The loss of production can be a very significant factor depending on the nature of the specific problem. Downtime or operation at reduced capacity due to gas-side fouling can result from deposits in any of the various heat exchangers described in Section 3. In addition to the loss of finished product during the actual downtime, some time will usually be required for transient

cooling on shutdown and heating on startup. Although loss of production in general is a very difficult item to quantify, it is clearly a very important factor.

The final item to be considered here is energy losses due to gas-side fouling. The obvious items are energy losses due to reduced heat transfer and increased power requirements because of larger pressure drops. However, in addition to these factors, a more serious consideration is that of dumping dirty gas streams because of the potential for gas-side fouling in heat recovery systems, along with the associated problems of maintenance and loss of production. For example, in the glass industry essentially no heat recovery is presently being used downstream of the brick checkers regenerators for that reason (Reference 1-14). Flue gases at 1000 - 1200 F are just being exhausted into the atmosphere. However, given that a hot exhaust stream is available, if there is no pressing need for the recuperated energy it will not be utilized, irrespective of potential gas-side fouling problems. In addition to the glass industry there is a considerable amount of energy which is also being exhausted from U.S. cement plants (Reference 1-13).

7.2 THACKERY'S ANALYSIS OF THE COST OF FOULING IN THE UNITED KINGDOM

There have been very few attempts to quantify the deleterious effects of any type of fouling. The major problem is the number of uncertainties involved in such an analysis. As Thackery (Reference 7-2) has pointed out, such efforts are basically a series of "considered guesses" because of the many unknowns. However, Reference 7-2 is undoubtedly the best and most comprehensive contribution in this area. Thackery's analysis includes the cost of all types of fouling in the United Kingdom and attaches an estimated cost in British pounds to each of the associated costs. His final estimate for the costs of fouling in the United Kingdom was somewhere in the range of 370-490 million pounds sterling (1978 values). A breakdown of Thackery's costs is given in Table 7-1. It should be pointed out that these estimated costs include those associated with both gas-side and liquid-side fouling.

Table 7-1. Estimated Annual Costs of Fouling in the United Kingdom
(Reference 7-2)

Type of Cost	Estimated Cost (1978)
Capital Costs	£ 100 million
Maintenance Costs	70 - 90 million
Loss of Production	100 million
Energy Losses	<u>100 - 200 million</u>
Total £ 370 - 490 million	

7.3 WEIERMAN'S ANALYSIS OF GAS-SIDE FOULING COSTS ON EQUIPMENT

This analysis, made by R. C. Weierman of Escoa Fintube Corporation, was taken from Reference 7-3. Fossil fuels are used to supply over 60 quadrillion Btu annually in the United States. Of this total, nearly 30 percent is consumed directly in industrial heating applications. Fossil fuels supply over 80 percent of the energy used in industrial processes and this dependence is likely to continue for decades. However, energy costs are not always a substantial fraction of the production costs for the energy intensive industries. As a result, industrial energy efficiency is often as low as 10 percent and seldom exceeds 30 percent. Because of this, significant energy savings are considered possible with the application of existing, emerging, and advanced technologies. While better equipment maintenance and operation, along with minor modifications to existing equipment, can result in some energy savings, major process changes and capital expenditures are needed to achieve very large savings. For the near term, the most attractive prospect for energy efficiency improvement is recovery or utilization of some of the 12 quadrillion Btu presently being exhausted to the environment. At an average value of about \$2 per million Btu, this waste energy represents a total value of more than \$24 billion in fuel costs. It is estimated that 10-20 percent of this energy can be economically recovered in the near term if some existing technical problems can be overcome.

One of the major technical problems is that of gas-side fouling of the heat exchangers involved in the recovery and utilization of this energy. Consideration of the unusually high fouling potential of fossil fuel flue gas streams and associated cleaning difficulties generally results in higher equipment costs, maintenance costs, and production costs. The two basic approaches to gas-side fouling are to: (a) modify the process involved to reduce the fouling, and (b) design the equipment to perform under the expected fouling conditions. Although process modifications are considered the most sophisticated approach, their development and implementation are generally of a long term nature. Modification of existing equipment designs to handle fouling conditions appears to be the most practical short term approach. If the fouling problems can be resolved, about 2 quadrillion Btu or \$4 billion in fuel costs annually are considered recoverable with current or near term technology.

In order to make these equipment modifications economically attractive, overdesign must be reduced and reliability increased. In some dirty applications, fouling considerations have nearly doubled the cost of the equipment. Thus, an average equipment cost of \$15,000 per million Btu/hr transferred in clean processes would increase to about \$25,000 per million Btu/hr in dirty gas environments. On this basis, recovery of the available 2 quadrillion Btu/yr of waste energy would require about \$3 billion in additional capital expenditures. Weierman did not break these capital costs down on an annual basis. However, assuming an average 10-year life, the annualized excess capital costs for equipment due to gas-side fouling would be \$300 million per year. In addition to these extra capital costs, Weierman assumed that maintenance costs would also increase. Based on "limited experience," he estimated annual maintenance costs to be about 25 percent of the original equipment costs, compared to about 10 percent under relatively clean operating conditions. Thus, with an initial equipment cost of \$7 billion, the increase in maintenance costs due to gas-side fouling would be about 15 percent or \$1 billion annually. Thus, the total costs due to gas-side fouling on an annual basis would be \$0.3 billion for capital costs and \$1 billion in maintenance costs for a total of \$1.3 billion. Note carefully that this total is less than the \$4 billion given in Reference 7-3 because Weierman did not express his increased capital costs on an annual basis.

7.4 ESTIMATED COSTS OF STEAM SOOTBLOWING

An estimate of the costs of steam sootblowing in U.S. industries has been made by Dyer (Reference 3-38). Consider a watertube steam boiler where he estimated present steam costs to be \$5.33 per 100 lb_m. Allowing time to bleed the steam lines, followed by a blow of 1-3 minutes per nozzle, the cost of steam per nozzle per blowing would be \$0.26. Assuming that there are four sootblowers, each with 15 nozzles, and that they are operated once each 8-hr shift during a 3-shift day, then about \$17,000 is required in steam costs over a 365-day period to clean the boiler surface.

In addition to the boiler surface, an industrial steam generator can also be equipped with a superheater, economizer, air preheater, and in some cases, a reheater. Dyer assumed that an average boiler would include, in addition to the boiler surface, one other heat exchanger. Thus, Dyer's estimated annual costs to clean a typical industrial boiler using sootblowers is about \$34,000. It should be noted that the installed capital cost of the least expensive sootblower is about \$1,000 (Reference 7-4). Thus, in comparison to the operating costs, annualized capital costs are not significant. Using the data presented in Chiogioji (Reference 2-1), where it is estimated that there are presently about 50,000 industrial watertube boilers in this country, along with Dyer's results, the total annual costs of cleaning using steam sootblowers in this country is about \$1.7 billion.

KVB, Inc. carried out a similar analysis in 1980 (Reference 7-5). A representative case reported by KVB for a typical industrial boiler considers three steam sootblowers operating for 1.6 hours per day at a total steam flowrate of 12,000 lb_m/hr. Thus, the cost of operation for 365 days using a steam cost (adjusted to 1983) of \$3.10 per 1000 lb_m is \$21,800 per year. This total represents the sootblowing costs for a single heat exchanger. It should be noted that although the KVB analysis differs from that of Dyer in steam flowrate, blow duration, and steam costs, the two estimates agree within 25 percent.

7.5 ESTIMATED COSTS OF GAS-SIDE FOULING IN CEMENT PLANTS

Marnier (Reference 1-13) has made an estimate of the costs of gas-side fouling on the cement industry in the United States. In order to estimate the value of the energy in the various exhaust streams which are not being utilized in cement plants, the following approach was taken. For each stream the temperature level and total energy content on an annual basis were established. It was then assumed that for each of these streams a Rankine bottoming cycle, utilizing either a steam or an organic fluid boiler, could drive a turbine to produce electrical power which can easily be quantified by assuming a conversion efficiency. For computational purposes, it was assumed that the conversion efficiency varied linearly from a value of zero at 100 F to 35 percent at 1900 F with a maximum efficiency of 40 percent. Using the 1982 industrial cost of electrical energy in the U.S. at \$0.045 per kW-hr, it was thus possible to place a dollar value on each of the exhausted streams.

Estimates were also made as to the annual loss of production costs, increased maintenance costs, and capital costs due to gas-side fouling. The results of this analysis are summarized in Table 7-1 and indicate a total of \$238 million annually, an estimate which is undoubtedly on the conservative side.

Table 7-2. Summary of Estimated Annual Costs in U.S. Cement Plants Due to Gas-Side Fouling, Corrosion, and Erosion (Reference 1-13)

Type of Cost	Estimated Cost (1982 Dollars)
Capital Costs	\$ 5 million
Maintenance Costs	4 million
Loss of Production	108 million
Energy Losses	<u>121 million</u>
Total	\$238 million

7.6 GAS-SIDE FOULING COSTS IN THE PETROLEUM INDUSTRY

A wide variety of heat-transfer equipment is used in the petroleum industry. Furnaces, utilizing waste heat boilers and recuperators, are used for cracking crude oil streams, ethylene processing, etc. In the Shell Oil Company where fuel oil is used as a fuel in operations, gas-side fouling becomes a potential problem. According to E. Barrington (Reference 5-2), Shell estimates that gas-side fouling energy losses amount to about \$1/barrel of oil burned. The current cost of a barrel of oil (42 gallons) is about \$30. Thus, Shell has estimated that gas-side fouling energy losses account for about three percent of their total fuel costs.

Shell's estimate can be extended to the entire petroleum industry by considering the amount of oil consumed in non-feedstock operations such as process steam, direct heating, etc. According to Chiogioji (Reference 2-1) about 55 percent of the oil consumed by the petroleum industry is used in such non-feedstock operations. Based on Chiogioji's data, it is estimated that energy losses due to gas-side fouling in the petroleum industry amount to about \$92 million per year.

Van Nostrand, Leach, and Haluska (Reference 7-6) considered the economic costs due to liquid-side fouling of hydrocarbon streams in the major unit operations found in refineries. Using 1983 dollar values, energy losses were estimated to be \$614 million. Thus, a comparison of the \$92 million from the previous paragraph indicates that gas-side fouling adds about 15 percent to the energy losses due to liquid-side fouling estimated by Van Nostrand et al.

7.7 TOTAL GAS-SIDE FOULING COSTS IN U.S. INDUSTRIES

The information compiled earlier in this section may be used to estimate the total costs of gas-side fouling to U.S. industries on an annual basis. The assumptions made in calculating each of the contributing factors are clearly outlined.

Capital costs are determined from Thackery's work (Reference 7-2). He found that equipment for gas-side service represents about 34 percent of the total U.K. heat exchanger market. Assuming a similar market share in this country, and using a U.S.-to-U.K. Gross National Product (GNP) ratio of seven, the annual sales of capital equipment for gas-side fouling service in the U.S. come to about \$650 million. Using Weierman's estimate (Reference 7-3) that 40 percent of the capital costs are due to gas-side fouling gives a total cost of \$0.3 billion.

Dyer's estimated costs (Reference 3-38) of cleaning will be used as the basis for estimating maintenance costs. It is estimated that cleaning of other types of heat-exchange equipment in the industrial sector will add 20 percent to the estimated costs of Dyer for boilers alone. Thus, on this basis, gas-side fouling costs U.S. industries a total of \$2.1 billion per year for cleaning costs. However, the cleaning costs may be over estimated because no allowance has been made for improved heat transfer and reduced pressure drop as a consequence of cleaning.

Energy losses are determined by taking the ratio of petroleum industry consumption to total energy consumption, taken from Chiogioji (Reference 2-1), times the estimated petroleum industry energy losses of \$92 million/yr as calculated in Section 7.6. Using this approach, the energy losses are estimated to be \$0.9 billion/yr.

Finally, the production losses are estimated using the U.S.-U.K. GNP ratio and Thackery's values. Thus, taking the same approach as used to compute capital costs due to gas-side fouling, the production costs are estimated to be \$0.3 billion/yr.

These results are summarized in Table 7-3 and indicate a total annual cost of \$3.6 billion due to gas-side fouling in the U.S. Clearly, the largest share of the costs estimated in this analysis are the maintenance costs, calculated to be \$2.1 billion/yr, with the energy losses determined to be \$0.9 billion. Although many assumptions were made in this analysis, the total estimate of \$3.6 billion/yr for the cost of gas-side fouling in this country seems to be a reasonable value.

Table 7-3. Estimated Annual Gas-Side Fouling Costs in U.S. Industries

Type of Cost	Estimated Cost
Capital Costs	\$ 0.3 billion
Maintenance Costs	2.1 billion
Loss of Production	0.3 billion
Energy Losses	<u>0.9 billion</u>
Total	\$ 3.6 billion

7.8 SUMMARY

The difficulty in accurately assessing the factors which contribute to the cost of gas-side fouling has severely limited the number of economic analyses which have been carried out in this area. Questionable assumptions are often used in the few analyses which do exist. However, the few totals which do exist suggest that gas-side fouling costs U.S. industries somewhere between \$1 and \$4 billion each year.

The efforts to reduce gas-side fouling costs in individual industries are varied and, in large part, a strong function of the severity of the problem. For example, the cement industry is a substantially smaller fraction of the industrial sector in terms of energy consumption than the petroleum industry. However, energy losses due to gas-side fouling in the cement industry are estimated to be \$121 million/yr compared to \$92 million/yr for the petroleum industry. This comparison reflects the fact that process contaminated exhaust gas streams in cement plants represent more severe industry-wide gas-side fouling problems than those in the petroleum industry.

Finally, it is clear that additional statistics on the number of heat exchangers in operation in this country, along with fairly detailed information relating to gas-side fouling problems in each energy intensive industry, are required if more accurate estimates on the costs of gas-side fouling are to be made.

SECTION 8

ADDITIONAL CONSIDERATIONS RELATING TO GAS-SIDE FOULING

Several additional considerations relating to gas-side fouling are considered briefly in this section. These topics include characterization of combustion gases, gas-side fouling measuring devices, gas-side fouling and corrosion problems related to the burning of waste materials, and dissemination of gas-side fouling information.

8.1 CHARACTERIZATION OF COMBUSTION GASES

Thompson (Reference 3-27), Young (Reference 6-8), and Anson (Reference 8-1) have all emphasized the importance of characterizing combustion gas streams from a fouling point of view. Included here are parameters such as particle loading, particle composition, particle size distribution, gaseous components including excess air, dewpoint temperatures of the various gaseous constituents, and ash fusion temperatures. Factors which strongly influence gas characterization include fuel composition, combustion conditions, and any process contamination which may take place after the fuel has been combusted. In some cases, chemical reactions can also take place downstream of the primary combustion process and this will affect the composition of the gases. Finally, the temperature of the gases will have a strong influence on the state of the particulates and will also be an important factor in the transport processes which take place during the deposition process.

Thompson (Reference 3-27) and others have emphasized the important role which the composition of the fuel plays in the characterization of the combustion gases and in the subsequent gas-side deposition processes. In this connection, the ASME Research Committee on Corrosion and Deposits from Combustion Gases has tabulated the parameters which are used to judge the quality of coal with respect to furnace fouling and slagging. Twenty-six different parameters have been compiled, along with the definition, purpose, and expected precision of measurement for each entry (Reference 1-4).

Diesel engine exhausts are probably better characterized than any other combustion gases. The work done by KVB, Inc. and Garrett AiResearch Manufacturing Company is undoubtedly the major contribution in this area (References 8-2, 8-3). Surveys have been carried out on the characterization of exhaust gases in the cement (Reference 1-13), glass (References 1-4, 8-4), and steel, aluminum, and glass (Reference 8-5) industries. In the high-temperature range, probably more work has been done on characterizing exhaust gases in the glass industry than in any other. However, these surveys have pointed out deficiencies in the characterization of combustion gases in all of these industries. In addition, there are many other industrial gas streams for which the gas characterization must be described as inadequate.

The current state-of-the-art of combustion gas characterization can perhaps best be summed up with the observations of Anson (Reference 8-1):

One of the more important issues relevant to fouling by combustion gases is the relationship between the quantity and nature of the foulants, and the type of fuel and combustion conditions. In my view there are insufficient data to define the nature of dirty gas streams from various industrial systems, and the ways in which these gas streams vary with process conditions and fuels. These data are particularly important at high temperatures (over 1000 F), at which corrosive interactions and chemical bonding are likely to occur, and at low temperatures (below 300 F) at which condensed phases may be present in major quantities. It seems to me that without such data it is not possible to design or select either heat transfer hardware or procedures to mitigate fouling.

The characterization of combustion gases is a very important issue. It is clear that a good understanding of this subject will be required if the basic gas-side fouling mechanisms are to be understood. It is also clear that much additional work needs to be done in this area.

8.2 GAS-SIDE FOULING MEASURING DEVICES

The need for a standardized gas-side fouling probe was emphasized at the Gas-Side Fouling Workshop held in Boulder, Colorado in October 1981 (Reference 1-11). As a first step toward this objective, a survey on gas-side fouling measuring devices has been carried out with the report near completion (Reference 8-6). The survey includes a review of about 25 different devices which have been developed and used to date. Five different types of probes or measuring devices have been identified including:

- (a) Heat flux meters
- (b) Mass accumulation probes
- (c) Optical devices
- (d) Deposition probes
- (e) Acid condensation probes.

A heat flux meter senses the local heat flux to monitor gas-side fouling buildups. To date these devices have been used only in the radiation section of boilers and fired heaters. A mass accumulation probe is a device designed to determine the mass of the deposit quantitatively, whereas a deposition probe collects deposits on a qualitative basis. Optical devices use methods such as interferometry and ellipsometry and at the present time are limited to laboratory investigations. Finally, acid condensation probes are used to collect liquid acid at temperatures below the acid dewpoint.

With one exception -- Rogalski (References 4-6, 4-7), who used a heat-pipe device -- none of the probes developed to date is capable of measuring long-term online gas-side fouling resistances. Although much useful information has been obtained with the probes which have been developed, most of this information is related to deposit analysis, rather than to gas-side fouling resistances per se. As might be expected, gas characterization and deposit analysis are essential in interpreting the results obtained from the probe.

The ideal probe for industrial applications should be simple, robust, lightweight, inexpensive, accurate, capable of monitoring online gas-side

fouling resistances, and capable of testing several different materials simultaneously for corrosion analysis. It should also have a reliable temperature control system so that carefully controlled experiments may be carried out at constant surface temperature. To date, no probe satisfying all these requirements has been developed.

Deposition probes have been used in recovery boilers in the pulp and paper industry, municipal incinerators, and a variety of oil- and coal-fired boiler applications. In addition, a number of laboratory studies have been carried out (Reference 8-6). Williams and Unmack (Reference 3-29, 3-30) have designed and are presently constructing a deposition probe for use in their fluidized bed effort in the aluminum industry described in Section 3. Maberry (Reference 3-9), Bhatti (Reference 8-7), and Tresouthick (Reference 8-8) expressed considerable interest in using a gas-side fouling probe to determine the fouling and corrosion potential of several exhaust gas streams in the cement industry. Other possibilities include the iron and steel, glass, copper, foodstuffs, and textile industries.

In summary, a gas-side fouling probe -- probably in the shape of a cylinder because of the great practical importance of this geometry -- should be designed, constructed, and tested in several typical industrial exhaust gas streams for the purpose of developing an instrument which would become a universally accepted tool by workers in the field. Also, a standardized method of collecting, analyzing, and reporting the data should be formulated. In the development of such an instrument, input from an industrial board should be obtained on a continuing basis throughout the project to ensure that the final product will satisfy the needs and requirements of the industrial sector.

8.3 GAS-SIDE FOULING AND CORROSION PROBLEMS RELATED TO THE BURNING OF WASTE MATERIALS

A tremendous quantity of waste material is produced in this country each year. Agricultural wastes include materials such as sawdust, wood chips, hog fuel, rice hulls, nut shells, fruit pits, and bagasse. Miscellaneous, or

non-agricultural, wastes include garbage, plastics, dirt, metals, refuse, sewage sludge, waste liquids, chemical wastes, waste lube oil, waste solvents, used tires, shredded PVC, paint sludges, etc. These wastes contain a considerable amount of energy with heating values ranging from 3,860 Btu/lb_m for oil sludge to 18,000 Btu/lb_m for polyethylene residue (Reference 8-9).

There is considerable interest in the burning of wastes of all types as was apparent in conversations with several industrial contacts (References 3-9, 3-27, 3-38, 5-1, 5-4, 6-9). In many parts of the country landfills are no longer available; therefore, the possibility of burning waste materials is an option which is receiving more and more attention. If such wastes are burned, tremendous quantities of energy are available in the exhaust gases leaving the thermal oxidizer or incinerator. Unfortunately, trying to recover some of this energy can lead to very severe gas-side fouling and corrosion problems.

The pulp and paper industry has utilized hog fuel, i.e., various wood product wastes used in paper mills, and kraft and sulfite liquor in recovery boiler operations for many years, but not without some difficulties. As was discussed in Section 3, recovery boilers firing these fuels are especially susceptible to Na₂SO₄, Na₂CO₃, and NaCl deposits. Battelle Columbus Laboratories (Reference 3-50) has been engaged in a long-term study to determine the gas-side fouling and corrosion problems resulting from the incineration of refuse, sewage sludge, plastics, rubber, and other solid wastes. The major finding in their studies has been the problem of chloride attack which can cause severe corrosion under both oxidizing and reducing conditions. Thus, one of the major problems in disposing of wastes is the choice of materials to be used in heat-transfer equipment.

Tresouthick (Reference 8-8) has recently reviewed the disposal of wastes such as waste lube oil, waste solvents, petroleum coke, wood chips, sawdust, chlorinated hydrocarbons, acid sludge, municipal refuse, shredded PVC, etc. in cement kilns.

General Portland, Inc. is presently burning wastes in two of its cement plants located in Paulding, Ohio and near Gorman, California (Reference 8-10).

Wastes being used as fuel include 5 million gallons per year of spent solvents, paint residue, used cutting and lube oil, and other materials. The incineration conditions are excellent with combustion temperatures reaching about 3000 F in the rotary kilns, and the residence time of 3.5 seconds produces almost total destruction of the wastes including chlorinated hydrocarbons. However, General Portland recently withdrew its bid to burn wastes in its cement kilns near Dallas, Texas because of local environmental concerns.

Most of the experience with burning wastes has been in municipal incinerators and in pulp and paper mills. However, based on the interest in this topic the industrial incineration of these materials will continue to increase. The variation in the composition of such waste fuel supplies, coupled with the severe downstream gas-side fouling and corrosion problems which can occur, will present a formidable challenge to workers in this field.

8.4 DISSEMINATION OF GAS-SIDE FOULING INFORMATION

During the course of this survey, the problem of gas-side fouling information dissemination to industrial representatives became very apparent. Many of the people contacted were unaware of recent papers, publications, reports, conferences, and other ongoing activities. However, perhaps an even more serious problem is that many of these individuals do not have the time to read and analyze this literature once they have it.

The problem of information dissemination was discussed at the DOE-SERI "Workshop on the Research Needs of Heat Transfer Processes and Equipment" held in Vail, Colorado, in June 1981 (Reference 8-11). Topics of discussion at this workshop dealt with a variety of heat-transfer subjects including fouling and corrosion. During the summary reports, the following comments were presented:

Information dissemination includes critical state-of-the-art surveys and reviews, bibliographies, organized literature retrieval, and design methods.
... A lot of new information is coming out, and this

material must be systematically absorbed, categorized, and put into a useful form. We are hoping for this effort to be successfully translated into information that the designer can use. We feel that this is an important area in which there are major gaps. ... Fouling/corrosion/erosion ... is also an important area in which something like this needs to be done to get more useful information into the hands of the designer.

In the final analysis, the topic of information dissemination was one of five items (out of 21) which was ranked in the high priority category by the participants at this workshop.

In the area of gas-side fouling, bibliographies such as the Fouling Prevention Research Digest published in the United Kingdom (Reference 8-12) and professional development activities such as the ASME Short Course on "Fouling of Heat Transfer Equipment" (Reference 1-19) are steps in the right direction, but much more needs to be done. For example, a number of industrial contacts expressed considerable interest in the "Gas-Side Fouling Bibliography" presented at the 1983 ASME-JSME Thermal Engineering Joint Conference (Reference 1-17). This bibliography includes a list of 206 references which are grouped into either a general category or one of four major categories. Each major-category reference is further grouped into one of several sub-categories and then cross-referenced against the type of fuel. This information is presented in two extensive tables in the paper so that the reader is able to focus immediately on a given topic with a minimum effort. It is this feature of the bibliography that appealed most to those surveyed. However, since this paper includes only selected references since 1970, it was suggested that the paper be expanded and that it also be updated periodically. There was also a great deal of interest expressed in the impending publication of Reference 1-18, an updated version of the Battelle Columbus bibliography originally published in 1970. This volume will include over 2000 references on ash deposits and corrosion and will also include the grouping of references under selected key words to help the reader focus on a given subject area. This publication is in press and is due for release this fall.

There is no easy solution to the problem of gas-side fouling information dissemination. One of the major problems is that many individuals who design, specify, and manufacture heat-transfer equipment have very limited time for such activities. Often these people have major responsibilities in a number of different areas, especially in the smaller companies, which severely limit time for professional development. Therefore, any efforts which convert R&D findings into concise form which are usable to the practicing engineer are especially helpful. On the other hand, employers should develop a greater appreciation for professional development and encourage and support their employees in attending meetings and conferences where technical interchange can take place. The professional societies should probably do more in this area. For example, the ASME Research Committee on Corrosion and Deposits from Combustion Gases and the ASME Heat Transfer Division K-10 Committee on Heat Transfer Equipment should publicize their activities more and explore ways to contribute toward the solution of this problem. Finally, DOE should review its publication policies and seek new ways to disseminate information to the industrial sector to ensure that such information is used and not placed on a shelf to collect dust.

SECTION 9

GAS-SIDE FOULING R&D NEEDS

A variety of topics dealing with gas-side fouling have been presented and discussed in this report. While it is true that considerable progress has been made in solving some of the problems in this area, it is also true that many issues remain unresolved. The purpose of this section is to list specific high-priority R&D needs in the area of gas-side fouling as perceived by industry. In developing these recommendations, emphasis has been placed on generic projects rather than on those dealing with specific industries.

In discussing gas-side fouling R&D needs with industrial representatives, there was essentially unanimous agreement with the seven recommendations made at the 1981 Gas-Side Fouling Workshop in Boulder, Colorado (Reference 1-11). Therefore, as a baseline set of recommendations, those from the Boulder workshop are the first seven listed in Table 9-1. In addition to these recommendations, four additional areas of interest were identified:

- (a) Gas-side fouling and corrosion problems related to the incineration of waste materials.
- (b) Development of materials for gas-side fouling service.
- (c) Additives to mitigate the effects of gas-side fouling.
- (d) Dissemination of gas-side fouling information.

These additional items are also listed in Table 9-1, thus giving a total of 11 high-priority R&D recommendations in the area of gas-side fouling. Using material from both Reference 1-11 and earlier portions of this report as appropriate, a brief explanation of each proposed topic is given below. Additional details may also be found in these sources.

The characterization of combustion gases deals with a determination of the various gaseous components and the properties of the particulate matter in the gases as a function of temperature. Factors which strongly influence gas

Table 9-1. R&D Recommendations for Industrial Gas-Side Fouling

- o Characterization of Combustion Gases
 - o Design, Development, and Testing of a Gas-Side Fouling Measuring Device
 - o Fundamental Studies of Attachment and Removal Mechanisms and the Development of Predictive Methods for Gas-Side Fouling
 - o Experimental Measurement of Gas-Side Fouling Factors for Specific Geometries
 - o Effectiveness of Cleaning Devices for Gas-Side Fouling Service
 - o A Comprehensive Study of the Fouling and Corrosion Mechanisms Associated with Acid Dewpoint Condensation
 - o Development of Alternative Types of Heat-Exchange Equipment to Mitigate the Effects of Gas-Side Fouling
 - o A Study of Gas-Side Fouling and Corrosion Problems Related to the Incineration of Waste Materials
 - o Development of Materials for Gas-Side Fouling Service
 - o A Fundamental Study of Additives to Mitigate the Effects of Gas-Side Fouling
 - o Dissemination of Gas-Side Fouling Information
-

characterization include fuel composition, combustion conditions, and any process contamination which may take place after the fuel has been combusted. Gas characterization is essential in understanding the various gas-side fouling transport processes which take place in heat-transfer equipment. Although exhausts from Diesel engines, and to some extent those from gas turbines, have been reasonably well characterized, this is not the case for most industrial streams. Therefore, a study should be undertaken to characterize the most important industrial combustion gases -- especially the high-temperature streams in the aluminum, cement, copper, glass, and steel industries -- to obtain the information outlined above.

A gas-side fouling probe -- probably in the shape of a cylinder because of the great practical importance of this geometry -- should be designed, constructed, and tested in several typical industrial combustion gas streams. The ideal probe should be simple, robust, lightweight, inexpensive, capable of monitoring online gas-side fouling resistances, and capable of testing several different materials simultaneously for corrosion analysis, and it should also have a reliable temperature control system. In addition, a standardized method of collecting, analyzing, and reporting the data should be formulated. The purpose of developing such an instrument, which requires key input from industry, is to create a universally accepted tool for workers in the field of gas-side fouling.

Using the gas-side fouling measuring device, or probe, described in previous paragraph as a tool, fundamental studies of attachment and removal mechanisms may be carried out. A comprehensive effort -- in which gas composition, gas temperature, surface temperature, gas velocity, and other important parameters are systemically varied -- is needed here. Once a good understanding of the basic gas-side attachment and removal mechanisms are quantitatively understood, specific methods for gas-side fouling predictive methods also need to be developed.

Gas-side fouling factors for design purposes which are experimentally based are virtually non-existent. Except for gas turbine and Diesel engine exhausts, most of the fouling factors used today are based on experience rather

than on actual data. Therefore, a study should be carried out using specific geometries in typical gas streams to obtain experimental transient gas-side fouling factors. These data should be obtained as a function of gas composition, gas temperature, surface temperature, gas velocity, and other parameters of interest. If necessary, scoping studies could be used initially to limit the amount of data collected.

Additional information is needed on the effectiveness of cleaning devices for gas-side fouling service. A systematic study should be carried out to determine how well various cleaning devices remove typical deposits from several commonly used heat-transfer surfaces. Cleaning techniques tested should include conventional ones such as air and water sootblowing and water washing, as well as sonic sootblowing and selected mechanical, and thermal techniques. The objective of this investigation is to establish some specific guidelines so that the designer is in a position to specify the best type of cleaning for a specific geometry and type of deposit.

One of the major problems in low-temperature heat recovery is that of gas-side fouling and corrosion associated with acid dewpoint condensation. Therefore, a study should be carried out in this environment to:

- (a) Determine experimental gas-side fouling factors under transient conditions as a function of gas composition, gas temperature, surface temperature, gas velocity, and other important parameters.
- (b) Identify accommodation techniques such as additives, material selection including coatings, cleaning methods, and appropriate shutdown, startup, and transient operating conditions to minimize the effects of this problem.

Conventional heat-transfer equipment such as recuperators and regenerators has been in existence for many years. More recently, alternative types of heat-exchange equipment such as direct contact and fluidized bed heat exchangers have been developed to mitigate the effects of gas-side fouling and corrosion. Continued development of such alternative types of heat exchangers should be given high-priority as a tool in overcoming the problems of gas-side fouling and corrosion.

Considerable interest has been expressed in the incineration of a wide variety of agricultural and miscellaneous waste materials. Therefore, a study should be undertaken to determine the gas-side fouling and corrosion characteristics related to the burning of selected waste materials. Parameters of particular interest in such a study include gas composition, gas temperature, gas velocity, surface geometry, and surface material, and variation of fuel supply.

The development of materials for gas-side fouling and corrosion service is a very important consideration. Studies should be initiated to identify appropriate materials and coatings for use in:

- (a) Low-temperature service where acid dewpoint condensation is a potential problem.
- (b) High-temperature service where the use of ceramics may be the only possible solution.

There is also a need for continued development of stainless steels and superalloys for use in intermediate-temperature applications where corrosion is a problem.

Although the use of magnesium-based additives has been widely employed in connection with oil-fired systems, the mechanism by which such additives are successful in mitigating the effects of gas-side fouling is not completely understood. Therefore, a fundamental study should be carried out to:

- (a) Obtain a better understanding of why additives are successful in mitigating gas-side fouling in some cases and not in others.
- (b) Develop new and improved additives.

Such a test program should include the use of residual oils, coal, and some of the developing fuels such as coal-water mixtures.

The dissemination of gas-side fouling information is an important issue. Many individuals who design, specify, and manufacture heat-transfer equipment have very limited time for such activities. Therefore, any efforts which convert R&D findings into a concise, usable form for the engineer are especially helpful. Unfortunately, there is no easy solution to the problem of gas-side fouling information dissemination. Bibliographies and review articles are a step in the right direction, but much more needs to be done. Employers, employees, professional societies, and DOE all should try to find solutions to this problem. In particular, DOE should review its publication policies and seek new ways to disseminate information to the industrial sector to ensure that such information is used and not placed on a shelf to collect dust.

REFERENCES

- 1-1. "Corrosion and Deposits from Combustion Gases: Abstract and Index". Battelle Memorial Institute, Columbus Laboratories, Columbus, Ohio, 1970.
- 1-2. Reid, W.T., External Corrosion and Deposits: Boilers and Gas Turbines, American Elsevier, New York, New York, 1971.
- 1-3. Taborek, J., Aoki, T., Ritter, R.B., Palen, J.W. and Knudsen, J.G. "Fouling - The Major Unresolved Problem in Heat Transfer," AIChE Reprint 7, American Institute of Chemical Engineers, New York, 1971.
- 1-4. Winegartner, E.C. (Editor), "Coal Fouling and Slagging Parameters," Research Committee on Corrosion and Deposits from Combustion Gases, ASME, New York, 1974.
- 1-5. Bryers, R.W. (Editor), Ash Deposits and Corrosion Due to Impurities in Combustion Gases, Hemisphere, Washington, D.C., 1978.
- 1-6. Bryers, R.W. (Editor), Experimental Research into Fouling and Slagging Due to Impurities in Combustion Gases, Engineering Foundation, New York, (In Press).
- 1-7. Epstein, N., "Fouling in Heat Exchangers," Proceedings of the Sixth International Heat Transfer Conference, Vol. 6, 1978, pp. 235-253.
- 1-8. Somerscales, E.F.C. and Knudsen, J.G. (Editors), Fouling of Heat Transfer Equipment, Hemisphere, Washington, D.C., 1981.
- 1-9. "Electric Utility Use of Fireside Additives," EPRI Report No. CS-1318, Battelle Columbus Laboratories, Columbus, Ohio, 1980.
- 1-10. Lansing, N.F. (Editor), "Workshop Proceedings: Applications of Fireside Additives to Utility Boilers," EPRI Report No. WS-80-127, Battelle Columbus Laboratories, Columbus, Ohio, 1981.
- 1-11. Marner, W.J. and Webb, R.L. (Editors), "Workshop on an Assessment of Gas-Side Fouling in Fossil Fuel Exhaust Environments," Publication 82-67, Jet Propulsion Laboratory, California Institute of Technology, Pasadena, California, 1982.
- 1-12. Bryers, R.W. (Editor) Proceedings of the International Conference on the Fouling of Heat Exchanger Surfaces, Engineering Foundation, New York, (In Press).

- 1-13. Marner, W.J., "An Assessment of Gas-Side Fouling in Cement Plants," Publication 82-83, Jet Propulsion Laboratory, California Institute of Technology, Pasadena, California, 1982.
- 1-14. Webb, R.L. and Kulkarni, A.K., "Heat Exchanger Needs for Recovering Waste Heat in the Glass Making Industry", Final Report, DOE/ID/12225, The Pennsylvania State University, University Park, Pennsylvania, February 1983.
- 1-15. Knudsen, J.G., "Fouling in Heat Exchangers," Presented at the Seventh International Fouling Conference, Munich, Germany, 1982.
- 1-16. Fassbender, L. L. (Editor), "Proceedings of the PNL Fouling and Corrosion Workshop," Battelle, Pacific Northwest Laboratory, Richland, Washington, September 1983.
- 1-17. Marner, W.J. and Webb, R.L., "A Bibliography on Gas-Side Fouling", ASME-JSME Thermal Engineering Joint Conference, Vol. 1, 1983, pp. 559-570.
- 1-18. Radway, J.E. (Editor), Corrosion and Deposits from Combustion Gases, Second Edition, Hemisphere, Washington, D.C., (In Press).
- 1-19. Marner, W.J. and Suitor, J.W., "Fouling of Heat Transfer Equipment," ASME Short Course, Seattle, Washington, July 1983.
- 1-20. U.S. Office of Management and Budget, "Standard Industrial Classification Manual," General Printing Office, Washington, D.C. 1972.
- 2-1. Chiogioji, M.H., Industrial Energy Conservation, Marcel Dekker, New York, 1979.
- 3-1. Ganapathy, V., Applied Heat Transfer, PennWell Publishing Company, Tulsa, Oklahoma, 1982.
- 3-2. Patterson-Kelley Company, East Stroudsburg, Pennsylvania.
- 3-3. Van Wylen, G.J. and Sonntag, R.E., Fundamentals of Classical Thermodynamics, John Wiley, New York, 1965.
- 3-4. Kentube, Division of Tranter, Inc., Tulsa, Oklahoma.
- 3-5. Tran, H.N., Reeve, D.W., and Barham, D., "The Effect of Fireside Deposits on Kraft Recovery Boiler Superheater Corrosion," Preprint No. 28-1, Presented at 21st Annual Conference of Metallurgists, The Canadian Institute of Mining and Metallurgy, Toronto, Canada, August 29 - September 1, 1982.

- 3-6. Tran, H.N. and Reeve, D.W., "Kraft Recovery Unit Fireside Deposits and Plugging," Presented at the 69th CPPA Annual Meeting, Montreal, Canada, January 31 - February 4, 1983.
- 3-7. Brock Turbulators, New York, New York.
- 3-8. Smith Engineering Company, Duarte, California.
- 3-9. Maberry, J., Smith Engineering Company, Duarte, California, Personal Communication, February 1982.
- 3-10. Escoa Fintube Corporation, Pryor, Oklahoma.
- 3-11. Csathy, D., "Heat Recovery from Dirty Gas," Presented at the Sixth National Conference on Energy and the Environment, Pittsburgh, Pennsylvania, May 1979.
- 3-12. Smittle, D., "Maximize Heat Recovery from Hot Flue Gas with Finned Tubing," Energy Processing/Canada, Vol. 73, No. 5, 1981, pp. 18, 20-21.
- 3-13. DeAnda, E., "Heat Exchanger Fouling and Corrosion Evaluation," Report No. 81-18003, AiResearch Manufacturing Company of California, Torrance, California, June 1981.
- 3-14. Profos, P. and Sharan, H.N., "Effect of Tube Spacing and Arrangement upon the Fouling Characteristics of Banks of Tubes," Sulzer Technical Review, Vol. 42, No. 4, 1960, pp. 31-43.
- 3-15. Weierman, C., Taborek, J. and Manner, W.J., "Comparison of the Performance of In-Line and Staggered Banks of Tubes with Segmented Fins," AIChE Symposium Series, Vol. 74, No. 174, 1978, pp. 39-46.
- 3-16. Hutchins, W.H. and Grabowski, W.V., "High Effectiveness Recuperator for Waste Heat Recovery Applications," Paper No. 80-WA/HT-15, ASME, 1980.
- 3-17. Greeven, M., AiResearch Manufacturing Company, Torrance, California, Personal Communication, August 1983.
- 3-18. Eastwood, J.C., "High-Performance Metallic Recuperator for Industrial Flue Gas Heat Recovery," Report No. 81-18198, AiResearch Manufacturing Company, Torrance, California, September 1981.
- 3-19. Shah, R., Harrison Radiator Division, General Motors Corporation, Lockport, New York, Personal Communication, September 1983.
- 3-20. Hirschey, N., Mobil Oil Corporation, Torrance, California, Personal Communication, September 1983.

- 3-21. Krowech, R., "Evaluation of Fouling in Fluid Catalytic Cracker Boilers," Presented at the International Conference on Fouling of Heat Exchanger Surfaces, White Haven, Pennsylvania, October 31 - November 5, 1982.
- 3-22. Steam: Its Generation and Use, Babcock and Wilcox, Barberton, Ohio, 1975.
- 3-23. Berry, E.E., Kraszewski, L. and Luckman, C.G., "An Evaluation of Electrical Co-Generation for Waste Heat Recovery in the Cement Industry," Energy, Mines and Resources Canada, Canada, February 1981.
- 3-24. Bhatti, M.S.Y., "Cement Kiln System Buildups," Proceedings of the 16th International Cement Seminar, Chicago, Illinois, 1981, pp. 110-115
- 3-25. "The KVB CHR.....Condensation Heat Recoverer," KVB, Inc., Irvine, California.
- 3-26. Thompson, R.E., "Condensing Flue-Gas Water Vapor: Another Way to Cut Your Fuel Bill," Power, Vol. 27, No. 5, 1983, pp. 79-82.
- 3-27. Thompson, R.E., KVB, Inc., Irvine, California, Personal Communication, September 1983.
- 3-28. Rudnicki, M.I., Mah, C.S. and Williams, H.W., "Status of Fluidized Bed Waste Heat Recovery," in Taborek, J., Hewitt, G.F. and Afgan, N. (Editors), Heat Exchangers: Theory and Practice, Hemisphere, Washington, D.C., 1983, pp. 549-568.
- 3-29. Unmack, K., Aerojet Energy Conversion Company, Sacramento, California, Personal Communication, March 1983.
- 3-30. Williams, H.W., Aerojet Energy Conversion Company, Sacramento, California, Personal Communication, March 1983.
- 3-31. Strumpf, H.J. and Miller, W.S., "Ceramic Heat Pipe Recuperator Study," Report No. 79-16480, AiResearch Manufacturing Company of California, Torrance, California, May 1980.
- 3-32. Murray, P.F., Monsanto Chemical Intermediates Company, Alvin, Texas, Personal Communication, June 1983.
- 3-33. Meith, H.C., Energy Technology, Inc. (ENTEC), Houston, Texas, Personal Communication, June 1983.
- 3-34. API RP 533, American Petroleum Institute, Washington, D.C.
- 3-35. Sotter, J.G., KVB, Inc. Irvine, California, Personal Communication, September 1983.

- 3-36. "Cold-End Temperature and Material Selection Guide," C-E Air Preheater, Combustion Engineering Inc., Wellsville, New York, 1978.
- 3-37. Miller, D., Holtz, R.E., Koopman, R.N., Marciniak, T.J. and MacFarlane, D.R., "Plastic Heat Exchangers: A State-of-the-Art Review," Report No. ANL-79-12, Argonne National Laboratory, Argonne, Illinois, July 1979.
- 3-38. Dyer, D., Kentube Division of Tranter, Inc., Tulsa, Oklahoma, Personal Communication, June 1983.
- 3-39. Weierman, R.C., Escoa Fintube Corporation, Pryor, Oklahoma, Personal Communication, June 1983.
- 3-40. Reay, D.A., "A Review of Gas-Gas Heat Recovery Systems," Journal of Heat Recovery Systems, Vol. 1, 1981, pp. 3-41.
- 3-41. "Heat Recovery System," Manufacturing Technology Horizons, Vol. 1, No. 5, 1982, pp. 18-19.
- 3-42. Ruston, M., Corning Glass Works, Big Flats, New York, Personal Communication, September 1983.
- 3-43. Wolverine Tube Division, UOP Inc., Decatur, Alabama.
- 3-44. High Performance Tube, Inc. (HPTI), Union, New Jersey.
- 3-45. Lasebe, B.A. and Devitt, T.W., "Status of Flue Gas Desulfurization," Chemical Engineering Progress, Vol. 75, No. 2, 1979, pp. 37-50.
- 3-46. O'Donnell, J., Jr., Morgan, H. and Glass, J.P., "A New Approach: Using Integrally Finned High Performance Alloy Tubes in Direct Line FGD Reheaters," ASME Paper No. 82-JPGC-Pwr-2, Presented at the Joint Power Generation Conference, Denver, Colorado, October 1982.
- 3-47. Glass, J.P., The Happy Division, Therma Technology, Inc., Tulsa, Oklahoma, Personal Communication, June 1983.
- 3-48. O'Donnell, J., Jr., High Performance Tube, Inc., Union, New Jersey, Personal Communication, September, 1983.
- 3-49. Grove, E.E., John Zink Company, Tulsa, Oklahoma, Personal Communication, June 1983.
- 3-50. Krause, H.H., Cover, P.W., Berry, W.E. and Olexsey, R.A., "Corrosion and Deposits from Combustion of Solid Waste. Part VII: Coincineration of Refuse and Sewage Sludge," ASME Journal of Engineering for Power, Vol. 102, 1980, pp. 698-705.

- 3-51. Dobos, C.J., Gas Research Institute, Chicago, Illinois, Personal Communication, August 1983.
- 3-52. Coombs, M., Kotchick, D. and Strumpf, H., "High-Temperature Ceramic Recuperator and Combustion Air Burner Programs," Report No. 83-19870, AiResearch Manufacturing Company, Torrance, California, April 1983.
- 3-53. Russell, A.D., Smeltzer, C.E. and Ward, M.E., "Waste Heat Recuperation for Aluminum Furnaces," Report No. GRI-81/0160, Solar Turbines Incorporated, San Diego, California, April 1983.

- 4-1. Weierman, R.C., "Design of Heat Transfer Equipment for Gas-Side Fouling Service," in Marnier, W.J. and Webb, R.L. (Editors), "Workshop on an Assessment of Gas-Side Fouling in Fossil Fuel Exhaust Environments," Publication 82-67, Jet Propulsion Laboratory, California Institute of Technology, Pasadena, California, July 1982.
- 4-2. "Technical Information for Heat Recovery Seminar," John Zink Company, Tulsa, Oklahoma, 1981.
- 4-3. Tubular Exchanger Manufacturers Association, New York, New York.
- 4-4. Chenoweth, J.M., Heat Transfer Research, Inc., Alhambra, California, Personal Communication, February 1982.
- 4-5. Henslee, S.P. and Bogue, J.L., "Fouling of a Finned-Tube Heat Exchanger in the Exhaust of a Stationary Diesel Engine: Final Report," DOE Contract No. DE-AC07-76ID01570, EG&G Idaho, Inc., Idaho Falls, Idaho, March 1983.
- 4-6. Rogalski, R.D., "Fouling Effects of Turbine Exhaust Gases on Heat Exchanger Tubes for Heat Recovery Systems," Report No. DTNSRDC-PAS-79/5, David W. Taylor Naval Ship R&D Center, Bethesda, Maryland, February 1979.
- 4-7. Rogalski, R.D., "Fouling Effects of Turbine Exhaust Gases on Heat Exchanger Tubes for Heat Recovery Systems," SAE Transactions, Vol. 88, Section 3, No. 790647, 1979, pp. 2223-2239.
- 4-8. Munn, W.B., Amoco Production Company, Houston, Texas, Personal Communication, June 1983.

- 5-1. Watts, D.O., Energy Recovery Inc., Tulsa, Oklahoma, Personal Communication, June 1983.

- 5-2. Barrington, E.A., Shell Oil Company, Houston, Texas, Personal Communication, July 1983.
- 5-3. Theoclitus, G., C E - Air Preheater Company, Wellsville, New York, Personal Communication, October 1981.
- 5-4. Eriksen, V.L., Deltak Corporation, Minneapolis, Minnesota, Personal Communication, July 1983.
- 5-5. Miller, P.D. and Krause, H.H., "Factors Influencing the Corrosion of Boiler Steels in Municipal Incinerators," Corrosion-NACE, Vol. 27, No. 1, 1971, pp. 31-45.
- 5-6. Greenlee, W.J. and Berger, R.W., "Gas-Side Fouling Experience in the Waste Heat Boiler of a 600 kWe Organic Rankine Bottoming Cycle," Presented at the International Conference on Fouling of Heat Exchanger Surfaces, White Haven, Pennsylvania, October 31 - November 5, 1982.
- 5-7. Niggeman, R.E. and Greenlee, W.J., "The Design, Performance, and Operating Experience of the Heat Transfer Equipment in the Sundstrand 600 kW Organic Rankine Bottoming Cycle," Advancement in Heat Exchangers, International Centre for Heat and Mass Transfer 1981 Summer Seminar, Dubrovnik, Yugoslavia, September 1981.
- 5-8. Berger, R.E., "Fouling and Acid Corrosion of an Organic Rankine Bottoming System Vaporizer Exposed to Diesel Engine Exhaust, Easton, Maryland," Sundstrand Engineering Report No. AER 1835, Sundstrand Aviation Operations, Rockford, Illinois, October 1980.
- 5-9. Greenlee, W.J., Sundstrand Corporation, Rockford, Illinois, Personal Communication, November 1982 and August 1983.
- 5-10. Hung, W., "Results of a Firetube Test Boiler in Flue Gas with Hydrogen Chloride and Fly Ash," ASME Paper No. 75-WA/HT-39, Presented at Winter Annual Meeting, Houston, Texas, November 1975.
- 6-1. Essenhigh, R.H. "Coal Combustion," in Wen, C.Y. and Lee, E.S. (editors), Coal Conversion Technology, Addison - Wesley, Reading, Massachusetts, 1979, pp. 171-312.
- 6-2. White, D.J., "Effects of Gas Turbine Combustion on Soot Deposition," Final Report, Contract No. N0001478-C-003, Solar Turbines International, San Diego, California, March 1979.
- 6-3. Radway, J.E., "Effectiveness of Fireside Additives in Coal-Fired Boilers," Power Engineering, Vol. 82, No. 4, 1978, pp. 72-75.

- 6-4. Libutti, B.L., "Efficient Cold-End Additives," Symposium on Heavy Fuel Additives, Vol. 21, No. 1, AIChE, New York, 1976, pp. 23-24.
- 6-5. Krause, H.H., Rising, B.W., Anson, D., Radway, J.E. and Dimmer, J.P., "Performance of Fuel Oil Additives on Simulated Superheater Surfaces," ASME Paper No. 82-JPGC-FU-5, 1982.
- 6-6. McMillan, D.B., "Cold End Treatment Solves Air Heater Corrosion Problems," Combustion, Vol. 49, No. 6, 1977, pp. 29-31.
- 6-7. DiCarlo, J.T., "Guidelines Aid in Application, Operation of Soot Blowers," The Oil and Gas Journal, Vol. 77, No. 19, 1972, pp. 88-96.
- 6-8. St. Regis Paper Company, Kraft Division, Plant Tour, Tacoma, Washington, July 1983.
- 6-9. Young, J.D., John Zink Company, Tulsa, Oklahoma, Private Communication, June 1983.
- 6-10. Honka, I., Kuukkanen, K.K., Malmivuori, P. and Aksela, R., "Computer Control of Sulfite Recovery Boiler" Chemical Engineering Progress, Vol. 79, No. 9, 1983, pp. 31-35.
- 6-11. Schwartz, J.A., KVB, Inc., Irvine, California, Personal Communication, September 1983.
- 6-12. Berlant, M.J. and Schwartz, J.A., "An Application Summary of High Energy Sonic Cleaning Applied to Electrostatic Precipitators," Presented at the Third Symposium on the Transfer and Utilization of Particulate Control Technology, Orlando, Florida, March 1981.
- 6-13. Lange, H.B. and Schwartz, J.A., "Application of a Low-Frequency Sonic Cleaning Method to Control Deposits in Boilers and Precipitators," Presented at the Technical Association of the Pulp and Paper Industry Engineering Conference, Washington, D.C., September 1980.
- 6-14. Locke, J.W., Diamond Power Specialty Company, Lancaster, Ohio, Personal Communication, October 1981.
- 6-15. "Soot Blowing and Water Washing Equipment and Procedures," C E-Air Preheater, Combustion Engineering, Inc., Wellsville, New York, 1976
- 6-16. Consec, Inc., Medford, Wisconsin.
- 6-17. Burgmeier, L. and Leung, S., "Heat Exchanger and Cleaning System Test Report," Report No. 81-17932, AiResearch Manufacturing Company, Torrance, California, August 1981.

- 6-18. "Positive Pressure Heat Exchanger Cleaning System Test Report," Report No. 81-18259, AiResearch Manufacturing Company, Torrance, California, October 1981.
- 6-19. Wieland, G., Bethlehem Steel Corporation, Bethlehem, Pennsylvania, Personal Communication, August 1983.
- 6-20. Reay, D., Presentation at International Energy Agency Meeting, Idaho Falls, Idaho, June 1983.
- 7-1. Radway, J.E., Thielke, J. and Marshall, F., "Control of Plume Opacity on an Oil-Fired Boiler," Presented at the ASME Winter Annual Meeting, New York, 1979.
- 7-2. Thackery, P.A., "The Cost of Fouling in Heat Exchange Plant," Effluent and Water Treatment Journal, Vol. 20, 1980, pp. 112-115.
- 7-3. Weierman, R.C., "Impact of Fossil Fuel Gas-Side Fouling on Energy Utilization," in Marner, W.J. and Webb, R.L. (Editors), "Workshop on an Assessment of Gas-Side Fouling in Fossil Fuel Exhaust Environments," Publication 82-67, Jet Propulsion Laboratory, California Institute of Technology, Pasadena, California, July 1982.
- 7-4. Weierman, R.C., Escoa Fintube Corporation, Pryor, Oklahoma, Personal Communication, September 1983.
- 7-5. "A Comparison of the Operating Costs of Acousticlean Sonic Sootblowers with Conventional Steam Sootblowers," KVB Inc., Irvine, California, March 1980.
- 7-6. Van Nostrand, Jr., W.L., Leach, S.H. and Haluska, J.L., "Economic Penalties Associated with the Fouling of Refinery Heat Transfer Equipment," in Somerscales, E.F.C. and Knudsen, J.G., Fouling of Heat Transfer Equipment, Hemisphere, Washington, D.C., 1981, pp. 619-643.
- 8-1. Anson, D., Battelle Columbus Laboratories, Columbus, Ohio, Private Communication, August 1983.
- 8-2. Engel, P.K., Thompson, R.E. and Silvestrini, R., "Corrosion and Fouling Potential in Diesel Exhausts," ASME Journal of Engineering for Power, Vol. 101, 1979, pp. 598-606.
- 8-3. Kindlimann, L. and Silvestrini, R., "Heat Exchanger Fouling and Corrosion Evaluation," Report Nos. 78-15161 (1) and (2), AiResearch Manufacturing Company of California, Torrance, California, April 1979.

- 8-4. "Flue Gas Characterization Literature Search," Report No. 80-16900, AirResearch Manufacturing Company of California, Torrance, California, March 1980.
- 8-5. Wikoff, P.M., Wiggins, D.J., Tallman, R.L. and Forkel, C.E. "High-Temperature Waste Heat Stream Selection and Characterization," Report No. EGG-SE-6349, EG&G Idaho, Inc., Idaho Falls, Idaho, August 1983.
- 8-6. Marner, W.J., and Henslee, S.P., "A Survey of Gas-Side Fouling Measuring Devices," Jet Propulsion Laboratory, California Institute of Technology, Pasadena, California (In Preparation).
- 8-7. Bhatti, M.S.Y., Portland Cement Association, Skokie, Illinois, Personal Communication, August 1983.
- 8-8. Tresouthick, W.S., Portland Cement Association, Skokie, Illinois, Personal Communication, August 1983.
- 8-9. Boyen, J.L., Thermal Energy Recovery, Second Edition, John Wiley, New York, 1980.
- 8-10. "Burning of Waste in Cement Kilns," Chemical Engineering, Vol. 90, No. 16, 1983, p. 11.
- 8-11. Larson, R. and Kreith, F. (Editors), "Workshop on the Research Needs of Heat Transfer Processes and Equipment," Report No. SERI/CP-252-1360, Solar Energy Research Institute, Golden, Colorado, October 1981.
- 8-12. Fouling Prevention Digest, AERE Harwell, Oxon, United Kingdom.

APPENDIX A

List of Industrial Organizations Visited

APPENDIX A

List of Industrial Organizations Visited

A number of industrial organizations were visited during the course of this study to obtain information on gas-side fouling and related topics. These organizations, in chronological order of visitation, are:

Smith Engineering Company
1718 Highland Avenue
Duarte, CA 91010
March 24 and June 9, 1983

Aerojet Energy Conversion Company
P.O. Box 13222
Sacramento, CA 95813
March 11, 1983

Technotherm Corporation
5505 West 66th Street South
Tulsa, OK 74131
June 20, 1983

Energy Recovery, Inc.
P.O. Box 54189
Tulsa, OK 74155
June 21, 1983

Energy Technology, Inc. (ENTEC)
Number One Riverway 2300
Houston, TX 77056
June 21, 1983

Industrial Fabricating Company
P.O. Box 54710
10055 East 56th Street North
Tulsa, OK 74145
June 21, 1983

Amoco Production Company
P.O. Box 4381
Houston, TX 77210
June 21, 1983

The John Zink Company
4401 South Peoria
Tulsa, OK 74105
June 22, 1983

The M.W. Kellogg Company
Three Greenway Plaza East
Houston, TX 77046
June 22, 1983

The Happy Division
Therma Technology, Inc.
P.O. Box 2739
Tulsa, OK 74101
June 22, 1983

Engineers and Fabrication Company
3501 West 11th Street
P.O. Box 7395
Houston, TX 77008
June 22, 1983

Kentube Division
Tranter, Inc.
4150 South Elwood
Tulsa, OK 74107
June 23, 1983

Exxon Research and Engineering
P.O. Box 4255
Baytown, TX 77520
June 23, 1983

Escoa Finatube Corporation
P.O. Box 399
Pryor, OK 74361
June 24, 1983

Monsanto Chemical Intermediates Co.
Chocolate Bayou Plant
P.O. Box 711
Alvin, TX 77511
June 24, 1983

St. Regis Paper Company
Kraft Division
P.O. Box 2133
Tacoma, WA 98401
July 27, 1983

AiResearch Manufacturing Company
2525 West 190th Street
Torrance, CA 90509
August 5, 1983

Gas Research Institute
8600 West Bryn Mawr Avenue
Chicago, IL 60631
August 8, 1983

Portland Cement Association
5420 Old Orchard Road
Skokie, IL 60077
August 8, 1983

KVB, Inc.
18006 Skypark Boulevard
Irvine, CA 92714
September 23, 1983

APPENDIX B

List of Conferences, Meetings, Workshop,
and Short Courses Attended



APPENDIX B

List of Conferences, Meetings, Workshop, and Short Courses Attended

The following conferences, meetings, workshops, and short courses -- listed in chronological order -- were attended just prior to or during the course of this study:

Fouling and Corrosion Workshop
Battelle, Pacific Northwest Laboratory
Seattle, Washington
December 21, 1982

International Conference on the
Fouling of Heat Exchanger Surfaces
White Haven, Pennsylvania
October 31 - November 5, 1982

Technical Advisory Committee Meeting
Heat Transfer Research, Inc. (HTRI)
Pasadena, California
February 8-10, 1983

ASME-JSME Thermal Engineering Joint Conference
Honolulu, Hawaii
March 20-24, 1983

International Energy Agency Meeting
Idaho Falls, Idaho
June 7, 1983

Technical Advisory Committee Meeting
Heat Transfer Research, Inc. (HTRI)
Seattle, Washington
July 20-22, 1983

AICHE-ASME National Heat Transfer Conference
Seattle, Washington
July 25-27, 1983

Fouling of Heat Transfer Equipment
ASME Short Course
July 28, 1983