

NASA Technical Memorandum 83651

NASA-TM-83651 19840014954

A 37.5-kW Point Design Comparison of the Nickel-Cadmium Battery, Bipolar Nickel-Hydrogen Battery, and Regenerative Hydrogen-Oxygen Fuel Cell Energy Storage Subsystems for Low Earth Orbit

Michelle A. Manzo and Mark A. Hoberecht
Lewis Research Center
Cleveland, Ohio

LIBRARY COPY

OCT 25 1984

LANGLEY RESEARCH CENTER
LIBRARY, NASA
HAMPTON, VIRGINIA

Prepared for the
Nineteenth Intersociety Energy Conversion Engineering Conference
cosponsored by the ANS, ASME, SAE, IEEE, AIAA, ACS, and AIChE
San Francisco, California, August 19-24, 1984

NASA

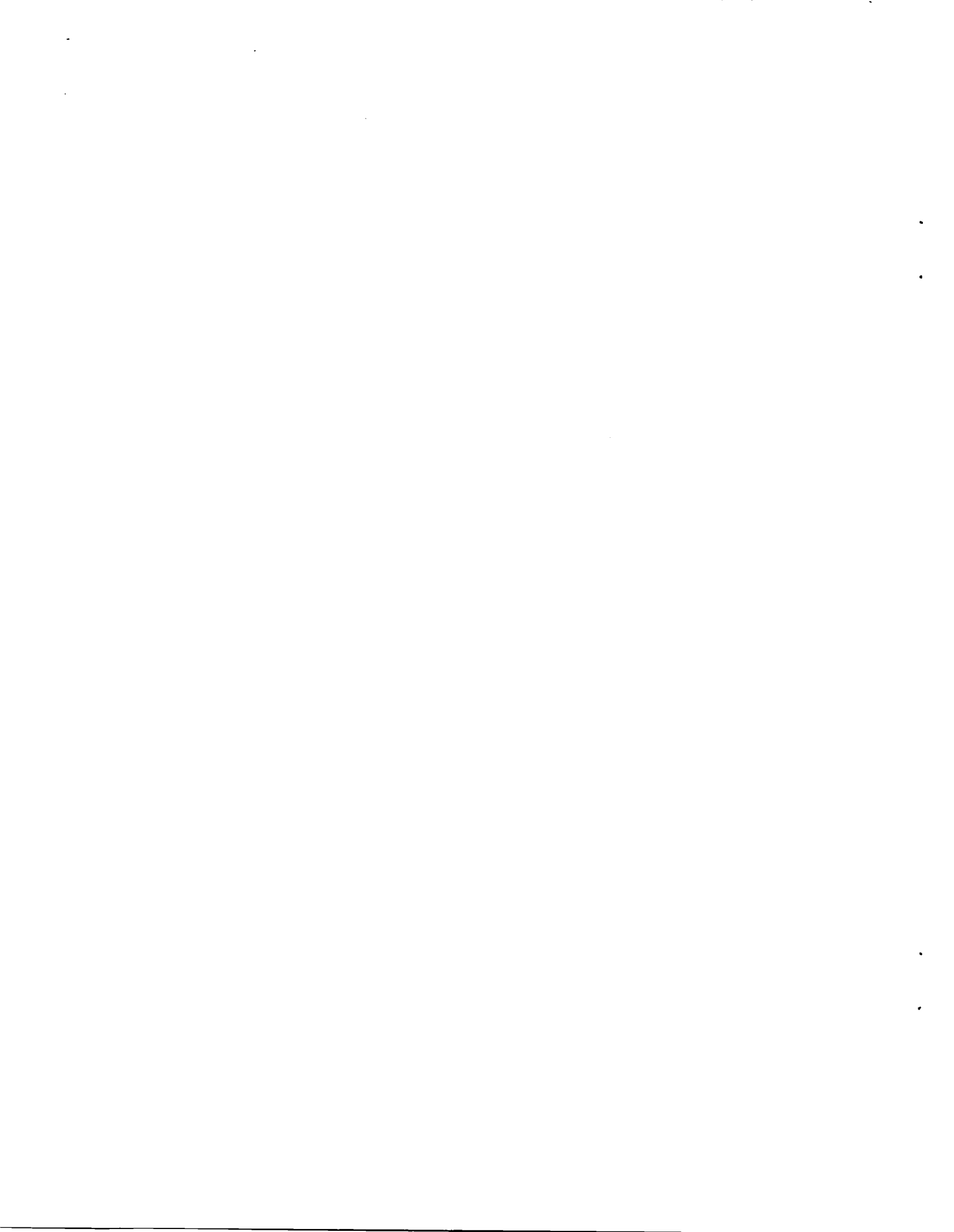

A 37.5-kW POINT DESIGN COMPARISON OF THE NICKEL-CADMIUM BATTERY,
BIPOLAR NICKEL-HYDROGEN BATTERY, AND REGENERATIVE
HYDROGEN-OXYGEN FUEL CELL ENERGY STORAGE
SUBSYSTEMS FOR LOW EARTH ORBIT

Michelle A. Manzo and Mark A. Hoberecht
National Aeronautics and Space Administration
Lewis Research Center
Cleveland, Ohio 44135

ABSTRACT

Nickel-cadmium batteries, bipolar nickel-hydrogen batteries, and regenerative fuel cell storage subsystems were evaluated for use as the storage subsystem in a 37.5 kW power system for space station. Design requirements were set in order to establish a common baseline for comparison purposes. The storage subsystems were compared on the basis of effective energy density, round trip electrical efficiency, total subsystem weight and volume, and life.

INTRODUCTION

Space station power requirements are expected to range from an initial level of 75 kW to a growth level of 150 kW. These are much higher power levels than have been flown on spacecraft to date. An analysis of power systems is required to determine effective methods of handling these higher power levels. As part of an overall power systems study, which included both dynamic and photovoltaic concepts, a study was performed to compare electrochemical storage subsystems that, coupled with a solar array and appropriate management devices, could provide the required power and energy. Nickel-cadmium (Ni-Cd) batteries, bipolar nickel-hydrogen (Ni-H₂) batteries, and regenerative fuel cell (RFC) storage subsystems were the technologies compared. Design requirements were set in order to establish a common baseline for comparison purposes. The resource module for the space station has been split into two units each of which would provide 37.5 kW, as such, modular, 37.5 kW storage subsystems were designed for low earth orbit (LEO) operation. As power levels increase multiple units are placed on each bus. The design results are presented. The subsystems were compared on the basis of effective energy density, round trip electrical efficiency, total subsystem weight and volume, and life. An effort was

made to evaluate manageability, failure modes, and safety aspects of each system.

DESIGN REQUIREMENTS

The design requirements for the 37.5 kW point design comparing nickel-cadmium batteries, nickel-hydrogen batteries, and hydrogen-oxygen regenerative fuel cell energy storage subsystems for a low earth orbit space station application are shown in Table I.

The storage subsystems were designed to deliver the initial power level of 37.5 kW for a maximum eclipse period of 35.7 minutes or a total of 22.3 kWh. The LEO cycle times, 35.7 minutes for discharge and 58.8 minutes for charge, correspond to a 270 n mi orbit. The subsystems were configured to provide 37.5 kW, with 12.5 kW on each of three buses and one module per bus. Each subsystem was required to provide full power with one module failed. Thus, the power system was equipped with bus switching capabilities. The subsystems were designed to operate at 120 volts, which is considerably higher than the 28-54 volt systems that have been flown previously. At the high power levels required, high voltage will result in decreased current levels and hence reduced conductor weight throughout the electrical power systems.

Peak power requirements have not as yet been defined. Energy storage subsystems have the capability of delivering peak power above the rated power level and within a required range of voltage regulation. However, since the subsystems and associated wiring must be designed to meet peak demands, various penalties are associated with this capability, including increased storage volumes, decreased lifetimes and increased weight of energy storage and wiring. Due to the lack of peak power design parameters, these aspects have not been considered.

N84-23022

BACKGROUND

The requirements for low earth orbit energy storage subsystems are very demanding. Systems must provide many cycles at high rates of charge and discharge. There is a long lead time involved in the development and qualification of a storage subsystem for aerospace applications. The space station is presently scheduled to be operational by 1992. Nickel-cadmium batteries, nickel-hydrogen batteries and regenerative fuel cells were chosen for this study because they are the only electrochemical storage subsystems that can operate satisfactorily in LEO, whose state of development is such that they could be considered in this time frame.

Nickel-cadmium batteries have almost exclusively provided the eclipse power for space systems. They are proven and dependable. An extensive data base on life and performance is available. However, most battery systems that have flown to date have operated between 28 to 54 volts and ranged from 0.5 to 1 kW. Providing power for a system of 37.5 kW at 120 volts will require a major scale-up effort. Cell size, monitoring and control of individual units, and thermal management are areas that must be addressed if nickel-cadmium batteries are to provide the storage for a system of this magnitude. For this study, standard 50 AH Ni-Cd cells were used in the design of this subsystem because they are widely used and accepted as state of the art technology.

Nickel-hydrogen systems are an attractive alternative to nickel-cadmium batteries. They offer the promise of long life at deeper depths of discharge than conventional nickel-cadmium systems. Although the nickel-hydrogen systems are beginning to be used for geosynchronous orbit (GEO) applications, the projected life and performance of individual pressure vessel (IPV) NiH₂ systems have not yet been demonstrated in LEO. An alternative approach to the NiH₂ cell design involves a bipolar stack in a common pressure vessel. This concept incorporates elements from fuel cell and battery technologies; a bipolar Ni-H₂ stacks consists of individual Ni-H₂ cells stacked between bipolar plates and connected in series, as is common in fuel cells. The major components of the IPV cells are used in the bipolar systems with minor modifications. In addition, the bipolar system is equipped with active cooling and provisions for electrolyte and oxygen management that are more commonly found in fuel cell systems. This

concept offers advantages over individual cell systems in the areas of volumetric and gravimetric energy density and controllability. A bipolar stack would be controlled at the system level rather than at the cell level. The bipolar concept was chosen for this study because it offers many advantages over the IPV batteries for this type of application. Bipolar nickel-hydrogen systems are in the early phases of development; however, since the components from IPV systems can be used directly, the bipolar system is a viable option for space station storage.

The regenerative fuel cell subsystem integrates a fuel cell with an electrolysis unit which is essentially a fuel cell running in reverse. The alkaline system was considered in this study, because it has improved performance, reliability, and life over the acid system. The two have been recently integrated in a breadboard demonstration. The fuel cell uses standard Shuttle-Orbiter hardware and the electrolysis unit is a recent scale-up of a unit used as part of a life support system unit. The RFC has a low round trip electrical efficiency when compared to the battery systems; this must also be considered in the overall design of the power system.

DESIGN AND PERFORMANCE PARAMETERS

The storage systems were studied to determine the design and performance parameters for the 37.5 kW power system storage for the space station. Space station life is estimated at thirty years. No electrochemical storage subsystem has a life even approaching thirty years; therefore, the systems have been designed for long life by limiting the depth of discharge (DOD) or current density with the realization that failures and replacements will occur over the thirty year period. An effort was made to optimize life in order to minimize replacements. Since these subsystems are being considered for application in a manned space station, it has been assumed that ancillaries which may fail before the electrochemical portions of the subsystems will be replaced and thus they will not be considered life-limiting. Performance and the effect of the redundancy requirement were also considered when choosing the DOD or current density at which the system would operate. As electrochemical systems are operated there is a gradual degradation of performance. These subsystems were designed to provide the required power at the end of life (worst case conditions). End of life

is defined as the point where the storage subsystem can no longer deliver the required power within a specific voltage range.

Nickel-cadmium batteries. - The nickel-cadmium subsystem was configured using state-of-the-art 50 AH cells. The subsystem was designed to operate over a range of DOD's from 18 percent to 25 percent. The initial DOD of 18 percent corresponds to the case with all three units operating, while 25 percent DOD corresponds to the case with one module unit failed. Full power is provided by increasing the DOD on the remaining two modules. Life, performance, and response to increased depths of discharge were factored into the initial decision of the operating depth. In order to minimize the number of cells series string, the end-of-life voltage was defined to be 1.1 volts/cell. Below this value the voltage falls rapidly and there is little usable capacity. The Ni-Cd subsystem was designed to operate at 10° C based on life and heat rejection requirements.

Bipolar nickel-hydrogen batteries. - The bipolar nickel-hydrogen energy storage subsystem is in the early stages of development. As such, standard hardware does not presently exist. The choice of dimensions, stack configuration, cell capacities and materials was not constrained but was based on current concepts. As the technology matures, standard hardware and cell configurations will become available. For this study, the Ni-H₂ system was configured using 125 AH cells with an active area of .403 m². The depth of discharge for the bipolar Ni-H₂ storage subsystem ranges between 50 percent DOD with all three units operating and 75 percent DOD with one unit failed. Based on current projections this range can reasonably be handled by the bipolar system and still yield long life. As with the Ni-Cd storage subsystem, the end of life was defined at the point where the average cell voltage degrades to 1.1 volts power cell at the end of discharge. An operating temperature of 30° C was chosen based upon performance and heat rejection requirements.

Regenerative fuel cell. - The regenerative fuel cell subsystem was designed to operate at relatively low current densities in order to improve overall round-trip electrical efficiency and extend life. The fuel cell and electrolyzer units were designed to operate at 9.3 to 13.9 ASM and 13.9 to 20.9 ASM, respectively. The range in current densities represents the increase that

occurs with the failure of one module set. If one module set fails, the current density of the remaining fuel cell and electrolysis modules will increase by 50 percent. Neither of the resulting current densities is unreasonably high, and would have minor impacts on life and efficiency. The end-of-life voltages were determined to be 0.94 volts for the fuel cell and 1.53 volts for the electrolysis unit. The end-of-life voltage was derived from performance curves under the chosen operating conditions assuming degradation rates of less than 1 μV/hr for both the fuel cell and electrolysis unit. It is more likely that the system will go out of regulation on the discharge portion of the cycle than during the charge portion. Therefore, the fuel cell will limit the life of the subsystem.

Operating temperature for a RFC ranges from 60° to 93.3° C for both units. The units were designed to operate at 65.6° C. The choice of operating temperatures at the low end of the range should result in increased life. The operating pressures of 4.13x10⁵ pascals for the fuel cell and 2.41x10⁶ pascals for the electrolysis unit were chosen to increase performance and improve volumetric energy density.

The active area of the fuel cell is that of the current Shuttle-Orbiter technology, 4.6x10⁻² m² while the active area of the electrolyzer is 9.3x10⁻³ m².

SUBSYSTEM CONFIGURATIONS

Performance parameters were established for each system at the defined operating levels. The storage subsystems were configured based on the established design and performance parameters.

Nickel-cadmium subsystem configuration. - The Ni-Cd storage subsystem designed to meet the specified design and performance parameters consists of three modules, each consisting of seven, 109 cell batteries (fig. 1). The 109 cells are required to provide 120 volts at the end of life. In order to supply the required current at the chosen DOD, 7 parallel battery strings are required. This translates to a total of 2289 cells per module, each of which would require electronics for individual monitoring and control in an autonomous system. Nickel-cadmium batteries require a high degree of control because hydrogen gas is generated on cell reversal. As there is no mechanism to recombine hydrogen gas generated in a Ni-Cd cell, excessive gas pressure, which can lead to rupture of the cell

case, can result. Cells in a series string can become unbalanced, thus the weaker cells in the string could be reversed while the string voltage remains within limits.

The total subsystem weight for the Ni-Cd storage subsystem is 5618 kg. Included in this value are the weights of the cells, the packaging hardware, and cell interconnects. Power conditioning, cooling, and monitoring equipment have not been included. The subsystem volume 1.61 m^3 , accounts for the same hardware included in the subsystem weight. No packaging factors to account for unusable space have been included.

Bipolar nickel-hydrogen batteries. - The specified design requirements for the bipolar Ni-H₂ subsystem result in a system with 1 battery on each of three buses. Each battery is comprised of a stack of 109 cells housed in a cylindrical pressure vessel with torispherical end caps, as shown in Fig. 2. The number of cells is dictated by the end of life, end of discharge voltage. Gases generated on overcharge and overdischarge are recombined, eliminating the need for individual cell monitoring and control as there is no danger of excessive pressure generation (no damage from cell reversal in Ni/H₂ cells). Thus, the total number of units requiring monitoring and control is only 3.

The total subsystem weight of 1603 kg includes battery weight, associated hardware, and active cooling internal to the subsystem. Power conditioning, heat exchangers, cooling external to the subsystem and equipment for monitoring and control have not been considered. As with the Ni-Cd batteries, the subsystem volume of 1.78 m^3 includes the above hardware only, no attempts have been made to account for spatial arrangements or unusable space.

Regenerative fuel cell subsystem configuration. - The chosen design and performance parameters for the regenerative fuel cell subsystem result in the configuration shown in Fig. 3, with 2 fuel cell stacks and 1 electrolysis stack per 12.5 kW module. The fuel cell output voltage of 123 volts results from 2 fuel cell stacks, of 132 cells each, connected electrically in parallel. The electrolyzer input voltage of 84 volts is derived from 1 electrolysis stack of 55 cells. The total number of controllable units for a 37.5 kW subsystem is 6 fuel cell stacks and 3 electrolysis stacks. The RFC configuration is summarized in

Table II. The tank weight was determined for cylindrical, Inconel storage tanks with a safety factor of 1.5. The total tank volume was calculated based on an excess of gaseous reactants to allow cycling between tank pressures of 2.07×10^6 pascals and 4.82×10^5 pascals. The same restrictions for total weights and volumes that applied to the battery subsystems apply here.

SUBSYSTEM CHARACTERISTICS

The characteristics for each of the subsystems designed to the specified requirements, with the stated performance parameters and configurations are summarized. The effective energy density refers to the energy density of the subsystems as configured for this specific application.

Nickel-cadmium subsystem characteristics. - The resulting Ni-Cd storage subsystem has an effective energy density of 3.9 Wh/kg. The round trip electrical efficiency of the subsystem is approximately 70 percent. This is based on end of life performance, and thus, accounts for the degradation in voltage performance and capacity that occurs with aging. The projected life for the nickel-cadmium subsystem operating at the specified conditions is 6 years. The Ni-Cd subsystem will most likely fail due to a gradual degradation of voltage and capacity which results in the battery being unable to provide the required power within the desired limits. The maximum heat rejection requirements, 12.9 kW, have been calculated for the worst case -- end-of-life, end of discharge performance. Heat is rejected at 10° C .

Nickel-hydrogen subsystem characteristics. - The bipolar Ni-H₂ subsystem configured to the above parameters has an effective energy density of 13.9 Wh/kg. The round-trip electrical efficiency based on end-of-life watt-hour performance is approximately 70 percent. Parasitic losses of ancillary hardware have not been considered (pumps for coolant circulation). The subsystem has a projected life of 4 years based on current models for IPV cell performance modified by bipolar performance data. The batteries will most likely fail due to electrochemical degradation of cell voltages and capacities. The subsystem is configured to sustain individual cell failures and still meet power requirements. The maximum heat rejection requirements of 15.0 kW are based on worst case performance. Heat is rejected at the cell operating temperature of 30° C .

Regenerative fuel cell subsystem characteristics. - The regenerative fuel cell subsystem configured for this specific point design has an effective energy density of 17.1 Wh/kg. The round-trip electrical efficiency was 58.8 percent. This does not account for any parasitic pump losses of the ancillary hardware. The projected life was obtained from a time dependent model developed for Shuttle-Orbiter qualification tests. Electrolysis life data is limited. However, life is projected to be greater than or equal to that of the fuel cell. As with the battery systems, the most likely failure mode is electrochemical degradation. This is the life limiting failure that the model predicts. However, since the reactants of the RFC are not stored in the electrodes, the degradation occurs at a much lower rate than in the battery systems. The maximum heat rejection requirements are 21.6 kW, based on the maximum difference in cell operating voltages and the thermoneutral voltage of the cell reaction.

Subsystem Comparison. - The design results are summarized in Table III and indicate that the bipolar NiH₂ and RFC subsystems offer advantages over the Ni-Cd subsystem primarily in the areas of energy density and controllability. The effective energy density of the Ni-Cd subsystem was 3.9 Wh/kg compared to 13.9 Wh/kg and 17.1 Wh/kg for the bipolar Ni-H₂ and RFC sub-

systems, respectively. For a nickel-cadmium subsystem to be totally autonomous, each of the 2289 cells in the batteries would require circuitry for monitoring and control. This number is reduced to 3 in the case of the bipolar Ni-H₂ subsystem and 9 in the case of the RFC subsystem (6 fuel cells and 3 electrolyzers). The advanced technologies are less complex to control and can be more readily integrated into a power system.

CONCLUDING REMARKS

A study of this type is useful for systematically comparing the differences between energy storage options. It should be stressed that the subsystem parameters generated in this study are based on the design requirements for a specific configuration, and as such, may not be extrapolated to apply to other subsystem configurations. The storage subsystem is only part of the overall power system and the relationship of the energy storage subsystem to the overall power system must be considered. Many other considerations, including life cycle costs and integration with other systems, could also be taken into account.

The life and performance estimates in this design represent those available from state-of-the-art technology. These designs do not account for any technology advances which could extend life or improve performance in the future.



TABLE I. - 37.5 kW POINT DESIGN COMPARISON OF
 NICKEL-CADMIUM, BIPOLAR NICKEL-HYDROGEN,
 AND REGENERATIVE FUEL CELL ENERGY
 STORAGE SUBSYSTEMS

	Design requirements
Power:	Average - 37.5 kW Peak - TBD Emergency - separate system
Configuration:	3 modules designed to deliver 12.5 kW each 1 module on each of 3 buses 2 modules able to deliver full power
Voltage:	120 V
Orbit:	Nominal - 270 n mi Range - 200 to 300 n mi
Time:	Charge - 58.8 min. Discharge - 35.7 min.

TABLE II. - REGENERATIVE FUEL CELL SUBSYSTEM
 CONFIGURATION

[1 Module on each of 3 buses]

	Fuel cell	Electrolyzer
Power:		
Stacks/module	2	1
Cells/stack	132	55
Number of controllable units	6 stacks	3 stacks
Total stack weight	620 kg	393 kg
Storage:		
Total reactant weight	10.05 kg H ₂ O	
Total tank weight	45.5 kg H ₂ 22.7 kg O ₂	
Total tank volume	0.65 m ³ H ₂ 0.33 m ³ O ₂ 0.008 m ³ H ₂ O	
Total RFC subsystem weight	1305 kg	
Total RFC subsystem volume	2.92 m ³	

TABLE III. - 37.5 kW POINT DESIGN COMPARISON OF THE
 NICKEL-CADMIUM BATTERY, BIPOLAR NICKEL-HYDROGEN
 BATTERY, AND REGENERATIVE FUEL CELL ENERGY
 STORAGE SUBSYSTEMS

Characteristic	Bipolar		
	Ni-Cd	Ni-H ₂	RFC
Effective energy density, W-hr/kg	3.9	13.9	17.1
Round-trip electrical efficiency, %	70	70	58.8
Total storage subsystem weight, kg	5618	1603	1305
Total storage subsystem volume, m ³	1.61	1.78	2.92
Required storage subsystem replacements for 30 year life	5-6	6-7	6
Heat rejection: Requirement, kW	12.9	15	21.9
Temperature, °C	10	30	66
Number of controllable units	2289	3	6 FC 3 E

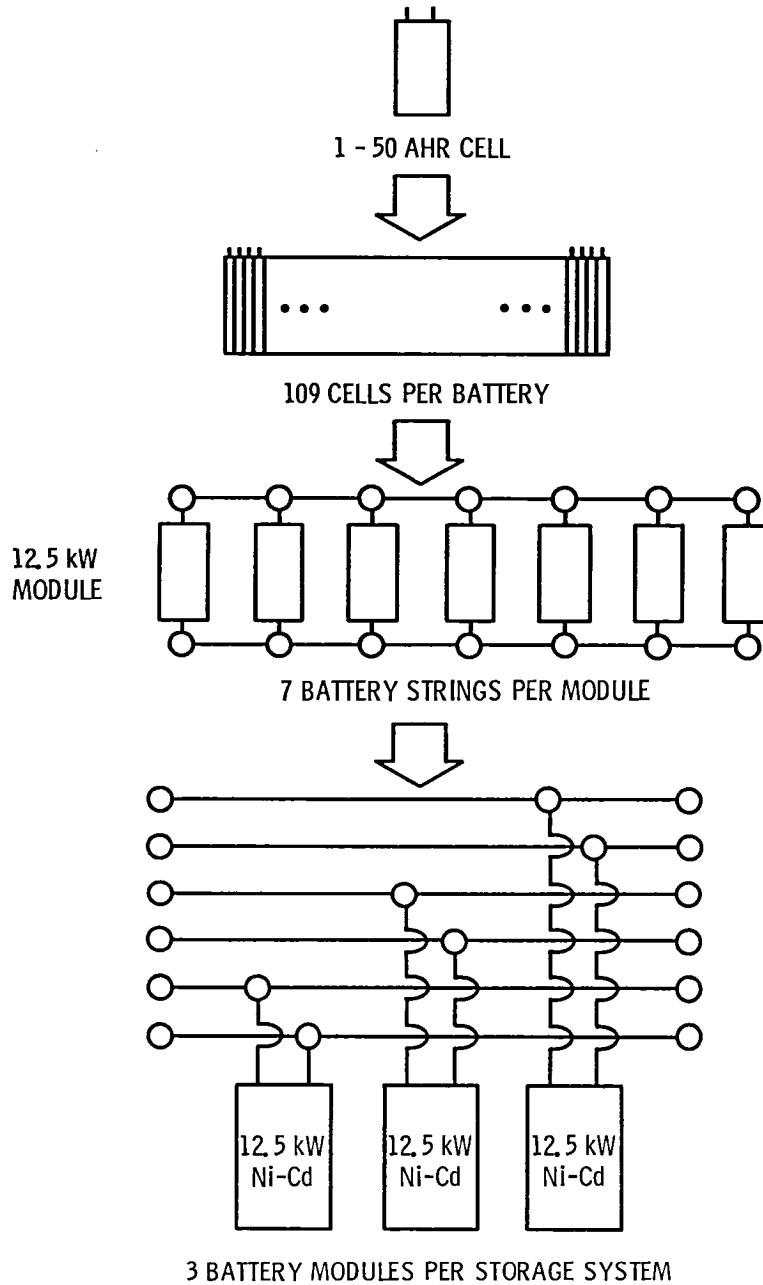
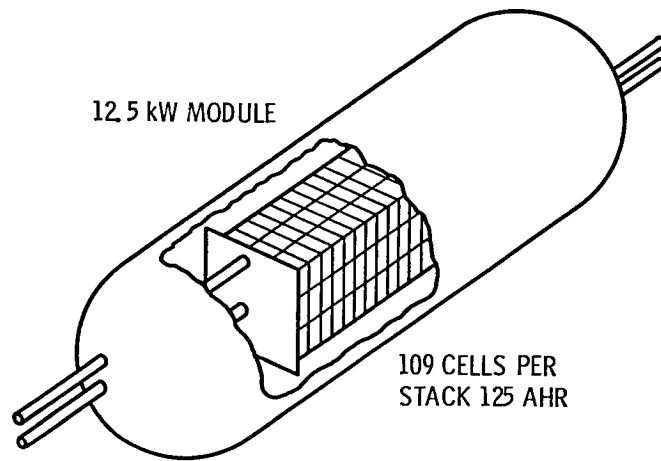
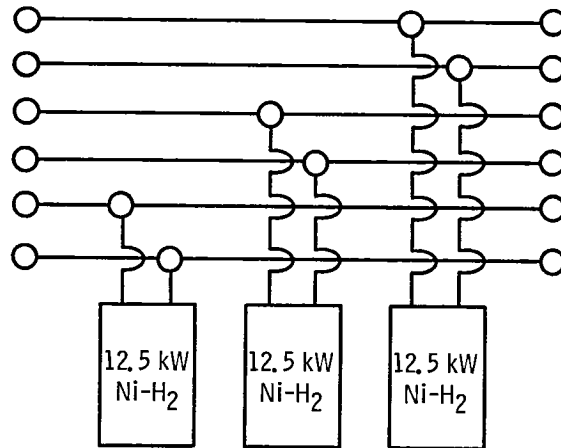

Figure 1. - 37.5 kW Ni-Cd energy storage system.



1 STACK AND PRESSURE VESSEL PER MODULE



3 BATTERY MODULES PER STORAGE SYSTEM

Figure 2. - 37.5 kW Bipolar Ni-H₂ energy storage system.

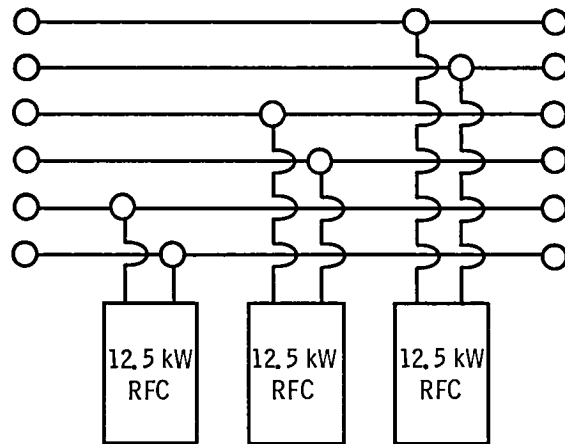
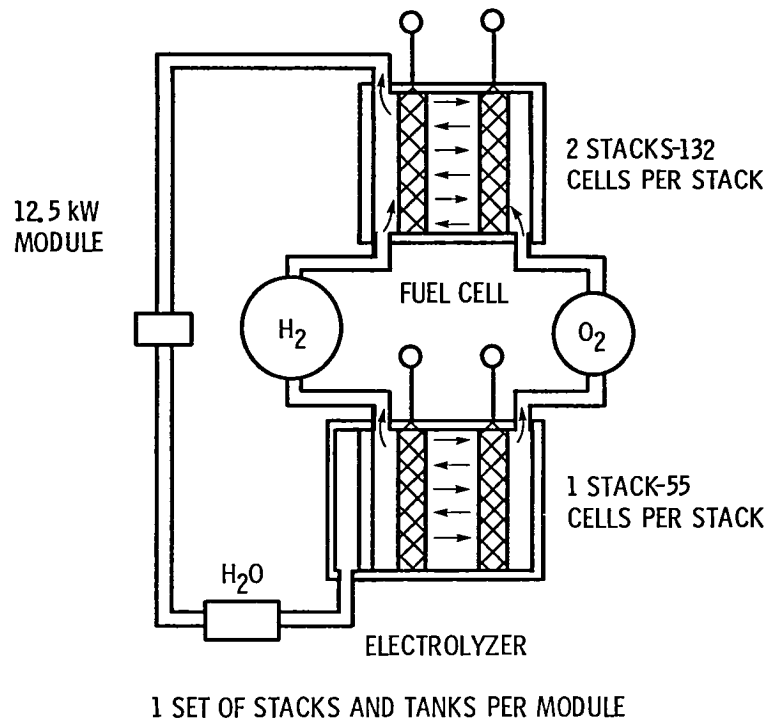

3 RFC MODULES PER STORAGE SYSTEM

Figure 3. - 37.5 kW RFC energy storage system.

1. Report No. NASA TM-83651		2. Government Accession No.		3. Recipient's Catalog No.	
4. Title and Subtitle A 37.5-kW Point Design Comparison of the Nickel-Cadmium Battery, Bipolar Nickel-Hydrogen Battery, and Regenerative Hydrogen-Oxygen Fuel Cell Energy Storage Subsystems for Low Earth Orbit				5. Report Date	
				6. Performing Organization Code 506-55-52	
7. Author(s) Michelle A. Manzo and Mark A. Hoberecht				8. Performing Organization Report No. E-2016	
				10. Work Unit No.	
9. Performing Organization Name and Address National Aeronautics and Space Administration Lewis Research Center Cleveland, Ohio 44135				11. Contract or Grant No.	
				13. Type of Report and Period Covered Technical Memorandum	
12. Sponsoring Agency Name and Address National Aeronautics and Space Administration Washington, D.C. 20546				14. Sponsoring Agency Code	
15. Supplementary Notes Prepared for the Nineteenth Intersociety Energy Conversion Engineering Conference cosponsored by the ANS, ASME, SAE, IEEE, AIAA, ACS, and AIChE, San Francisco, California, August 19-24, 1984.					
16. Abstract Nickel-cadmium batteries, bipolar nickel-hydrogen batteries, and regenerative fuel cell storage subsystems were evaluated for use as the storage subsystem in a 37.5 kW power system for space station. Design requirements were set in order to establish a common baseline for comparison purposes. The storage subsystems were compared on the basis of effective energy density, round trip electrical efficiency, total subsystem weight and volume, and life.					
17. Key Words (Suggested by Author(s)) Nickel cadmium batteries; Bipolar nickel-hydrogen batteries; Regenerative fuel cells; Space station			18. Distribution Statement Unclassified - unlimited STAR Category 44		
19. Security Classif. (of this report) Unclassified		20. Security Classif. (of this page) Unclassified		21. No. of pages	22. Price*

22

National Aeronautics and
Space Administration

Washington, D.C.
20546

Official Business
Penalty for Private Use, \$300

SPECIAL FOURTH CLASS MAIL
BOOK

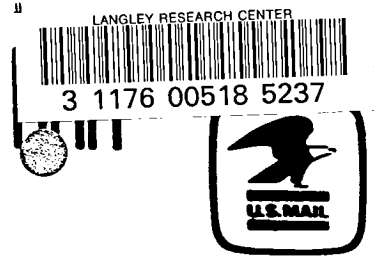

Postage and Fees Paid
National Aeronautics and
Space Administration
NASA-451

NASA

POSTMASTER: If Undeliverable (Section 15K
Postal Manual) Do Not Return
