

## General Disclaimer

### One or more of the Following Statements may affect this Document

- This document has been reproduced from the best copy furnished by the organizational source. It is being released in the interest of making available as much information as possible.
- This document may contain data, which exceeds the sheet parameters. It was furnished in this condition by the organizational source and is the best copy available.
- This document may contain tone-on-tone or color graphs, charts and/or pictures, which have been reproduced in black and white.
- This document is paginated as submitted by the original source.
- Portions of this document are not fully legible due to the historical nature of some of the material. However, it is the best reproduction available from the original submission.

DRA



# COLLEGE OF ENGINEERING

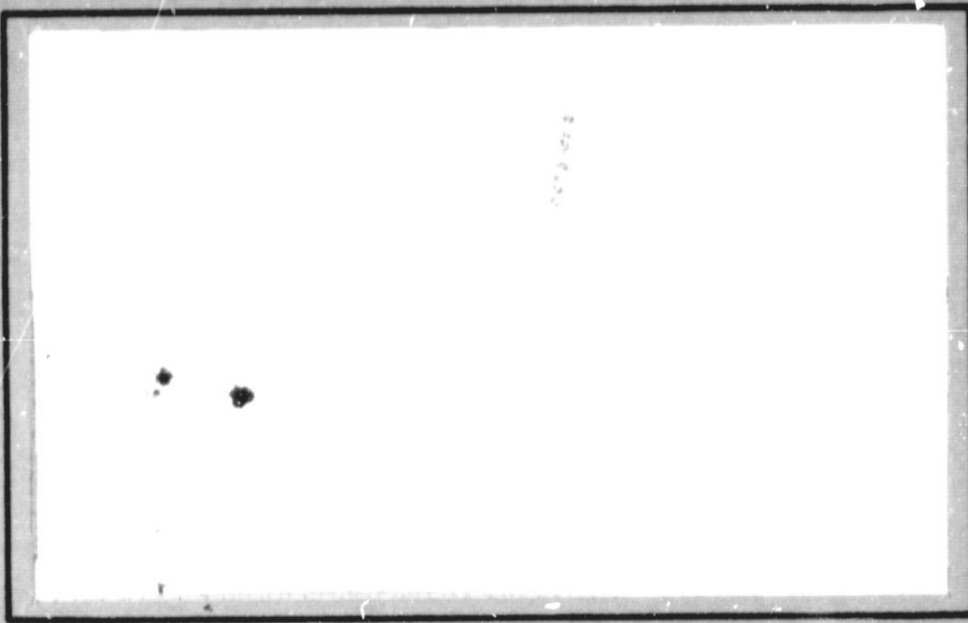

# VIRGINIA POLYTECHNIC INSTITUTE AND STATE UNIVERSITY



**BLACKSBURG,  
VIRGINIA**

(NASA-CR-173507) CLFE2D: A GENERALIZED PLANE STRAIN FINITE ELEMENT PROGRAM  
LAMINATED COMPOSITES SUBJECT TO MECHANICAL AND HYGROTHERMAL LOADING Interim Report  
(Virginia Polytechnic Inst. and State Univ.) G3/39

N84-23921  
Unclass  
13273

College of Engineering  
Virginia Polytechnic Institute and State University  
Blacksburg, VA 24061

VPI-E-83-40

October, 1983

CLFE2D - A Generalized Plane Strain Finite  
Element Program for Laminated Composites Subjected  
to Mechanical and Hygrothermal Loading

Matthew B. Buczek<sup>1</sup>

Michael A. Gregory<sup>2</sup>

Carl T. Herakovich<sup>3</sup>

Department of Engineering Science & Mechanics

Interim Report 38  
The NASA-Virginia Tech Composites Program

NASA Cooperative Agreement NCC1-15

Prepared for: Applied Materials Branch  
National Aeronautics & Space Administration  
Langley Research Center  
Hampton, VA 23665

<sup>1</sup>Engineer, Atlantic Research Corporation

<sup>2</sup>Graduate Student

<sup>3</sup>Professor of Engineering Science & Mechanics

<b>BIBLIOGRAPHIC DATA SHEET</b>		1. Report No. VPI-E-83-40	2.	3. Recipient's Accession No.
4. Title and Subtitle CLFE2D - A GENERALIZED PLANE STRAIN FINITE ELEMENT PROGRAM FOR LAMINATED COMPOSITES SUBJECTED TO MECHANICAL AND HYGROTHERMAL LOADING			5. Report Date October 1983	6.
7. Author(s) M. B. Buczek, M. A. Gregory, and C. T. Herakovich			8. Performing Organization Rept. No. VPI-E-83-40	
9. Performing Organization Name and Address Virginia Polytechnic Institute & State University Engineering Science & Mechanics Blacksburg, Virginia 24061			10. Project/Task/Work Unit No.	11. Contract/Grant No. CA NCC1-15
12. Sponsoring Organization Name and Address National Aeronautics & Space Administration Langley Research Center Hampton, Virginia 23665			13. Type of Report & Period Covered	
15. Supplementary Notes			14.	
16. Abstracts				
<p>CLFE2D is a two dimensional generalized plane strain finite element code. It uses a linear, four node, general quadrilateral, isoparametric element.</p> <p>The program was developed to calculate the displacements, strains, stresses, and strain energy densities in a finite width composite laminate. CLFE2D offers any combination of the following load types: nodal displacements, nodal forces, uniform normal strain, or hygrothermal.</p> <p>The program allows the user to input one set of three dimensional orthotropic material properties. The user can then specify the angle of material principal orientation for each element in the mesh.</p> <p>Output includes displacements, stresses, strains and strain energy densities at points selected by the user. An option is also available to plot the undeformed and deformed finite element meshes.</p>				
17. Key Words and Document Analysis. 17a. Descriptors				
finite element, laminated composites, generalized plane strain				
17b. Identifiers/Open-Ended Terms				
17c. COSATI Field/Group				
18. Availability Statement Distribution Unlimited		19. Security Class (This Report) UNCLASSIFIED	21. No. of Pages 35	
		20. Security Class (This Page)	22. Price	

## ACKNOWLEDGEMENTS

CLFE2D was written by Mr. Buczek. The User's Guide was written by Mr. Gregory. Professor Herakovich was the faculty advisor on the project. Primary financial support was provided by the NASA-Virginia Tech Composites Program; additional support was provided by Hercules Incorporated.

Special thanks is given to Professor J. N. Reddy for assistance with development of CLFE2D and for the use of subroutines BNDRY and SOLVE which are used to apply the boundary conditions and solve the system of simultaneous equations.

## 1.0 Introduction:

CLFE2D was developed under the assumption of a state of generalized plane strain. The most general displacement field for such problems can be written

$$u_{\text{total}} = U(y,z) + \epsilon_x^0 x \quad (1a)$$

$$v = V(y,z) \quad (1b)$$

$$w = W(y,z) \quad (1c)$$

The assumption of generalized plane strain allows the user to study the response of an infinitely long body of arbitrary cross-section to various loadings with the restriction that all quantities except axial displacement are independent of the axial coordinate  $x$ . The coordinate system used by CLFE2D is shown in Fig. (1.1). The  $x$ ,  $y$  and  $z$  axes represent the global coordinate system while the material principal directions are represented by the 1, 2 and 3 axes. The region of interest to be modeled by finite elements is then a typical cross section (or a symmetric portion of it).

The element used in CLFE2D is a four node, linear, general quadrilateral, isoparametric element. A three node version of the element can be obtained by "double-numbering" the first local node in the element connectivity data. The available element geometries are shown in Fig. (1.2). CLFE2D requires that the local node numbering scheme, for a given element, proceed in a counter-clockwise direction.

An in-depth description of the finite element used in this program can be found in reference [1]. The finite element formulation for the generalized plane strain problem can be found in reference [2].

In addition to the above overview of the program capabilities, this report presents the input requirements, the output capabilities, details

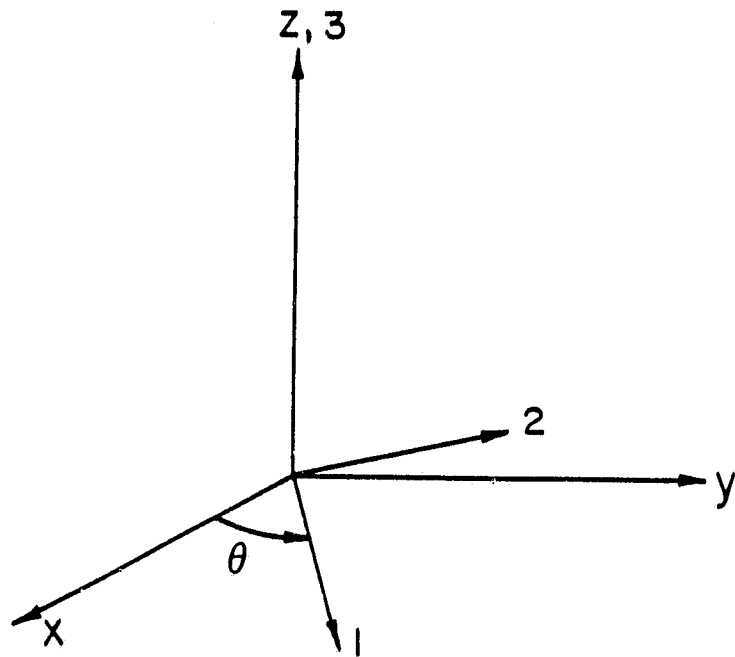

Fig. 1.1 The Coordinate Systems of CLFE2D

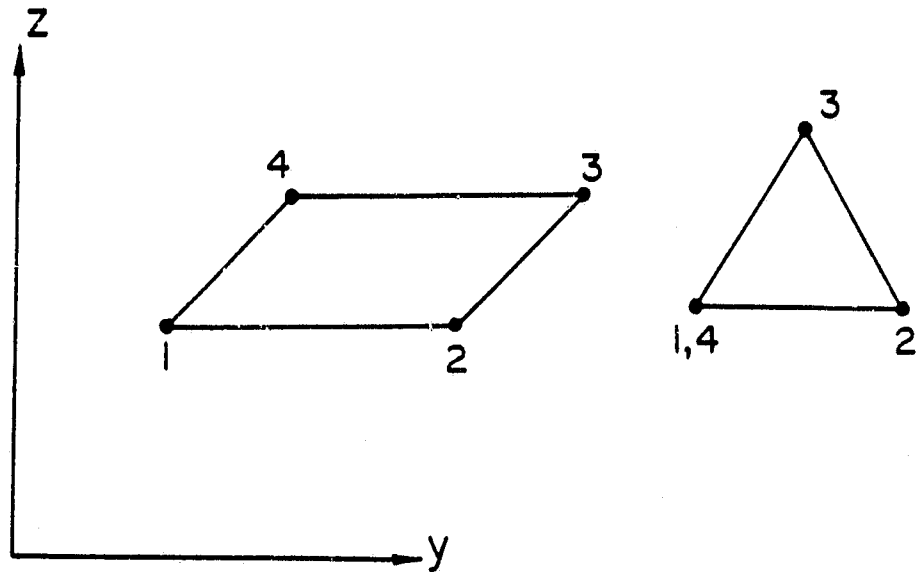

Fig. 1.2 Available Element Geometries

of the input card sequence, a note on symmetry requirements and an example problem.

## 2.0 CLFE2D Input Requirements:

In this section a description of each type of card image in the input file is given. The required format of each card image is given in section 3.0.

### Type 1 Title (Cards 1 & 2)

The title consists of two 80 character lines which will be printed on the output file.

### Type 2 Master control Information (Card 3)

On this card the user specifies the number of elements and nodes in the mesh, the number of different angles of material principal orientation, the number of specified nodal degrees of freedom and forces. The user also specifies the desired plot option and a data check option on this card (see section 3.0). The data check option permits the user to check the input without proceeding to the solution.

### Type 3 Nodal Coordinate Scale Factors (Card 4)

To ease input the user can specify scale factors which independently scale the magnitude of the Y and Z nodal coordinate values.

### Type 4 Printer Control Keys (Card 5)

On this card the user sets the various output keys (see section 3.0) which allow for the generation of a tailored output file.

### Type 5 Plotter Control Information (Card 6)

On this card the user specifies the plotter scale factors (see



Output Capabilities). Card 6 can be omitted if output plots are not desired.

Type 6 Material Property Information (Card 7 and 8)

On these two cards the user inputs one set of three dimensional orthotropic material properties. These properties must include thermal or hygroscopic expansion coefficients if the response to hygrothermal loading is desired.

Type 7 Material Property Orientation Information (Card 9)

The user inputs an angle number and magnitude (degrees) for each different material property orientation in the laminate.

Type 8 Element Data Information (Card 10)

The element connectivity data, material property orientation angle number, and the output points (see section 3.0) for each element are specified on this card. Card 10 is repeated NEM times, where NEM is the number of elements in the mesh.

Type 9 Nodal Data Information (Card 11)

The nodal coordinates are specified on this card. The nodal coordinate values must be greater than or equal to zero. Card 11 is repeated NODS times, where NODS is the number of nodes in the mesh.

Type 10 Specified Nodal Displacement Information (Card 12)

On this card the user identifies the node number and displacement of each constrained degree of freedom. Card 12 is repeated for each degree of freedom that has a specified displacement. If there are no constrained degrees of freedom, Card 12 is omitted from the input file.

Type 11 Specified Nodal Force Information (Card 13)

On this card the user identifies the node number and the component magnitude of each of the specified nodal forces. Card 13 is repeated for each component of the specified nodal forces. If there are no specified nodal forces, Card 13 is omitted from the input file.

Type 12 Normal Strain and Hygrothermal Load Information (Card 14)

Here the user specifies the applied normal strain  $\epsilon_x^0$  along with the temperature or moisture change. It is possible to specify these values as zero.

### 3.0 CLFE2D Output Capabilities:

CLFE2D solves for the nodal displacements, strains, stresses and strain energy densities for each element in the mesh. These values are calculated in the global (x, y, z) coordinate system. For a given element, the values of strain, stress and strain energy density are calculated at a combination of any nine output points. These output points are specified for each element on Card 10 of the input file. Figure (1.3) illustrates the location of these output points on a given element. Output point 5 is the only valid output point for a triangular element. Specifying other values for triangular elements can cause errors.

It should be noted that the strains, stresses, and strain energies that are printed are the response to the combined mechanical and Hygrothermal loadings. The u displacement that is printed is the U(y,z) of eqn. (1a). To obtain the total u displacement at a desired x location, one must take into account the applied normal strain  $\epsilon_x^0$ .

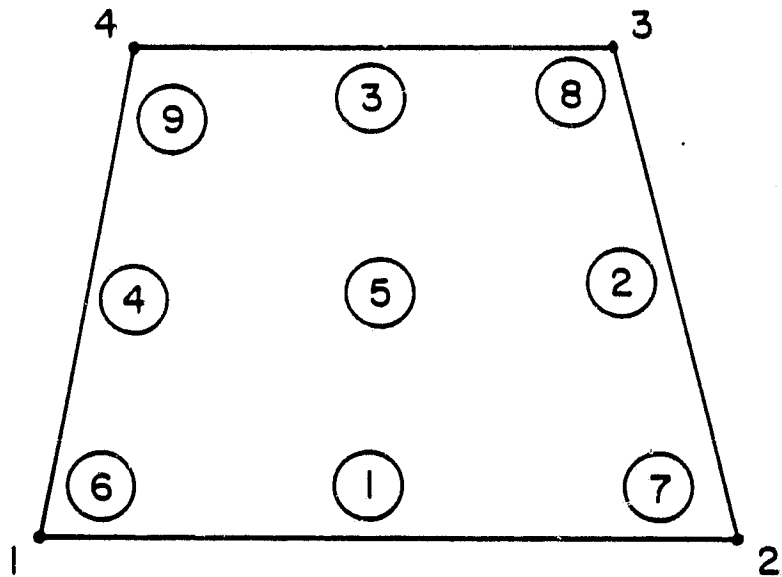

• Element local node number

Ⓝ Location of output point n

Fig. 1.3 Element Stress-Strain Output Points

In CLFE2D the user has the ability to tailor the output file. By setting various printer control keys on Card 5 of the input file, he can opt to have all or any of the following printed:

Key (1)	Element Data
Key (2)	Nodal Data
Key (3)	Specified Nodal Displacements
Key (4)	Specified Nodal Forces
Key (5)	Displacements
Key (6)	Strains, Stresses and Strain Energy Densities

The user can also opt to plot the undeformed and deformed meshes by selecting the appropriate plot option on Card 3. The user controls the scale of these plots by specifying various plot scale factors on Card 6. The various plot options and scale factors are described in detail in the following outline.

1. Plot Option NPLOT (Card 3)

NPLOT is one of the variables which is user specified on Card 3.

The user determines which plots will be printed by setting NPLOT to any of the following values.

0 = No plots

1 = Undeformed plot only

2 = Deformed plot only

3 = Both undeformed and deformed plots

2. Plotter Control Information (Card 6)

On Card 6 of the input file, the user specifies the following plot scale factors:

(a) PYSCL = Plot Y-direction scale factor

This variable determines the maximum length of the plot in the Y-direction. PYSCL must be chosen such that the maximum Y-coordinate in the mesh will be scaled to a value less than or equal to 18 inches.

(b) PZSCL = Plot Z-direction scale factor

This variable determines the maximum length of the plot in the Z-direction. PZSCL must be chosen such that the maximum Z-coordinate in the mesh will be scaled to a value less than or equal to 9 inches.

(c) VMAX = Maximum allowable v-displacement

This variable determines the size of the maximum v-displacement in inches. All of the smaller v-displacements are scaled proportionally to this value.

(d) WMAX = Maximum allowable w-displacement

This variable determines the size of the maximum w-displacement in inches. All of the smaller w-displacements are scaled proportionally to this value.

## 4.0 CLFE2D Input Card Sequence

<u>Cards 1 &amp; 2 (20A4)</u>		<u>Title Cards</u>
<u>Column</u>		<u>Contents</u>
1-80		Title
 <u>Card 3 (16I5)</u>		<u>Master Control Card</u>
<u>Column</u>		<u>Contents</u>
1-5	NEM	Number of Elements
6-10	NODS	Number of Node Points
11-15	NANG	Number of Different Angles
16-20	NSDF	Number of Specified Nodal Displacements
21-25	NSBF	Number of Specified Nodal Forces
26-30	NPLOT	Plot Option
	= 0 none	
	= 1 undeformed plot only	
	= 2 deformed plot only	
	= 3 both undeformed and deformed	
41-45	NCHECK	Data Check Option

By setting NPLOT .EQ.1 and NCHECK .NE.0 a data check and an undeformed plot will be generated. To obtain the complete solution, another run must be made with NCHECK .EQ.0.

<u>Card 4 (8D10.5)</u>		<u>Scale Factors</u>
<u>Column</u>		<u>Contents</u>
1-10	SCAY	Y-Nodal Coordinate Scale Factor
11-20	SCAZ	Z-Nodal Coordinate Scale Factor

<u>Card 5 (16I5)</u>		<u>Printer Control Card</u>
<u>Column</u>		<u>Contents</u>
1-5	KEY(1)	Key for Printing Element Data
6-10	KEY(2)	Key for Printing Nodal Data
11-15	KEY(3)	Key for Printing Specified Nodal Displacements
16-20	KEY(4)	Key for Printing Specified Nodal Forces
21-25	KEY(5)	Key for Printing Displacements
26-30	KEY(6)	Key for Printing Strains, Stresses and Strain Energies Per Unit Volume

(if KEY(i) .NE. 0 - Print)

(NPLOT .EQ. 0 skip Card 6 and go to Card 7)

<u>Card 6 (8E10.5)</u>		<u>Plotter Control Card</u>
<u>Column</u>		<u>Contents</u>
1-10	PYSCL	Plot Y-Scale Factor
11-20	PZSCL	Plot Z-Scale Factor
21-30	VMAX	Maximum Allowable V-Displacement
31-40	WMAX	Maximum Allowable W-Displacement

Card 7 (8D10.5)Column

1-10 PROP(1)  
11-20 PROP(2)  
21-30 PROP(3)  
31-40 PROP(4)  
41-50 PROP(5)  
51-60 PROP(6)

## Material Properties Card A

Contents

E-11  
E-22  
E-33  
G-23  
G-13  
G-12

Card 8 (8D10.5)Column

1-10 Prop(7)  
11-20 Prop(8)  
21-30 Prop(9)  
31-40 Prop(10)  
41-50 Prop(11)  
51-60 Prop(12)

## Material Properties Card B

Contents

NU-23  
NU-13  
NU-12  
Alpha-11  
Alpha-22  
Alpha-33

Card 9 (8D10.5)Column

1-10 Ang(1)  
11-20 Ang(2)  
.  
.  
.  
.  
Ang(NANG)

## Angle Data Card

Contents

Angle No. 1 (in Degrees)  
Angle No. 2 (in Degrees)  
.  
.  
.  
.  
Angle No. NANG (in Degrees)

Card 10 (5X,6I5)Column

1-5 Blank  
6-10 NOD(N,1)  
11-15 NOD(N,2)  
16-20 NOD(N,3)  
21-25 NOD(N,4)  
26-30 IANG(N)  
31-35 ISTRS(N,1)  
.  
.  
.  
.  
.  
.  
.  
.  
.  
.  
.  
.  
36-40 ISTRS(N,2)  
41-45 ISTRS(N,3)  
.  
.  
.

## Element Data Card(s)

Contents

(Element Numbers may be inserted for Reference)  
Node #1 of Element N  
Node #2 of Element N  
Node #3 of Element N  
Node #4 of Element N  
Angle Number of Element N  
Stress and Strain Output Code for Element N.  
= 0 - None  
= 1 - Side 1  
= 2 - Side 2  
= 3 - Side 3  
= 4 - Side 4  
= 5 - Center  
= 6 - "Node 1"  
= 7 - "Node 2"  
= 8 - "Node 3"  
= 9 - "Node 4"

71-75 ISTRS(N,9)  
\*Repeat Card 10 NEM Times

<u>Card 11</u> (5X,2D10.5)	Nodal Data Card(s)	
<u>Column</u>	<u>Contents</u>	
1-5	Blank	(Node Numbers may be inserted for Reference)
6-15	Y(N)	Y-Coordinate of Node N (This value must be > zero)
16-25	Z(N)	Z-Coordinate of Node N (This value must be > zero)

\*Repeat Card 11 NODS Times #

# If NSDF .EQ. 0 - Skip Card 12 and Go on to Card 13

<u>Card 12</u> (2I5,D10.5)	Specified Nodal Degree of Freedom Card(s)	
<u>Column</u>	<u>Contents</u>	
1-5	ND	Node Number of Specified D.O.F.
6-10	IDR	Direction of Specified D.O.F. (1 = u, 2 = v, and 3 = w)
11-20	VBDF(N)	Specified Displacement Value

\*Repeat Card 12 NSDF Times

\* If NSBF .EQ. 0 - Skip Card 13 and Go on to Card 14

<u>Card 13</u> (2I5,D10.5)	Specified Nodal Force Card(s)	
<u>Column</u>	<u>Contents</u>	
1-5	ND	Node Number of Specified Force
6-10	IDR	Direction of Specified Force (1 = u, 2 = v, 3 = w)
11-20	VBSF(N)	Specified Boundary Force Value

\*Repeat Card 13 NSBF Times

<u>Card 14</u> (8D10.5)	Normal Strain and Hygrothermal Load Card	
<u>Column</u>	<u>Contents</u>	
1-10	EPSX	Applied Normal, (X-Direction), Strain
11-20	TEMP	Temperature Change or Moisture Concentration

-End-



## 5.0 A Note on Symmetry Requirements

To reduce the cost of a finite element stress analysis symmetry arguments are often used when building the finite element mesh. To determine the response of a thin composite laminate tensile specimen the analyst need only model one quarter of the specimen cross-section. To obtain valid results, however, the appropriate symmetry boundary conditions must be specified. These boundary conditions are shown in Fig. (1.4). Along the z-axis ( $y=0$ ) the U and V nodal displacements must be specified to be zero. Similarly, along the y-axis ( $z=0$ ) the W displacements must be set equal to zero.

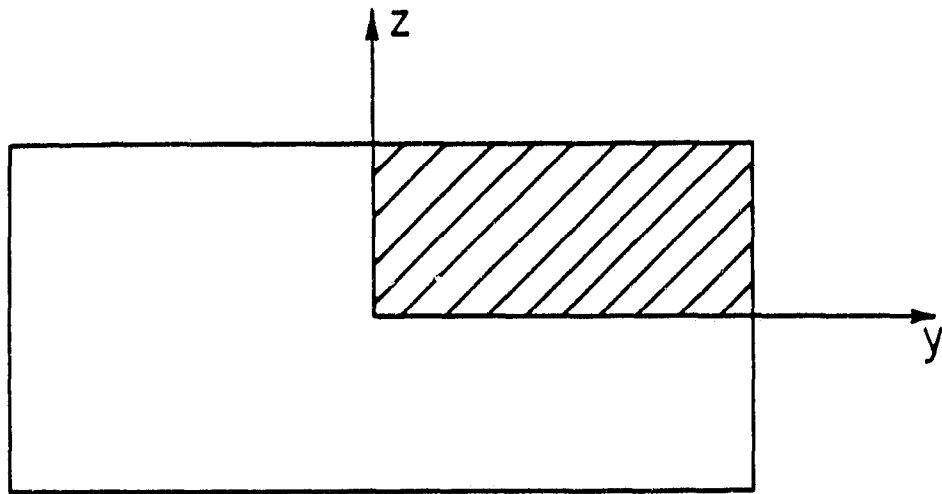

The upper right quadrant of the specimen cross-section will be modeled using CLFE2D

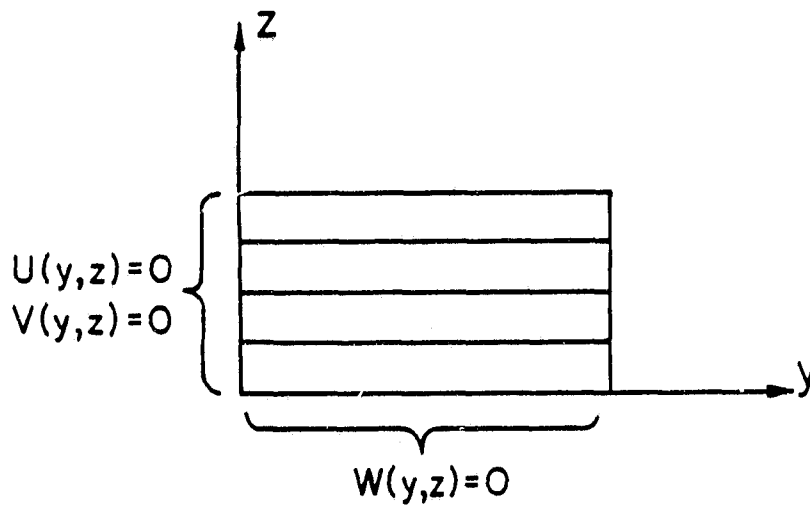

The appropriate boundary conditions for the quarter symmetry model are shown above

Fig. 1.4 Appropriate Boundary Conditions for a Quarter Symmetry Model

## 6.0 Example Problem

Consider an eight ply T300/5208 Graphite Epoxy laminate with a  $[+45_2/-45_2]_S$  stacking sequence. The laminate is 0.50 inches wide and each ply is 0.005 inches thick. It is desired to study the response of the laminate to an applied tensile normal strain  $\epsilon_x^0 = 0.001$ . Of particular interest are the stress, strain and strain energy density distributions along the  $+45^\circ/-45^\circ$  interface.

Solution: A 36 element, 42 node quarter symmetry mesh was developed to study the given problem using CLFE2D. The input file and output for this problem are shown in Appendix A. Note that the stress strain output code varies for each element in the mesh. By doing this, the overall response of the laminate and the response at the  $+45^\circ$ ,  $-45^\circ$  interface can be obtained with a minimum of output.

A simple finite element mesh was used in the solution of the example problem for the purpose of exposition. However, CLFE2D is capable of solving large scale research problems.

## REFERENCES

1. Segerlind, L. J., Applied Finite Element Analysis, John Wiley & Sons, Inc., New York, 1976, pp. 80-84, 314-316.
2. Renieri, G. D., Herakovich, C. T., "Nonlinear Analysis of Laminated Fibrous Composites," VPI-E-76-10, College of Engineering, Virginia Polytechnic Institute & State University, Blacksburg, VA, 1976.

APPENDIX

## EXAMPLE INPUT DATA

EXAMPLE PROBLEM, T300/5208, 8-LAYER, (45.0, 45.0, -45.0, -45.0)S  
 EPSX= 0.001, HYGROTHERMAL LOAD = 0.000

36	42	4	16	0	3	0	0	0	0
	0.01	2.50D-03							
1	1	1	1	1	1				
	32.0	100.0		0.5	0.5				
.1920D+08	1.560D+06	1.560D+06	1.560D+06	.4870D+06	.8200D+06	.8200D+06			
	0.490	0.238	0.238	0.00	.1380D-04	.1380D-04			
	45.0	45.0	-45.0	-45.0					
1	4	9	10	5	1	4			
2	3	8	9	4	2	4	6	1	7
3	2	7	8	3	3	4	9	3	8
4	1	6	7	2	4	4			
5	9	14	15	10	1				
6	8	13	14	9	2	6	1	7	
7	7	12	13	8	3	9	3	8	
8	6	11	12	7	4				
9	15	23	24	15	1	5			
10	14	23	15	14	1	5			
11	14	22	23	14	1	5			
12	14	21	22	14	2	5			
13	13	21	14	13	2	5			
14	13	20	21	13	2	5			
15	13	19	20	13	3	5			
16	12	19	13	12	3	5			
17	12	18	19	12	3	5			
18	12	17	18	12	4	5			
19	11	17	12	11	4	5			
20	11	16	17	11	4	5			
21	23	32	33	24	1				
22	22	31	32	23	1				
23	21	30	31	22	2				
24	20	29	30	21	2	6	1	7	
25	19	28	29	20	3	9	3	8	
26	18	27	28	19	3				
27	17	26	27	18	4				
28	16	25	26	17	4				
29	32	41	42	33	1	5	2		
30	31	40	41	32	1	5			
31	30	39	40	31	2	5			
32	29	38	39	30	2	5	6	1	7
33	28	37	38	29	3	5	9	3	8
34	27	36	37	28	3	5			
35	26	35	36	27	4	5			
36	25	34	35	26	4	5			
1		0.0		0.0					
2		0.0		2.0					
3		0.0		4.0					
4		0.0		6.0					
5		0.0		8.0					
6		8.0		0.0					

MINIMUM QUALITY

7	8.0	2.0
8	8.0	4.0
9	8.0	6.0
10	8.0	8.0
11	16.0	0.0
12	16.0	2.0
13	16.0	4.0
14	16.0	6.0
15	16.0	8.0
16	20.0	0.0
17	20.0	1.0
18	20.0	2.0
19	20.0	3.0
20	20.0	4.0
21	20.0	5.0
22	20.0	6.0
23	20.0	7.0
24	20.0	8.0
25	23.0	0.0
26	23.0	1.0
27	23.0	2.0
28	23.0	3.0
29	23.0	4.0
30	23.0	5.0
31	23.0	6.0
32	23.0	7.0
33	23.0	8.0
34	25.0	0.0
35	25.0	1.0
36	25.0	2.0
37	25.0	3.0
38	25.0	4.0
39	25.0	5.0
40	25.0	6.0
41	25.0	7.0
42	25.0	8.0
1	1	0.0
2	1	0.0
3	1	0.0
4	1	0.0
5	1	0.0
1	2	0.0
2	2	0.0
3	2	0.0
4	2	0.0
5	2	0.0
1	3	0.0
6	3	0.0
11	3	0.0
16	3	0.0
25	3	0.0
34	3	0.0
		0.001
		0.00

ORIGINAL PAGE IS  
OF POOR QUALITY

## EXAMPLE OUTPUT

\*\*\* TWO DIMENSIONAL \*\*\*  
\*\*\* COMPOSITE LAMINATE FINITE ELEMENTS \*\*\*

EXAMPLE PROBLEM, I300/5206, 8-LAYER, (45.0, 45.0, -45.0, -45.0)S  
EPSX= 0.001, HYGROTHERMAL LOAD = 0.000

## \* CONTROL INFORMATION \*

NUMBER OF ELEMENTS .....	36
NUMBER OF NODES .....	42
NUMBER OF DIFFERENT ANGLES .....	4
NUMBER OF SPECIFIED DEGREES OF FREEDOM .....	16
NUMBER OF SPECIFIED BOUNDARY FORCES .....	0
PLOT TYPE .....	3
DUMP FILE FOR DISPLACEMENTS .....	0
DUMP FILE FOR INTER-LAMINAR STRESSES .....	0
DATA CHECK OPTION .....	0

## \* SCALE FACTORS \*

Y - SCALE FACTOR .....	0.1000000D-01
Z - SCALE FACTOR .....	0.2500000D-02

## \* PRINTER CONTROL OPTIONS \*

KEY FOR PRINTING ELEMENT DATA .....	1
KEY FOR PRINTING NODAL DATA .....	1
KEY FOR PRINTING KNOWN DISPLACEMENTS .....	1
KEY FOR PRINTING KNOWN FORCES .....	1
KEY FOR PRINTING NODAL DISPLACEMENTS .....	1
KEY FOR STRAINS, STRESSES AND ENERGIES .....	1

## \* PLOTTER CONTROL INFORMATION \*

Y-PLOT SCALE .....	0.3200000D+02
Z-PLOT SCALE .....	0.1000000D+03
MAXIMUM V-DISPLACEMENT .....	0.5000000D+00
MAXIMUM W-DISPLACEMENT .....	0.5000000D+00

## \* MATERIAL PROPERTIES \*

YOUNGS MODUL I	
E11 .....	0.1920000D+08
E22 .....	0.1560000D+07
E33 .....	0.1560000D+07
SHEAR MODUL I	



ORIGINAL DATA IS  
OF POOR QUALITY

G23 ..... 0.4870000D+06  
 G13 ..... 0.8200000D+06  
 G12 ..... 0.8200000D+06

POISSON RATIOS

U23 ..... 0.4900000D+00  
 U13 ..... 0.2380000D+00  
 U12 ..... 0.2380000D+00

COEFFICIENTS OF THERMAL EXPANSION

ALPH11 ..... 0.0  
 ALPH22 ..... 0.1380000D-04  
 ALPH33 ..... 0.1380000D-04

\* ANGLE INFORMATION \*

ANGLE NO.	THETA IN DEGREES
1	0.4500000D+02
2	0.4500000D+02
3	-0.4500000D+02
4	-0.4500000D+02

\* ELEMENT DATA \*

ELEMENT	NODE-1	NODE-2	NODE-3	NODE-4	ANGLE	STRESS OPTIONS
1	4	9	10	5	1	4 0 0 0 0 0 0 0
2	3	8	9	4	2	4 6 1 7 0 0 0 0
3	2	7	8	3	3	4 9 3 8 0 0 0 0
4	1	6	7	2	4	4 0 0 0 0 0 0 0
5	9	14	15	10	1	0 0 0 0 0 0 0 0
6	8	13	14	9	2	6 1 7 0 0 0 0 0
7	7	12	13	8	3	9 3 8 0 0 0 0 0
8	6	11	12	7	4	0 0 0 0 0 0 0 0
9	15	23	24	15	1	5 0 0 0 0 0 0 0
10	14	23	15	14	1	5 0 0 0 0 0 0 0
11	14	22	23	14	1	5 0 0 0 0 0 0 0
12	14	21	22	14	2	5 0 0 0 0 0 0 0
13	13	21	14	13	2	5 0 0 0 0 0 0 0
14	13	20	21	13	2	5 0 0 0 0 0 0 0
15	13	19	20	13	3	5 0 0 0 0 0 0 0
16	12	19	13	12	3	5 0 0 0 0 0 0 0
17	12	18	19	12	3	5 0 0 0 0 0 0 0
18	12	17	18	12	4	5 0 0 0 0 0 0 0
19	11	17	12	11	4	5 0 0 0 0 0 0 0
20	11	16	17	11	4	5 0 0 0 0 0 0 0
21	23	32	33	24	1	0 0 0 0 0 0 0 0
22	22	31	32	23	1	0 0 0 0 0 0 0 0
23	21	30	31	22	2	0 0 0 0 0 0 0 0
24	20	29	30	21	2	0 0 0 0 0 0 0 0

ORIGINAL PAGE IS  
OF POOR QUALITY

25	19	28	29	20	3	9	3	8	0	0	0	0	0	0
26	18	27	28	19	3	0	0	0	0	0	0	0	0	0
27	17	26	27	18	4	0	0	0	0	0	0	0	0	0
28	16	25	26	17	4	0	0	0	0	0	0	0	0	0
29	32	41	42	33	1	5	2	0	0	0	0	0	0	0
30	31	40	41	32	1	5	0	0	0	0	0	0	0	0
31	30	39	40	31	2	5	0	0	0	0	0	0	0	0
32	29	38	39	30	2	5	6	1	7	0	0	0	0	0
33	28	37	38	29	3	5	9	3	8	0	0	0	0	0
34	27	36	37	28	3	5	0	0	0	0	0	0	0	0
35	26	35	36	27	4	5	0	0	0	0	0	0	0	0
36	25	34	35	26	4	5	0	0	0	0	0	0	0	0

\* THE HALF BANDWIDTH IS 33 COMPUTED IN ELEMENT 21 \*

\* NODAL DATA \*

NODE NO.	Y-COORDINATE	Z-COORDINATE
1	0.0	0.0
2	0.0	0.5000000D-02
3	0.0	0.1000000D-01
4	0.0	0.1500000D-01
5	0.0	0.2000000D-01
6	0.8000000D-01	0.0
7	0.8000000D-01	0.5000000D-02
8	0.8000000D-01	0.1000000D-01
9	0.8000000D-01	0.1500000D-01
10	0.8000000D-01	0.2000000D-01
11	0.1600000D+00	0.0
12	0.1600000D+00	0.5000000D-02
13	0.1600000D+00	0.1000000D-01
14	0.1600000D+00	0.1500000D-01
15	0.1600000D+00	0.2000000D-01
16	0.2000000D+00	0.0
17	0.2000000D+00	0.2500000D-02
18	0.2000000D+00	0.5000000D-02
19	0.2000000D+00	0.7500000D-02
20	0.2000000D+00	0.1000000D-01
21	0.2000000D+00	0.1250000D-01
22	0.2000000D+00	0.1500000D-01
23	0.2000000D+00	0.1750000D-01
24	0.2000000D+00	0.2000000D-01
25	0.2300000D+00	0.0
26	0.2300000D+00	0.2500000D-02
27	0.2300000D+00	0.5000000D-02
28	0.2300000D+00	0.7500000D-02
29	0.2300000D+00	0.1000000D-01
30	0.2300000D+00	0.1250000D-01
31	0.2300000D+00	0.1500000D-01
32	0.2300000D+00	0.1750000D-01
33	0.2300000D+00	0.2000000D-01
34	0.2500000D+00	0.0
35	0.2500000D+00	0.2500000D-02
36	0.2500000D+00	0.5000000D-02
37	0.2500000D+00	0.7500000D-02
38	0.2500000D+00	0.1000000D-01
39	0.2500000D+00	0.1250000D-01

ORIGINAL PAGE 19  
OF POOR QUALITY

40 0.2500000D+00 0.1500000D-01  
 41 0.2500000D+00 0.1750000D-01  
 42 0.2500000D+00 0.2000000D-01

\* UNDEFORMED PLOT COMPLETE \*

\* SPECIFIED DEGREES OF FREEDOM \*

NODE NO.	DIRECTION	SPECIFIED DISPLACEMENT
1	1	0.0
2	1	0.0
3	1	0.0
4	1	0.0
5	1	0.0
1	2	0.0
2	2	0.0
3	2	0.0
4	2	0.0
5	2	0.0
1	3	0.0
3	3	0.0
11	3	0.0
16	3	0.0
25	3	0.0
34	3	0.0

\* STRAIN AND THERMAL LOADS \*

IPSXX ..... 0.1000000D-02  
 TEMPERATURE CHANGE ..... 0.0

\* DEFORMED PLOT COMPLETE \*

DISPLACEMENT SCALE FACTORS ARE V = 0.2741053E+04 W = 0.1143523E+06

\* NODAL DISPLACEMENTS \*

NODE NO.	U-DISPLACEMENT	V-DISPLACEMENT	W-DISPLACEMENT
1	0.0	0.0	0.0
2	0.0	0.0	-0.520491D-06
3	0.0	0.0	-0.1124347D-05
4	0.0	0.0	-0.1686742D-05
5	0.0	0.0	-0.2249079D-05
6	0.5796736D-09	-0.5890739D-04	0.0
7	0.6222065D-09	-0.5890763D-04	-0.5630756D-06
8	0.5361395D-09	-0.5890807D-04	-0.1125600D-05
9	0.4565993D-09	-0.5890890D-04	-0.1687819D-05
10	0.3553318D-09	-0.5890925D-04	-0.2250063D-05
11	-0.1150797D-08	-6.1178197D-03	0.0

ORIGINAL PAGE IS  
OF POOR QUALITY

12	-0.1551461D-08	-0.1178192D-03	-0.5589134D-06
13	-0.1675259D-08	-0.1178183D-03	-0.1119914D-05
14	-0.1495179D-08	-0.1178157D-03	-0.1682372D-05
15	-0.1061953D-08	-0.1178150D-03	-0.2245067D-05
16	-0.4628629D-07	-6.1473419D-03	0.0
17	-0.4312072D-07	-0.1473314D-03	-0.2686268D-06
18	-0.3376679D-07	-0.1473076D-03	-0.5408633D-06
19	-0.2011330D-07	-0.1472844D-03	-0.8187289D-06
20	-0.2331912D-07	-0.1472748D-03	-0.1105637D-05
21	-0.2895740D-07	-0.1472562D-03	-0.1393398D-05
22	-0.1466068D-07	-0.1472513D-03	-0.1674805D-05
23	-0.3349280D-08	-0.1472516D-03	-0.1951650D-05
24	0.8505363D-09	-0.1472472D-03	-0.2227259D-05
25	0.8808159D-06	-0.1691059D-03	0.0
26	0.7824430D-06	-0.1690996D-03	-0.4027785D-06
27	0.5091604D-06	-0.1690696D-03	-0.7889364D-06
28	0.1434451D-06	0.1689963D-03	-0.1143992D-05
29	-0.9468602D-07	-0.1689098D-03	-0.1458850D-05
30	-0.3308369D-06	-0.1688918D-03	-0.1774166D-05
31	-0.6954793D-06	-0.1688595D-03	-0.2128085D-05
32	-0.9680237D-06	-0.1687800D-03	-0.2512411D-05
33	-0.5165715D-05	-0.1686724D-03	-0.2913775D-05
34	0.7065500D-05	-0.1798213D-03	0.0
35	0.6704047D-05	-0.1799856D-03	-0.5961441D-06
36	0.5563581D-05	-0.1804872D-03	-0.1172389D-05
37	0.3444541D-05	-0.1813306D-03	-0.1701912D-05
38	-0.1300820D-06	-0.1824116D-03	-0.2147446D-05
39	-0.3700708D-05	-0.1811846D-03	-6.2598058D-05
40	-0.5826921D-05	-0.1801956D-03	-0.3142349D-05
41	-0.6978620D-05	-0.179530D-03	-0.3742847D-05
42	-0.7346848D-05	-0.1791803D-03	-0.4372451D-05

\* ELEMENT STRESSES AND STRAINS IN GLOBAL X - Y - Z COORDINATES \*

* ELEMENT ( 1 ) STRESSES, STRAINS AND STRAIN ENERGIES PER UNIT VOLUME EVALUATED AT POINT (4) *			
EPSXX = 0.100000D-02	SIGXX = 0.2847602D+04	COORDINATES OF OUTPUT POINTS	
EPSYY = -0.7363634D-03	SIGYY = -0.3374578D-01	Y = 0.0	
EPSZZ = -0.1124674D-03	SIGZZ = -0.1489366D-01	Z = 0.1750000D-01	
GARYZ = -0.1288593D-07	TAUZY = -0.8420953D-02		
GARXZ = 0.0	TAUXZ = -0.2145507D-02		
GARXY = 0.5074569D-08	TAUXY = 0.1168040D+04	STRAIN ENERGY = 0.1423817D+01	

* ELEMENT ( 2 ) STRESSES, STRAINS AND STRAIN ENERGIES PER UNIT VOLUME EVALUATED AT POINT (4) *			
EPSXX = 0.100000D-02	SIGXX = 0.2847633D+04	COORDINATES OF OUTPUT POINTS	
EPSYY = -0.7363561D-03	SIGYY = 0.9324052D-02	Y = 0.0	
EPSZZ = -0.1124790D-03	SIGZZ = -0.3263867D-01	Z = 0.1250000D-01	
GARYZ = -0.1456678D-07	TAUZY = -0.9519391D-02		
GARXZ = 0.0	TAUXZ = -0.2425369D-02		
GARXY = 0.6204618D-08	TAUXY = 0.1168079D+04	STRAIN ENERGY = 0.1423819D+01	

* ELEMENT ( 2 ) STRESSES, STRAINS AND STRAIN ENERGIES PER UNIT VOLUME EVALUATED AT POINT (6) *			
EPSXX = 0.100000D-02	SIGXX = 0.2847661D+04	COORDINATES OF OUTPUT POINTS	
EPSYY = -0.7363509D-03	SIGYY = -0.4937633D-01	Y = 0.0	
EPSZZ = -0.1124790D-03	SIGZZ = -0.3263867D-01	Z = 0.1250000D-01	

ORIGINAL PAGE IS  
OF POOR QUALITY

GARYZ = -0.1566960D-01	IADYZ = -0.1024008D-01	STRAIN ENERGY = 0.1423819D+01
GARXZ = 0.0	IAUXZ = -0.2608988D-02	
GARXY = 0.6701744D-08	IAUXY = 0.1168101D+04	
* ELEMENT ( 2 ) STRESSES, STRAINS AND STRAIN ENERGIES PER UNIT VOLUME EVALUATED AT POINT (1) *		
IPSXX = 0.1000000D-02	SIGXX = 0.2847677D+04	COORDINATES OF OUTPUT POINTS
IPSYY = -0.7363509D-03	SIGYY = 0.6103994D-01	Y = 0.4000000D-01
IPSZZ = -0.1124614D-03	SIGZZ = 0.8565724D-02	Z = 0.1000000D-01
GARYZ = -0.9781530D-07	IADYZ = -0.6524664D-01	
GARXZ = -0.7954016D-08	IAUXZ = -0.2348420D-01	STRAIN ENERGY = 0.1423819D+01
GARXY = 0.6701744D-08	IAUXY = 0.1168101D+04	
* ELEMENT ( 2 ) STRESSES, STRAINS AND STRAIN ENERGIES PER UNIT VOLUME EVALUATED AT POINT (7) *		
IPSXX = 0.1000000D-02	SIGXX = 0.2847692D+04	COORDINATES OF OUTPUT POINTS
IPSYY = -0.7363509D-03	SIGYY = 0.7676356D-01	Y = 0.8000000D-01
IPSZZ = -0.1124437D-03	SIGZZ = 0.4528528D-01	Z = 0.1000000D-01
GARYZ = -0.1799610D-06	IADYZ = -0.1202532D+00	
GARXZ = -0.1590803D-07	IAUXZ = -0.4035541D-01	STRAIN ENERGY = 0.1423819D+01
GARXY = 0.6701744D-08	IAUXY = 0.1168099D+04	
* ELEMENT ( 3 ) STRESSES, STRAINS AND STRAIN ENERGIES PER UNIT VOLUME EVALUATED AT POINT (4) *		
IPSXX = 0.1000000D-02	SIGXX = 0.2847631D+04	COORDINATES OF OUTPUT POINTS
IPSYY = -0.7363481D-03	SIGYY = 0.2027050D-01	Y = 0.0
IPSZZ = -0.1124595D-03	SIGZZ = 0.1695048D-01	Z = 0.7500000D-02
GARYZ = -0.1425055D-07	IADYZ = -0.9312736D-02	
GARXZ = 0.0	IAUXZ = 0.2372717D-02	STRAIN ENERGY = 0.1423803D+01
GARXY = 0.7239663D-08	IAUXY = -0.1168043D+04	
* ELEMENT ( 3 ) STRESSES, STRAINS AND STRAIN ENERGIES PER UNIT VOLUME EVALUATED AT POINT (9) *		
IPSXX = 0.1000000D-02	SIGXX = 0.2847620D+04	COORDINATES OF OUTPUT POINTS
IPSYY = -0.7363509D-03	SIGYY = 0.4139980D-02	Y = 0.0
IPSZZ = -0.1124595D-03	SIGZZ = 0.1438586D-01	Z = 0.1000000D-01
GARYZ = -0.1566960D-07	IADYZ = -0.1024008D-01	
GARXZ = 0.0	IAUXZ = 0.2608988D-02	STRAIN ENERGY = 0.1423804D+01
GARXY = 0.6701744D-08	IAUXY = -0.1168034D+04	
* ELEMENT ( 3 ) STRESSES, STRAINS AND STRAIN ENERGIES PER UNIT VOLUME EVALUATED AT POINT (3) *		
IPSXX = 0.1000000D-02	SIGXX = 0.2847600D+04	COORDINATES OF OUTPUT POINTS
IPSYY = -0.7363509D-03	SIGYY = -0.1601514D-01	Y = 0.4000000D-01
IPSZZ = -0.1124822D-03	SIGZZ = -0.3286291D-01	Z = 0.1000000D-01
GARYZ = -0.6047557D-07	IADYZ = -0.3808777D-01	
GARXZ = -0.8606703D-08	IAUXZ = 0.4444703D-02	STRAIN ENERGY = 0.1423804D+01
GARXY = 0.6701744D-08	IAUXY = -0.1168037D+04	
* ELEMENT ( 3 ) STRESSES, STRAINS AND STRAIN ENERGIES PER UNIT VOLUME EVALUATED AT POINT (8) *		
IPSXX = 0.1000000D-02	SIGXX = 0.2847579D+04	COORDINATES OF OUTPUT POINTS
IPSYY = -0.7363509D-03	SIGYY = -0.3617026D-01	Y = 0.8000000D-01
IPSZZ = -0.1125049D-03	SIGZZ = -0.8011169D-01	Z = 0.1000000D-01
GARYZ = -0.1052816D-06	IADYZ = -0.6593546D-01	
GARXZ = -0.1721341D-07	IAUXZ = -0.6280418D-02	STRAIN ENERGY = 0.1423804D+01
GARXY = 0.6701744D-08	IAUXY = -0.1168040D+04	

ORIGINAL PAGE IS  
OF POOR QUALITY

\* ELEMENT ( 4 ) STRESSES, STRAINS AND STRAIN ENERGIES PER UNIT VOLUME EVALUATED AT POINT (4) \*

EPSXX = 0.1000000D-02      SIGXX = 0.2847695D+04  
 EPSYY = -0.7363438D-03      SIGYY = 0.915759D-01  
 EPSZZ = -0.1124098D-03      SIGZZ = 0.1241879D+00  
 GAMYZ = -0.6415734D-08      TAUZY = -0.4192695D-02  
 GAMXZ = 0.0                    TAUZX = 0.1068223D-02  
 GAMXY = 0.7511751D-08      TAUXY = -0.1168053D+04

COORDINATES OF OUTPUT POINTS  
 Y = 0.0  
 Z = 0.2500000D-02

STRAIN ENERGY = 0.1423803D+01

\* ELEMENT ( 6 ) STRESSES, STRAINS AND STRAIN ENERGIES PER UNIT VOLUME EVALUATED AT POINT (6) \*

EPSXX = 0.1000000D-02      SIGXX = 0.2847406D+04  
 EPSYY = -0.7363783D-03      SIGYY = -0.2541396D+00  
 EPSZZ = -0.1124437D-03      SIGZZ = 0.2598605D-01  
 GAMYZ = -0.9320772D-07      TAUZY = -0.6355993D-01  
 GAMXZ = -0.1590803D-07      TAUZX = -0.2591499D-01  
 GAMXY = -0.2764248D-07      TAUXY = 0.1167806D+04

COORDINATES OF OUTPUT POINTS  
 Y = 0.8000000D-01  
 Z = 0.1000000D-01

STRAIN ENERGY = 0.1423779D+01

\* ELEMENT ( 6 ) STRESSES, STRAINS AND STRAIN ENERGIES PER UNIT VOLUME EVALUATED AT POINT (1) \*

EPSXX = 0.1000000D-02      SIGXX = 0.2847385D+04  
 EPSYY = -0.7363783D-03      SIGYY = -0.2754056D+00  
 EPSZZ = -0.1124677D-03      SIGZZ = -0.2386693D-01  
 GAMYZ = 0.2500133D-06      TAUZY = 0.1650577D+00  
 GAMXZ = 0.1005401D-07      TAUZX = 0.4819750D-01  
 GAMXY = -0.2764248D-07      TAUXY = 0.1167810D+04

COORDINATES OF OUTPUT POINTS  
 Y = 0.1200000D+00  
 Z = 0.1000000D-01

STRAIN ENERGY = 0.1423779D+01

\* ELEMENT ( 6 ) STRESSES, STRAINS AND STRAIN ENERGIES PER UNIT VOLUME EVALUATED AT POINT (7) \*

EPSXX = 0.1000000D-02      SIGXX = 0.2847364D+04  
 EPSYY = -0.7363783D-03      SIGYY = -0.2966716D+00  
 EPSZZ = -0.1124916D-03      SIGZZ = -0.7371991D-01  
 GAMYZ = 0.5932342D-06      TAUZY = 0.3936752D+00  
 GAMXZ = 0.3601605D-07      TAUZX = 0.1223100D+00  
 GAMXY = -0.2764248D-07      TAUXY = 0.1167813D+04

COORDINATES OF OUTPUT POINTS  
 Y = 0.1600000D+00  
 Z = 0.1000000D-01

STRAIN ENERGY = 0.1423779D+01

\* ELEMENT ( 7 ) STRESSES, STRAINS AND STRAIN ENERGIES PER UNIT VOLUME EVALUATED AT POINT (9) \*

EPSXX = 0.1000000D-02      SIGXX = 0.2847593D+04  
 EPSYY = -0.7363783D-03      SIGYY = -0.6698420D-01  
 EPSZZ = -0.1125049D-03      SIGZZ = -0.1094618D+00  
 GAMYZ = -0.1852828D-07      TAUZY = -0.3242197D-02  
 GAMXZ = -0.1721341D-07      TAUZX = -0.8164002D-02  
 GAMXY = -0.2764248D-07      TAUXY = -0.1168094D+04

COORDINATES OF OUTPUT POINTS  
 Y = 0.8000000D-01  
 Z = 0.1000000D-01

STRAIN ENERGY = 0.1423804D+01

\* ELEMENT ( 7 ) STRESSES, STRAINS AND STRAIN ENERGIES PER UNIT VOLUME EVALUATED AT POINT (3) \*

EPSXX = 0.1000000D-02      SIGXX = 0.2847729D+04  
 EPSYY = -0.7363783D-03      SIGYY = 0.6834569D-01  
 EPSZZ = -0.1123525D-03      SIGZZ = 0.2077862D+00  
 GAMYZ = 0.1089535D-06      TAUZY = 0.7469535D-01  
 GAMXZ = -0.2098653D-07      TAUZX = -0.3185545D-01  
 GAMXY = -0.2764248D-07      TAUXY = -0.1168071D+04

COORDINATES OF OUTPUT POINTS  
 Y = 0.1200000D+00  
 Z = 0.1000000D-01

STRAIN ENERGY = 0.1423804D+01

\* ELEMENT ( 7 ) STRESSES, STRAINS AND STRAIN ENERGIES PER UNIT VOLUME EVALUATED AT POINT (5) \*

EPSXX = 0.1000000D-02	SIGXX = 0.2847864D+04	COORDINATES OF OUTPUT POINTS
EPSYY = -0.7363783D-03	SIGYY = 0.2036756D+00	Y = 0.1600000D+00
EPSZZ = -0.1122000D-03	SIGZZ = 0.5250342D+00	Z = 0.1000000D-01
GARYZ = 0.2364352D-06	TAUYZ = 0.1586329D+00	
GARXZ = -0.2475966D-07	TAUXZ = -0.5554690D-01	
GARXY = -0.2764248D-07	TAUXY = -0.1168049D+04	STRAIN ENERGY = 0.1423844D+01
* ELEMENT ( 9 ) STRESSES, STRAINS AND STRAIN ENERGIES PER UNIT VOLUME EVALUATED AT POINT (5) *		
EPSXX = 0.1000000D-02	SIGXX = 0.2852526D+04	COORDINATES OF OUTPUT POINTS
EPSYY = -0.7358062D-03	SIGYY = 0.5804273D+01	Y = 0.1600000D+00
EPSZZ = -0.1102436D-03	SIGZZ = 0.5101355D+01	Z = 0.1937500D-01
GARYZ = 0.2197365D-05	TAUYZ = 0.1715686D+01	
GARXZ = 0.1679926D-05	TAUXZ = 0.1463693D+01	
GARXY = 0.4781223D-07	TAUXY = 0.1170363D+04	STRAIN ENERGY = 0.1423878D+01
* ELEMENT ( 10 ) STRESSES, STRAINS AND STRAIN ENERGIES PER UNIT VOLUME EVALUATED AT POINT (5) *		
EPSXX = 0.1000000D-02	SIGXX = 0.2849599D+04	COORDINATES OF OUTPUT POINTS
EPSYY = -0.7359060D-03	SIGYY = 0.2672928D+01	Y = 0.1700000D+00
EPSZZ = -0.1125390D-03	SIGZZ = 0.2504213D+00	Z = 0.1687500D-01
GARYZ = 0.4569025D-06	TAUYZ = 0.3130122D+00	
GARXZ = 0.8664523D-07	TAUXZ = 0.1326969D+00	
GARXY = -0.5176785D-07	TAUXY = 0.1169762D+04	STRAIN ENERGY = 0.1423752D+01
* ELEMENT ( 11 ) STRESSES, STRAINS AND STRAIN ENERGIES PER UNIT VOLUME EVALUATED AT POINT (5) *		
EPSXX = 0.1000000D-02	SIGXX = 0.2850033D+04	COORDINATES OF OUTPUT POINTS
EPSYY = -0.7358885D-03	SIGYY = 0.3175366D+01	Y = 0.1800000D+00
EPSZZ = -0.1107379D-03	SIGZZ = 0.4054666D+01	Z = 0.1562500D-01
GARYZ = 0.6525234D-07	TAUYZ = 0.7959820D+00	
GARXZ = 0.4524562D-05	TAUXZ = 0.2967666D+01	
GARXY = -0.3291376D-06	TAUXY = 0.1168177D+04	STRAIN ENERGY = 0.1423438D+01
* ELEMENT ( 12 ) STRESSES, STRAINS AND STRAIN ENERGIES PER UNIT VOLUME EVALUATED AT POINT (5) *		
EPSXX = 0.1000000D-02	SIGXX = 0.2848413D+04	COORDINATES OF OUTPUT POINTS
EPSYY = -0.7358885D-03	SIGYY = 0.1554435D+01	Y = 0.1800000D+00
EPSZZ = -0.1125628D-03	SIGZZ = 0.2571318D+00	Z = 0.1437500D-01
GARYZ = 0.2153839D-05	TAUYZ = 0.2359695D+01	
GARXZ = 0.5718688D-05	TAUXZ = 0.4095776D+01	
GARXY = -0.3291376D-06	TAUXY = 0.1168444D+04	STRAIN ENERGY = 0.1423441D+01
* ELEMENT ( 13 ) STRESSES, STRAINS AND STRAIN ENERGIES PER UNIT VOLUME EVALUATED AT POINT (5) *		
EPSXX = 0.1000000D-02	SIGXX = 0.2846477D+04	COORDINATES OF OUTPUT POINTS
EPSYY = -0.7359787D-03	SIGYY = -0.5277370D+00	Y = 0.1700000D+00
EPSZZ = -0.1124916D-03	SIGZZ = 0.3771197D+00	Z = 0.1187500D-01
GARYZ = 0.7157562D-06	TAUYZ = 0.4737434D+00	
GARXZ = 0.5601505D-07	TAUXZ = 0.1427099D+00	
GARXY = -0.6843046D-06	TAUXY = 0.1166250D+04	STRAIN ENERGY = 0.1423013D+01
* ELEMENT ( 14 ) STRESSES, STRAINS AND STRAIN ENERGIES PER UNIT VOLUME EVALUATED AT POINT (5) *		
EPSXX = 0.1000000D-02	SIGXX = 0.2842641D+04	COORDINATES OF OUTPUT POINTS
EPSYY = -0.7364106D-03	SIGYY = -0.5071973D+01	Y = 0.1800000D+00

ORIGINAL PAGE IS  
OF POOR QUALITY

EPSZZ = -0.1151046D-03	SIGZZ = -0.5464958D+01	Z = 0.1062500D-01
GARYZ = 0.7789448D-05	TAUZY = 0.4714894D+01	
GAPXZ = -0.2255313D-05	TAUXZ = -0.1769042D+00	
GAPXY = -0.5410965D-06	TAUXY = 0.1165468D+04	STRAIN ENERGY = 0.1423206D+01
* ELEMENT ( 15 ) STRESSES, STRAINS AND STRAIN ENERGIES PER UNIT VOLUME EVALUATED AT POINT (5) *		
EPSXX = 0.1000000D-02	SIGXX = 0.2847672D+04	
EPSYY = -0.7364106D-03	SIGYY = -0.4182433D-01	COORDINATES OF OUTPUT POINTS
EPSZZ = -0.1147631D-03	SIGZZ = -0.4912624D+01	Y = 0.1800000D+00
GARYZ = 0.4200033D-05	TAUZY = 0.2958229D+01	Z = 0.9375000D-02
GAPXZ = -0.1282330D-05	TAUXZ = -0.1537308D+01	
GAPXY = -0.5410965D-06	TAUXY = -0.1170870D+04	STRAIN ENERGY = 0.1424457D+01
* ELEMENT ( 16 ) STRESSES, STRAINS AND STRAIN ENERGIES PER UNIT VOLUME EVALUATED AT POINT (5) *		
EPSXX = 0.1000000D-02	SIGXX = 0.2848464D+04	
EPSYY = -0.7366405D-03	SIGYY = 0.3732725D+00	COORDINATES OF OUTPUT POINTS
EPSZZ = -0.1122000D-03	SIGZZ = 0.2287089D+00	Y = 0.1700000D+00
GARYZ = 0.6824657D-06	TAUZY = 0.4501138D+00	Z = 0.6875000D-02
GAPXZ = -0.2475966D-07	TAUXZ = -0.1298110D+00	
GAPXY = -0.4624984D-06	TAUXY = -0.1169095D+04	STRAIN ENERGY = 0.1424352D+01
* ELEMENT ( 17 ) STRESSES, STRAINS AND STRAIN ENERGIES PER UNIT VOLUME EVALUATED AT POINT (5) *		
EPSXX = 0.1000000D-02	SIGXX = 0.2848064D+04	
EPSYY = -0.7372117D-03	SIGYY = -0.9630915D+00	COORDINATES OF OUTPUT POINTS
EPSZZ = -0.111462D-03	SIGZZ = 0.1864367D+01	Y = 0.1800000D+00
GARYZ = 0.5755963D-05	TAUZY = 0.5466199D+01	Z = 0.5625000D-02
GAPXZ = 0.5461400D-05	TAUXZ = 0.1944657D+01	
GAPXY = -0.8053833D-06	TAUXY = -0.1168173D+04	STRAIN ENERGY = 0.1424786D+01
* ELEMENT ( 18 ) STRESSES, STRAINS AND STRAIN ENERGIES PER UNIT VOLUME EVALUATED AT POINT (5) *		
EPSXX = 0.1000000D-02	SIGXX = 0.2850063D+04	
EPSYY = -0.7372117D-03	SIGYY = 0.1035728D+01	COORDINATES OF OUTPUT POINTS
EPSZZ = -0.1088946D-03	SIGZZ = 0.6550114D+01	Y = 0.1800000D+00
GARYZ = 0.9941424D-05	TAUZY = 0.5873749D+01	Z = 0.4375000D-02
GAPXZ = 0.3741572D-05	TAUXZ = 0.7898701D+00	
GAPXY = -0.8053833D-06	TAUXY = -0.1167843D+04	STRAIN ENERGY = 0.1424794D+01
* ELEMENT ( 19 ) STRESSES, STRAINS AND STRAIN ENERGIES PER UNIT VOLUME EVALUATED AT POINT (5) *		
EPSXX = 0.1000000D-02	SIGXX = 0.2845636D+04	
EPSYY = -0.737978D-03	SIGYY = -0.4352805D+01	COORDINATES OF OUTPUT POINTS
EPSZZ = -0.1117827D-03	SIGZZ = -0.1534368D-01	Y = 0.1700000D+00
GARYZ = 0.3826162D-06	TAUZY = 0.2633318D+00	Z = 0.1875000D-02
GAPXZ = -0.8013271D-07	TAUXZ = -0.1160723D+00	
GAPXY = -0.1044240D-05	TAUXY = -0.1166909D+04	STRAIN ENERGY = 0.1425034D+01
* ELEMENT ( 20 ) STRESSES, STRAINS AND STRAIN ENERGIES PER UNIT VOLUME EVALUATED AT POINT (5) *		
EPSXX = 0.1000000D-02	SIGXX = 0.2848582D+04	
EPSYY = -0.7380532D-03	SIGYY = -0.1825230D+01	COORDINATES OF OUTPUT POINTS
EPSZZ = -0.1074507D-03	SIGZZ = 0.8760470D+01	Y = 0.1800000D+00
GARYZ = 0.4198409D-05	TAUZY = 0.2532834D+01	Z = 0.6250000D-03
GAPXZ = 0.1266226D-05	TAUXZ = 0.1266226D+01	



ORIGINAL PAGE IS  
OF POOR QUALITY

GAMXY = -0.1128387D-05      TAUXY = -0.1165583D+04      STRAIN ENERGY = 0.1425157D+01

\* ELEMENT ( 24 ) STRESSES, STRAINS AND STRAIN ENERGIES PER UNIT VOLUME EVALUATED AT POINT (6) \*

EPSXX = 0.1000000D-02      SIGXX = 0.2910211D+04      COORDINATES OF OUTPUT POINTS  
 EPSYY = -0.7211667D-03      SIGYY = 0.8749756D+02      Y = 0.2000000D+00  
 EPSZZ = -0.1151046D-03      SIGZZ = 0.8336063D+01      Z = 0.1000000D-01  
 GAMYZ = -0.4341252D-05      TAUYZ = -0.3212518D+01  
 GAMXZ = -0.2255313D-05      TAUZX = -0.2196666D+01  
 GAMXY = -0.2378897D-05      TAUXY = 0.1222794D+04      STRAIN ENERGY = 0.1421631D+01

\* ELEMENT ( 24 ) STRESSES, STRAINS AND STRAIN ENERGIES PER UNIT VOLUME EVALUATED AT POINT (1) \*

EPSXX = 0.1000000D-02      SIGXX = 0.2905319D+04      COORDINATES OF OUTPUT POINTS  
 EPSYY = -0.7211667D-03      SIGYY = 0.8260548D+02      Y = 0.2150000D+00  
 EPSZZ = -0.1206156D-03      SIGZZ = -0.3132245D+01      Z = 0.1000000D-01  
 GAMYZ = -0.4456339D-05      TAUYZ = -0.1096380D+02  
 GAMXZ = -0.4835783D-04      TAUZX = -0.3234382D+02  
 GAMXY = -0.2378897D-05      TAUXY = 0.1223610D+04      STRAIN ENERGY = 0.1422413D+01

\* ELEMENT ( 24 ) STRESSES, STRAINS AND STRAIN ENERGIES PER UNIT VOLUME EVALUATED AT POINT (7) \*

EPSXX = 0.1000000D-02      SIGXX = 0.2900427D+04      COORDINATES OF OUTPUT POINTS  
 EPSYY = -0.7211667D-03      SIGYY = 0.7771339D+02      Y = 0.2300000D+00  
 EPSZZ = -0.1261265D-03      SIGZZ = -0.1460059D+02      Z = 0.1000000D-01  
 GAMYZ = -0.4571425D-05      TAUYZ = -0.1871507D+02  
 GAMXZ = -0.9446034D-04      TAUZX = -0.6249097D+02  
 GAMXY = -0.2378897D-05      TAUXY = 0.1224407D+04      STRAIN ENERGY = 0.1424650D+01

\* ELEMENT ( 25 ) STRESSES, STRAINS AND STRAIN ENERGIES PER UNIT VOLUME EVALUATED AT POINT (9) \*

EPSXX = 0.1000000D-02      SIGXX = 0.2931296D+04      COORDINATES OF OUTPUT POINTS  
 EPSYY = -0.7211667D-03      SIGYY = 0.1085826D+03      Y = 0.2000000D+00  
 EPSZZ = -0.1147631D-03      SIGZZ = 0.8350561D+01      Z = 0.1000000D-01  
 GAMYZ = -0.7930667D-05      TAUYZ = -0.4969183D+01  
 GAMXZ = -0.1282330D-05      TAUZX = 0.4824535D+00  
 GAMXY = -0.2378897D-05      TAUXY = -0.1246713D+04      STRAIN ENERGY = 0.1427518D+01

\* ELEMENT ( 25 ) STRESSES, STRAINS AND STRAIN ENERGIES PER UNIT VOLUME EVALUATED AT POINT (3) \*

EPSXX = 0.1000000D-02      SIGXX = 0.2926334D+04      COORDINATES OF OUTPUT POINTS  
 EPSYY = -0.7211667D-03      SIGYY = 0.1036202D+03      Y = 0.2150000D+00  
 EPSZZ = -0.1203533D-03      SIGZZ = -0.3282607D+01      Z = 0.1000000D-01  
 GAMYZ = -0.7449457D-05      TAUYZ = 0.1290474D+02  
 GAMXZ = -0.4826739D-04      TAUZX = -0.3278307D+02  
 GAMXY = -0.2378897D-05      TAUXY = -0.1247531D+04      STRAIN ENERGY = 0.1428324D+01

\* ELEMENT ( 25 ) STRESSES, STRAINS AND STRAIN ENERGIES PER UNIT VOLUME EVALUATED AT POINT (8) \*

EPSXX = 0.1000000D-02      SIGXX = 0.2921371D+04      COORDINATES OF OUTPUT POINTS  
 EPSYY = -0.7211667D-03      SIGYY = 0.9865781D+02      Y = 0.2300000D+00  
 EPSZZ = -0.1259434D-03      SIGZZ = -0.1491577D+02      Z = 0.1000000D-01  
 GAMYZ = 0.2282958D-04      TAUYZ = 0.3077866D+02  
 GAMXZ = -0.9525244D-04      TAUZX = -0.6604860D+02  
 GAMXY = -0.2378897D-05      TAUXY = -0.1248349D+04      STRAIN ENERGY = 0.1431032D+01

ORIGINAL PAGE 13  
OF POOR QUALITY

\* ELEMENT ( 29 ) STRESSES, STRAINS AND STRAIN ENERGIES PER UNIT VOLUME EVALUATED AT POINT (5) \*

EPSXX = 0.1000000D-02      SIGXX = 0.2437638D+04  
 EPSYY = -0.5315795D-03      SIGYY = -0.7410230D+02  
 EPSZZ = -0.2061937D-03      SIGZZ = 0.3169323D+02  
 GAMYZ = 0.2529637D-04      TAUZY = 0.1016066D+01  
 GAMXZ = -0.9318384D-04      TAUZX = -0.5668379D+02  
 GAMXY = -0.3072932D-03      TAUXY = 0.5281407D+03

COORDINATES OF OUTPUT POINTS  
 Y = 0.2400000D+00  
 Z = 0.1875000D-01

STRAIN ENERGY = 0.1156779D+01

\* ELEMENT ( 29 ) STRESSES, STRAINS AND STRAIN ENERGIES PER UNIT VOLUME EVALUATED AT POINT (2) \*

EPSXX = 0.1000000D-02      SIGXX = 0.2397166D+04  
 EPSYY = -0.5315795D-03      SIGYY = -0.1146246D+03  
 EPSZZ = -0.2518420D-03      SIGZZ = -0.6330138D+02  
 GAMYZ = 0.7478255D-04      TAUZY = 0.2434641D+02  
 GAMXZ = -0.1472912D-03      TAUZX = -0.8380350D+02  
 GAMXY = -0.3072932D-03      TAUXY = 0.5348202D+03

COORDINATES OF OUTPUT POINTS  
 Y = 0.2500000D+00  
 Z = 0.1875000D-01

STRAIN ENERGY = 0.1161929D+01

\* ELEMENT ( 30 ) STRESSES, STRAINS AND STRAIN ENERGIES PER UNIT VOLUME EVALUATED AT POINT (5) \*

EPSXX = 0.1000000D-02      SIGXX = 0.2468715D+04  
 EPSYY = -0.5522908D-03      SIGYY = -0.7704170D+02  
 EPSZZ = -0.1969647D-03      SIGZZ = 0.2830757D+02  
 GAMYZ = 0.9186637D-04      TAUZY = 0.1260735D+02  
 GAMXZ = -0.2848488D-03      TAUZX = -0.1708529D+03  
 GAMXY = -0.2789509D-03      TAUXY = 0.5811215D+03

COORDINATES OF OUTPUT POINTS  
 Y = 0.2400000D+00  
 Z = 0.1625000D-01

STRAIN ENERGY = 0.1196821D+01

\* ELEMENT ( 31 ) STRESSES, STRAINS AND STRAIN ENERGIES PER UNIT VOLUME EVALUATED AT POINT (5) \*

EPSXX = 0.1000000D-02      SIGXX = 0.2581841D+04  
 EPSYY = -0.5907282D-03      SIGYY = -0.2695345D+02  
 EPSZZ = -0.1796420D-03      SIGZZ = 0.2057510D+02  
 GAMYZ = 0.1582613D-03      TAUZY = 0.2047830D+02  
 GAMXZ = -0.4981710D-03      TAUZX = -0.2992042D+03  
 GAMXY = -0.2125328D-03      TAUXY = 0.7432786D+03

COORDINATES OF OUTPUT POINTS  
 Y = 0.2400000D+00  
 Z = 0.1375000D-01

STRAIN ENERGY = 0.1294196D+01

\* ELEMENT ( 32 ) STRESSES, STRAINS AND STRAIN ENERGIES PER UNIT VOLUME EVALUATED AT POINT (5) \*

EPSXX = 0.1000000D-02      SIGXX = 0.2893330D+04  
 EPSYY = -0.6448665D-03      SIGYY = 0.1957190D+03  
 EPSZZ = -0.1531857D-03      SIGZZ = 0.8930004D+01  
 GAMYZ = 0.2112013D-03      TAUZY = 0.1125438D+02  
 GAMXZ = -0.7613553D-03      TAUZX = -0.4623807D+03  
 GAMXY = -0.8513168D-04      TAUXY = 0.1144753D+04

COORDINATES OF OUTPUT POINTS  
 Y = 0.2400000D+00  
 Z = 0.1125000D-01

STRAIN ENERGY = 0.1511344D+01

\* ELEMENT ( 32 ) STRESSES, STRAINS AND STRAIN ENERGIES PER UNIT VOLUME EVALUATED AT POINT (6) \*

EPSXX = 0.1000000D-02      SIGXX = 0.3131575D+04  
 EPSYY = -0.6750929D-03      SIGYY = 0.3844229D+03  
 EPSZZ = -0.1261265D-03      SIGZZ = 0.2621037D+02  
 GAMYZ = -0.2722742D-04      TAUZY = -0.3352076D+02  
 GAMXZ = -0.9446034D-04      TAUZX = -0.6626320D+02  
 GAMXY = -0.1769801D-05      TAUXY = 0.1428725D+04

COORDINATES OF OUTPUT POINTS  
 Y = 0.2300000D+00  
 Z = 0.1000000D-01

STRAIN ENERGY = 0.1436696D+01

\* ELEMENT ( 32 ) STRESSES, STRAINS AND STRAIN ENERGIES PER UNIT VOLUME EVALUATED AT POINT (1) \*

EPSXX = 0.1000000D-02      SIGXX = 0.3131575D+04  
 EPSYY = -0.6750929D-03      SIGYY = 0.3844229D+03  
 EPSZZ = -0.1261265D-03      SIGZZ = 0.2621037D+02  
 GAMYZ = -0.2722742D-04      TAUZY = -0.3352076D+02  
 GAMXZ = -0.9446034D-04      TAUZX = -0.6626320D+02  
 GAMXY = -0.1769801D-05      TAUXY = 0.1428725D+04

COORDINATES OF OUTPUT POINTS

ORIGINAL PAGE IS  
OF POOR QUALITY

EPSYY = -0.6750929D-03	SIGYY = 0.3604023D+03	Y = 0.2400000D+00
EPSZZ = -0.1531857D-03	SIGZZ = -0.3010013D+02	Z = 0.1000000D-01
GARYZ = 0.2145837D-03	TAUZY = 0.1346478D+02	
GAPXZ = -0.7613553D-03	TAUXZ = -0.4618175D+03	
GAMPY = -0.1769801D-05	TAUXY = 0.1432684D+04	
* ELEMENT ( 32 ) STRESSES, STRAINS AND STRAIN ENERGIES PER UNIT VOLUME EVALUATED AT POINT ( 7 ) *		
EPSXX = 0.1000000D-02	SIGXX = 0.3083534D+04	COORDINATES OF OUTPUT POINTS
EPSYY = -0.6750929D-03	SIGYY = 0.3363817D+03	Y = 0.2500000D+00
EPSZZ = -0.1802449D-03	SIGZZ = -0.8641063D+02	Z = 0.1000000D-01
GARYZ = 0.4563948D-03	TAUZY = 0.6045032D+02	
GAPXZ = -0.1428250D-02	TAUXZ = -0.8573719D+03	
GAMPY = -0.1769801D-05	TAUXY = 0.1436644D+04	STRAIN ENERGY = 0.2060804D+01
* ELEMENT ( 33 ) STRESSES, STRAINS AND STRAIN ENERGIES PER UNIT VOLUME EVALUATED AT POINT ( 5 ) *		
EPSXX = 0.1000000D-02	SIGXX = 0.2904401D+04	COORDINATES OF OUTPUT POINTS
EPSYY = -0.6459050D-03	SIGYY = 0.2051164D+03	Y = 0.2400000D+00
EPSZZ = -0.1520784D-03	SIGZZ = 0.9801398D+01	Z = 0.8750000D-02
GARYZ = -0.2360592D-03	TAUZY = -0.2337896D+02	
GAPXZ = -0.7625509D-03	TAUXZ = -0.4600222D+03	
GAMPY = 0.8164251D-04	TAUXY = -0.1157630D+04	STRAIN ENERGY = 0.1516041D+01
* ELEMENT ( 33 ) STRESSES, STRAINS AND STRAIN ENERGIES PER UNIT VOLUME EVALUATED AT POINT ( 9 ) *		
EPSXX = 0.1000000D-02	SIGXX = 0.3147199D+04	COORDINATES OF OUTPUT POINTS
EPSYY = -0.6750929D-03	SIGYY = 0.4000463D+03	Y = 0.2300000D+00
EPSZZ = -0.1259434D-03	SIGZZ = 0.2607340D+02	Z = 0.1000000D-01
GARYZ = 0.1735867D-06	TAUZY = 0.1597297D+02	
GAPXZ = -0.9525244D-04	TAUXZ = -0.6227637D+02	
GAMPY = -0.1769801D-05	TAUXY = -0.1446530D+04	STRAIN ENERGY = 0.1441171D+01
* ELEMENT ( 33 ) STRESSES, STRAINS AND STRAIN ENERGIES PER UNIT VOLUME EVALUATED AT POINT ( 3 ) *		
EPSXX = 0.1000000D-02	SIGXX = 0.3123998D+04	COORDINATES OF OUTPUT POINTS
EPSYY = -0.6750929D-03	SIGYY = 0.3768461D+03	Y = 0.2400000D+00
EPSZZ = -0.1520784D-03	SIGZZ = -0.2831388D+02	Z = 0.1000000D-01
GARYZ = -0.2333267D-03	TAUZY = -0.2551387D+02	
GAPXZ = -0.7625509D-03	TAUXZ = -0.4594782D+03	
GAMPY = -0.1769801D-05	TAUXY = -0.1450354D+04	STRAIN ENERGY = 0.1616397D+01
* ELEMENT ( 33 ) STRESSES, STRAINS AND STRAIN ENERGIES PER UNIT VOLUME EVALUATED AT POINT ( 8 ) *		
EPSXX = 0.1000000D-02	SIGXX = 0.3100798D+04	COORDINATES OF OUTPUT POINTS
EPSYY = -0.6750929D-03	SIGYY = 0.3536458D+03	Y = 0.2500000D+00
EPSZZ = -0.1782135D-03	SIGZZ = -0.670117D+02	Z = 0.1000000D-01
GARYZ = -0.4668257D-03	TAUZY = -0.6700070D+02	
GAPXZ = -0.1429849D-02	TAUXZ = -0.8566801D+03	
GAMPY = -0.1769801D-05	TAUXY = -0.1454178D+04	STRAIN ENERGY = 0.2067784D+01
* ELEMENT ( 34 ) STRESSES, STRAINS AND STRAIN ENERGIES PER UNIT VOLUME EVALUATED AT POINT ( 5 ) *		
EPSXX = 0.1000000D-02	SIGXX = 0.2584951D+04	COORDINATES OF OUTPUT POINTS
EPSYY = -0.5937994D-03	SIGYY = -0.2887958D+02	Y = 0.2400000D+00
EPSZZ = -0.1769156D-03	SIGZZ = 0.2298914D+02	Z = 0.6250000D-02
GARYZ = -0.1775405D-03	TAUZY = -0.3328036D+02	

GAHXZ = -0.4969510D-03  
 GAHXY = 0.2088879D-03  
 IAUXX = -0.2951970D+03  
 IAUXY = -0.7478271D+03  
 STRAIN ENERGY = 0.1297214D+01

\* ELEMENT ( 35 ) STRESSES, STRAINS AND STRAIN ENERGIES PER UNIT VOLUME EVALUATED AT POINT (5) \*

I PSXX = 0.1000000D-02  
 I PSYY = -0.5575921D-03  
 I PSZZ = -0.1924806D-03  
 G AMYZ = -0.1087530D-03  
 G AMXZ = -0.2827496D-03  
 G AMXY = 0.2744006D-03  
 SIGXX = 0.2464535D+04  
 SIGYY = -0.8991628D+02  
 SIGZZ = 0.3232583D+02  
 IAUYZ = -0.2399227D+02  
 IAUXX = -0.1666695D+03  
 IAUXY = -0.5782181D+03

COORDINATES OF OUTPUT POINTS  
 Y = -0.2400000D+00  
 Z = 0.3750000D-02  
 STRAIN ENERGY = 0.1199760D+01

I PSXX = 0.1000000D-02  
 I PSYY = -0.5100366D-03  
 I PSZZ = -0.1997845D-03  
 G AMYZ = -0.3644561D-04  
 G AMXZ = -0.9196529D-04  
 G AMXY = 0.3026572D-03  
 SIGXX = 0.2421688D+04  
 SIGYY = -0.1039724D+03  
 SIGZZ = 0.3684504D+02  
 IAUYZ = -0.8504986D+01  
 IAUXX = -0.5440311D+02  
 IAUXY = -0.5136180D+03

\* ELEMENT ( 36 ) STRESSES, STRAINS AND STRAIN ENERGIES PER UNIT VOLUME EVALUATED AT POINT (5) \*

COORDINATES OF OUTPUT POINTS  
 Y = 0.2400000D+00  
 Z = 0.1250000D-02  
 STRAIN ENERGY = 0.1160152D+01

5		10	15	24	33	42
4	1	9	5	10	9	23 21
3	2	8	6	13	12	21 23
2	3	7	7	12	15	19 25
1	4	6	8	11	20	16 28
						32 29
						31 30
						30 31
						29 32
						28 33
						27 34
						26 35
						25 36
						34

Example Problem, T300/5208, 8-Layer, (45.0,45.0,-45.0,-45.0)<sub>s</sub>  
EPSX = 0.001, Hygrothermal Load = 0.000

ORIGINAL PAGE IS  
OF POOR QUALITY

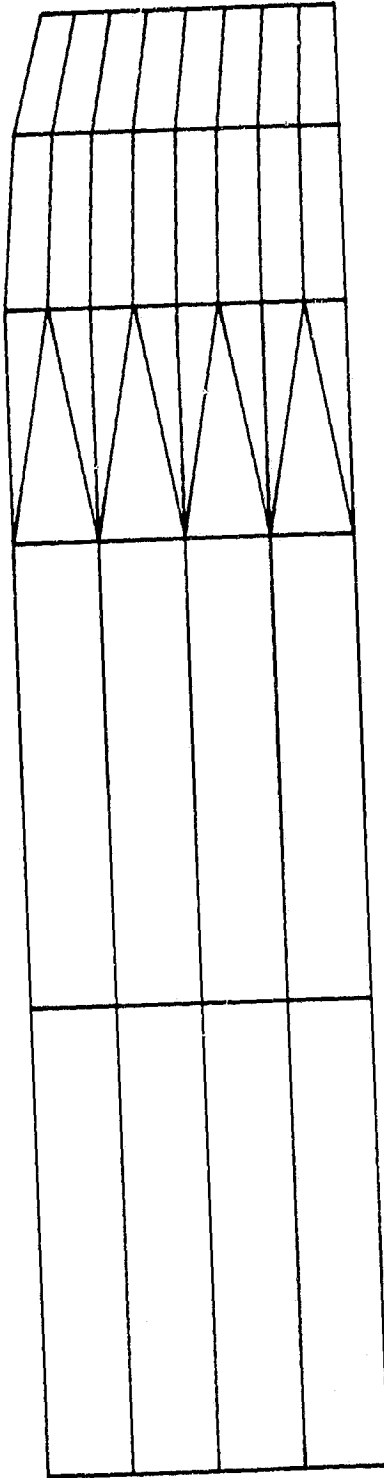

Example Problem, T300/5208, 8-Layer, (45.0, 45.0, -45.0, -45.0) s  
EPSX = 0.001, Hygrothermal Load = 0.000