

N 8 4 - 2 4 5 8 1

NASA Technical Memorandum 83641

Supersonic STOVL Ejector Aircraft from a Propulsion Point of View

R. Luidens, R. Plencner, W. Haller, and A. Glassman
Lewis Research Center
Cleveland, Ohio

Prepared for the
Twentieth Joint Propulsion Conference
cosponsored by the AIAA, SAE, and ASME
Cincinnati, Ohio, June 11-13, 1984

NASA

SUPERSONIC STOVL EJECTOR AIRCRAFT

FROM A PROPULSION POINT OF VIEW

R. Luidens,* R. Plencner,** W. Haller,** and A. Glassman†

National Aeronautics and Space Administration
Lewis Research Center
Cleveland, Ohio

Abstract

The paper first describes a baseline supersonic STOVL ejector aircraft, including its propulsion and typical operating modes, and identifies important propulsion parameters. Then a number of propulsion system changes are evaluated in terms of improving the lift-off performance; namely, aft deflection of the ejector jet and heating of the ejector primary air either by burning or using the hot engine core flow. The possibility for cooling the footprint is illustrated for the cases of mixing or interchanging the fan and core flows, and using a core flow ejector. Finally, the application of a new engine concept is presented, the turbine bypass engine plus a turbocompressor to supply the ejector primary air, and thrust during take-off and combat.

Introduction

It is generally accepted that short takeoff and vertical landing (STOVL) aircraft have an important place in the military. The British built Harrier, a subsonic aircraft, is used by Britain, Spain, India, and the U.S. Marines. The Russians also have a subsonic VTOL aircraft, the Forger, for use on small aircraft carriers.

The next generation of STOVL aircraft is expected to have at least supersonic dash capability. There are many candidate configurations for a follow-on aircraft, but four of the leading contenders¹ are shown in figures 1 and 2. They are: (1) the Remote Augmented Lift System (RALS) (which is taken to include the turbine bypass engine with turbocompressor unit),^{2, 3} (2) the Tandem or Hybrid Fan,⁴ (3) the Ejector, and (4) the Deflected Thrust System, such as, an advanced Harrier with fan air burning.

The present paper deals with the Ejector configuration,⁵ and in particular its propulsion system. The configuration to be discussed, shown in figure 2, has a delta wing with foldable ejectors through the wing adjacent to the fuselage.

In considering the propulsion system for an advanced STOVL aircraft, there are several important characteristics to be considered which form the outline for the paper:

*Deputy Chief, Advanced Programs and Planning

Office, Associate Fellow AIAA.

**Aerospace Engineer

†Head, Subsonic Missions Analysis Section.

1. Higher propulsion system thrust for greater lift-off acceleration.

2. Cooler footprint, for safer, more convenient handling, and lower observability.

3. Alternative basic propulsion cycles.

The approach of this paper is to use the aircraft of reference 5 as a baseline, and then to consider some candidate propulsion system growth options. The vehicle described in reference 5 was selected on the basis of detailed aircraft design and performance analyses. The present paper analyzes the propulsion system options from a fundamental point of view and does not involve detailed design or the evaluation of such factors as weights, aircraft-propulsion integration, and costs. Any selection from the candidate growth options will depend on further detailed studies.

Baseline Ejector Aircraft

The baseline ejector aircraft and propulsion system is described first.

Ejector Types

Even having picked an ejector type aircraft, there are five types of ejectors listed on the left side of figure 3 that could be considered. They fall into two categories: those with modest primary pressure ratios and subsonic secondary flow, and those with a high primary pressure ratio. Those with the modest primary pressure ratio are: (1) those with steady flow and fixed primary nozzles, (2) those with low speed rotating primary nozzles, and (3) those with pulsed flow primaries. Those with the high primary pressure ratio are: (4) those having supersonic secondary flow, and (5) two stage ejectors. Diffuser blowing for greater diffusion ratio or rate and acoustic enhancement of mixing might be used with any of these. The present study deals with only the first type.

Based on detailed analyses and experiments for this type of ejector, the geometric characteristics shown on the right of figure 3 were selected as giving good ejector performance or a high augmentation ratio: (a) a 1.8:1 ejector exit to throat area ratio, and (b) a diffuser wall half angle of 8 degrees. This yields a secondary to primary mass flow ratio, m_s/m_p , of about 10 for equal primary and secondary flow densities, and an augmentation ratio, ϕ_{ej} , of about 1.7.

Even with a high subsonic throat Mach number, the thrust per volume of the ejector is low and the drag associated with its volume is generally inconsistent with supersonic flight. This problem is overcome by assuming the ejector walls are foldable to eliminate the diffuser volume. A key performance parameter of the ejector then becomes the thrust per throat area. For the case of the ejector in the wing, a large value reduces the hole size that must be cut through the wing.

Aircraft Operation

Because the purpose of the paper is to discuss the propulsion system, it is important to review how it operates during a typical flight. This is illustrated in figure 4.

STO Ground Run, sketch 1: For the short take-off, e.g., 400', the core air is directed rearward, and the fan air is burned in the fan air aft duct and also directed rearward. This, of course, is to achieve maximum axial acceleration. The aircraft is at near zero angle of attack, and the ejector is deployed ready for operation.

STO Lift Off, sketch 2: At lift off the fuel to the fan air burner is shut off, but a small quantity of fan air may be still exhausted rearward to keep the aft duct clear of residual fuel. The main quantity of fan air is directed forward, by a valve, to the ejectors. The ejector force must pitch the aircraft nose up to 18° to 20° angle of attack to generate wing lift in addition to the ejector lift. The core nozzle is deflected downward about 45° to provide lift and thrust to overcome the aircraft and ejector drags. This is discussed in more detail later.

Subsonic Cruise, sketch 3: For subsonic cruise, both the fan flow and core flow are directed rearward. The fan air is not afterburned and the engine is at part throttle. The ejector is now folded in contrast to the case at takeoff.

Supersonic Cruise and Combat, sketch 4: The fan and core jets are directed rearward, and the fan air is afterburned for supersonic cruise and combat.

Vertical Landing, sketch 5: The fan is ducted to the ejector whose jet is 90° to the aircraft longitudinal axis, and the core air is also deflected down 90°. A higher deflection may be needed during approach to aid in aircraft deceleration. The ejector ram drag is helpful in this case.

Basic Ejector Propulsion Parameters

We begin with a discussion of some basic ejector propulsion system parameters relevant to the baseline ejector aircraft and ejector aircraft in general before discussing some potential growth system options.

Three propulsion system parameters of importance to a supersonic ejector aircraft are: (1) the ejector thrust per unit throat area, (2) the

ejector thrust per unit fan plus ejector ducting frontal area, and (3) the thrust per unit volume of the propulsion system. Each of these will be discussed.

Thrust Per Ejector Throat Area

Figure 5 shows a typical ejector layout in a delta wing. The purpose of this ejector is two fold: (1) to augment the basic fan thrust (the fan flow is the ejector primary flow) to provide lift, and (2) to provide an airplane nose-up pitching moment about the aircraft center of gravity (c.g.) for aircraft trim.

The ejector throat area to wing area ratio, A_t/S_w , is related to other aircraft and engine characteristics by the relation

$$(A_t/S_w) = \frac{(W_G/S_w)}{(F_{fn}/F_{tot})} \frac{(F_{tot}/W_G)}{\phi_0} \frac{1}{(1/F_{ej}/A_t)}$$

The terms in this relation are defined below and typical values are listed.

Term:	Typical Value:
W_G/S_w = aircraft wing loading, lbs/ft ²	60
F_{tot}/W_G = aircraft thrust loading	0.8
F_{fn}/F_{tot} = fan to total thrust split	0.31
$\phi_0 \equiv F_{ej}/F_{fn}$ = overall ejector augmentation ratio	1.5
F_{ej}/A_t = ejector thrust to throat area ratio, lbs/ft ²	300
A_t/S_w = ejector throat to wing area ratio	0.7

This relation shows that a high ejector thrust per unit of ejector throat area, F_{ej}/A_t , will reduce the area cut through the wing structure A_t/S_w . A reduced ejector throat area will also permit the moment arm to the center of the ejector thrust, x_{cg} , to increase, thus increasing the ejector pitching moment capability.

Figure 6 shows the results of a simple analysis of a steady flow ejector. Figure 6a shows that higher thrusts per unit throat area are achieved by high, subsonic, secondary flow throat Mach numbers.

Figure 6b relates the secondary flow throat Mach number to the ejector primary pressure ratio and temperature. Increasing the primary pressure ratio, especially up to values of about 4 is important, but increasing primary flow temperature is also important. The increase in secondary throat Mach number with primary gas temperature assumes the primary nozzle size increases with temperature, and that the secondary flow geometry remains constant. (A later discussion considers the case of no primary or secondary geometry change.) The dotted line, for example, shows a primary nozzle

pressure ratio of 3, a primary gas temperature of about 800°R yielding a secondary flow Mach number of about 0.5 and a corresponding $F_{ej}/A_t = 300$ lbs/sq ft. In the baseline case, the ejector primary pressure is provided by the engine fan. The source of the hot primary temperature will be discussed later

The pitching moment an ejector of a given throat area will produce depends on its length to width ratio, l/w . Typical results for $A_t/S_w = 0.07$ are shown in figure 7. An l/w of about 3.5 yields the maximum pitching moment although the maximum is flat. A larger l/w , say 5, reduces the blockage that the ejector discharge causes to the free stream air flowing under the wing with little reduction in pitching moment from the optimum.

The sketch in figures 5 and 7 has an $A_t/S_w = 0.07$ and an $l/w = 5.0$.

Thrust Per Fan Plus Duct Frontal Area

For an aircraft to have supersonic capability, a low frontal area of the aircraft, which consists in part of the propulsion system frontal area, is very important. So an important propulsion system parameter is the thrust per propulsion system frontal area. For the ejector system, the frontal area shown in figure 8 is made up of that part of the fan frontal area that provides the ejector air, A_{fn} , plus the frontal or cross sectional area of the duct, A_d , which in the assumed aircraft, passes over the fan to deliver the fan air to the ejector

The cross sectional area of the duct is determined by the mass flow in the duct, and the duct flow Mach number, M_d , which in turn is a function of the fan pressure ratio, FPR. The choice of duct Mach number is also related to the total pressure losses in the duct which generally increase with the duct Mach number squared. The duct losses are also proportional to the number of duct turns, which in this case is the primary source of the losses. The baseline ejector system being considered has four, 90° turns, illustrated in figure 8: (1) from the aft axial direction exiting the fan to upward, (2) from upward to forward in the duct passing over the fan, (3) from forward in the fuselage duct to outboard into the wing where the ejector is, and (4) from outward to downward as required to serve as the downward thrusting ejector primary

The results of an analysis of such a system are shown in figure 9. In figure 9a, $F_{ej}/(A_{fn} + A_d)$ is plotted versus fan pressure ratio for several values of duct Mach number. A large value of the ordinate is desirable. The curves show increasing $F_{ej}/(A_{fn} + A_d)$ with increasing fan pressure ratio for all duct Mach numbers. The effect of the duct loss may be seen for a $M_d = 0.2$ by comparing the dashed line, which has no losses with the solid line which has the duct turning losses included. The duct Mach number optimizes between $M_d = 0.2$ and 0.3. Higher duct Mach numbers reduce the duct cross sectional area, which is favorable, but also increase the losses which causes a decrease the thrust, which is unfavorable. The trade-off between these two effects results in an optimum duct Mach number

Figure 9b presents the corresponding ejector thrust divided by the fan shaft energy input, F_{ej}/E . A high value corresponds to a reduced fuel consumption rate. Since the takeoff and landing times are short, there is only a small quantity of fuel involved. In any case, for fan pressure ratios between 3 and 4, there is not an important variation in F_{ej}/E with fan pressure ratio or duct Mach number

Thrust Per Propulsion Volume

The volume taken up in the fuselage by the propulsion system is not available for payload or fuel, so a low volume propulsion arrangement is desirable. Figure 10 shows two possible aircraft arrangements. For both, the engine is near the center of the aircraft and provisions are made for the fan air collection and ducting to a forward ejector for takeoff and landing. In the upper figure, in the cruise mode, the fan air is ducted to, and exhausted at the rear of the aircraft. This ducting occupies considerable fuselage volume. In the lower figure, in the cruise mode, the fan air nozzle is adjacent to the core nozzle. Alternatively, the fan and core air could be mixed and exhausted through a common nozzle near the airframe center. This reduces the propulsion system volume, but aggravates the fuselage angles in the vicinity of the nozzles. A detailed study is needed to resolve such questions

Subsequent discussions will deal with these geometric arrangements to achieve other objectives

Ejector Propulsion Options

Having presented the baseline ejector aircraft and some basic ejector propulsion parameters, the following discussion deals with ways the propulsion system can be modified to yield greater thrust performance, a cooler footprint, or benefit from alternative propulsion cycle and then categorizes these modifications from a cycle point of view.

Greater Performance

Ejector Jet Deflection: Consider the possibility of improving the aircraft performance at lift-off, figure 11. The base aircraft at lift-off conditions is shown in figure 11a. The ejector jet, F_{ej} , is normal to aircraft longitudinal axis, $\delta = 0$, and the lift-off is assumed to occur at an aircraft angle of attack, $\alpha = 20^\circ$. The core jet, F_{cr} , is also deflected downward to provide both lift and thrust, and to balance the aircraft pitching moments. Variations from the baseline are shown in the other two figures. Figure 11b shows the ejector jet deflected rearward so $\delta = 40^\circ$. Figure 11c shows the wing with trailing edge blowing so the desired lift coefficient can be achieved at $\alpha = 0^\circ$.

The forces on an example airplane, (selected to illustrate the point of the discussion) i.e., lift, L ; drag, D ; and thrust, F , as a fraction of the airplane gross weight, W , are shown in figure 12 as a function of the forward velocity, V .

In figure 12a, lift-off can occur when $L/W = 1.0$. At the lift-off velocity, about 110 fps, the wing, the ejector, and deflected core jet each provide about 1/3 of the lift. Wing supported flight can occur at about 225 fps

The drag, figure 12b, is made up of the airframe drag, plus the engine core air ram drag, plus the ejector ram drag. The available thrust is made up of the core thrust from the deflected core jet and the reverse thrust of the ejector, reverse because it is blowing forward at an angle corresponding to the aircraft angle of attack, $\alpha = 20^\circ$. A minimum level of T/W above D/W , of about 0.06, is required for aircraft axial acceleration. With no ejector deflection, $\delta = 0$, and for the selected aircraft thrust to weight ratio, the margin of thrust over drag is unacceptable at lift-off, $L/W = 1.0$.

An obvious way to improve this situation is to deflect the ejector jet rearward, say by $\delta = 40^\circ$, which then yields a forward thrust component equal to that which was the reverse thrust component and the same lift. The margin of aircraft thrust over drag at lift-off is now significantly improved, it is about 0.2 g's, a much more desirable level.

The above discussion raises several questions:

1. Is the effective ejector jet angle set only by the geometry of the ejector or is it significantly affected by the external flow field at lift-off? This needs to be determined experimentally.

2. Can an ejector be designed with a variable deflection capability with little loss in ejector augmentation ratio? This also requires experimental study.

Another approach illustrated in figure 11c is to generate the wing lift at near zero angle of attack by wing trailing edge blowing and thus eliminate the ejector reverse thrust effect. However, there would still be an aircraft acceleration advantage to some aft deflection, e.g., $\delta = 20^\circ$, of the ejector jet.

Ejector Primary Air Heating Plus Aft Fan Air Burning: Another way to improve the lift-off performance is to heat the primary air for the ejector, see figure 13.

The baseline ejector system uses unheated fan air when the ejector is used, figure 13a, but an aft duct burner is used at other times as described earlier in the discussion of figure 4.

Before proceeding with discussing this option, it is interesting to note that in principle, primary air heating can be done with no change in ejector geometry, either primary nozzles or secondary flow geometry. This assumes that the primary nozzle pressure ratio remains constant (i.e., negligible total pressure loss due to combustion), that it is sufficient to choke the primary nozzle throat (generally the case), and the ejector augmentation ratio remains constant (i.e., the primary and secondary mixing are adequate). When the primary jet is heated

by a temperature ratio of $\theta \equiv T_b/T_{no b}$ and the pressure ratio remains constant, the ejector primary exit Mach number remains constant, but the exit velocity (v) increases by $\sqrt{\theta}$ because the speed of sound increases by $\sqrt{\theta}$. The flow density decreases by θ so the mass flow rate per unit area (\dot{m}), which is the product of velocity and density, decreases by $\sqrt{\theta}$. The primary thrust, $\dot{m}v$, is then independent of θ and so is the ejector thrust if the augmentation ratio remains constant. In summary, increasing the primary air temperature at constant total pressure does not affect the primary or ejector thrusts, but reduces the primary mass flow rate by $\sqrt{\theta}$.

Now, if the ejector primary air temperature is increased, for example, by a factor $\theta_{pr} = 4$, as by a burner as shown in figure 13b, the primary mass flow from the fan to the ejector is reduced to half. The other half of the mass flow from the fan is assumed to discharge through the aft fan air duct, also shown in figure 13b, and can be augmented by burning by a ratio of 2, corresponding to $\theta_{ad} \sim 4.0$. The numerical values on the figure are based on the sum of the fan and core thrusts being 100% and an example engine with a fan to core thrust split of $F_{fn}/F_{cr} = 0.45$. The values in the boxes indicate the possible percent thrust augmentation. The example in figure 13b shows a 31 percent thrust augmentation.

An alternative way of heating the ejector primary air is by mixing it with the core flow, as illustrated in figure 13c.

In the limit, for the same fan to core thrust split used above, all the ejector primary air could be core flow, figure 13d. The fan flow exiting the fan air nozzle can be burned, yielding a thrust augmentation of 31 percent.

One of the advantages of using the core air for the ejector and in the aft duct, as in figure 13d, can be understood by considering the take-off sequence of events. For acceleration down the runway, the hot core air is directed rearward in the aft duct. The fan air is directed rearward by the lower variable deflection nozzle. The fan air can be burned. The burning is initiated at the start of the ground run and continues through lift-off and transition to wingborne flight. At lift-off, most of the core flow is directed to the ejector, and the burned fan flow is deflected downward by the lower variable deflection nozzle. This system avoids the burner light required at lift-off by the systems indicated by figure 13b, for the burning of the fan ejector primary air, and in figure 13c for the burning of the fan air exiting the variable deflection core nozzle.

In comparing the options for heating the ejector primary air, fan air burning, figure 13b, or use of the hot core flow, figure 13d, for the present example, they both give the same thrust augmentation, but the use of the core air appears simpler from an engine point of view but not necessarily from an aircraft integration point of view.

Figure 14 presents the thrust augmentation for the ejector primary air burning option of

figure 13b in a more general way. It presents the ejector primary air thrust augmentation ratio as a function of the burning temperature rise. The example condition for figure 13b is indicated by the circle symbol. An important point from this figure is that the thrust augmentation varies like the square root of the temperature rise, that is, the initial increment of heat addition gives the larger thrust augmentation.

The effect on takeoff performance of burning the primary air to $\Theta_{pr} = 4$ in a propulsion system like 13b, in an aircraft like that of figure 11a, is shown in figure 15. At the 20° lift-off angle of attack, the jet out the rear of the aircraft, which does not exist in the baseline case at lift-off, provides some lift which reduces the lift-off speed as shown in figure 15a. This results in a lower drag at lift-off, figure 15b. The aft jet also provides large amount of thrust so that the thrust over drag margin is significantly improved over the baseline case, figure 15b.

In summary, two techniques for improving lift-off performance have been discussed: (1) ejector jet aft deflection at lift-off, and (2) heating of the ejector primary air by burning or by using engine core flow. Both offer significant lift-off thrust enhancement, but at the expense of increased complexity, and probably weight.

Next, we will consider cooling the footprint

Cooler Footprint

One of the advantages of the baseline ejector system over some of the other STOVL concepts is the cool, low velocity, front footprint generated by the ejector. The subject of this discussion and figure 16 are some of the possibilities for reducing the temperature of the aft or core footprint of the baseline aircraft, figure 16a.

Ejector Primary Air Burning and Fan and Core Air Mixing: In the preceding section it was pointed out that if the fan air going to the ejector primary is heated by a temperature ratio of 4, then half of the fan air is available for other purposes. For the present purpose, the cooler primary air can be mixed with the core flow, figure 16b, to reduce the jet temperature from 1500°F to 1100°F. This method yields improved lift-off performance, but also a small increase in the ejector jet temperatures for the reduction in core jet temperature.

Ejector Primary From Core Jet: Another approach which was discussed in the preceding section, figure 13d, which can also be used to reduce the jet temperatures, is to use the engine core jet for the ejector primary flow; and the cool, unburned fan flow for the aft jet, figure 16c. The aft jet is now quite cool, 280°F, and the ejector jet average temperature is 140°F, compared with 1500°F for the original core flow, figure 16a. This gives one of the coolest arrangements.

The disadvantages of this arrangement are the hot core flow ducting, and that the warmer

temperatures that are now forward are more likely to be ingested by the engine inlet.

Second Ejector for the Engine Core Flow: A direct approach to cooling the core flow is to add a second ejector around the core flow, figure 16d. Its primary purpose is to cool the jet and secondarily to augment its thrust. Such an ejector was discussed in reference 6. It may reduce the core temperature from 1500°F to 900°F, for example.

The XfV-12A System: In this system⁷ the fan and core air are first mixed, thus cooling the core flow and then the entire engine flow becomes the primary flow for ejectors so the primary temperature is further reduced by the ejector secondary flow.

Figure 17 shows how the ejector and mixed core exhaust flow temperatures vary with the ejector primary air burning temperature rise for the engine arrangement of figure 16b. As with the thrust augmentation, the initial increments in primary air burning result in the larger mixed core flow temperature reductions.

In summary, the baseline ejector system has the advantage of a cool front footprint. Two of the schemes discussed result in slightly higher front footprint temperature to reduce the aft footprint. Adding a second ejector on the core jet for cooling it, maintains the cool baseline front footprint temperature. The XfV-12A system of mixing the fan and core flows and using all this flow as the primary flow for ejectors probably results in the lowest average temperature.

Propulsion Cycles

There appears to be three categories of propulsion cycles, shown in figure 18, of primary interest for ejector propulsion systems. All the engines discussed thus far are two-spool turbofan engines, figures 18a, b, and c. Figure 18d is the newest and most unique of the engine cycles.

Separate Fan and Core Flow: In the baseline system, figure 18a, the fan and core flows are always separate. This gives the greatest freedom to optimize the choice of fan pressure ratio and engine bypass ratio. It may also require the greatest propulsion system volume in the aircraft if it requires the fan air aft duct, shown in figure 10a.

An alternate arrangement that maintains separate fan and core flow is to duct all the core flow to the ejector or out the aft duct, figure 18b. The engine cycle must be selected to yield desirable ejector primary flow characteristics. The fan air is always exhausted through a variable deflection nozzle on the underside of the aircraft, so the fan and core flows always remain separate.

Separate/Confluent Fan and Core Flow: In this scheme, figure 18c, the fan and core flows are separate during ejector operation, but are confluent during the takeoff ground roll, and during up-and-away operation. This system reduces the core exhaust temperature when the two streams are mixed, and reduces the propulsion system volume on the aircraft.

Its cycle optimization may be restricted by the requirement for core and fan static pressure matching during confluent operation, and the problem of low body surface angles for low supersonic drag may be aggravated.

Another option is to keep the core and fan flows separate even though exhausting adjacently.

The above systems all require two spool turbofan engines. The following system is single spool.

Turbine Bypass Engine and Turbocompressor Stage: The turbine bypass engine, references 2 and 3, figure 18d, is a single spool engine like a turbojet, but is characterized, typically, by 15 percent compressor bleed at a compressor pressure ratio of about 16 at full throttle at takeoff or landing condition. This bleed air can be used to drive a turbocompressor unit, TC, figure 18d, which produces flow at a pressure ratio of 3.5 to 4.0 which in turn may be used as the primary air for the ejector. When not used for the ejector, the TC jet can be used for acceleration during the ground roll and for combat maneuvers. This is a relatively new concept and needs further evaluation.

Concluding Remarks

The initial discussion shows the baseline ejector aircraft prefers high pressure ratio fans, FPR = 3.5 to 4.0, and can benefit from an increase in primary air temperature. Beyond this, there are a number of options for growth or advancement in aircraft characteristics over those of the baseline, but usually at the expense of increased complexity and possibly increased weight.

Improved aircraft lift-off performance can be obtained by: (1) adjustable ejector jet aft deflection and (2) ejector primary air heating by burning or the use of the hot core flow.

Cooler aft, or core, footprints can be approached in a number of ways, for example, (1) by mixing or displacing the hotter core flow with the cooler fan flow, or (2) by a core air cooling ejector.

The single-spool turbine bypass engine with turbocompressor unit which provides air at the desired pressure for the ejector primary and thrust for combat maneuvers is an alternative to the twin-spool fan engine.

Finally, the baseline delta wing-ejector configuration is a valuable, relatively simple, starting point for many possibilities for enhanced performance, cooler footprints, and advanced engine cycles.

References

- 1 Kidwell, G. H., Jr and Lampkin, B. A., "An Evaluation of Supersonic STOVL Technology," AIAA Paper 83-2493, Oct 1983

- 2 Sheridan, A. E., "The Application of Turbine Bypass Engines to High Performance V/STOVL Aircraft," AIAA Paper 83-2512, Oct. 1983
- 3 Franciscus, L. C., "Supersonic STOVL Aircraft With Turbine Bypass/Mass Flow Amplifier Engines," AIAA-84-1403, June 1984
- 4 Zola, C. L., Wilson, S. L., III, and Eskie, M. A., "Tandem Fan Applications in Advanced STOVL Fighter Configurations," AIAA-84-1402, June 1984
- 5 Foley, W. H., Sheridan, A. E., and Smith, C. H., "Study of Aerodynamic Technology for Single-Cruise-Engine V/STOVL Fighter/Attack Aircraft," NASA CR-166268, Feb. 1982
- 6 Willis, W. S., Konarski, M., and Sutherland, W. V., "Conceptual Design, Evaluation and Research Identification for Remote Augmented Propulsive Lift Systems (RALS) With Ejectors For VTOL Aircraft," General Electric Co., Cincinnati, OH, R82AEB315, May 1982 (NASA CR-167906)
- 7 Braden, R. P., Nagaraja, K. S., and Von Ohain, H. J. P., "Proceedings: Ejector Workshop for Aerospace Applications," AFWAL-TR-82-3059, June 1982

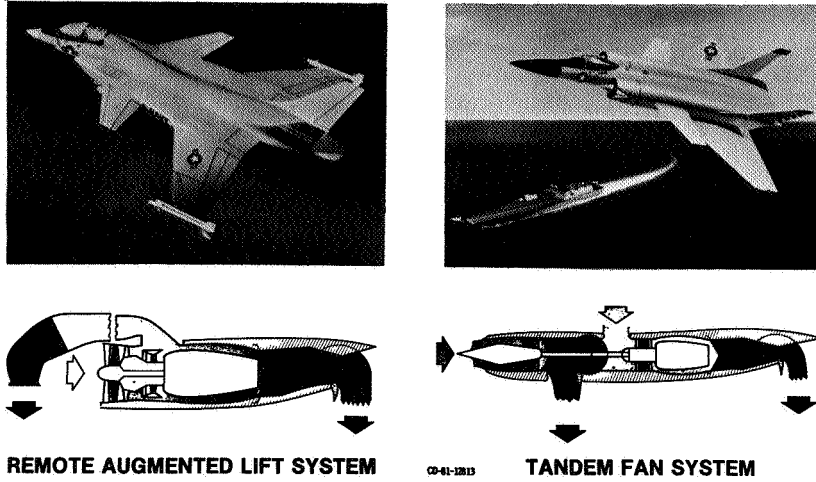

Figure 1. - Supersonic STOVL propulsion. C-82-1659

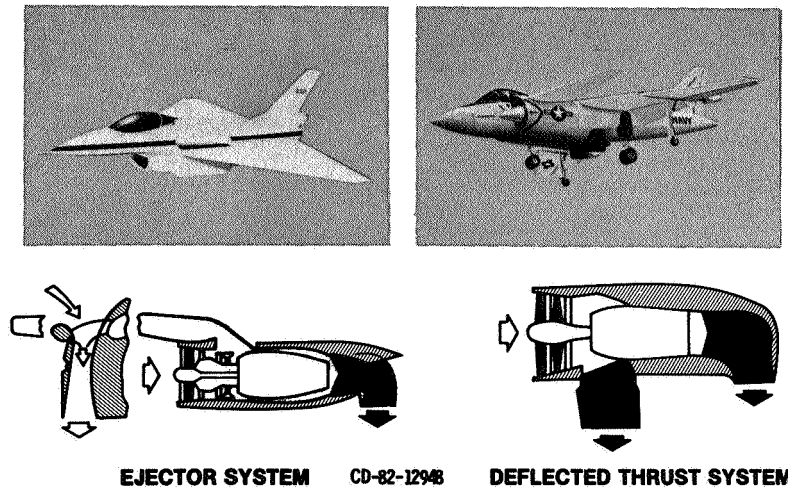

Figure 2. - Supersonic STOVL propulsion. C-82-1658

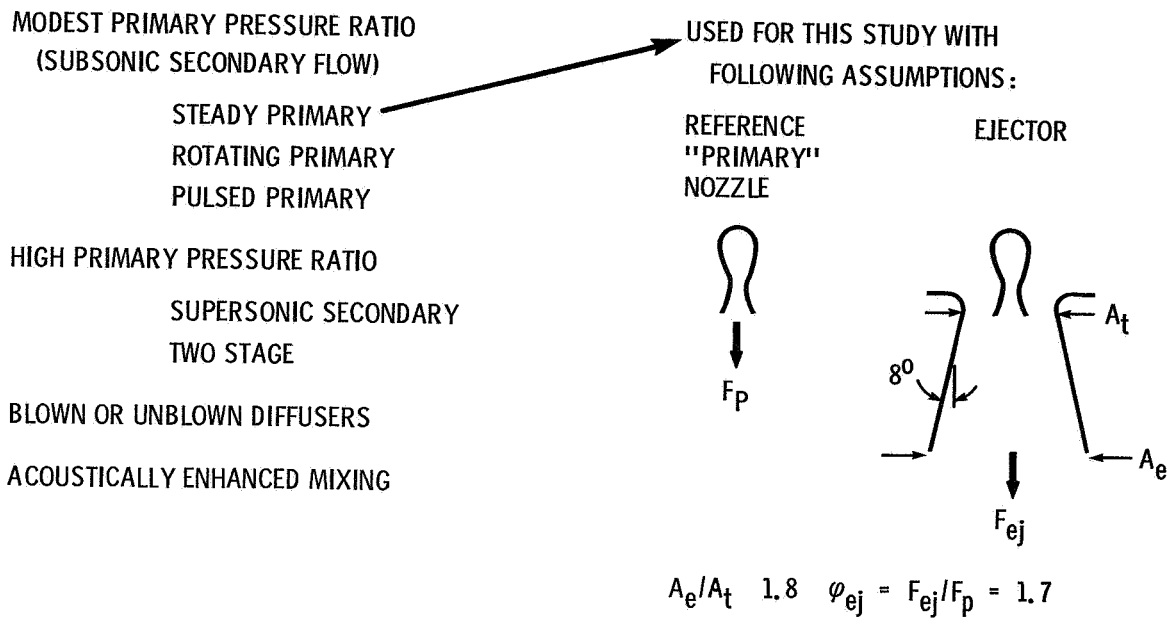

Figure 3. - Ejector types.

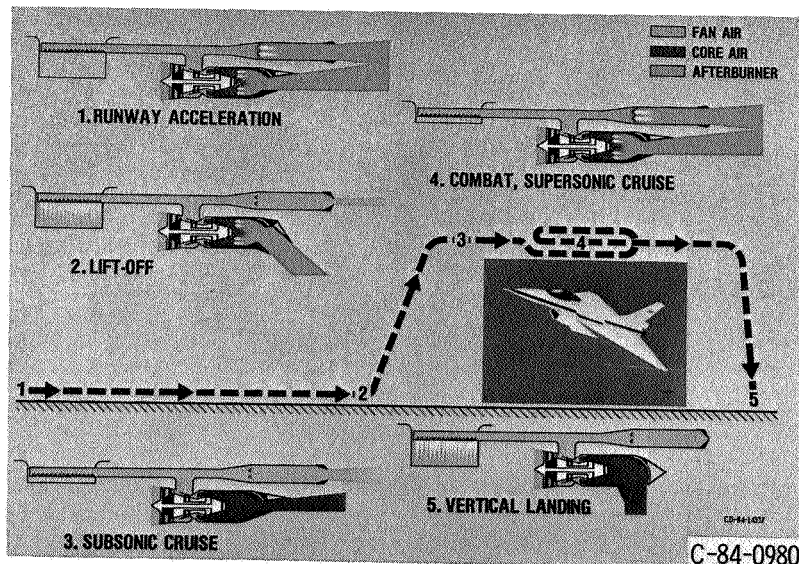

Figure 4. - Ejector propulsion modes for supersonic STOVL.

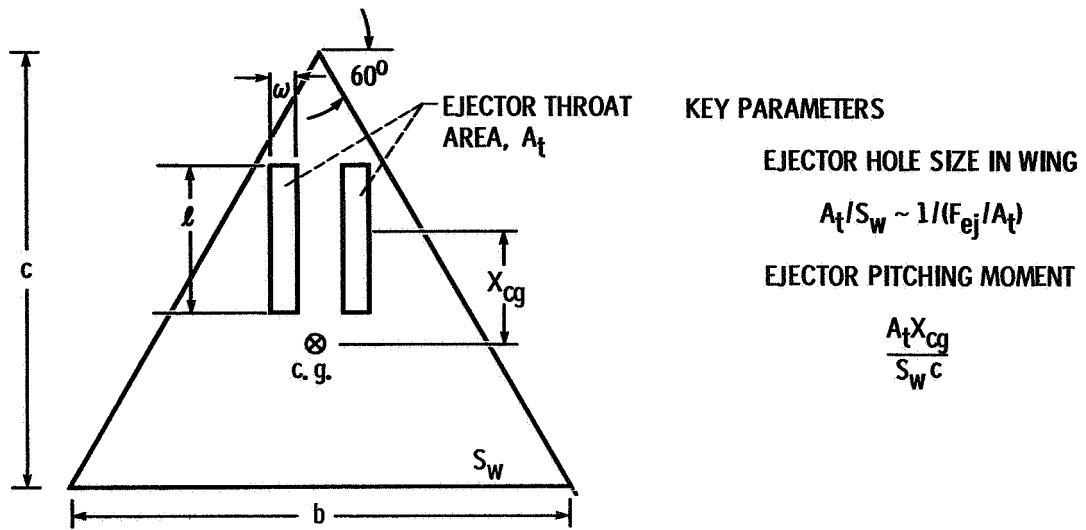

Figure 5. - Ejector and wing geometries.

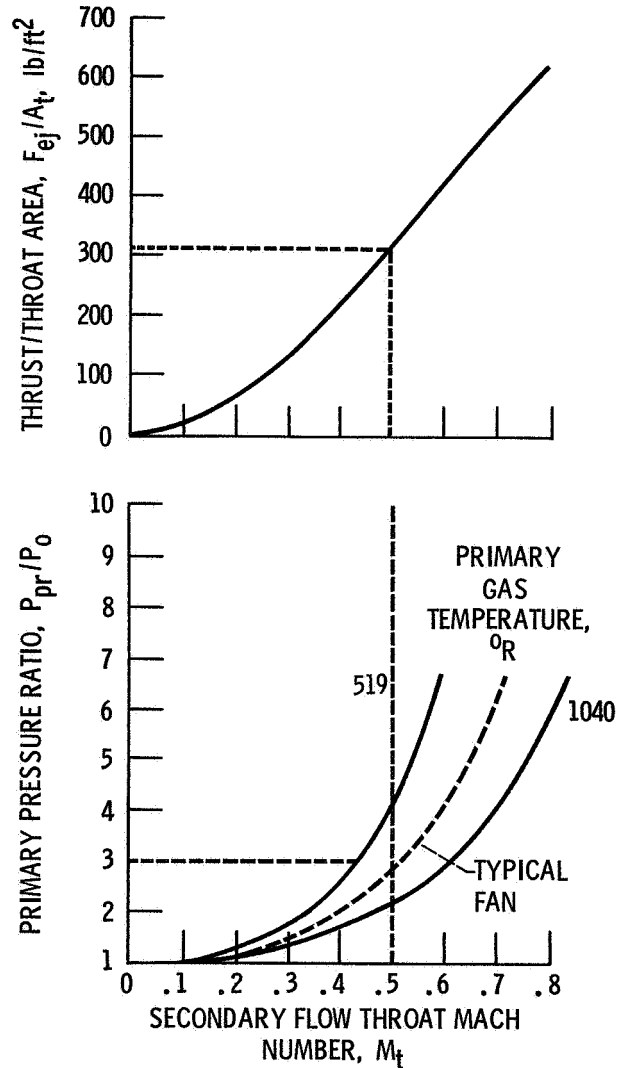

Figure 6. - Ejector thrust per throat area. Sea level static conditions.

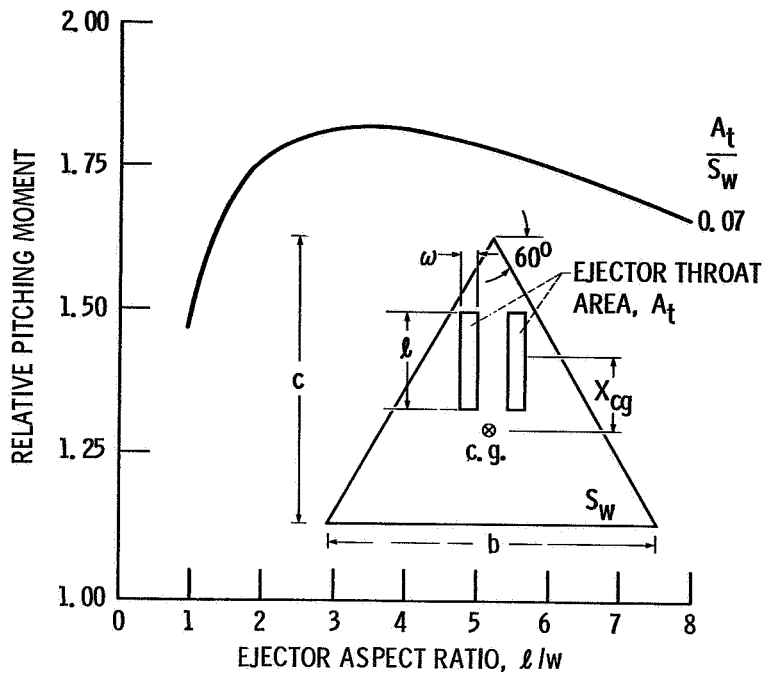

Figure 7. - Ejector pitching moments.

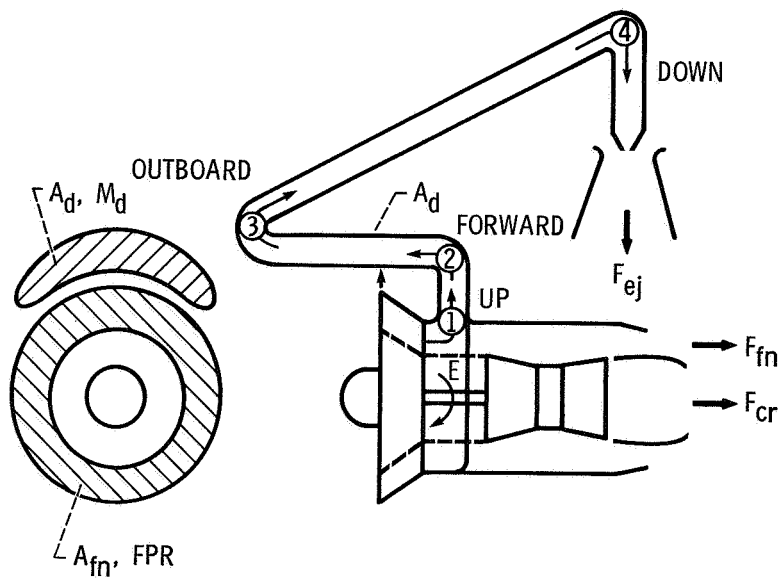

Figure 8. - Ejector propulsion system parameters.

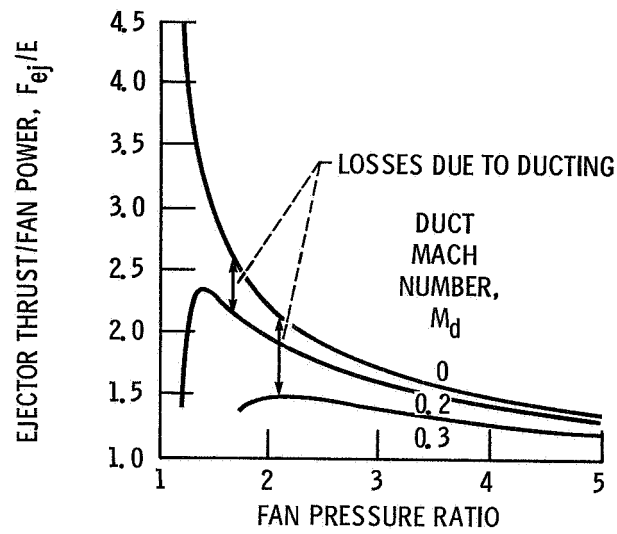
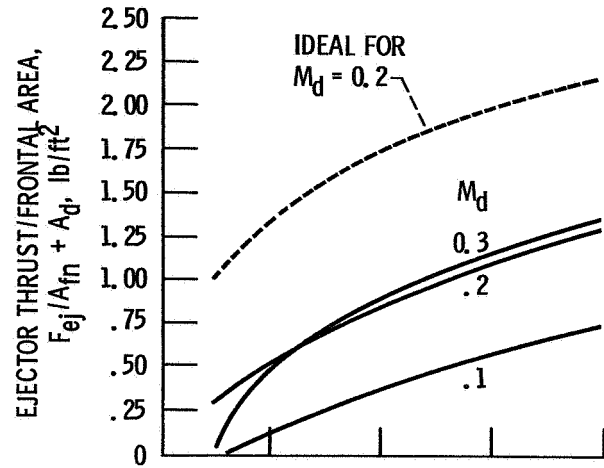
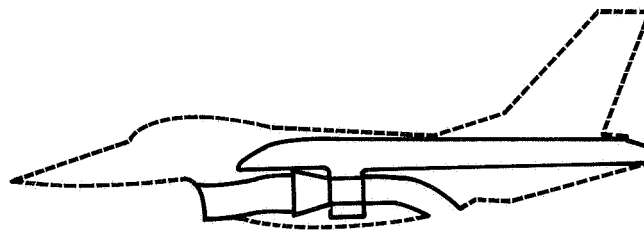
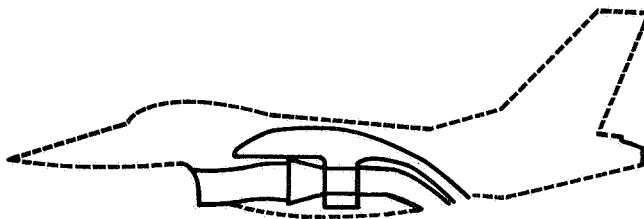

Figure 9. - Ejector thrust per frontal area and fan power input,



(a) Fan air exhausted at rear of aircraft.



(b) Fan air exhausted adjacent to core nozzle.

Figure 10. - Effect of fan air ducting on available fuselage volume.

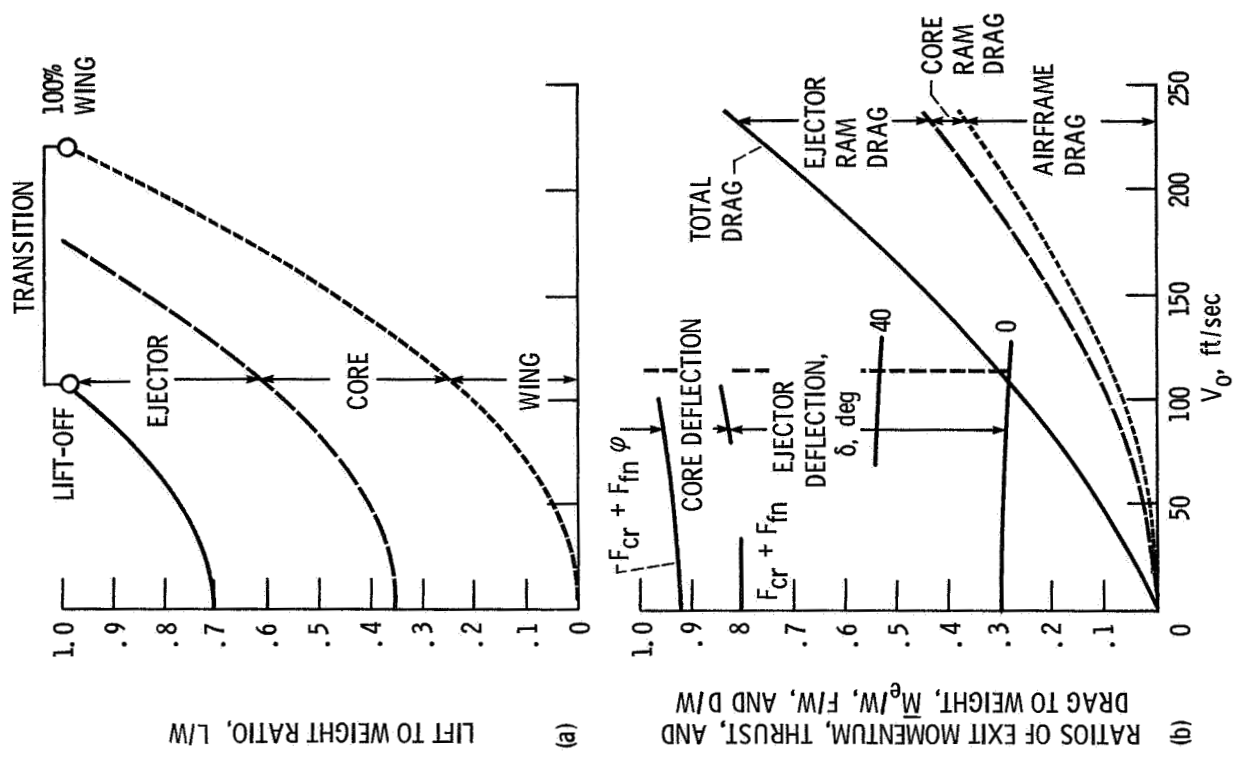
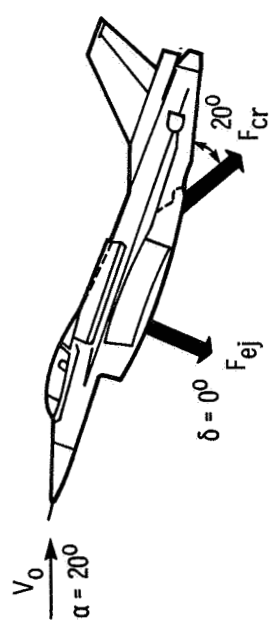
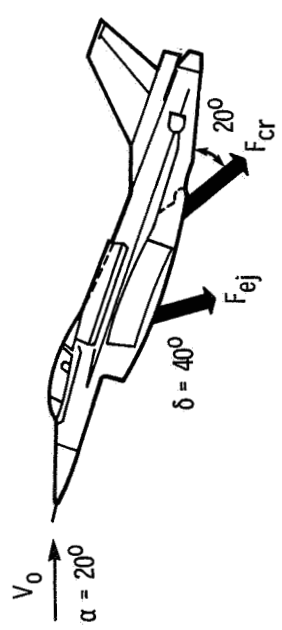

Figure 12. - Effect of ejector jet deflection on aircraft lift-off.



(a) Ejector efflux normal to aircraft longitudinal axis, $\delta = 0^\circ$.



(b) Ejector efflux deflected aft, $\delta = 40^\circ$.

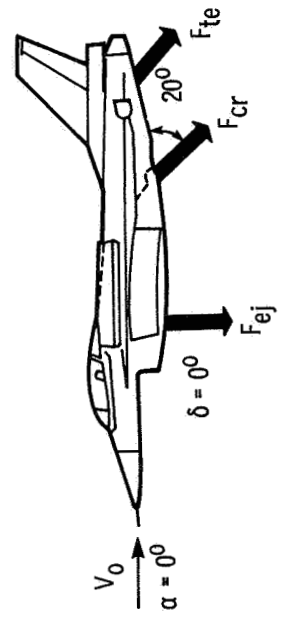

(c) Wing trailing edge blowing for $\alpha = 0^\circ$, $\delta = 0^\circ$.

Figure 11. - Ejector jet deflection at lift-off conditions.

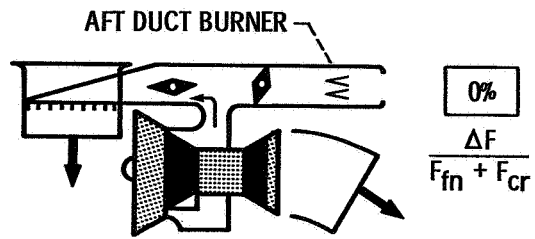

(a) Baseline, cool fan flow to ejector.

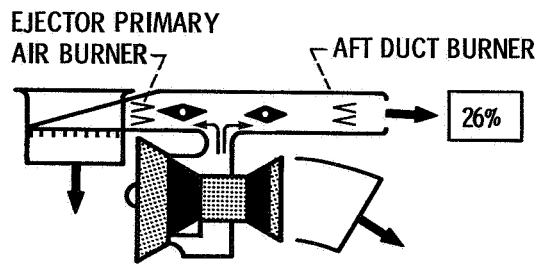

(b) Burned fan flow to ejector.

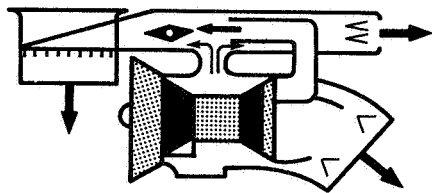

(c) Mixed cool fan flow and hot core flow to ejector.

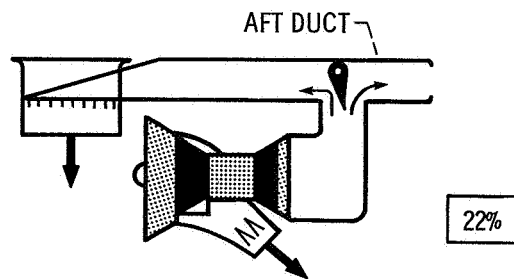

(d) All core flow to ejector.

Figure 13. - Ejector primary air heating options at lift-off conditions.

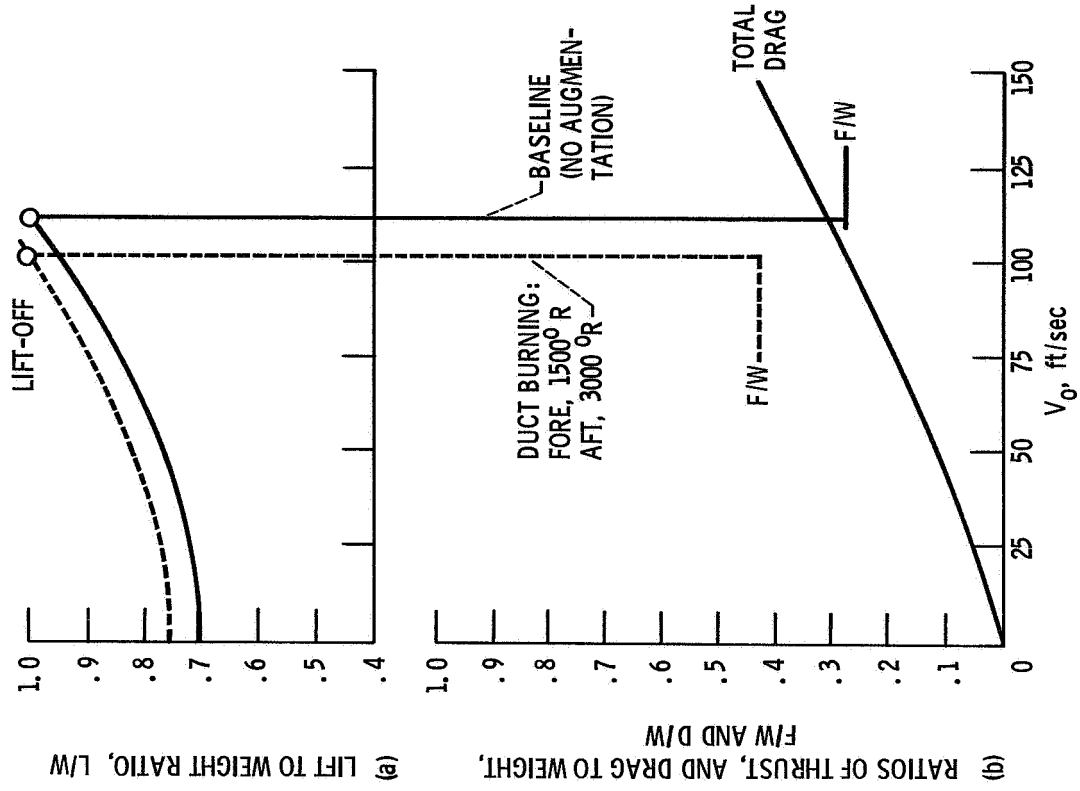

Figure 15. - Effect of ejector primary air burning on aircraft lift-off. $\delta = 0^\circ$

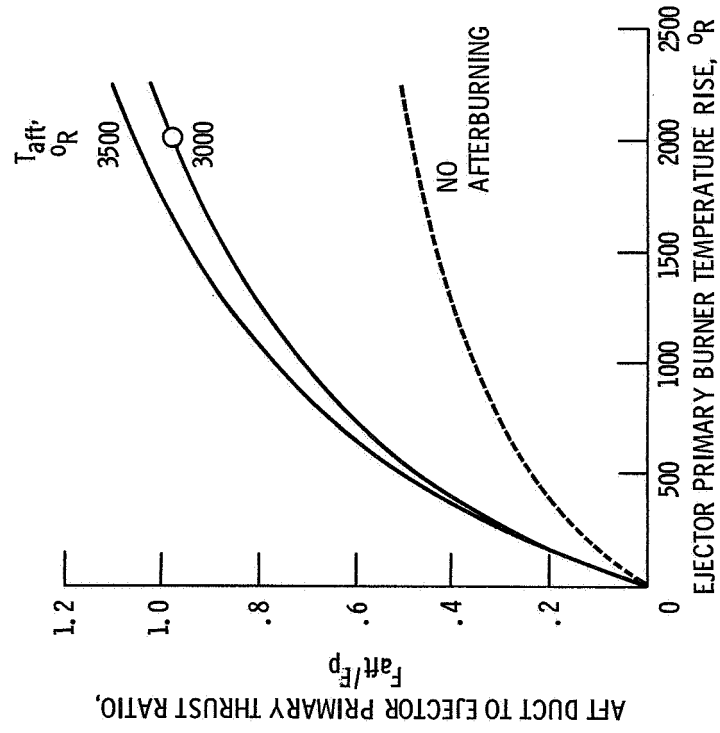
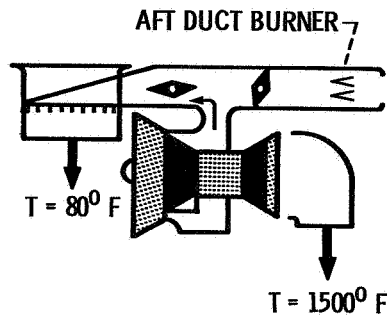
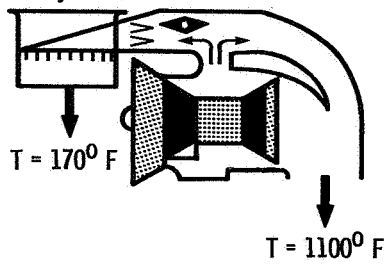

Figure 14. - Effect of ejector primary air burning on aft duct thrust augmentation.



(a) Baseline, cool fan flow to ejector.



(b) Mixed cool fan and core flows.

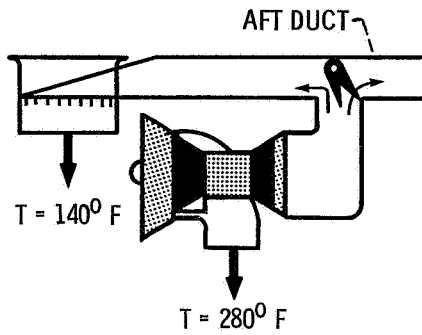

(c) All core flow to ejector

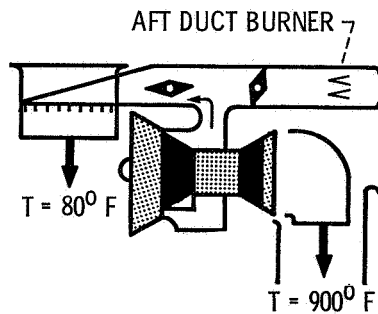

(d) Core flow cooling ejector.

Figure 16. - Exhaust jet cooling options at lift-off conditions.

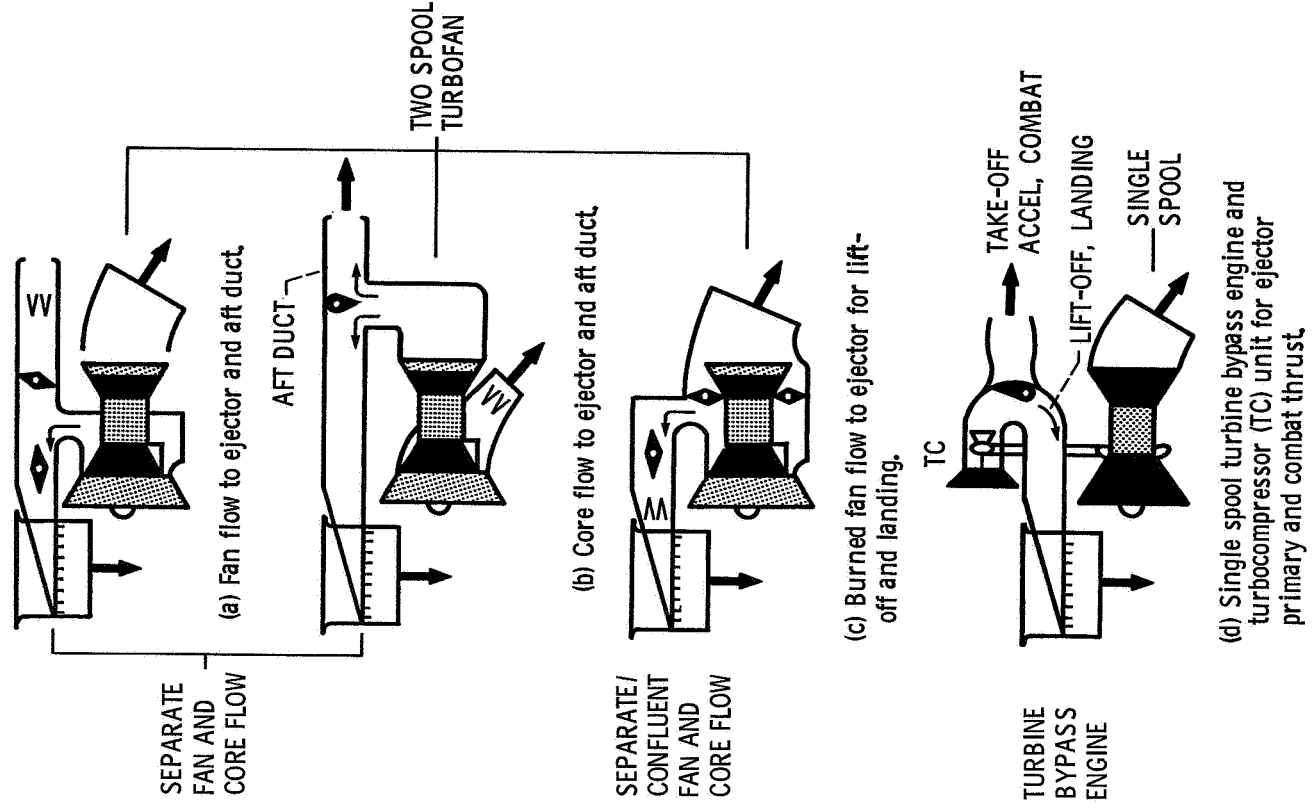

Figure 18. - Propulsion cycle categories. Shown at lift-off conditions.

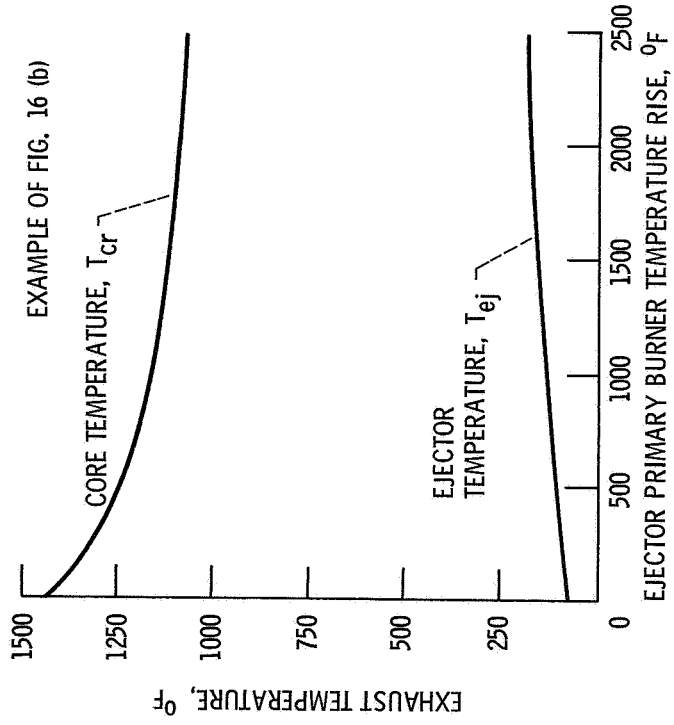

Figure 17. - Effect of ejector primary burner temperature rise on mixed exhaust jet temperature.

1. Report No. NASA TM-83641	2. Government Accession No.	3. Recipient's Catalog No.	
4. Title and Subtitle Supersonic STOVL Ejector Aircraft from a Propulsion Point of View		5. Report Date	
		6. Performing Organization Code 505-40-82	
7. Author(s) R. Luidens, R. Plencner, W. Haller, and A. Glassman		8. Performing Organization Report No. E-2084	
		10. Work Unit No.	
9. Performing Organization Name and Address National Aeronautics and Space Administration Lewis Research Center Cleveland, Ohio 44135		11. Contract or Grant No.	
		13. Type of Report and Period Covered Technical Memorandum	
12. Sponsoring Agency Name and Address National Aeronautics and Space Administration Washington, D.C. 20546		14. Sponsoring Agency Code	
15. Supplementary Notes Prepared for the Twentieth Joint Propulsion Conference cosponsored by the AIAA, SAE, and ASME, Cincinnati, Ohio, June 11-13, 1984.			
16. Abstract <p>The paper first describes a baseline supersonic STOVL ejector aircraft, including its propulsion and typical operating modes, and identifies important propulsion parameters. Then a number of propulsion system changes are evaluated in terms of improving the lift-off performance; namely, aft deflection of the ejector jet and heating of the ejector primary air either by burning or using the hot engine core flow. The possibility for cooling the footprint is illustrated for the cases of mixing or interchanging the fan and core flows, and using a core flow ejector. Finally, the application of a new engine concept is presented, the turbine bypass engine plus a turbocompressor to supply the ejector primary air, and thrust during take-off combat.</p>			
17. Key Words (Suggested by Author(s)) STOVL Ejector		18. Distribution Statement Unclassified - unlimited STAR Category 07	
19. Security Classif. (of this report) Unclassified	20. Security Classif. (of this page) Unclassified	21. No. of pages	22. Price*