

**N 84 - 2 4 5 8 7**

NASA Technical Memorandum 86040

---

# Highly Integrated Digital Engine Control System on an F-15 Airplane

---

Frank W. Burcham, Jr., and Edward A. Haering, Jr.

---

June 1984

**NASA**  
National Aeronautics and  
Space Administration

---

# Highly Integrated Digital Engine Control System on an F-15 Airplane

---

Frank W. Burcham, Jr., and Edward A. Haering, Jr.  
NASA Ames Research Center, Dryden Flight Research Facility, Edwards, California 93523

1984



National Aeronautics and  
Space Administration

**Ames Research Center**

Dryden Flight Research Facility  
Edwards, California 93523

# HIGHLY INTEGRATED DIGITAL ENGINE CONTROL SYSTEM ON AN F-15 AIRPLANE

Frank W. Burcham, Jr.\*, and Edward A. Haering, Jr.\*\*  
 NASA Ames Research Center  
 Dryden Flight Research Facility  
 Edwards, California

## Abstract

The highly integrated digital electronic control (HIDEC) program will demonstrate and evaluate the improvements in performance and mission effectiveness that result from integrated engine-airframe control systems. This system is being used on the F-15 airplane at the Dryden Flight Research Facility of NASA Ames Research Center. An integrated flightpath management mode and an integrated adaptive engine stall margin mode are being implemented into the system. The adaptive stall margin mode is a highly integrated mode in which the airplane flight conditions, the resulting inlet distortion, and the engine stall margin are continuously computed; the excess stall margin is used to uptrim the engine for more thrust. The integrated flightpath management mode optimizes the flightpath and throttle setting to reach a desired flight condition. The increase in thrust and the improvement in airplane performance is discussed in this paper.

## Nomenclature

AJ	nozzle area, ft <sup>2</sup>
ASM	adaptive stall margin
CAS	control augmentation system
D	distortion
DEEC	digital electronic engine control
DEFCS	digital electronic flight control system
DT	distortion tolerance
EMD	engine model derivative
EPR	engine pressure ratio, PT6M/PT2
Es	specific energy, ft
FADEC	full-authority digital engine control
FTIT	fan turbine inlet temperature, deg C
H	altitude, ft
HIDEC	highly integrated digital electronic control
INTERACT	integrated research aircraft technology
IPCS	integrated propulsion control system
M	Mach number
MIL-STD	military standard

\* Chief, Propulsion Section. Member AIAA.

\*\*Cooperative Student, University of Illinois. Student Member AIAA.

This paper is declared a work of the U.S. Government and therefore is in the public domain.

PLA	power lever angle, deg
Ps	specific excess power, ft/sec
PT2	fan inlet total pressure, lb/in <sup>2</sup>
PT6M	mixed turbine discharge total pressure, lb/in <sup>2</sup>
p	pitch rate
STOL	short takeoff and landing
TT2	engine inlet total temperature
UART	universal asynchronous receiver transmitter
WA	engine fan airflow, lb/sec
$\alpha$	angle of attack, deg
$\beta$	angle of sideslip, deg
$\Delta$	change in parameter
$\delta_s$	stick position
$\hat{\phantom{x}}$	estimated value

## Introduction

The benefits of full-authority digital engine controls are well known. The joint NASA/U.S. Air Force (USAF) digital electronic engine control<sup>1</sup> (DEEC) program has demonstrated large improvements in performance, operability, and maintainability. The NAVY-sponsored full-authority digital engine control (FADEC) program<sup>2</sup> developed and demonstrated control systems for advanced variable cycle engines. A full-authority digital engine control is planned for the Boeing 757 airplane. In addition, integration of the propulsion system components, and the propulsion system and the airframe has been shown to be very beneficial. The NASA USAF integrated propulsion control system (IPCS) program<sup>3</sup> integrated the engine and inlet controls on the F-111 airplane and demonstrated significant improvements in propulsion system performance and transient capability. The NASA Cooperative Control Program on the YF-12C airplane,<sup>4</sup> which integrated the inlets, autopilot, autothrottle, and navigation system, was so successful that the USAF is now equipping the SR-71 aircraft fleet with a similar system. Studies for future advanced aircraft such as the advanced technology fighter, the survivable supersonic fighter, and the short takeoff and landing (STOL) and maneuver demonstrator have all shown the need for integration of the engine, inlet, nozzle, flight control system, and the pilot.

The architecture to implement an integrated propulsion-flight control system has been studied in the NASA Integrated Airframe/Propulsion Control

System Architectures Program.<sup>5,6</sup> The design methods have been investigated in the USAF Design Methods for Integrated Control Systems Program.<sup>7,8</sup> A NASA program, integrated research aircraft technology (INTERACT)<sup>9</sup>, has studied the benefits that can be gained by integration of propulsion and flight control systems on existing aircraft; those gains have been substantial.

Of the six integrated control modes developed in the INTERACT program, the control mode with the largest performance payoff is the engine adaptive stall margin (ASM) mode, in which airframe data is used to allow the engine to operate at higher performance levels (uptrim) at times when the inlet distortion is low and the full engine stall margin is not required. It may also be desirable to obtain additional engine stall margin (downtrim) during certain flight maneuvers, such as during a STOL landing rollout with reverse thrust (where reingestion could cause an engine stall), or for extreme attitude flight in which fuselage pointing is used to fire a missile in a one-on-one, air-to-air encounter.

The second most beneficial mode identified in the INTERACT study is the integrated flightpath management mode. In this mode, the pilot could input the desired end points and the integrated logic would provide the optimum flightpath and throttle setting. The pilot can follow a display, or the system commands can be input directly to the flight controls and throttles.

Recent studies have shown that both of these integrated control modes could be implemented on the F-15 airplane. Experience with the DEEC engine controls and the development of a digital flight control system have reduced the effort required to that of manageable proportions. Therefore, the NASA Ames Research Center's Dryden Flight Research Facility, in cooperation with other government agencies, is conducting a program called highly integrated digital electronic control (HIDEC). This program will develop and evaluate new digital engine control technology that is integrated with the airplane's digital flight control system. The two integrated control modes to be implemented are an integrated flightpath management mode and an adaptive engine stall margin mode. The program plans, the results to date, and the expected benefits are presented in this paper.

#### Airplane

The NASA F-15 airplane is being used for the HIDEC program. The F-15 is a high-performance, air-superiority fighter airplane with excellent transonic maneuverability and a maximum Mach number capability of 2.5. It is powered by two afterburning turbofan engines.

#### HIDEC System

The equipment that is installed on the F-15 airplane for the HIDEC program is shown in Fig. 1. The F100 engine model derivative (EMD) involved in testing at NASA Ames Dryden<sup>10</sup> is used with the DEEC engine controllers. A digital electronic flight control system (DEFCS) is installed in the airplane and will accommodate the HIDEC computations. A

digital interface and bus control unit and a cockpit control and display are also installed. A telemetry uplink from ground-based computers is also available. The F-15 airplane is fully instrumented and equipped for propulsion and flight control integration research.

A block diagram of the HIDEC system on the F-15 airplane is shown in Fig. 2. The various digital systems on the airplane can communicate with each other via a digital interface and bus controller. This unit will permit the HIDEC system to communicate with the equipment on the F-15 H009 data bus, the universal asynchronous receiver transmitter (UART) data bus, and the military-standard (MIL-STD) 1553 bus.

The DEEC controllers on each engine will communicate with the HIDEC system via the UART bus. The normal throttle inputs to the DEEC controllers and the backup engine controls from the cockpit will be maintained.

The DEFCS is a digital implementation of the analog control augmentation system (CAS) currently on the F-15. It is a dual-channel, fail-safe, high-authority system which operates in conjunction with a mechanical flight control system. The DEFCS replaces the analog computations in the CAS and has data bus input and output capability in MIL-STD 1553 format. It is programmable in high-order language and has 80 percent excess capacity available for other control computations. For the early phases of the HIDEC program, the HIDEC control laws will be implemented in the unused portion of the DEFCS computers.

Initially, the pilot will communicate with the HIDEC system through a cockpit control and display panel. Later, a cockpit multifunction display will be added. This unit, which is being produced for the F-18 airplane, communicates on the 1553 bus. The pilot's normal stick, rudder, and throttle inputs will be handled as they are in the standard F-15 aircraft.

The NASA uplink system is also MIL-STD 1553-compatible, and can be used to provide data to the HIDEC system. This will permit control algorithms to be processed in a ground-based computer, if desired.

Most of the airframe data required by the HIDEC system is available from the equipment installed and communicating on the F-15 H009 data bus, shown at the top of Fig. 2. Included is the air data computer, the inertial navigation set, the horizontal situation indicator, the attitude and heading reference set, the central computer unit, and the navigation control indicator.

For future system expansion, an additional onboard computer can be added. This computer will be 1553-compatible, and will provide additional flexibility and computational power.

The NASA data system will monitor parameters on the 1553 bus, as well as the other parameters that are recorded directly. This data will be recorded onboard and also telemetered to the ground for real-time display, analysis, and use in control-law computations that may be uplinked to the airplane.

## Engine

The F100 EMD engine (Fig. 3) is an upgraded version of the F100-PW-100 engine that powers the production F-15 airplanes. These engines are built by Pratt and Whitney Aircraft and have a company designation of PW-1128. The engine incorporates a redesigned fan, revised compressor and combustor, single-crystal turbine blades and vanes, a 16-segment augmentor with light-off detector, and a DEEC.

The DEEC is a key part of the HIDEDEC system. It is a full-authority digital control with an integral hydromechanical backup control. It controls the gas generator and augmentor fuel flows, the compressor bleeds, the variable inlet guide vanes, the variable stators, and the variable exhaust nozzle. The DEEC incorporates logic which provides closed-loop control of engine airflow (WA) and engine pressure ratio (EPR). It also limits fan turbine inlet temperature (FTIT). It has the capability to accept inputs from the airplane and the many engine sensors.

Two computer simulations of the F100 EMD engine are being used in the HIDEDEC program: a full aerothermal, steady-state engine performance program<sup>11</sup> and a linear state-variable dynamic engine model.<sup>12</sup> The steady-state model provides accurate values for many engine parameters including engine thrust, fuel flow, fan and core stall margins, and the DEEC parameters. Its inputs are inlet pressure, temperature, and power setting.

The linear state-variable dynamic model of the F100 EMD provides reasonably realistic dynamic response characteristics for engine transients but less accurate steady-state results. The linear models are determined at several points in the flight envelope and for several power settings, and linear interpolation is used between the modeled conditions.

### Adaptive Stall Margin Mode

A simplified view of the adaptive stall margin (ASM) mode is shown in the block diagram of Fig. 4. Airframe data are used to provide not only the current angles of attack and sideslip, but also a prediction of what these parameters will be in the future. These inputs are then used to determine current and predicted inlet distortion. The inlet distortion and the engine's current stall margin is then used to generate an uptrim command. The uptrim command will be small if the distortion is near the engine's tolerance; it can be large if the distortion is very low or if the engine's stall margin is very high. The uptrim command will be converted into DEEC commands and then transmitted to the DEEC, which will move the engine variables to effect the uptrim. The many engine parameters from the DEEC will be used to determine the remaining engine stall margin, and the calculated engine airflow will be fed back to the inlet distortion calculation. Each of these functions are discussed.

### Airframe Data

The airplane flight conditions, such as Mach number, altitude, angles of attack and sideslip, pitch, roll, and yaw rates, and stick, rudder and

throttle positions are used to determine current and predicted values of angle of attack, angle of sideslip, and throttle position. Airplane dynamics are modeled and used to provide an estimate of future values to provide lead for the adaptive stall margin mode.

### Inlet Data

Using the estimates for airplane angle of attack, angle of sideslip, and the engine airflow, the inlet distortion (D) can be determined. Flight data and wind tunnel test results will be used to build the inlet data base. In general, for the F-15 airplane, the inlet distortion is relatively low over a significant part of the operating envelope. Fig. 5 shows typical values of D as a function of  $\alpha$  and  $\beta$  for the F-15 airplane inlet at a supersonic condition.

### Engine Stall Margin

The stall margin of the F100 EMD engine will be determined as a function of inlet conditions, PLA, engine parameters, and the engine's stall margin characteristics. During engine development, the fan and compressor stall margins were determined from component rig tests and engine tests over the engine operating envelope. Stability audits were conducted at many operating conditions; an example of a fan stability audit at a low-speed, low-altitude condition, and at a subsonic, high-altitude condition is shown in Fig. 6. The total engine stall margin for the low-speed, low-altitude condition includes: control tolerances, 1 percent; engine-to-engine variations, 2 percent; Reynolds number effects, 0 at this condition; augmentor transients, 5 percent; distortion effects, 9 percent; and remaining stall margin, 8 percent. The distortion effects are budgeted based on the worst case distortion expected at this flight condition. If the PLA is constant, some of the stall margin used for augmentor transients could also be used for uptrim. At the subsonic, high-altitude condition, the total stall margin is less and the required stall margin is larger; the remaining stall margin is only 3 percent.

Engine stall margin may be modified by adjusting the engine variables; for the HIDEDEC program, this can be accomplished by increasing the EPR, WA, or FTIT. EPR is increased by closing the nozzle, WA is increased by increasing the fan speed, and FTIT is increased by increasing gas generator fuel flow.

### Allowable Uptrim

Using the engine distortion tolerance and the inlet distortion values, the allowable uptrim can be calculated. For the HIDEDEC program, the distortion at the current flight condition will be compared to the distortion tolerance of the engine; the difference can be used for uptrim. Some safety margin must be maintained to allow for inaccuracies in the data used in the computations. Additional margin must be maintained during rapid airplane maneuvers. The uptrim commands also need to be smoothed to prevent sudden thrust transients that would be annoying to the crew and detrimental to the life of the engine.

## DEEC Commands

Once the uptrim request has been calculated, the DEEC commands can then be determined. Plans include providing uptrim in terms of EPR, WA, and FTIT. Limits in EPR, WA, and FTIT exist, and in some parts of the engine operating envelope, the engine normally operates on these limits. Therefore, uptrim requests which are allowable based on stall margin may not be allowable because of other engine limits.

## Adjust DEEC Control Schedules

The DEEC logic will be modified for the HIDEDEC program to accept uptrim commands of EPR, FTIT, and WA. Limits will be provided to maintain safe engine operation in case of unreasonable uptrim commands, and the normal engine limiting logic will be maintained. For example, current DEEC logic has a schedule of EPR as a function of engine inlet total temperature (TT2). For HIDEDEC, a new upper EPR schedule will be added, and EPR commands to the upper limit will be accepted. Airflow uptrim may be used in some parts of the flight envelope, but inlet airflow capability will need to be considered. FTIT uptrim may be useful in some areas of the flight envelope, but the resulting decrease in engine hot section life must be considered.

## Typical Uptrim Results

The performance gains because of uptrim have been investigated for the HIDEDEC program. The F100 EMD steady-state performance deck<sup>11</sup> has been used to determine the effects of EPR uptrim at several flight conditions. Fig. 7 shows an uptrim case at the low-speed, low-altitude condition at intermediate (maximum nonafterburning) power. As the EPR uptrim request increases, the DEEC control closes the nozzle area (AJ) until the minimum area of 2.7 ft<sup>2</sup> is reached. Thrust increases from 12,720 to 13,740 lb, while fan stall margin decreases from 25 percent to 15 percent, due to the increased back pressure on the fan. In order to maintain the scheduled fan airflow, the gas generator fuel flow has to be increased; the FTIT increases by 29° C. Based on this data and the stability audit of Fig. 6, an uptrim request of 10 percent might be practical.

Results of another uptrim case at maximum afterburning power at the subsonic high-altitude flight condition are shown in Fig. 8. Again, the requested uptrim in EPR is accomplished by closing the nozzle and increasing FTIT. The thrust increases from 4050 lb to 4585 lb, a 13-percent increase. However, at the 15-percent uptrim point, the stall margin is only 3 percent. The stability audit in Fig. 6 indicates that approximately 12-percent stall margin is required even if the distortion is low. Since the throttle is at maximum afterburning, the augmentor transient allowance (mostly required for augmentor segment-lighting pressure pulses) may not all be required. The 12-percent stall margin could be maintained with a 10-percent EPR uptrim, and with a corresponding thrust increase of 9 percent.

The simulation results generally indicate that the specific fuel consumption remains approximately constant during EPR uptrims, at least for uptrims of 10 percent or less. Therefore, for the

evaluation, it is reasonable to assume that thrust and fuel flow will increase by the same amount.

The dynamics of EPR uptrim have been investigated with the F100 linear state-variable dynamic model.<sup>12</sup> An uptrim at the low-altitude, low-speed condition is shown in Fig. 9. Prior to the uptrim ramp input beginning at a time of 0 sec, the steady-state values of thrust were slightly lower and stall margin slightly higher than results from the steady-state deck that were shown in Fig. 8. The uptrim was accomplished by closing the nozzle over a 1.1-sec period. Fuel flow was simultaneously increased to hold the fan speed constant. The response was smooth and rapid. The thrust, FTIT, and stall margin changes are similar to that indicated by the steady-state deck. The uptrim was then removed in 0.3 sec to evaluate the rapid downtrim that might be required in maneuvering flight. These results show that the engine can respond to rapid changes in uptrim request. However, the DEEC response was not modeled in these results, and the stability of the engine with the control system in the loop still needs to be investigated. A nonlinear DEEC model is being developed to improve the fidelity of the engine dynamic simulation.

Uptrim in FTIT and WA will also be used in the HIDEDEC program, but will not be discussed in this paper. The overall uptrim capability of the F100 engine was determined during the INTERACT study.<sup>9</sup> Results are shown in Fig. 10. Up to 12-percent uptrim was indicated at low Mach numbers, and 3 to 5 percent at low supersonic speeds. These results will be updated as more of the investigations outlined here are conducted.

## Flightpath Management Mode

The other mode to be implemented in the HIDEDEC program is the integrated flightpath management mode. Fig. 11 shows some of the potential flightpath management modes that may be investigated in the HIDEDEC program. These include the trajectory optimization routines that provide optimizations for minimum time and fuel, and maximum range and endurance. Later, these may be expanded to include optimum intercepts, four-dimensional navigation, and terrain-following-terrain avoidance routines. Optimal evasive maneuvers may then be considered, eventually leading to concepts for automated air combat.

Initially, the trajectory optimization modes will be implemented and used as the basis for evaluating the performance improvements as a result of the HIDEDEC system. A simple example of such an energy management mode is a minimum time flightpath.

An analytical study was conducted to develop a minimum time flightpath for the F-15 aircraft. The Rutowski technique was used. It uses the specific excess power (Ps) of the F-15 superimposed on lines of constant specific energy (Es). The minimum time-path is the locus of points of tangency between the Ps and the Es lines. The Ps contours for the F100 EMD-powered F-15 airplane and the minimum time flightpath are shown in Fig. 12. For this evaluation, the mission was a minimum time climb and acceleration to a high-altitude supersonic flight condition. The path that was followed included a level acceleration at low altitude, a climbing acceleration to a low supersonic Mach number, a constant energy descent followed by a climbing

acceleration, and a constant energy climb to the final altitude. The time required was 2.53 min.

The performance of the F-15 airplane powered by F100 EMD engines with the uptrim was then evaluated. Ps contours were developed and the minimum time flightpath was developed for the uptrimmed case. The flightpath was similar to that shown in Fig. 12. The time required was 2.28 min.

For an evaluation of the performance improvements due to the integrated flightpath management, a pilot's estimate of the minimum time flightpath was also developed. The pilot was given the F-15 flight manual and was allowed to use his experience in the aircraft; he was not given any Ps contours. The time required was 2.96 min. The improvement in time due to the HIDEC optimum flightpath mode was 15 percent, and the combined improvement due to the HIDEC ASM mode and the optimum flightpath mode was 23 percent.

#### HIDEC Program Schedule

The HIDEC program is divided into phases. In the first phase, the DEFCS was installed on the F-15 airplane to verify its proper operation. The HIDEC digital interface and bus controller were also installed and the 1553 bus and the F-15 H009 data bus were connected.

In the second phase, the flightpath control modes will be flown and evaluated. The pilot will manually follow the commands as indicated on the cockpit display. Results will be compared to simulation results and analytical predictions.

In later phases, the DEEC controllers will be integrated into the system and the ASM mode will be implemented and tested. The modified DEEC software may be evaluated in an altitude facility prior to flight.

#### Concluding Remarks

An investigation of the performance improvements due to the integration of propulsion and flight control systems on an F-15 airplane has been conducted. The process for implementing an adaptive engine stall-margin mode has been studied. Uptrim of engine thrust by 10 percent appears to be practical in regions of the flight envelope where inlet distortion is low. Improvements of up to 23 percent in the time required to reach a supersonic flight condition were also found.

#### References

- <sup>1</sup>Digital Electronic Engine Control (DEEC) Flight Evaluation in an F-15 Airplane," NASA CP-2298, 1984.
- <sup>2</sup>Linebrink, K. L., and Vizzini, R. W., "Full Authority Digital Electronic Control (FADEC)-Augmented Fighter Engine Demonstration," SAE Paper 821371, Oct. 1982.
- <sup>3</sup>Burcham, Frank W., Jr., and Batterton, Peter G., "Flight Experience With A Digital Integrated Propulsion Control System on an F-111E Airplane," AIAA Paper 76-653, June, 1976.
- <sup>4</sup>Reukauf, Paul J., and Burcham, Frank W., Jr., "Propulsion System/Flight Control Integration for Supersonic Aircraft," NASA CP-001, 1976.
- <sup>5</sup>Stern, A. D., and Carlin, C. M., "Study of Integrated Airframe/Propulsion System Architectures (IAPSA)," NASA CR-172173, 1983.
- <sup>6</sup>Bangert, L. H., Henke, K. R., Grommes, R. J., and Kerr, W. B., "Study of Integrated Airframe/Propulsion System Architectures," NASA CR-172167, 1983.
- <sup>7</sup>Joshi, Dinesh S., et al, "A Design Approach to Integrated Flight and Propulsion Control," SAE Paper 831482, Oct. 1983.
- <sup>8</sup>Clifton, J. V., Smith, K. L., Lehtomaki, N. A., and Langton, Roy, "Design Methods for Integrated Control Systems," AIAA Paper 83-2562, Oct. 1983.
- <sup>9</sup>Burcham, Frank W., Jr., and Stewart, James F., "The Development Process for Integrated Propulsion Flight Controls," NASA CP-2162, 1980.
- <sup>10</sup>Myers, L. P., and Burcham, F. W., Jr., "Flight Test Results of an F100 EMD Engine in an F-15 Airplane," AIAA Paper 84-1332, June 1984.
- <sup>11</sup>"F100 EMDP Prototype Engine Flight Demonstration Performance Model, User's Manual for Deck CCD 1194.2," Pratt and Whitney Report FR-16212, Mar. 1983.
- <sup>12</sup>"State Variable Dynamic Model of a PW 1128 Engine, Computer Simulation User's Manual for Deck CCD 1227," Pratt and Whitney Report FR-17738, Sept. 1983.

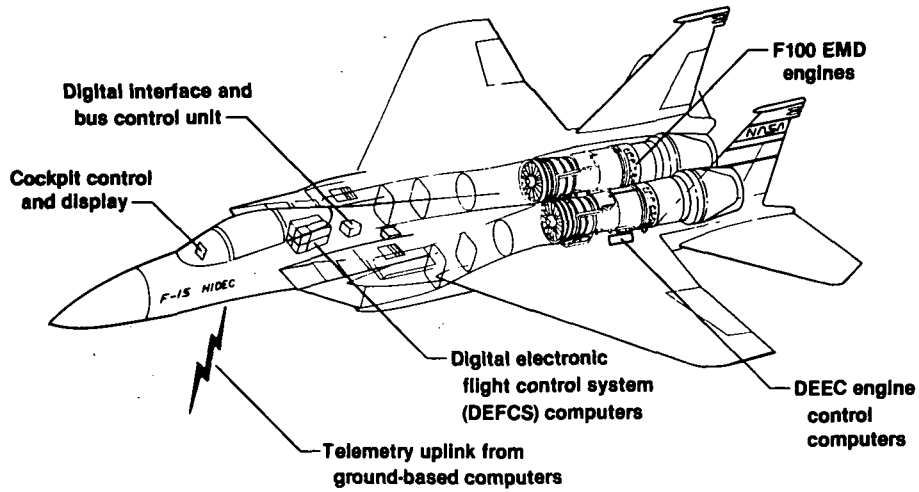

Fig. 1 Features of the F-15 HIDEC research airplane.

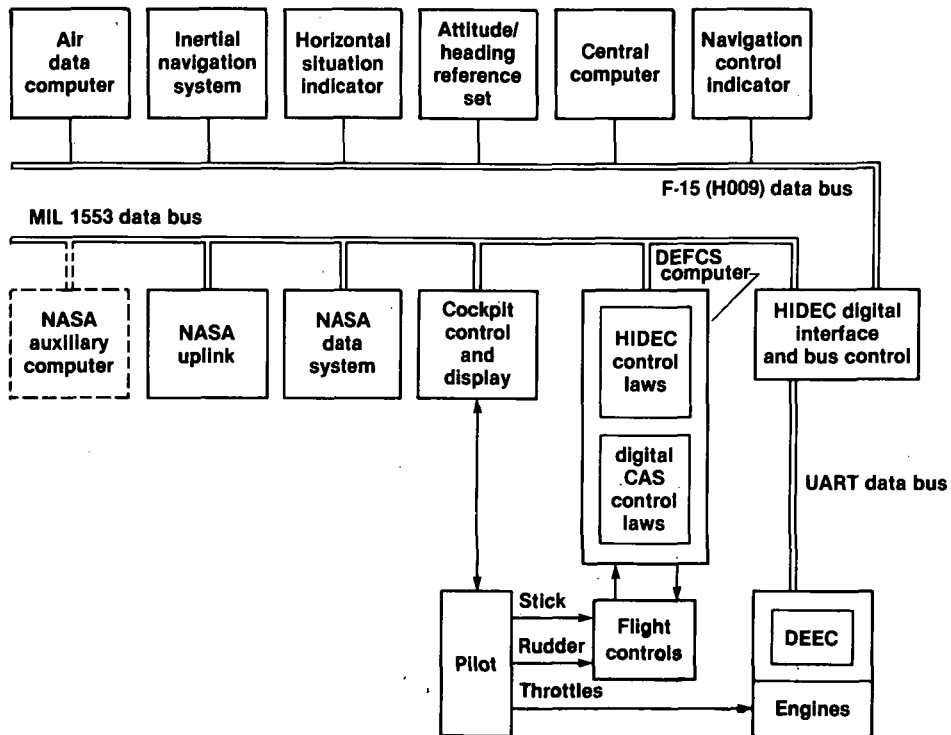

Fig. 2 Block diagram of the HIDEC system.



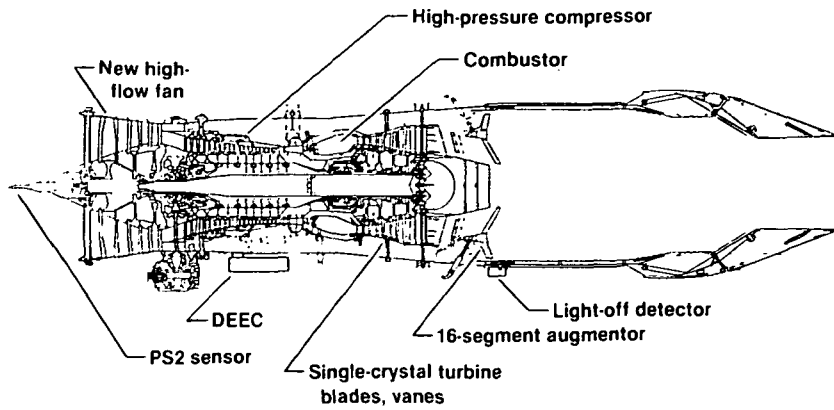

Fig. 3 Features of the F100 EMD engine for the HIDEC program.

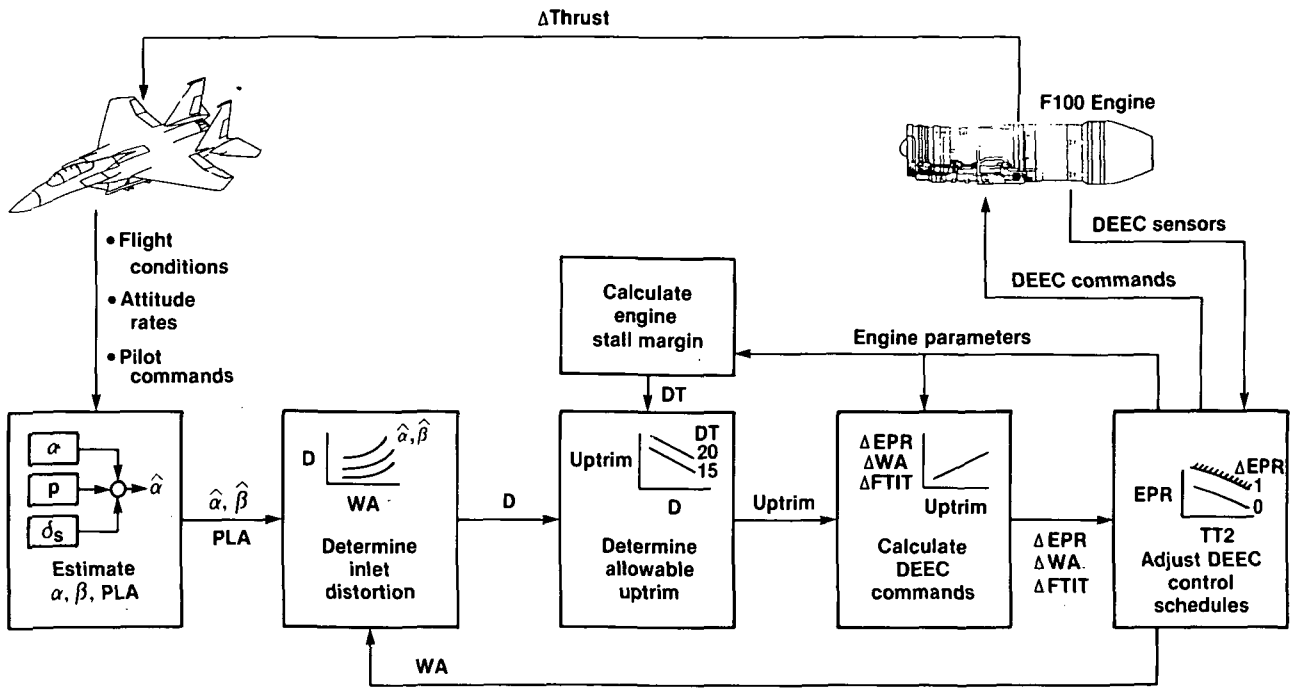

Fig. 4 Block diagram of the HIDEC adaptive stall margin mode.

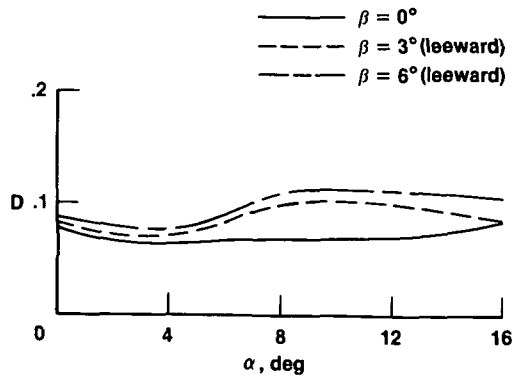

Fig. 5 Effect of  $\alpha$  and  $\beta$  on  $D$  for the F-15;  $M = 1.6$ .

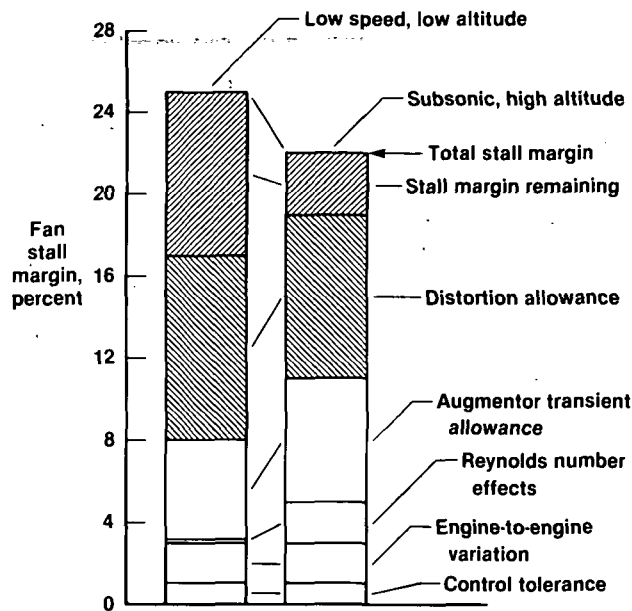

Fig. 6 Typical stability audit for the F100 EMD engine.

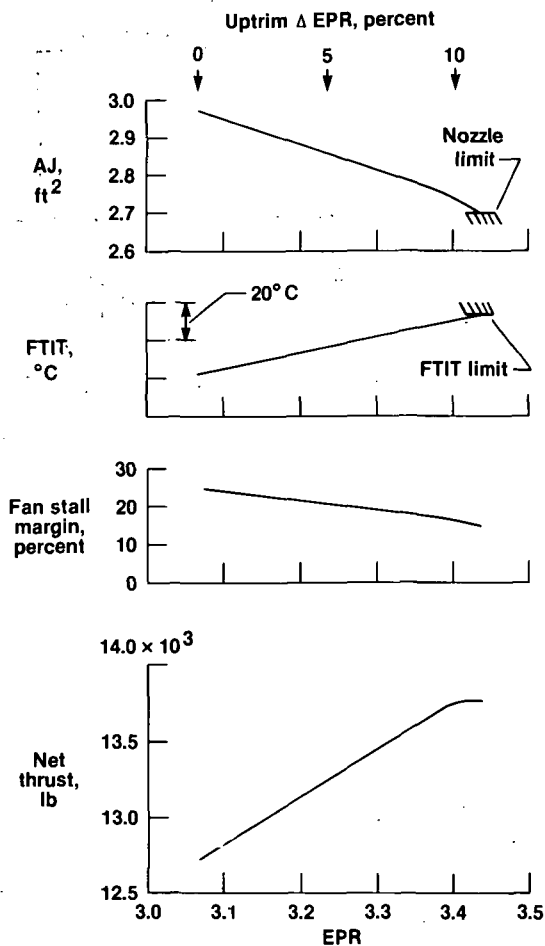

Fig. 7 Evaluation of EPR uptrim using the F100 EMD steady-state simulation at intermediate power, and at low-altitude, low-speed conditions.

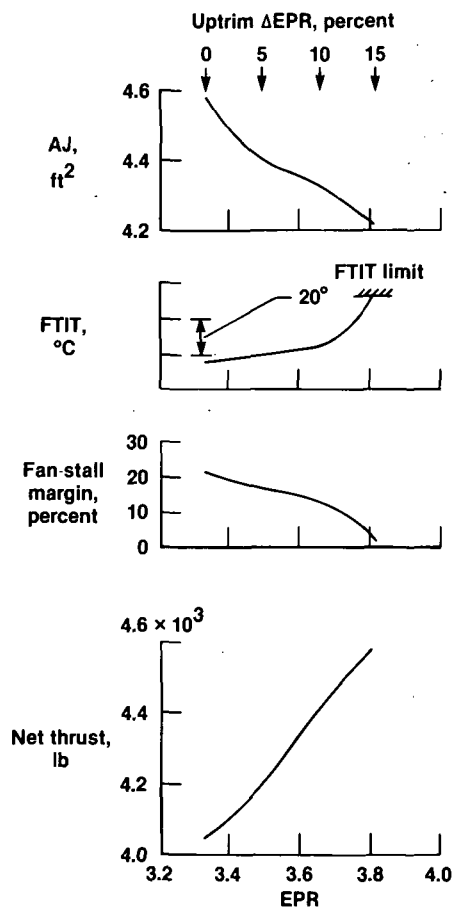

Fig. 8 Evaluation of EPR uptrim using the F100 EMD steady-state simulation at maximum power and at subsonic and high-altitude conditions.

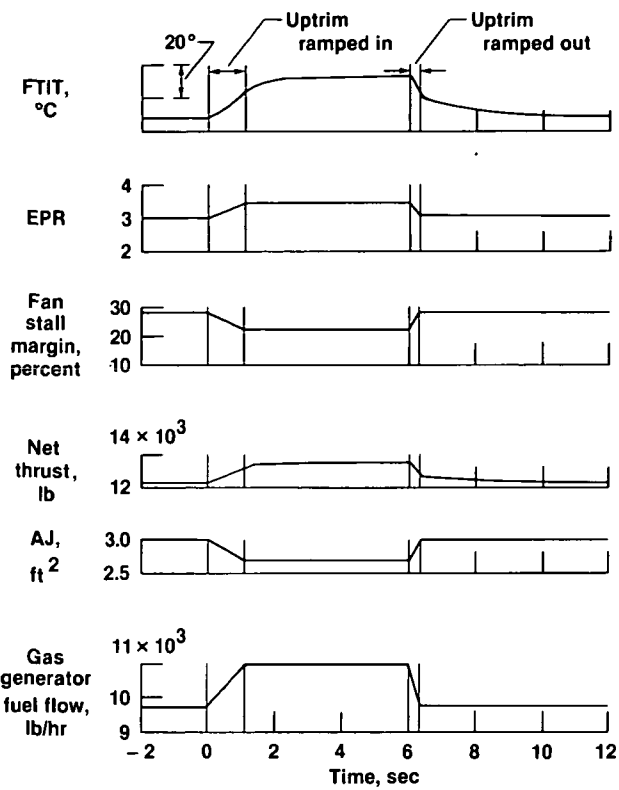

Fig. 9 Evaluation of HIDECA ASM uptrim using the F100 EMD linear state-variable dynamic simulation at intermediate power and at low-altitude, low-speed conditions.

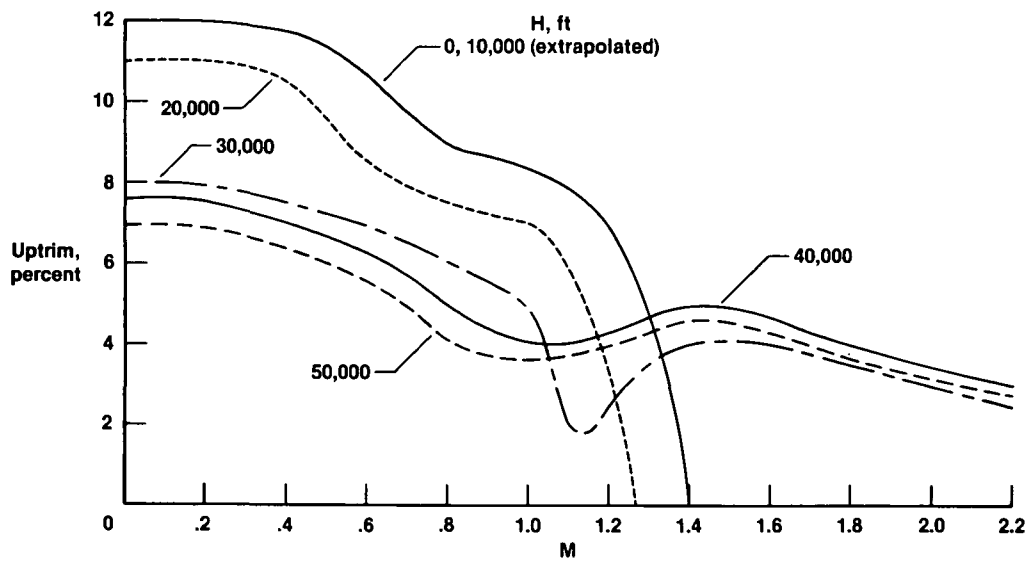

Fig. 10 Uptrim for F100 engine from INTERACT study; maximum power.

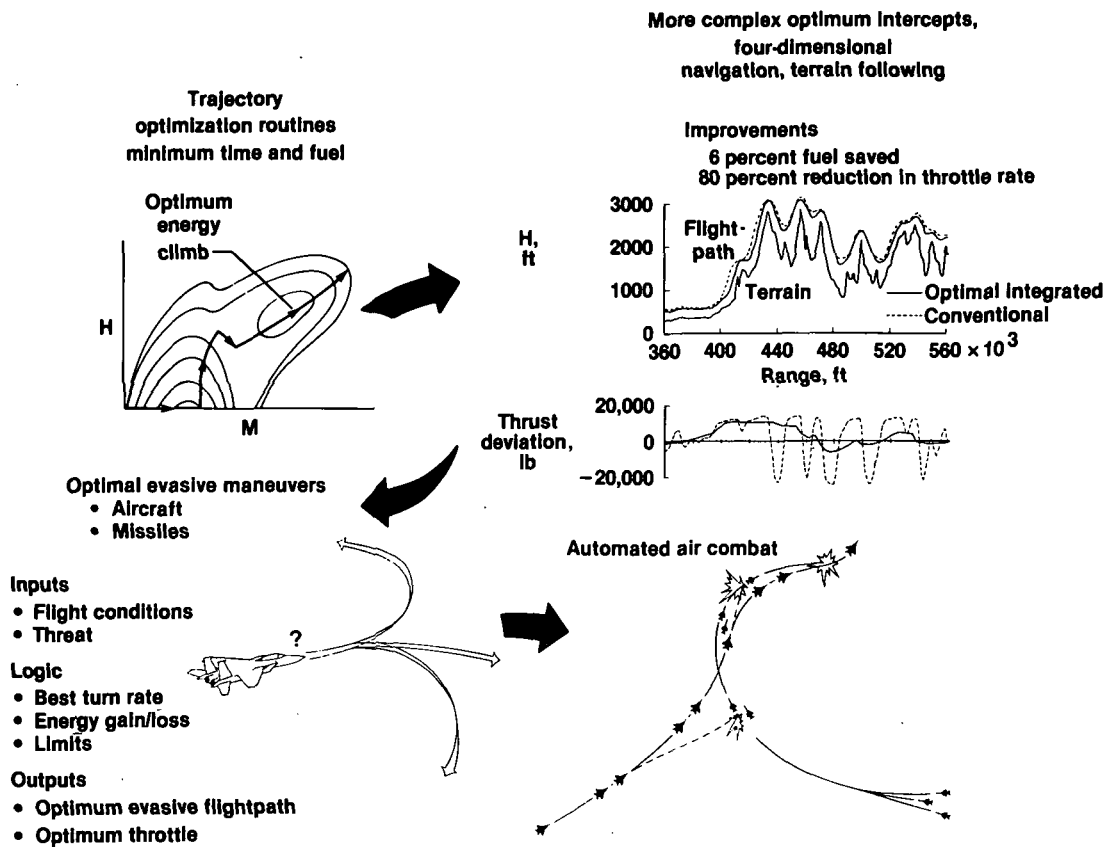

Fig. 11 Integrated flightpath management modes for the HIDEDEC program.

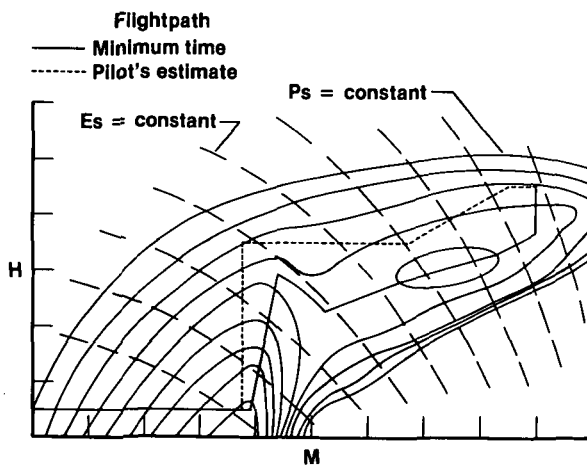

Fig. 12 Es and Ps contours and minimum time flightpaths for the F-15 HIDEDEC at maximum power without uptrim.

1. Report No. NASA TM-86040	2. Government Accession No.	3. Recipient's Catalog No.	
4. Title and Subtitle Highly Integrated Digital Engine Control System in an F-15 Airplane		5. Report Date June 1984	
		6. Performing Organization Code	
7. Author(s) Frank W. Burcham, Jr., and Edward A. Haering, Jr.		8. Performing Organization Report No. H-1240	
		10. Work Unit No.	
9. Performing Organization Name and Address NASA Ames Research Center Dryden Flight Research Facility P.O. Box 273 Edwards, California 93523		11. Contract or Grant No.	
		13. Type of Report and Period Covered Technical Memorandum	
12. Sponsoring Agency Name and Address National Aeronautics and Space Administration Washington, D.C. 20546		14. Sponsoring Agency Code RTOP 533-02-21	
		15. Supplementary Notes This paper was prepared as Paper 84-1259 for the 20th AIAA/ASME/SAE Joint Propulsion Conference, Cincinnati, Ohio, June 11-13, 1984.	
16. Abstract  The highly integrated digital electronic control (HIDEC) program will demonstrate and evaluate the improvements in performance and mission effectiveness that result from integrated engine-airframe control systems. This system is being used on the F-15 airplane at the Dryden Flight Research Facility of NASA Ames Research Center. An integrated flightpath management mode and an integrated adaptive engine stall margin mode are being implemented into the system. The adaptive stall margin mode is a highly integrated mode in which the airplane flight conditions, the resulting inlet distortion, and the engine stall margin are continuously computed; the excess stall margin is used to uptrim the engine for more thrust. The integrated flight-path management mode optimizes the flightpath and throttle setting to reach a desired flight condition. The increase in thrust and the improvement in airplane performance is discussed in this paper.			
17. Key Words (Suggested by Author(s)) Integrated control Digital control Engine control F-15 aircraft Flightpath optimization		18. Distribution Statement Unclassified-Unlimited  STAR category 07	
19. Security Classif. (of this report) Unclassified	20. Security Classif. (of this page) Unclassified	21. No. of Pages 10	22. Price* A02

\*For sale by the National Technical Information Service, Springfield, Virginia 22161.