

NASA Technical Memorandum 84360

Airborne Astronomy Program
Medium Altitude Missions Branch
Preprint Series 011

Neutral Carbon in the Egg Nebula (AFGL 2688)

C.A. Beichman, Jocelyn Keene,
T.G. Phillips, P.J. Huggins,
H.A. Wooten, C. Masson
and M.A. Frerking

April 1983

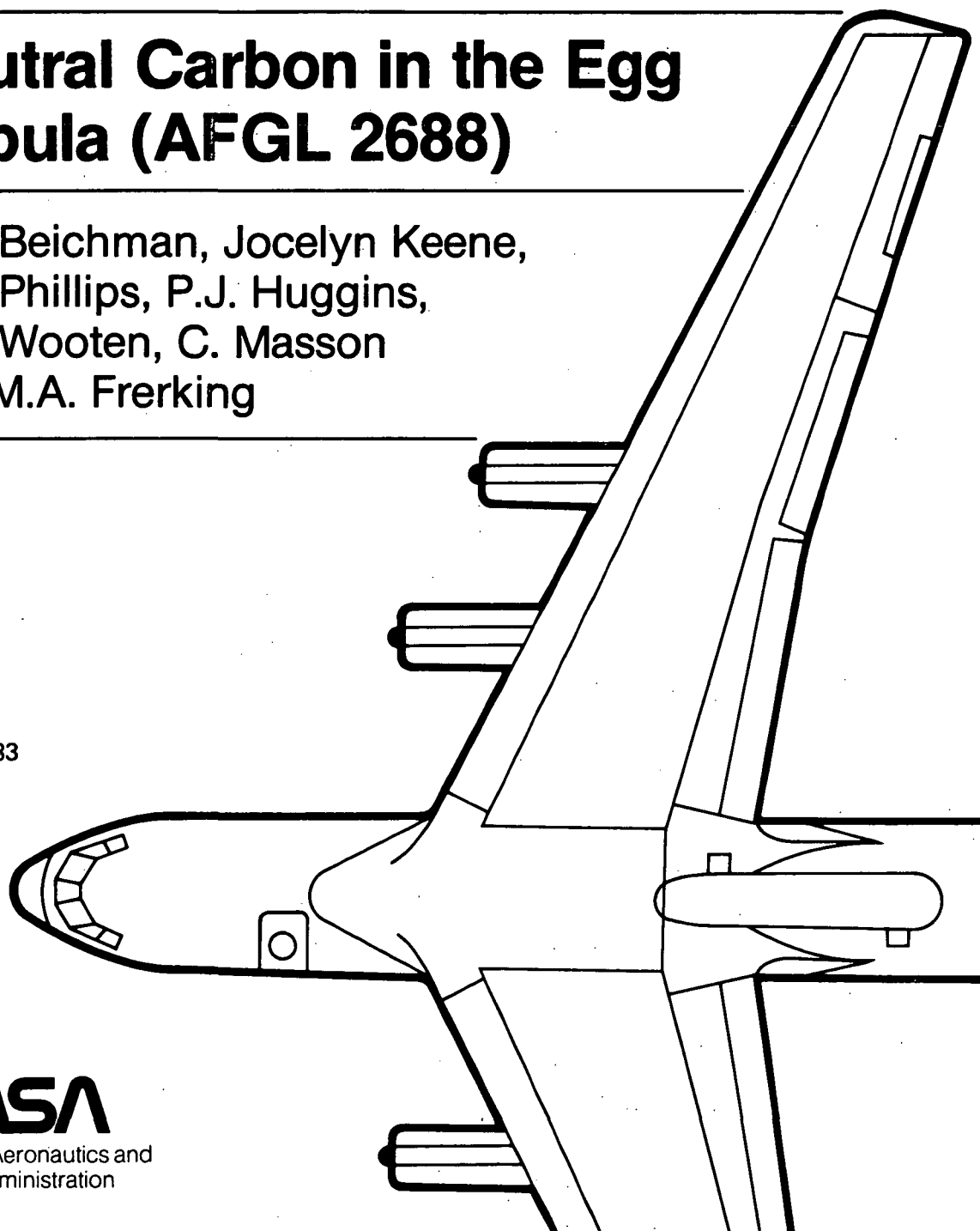

NASA
National Aeronautics and
Space Administration

Neutral Carbon in the Egg Nebula (AFGL 2688)

C. A. Beichman, Jet Propulsion Laboratory, California Institute of Technology, Pasadena, California

Jocelyn Keene

T. G. Phillips, California Institute of Technology, Pasadena, California

P. J. Huggins, New York University, New York, New York

H. A. Wooten

C. Masson, California Institute of Technology, Pasadena, California

M. A. Frerking, Jet Propulsion Laboratory, California Institute of Technology, Pasadena, California



National Aeronautics and
Space Administration

Ames Research Center
Moffett Field, California 94035

Neutral Carbon in the Egg Nebula (AFGL 2688)

by

C.A. Beichman^{1,2,3}, Jocelyn Keene^{2,3}, T.G. Phillips^{2,3},

P.J. Huggins⁴, H. A. Wootten^{2,3,5}, C. Masson³ and M. A. Frerking¹

1. Jet Propulsion Laboratory, California Institute of Technology.
2. Visting Astronomer at the Infrared Telescope Facility which is operated by the University of Hawaii under contract to the National Aeronautics and Space Administration.
3. Division of Physics, Mathematics and Astronomy, California Institute of Technology.
4. Dept. of Physics, New York University.
5. Dept. of Physics, Rensselaer Polytechnic Institute.

Accepted for publication in the Astrophysical Journal

ABSTRACT

Observations have been made in the 492 GHz line of atomic carbon (C I) toward eight evolved stars with circumstellar envelopes. The observations of one star, AFGL 2688, also known as the Egg Nebula, yielded the detection of a line ($T_A^* \sim 0.9$ K) with a central velocity and width that are the same, within the uncertainties, as those measured in CO. The large CI/CO abundance ratio implied by the data for AFGL 2688 suggests that $[C]/[O] > 4$ in this object. Upper limits to the CI/CO ratio are reported for seven other stars, including IRC+10216 and NGC 7027.

I. INTRODUCTION

The detection toward molecular clouds of submillimeter line emission from the $3P_1-3P_0$ transition of atomic carbon (Phillips et al., 1980; Phillips and Huggins 1981) provides a new probe of the chemistry of the interstellar medium. As millimeter wavelength radiation from interstellar molecules has been found to originate in the envelopes of evolved stars undergoing mass loss as well as in molecular clouds (see, for example, the review by Zuckerman 1980), it is natural to ask whether atomic carbon emission can be observed toward such stars also. The material shed by a red giant star has been processed by nuclear burning during the star's evolution with the result that the atomic abundances of the ejecta can be very different from canonical interstellar abundances. The chemistry and dynamics of circumstellar shells are important to our understanding of the later stages of stellar evolution and of the enrichment of the interstellar medium with nuclear-processed material.

We have searched for CI emission toward seven stars known from CO observations to have extensive shells and toward R Cor Bor, an unobscured, hydrogen-deficient, carbon star. In the case of AFGL 2688, an object thought to be a carbon star on its way to becoming a planetary nebula, (Ney et al., 1975; Zuckerman et al., 1976) we find evidence for weak CI emission. Toward the other seven stars no CI emission was found. The upper limits place significant constraints on the CI/CO ratio for IRC+10216 and NGC 7027.

II. OBSERVATIONS

Observations of the CI line at 492162.3 MHz (the laboratory frequency measured by Saykally and Evenson 1980) were made using an InSb hot electron bolometer receiver similar to that described in detail by Phillips and Jefferts (1973). The system noise temperature varied between 350 and 600 K for the various sets of observations. A single 0.6 km s^{-1} wide channel was swept in 1-2.5 km s^{-1} steps across the spectral range of interest by stepping the klystron local oscillator under computer control.

The CI line falls in the submillimeter band of the electromagnetic spectrum where atmospheric water vapor causes considerable absorption. Observations from either an airborne observatory or from a high, dry ground-based site are essential. The observations reported here were obtained with the 1 m telescope aboard the Kuiper Airborne Observatory (KAO) and with the NASA 3 m Infrared Telescope Facility (IRTF) on top of Mauna Kea, Hawaii. In the case of exceptionally good weather, and for the study of small objects the larger aperture of the IRTF can offset the extra atmospheric attenuation from the mountain top. Some objects were observed with both telescopes, but others with only one.

At the KAO the receiver was located at the bent Cassegrain focus. The diffraction-limited beam size is 2.5 arcmin and the beam efficiency approximately 35 percent as deduced from observations of the moon and hot and cold loads. The atmospheric

attenuation at the typical observing altitude of 13 km is negligible.

At Mauna Kea the receiver was mounted at the Cassegrain focus of the IRTF. Scans across Jupiter showed the beam to be 45''(FWHM) in size with an efficiency of 30 percent. During the course of a 5 day observing run in January/February 1981, usable data were obtained with zenith optical depths as low as 1.0-1.5 as deduced from plots of sky emission as a function of zenith angle. During the daytime it was possible to measure the amount of water vapor in the line of sight to the sun using a near-infrared absorption technique (Westphal 1974). On three days, values between 0.6-1.0mm H₂O to the zenith were measured.

III. RESULTS

The CI line was detected in AFGL 2688 and upper limits were obtained for the remaining seven stars. All of the results are presented in Table I which gives the date of the observation, the central velocity of the spectrum (based on CO observations), the telescope beamwidth (FWHM in arcmin) and the CI antenna temperature corrected for antenna losses and atmospheric attenuation (T_A^*). Upper limits are 3σ and were obtained by integrating the CI spectrum over the line width expected on the basis of the CO line. For R Cor Bor no CO data are available and the upper limit is that in a single frequency channel. The calibration is such that T_A^* for the Orion Molecular Cloud (OMC-1) is 11 K (Phillips and Huggins 1981). The table also lists

observations of $^{12}\text{CO}(J=1-0)$ and $^{13}\text{CO}(J=1-0)$. $^{12}\text{CO}(J=2-1)$ observations for all these stars are given by Knapp et al. (1982).

Figure 1 (upper) shows the CI spectrum of AFGL 2688 with 2.44 km s^{-1} resolution. Data from two separate KAO flights were co-added, a linear baseline removed and the resultant spectrum Hanning smoothed. If random noise dominated the CI spectrum of AFGL 2688, then the formal significance of the result would be 6σ . Since systematic uncertainties such as imperfect baseline subtraction are probably greater than the gaussian noise component, the fact that the central velocity and width of the CI line match those observed in CO provides strong evidence that the feature in the spectrum is a real line and not an instrumental artifact.

The best fit line parameters for a flat-topped line profile are $T_{\text{A}}^* = 0.9 \pm 0.3 \text{ K}$ and a full width of $41 \pm 5 \text{ km s}^{-1}$, where the uncertainty in T_{A}^* includes a 30 percent calibration uncertainty. A detailed examination of the radiative transfer through circumstellar material (e.g. Morris 1975) shows that emission from a spatially unresolved shell results in a parabolic line shape for optically thick material and in a rectangular line profile for optically thin gas. With the present data it is not possible to determine whether the CI line is flat-topped or parabolic.

A new ^{13}CO observation was made of AFGL 2688 with a 10 m telescope at the Owens Valley Radio Observatory (OVRO). The lower

portion of figure 1 shows the ^{13}CO spectrum smoothed to the resolution comparable to that of the CI spectrum. The ^{13}CO line is flat-topped, implying optically thin emission from an unresolved shell. The observed antenna temperature of 0.30 ± 0.05 K is twice the 0.15 ± 0.05 K reported by Lo and Bechis (1976). The discrepancy is probably due to an overestimate of the beam efficiency (Ulich and Haas 1976) of the National Radio Astronomy Observatory (NRAO) 11m telescope. The ^{12}CO value given in Table 1 has been increased by a factor of 1.5 to account partially for this effect. It should be pointed out that the ^{13}CO observation of AFGL 2688 reported by Thronson and Mozurkewich (1983) is a factor of four lower than the Lo and Bechis value and a factor of eight lower than the value reported here. The reason for the discrepancy is not clear.

IV. DISCUSSION

CI/CO Ratio in Circumstellar Shells

To understand the implications of the CI results, we use some simple models to estimate or set limits to the CI/CO abundance ratio. The particular case of AFGL 2688 is discussed further in the next section. We consider first a picture wherein a mixture of CO and CI at a single temperature surrounds each star. Using LTE relationships given in Phillips and Huggins (1981) and in Knapp *et al.* (1982) it is straightforward to show that the column densities of CI atoms and CO molecules in an unresolved, optically thin shell are given by

$$(1) N_{\text{CI}} = 1.99 \times 10^{15} (3 + e^{23.6/T_{\text{CI}}} + 5e^{-38.8/T_{\text{CI}}}) (\theta_{\text{B}}/\theta_{\text{e}})^2 / T_{\text{A}}^* dV \text{ (cm}^{-2}\text{)}$$

and

$$(2) N_{\text{CO}} = 4.2 \times 10^{13} T_{\text{CO}} (\theta_{\text{B}}/\theta_{\text{e}})^2 / T_{\text{A}}^* dV \text{ (cm}^{-2}\text{)}$$

for the CO(J=1-0) transition. The ratio of the number of CI atoms to the number of CO molecules is given by

$$(3) N_{\text{CI}}/N_{\text{CO}} = 47.4 f(T_{\text{CO}}, T_{\text{CI}}) (T_{\text{A}}^* \theta_{\text{B}}^2)_{\text{CI}} / (T_{\text{A}}^* \theta_{\text{B}}^2)_{\text{CO}}$$

θ_{B} is the telescope beamsize, θ_{e} the size of the emitting region and the intensity integral has units of K km s^{-1} . In eqn. (3) equal line profiles are assumed for each species. The function $f(T_{\text{CO}}, T_{\text{CI}})$ corrects for the excitation temperature dependent populations in the emitting states of CI and CO:

$$(4) f(T_{\text{CO}}, T_{\text{CI}}) = (3 + e^{23.6/T_{\text{CI}}} + 5e^{-38.8/T_{\text{CI}}}) / T_{\text{CO}}$$

where T_{CI} and T_{CO} are the excitation temperatures for CI and CO.

The applicability of eqn. (3) depends on the apparent size of the emitting region being small with respect to the telescope beamwidth. Scans made across all of these stars, in either CO J=1-0 or J=2-1, show that the bulk of the emission arises from regions smaller than 0.5-1 arcminute (Kwan and Linke 1982; Knapp

et al. 1982). Thus, resolution effects are negligible for the CI observations obtained with a 215 beam and unimportant for the data obtained with 0.75-1' beams in light of the other uncertainties.

Applying eqn. (3) requires the choice of an excitation temperature. A value of 50 K is used for both T_{CO} and T_{CI} based on the discussion of Knapp, Phillips and Huggins (1980) and Kwan and Linke (1982). The latter authors found that for IRC+10216 the shell temperature varied from 200 K to 15K across the central 60" of the shell. For $T_{CI} > 15K$ eqn. (4) is insensitive to the exact value of T_{CI} . Estimates of CI/CO should not be in error by more than a factor of two due to the adoption of 50 K.

Eqn. (3) gives a realistic estimate of the CI/CO ratio if both lines are optically thin. Because examination of the line profiles shows that ^{12}CO is optically thick in these stars, the ratio given by eqn. (3) must be divided by an estimate of the average opacity in ^{12}CO . The upper limits obtained from ^{12}CO measurements have been divided by an estimate of the average line optical depth ~ 4 . Such optical depths are deduced from a comparison of observed line profiles with theoretical models, c.f. the discussion in Knapp, Kuiper and Zuckerman (1979). Table 2 gives $N(CI)/N(CO)$ derived from eqn. (3) using the data presented in Table 1.

An alternative method for determining $N(CI)/N(CO)$ is to use eqn. (3) for the ^{13}CO line which, from its flat-topped profile is

known to be optically thin in most circumstellar shells. The derived $\text{CI}/^{13}\text{CO}$ ratio is converted to a CI/CO ratio (given in Table 2) using an estimate of the $^{12}\text{C}/^{13}\text{C}$ abundance ratio. For AFGL 2688, Morris (1980) found $^{12}\text{CO}/^{13}\text{CO} \sim 8$, depending only on the ^{12}CO line profile and the ratio of the ^{12}CO and ^{13}CO intensities observed by Lo and Bechis (1976)—quantities independent of the absolute calibration of the NRAO telescope. Upper limits for the other stars where ^{13}CO data are available, use $^{12}\text{C}/^{13}\text{C} \sim 30$ as deduced from IR and millimeter results (Wannier and Linke 1978; Rank *et al.* 1974). .cp 5

Upper limits are set for IRC+10216 and NGC 7027 of $\text{CI}/\text{CO} < 1$. For AFGL 2688 the estimates of CI/CO are 5 and 15 with the larger value coming from using the ^{13}CO observation. If $^{12}\text{C}/^{13}\text{C}$ were larger than 8, then the two estimates would be in closer accord. In the discussion below we use the more conservative estimate for CI/CO of 5. It is hard to attach an uncertainty to the CI/CO ratio. If the simple model of a mixture of species at a single temperature applies and if the CI is optically thin, then the estimates given in Table 2 are probably valid within a factor of 2. In the case of the Egg Nebula this means that CI/CO must at least exceed ~ 2 . The idea of a single value of CI/CO may be unrealistic due to the strong radial gradients of both temperature and UV flux that exist in the material surrounding AFGL 2688. However, the quality of the present data do not warrant the detailed radiative transfer analysis needed to treat this question rigorously.

A Specific Model for CI Emission from AFGL 2688

AFGL 2688 is a very carbon-rich star (Zuckerman et al. 1976), as indicated by the presence of C₂ Swan bands, C₃ absorption (Crampton, Cowley and Humphreys 1975) and SiC₂ bands (Cohen and Kuhl 1977). The detection of CI toward AFGL 2688 and the failure to detect the line toward other stars ought to be understood in terms of the elemental abundances, the shell chemistry and the excitation conditions within the circumstellar shells.

The amount of CI present in a circumstellar shell depends on both the intrinsic atomic abundances and the physical conditions which determine the ionization and molecular association of the gas phase atoms and their depletion onto grains. Tentative ideas on the relevant chemistry have been discussed in the literature (Huggins and Glassgold 1982; and McCabe et al. 1979). The general picture is one in which molecules and dust grains are formed in the inner wind flow, but are eventually dissociated again into their constituent atoms and ions in the outer reaches of the shell by the ambient galactic UV radiation field.

Huggins and Glassgold (1982) investigated the photochemistry in the outer shell of IRC+10216 and found that CO can be dissociated into CI by the galactic UV field at the surface of the shell. Such behavior is seen toward molecular clouds where UV from HII regions breaks up CO to manufacture copious amounts of CI (Wootten et al. 1982). The conversion of CO itself into CI is,

however, a rather inefficient process due to the slow photo-destruction rate of CO and the faster conversion of CI to CII. In the case of IRC+10216 Huggins and Glassgold found that the CI/CO ratio reached a maximum value of 0.2 at a radius of 10^{17} cm; if CO line self-shielding is important this ratio will be much lower (Morris and Jura 1983). These results are consistent with the upper limit reported here. It seems unlikely, therefore, that our detection of CI in AFGL 2688, implying $CI/CO > 1$, is a result of CI production from CO. However, as Huggins and Glassgold point out, CI can also be photo-produced in significant amounts from other abundant carbon-bearing species, such as C_2H_2 , which are more readily converted into CI. If these species are sufficiently abundant (as might occur, for example, if oxygen were severely depleted relative to carbon, resulting in the formation of large amounts of carbon bearing polyatomic molecules), there will be regions in the envelope where CI is more abundant than CO.

An alternative possibility which might be considered is that the CI is produced in a small volume around the star where the gas is shock ionized. The observation of strong H_2 emission from AFGL 2688 (Thronson 1982) suggests the existence of such material. However, the number of atoms required to explain the observed CI emission would be too great to be contained in such a small volume.

A property of models invoking the photo-production of CI is that the CI will originate from a fairly extended shell. The ratio of CI to CO antenna temperatures is consistent with this

requirement. The CO emission from AFGL 2688 appears to be optically thick, based upon the observed ratios of the J=2-1 and J=1-0 lines (Knapp *et al.*, 1982) and the strength of the ^{13}CO line. If the CI line arises in the same region as the CO line, is optically thick, and is also thermalized, the ratio of antenna temperatures in the lines should be approximately equal to the inverse ratio of the beam areas used for the observations. For excitation temperatures greater than 25 K the ratio of CI to CO antenna temperatures should be between 0.13 and 0.19 (the range is due to the breakdown in the Rayleigh-Jeans approximation at low temperatures), which is less than the observed temperature ratio of 0.6 ± 0.2 . If the CI emission is optically thin, the anticipated ratio is even lower.

The ratio of antenna temperatures can be used to estimate the sizes of the emitting regions if an assumption is made about the shell temperatures. Lacking a detailed model for the structure of the outer envelope of the circumstellar shell, we assume that the shell of AFGL 2688 is similar to that of IRC+10216 for which models have been published. In the Kwan and Linke (1982) model the shell temperature varies with radius as $T_r^{-.6}$. It is possible to relate the sizes of the emitting regions to the observed antenna temperatures using the above temperature-radius relation and a relation between antenna temperature, excitation temperature and beam size in the optically thick limit (and ignoring the 3K background radiation) :

$$(5) T_A^* = (hc/\lambda k)(\theta_* / \theta_B)^2 / (e^{hc/\lambda k T} - 1).$$

The equation that must be solved is, then,

$$(6) [\lambda \theta_*^{-0.6} \ln(1 + (hc/\lambda k T_A^*)(\theta_* / \theta_B)^2)]_{CI} =$$

$$[\lambda \theta_*^{-0.6} \ln(1 + (hc/\lambda k T_A^*)(\theta_* / \theta_B)^2)]_{CO}$$

where θ_* is the size of the emitting region, λ the wavelength of the transition and θ_B is the telescope beam size. The size of the optically thick CO region is approximately 10-15" (Knapp *et al.* 1982; Wannier, private communication 1982). Solving eqn. (6) yields 30-80" for the size of the CI region, much smaller than the 2.5 beam of the KAO but perhaps similar to the 50" beam of the IRTF. The excitation temperatures corresponding to these sizes are 45 K for CO and 25 K for CI.

In this model a cool cloud of CI, created from the dissociation of more stable molecular species such as CO and C₂H₂ by galactic UV, surrounds a smaller, somewhat warmer, cloud of CO. As mentioned above the shell material must be oxygen deficient lest most of the carbon be in the form of CO and CII. The dredging-up of material with [C]/[O] > 1 from deep within a star is anticipated on theoretical grounds (Iben 1981; Becker and Iben 1980). The amount of carbon enhancement depends on the initial mass of the star with more luminous stars having larger [C]/[O] ratios. Iben (1981) has modelled the [C]/[O] ratio as a

function of stellar type and age. To apply these models requires knowledge of the luminosity and hence of the distance of AFGL 2688 from the earth. This is quite uncertain. A value of 1.5 kpc is consistent with the inferred interstellar absorption to the star (Cohen and Kuhi 1977), with the star's classification as a F5Ia supergiant (Crampton, Cowley and Humphreys 1975) and with the radial velocity of the object (Humphreys 1976). At this distance the luminosity of the object, based on far-infrared observations, is $\sim 5 \times 10^4 L_0$ (Kleinmann et al. 1978). Such a star can have $S>[C]/[O]>4$ (Iben 1981).

Whether or not the chemistry of a shell with $[C]/[O] \sim 4-8$ can produce a CI line of the observed strength is unknown, because the details of the chemistry are quite complicated. Before appealing to extreme elemental abundances or peculiar chemical processing it should be noted that the line ratios in other species observed toward AFGL 2688 such as HCN, CS and HC_3N are quite similar to those seen toward IRC+10216 (Zuckerman et al. 1976). If the lines are optically thin, then these species show little evidence for departures from normal abundances and the line ratios place constraints on the variation of conditions in AFGL 2688, toward which CI is observed and IRC+10216, toward which it is not. If these other lines are optically thick, however, then the line ratios are insensitive to abundance variations.

The total shell mass and the mass loss rate deduced from the CI data provide a check on this model. If the CI emission is

optically thin and comes from a volume smaller than the 2.5' beam, the number of CI atoms is given by

$$(7) N_{\text{CI}} = 1.27 \times 10^{51} (3 + e^{23.6/T} + 5e^{-38.8/T}) (d\theta_{\text{B}})^2 / T_{\text{A}}^{\circ} dV,$$

where d is the distance in kpc and θ_{B} is in arcminute. For $T=50$ K and $d=1.5$ kpc, $N_{\text{CI}}=4.9 \times 10^{54}$ and the total mass of the shell material, assuming $[\text{H}]/[\text{C}]=500$ (Becker and Iben 1979), is $2.0 M_{\odot}$. If the CI emission is optically thick, the derived mass is even higher. From the outflow velocity of 20 km s^{-1} and a radius of $30''$ (7×10^{17} cm at a distance of 1.5 kpc) the resulting mass loss rate is about $2 \times 10^{-4} M_{\odot} \text{ yr}^{-1}$ which is at the high end, but still consistent with, the values deduced for other evolved stars (Knapp *et al.* 1982).

V. CONCLUSIONS

We have searched for submillimeter CI emission from seven stars surrounded by dense shells of molecular gas. In one case, AFGL 2688, we have detected a 0.9 K line, implying $\text{CI}/\text{CO} > 5$. The material surrounding this star must be extremely carbon-rich. The fact that the CI emitting region appears to be larger than the CO emitting region may be the result of the effects of the galactic UV field on the shell chemistry as suggested by Huggins and Glassgold (1982).

The failure to find CI toward IRC+10216 is puzzling, but may

mean that [C]/[O] is not as great in this star as in AFGL 2688. These observations probably represent the best that can be accomplished with current receivers and telescopes, but could be improved considerably when large submillimeter telescopes at dry sites become available. Systematic observations of CI emission from stars can provide an important probe of the [C]/[O] ratio in evolved stars. The variation of [C]/[O] with stellar luminosity and other observables will provide important tests for theoretical models of the evolution of carbon stars.

VI. ACKNOWLEDGEMENTS

We thank G .R. Knapp for making ^{13}CO observations of a number of stars and Nick Scoville for valuable discussions. The crews of the IRTF and KAO were, as usual, unstinting with their enthusiasm and assistance. Airborne submillimeter line astronomy at Caltech is supported by NASA grant NAG 2-1. Ground based observations are supported by NSF grant AST 8007645.

Table 1. Observational Results

Star	Date	V_{LSR} (km s ⁻¹)	θ ($''$)	$T_{\text{A}}^*(\text{CI})$ (K)	$T_{\text{A}}^*(^{12}\text{CO})$ (K)	$\Delta V(\text{FWZI})$ (km s ⁻¹)	$T_{\text{A}}^*(^{13}\text{CO})$ (K)	refs.
o Ceti	11/81	47	2.5	<1.3	0.5	9	0.055±0.002	1,3
AFGL 618	11/81	-25	2.5	<0.6	0.6	36	0.030±0.005	2,3
IRC+10216	1/80 1/81	-26	2.5 0.75	<0.7 <1.6	9.0	34	0.24	3,4
CIT 6	2/81	-2	0.75	<2.0	0.6	34	0.027±0.004	3,5
R CrB	8/81	45	2.5	<1.4 ¹	<0.2	-		6
IRC+20326	1/81	-4	0.75	<5.4	0.4	38		1
AFGL 2688	8/81 11/81	-35	2.5	0.9±0.3	1.5 ²	40	0.3±0.05	2
NGC7027	11/81 1/81	24	2.5 0.75	<0.6 <3.1	2.0	44	0.020±0.008	3,7

1) The limit represents the value in a single channel since no line width is available from CO data.

2) Value increased by a factor of 1.5 as discussed in text.

References: 1) Lo and Bechis 1977; 2) Lo and Bechis 1976; 3) G. R. Knapp 1981, private communication; 4) Kwan and Linke 1982; 5) Knapp, Kuiper and Zuckerman, 1979; 6) Knapp *et al.*, 1981; 7) Mufson *et al.*, 1975.

Table 2. CI/CO Ratio in Stars

Star o Ceti	θ (')	CI/CO from ^{12}CO <23	CI/CO from ^{13}CO <12
AFGL 618	2.5	<8.9	<10
IRC+10216	2.5 0.75	<1.2 <0.2	<2.1 <0.4
CIT 6	2.5	<1.2	<2.1
IRC+20326	0.75	<10.7	-
AFGL 2688	2.5	5.4	16
NGC 7027	0.75 2.5	<1.3 <2.7	<7.2 <16

REFERENCES

- Becker, S.A. and Iben, I. 1979, Ap. J., 232, 831.
- Becker, S.A. and Iben, I. 1980, Ap. J., 237, 111.
- Cohen, M. and Kubi, L.V. 1977, Ap. J., 213, 79.
- Crampton, D., Cowley, A.P. and
Humphreys, R. M. 1975, Ap. J.(L), 198, L135.
- Huggins, P.J. and Glassgold, A. E. 1982, Ap. J., 252, 201.
- Humphreys, R. M. 1976, Ap. J. 206, 114.
- Iben, I. 1981, Ap. J., 246, 278.
- Kaler, J. B. 1981, Ap. J., 249, 201.
- Kleinmann, S. G., Sargent, D. G., Moseley, H., Harper, D. A.,
Lowenstein, R. F., Telesco, C. M., Thronson, H. A., Jr. 1978,
Astron. and Astrop., 65, 139.
- Knapp, G. R., Kuiper, T. B. H., Zuckerman, B. 1979,
Ap. J., 233, 140.
- Knapp, G. R., Phillips, T. G., Leighton, R. B., Lo, K.Y.,
Wannier, P. G., Wootten, H. A. 1982, Ap. J., 252, 616.
- Knapp, G. R., Phillips, T. G., Huggins, P.J. 1980, Ap. J.(L), 242, L25.
- Kwan, J. and Linke, R. A. 1982, Ap. J., 254, 587.
- Lambert, D. L. 1976, Ap. J., 200, 675.
- Lo, K. Y. and Bechis, K. 1976, Ap. J.(L), 205, L21.
- Lo, K. Y. and Bechis, K. 1977, Ap. J.(L), 218, L27.
- McCabe, E. M., Smith, R. C., Clegg, R.E.S., 1979, Nature, 281, 263.
- McCarthy, W. J., Forrest, J. F. and Houck, J., 1978, Ap. J.,
224, 109.

- Morris, M. 1975, Ap. J., 197, 603.
- Morris, M. 1980, Ap. J., 236, 823.
- Morris, M. and Jura, M. 1983, preprint.
- Moseley, H. 1980, Ap. J., 238, 892.
- Nussbaumer, H. 1971, Ap. J., 166, 411.
- Ney, E. P., Merrill, K.M., Becklin, E.E., Neugebauer, G.,
Wynn-Williams, C. G. 1975, Ap. J.(L), 198, L129.
- Phillips, T. G., Huggins, P.J., Kuiper, T.B. H.,
Miller, R. E. 1980, Ap. J.(L), 238, L103.
- Phillips, T.G. and Huggins, P.J. 1981, Ap. J., 251, 533.
- Phillips, T. G. and Jefferts, K. B. 1973; Rev. Sci. Instr., 44, 1009.
- Rank, D. M., Geballe, T. R., Wollman, E. R., 1974,
Ap. J. (L), 187, L111.
- Saykallay, R. J. and Evanson, K. 1980, Ap. J.(L), 238, L107.
- Scalo, J. M. and Ulrich, R. K. 1973, Ap. J., 183, 151.
- Thronson, H. A. 1982, preprint.
- Thronson, H.A. and Mozurkewich, D. 1983, Ap. J., 271, in press.
- Ulich, B. L. and Haas, R. W. 1976, Ap. J. (Suppl), 30, 247.
- Wannier, P. G. and Linke, R. A. 1978, Ap. J., 225, 130.
- Westphal, J.A. 1974 Final Report for NASA grant 05-002-185;
NASA CR 139693 N74-32782.
- Wootten, H. A., Phillips, T. G., Beichman, C. A., Frerking, M. A.
1982, Ap. J. (L), 256, L5.
- Zuckerman, B. 1980, Ann. Rev. Astr. and Astrop., 18, 263.
- Zuckerman, B., Gilra, D. P., Turner, B. E., Morris, M.
Palmer, P. 1976, Ap. J.(L), 205, L15.

FIGURE CAPTIONS

Figure 1 shows the CI (upper) and ^{13}CO (lower) spectra of AFGL 2688.

ADDRESSES FOR AUTHORS:

C. A. Beichman---264-338, Jet Propulsion Laboratory, 4800 Oak Grove Dr., Pasadena, CA 91109.

M. Frerking---168-327, Jet Propulsion Laboratory, 4800 Oak Grove Dr., Pasadena, CA, 91109.

P. J. Huggins---Dept. of Physics, New York University,
4 Washington Pl., New York, NY, 10003.

T. G. Phillips, Jocelyn Keene, C. Masson---320-47, California Institute of Technology, Pasadena, CA, 91125.

H. A. Wooten---National Radio Astronomy Observatory,
Edgemont Rd., Charlottesville, VA, 22901.

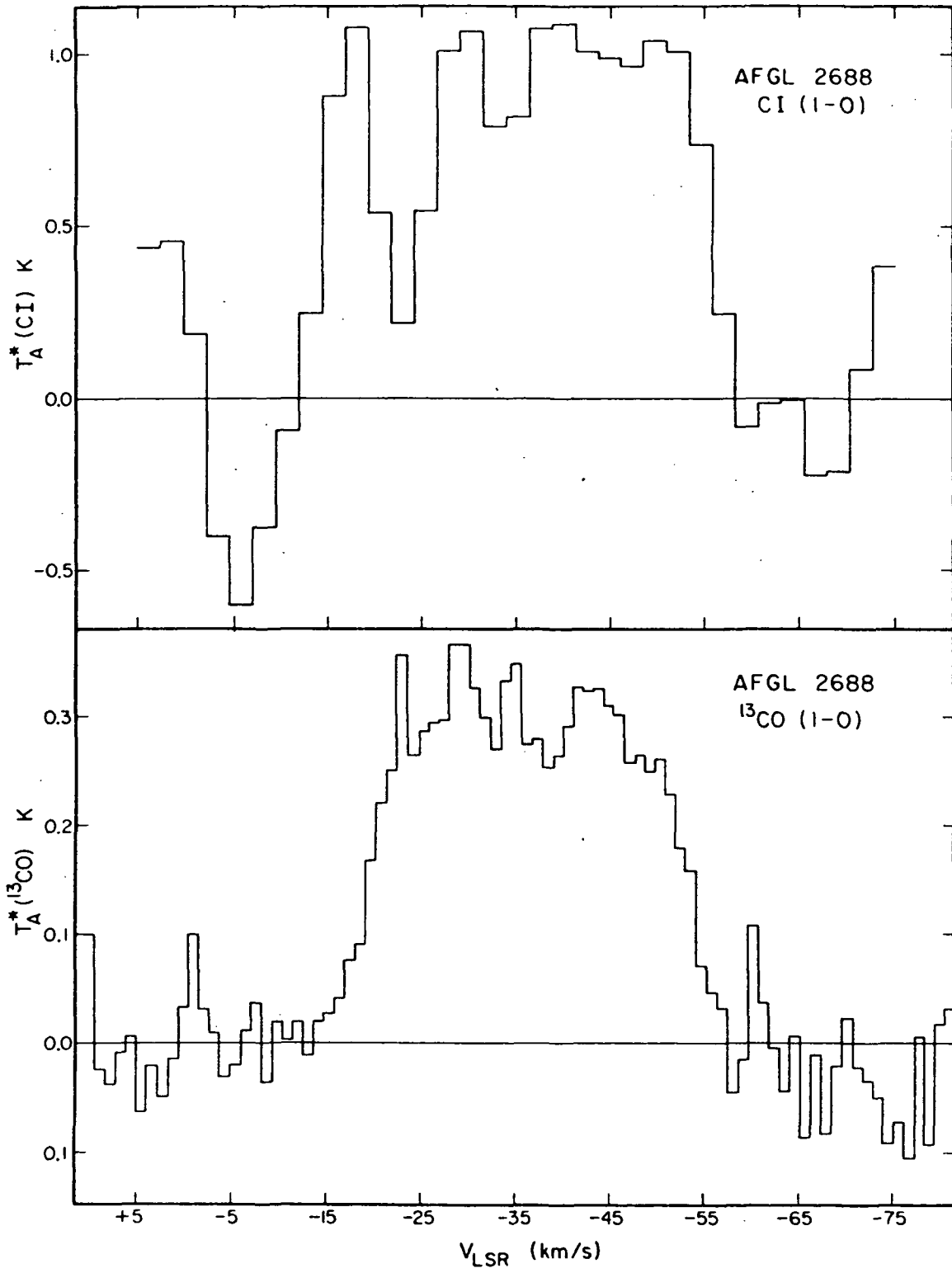

Fig. 1

1. Report No. NASA TM-84360	2. Government Accession No.	3. Recipient's Catalog No.	
4. Title and Subtitle NEUTRAL CARBON IN THE EGG NEBULA (AFGL 2688)		5. Report Date April 1983	6. Performing Organization Code
		8. Performing Organization Report No. A-9322	10. Work Unit No. 352-02-03
7. Author(s) C. A. Beichman,* J. Keene,** T. G. Phillips,** P. J. Huggins,† H. A. Wootten,** C. Masson,** and M. A. Frerking*		11. Contract or Grant No.	13. Type of Report and Period Covered Technical Memorandum
9. Performing Organization Name and Address *Jet Propulsion Laboratory, Calif. Institute of Technology, Pasadena, Calif., **Calif. Institute of Technology, Pasadena, Calif., †New York University, New York, New York		14. Sponsoring Agency Code	
		12. Sponsoring Agency Name and Address National Aeronautics and Space Administration Washington, D.C. 20546	
15. Supplementary Notes Preprint Series #11. Supported by NASA grants. Point of Contact: L. C. Haughney, Ames Research Center, M/S 211-12, Moffett Field, Calif. 94035, (415) 965-5339, FTS 448-5339			
16. Abstract Observations have been made in the 492 GHz line of atomic carbon (C I) toward eight evolved stars with circumstellar envelopes. The observations of one star, AFGL 2688, also known as the Egg Nebula, yielded the detection of a line ($T_A^* \sim 0.9$ K) with a central velocity and width that are the same, within the uncertainties, as those measured in CO. The large CI/CO abun- dance ratio implied by the data for AFGL 2688 suggests that $[C]/[O] > 4$ in this object. Upper limits to the CI/CO ratio are reported for seven other stars, including IRC+10216 and NGC 7027.			
17. Key Words (Suggested by Author(s)) Astronomy Nebulae-abundance Nebulae-H II regions Infrared-spectra		18. Distribution Statement Unlimited Subject Category - 89	
19. Security Classif. (of this report) Unclassified	20. Security Classif. (of this page) Unclassified	21. No. of Pages 27	22. Price* A03