

NASA-CR-168318

NASA-CR-168318
19840021288

DOE/NASA/0354-1
NASA CR-168318
AST Report 84-1808

Wind Turbine Generator Interaction With Conventional Diesel Generators On Block Island, Rhode Island

Volume I—Executive Summary

V. F. Wilreker, P. H. Stiller,
G. W. Scott, V. J. Kruse, and R. F. Smith
Advanced Systems Technology
Westinghouse Electric Corporation
Pittsburgh, Pennsylvania 15235

February 1984

Prepared for
NATIONAL AERONAUTICS AND SPACE ADMINISTRATION
Lewis Research Center
Cleveland, Ohio 44135
Under Contract DEN 3-354

for
U.S. DEPARTMENT OF ENERGY
Conservation and Renewable Energy
Wind Energy Technology Division
Under Interagency Agreement DE-AI01-76ET20320

LIBRARY COPY

SEP 8 1984

LANGLEY RESEARCH CENTER
LIBRARY, NASA
HAMPTON, VIRGINIA

DISCLAIMER

This report was prepared as an account of work sponsored by an agency of the United States Government. Neither the United States Government nor any agency thereof, nor any of their employees, makes any warranty, express or implied, or assumes any legal liability or responsibility for the accuracy, completeness, or usefulness of any information, apparatus, product, or process disclosed, or represents that its use would not infringe privately owned rights. Reference herein to any specific commercial product, process, or service by trade name, trademark, manufacturer, or otherwise, does not necessarily constitute or imply its endorsement, recommendation, or favoring by the United States Government or any agency thereof. The views and opinions of authors expressed herein do not necessarily state or reflect those of the United States Government or any agency thereof.

Printed in the United States of America

Available from

National Technical Information Service
U.S. Department of Commerce
5285 Port Royal Road
Springfield, VA 22161

NTIS price codes¹

Printed copy: A03
Microfiche copy: A01

¹Codes are used for pricing all publications. The code is determined by the number of pages in the publication. Information pertaining to the pricing codes can be found in the current issues of the following publications, which are generally available in most libraries: *Energy Research Abstracts (ERA)*; *Government Reports Announcements and Index (GRA and I)*; *Scientific and Technical Abstract Reports (STAR)*; and publication, NTIS-PR-360 available from NTIS at the above address.

18 1 1 RN/NASA-CR-168318

DISPLAY 18/2/1

84N29357** ISSUE 19 PAGE 3050 CATEGORY 44 RPT#: NASA-CR-168318
DOE/NASA/0354-1 MAS 1.26:168318 AST-84-1808 CNT#: DEM3-275 DEM3-354
DE-AI01-76ET-20320 84/02/00 47 PAGES UNCLASSIFIED DOCUMENT

UTTL: Wind turbine generator interaction with conventional diesel generators on
Block Island, Rhode Island. Volume 1: Executive summary TLSP: Final
Report

AUTH: A/WILREKER, V. F.; B/STILLER, P. H.; C/SCOTT, G. W.; D/KRUSE, V. J.;
E/SMITH, R. F.

CORP: Westinghouse Electric Corp., Pittsburgh, Pa. CSS: (Advanced Systems
Technology.) AVAIL. NTIS SAP: HC A03/MF A01

MAJS: /*DIESEL ENGINES/*DYNAMIC CHARACTERISTICS/*ELECTRIC GENERATORS/*ENERGY
CONVERSION/*FUEL CONSUMPTION/*WIND TURBINES

MINS: / DATA ACQUISITION/ INTERACTIONS/ POWER FACTOR CONTROLLERS/ RHODE ISLAND/
UTILITIES

ABA: A. R. H.

ABS: Primary results are summarized for a three-part study involving the
effects of connecting a MOD-0A wind turbine generator to an isolated
diesel power system. The MOD-0A installation considered was the third of
four experimental nominal 200 kW wind turbines connected to various
utilities under the Federal Wind Energy Program and was characterized by
the highest wind energy penetration levels of four sites. The study
analyses address: fuel displacement, dynamic interaction, and three modes

ENTER:

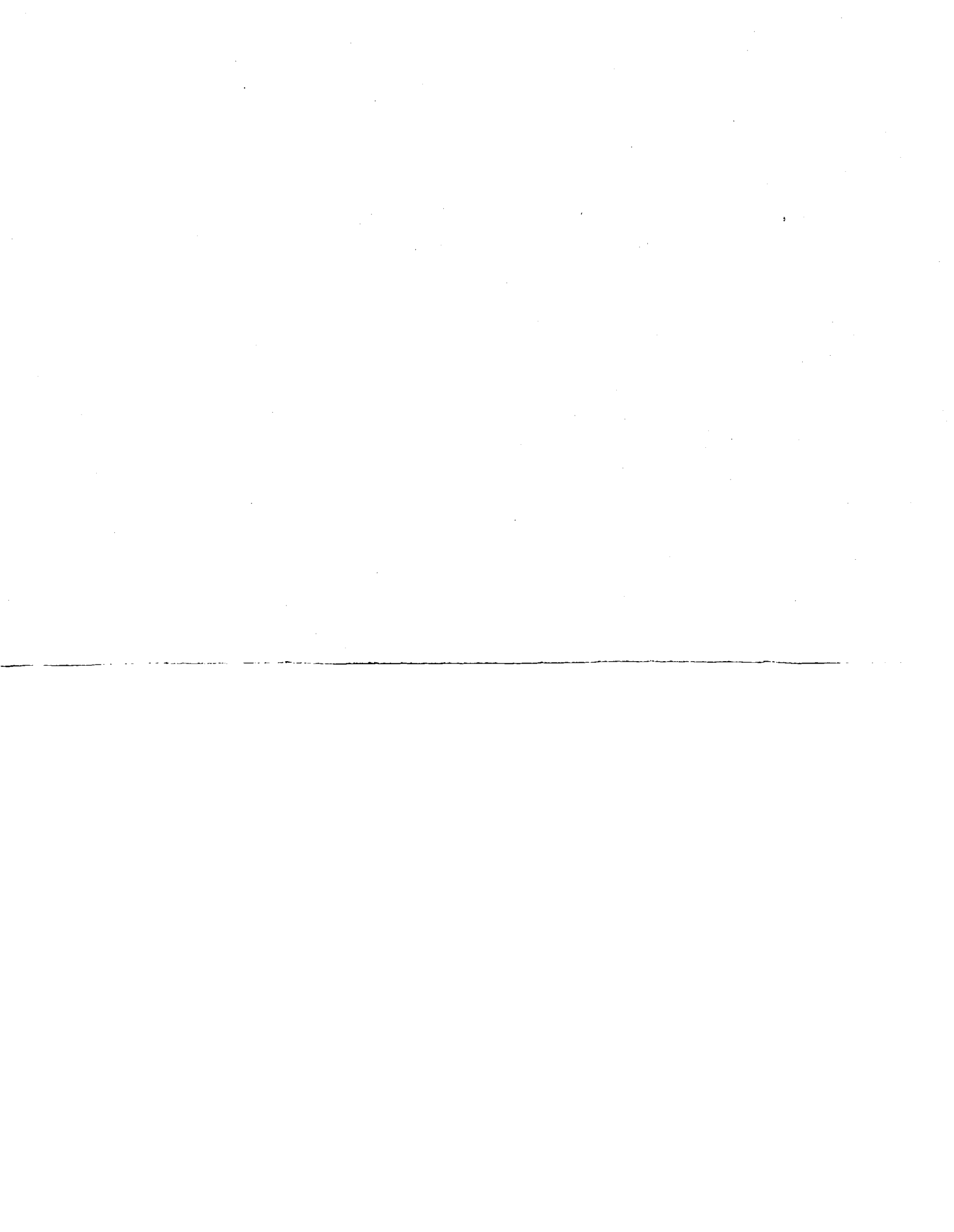

DOE/NASA/0354-1
NASA CR-168318
AST Report 84-1808

Wind Turbine Generator Interaction With Conventional Diesel Generators On Block Island, Rhode Island

Volume I—Executive Summary

V. F. Wilreker, P. H. Stiller,
G. W. Scott, V. J. Kruse, and R. F. Smith
Advanced Systems Technology
Westinghouse Electric Corporation

February 1984

Prepared for
NATIONAL AERONAUTICS AND SPACE ADMINISTRATION
Lewis Research Center
Cleveland, Ohio
Under Contract DEN 3-354

for
**U.S. DEPARTMENT OF ENERGY
Conservation and Renewable Energy
Wind Energy Technology Division**

NS4-29357#

TABLE OF CONTENTS

	<u>Page No.</u>
SUMMARY AND CONCLUSIONS	v
1.0 BLOCK ISLAND UTILITY AND SITE CHARACTERISTICS	1
1.1 Load Characteristics	1
1.2 Operational Considerations	1
1.3 Data Acquisition	2
2.0 ENERGY CONVERSION ANALYSIS	3
2.1 Prospective Fuel Displacement Properties of the WTG	3
2.2 Diesel Efficiency Characteristics	4
2.3 Throttle Activity Effects	5
2.4 Actual Fuel Displacement Results	6
3.0 DYNAMIC INTERACTION	7
3.1 Modes of Operation Examined for Dynamic Interaction	7
3.2 Results of Dynamic Interaction Data Measurement Analysis	8
3.3 Linear Modeling Analysis	13
4.0 REACTIVE POWER CONTROL MODES	15
4.1 Basic Characteristics of Each Type of Control	15
4.2 Results of Data Measurement Analysis	15
4.3 Simulation Model Analysis	18

APPENDIX	20
"Measured Effect of Wind Generation on the Fuel Consumption of an Isolated Diesel Power System"	21
"Wind Turbine Generator Interaction with Diesel Generators on an Isolated Diesel System"	26
"Measured Effects of Wind Turbine Reactive Power Control on an Isolated Utility"	31
REFERENCES	37

SUMMARY AND CONCLUSIONS

This report summarizes the primary results of a three-part study involving the effects of connecting a MOD-OA wind turbine generator to an isolated diesel power system. The subject utility is that owned and operated by the Block Island Power Company (BIPCO). The MOD-OA installation here was the third of four experimental nominal 200 kW wind turbines connected to various utilities under the Federal Wind Energy Program. The BIPCO installation was characterized by the highest wind energy penetration levels of the four sites and, as such, was adjudged the best candidate for conducting the data acquisition and analysis effort that is the subject of this study.

The three-phases of the study analysis address: 1) fuel displacement, 2) dynamic interaction, and 3) three modes of reactive power control. These analyses all have as their basis the results of the data acquisition program conducted during 1982 from February into April on Block Island, Rhode Island.

The major conclusions of the study are as follows.

Phase I - Fuel Study

- The rate of fuel displacement by the experimental MOD-OA on Block Island is equal to the incremental fuel consumption rate of the diesel unit on load frequency control.
- Diesel engine throttle activity resulting from wind gusts which change the wind turbine output does not significantly influence fuel consumption.
- The MOD-OA wind turbine on Block Island, Rhode Island displaced 25,700 lbs. of the diesel fuel during the test period, representing a calculated reduction in fuel consumption of 6.7% while generating 11% of the total electrical energy.

Phase II - Dynamic Interaction

- Power and voltage transients due to MOD-OA normal startup and shutdown were of insignificant magnitude as were the cyclic power variations due to the tower-shadow effect.
- MOD-OA power fluctuations under fixed pitch operation were compensated for by the diesel governor control resulting in system frequency and voltage variations no greater than present without the MOD-OA.
- MOD-OA operation under variable pitch (constant power) control showed an increased amplitude low frequency oscillation (.9 rad/s) that was still within acceptable limits. Linear analysis demonstrated the oscillation amplitude was reducible by changes in diesel governor and blade pitch control settings.

Phase III - Reactive Power Control

- No significant differences in frequency or voltage behavior were found among any of the three control modes. A simulation study indicated that constant power factor control provided the best transient stability and constant voltage control the least.
- The low frequency reactive var component caused by the combination of the MOD-OA, system load and wind dynamics was found to flow from generators under constant voltage control to those under either fixed field or constant power factor control.
- Constant var control was preferred because of its ability to provide a smooth source of reactive power and still exhibit good transient stability.

Overall Study Conclusion

In terms of fuel savings, the acceptability of the dynamics interaction effects observed and the sufficiency of the excitation control, it is concluded that wind turbine generation is an acceptable option even under adverse isolated utility operating conditions.

1.0 BLOCK ISLAND UTILITY AND SITE CHARACTERISTICS

1.1 Load Characteristics

During the three months data-gathering effort, the Block Island Power Company (BIPCO) was in the winter configuration wherein only two diesel units were in operation -- normally one on fixed throttle and the other governor controlled. A typical weekly power demand curve is the following.

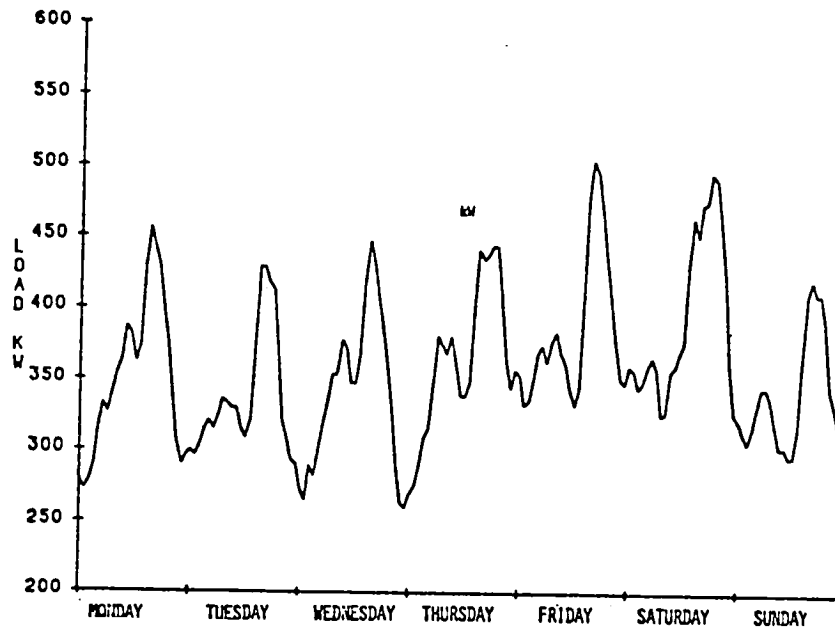

As seen, the minimum load extends down to 250 kW so that for the 150 kW MOD-OA rating, the wind power penetration is some 60%.

1.2 Operational Considerations

The following operational constraints were applied to the BIPCO system.

1. Nominal MOD-OA rating of 200 kW (at 40 rev/min) was reduced to 150 kW (at 31.5 rev/min) so that overall energy capture was maximized for the particular wind regime on Block Island.

2. WTG turned off from 12:00 a.m. to 8:00 a.m. to avoid operating governed diesel near zero load which because of low engine temperature would risk damage fire due to oil accumulation in exhaust stack.
3. Utilization of WTG power restricted because of operational constraints unique to BIPCO utility.

1.3 Data Acquisition

Some 40 variables were recorded on magnetic FM tape with 8 of these going to an on-line strip chart recorder for immediate monitoring. Digital processing was also part of the overall operation. A pictorial broadly describing the data acquisition system appears below:

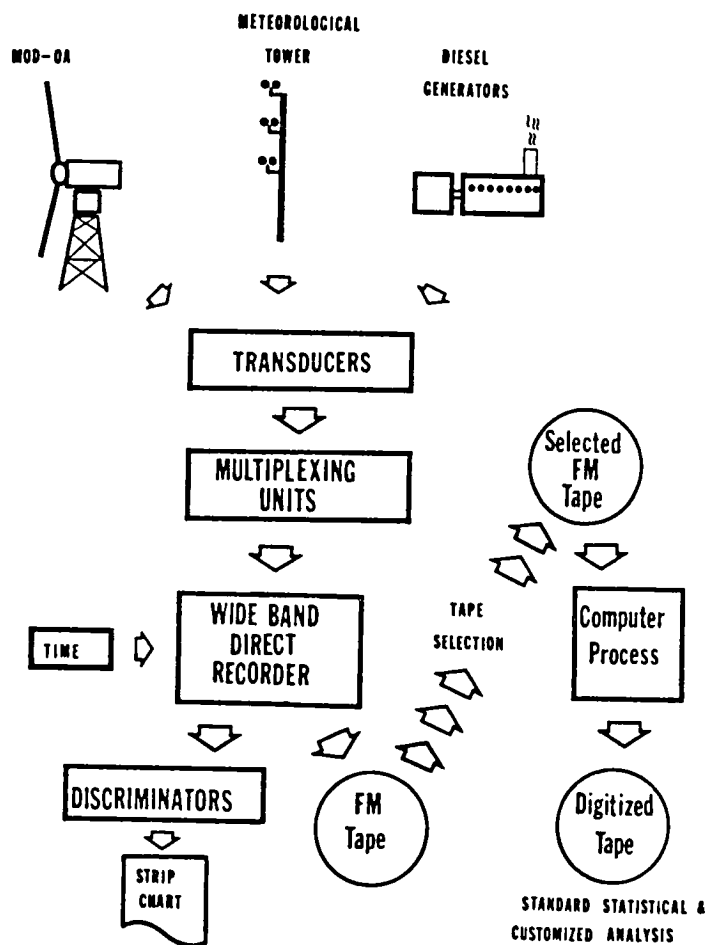

2.0 ENERGY CONVERSION ANALYSIS

Quantifying the effective fuel displacement (savings) due to MOD-OA operation is the principal objective of this analysis. Beginning with an analysis of prospective factors affecting fuel displacement, each is evaluated in terms of the results provided by the data analysis.

2.1 Prospective Fuel Displacement Properties of the WTG

Three major postulated factors that determine the difference between fuel displaced based on gross wind turbine electrical output power and the actual fuel displaced are given by the following pie chart.

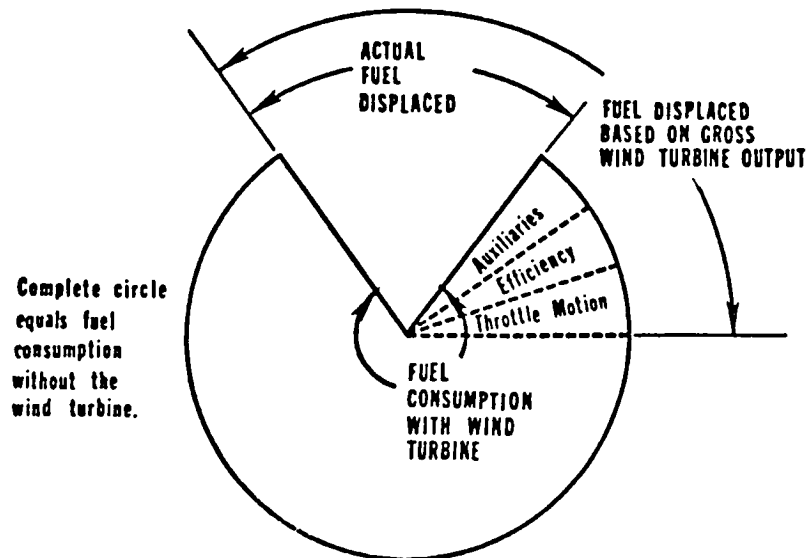

The most obvious of these components is the "efficiency" segment which naturally must be non-zero. The designation "auxiliaries" relates to the fact that the yaw control motor and fans consume power. "Throttle motion" is an efficiency component which theorizes that rapidly fluctuating diesel throttle operation will be less efficient than constant or slowly varying throttle operation.

2.2 Diesel Efficiency Characteristics

Measurement of fuel mass flow rate vs. electrical power output on a 15 minute average basis yields for the three diesel units:

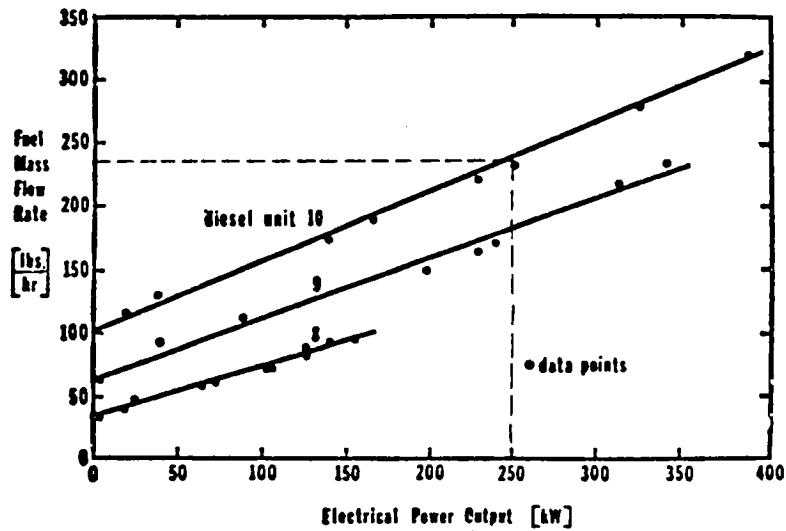

This observed linear characteristic -- fuel flow = incremental fuel flow x kW + idle fuel flow is converted to a diesel efficiency characteristic given by:

$$\text{Efficiency} = \frac{\text{kWh output}}{\text{time} \times \text{idle fuel flow} + \text{kWh} \times \text{incremental fuel flow}}$$

The diesel efficiency resulting are shown below:

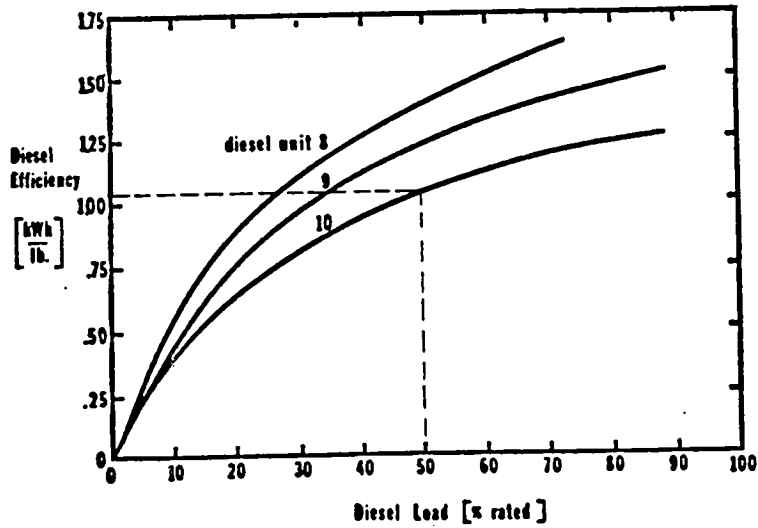

2.3 Throttle Activity Effects

Wind power variations translate to corresponding throttle variation on the governor controlled diesel(s). A measure of increased fuel consumption vs. throttle speed using a .5 second interval between data points produces:

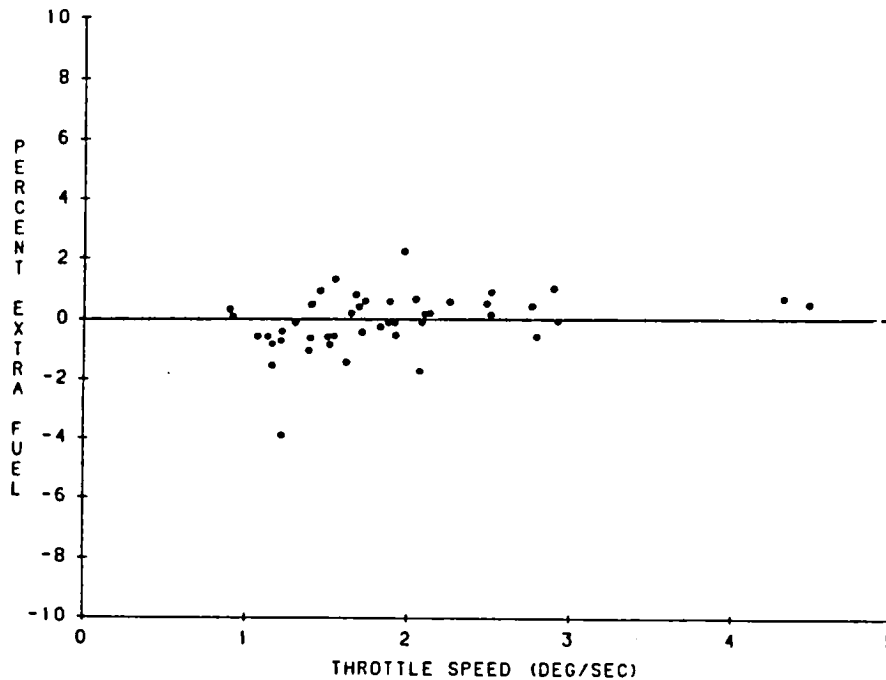

This plot, which surveys a 15-minute period of operation, is typical of other intervals examined and, as such, points out the fact that throttle activity is not a significant factor in fuel displacement.

2.4 Actual Fuel Displacement Result

The incremental fuel efficiencies of the particular diesel unit dictate the degree of fuel displacement. The results using diesel unit #9 show an incremental fuel consumption rate of .49 lbs. of fuel per kWh of net wind turbine power, while for #10 it is .57 lbs. per kWh.

The summary for unit #9 is given by the following table.

FUEL DISPLACEMENT RESULTS FOR TEST PERIOD

1) diesel unit (unit #9) incremental fuel consumption	0.49 lbs. fuel/kWh
2) gross MOD-0A wind turbine energy	56,900 kWh
3) MOD-0A wind turbine auxiliary energy	4,470 kWh
4) displaced fuel (line 2- line 3) x line 1	25,700 lbs. (3560 gal.)
5) gross energy generated (diesel and wind turbine)	496,000 kWh
6) total fuel burned	358,000 lbs. (49,800 gal.)

During the test period, the MOD-0A wind turbine generated 10.7% of the system electrical energy requirement and reduced fuel usage by 6.7%.

3.0 DYNAMIC INTERACTION

Identifying and quantifying any abnormal dynamic behavior when the MOD-OA WTG was connected to the Block Island utility is the principal objective of the analysis. Because of the high level of WTG penetration (up to 60%), the measured efforts are representative of the worst that would be expected on such a typical isolated diesel utility system.

3.1 Modes of Operation Examined for Dynamic Interaction

The four modes are:

1. Startup and synchronization: Variable blade pitch angle is controlled to bring wind alternator speed and angle to within desired limits so that closing in the breaker to the utility will result in acceptable voltage, frequency/power disturbances.
2. Shutdown and cutout: There are several types within this mode - (1) normal, (2) emergency, (3) critical. All have the function of removing the WTG from the utility. The first and second do it by initially ramping the WTG power to zero after which the breaker is opened (minimizing system disturbances), while, for the third, brakes are applied to the WTG and the breaker is opened immediately.
3. Fixed pitch operation: Rotor blades have an inclination from horizontal (pitch) so that maximum wind energy is converted -- blade pitch controller dynamics are absent.
4. Variable pitch (constant power) operation: Blade pitch controller dynamically controlling to an average power setpoint -- blade pitch controller dynamics are present.

3.2 Results of Dynamic Interaction Data Measurement Analysis

BIPCO Dynamic Characteristics without WTG

In combination with typical Block Island customer load variations, the governor control characteristics and diesel generator dynamics of those units used over the test period (#9 and #10) yield a fluctuating power system frequency illustrated in the following figure:

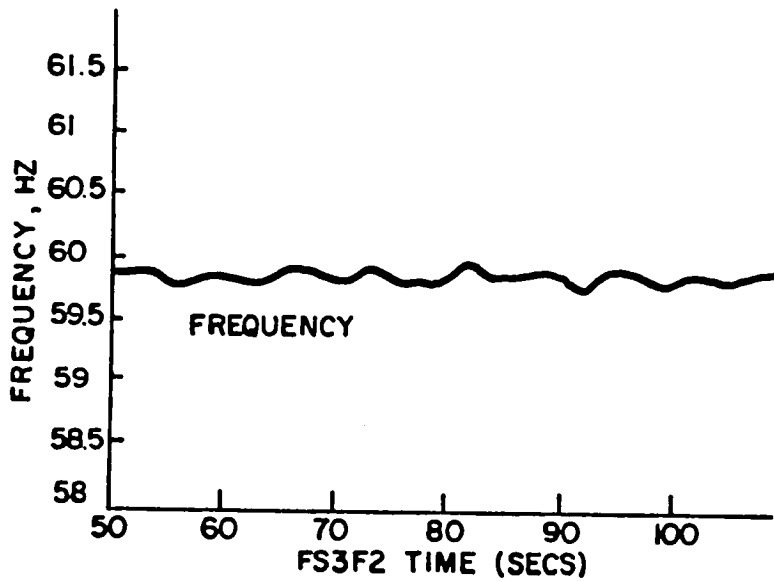

The major frequency component visible here is about 1 rad/s.

Dynamic Behavior During WTG Startup

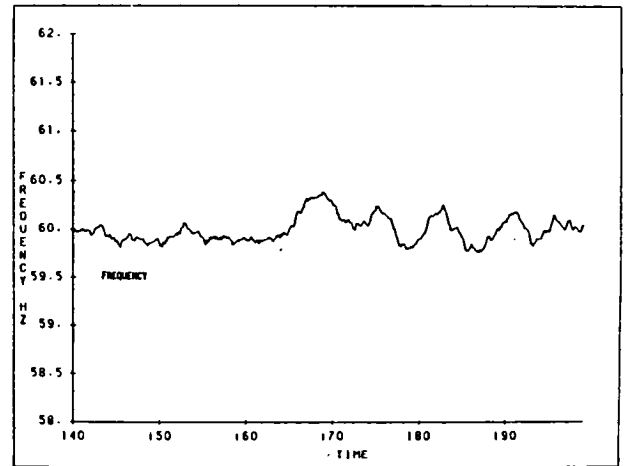
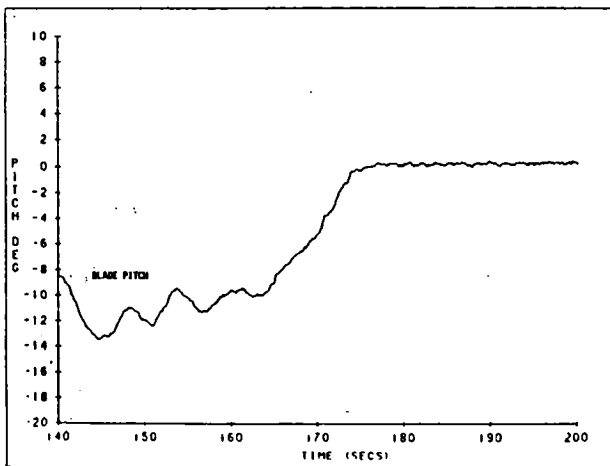
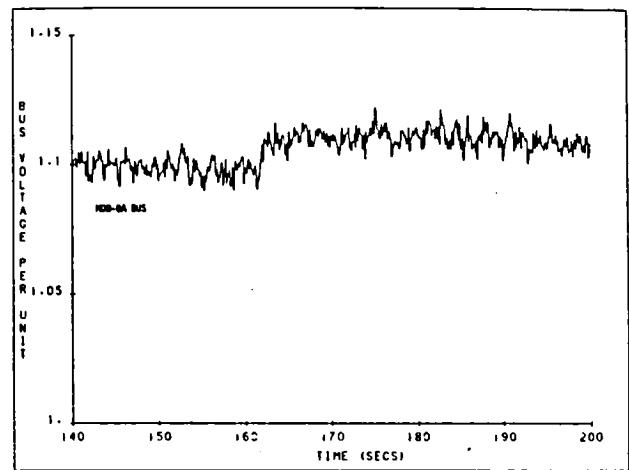
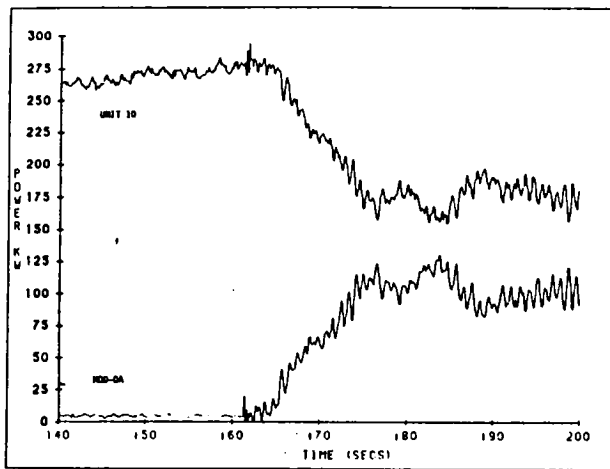

The preceding figure shows the following sequence of events: (1) blade pitch angle being varied to bring generator up to nominal speed, (2) tie-breaker closing (synchronizing) when microprocessor senses speed/phase requirement meet, (3) ramp up of WG power by changing pitch angle. The wind tower shadow effect is visible as a 6.6 rad/s variation and it is seen that the diesel governor control is compensating for this component as well as the low frequency wind induced variation.

Dynamic Behavior During Shutdown and Cutout

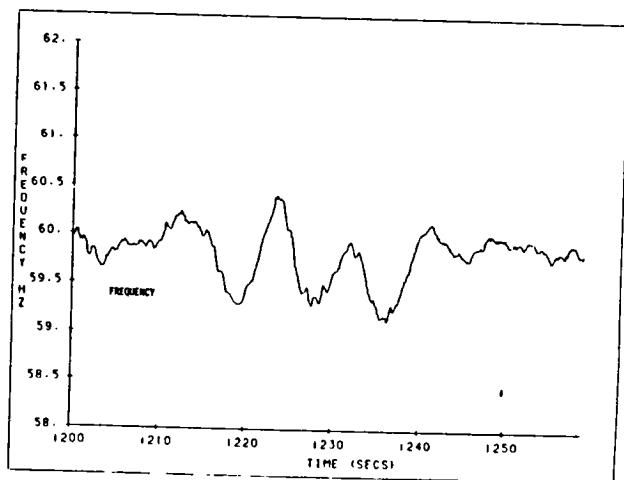
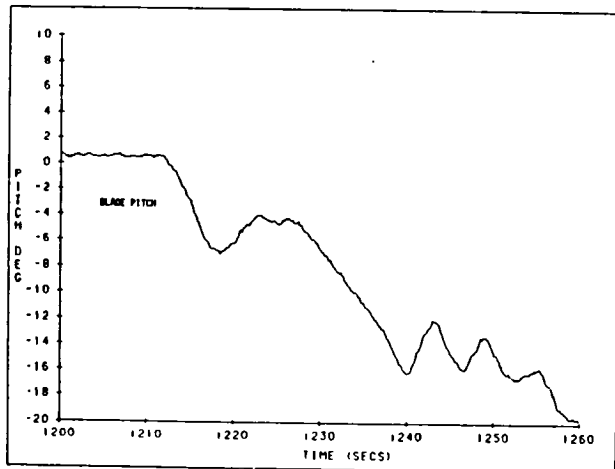
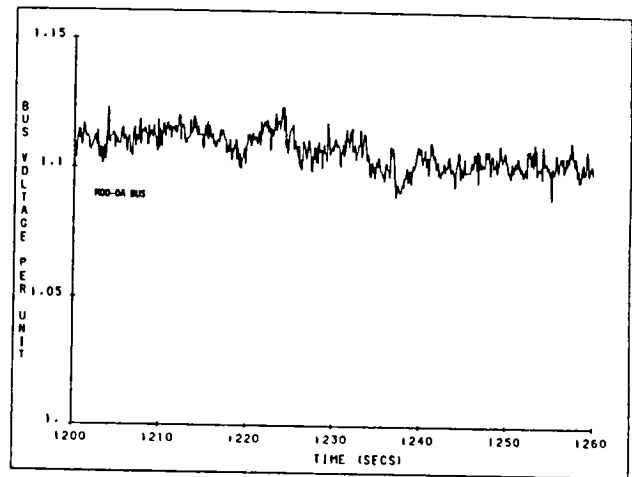
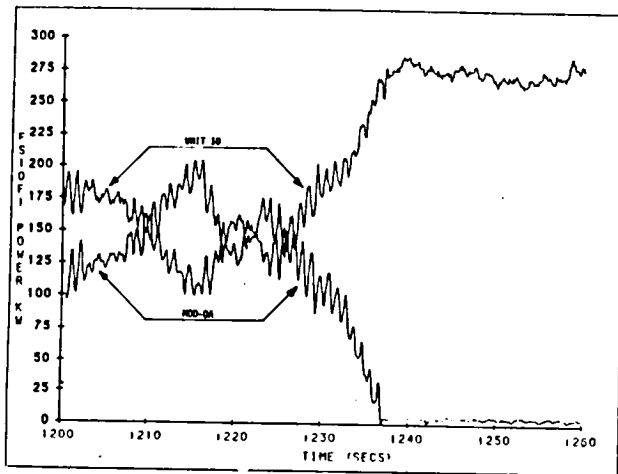

In the preceding figure the event sequence shown is: (1) fixed blade pitch operation followed by variable pitch due to sizable wind gust, (2) microprocessor signals shutdown and blade pitch ramped down bringing WTG power to zero at which time the tie-breaker opens.

Dynamic Interaction During Fixed Pitch Mode

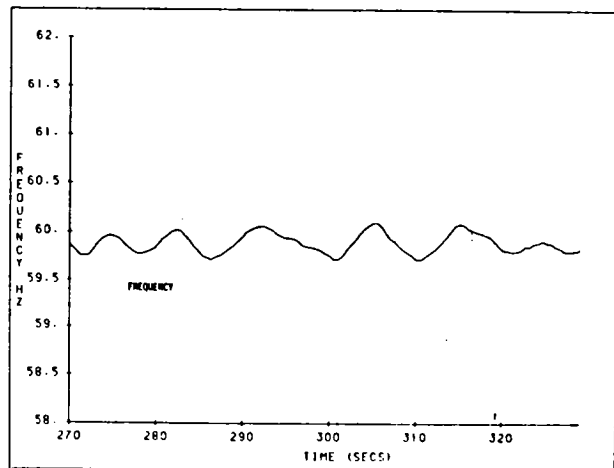
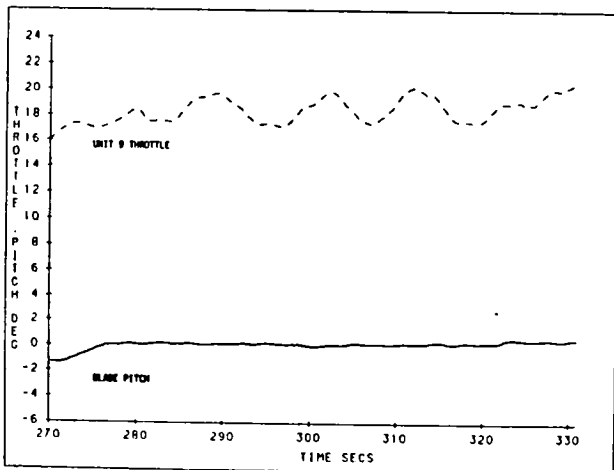
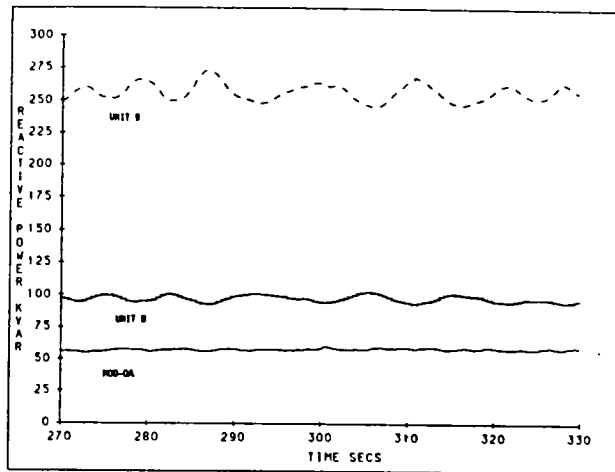
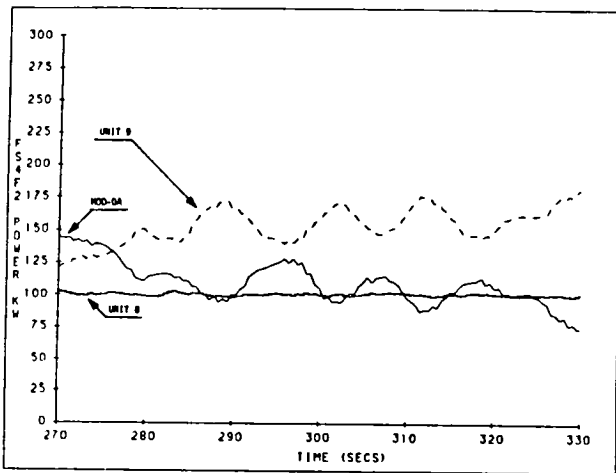

The preceding figure is an example of how system frequency behaves when the WTG blade pitch is fixed. Both the fluctuational load characteristics of BIPCO system and wind gust activity produce the frequency variations observed.

Dynamic Interaction During Variable Pitch (Constant Power) Mode

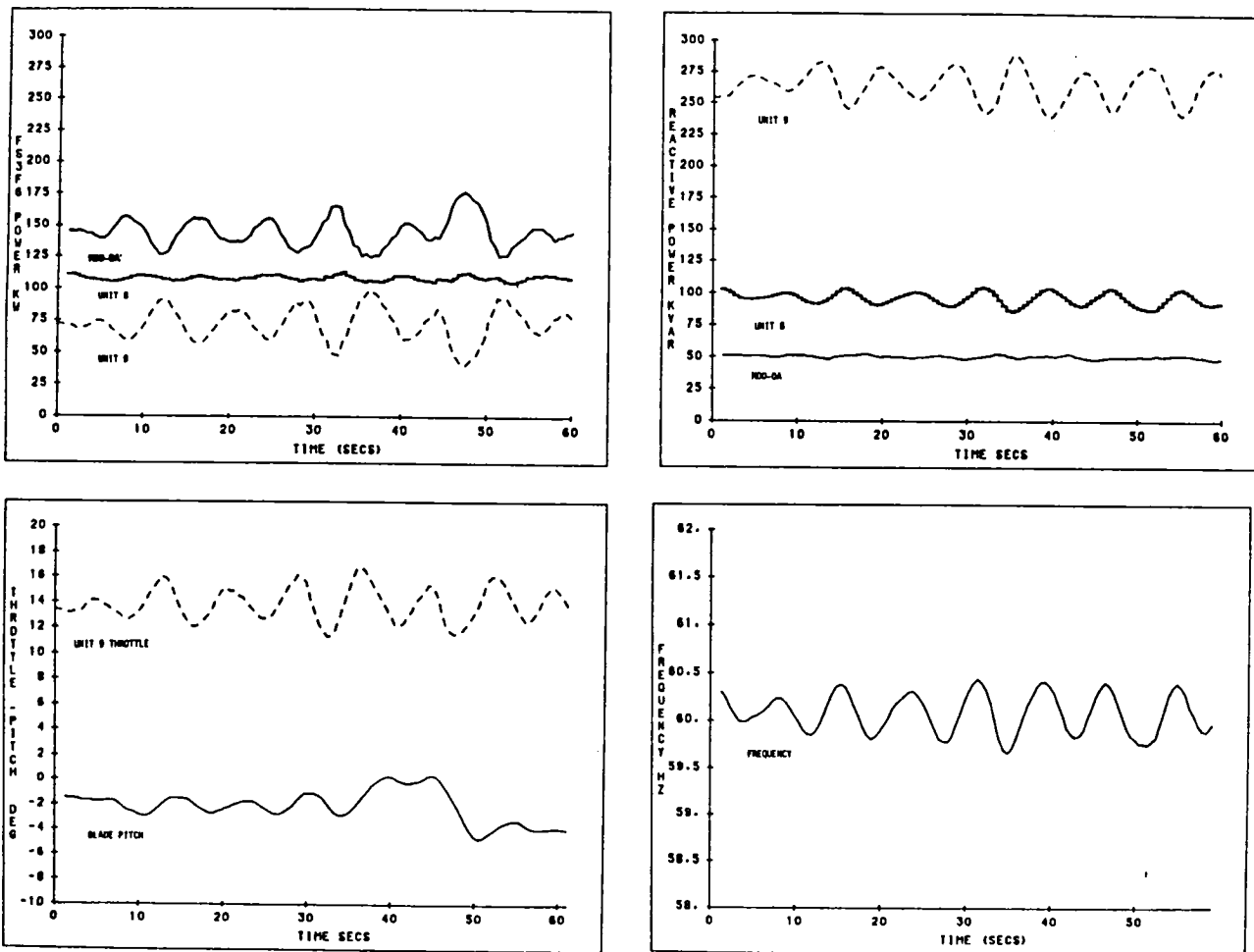

Variable blade pitch control exists over this interval. Low frequency oscillation of .9 rad/s is visible and is not correlated with wind profile thereby suggesting blade pitch control is either giving rise to or amplifying this component.

3.3 Linear Modeling Analysis

By means of a simple linearized model, the primary mechanism involved in the production/amplification of the low frequency component is identified. The starting point conceptual model is shown on the left below with the resulting operational transfer functions on the right:

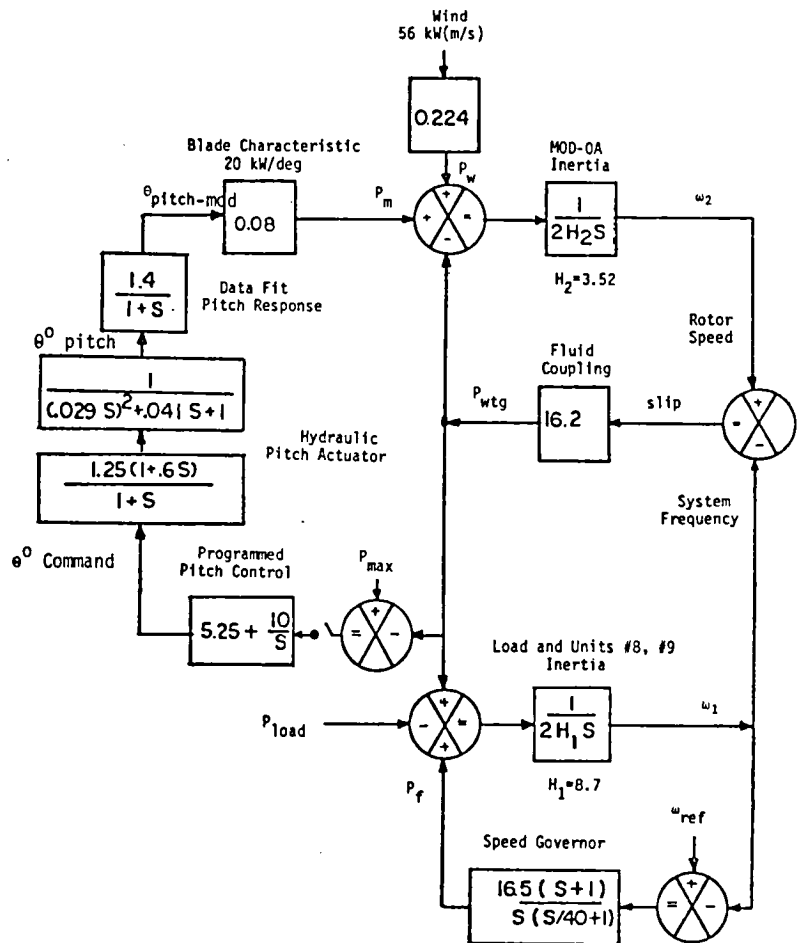
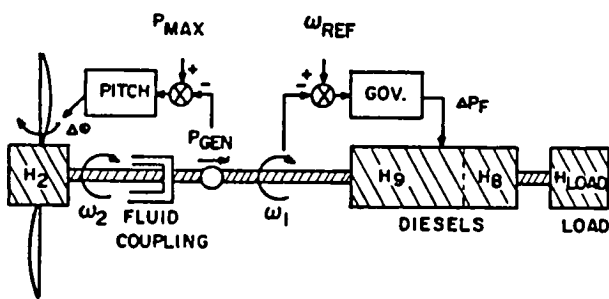

The responses to a step in wind power for several parametric changes to the model appear as follows:

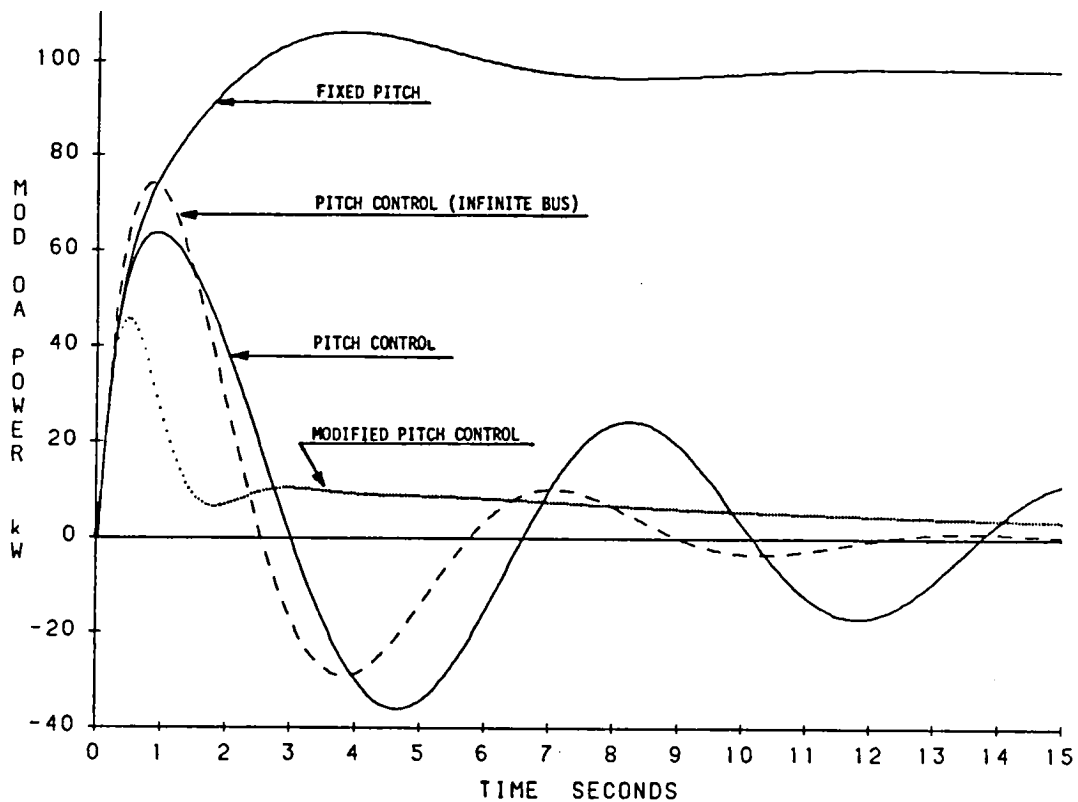

From the parameters given in the block diagram, it is seen that with pitch control active, the response is underdamped with a natural frequency corresponding to that in the data (approximately .9 rad/s). Shown also is the potential improvement when the programmed pitch proportional and integral control constants are multiplied by a factor of 8 and .4, respectively.

4.0 REACTIVE VOLT-AMPERE REGULATION MODES

Evaluating the effects of three methods of reactive power control (wind alternator field excitation control) is the primary purpose of this phase of the analysis. The solid-state regulator which drives a brushless exciter was adjustable to produce one of three control modes: (1) constant var, (2) constant power factor (PF), or (3) constant terminal voltage. The resulting configuration appears in the following figure:

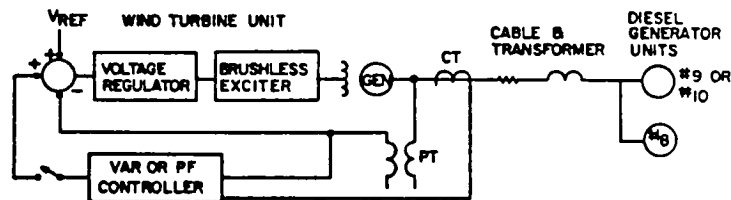

4.1 Basic Characteristics of Each Type of Control

1. Constant var - maintains a fixed value of reactive power out of WT alternator so as to provide synchronism and avoid an excessive lowering of the utility system voltage.
2. Constant PF - causes the WTG to appear electrically as a negative constant impedance load; normally has a higher synchronism capability than constant var method; voltage regulation poorest of three methods.
3. Constant voltage - synchronism capability worst of three methods; voltage regulation best of three.

4.2 Results of Data Measurement Analysis

Little difference was observed with regard to the effect on system voltage and frequency behavior among any of the three methods, making any of them usable insofar as the Block Island installation was concerned.

The following figure illustrates a significant phenomenon that interrelates the dynamic reactive power behavior among the diesel generators and WTG:

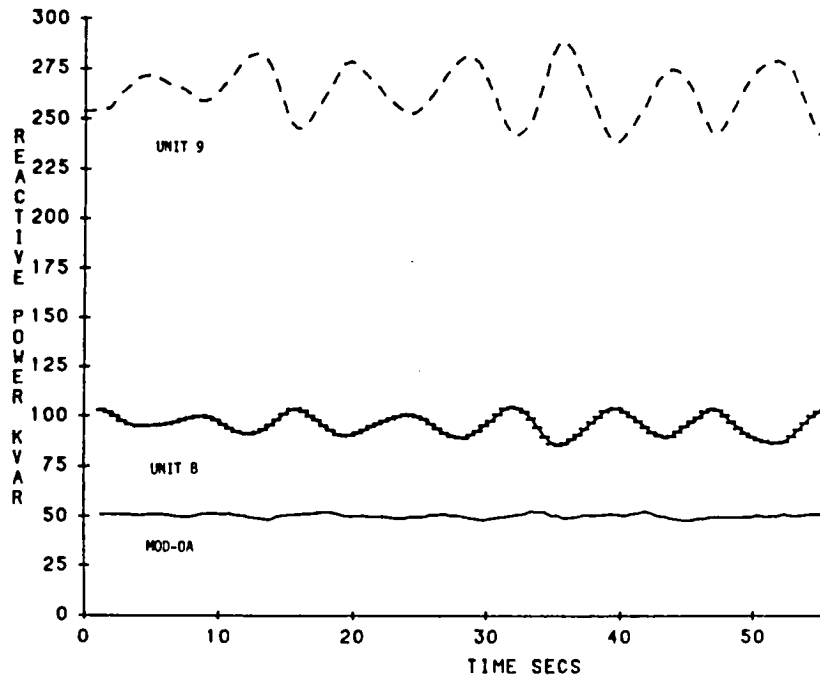

Here, the WTG is under constant var control, diesel unit #9 has governor control and constant voltage regulation, unit #8 has fixed throttle and fixed excitation. The oscillatory component is the nominal .9 rad/s that dominates under blade pitch control. It is seen that the constant var control and the WTG is quite effective in dynamically maintaining constant vars. The variational var requirement on the controlled diesel is increased because of the non-controlled diesel -- the latter appearing as an inductive load (var sink) to the variational component even though it is a steady-state var source.

When the MOD-OA alternator is being excited using constant power factor control, the following figure shows that it, like diesel unit #8, is absorbing the variational component by vars:

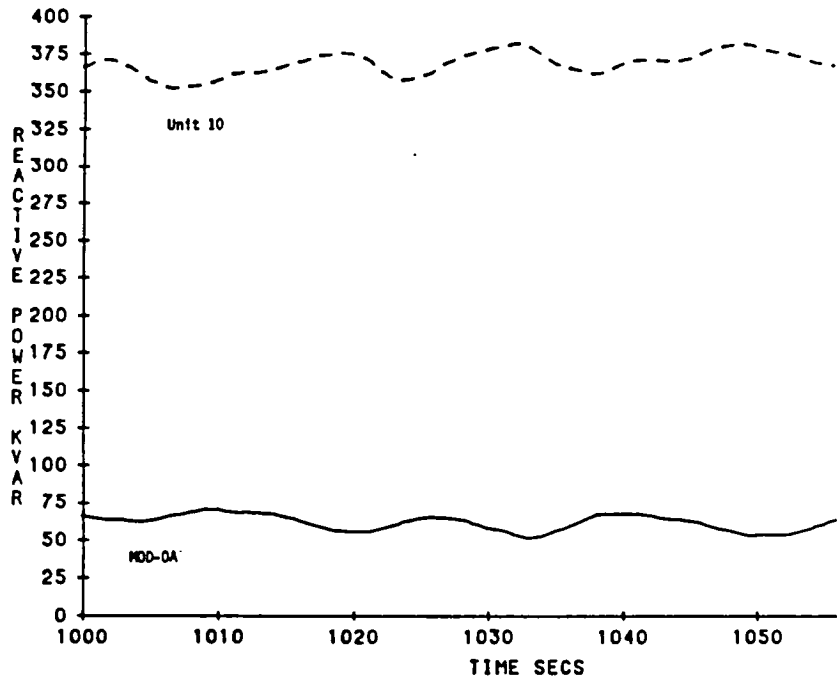

Under constant voltage control, the WTG and controlled diesel reactive power variational components are in phase as shown in the following figure:

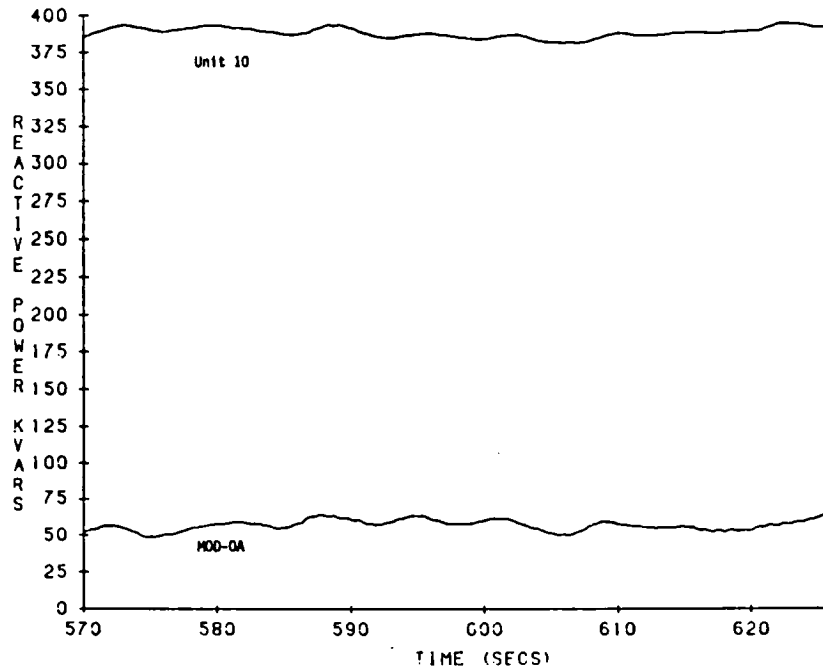

4.3 Simulation Model Analysis

The dynamic simulation of the WT alternator and the three methods of excitation was undertaken to enable a quantitative comparison of performance and also as a check to insure that no parasitic instabilities might exist which were possibly masked in the data measurement. The following figure shows the system simulated with the control parameters given:

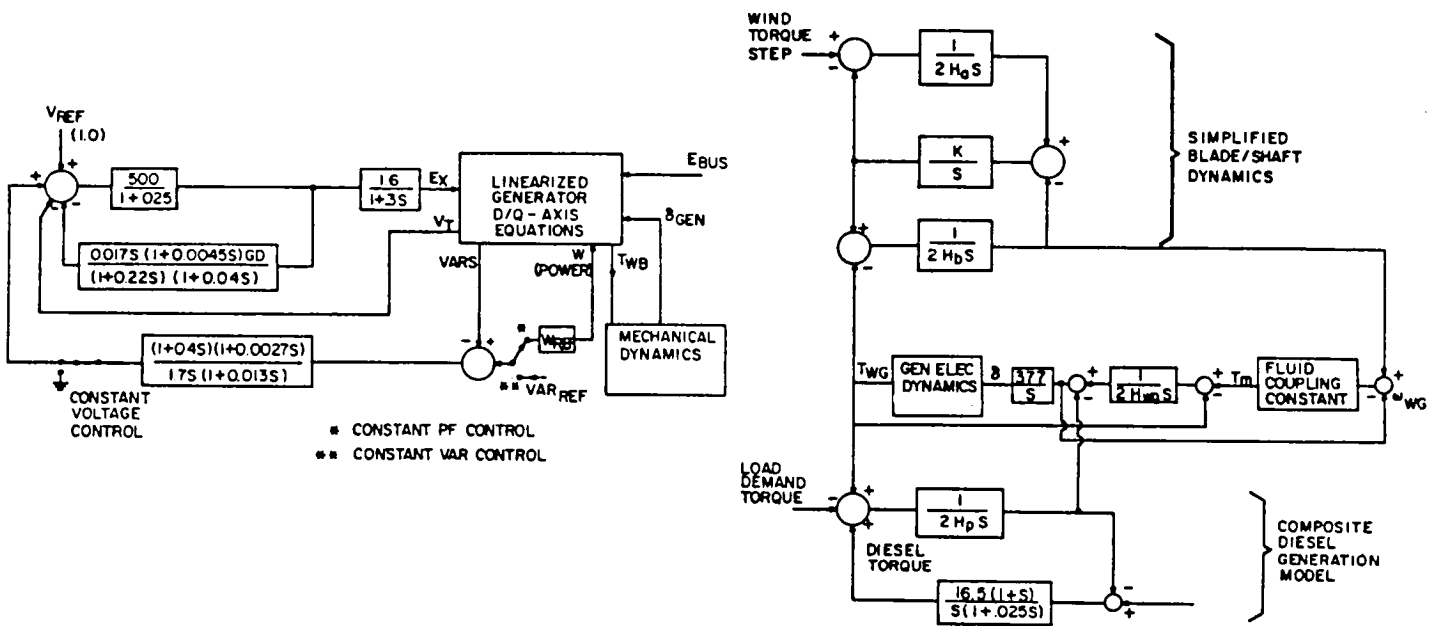

Shown below are the system angle and terminal voltage responses to a wind torque step applied to the model. These confirm the inherent behavior of the three types of control and show some of the higher order dynamic effects.

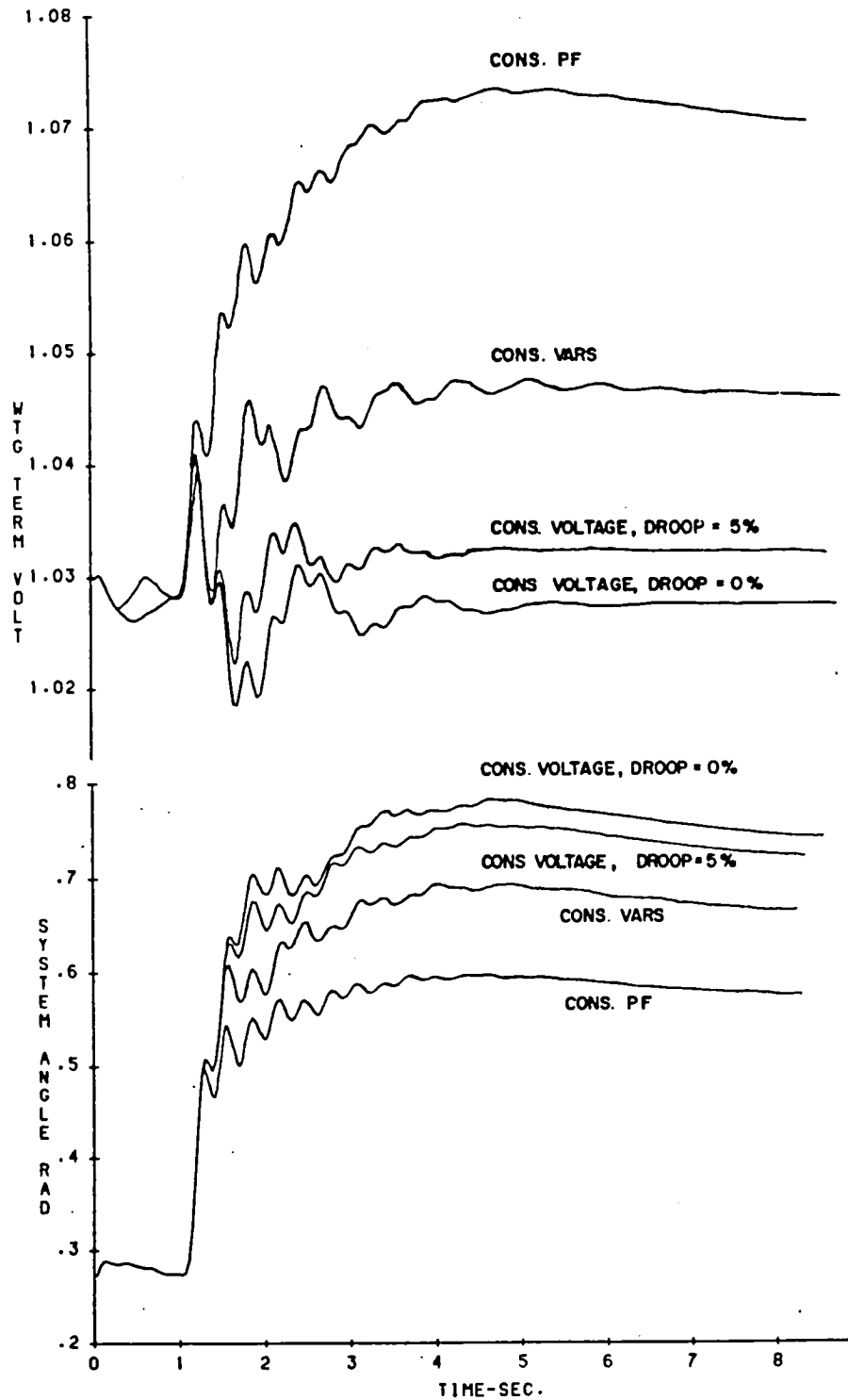

APPENDIX

In order to disseminate the results contained in this study (Volume II) and, in particular, make them more readily assimilable to the utility industry, the following three papers, each addressing one phase of the investigation, were written and presented at consecutive IEEE Power Engineering Society meetings.

1. "Measured Effect of Wind Generation on the Fuel Consumption of an Isolated Diesel Power System," by P. H. Stiller, G. W. Scott, and R. K. Shaltens. IEEE Transactions on Power Apparatus and Systems, Vol. PAS-102, pp. 1788-1792, June, 1983.
2. "Wind Turbine Generator Interaction with Diesel Generators on an Isolated Diesel System," by G. W. Scott, V. F. Wilreker, and R. K. Shaltens. 1983 IEEE Summer Power Meeting, Paper #83SM 329-0.
3. "Measured Effects of Wind Turbine Reactive Power Control on an Isolated Utility," by R. F. Smith, V. F. Wilreker, and R. K. Shaltens. 1984 IEEE Winter Power Meeting, Paper #84WM 056-8.

A fourth paper, integrating and summarizing the information in the three IEEE papers was presented at the 1984 American Power Conference. Copies of the IEEE papers may be found on the following pages. Since the American Power Conference paper was a summary paper containing essentially the same information as the preceding Executive Summary text, it is not included in this appendix.

MEASURED EFFECT OF WIND GENERATION ON THE FUEL CONSUMPTION OF AN ISOLATED DIESEL POWER SYSTEM

P. H. Stiller
Member, IEEE

G. W. Scott
Member, IEEE

R. K. Shaltens

Advanced Systems Technology
Westinghouse Electric Corporation
Pittsburgh, PA

NASA Lewis Research Center
Cleveland, Ohio

Abstract – The Block Island Power Company (BIPCO), on Block Island, Rhode Island, operates an isolated electric power system consisting of diesel generation and an experimental wind turbine. The 150-kW wind turbine, designated MOD-OA by the U.S. Department of Energy is typically operated in parallel with two diesel generators to serve an average winter load of 350 kW. Wind generation serves up to 60% of the system demand depending on wind speed and total system load. Results of diesel fuel consumption measurements are given for the diesel units operated in parallel with the wind turbine and again without the wind turbine. The fuel consumption data are used to calculate the amount of fuel displaced by wind energy. Results indicate that the wind turbine displaced 25,700 lbs. of the diesel fuel during the test period, representing a calculated reduction in fuel consumption of 6.7% while generating 11% of the total electrical energy. The amount of displaced fuel depends on operating conditions and system load. It is also shown that diesel engine throttle activity resulting from wind gusts which rapidly change the wind turbine output do not significantly influence fuel consumption.

INTRODUCTION

The Federal Wind Energy Program was established to enable research and development on various applications of wind energy systems. The program was originally administered by the National Science Foundation and is currently directed and funded by the U.S. Department of Energy. One phase of the program involves the design, fabrication, and experimental operation of large horizontal axis wind turbines. This part of the program is managed by the Lewis Research Center of the National Aeronautics and Space Administration. The first wind turbine generators to be placed into utility operation under this program¹ were four, 200-kW horizontal axis machines designated MOD-OA. A MOD-OA machine was installed on Block Island, Rhode Island² in mid-1979, and was modified for 150-kW maximum output in October, 1980. The experimental wind turbine was operated until June, 1982 in parallel with existing diesel generation owned by Block Island Power Company (BIPCO).

The purpose of the MOD-OA experimental installation was to obtain early operation and performance data while gaining experience in the operation of a large wind turbine in various utility environments. The Block Island installation represents the highest wind penetration of all MOD-OA sites with wind generation serving up to 60% of the total system demand.

The objective of this fuel usage investigation was to quantify the influence of the wind turbine on diesel fuel consumption by determining the amount of fuel displaced by wind energy. In order to meet this objective, a complete instrumentation and data recording package was installed on three BIPCO diesel generators to monitor fuel flow rate, throttle position and various electrical parameters including generator power output. Data from the diesel instrumentation were simultaneously recorded with data from the wind turbine to study the influence of the wind turbine on fuel consumption.

Four (4) factors may influence diesel fuel consumption during parallel operation:

- 1) gross wind turbine output
- 2) wind turbine auxiliaries
- 3) change in diesel efficiency due to change in diesel load
- 4) reduced diesel efficiency due to throttle activity

Gross wind turbine output reduces overall diesel fuel consumption by contributing electrical energy without using fuel as illustrated in Figure 1.

Wind turbine auxiliaries including controls, instrumentation, heating and air conditioning increase diesel fuel consumption by using electrical energy that would otherwise serve utility customers. Auxiliary energy can be subtracted from the gross output and the result considered as the net wind turbine output.

Diesel efficiency under steady state conditions is primarily a function of load. Diesel engines are more efficient at higher loads.³ Increased wind generation drives diesel output down, causing the diesel to operate at lower efficiency and tending to increase specific fuel consumption as shown in Figure 1.

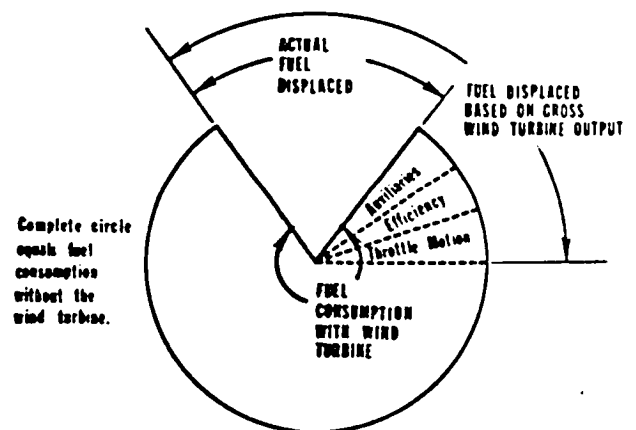

Figure 1 – Fuel Displaced by Wind Turbine

Wind gusts cause rapid wind turbine output fluctuations which are compensated by diesel output changes to hold constant frequency. Rapid or extreme diesel throttle variations can increase fuel consumption by degrading diesel efficiency. This is also illustrated in Figure 1.

Overall influence of the wind turbine on fuel consumption is determined by quantifying the four (4) factors to establish net displaced fuel. This quantity may be positive or negative.

BIPCO is an investor-owned electric utility which serves Block Island, Rhode Island. BIPCO is not electrically interconnected to any other utility. Major characteristics of the BIPCO system are summarized in Table 1.

Table 1

BIPCO Generation and Peak Load			
Peak load (summer 1981)			1,800 kW
(winter 1981)			450 kW
Active Generation Capacity			
(summer)	unit #9		400 kW
	#11		1,140 kW
	#12		1,000 kW
(winter)	unit #8		225 kW
	#9		400 kW
	#10		500 kW
System Heat Rate (ave. 5 years)			17,600 Btu/kWh
Fuel			No. 2 fuel oil

The principal economic base on Block Island is summer tourism. In 1982 there were 611 winter residents, engaging mainly in maintenance and construction for the summer season. Other activities include support of the labor force (restaurants, hotels) and some fishing. There is no heavy industry, so the electrical load is residential and commercial.

Electrical energy consumption during the winter months peaks in the morning and evening at 450 kW. Minimum winter load occurs during early morning hours (2-4 a.m.) and was observed to be 260 kW. The study was conducted during the winter months when wind turbine penetration is the highest.

BIPCO usually operates two diesel generators in parallel with the 150-kW MOD-OA wind turbine. This typically includes unit #8, a 225-kW diesel generator and unit #9, a 400-kW diesel generator. A 500-kW diesel generator (unit #10) is sometimes run in place of unit #9. The wind turbine is operated as wind is available. Typical unit loadings are given in Table 2.

Table 2

	Rating	Output	
		Low Wind	High Wind
diesel unit #8	225 kW	100 kW	100 kW
#9	400	225	100
#10	500	0	0
MOD-OA WT	150	25	150
System load		350	350

Unit #8 is run with constant throttle position (ungoverned) resulting in constant power output. Unit #9 maintains system frequency with a speed governor and also controls bus voltage with an active voltage regulator. Changes in wind turbine output are replaced by unit #9 output. The MOD-OA experimental wind turbine is automatically controlled by a microprocessor to generate power to a preset limit as wind is available.

FIELD MEASUREMENTS

The BIPCO diesel generators (units #8, 9, and 10) and MOD-OA wind turbine were instrumented for unattended data collection for a period of two months during the winter. Information about each of the diesel units was simultaneously recorded with wind turbine data on magnetic tape. Selected analog signals were also monitored with a strip chart recorder. Tapes and strip charts were then returned from the field for cataloging and analysis.

Instrumentation

An instrumentation package was installed on each of three (3) diesel generators used during the test period (units #8, 9, 10) and the MOD-OA turbine generator. Transducers converted measurements to analog signals. The data were recorded on magnetic tape using the DOE/NASA Engineering Data Acquisition System⁴ as shown in Figure 2. This recording system also includes strip chart monitors for selected channels. Quantities measured and recorded are summarized in Table 3 and Table 4.

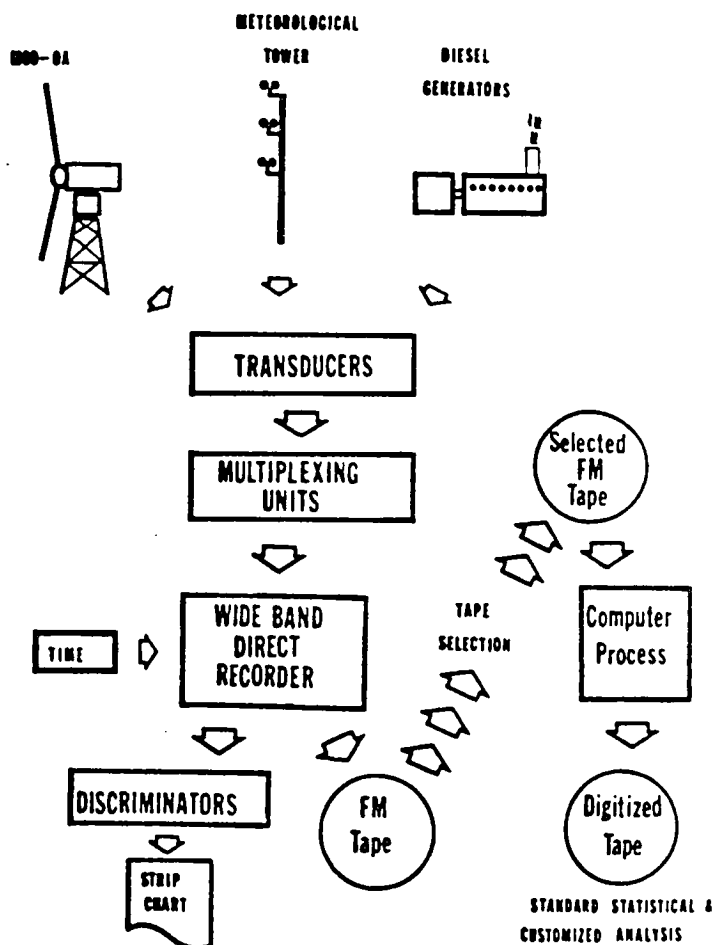

Figure 2 — DOE/NASA Engineering Data Acquisition System

Table 3
Quantities Measured and Recorded for
the Wind Turbine

<u>Parameter</u>	<u>Units</u>
real power	kilowatts
reactive power	kilovars
phase current	amperes
phase potential	volts
electrical frequency	hertz
blade pitch angle	degrees
rotational speed	rpm
nacelle direction	degrees
yaw torque	N·m
yaw error	degrees
blade bending movement	N·m
wind speed at hub	m/sec
wind speed at tower (30', 100', 150')	m/sec

Table 4
Quantities Measured and Recorded for
each Diesel Generator

<u>Parameter</u>	<u>Units</u>
real power	kilowatts
reactive power	kilovars
phase current	amperes
line potential	volts
field current	amperes (dc)
field potential	volts (dc)
electrical frequency	hertz
fuel mass flowrate	lbm/hour
diesel throttle position	degrees

Procedure

Data were continuously collected on diesel and wind turbine operation for two months. The information was automatically recorded with the exception of manual strip chart and magnetic tape changes for a few minutes every three days. A typical strip chart record is shown in Figure 3. Selected channels were recorded on the strip chart for monitoring purposes. A complete analog record was made on the magnetic tape.

During the test period, BIPCO personnel cooperated by shifting responsibility for load frequency control to various diesel units. This allowed collection of operating data for each diesel in base load and in frequency control modes. In base load operation, the diesel engine throttle does not change position. Under load frequency control, the engine throttle moves continuously in order to maintain system frequency. This comparison is important because the influence of throttle activity on fuel consumption is one factor to be evaluated.

ANALYSIS

The objective of this analysis was to determine the amount of diesel fuel displaced by the MOD-OA wind turbine on Block Island. The DOE/NASA Engineering Data Acquisition System was used to collect a comprehensive data base capable of supporting several different analyses.

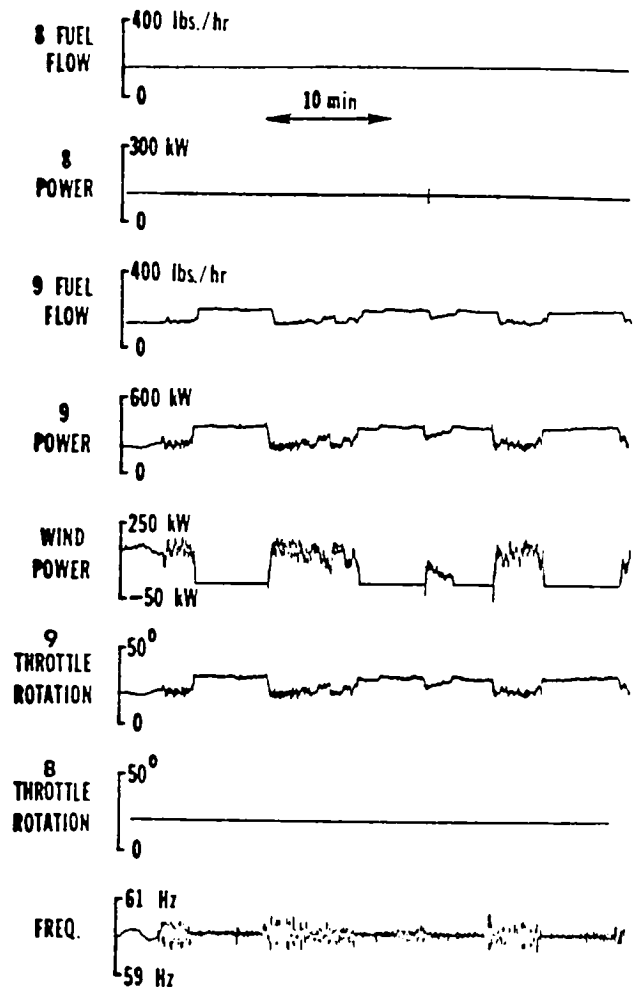

Figure 3 - Sample Strip Chart Record

Diesel Unit Input/Output Characteristics

During the two-month testing period, three diesel units were utilized by BIPCO. Input/output curves were developed for each unit by measuring fuel input for various constant levels of power output while the unit was based loaded. Input/output curves for each unit are given in Figure 4 based on a fifteen minute average of input and output to account for small variations about the set point. The locus of input/output points for each diesel can be described by a straight line with reasonable accuracy. The input/output curves for each diesel were then converted to efficiency curves by dividing output by input over the diesel operating range. Efficiency characteristics for each diesel are given in Figure 5.

Incremental Fuel Consumption

As the wind turbine increases power output, each kilowatt of wind generation replaces a kilowatt of diesel generation. The amount of fuel displaced is determined by the slope of the diesel input/output characteristic having units of lbs. of fuel per hour per kilowatt. The slope of each line shown in Fig. 4 is given in Table 5. This slope, the incremental fuel consumption, was found to be essentially constant for the diesel units under test. The change in diesel output (equal to the change in wind turbine output) multiplied by the incremental fuel consumption yields the displaced fuel.

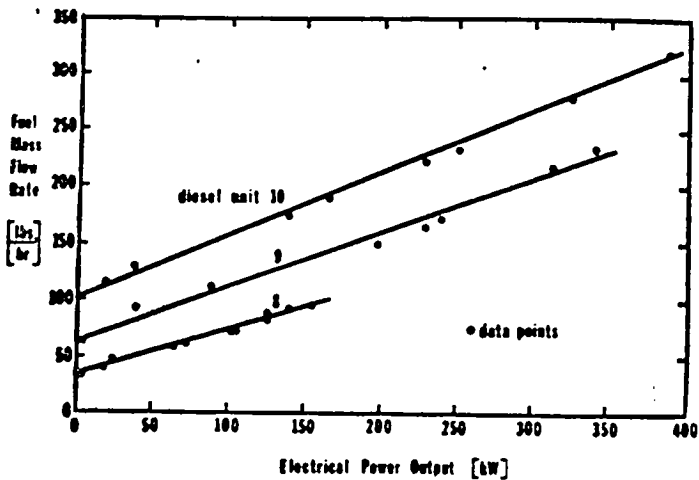

Figure 4 - Diesel Input/Output Characteristic

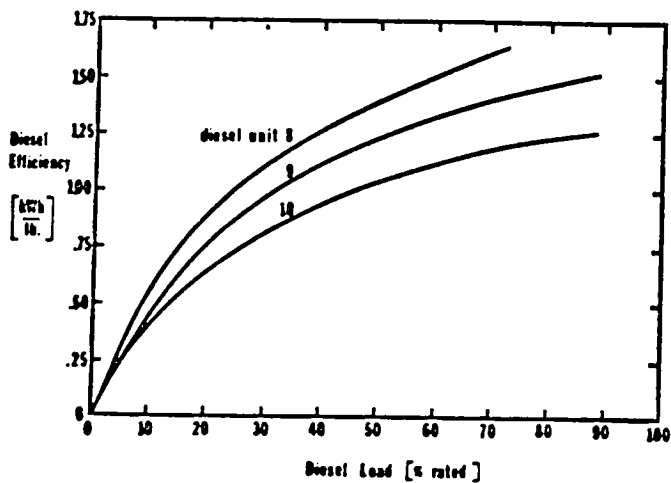

Figure 5 - Diesel Efficiency Curves

Table 5
Diesel Unit Incremental Rates

Unit #	Incremental Rate
8	0.43 lb fuel/kWhr
9	0.49 lb fuel/kWhr
10	0.57 lb fuel/kWhr

This incremental fuel consumption analysis can be related to the overall analysis objective because net wind turbine output (gross less auxiliaries) and the influence of changing diesel efficiency are taken into account. The incremental rate analysis and throttle activity analysis results complete the overall study of wind turbine influence including all four (4) factors.

Diesel Throttle Motion

The diesel unit responsible for load frequency control must continuously adjust power output to maintain electrical frequency. This is necessary because electrical load and wind turbine power output change continuously. The diesel speed governor moves the engine throttle to maintain frequency. In order to examine the effect of throttle motion on engine efficiency, "throttle activity" must be quantified.

Throttle position, in degrees of rotation, was continuously recorded for the diesel unit on load frequency control. BIPCO typically has two diesel units on line with only one of the two regulating frequency. The remaining unit holds constant throttle position. Throttle activity was then quantified by computing total angular travel over a time interval and dividing by the interval of time. Since both directions of travel are taken as positive, the computed parameter becomes average throttle angular speed, thus providing a measure of throttle activity.

Fuel consumption for each diesel was examined as a function of throttle activity. A summary of this analysis is given in Figure 6. Note that only units 9 and 10 are included because unit 8 is always baseloaded with no throttle travel. From Figure 4 the fuel consumption for each diesel under baseload condition is known. This provides a reference to compare fuel consumption under various levels of throttle activity. Fuel consumption under base load conditions was subtracted from the measured consumption at various levels of throttle activity and expressed as a percentage change in consumption. Throttle activity was quantified as average throttle angular speed.

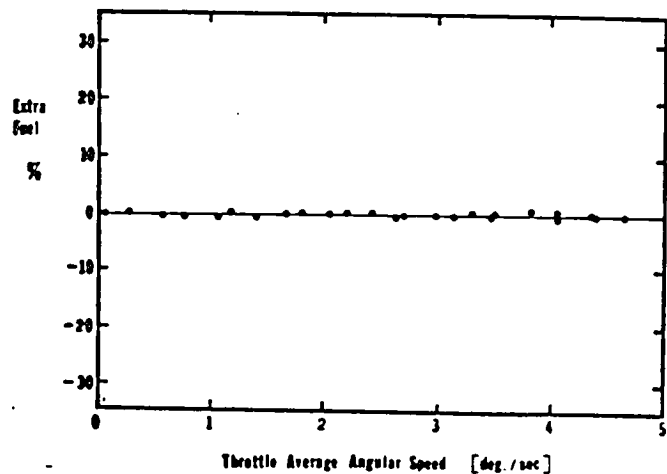

Figure 6 - Throttle Motion vs. Extra Fuel

RESULTS

The results of the fuel consumption analysis are summarized in Figure 7. Two examples are illustrated in Figure 7 corresponding to the unit loads for "low wind" and "high wind" of Table 2. Unit #8 is loaded to a constant 100 kW and unit #9 provides the balance. Fuel consumption reduction is shown for 25 kilowatts and for 150 kilowatts of net wind turbine output. Note that throttle activity has been neglected because it was found to have no significant influence on this result.

When unit #9 is under load frequency control, each kilowatt-hour of net wind generation displaces 0.49 lbs. (0.067 gal.) of fuel. This is equal to the incremental fuel consumption rate for unit #9. When unit #9 is replaced by unit #10, each kilowatt-hour of net wind generation displaces 0.57 lbs. (0.078 gal.) of fuel.

A summary of fuel usage and displacement is given in Table 6. During the test period, unit #9 was used for load frequency control. Therefore, each kilowatt-hour generated by the wind turbine displaced 0.49 lbs. (0.067 gal.) of fuel. Since the wind turbine auxiliaries consume electrical energy, the wind turbine auxiliary energy meter reading is subtracted from gross wind turbine output before total displaced fuel is calculated. During the test period, the MOD-OA wind turbine generated 11% of the system gross electrical energy requirement, based on calculations, and reduced fuel usage by 6.7%.

REFERENCES

1. Robbins, W. H. and Sholes, J. E., "ERDA/NASA 200-kW MOD-OA Wind Turbine Program," 3rd Biennial Conference and Work Shop on Wind Energy Conversion Systems, CONF-770921/1, September 1977.
2. Andersen, T. S., et al., "MOD-OA 200-kW Wind Turbine Generator Design and Analysis Report," Westinghouse Electric Corporation, for NASA Lewis Research under contract DEN3-163, report no. NASA CR 165128, August 1980.
3. Obert, E. F., *Internal Combustion Engines and Air Pollution*, Intext Educational Publishers, New York, N.Y. 1973.
4. Neustadter, H. E. and Spera, D. A. "Applications of the DOE/NASA Wind Turbine Engineering Information System," NASA Lewis Research Center, Cleveland, Ohio, CP-2185, February 1981.

Paul H. Stiller (Member) graduated from Purdue University with a BSME in 1977 and an MSEE in 1978, and from Carnegie-Mellon University with an MSEE (Power Engineering) in 1981. Mr. Stiller is currently enrolled in the University of Pittsburgh, MBA Program.

Mr. Stiller joined Westinghouse Electric Corporation in 1978 and became a Research Projects Engineer in the division of Advanced Systems Technology. In this capacity, Mr. Stiller has been involved in several studies related to utility distribution systems and advanced energy sources. Mr. Stiller has developed techniques to prevent burndown of overhead distribution lines. He has investigated the interconnection of customer-owned photovoltaic generation with the electric utility system, including technical and legal/institutional considerations. Also related to electric utility systems, Mr. Stiller participated in an effort to evaluate the use of superconducting magnetic storage to maintain dynamic stability on the transmission system.

Mr. Stiller is an assistant instructor for the Westinghouse Advanced School in Power Systems, a member of Tau Beta Pi, and a registered Professional Engineer in the Commonwealth of Pennsylvania.

Gary W. Scott (Member) graduated from Iowa State University with a BSEE and a BS in Physics in 1980.

Mr. Scott joined Westinghouse Electric Corporation in 1981 as a Research and Development Engineer of Advanced Systems Technology division. His various projects have included design comparisons of three proposed offshore wind energy conversion systems and a dynamics analysis of capacitor assisted motor-generator sets for feeding large reactive loads.

Mr. Scott is an assistant instructor for the Westinghouse Advanced School in Power Systems.

Richard K. Shaltens graduated from Cuyahoga Community College with an A.A. (Science) in 1973 and Cleveland State University with a B.S.E. (Mechanical) in 1977.

Mr. Shaltens joined NASA Lewis Research Center, Cleveland, Ohio in 1963. He was assigned to the Wind Energy Project Office in July 1977. His major responsibilities have included: Project Engineer for the experimental MOD-OA 2000 kW wind turbine at Clayton, New Mexico, and Deputy Project Manager for the experimental MOD-1 2000 kW wind turbine at Boone, North Carolina.

Mr. Shaltens is currently Project Manager for the four experimental NASA/DOE MOD-OA 200 kW wind turbines. The operational phase of the NASA/DOE MOD-OA project was successfully completed in June 1982 after being synchronized to the grids for 38000 hours and generated in excess of 3600 MWh of electricity.

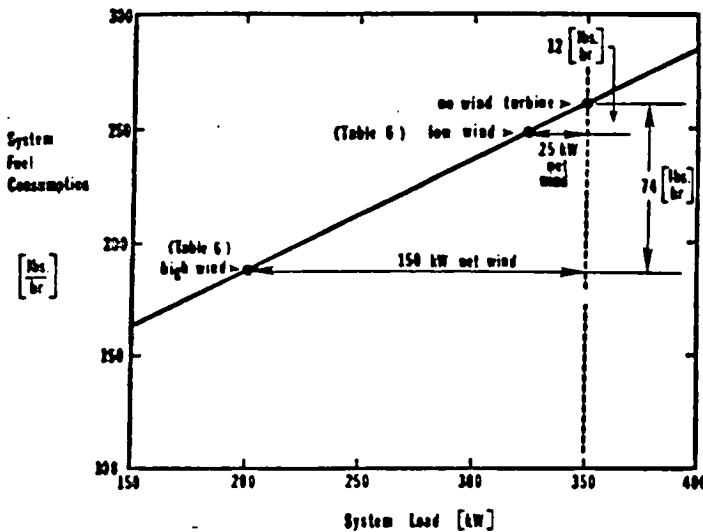

Figure 7 - Fuel Displacement Results

Table 6

Fuel Displacement Results for Test Period*

1)	diesel unit (unit #9) incremental fuel consumption*	0.49 lbs. fuel/kWh
2)	gross MOD-OA wind turbine energy	56,900 kWh
3)	MOD-OA wind turbine auxiliary energy	4,470 kWh
4)	displaced fuel (line 2 - line 3) x line 1	25,700 lbs. (3,560 gal)
5)	gross energy generated (diesel and wind turbine)	496,000 kWh
6)	total fuel burned	358,000 lbs. (49,800 gal)

*Table 6 is based on unit #9 incremental fuel consumption because this unit was used for load frequency control during the test period.

CONCLUSIONS

1. The rate of fuel displacement by the experimental MOD-OA on Block Island is equal to the incremental fuel consumption rate of the diesel unit on load frequency control.
2. Diesel engine throttle activity resulting from wind gusts which change the wind turbine output does not significantly influence fuel consumption.
3. The MOD-OA wind turbine on Block Island, Rhode Island displaced 25,700 lbs. of the diesel fuel during the test period, representing a calculated reduction in fuel consumption of 6.7% while generating 11% of the total electrical energy.

ACKNOWLEDGEMENT

The authors wish to express appreciation to the Block Island Power Company and in particular to Mr. Franklin W. Renz and Mr. Merrill E. Slate, of BIPCO, for their cooperation which made this engineering study possible. This study was sponsored by the NASA Lewis Research Center and funded by the United States Department of Energy under Contract DEN3-275.

Wind Turbine Generator Interaction With Diesel Generators on an Isolated Power System

G. W. Scott
Member IEEE

V. F. Wilreker
Sr. Member IEEE

R. K. Shaltens

Advanced Systems Technology
Westinghouse Electric Corporation
Pittsburgh, PA

NASA Lewis Research Center
Cleveland, OH

Abstract - The Block Island Power Company (BIPCO), on Block Island, Rhode Island, operates an isolated electric power system consisting of diesel generation and an experimental wind turbine. The 150-kW wind turbine, designated MOD-OA by the U.S. Department of Energy is typically operated in parallel with two diesel generators to serve an average winter load of 350 kW. As part of an experimental program to evaluate wind turbine generator performance on the isolated diesel power system, the recordings from an extensive data measurement effort were reviewed and analyzed to define the nature of the dynamic interaction effects. The data were collected over a three-month period on the system to which the DOE/NASA experimental wind turbine was connected. During this time, the diesel units were lightly loaded resulting in up to 60% of the total load demand being supplied by the MOD-OA in periods of severely gusting winds. In three of the modes of normal MOD-OA operation -- startup - synchronization, shutdown/cutout, and continuous fixed pitch running -- power, frequency and voltage transients were comparable with those produced by typical load changes on the diesel system alone. In the fourth mode, variable pitch (constant power) control, a significant reduction in system damping sometimes occurred which gave rise to increased frequency and voltage perturbations under gusty wind conditions. Based on a linear model of the system it is shown that changes in control system settings could be made to improve damping. The main study conclusion is that wind turbine generation, even when providing a large portion of the power required by an isolated utility, can be a practical option resulting in system disturbances no greater than those found in conventional diesel systems.

mental wind turbine was operated until June, 1982, in parallel with existing diesel generation owned by (BIPCO). During this three-year period some 588,000 kWh of wind generated power was produced, and there were over 8,500 hours of successful synchronous operation and approximately 4,300 start-stop cycles. During this period voltage fluctuations were not noticeable to customers.

The purpose of the MOD-OA experimental installation was to obtain early operation and performance data while gaining experience in the operation of a large wind turbine in various utility environments. The BIPCO installation represents the highest wind penetration of all MOD-OA sites with wind generation serving up to 60% of the total system demand.

In a previous paper³, the results of a fuel consumption study were presented for the BIPCO installation with the MOD-OA wind turbine connected in its 150 kW configuration. The present study focuses upon the dynamic interaction investigation for the purpose of quantifying any increased disturbances to BIPCO resulting from connection of the MOD-OA wind turbine generator.

The BIPCO system is detailed in Figure 1 and shows the wind turbine interconnection. Because the tests were conducted during the low power use season (winter), few of the diesel units were connected -- typically only the #8 and #9 units were on line. Such operation represented the conditions where severe transient disturbances and dynamic interactions could be expected.

INTRODUCTION

The Federal Wind Energy Program was established to enable research and development on various applications of wind energy systems. The program was originally administered by the National Science Foundation, and is currently directed and funded by the U. S. Department of Energy. One phase of the program involves the design, fabrication, and experimental operation of large horizontal axis wind turbines. This part of the program is managed by the Lewis Research Center of the National Aeronautics and Space Administration. The first wind turbine generators (WTG) to be placed into utility operation under this program¹ were four 200-kW horizontal axis machines designated MOD-OA. The third MOD-OA machine was installed on Block Island, Rhode Island^{2,5} in mid-1979, and was modified for 150-kW maximum output in October, 1980. The experi-

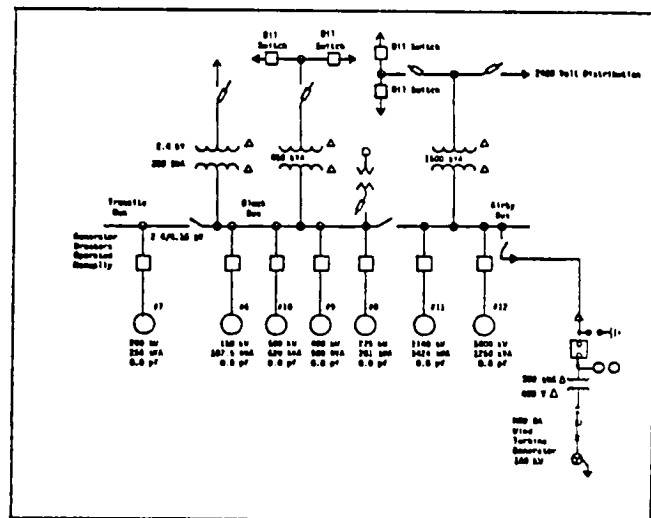

Figure 1 - BIPCO Generation System and DOE/NASA
MOD-OA Wind Turbine Generators (WTG)

83 SM 329-0 A paper recommended and approved
by the IEEE Power Generation Committee of the IEEE
Power Engineering Society for presentation at the
IEEE/PES 1983 Summer Meeting, Los Angeles,
California, July 17-22, 1983. Manuscript submitted
March 21, 1983; made available for printing June 21,
1983.

The instrumentation package used to record some 40 variables versus time and store the results on magnetic tape and strip chart recordings has been described in previous reports^{3,4}. For the purposes of studying dynamic interactions, relatively few of the recorded variables are necessary. The significant response characteristic will be revealed in either the power, frequency or voltage time profiles. Additional variables such as diesel generator throttle position, wind turbine blade pitch angle and nacelle wind speed were also utilized in developing the linear dynamic model used in evaluating system performance.

ANALYSIS

Monitoring the Block Island MOD-OA installation for dynamic interactions took place during the period from February through April, 1982. During this time, a large volume of data were recorded. This analysis consists of reviewing the data to define the nature of interactive behavior and to evaluate the most severe transient disturbances.

There are principally four modes of operation for which it is desired to examine dynamic interaction:

1. Startup and synchronization of the wind turbine generator
2. Normal shutdown and cutout of the wind turbine generator
3. Fixed pitch generation mode
4. Variable pitch (constant power) generation mode

All of these modes of operation are automatically controlled. Startup and synchronization requires the wind speed to be within an acceptable range for a minimum time duration, followed by maintenance of a phase match between the MOD-OA generator voltage and system voltage for a certain minimum time duration after which the breakers are closed. The blade pitch control then ramps the power at a fixed rate until fixed pitch conditions occur or until the desired power setpoint is reached⁵. Voltage and power transients can be quite significant if out-of-phase synchronization were to occur.

For the second operational mode, a normal shutdown is initiated when the wind speed is either too low or too high. The blade pitch angle is decreased until the wind power output is close to zero at which time the breaker opens. If the current flowing at this time is sizable, the voltage transients can be significant.

In the third mode of operation, the blades are fixed at zero degrees, which optimizes wind power transfer but results in the power output varying with the wind speed squared. The power setpoint on the Block Island MOD-OA is manually adjustable from zero to 150 kW. The purpose of the adjustable setpoint was to allow BIPCO utility personnel to lower than maximum settings of the MOD-OA to prevent the controlling diesel from dropping to less than 50% rated. Operation of the diesels for extended periods at low power levels could result in possible engine damage and/or excess oil accumulation in the exhaust stack. Fixed pitch operation occurs when the wind supplies less power than demanded by the power setpoint. The nature of the dynamic behavior in this mode is dominated by the diesel speed governor controller.

The fourth mode, variable pitch (constant power) operation, has the potential for producing the highest levels of interaction because of the presence of both diesel and wind turbine control loops. When wind power rises above the power (usually 150 kW) setpoint, the pitch control system begins operation to maintain an average power equal to the setpoint. The pitch control system consists of a power measurement transducer, a manual power setpoint control, a proportional-plus-integral feedback function, and a hydraulic actuator which varies the pitch of the blades.

To serve as a basis for comparison, the Block Island system operating with diesel generation alone is first examined.

Characteristic BIPCO Diesel Dynamics (Without MOD-OA WTG)

Figure 2 shows the power output from two diesel units (#8 and #9) and the system frequency. Unit #8 was set at fixed throttle while the governor of Unit #9 was operational. At a time of approximately 315 seconds, a load increase occurred causing the speed of both diesels--and hence system frequency -- to decrease. Then the governor on Unit #9 responded to maintain system frequency constant by increasing the power. This resulted in a 15 kW power and 0.4 Hz frequency peak-to-peak change. An apparent overshoot of some 20% could be interpreted to be the system characteristic damping; however, random load fluctuations made it difficult to accurately measure the actual value. This is more easily seen in Figure 3 where the load activity makes the system frequency (and thus governor control loop) appear to be in a condition of sustained oscillation. This does not imply a condition of marginal system instability; rather, the frequency of about 1 rad/s that dominates in Figure 3 is a characteristic of the BIPCO diesel system.

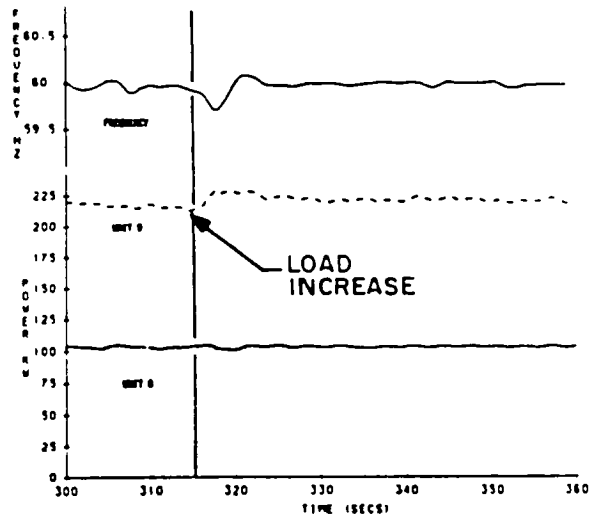

Figure 2 - Response to a Single Load Application on BIPCO Diesel System (without MOD-OA WTG)

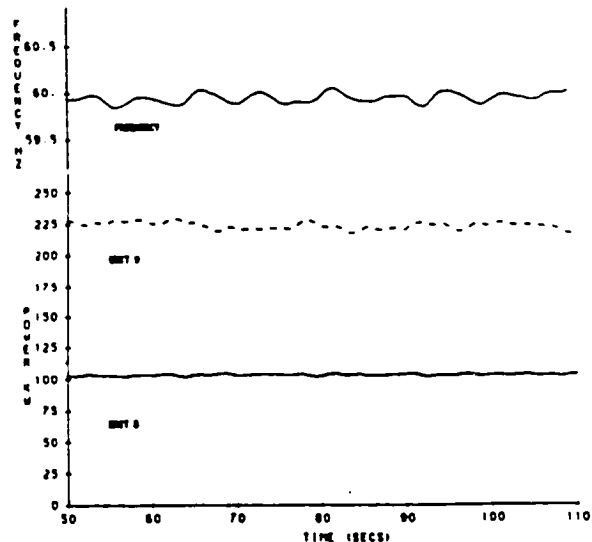

Figure 3 - Normal Load Fluctuation on BIPCO Diesel System (without MOD-OA WTG)

Normal Startup and Shutdown Mode Behavior

A typical response following MOD-0A wind turbine generator synchronization is shown in Figure 4. The Unit #10 diesel is under governor control, so that as blade pitch angle is ramped up providing wind power contribution, the governor action results in a near "mirror image" power profile to meet the load demand. The power response shows a distinct oscillatory mode of about 6.6 rad/s, beginning shortly after synchronization at about the 162 second point. Also, after ramping to fixed pitch operation at 175 seconds, a damped oscillation of 0.8 rad/s occurs having a peak-to-peak power swing of about 15 kW. The frequency variation is some 0.6 Hz peak-to-peak, and the average voltage at the MOD-0A bus rises to 1.4%. The 0.8 Hz frequency is largely dependent on the governor dynamics, while the 6.6 rad/s frequency is the result of the wind on the blade being blocked by the tower--called the tower shadow effect.⁵ This effect does not seem to increase the normal 1% peak-to-peak voltage, nor is it visible in the system frequency.

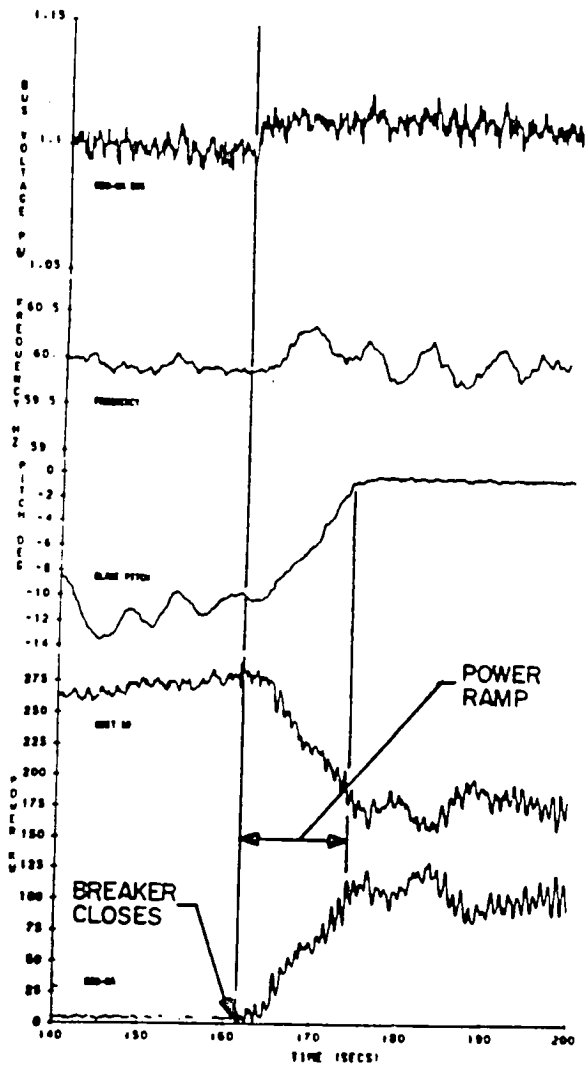

Figure 4 - Startup and Synchronization of the MOD-0A WTG

The typical shutdown case is shown in Figure 5. In this case, the damped power oscillation that occurs is somewhat lower in frequency and higher in amplitude compared to that produced during synchronizing. No abrupt transient is observed in power or voltage during the generator disconnection. The governor controlled #10 diesel power is observed to have successfully responded to the rapidly decreasing (5 to 10 kW/sec) MOD-0A power prior to generator disconnection.

In both startup and shutdown, the effect of the MOD-0A connection or disconnection in BIPCO system is of about the same magnitude as that produced by normal load fluctuations.

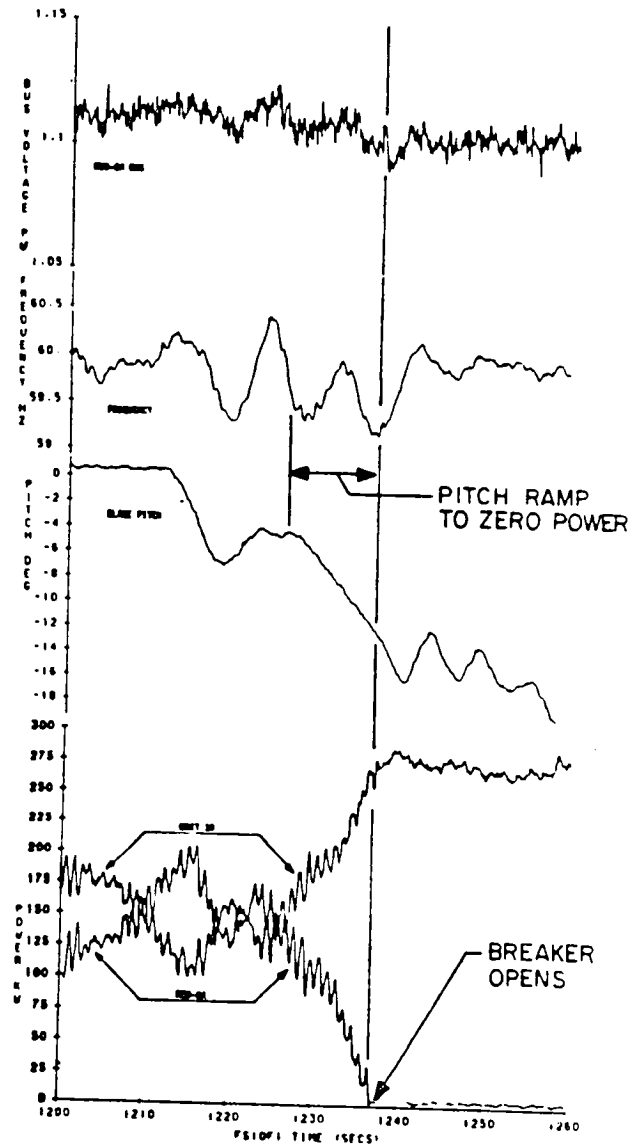

Figure 5 - Normal Shutdown and Cutout of the MOD-0A WTG

Fixed Pitch Versus Variable Pitch (Constant Power) Behavior

An example of comparative performance between fixed, and variable pitch (constant power) control appears in Figure 6. Between 60 and 70 seconds the wind speed is dropping, causing the wind turbine to fall below the 150-kW setpoint. The blade pitch controller in turn changes the blade pitch angle until it reaches its maximum position. This holds out to the 95-second point at which time the increased wind speed causes the power output to rise above the 150-kW setpoint and the blade pitch

angle changes to reduce output power. At about 110 seconds an oscillation of about 0.9 rad/s develops and persists for several cycles until decreased wind speed again results in fixed pitch operation--at which point the oscillation damps out. The 0.9 rad/s oscillation is readily apparent in the system frequency, resulting in a peak-to-peak variation of about 0.7 Hz. During the fixed pitch intervals, the peak-to-peak system frequency variations do not exceed 0.4 Hz. Figure 6 also demonstrates that the bandwidth of the pitch control loop is much lower than the tower shadow frequency of 6.6 rad/s in that the pitch control output has a negligible amplitude at this frequency.

These variations were among the most severe encountered and do not characterize all fixed-variable intermittent pitch intervals, since the behavior will vary considerably with wind gusting conditions. However, even intervals where the oscillatory amplitudes are lower, they tend to oscillate at about the same dominant frequency, i.e. around 0.9 rad/s. This observation suggests that the oscillatory behavior is significantly related to the pitch controller dynamics.

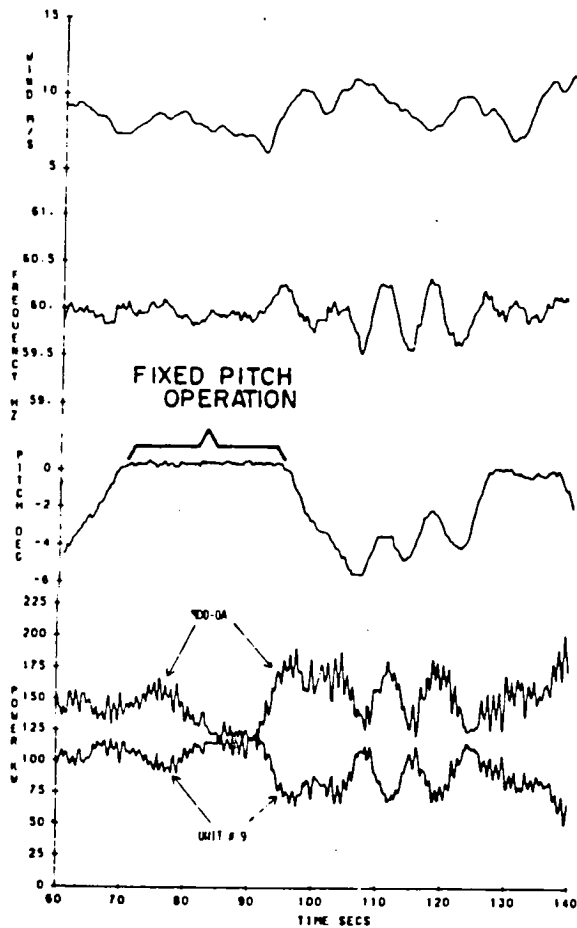

Figure 6 - Fixed Pitch and Variable Pitch (Constant Power) Variation of the MOD-OA WTG

Linear Model-Optimization

Toward the conclusion of the field measurement program, a linear model was formulated specifically for the purpose of identifying and quantifying the 0.9 rad/s underdamped oscillation which was primarily observed during variable pitch operation. This objective was met by retaining the pertinent controller dynamics for both the diesel unit

governors and WTG pitch controller/actuator and lumping the inertia of the diesels (#8 and #9) and assuming a single total inertia for the MOD-OA. The conceptual model that results is shown in Figure 7.

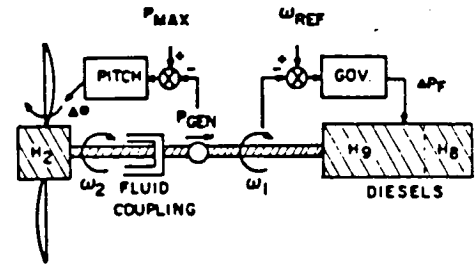
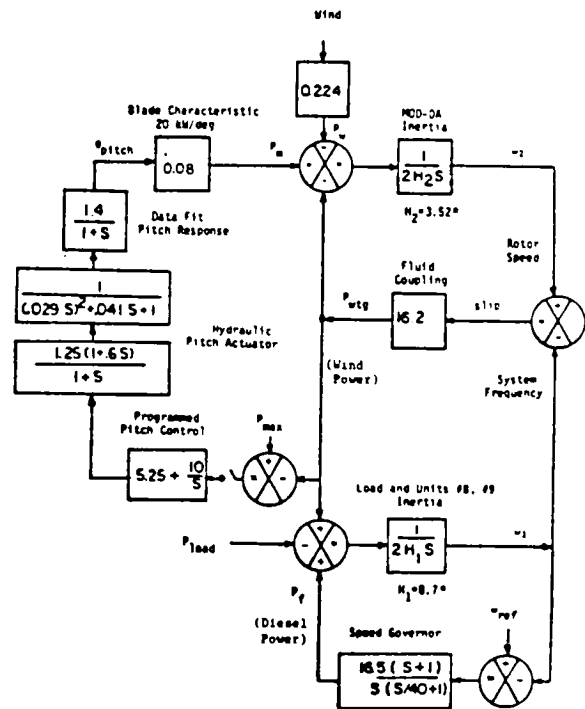

Figure 7 - Conceptual Model of Diesel and WTG System

The fluid coupling shown in Figure 7 transfers speed difference between the MOD-OA and the synchronized wind turbine alternator into power. The actual function is non-linear (square law), but for the model it is linearized, resulting in a constant for the particular power setpoint selected. Figure 8 shows the functional block diagram that is obtained.

Shown in Figure 8 are the control transfer functions applicable to MOD-OA on Block Island. Appearing in a block labelled "data fit pitch response" is a simple lag that was required to match the phase/gain characteristic of the model with that measured from the data. It is applicable only in the region of 0.9 rad/s.



* - Inertia Constants on 250-kVA Base

Figure 8 - MOD-OA and BIPCO Dynamic Model

The modelled time response of the MOD-OA to a step change of 100 kW of wind power is shown in Figure 9. Under fixed pitch control on the BIPCO system, the power output has a rise time of 2 seconds and 6% overshoot. The rise time characteristic is affected mostly by the ratio of fluid coupling damping to MTG inertia. The higher the ratio, the faster the response. The overshoot is determined by the system frequency fluctuation resulting from the direct response to the load decrease.

Activation of the pitch control results in an underdamped response with an exponential time constant of 10 seconds (95% settling time of 30 sec.). Although this is a stable response, the low damping allows the oscillation to continue for several cycles before damping out.

If the MOD-OA is connected to a much larger system (an "infinite" bus), the activation of pitch control results in a slightly underdamped response with a time constant of just 3 seconds. Thus, the response of the BIPCO diesels contribute significantly to the 0.9 rad/sec oscillation recorded in the data.

The response of the MOD-OA with pitch control shows considerable improvement by modifying the proportional and integral control gain function from $5.25 + 10/s$ to $40 + 4/s$.

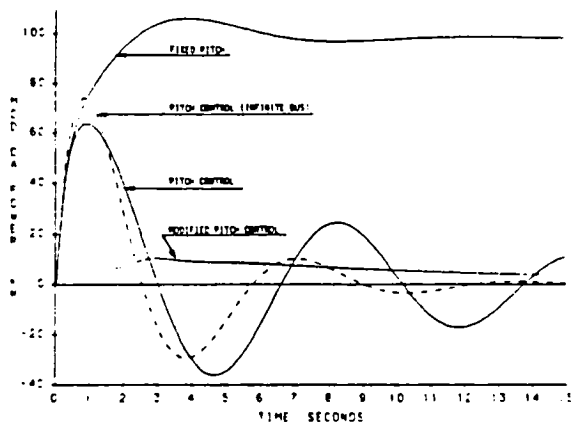

Figure 9 - Dynamic Model Response to 100 kW Wind Step Change

Because the optimized proportional-integral gains obtained for the model were not tested on the actual system, the improvement predicted cannot be guaranteed. However, even a partial increase in the damping would probably reduce the system frequency deviations to within the range obtained with diesel operation alone.

CONCLUSIONS

Power and voltage transient due to MOD-OA normal startup and shutdown were of insignificant magnitude as were the cyclic power variations due to the tower-shadow effect.

Power fluctuations due to MOD-OA operation under fixed-pitch operation were successfully compensated for by the action of the diesel governor control. As a result, the frequency variations were approximately the same magnitude as those caused by the major load demand fluctuations during diesel operation alone.

MOD-OA operation under variable (constant-power) pitch control resulted in an increase in the amplitude of the underdamped system natural frequency (0.9 rad/s). The accompanying frequency variation reached 1% under the most severe conditions for a 150-kW MOD-OA

power setpoint. However, linear model analysis suggests that by adjusting the diesel governor and/or blade pitch controller additional damping can be obtained to produce the same performance given by fixed pitch operation.

Wind turbine generation, even when providing a large portion of the power required by an isolated utility can be a practical option resulting in system disturbances no greater than those found in conventional diesel systems.

ACKNOWLEDGMENT

The authors wish to express appreciation to the Block Island Power Company and in particular to Mr. Franklin W. Renz and Mr. Merrill E. Slate, for their cooperation which made this engineering study possible. This study was sponsored by the NASA Lewis Research Center and funded by the United States Department of Energy under Contract DEN3-275.

REFERENCES

1. Robbins, W. H. and Sholes, J. E., "ERDA/NASA 200-kw MOD-OA Wind Turbine Program," 3rd Biennial Conference and Work Shop on Wind Energy Conversion Systems, CONF-770921/1, September, 1977.
2. Andersen, T. S., et al., "MOD-OA 200-kw Wind Turbine Generator Design and Analysis Report," Westinghouse Electric Corporation, for NASA Lewis Research under contract DEN3-163, report no. NASA CR 165128, August, 1980.
3. Stiller, P. H., Scott, G. W., Shaltens, R. K., "Measured Effect of Wind Generation on the Fuel Consumption of an Isolated Diesel Power System," presented at the 1983 IEEE Winter Power Meeting.
4. H. E. Neustadter, and D. A. Spera, "Applications of the DCE/NASA Wind Turbine Engineering Information System," NASA Lewis Research Center, Cleveland, Ohio, CP-2185, February, 1981.
5. A. G. Birchenough, et. al., "Operating Experience with Four 200 kW MOD-OA Wind Turbine Generators," Proceedings of the Large Horizontal Axis Wind Turbines Workshop, Cleveland, Ohio, July 28-30, 1981.

MEASURED EFFECTS OF WIND TURBINE REACTIVE POWER CONTROL ON AN ISOLATED UTILITY

R. F. Smith V. F. Wilreker
Sr. Member IEEE Sr. Member IEEE
Advanced Systems Technology
Westinghouse Electric Corp.
Pittsburgh, PA

R. K. Shaltens

NASA Lewis Research Center
Cleveland, OH

Abstract

One phase of an overall effort in evaluating performance of a 150 kW MOD-OA wind turbine connected to the Block Island Power Company (BIPCO) system consisted in analyzing three methods of excitation (reactive power) control. These are identified as: 1) constant var (reactive), 2) constant voltage, and 3) constant power factor (PF) control. The power system environment in which the wind turbine generator (WTG) exists ultimately determines which method of control is the most suitable. In the case of the BIPCO installation, the major emphasis was to insure sufficient WTG electrical torque during wind gusts in low power output periods. Subsequent use of constant PF control demonstrated an adequacy of performance equivalent to that of constant var control while constant voltage control indicated a diminished capacity to maintain synchronism with the utility, when compared to constant var or PF control. A mathematical model which incorporates the detailed excitation system transfer functions is used to compare the results indicated by the measurements produced during a three-month data acquisition effort.

INTRODUCTION

The Wind Energy Project is a part of the Federal Energy Program originally administered by the National Science Foundation and is currently directed and funded by the U.S. Department of Energy. One phase of the program involves the design, fabrication, and experimental operation of large horizontal axis wind turbines. This part of the program is managed by the Lewis Research Center of the National Aeronautics and Space Administration. The first wind turbine generators (WTG) to be placed into utility operation were four 200-kW horizontal axis machines designated MOD-OA. The third MOD-OA machine was installed on Block Island, Rhode Island, in mid-1979, and was modified for 150-kW maximum output in October, 1980. The experimental wind turbine was operated until June, 1982, in parallel with existing diesel generation owned by BIPCO. During this three-year period some 588,000 kWh of wind generated power was produced, and there were over 8,500 hours of successful synchronous operation.

84 WM 056-8 A paper recommended and approved by the IEEE Power Generation Committee of the IEEE Power Engineering Society for presentation at the IEEE/PES 1984 Winter Meeting, Dallas, Texas, January 29 - February 3, 1984. Manuscript submitted June 1, 1983; made available for printing January 6, 1984.

An intensive data gathering effort was conducted in 1982 from February through April on the BIPCO system. During this period, system loading was low, so that the 150 kW level of the MOD-OA WTG represented a wind turbine power penetration of up to 60% of the total load demand. The some 40 variables continuously recorded versus time enabled three distinct analysis efforts to be conducted. The first of these focused on the fuel displacement afforded by the WTG operation⁽¹⁾ and the second on the interactive dynamic behavior between the diesel system and MOD-OA WTG⁽²⁾. This report addresses the effect on performance of three types of WTG field excitation control. These are identified as:

- (1) Constant var (reactive power) control
- (2) Constant power factor control
- (3) Constant voltage control

Each of these modes of reactive power control were manually selectable on the Block Island MOD-OA WTG. For most specific WTG sites, it is most probable that once a control strategy is chosen, it would not be changed. However, having all three available provided a laboratory-like facility for assessing the advantages and disadvantages of each method as it applied to this particular site.

ANALYSIS

For the BIPCO system operating with diesel generation alone, normally only one diesel generator unit is operating in the controlled constant voltage mode -- the others are switched to manual (unregulated) resulting in a constant voltage to be applied to the generator field. In this manual mode, system reactive load requirements can be flexibly met at the option of the system operator. No changes in this basic operating procedure were made by the utility when the MOD-OA wind turbine generator was connected into the grid. To provide some perspective in the usage among the three methods of reactive power control, the following is a discussion of the application to the MOD-OA WTG installed on the BIPCO system and also to utility systems in general.

Constant VAR Control

Prior to, and during the first month (February, 1982) of the data acquisition period, the excitation control on the WTG was maintained in the constant var mode. This choice was based mainly on the fact that WTG synchronization is best maintained by having as high a field excitation as possible. Also, the fact that the impedance between the WTG and the diesel generation buses was small avoided the concern of over or under voltage being a problem at the WTG terminals.

This control method can assume one of several schemes in accomplishing its stated objective. For example, by removing the terminal voltage feedback signal to the regulator and replacing it with a signal proportional to the reactive power, the latter may be controlled statically or dynamically. Another technique -- the one actually used -- consists of inserting a voltage in series with the voltage reference. Here, the terminal voltage feedback signal is unaltered and an integral reset control changes the reference until the actual reactive power exactly matches the desired setting in steady-state.

The second technique has the advantage of tending to preserve the same transient response as provided by the constant voltage control option. A possible disadvantage is that the capability of achieving supplemental damping of the system natural electrical frequency may be limited by the dominance of the voltage feedback loop. In the case of the generator used, the damping provided is relatively large, so that additional damping from the exciter is not a necessity.

Constant Power Factor Control

The constant PF control scheme for excitation control was switched in for evaluation in March of 1982. For a nominal system with non-excessive var requirement (i.e., the lagging power factor load is relatively low), maintaining constant power factor WTG operation would be the most desirable method of excitation control from the standpoint of the effect the WTG generation has on the diesel system. That is, under constant power factor, the WTG appears to the diesel generator as a (negative) fixed impedance load -- as such, this probably imposes the least severe loading constraints since ideally all generating units would be operating at their design power factors.

The method of control of power factor utilizes the same reset function used for var control. The difference is that rather than comparing with a constant reference, the reference is now proportional to the real power. Thus, the ratio of vars to power and hence power factor is maintained constant.

Constant Voltage Control

The method of constant voltage control was found to be the least desirable of the three methods for the BIPCO WTG and was evaluated only over a six-hour period in May, 1982. Those systems where constant voltage control does find application occurs when the generating units (wind, diesel, or other) are separated from one another by relatively long transmission lines, resulting in terminal voltages which are nearly directly proportional to the level of field excitation. Consequently, to avoid voltage excursions that could be damaging, the field excitation must be controlled by voltage, or at least by having terminal voltage determine the limits of excitation.

A problem with constant voltage control on any type of interconnected synchronous generators (WTG or diesel) is the relative inability to share proportionately the reactive power load. The situation is analogous to real power sharing unbalances that can occur when the speed governors on generators are at a low droop setting -- i.e. a low ratio of speed change to load change. By increasing the speed droop, real power load sharing can be improved. So it is with reactive load. This is achieved by introducing an additional feedback signal to the voltage regulator which is proportional to terminal current and lagging terminal voltage by 90° . In effect, this acts as an inductive reactance placed in series with the generator, but lying outside the voltage regulator loop, so that reactive current is limited. This so-called reactive droop compensation has increasing importance as the impedance of the tie among generators decreases.

The dynamics of the voltage control loop -- formed by regulator/exciter and generator can also affect the system stability in terms of changing the damping of the system natural frequencies. It is

found in general that, relative to fixed excitation (no voltage control), the faster the voltage regulator responds, the lower will be the damping of the system natural frequency. It is also possible to produce negative damping from some regulator/exciter designs that interact with the system's natural frequency.

Data Measurement Results

Figure 1 is a block/single line diagram that functionally describes the typical BIPCO system configuration during the three-month data instrumentation and collection period with emphasis on the WTG excitation components. The MOD-0A wind turbine generator is a salient pole type whose field is driven by a brushless rotating exciter; the stationary field winding of the latter is in turn powered by a solid-state regulator which includes an adjustable damping feedback circuit. An additional module incorporates the selectable var or PF control action.

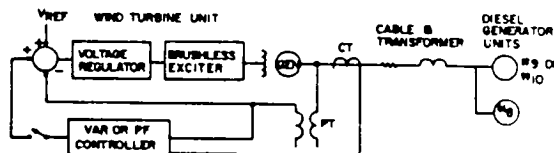

Figure 1 - Basic Configuration for Study of Excitation Control on MOD-0A WTG.

The diesel generator complement shown was typically comprised of only two units: one running under both voltage regulation and governor control and the other under fixed excitation and fixed throttle. The excitation units on the diesels are characterized by terminal voltage recovery times in the 1 to 2 second range and for the governor control between 3 and 5 seconds.

As previously reported⁽²⁾, the BIPCO system exhibits damped oscillations in the .8 to 1 rad/s range with or without the MOD-0A WTG. When the MOD-0A is connected and in the variable blade pitch (constant power) mode, the magnitude of the system frequency fluctuations can rise above those encountered with diesel operation alone. These oscillations are not confined to the real power component alone -- they also appear on the reactive power related variables. Figure 2 is typical of the performance in the variable pitch/constant power and constant var control modes. All of the variables have been filtered over a 1 second interval to more easily interrelate them.

Figure 2 reveals how well the WTG MOD-0A reactive power is controlled to the 50 kvar setpoint. Also, it is apparent that the controlled diesel (Unit #9) supplies the var fluctuations resulting from terminal voltage variations. Another aspect of reactive power behavior is that the fixed excitation diesel generator (Unit #8) exhibits var fluctuations 180° out of phase with those of Unit #9; so that although Unit #8 is supplying a fixed level of vars to the system, it is absorbing a portion of the variational contribution from Unit #9. In effect then, the larger the number of generators with fixed excitation, the greater the burden on the controlled unit from a transient or variational standpoint. As shown in Figure 2, generators under constant var control have the advantage of not affecting this fluctuating var component.

Figure 3 is typical of the behavior when the WTG excitation control is in the constant power factor mode. For this particular case, the MOD-0A is operating below the nominal 150 kW setpoint so the blade pitch is fixed. The wind profile during the 60 second segment produces WTG power fluctuations of the same magnitude (i.e., 30-40 kW) as in Figure 2. However, the reactive power variations are noticeably higher than in that case. Also, because Unit #10 is the only diesel generator

connected, the variational var component due to a fixed excited generator is missing, and there is a corresponding reduction in the peak-to-peak var amplitude of Unit #10. If the ratio of WTG power to vars is calculated, it is found to have the same relative constancy as vars did in Figure 2, denoting good control of power factor. Similar to Figure 2, the power and var fluctuations are in-phase and the peak-to-peak frequency variations are nearly the same.

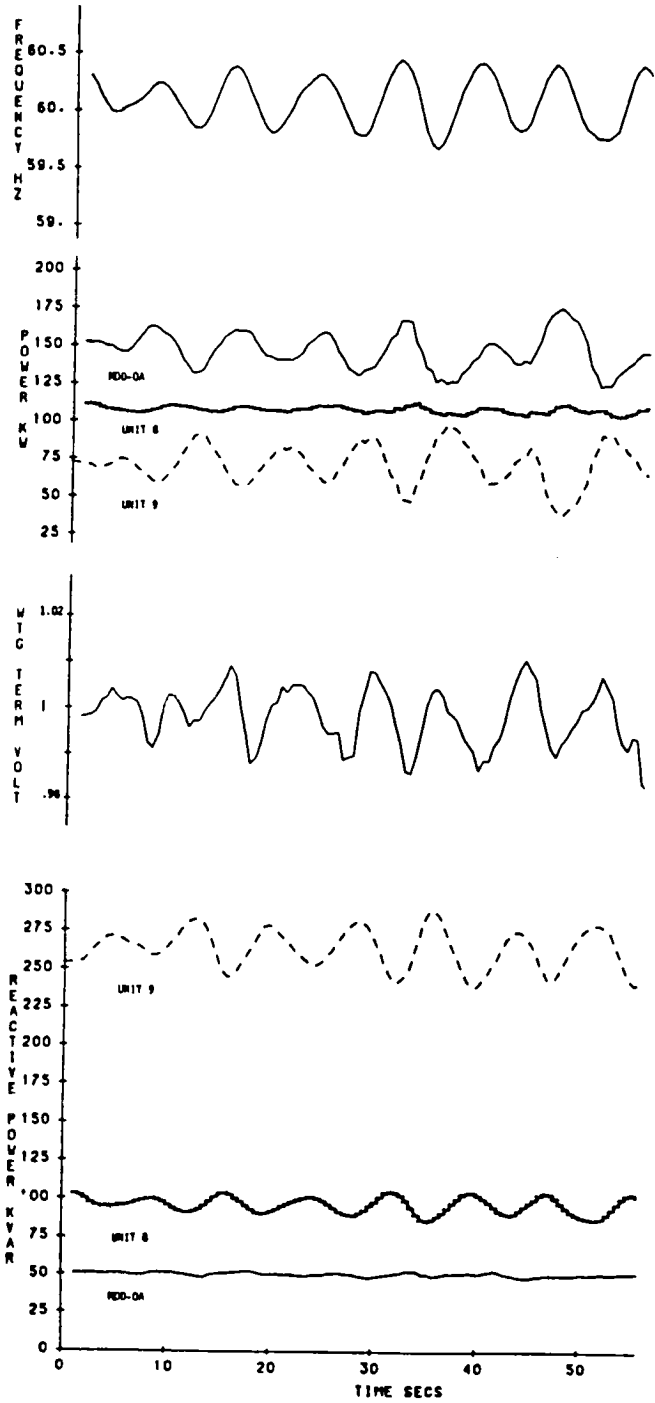

Figure 2 - Measured Performance with MOD-OA WTG under Constant Reactive (var) Control

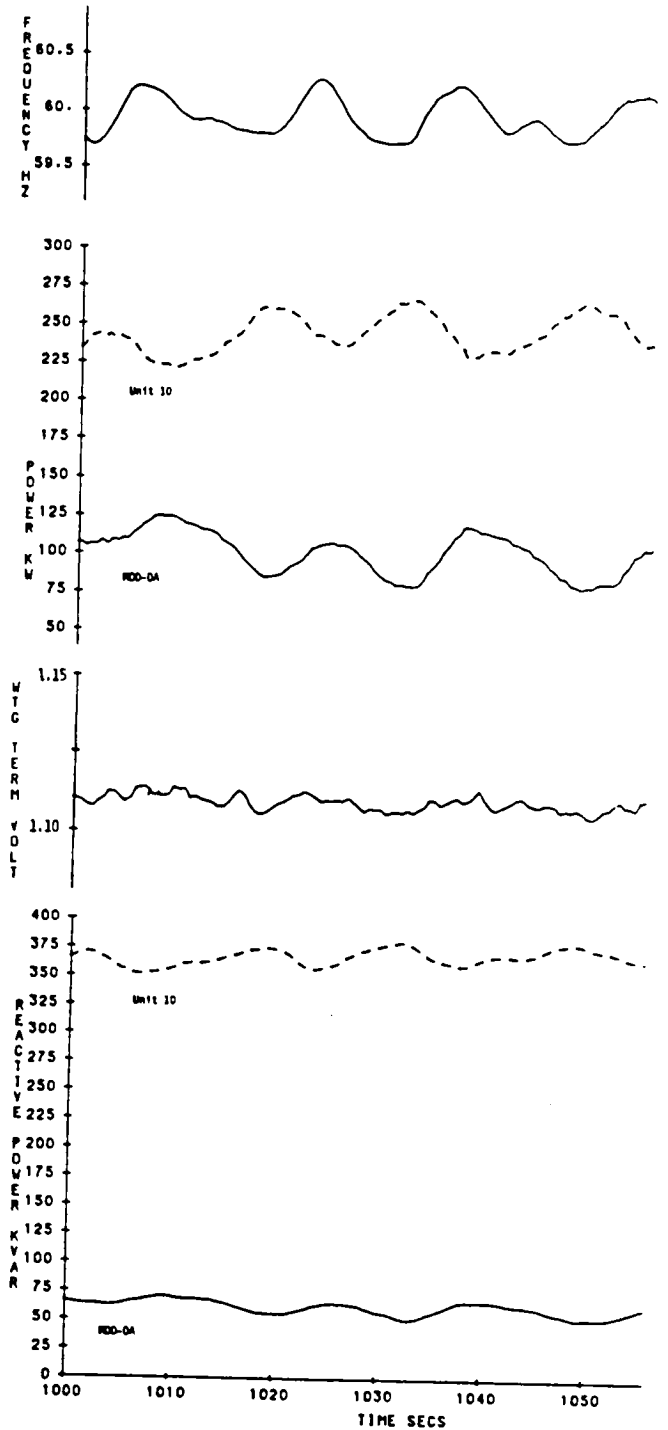

Figure 3 - Measured Performance with MOD-OA WTG under Constant Power Factor (PF) Control

Figure 4 shows behavior under constant voltage control with 5% reactive current droop compensation. Here, the wind activity has minimal gusting activity with the result that the dominant .9 rad/s oscillation is low. As a result, the var activity of the diesel generator is relatively low. Contrasted with the other two schemes, the

WTG var fluctuations are seen in Figure 4 to be higher than those of the diesel generator. Also, the low frequency var and power oscillations are opposite in phase -- the major result of which is that the transient excitation requirements of the diesel unit are minimized.

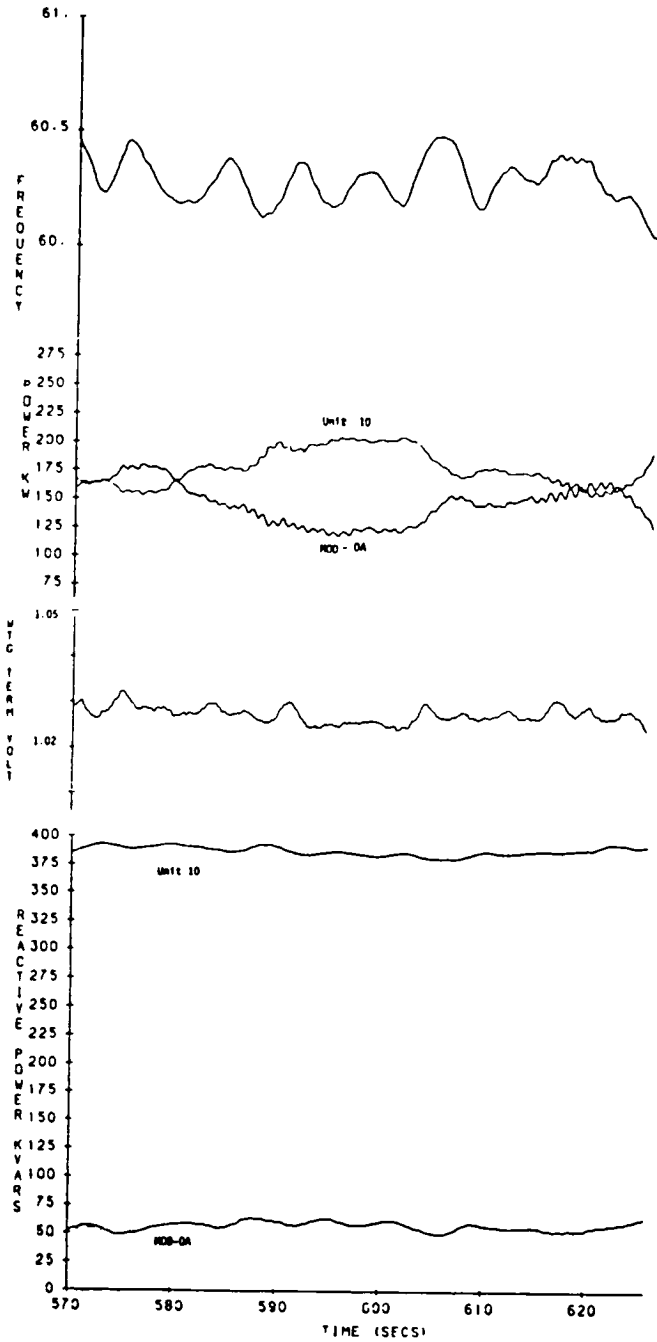

Figure 4 - Measured Performance with MOD-OA WTG under Constant Voltage Control - 5% Droop Compensation

Figure 5 serves to demonstrate how the characteristics of constant voltage control can ultimately lead to a deterioration in performance. Here the droop compensation has been set to zero and as the wind speed rises producing WTG power above the 150 kW setpoint, the blade pitch control begins to reduce the power. As the combination of WTG dynamics and wind profile interact to produce a growing oscillation, the phase

opposition between power and vars (at 0.7 rad/s) becomes evident. This is just the opposite desired condition from the standpoint of preventing loss of synchronism. Although the fluid coupling used in the WTG minimizes this problem, Figure 5 shows the potential for underexcited operation as the power swings become large. Therefore, uncompensated constant voltage control should probably be avoided.

Figure 5 also shows a shutdown operation -- increasing blade pitch gradually to bring the WTG power to zero. Now, because of the constant voltage control, the WTG excitation and vars are increasing, so that at the time when the line breaker opens, the WTG is delivering around 150 kvars. Dropping this generation appears to the diesel system to be equivalent to applying a 150 kvar inductive reactive load as evidenced by the drop in terminal voltage seen in Figure 5. The recovery of the voltage also illustrates the response of the diesel generator regulator/exciter control system.

The traces comprising Figure 5 are unfiltered and show the presence of the approximate 6 rad/s wind shadow⁽²⁾ frequency in the WTG power. The WTG vars trace evidences the 6 rad/s frequency, but at an amplitude less than 30% of that visible on the power trace.

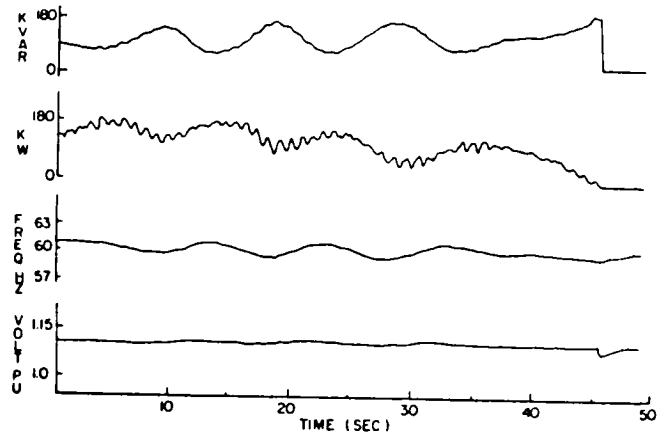

Figure 5 - Measured Performance with MOD-OA WTG under Constant Voltage Control - 0% Droop Compensation - Manually Initiated Shutdown of WTG

Simulation Model Results

In examining the foregoing field measurement results, it is difficult to compare and quantify the effect on system voltage and frequency as a function of the type of excitation system alone. A transient (time domain) model of the system block diagram given in Figure 1 was therefore formulated and digitally programmed using constants developed by the equipment manufacturers and given in operational form on Figure 6. The electrical dynamics were represented in detail using the well-known Park transformation equations. The diesel generators were lumped together and represented by a fixed voltage in series with their equivalent transient reactance. This simplified model for the diesel generators was justified primarily on the basis that no evidence of interaction due to the diesel generator excitation system was observed in the data.

For the mechanical portion of the simulation model, it was found convenient to use the model developed in a previous paper.⁽²⁾ Figure 7 shows how that model has been modified: Here, torque quantities rather than power quantities are used and, rather than assuming power and/or torque on the output side of the fluid coupling to

be identical to WTG electrical power and/or torque, the latter is now a function of the electrical dynamics of the WTG. Also, the previous model lumped the moments of inertias of the blades, hub, gears, pulleys, and input side of the fluid coupling into a single value. Detailed mechanical modal analysis⁽³⁾ gives a low, purely mechanical, modal frequency of approximately 20 rad/s for MOD-DA systems. Because the WTG ratio and output fluid coupling inertias are small, the modal frequency formed by these and the equivalent air gap torque spring constant is also in the 20 rad/s region. It, therefore, was deemed advisable to include the mechanical mode to determine if any interaction might occur between these two nearly equal modal frequencies. Two approximately equal inertia constants (H_a , H_b) and a single spring shaft constant K form this simplified blade/hub dynamics portion.

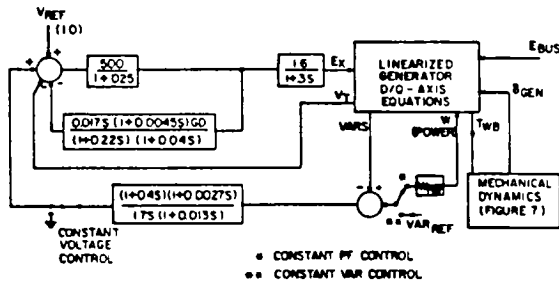

Figure 6 - Simulation Model for Excitation Systems Evaluation

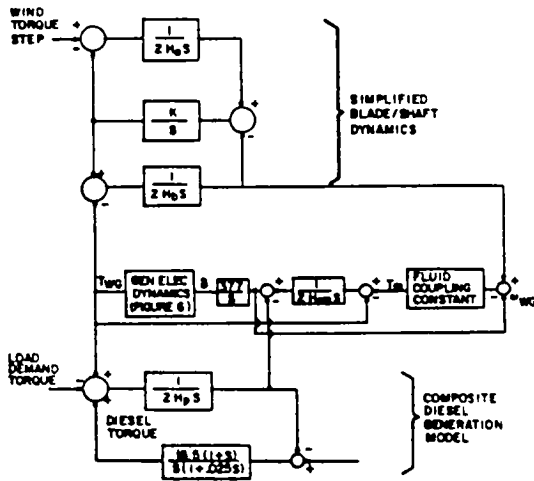

Figure 7 - Mechanical Portion of Model

Not appearing in the model of Figure 7 is the blade pitch control and wind dynamics representation. As pointed out in the previous paper,⁽²⁾ this semi-empirical model was designed to represent only the frequency region around .9 rad/s, and might not be appropriate for behavior over a broader frequency band.

With the model now formulated, the two most significant variables for evaluating system performance are the responses of system voltage and frequency to a step torque equivalent to a rapid increase of wind speed at the turbine blades. Variations of the system frequency (nominal 60 Hz) reflect the dynamic characteristics of both WTG and the diesel generators, and, therefore, it is difficult to assess the relatively minor effect of the WTG excitation system by viewing only the variations in system frequency. A more sensitive measurement is provided by comparing the electrical angle between WTG rotor and diesel interval voltage. The smaller the excursion of this angle, the smaller will be the frequency fluctuations, in general.

Figure 8 shows the response of the electrical angle for four excitation configurations. The peak system angle excursion due to the .5 p.u. wind torque step varies between 0.6 rad for constant PF control to 0.78 rad for constant voltage control at zero droop. By the above criterion then, the PF control is the most effective in minimizing frequency deviation while voltage control with no droop compensation is the least effective. Conversely, as also shown in Figure 8, the voltage regulation is the poorest under PF control and the best under voltage (0% droop) control. However, voltage regulation at the effective system bus will be determined by the voltage regulator on the diesel unit, so from the standpoint of steady-state voltage regulation (i.e., 2 or more seconds following the wind torque transient) at the system bus, WTG voltage regulation is of lesser importance. A characteristic of the var and PF control is that they provide a better damped response by setting the regulator damping gain (GD) to a lower setting. The degree of this improvement is compared in Figure 9. In purely voltage control there is little difference between a damping setting of 1. or .4 so that one setting is feasible for all three control modes.

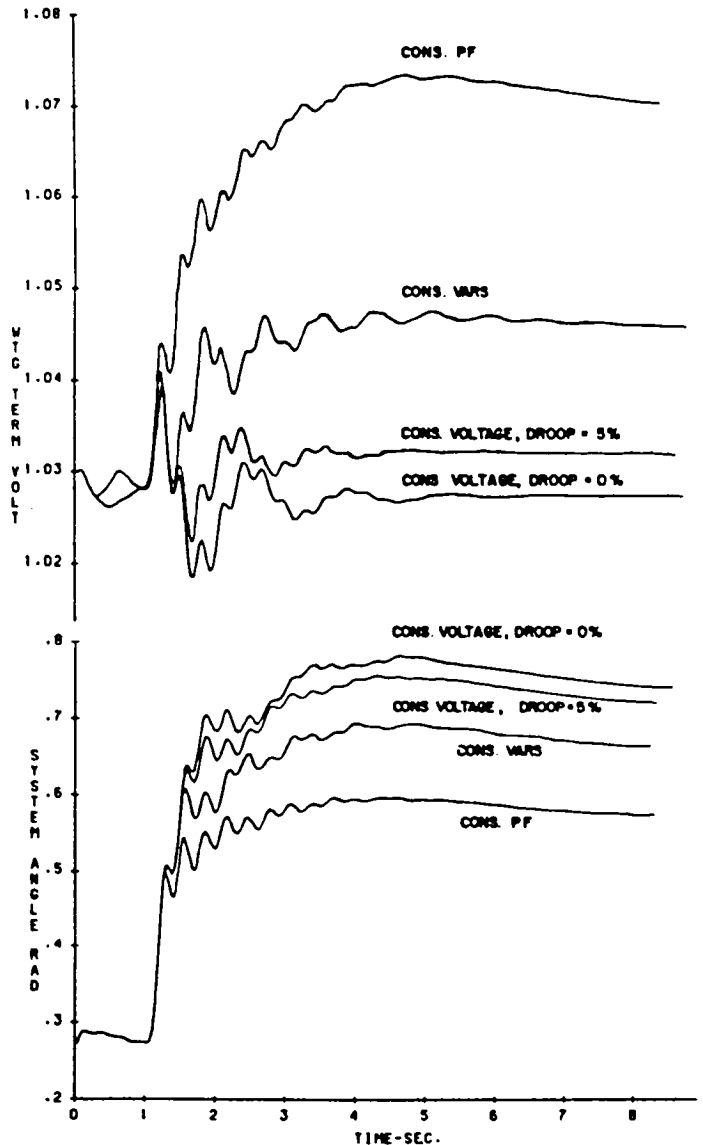

Figure 8 - Model Responses to Wind Torque Step

(Damping Gain, GD = 0.4)

REFERENCES

1. Stiller, P. H., Scott, G. W., Shaltens, R. K., "Measured Effect of Wind Generation on the Fuel Consumption of an Isolated Diesel Power System" presented at the 1983 IEEE Winter Power Meeting.
2. Scott, G. W., Wilreker, V. F., Shaltens, R. K., "Wind Turbine Generator Interaction with Diesel Generators on an Isolated Diesel System," presented at the 1983 IEEE Summer Power Meeting.
3. Seidel, R. C., Gold, H., Wensel, L. M., "Power Train Analyzer for the DOE/NASA 100-kW Wind Turbine Generator," NASA Lewis Research Center, Cleveland, Ohio, DOE/NASA/1028-78/19, NASA TM-78997, October, 1978.

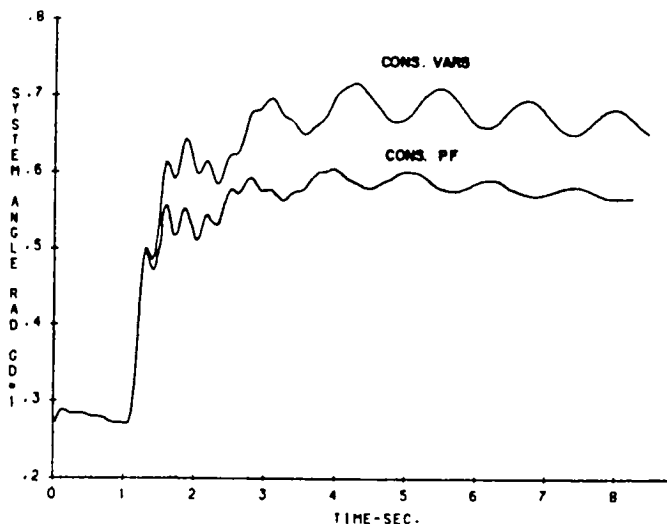

Figure 9 - Sensitivity of var and PF Control Response to Damping Loop Gain GD (Damping Gain, GD = 1.0)

Conclusions

Based on the analysis of the data recordings made on the BIPCO system, comparison among three methods of MOD-OA WTG field excitation (reactive power) control revealed no readily apparent differences in terms of system voltage and frequency (60 Hz) behavior. However, it can be demonstrated by a simulation model that constant power factor control produces a higher transient stability (ability of the WTG to maintain synchronism with the diesel utility) than does either the constant voltage or constant var method.

The low frequency fluctuating reactive power component caused by the combination of MOD-OA WTG, system load and wind dynamics is provided by those generators whose field excitation is under constant voltage control. All generators under fixed excitation or constant power factor control appear to this fluctuating component as an inductive, reactive load, thereby increasing the demand on the voltage controlled generators.

Constant var control has the advantage of providing a non-fluctuating source of reactive power -- a desirable feature when system load is at a low power factor, as was the case during the data collection period on the BIPCO system. At the same time, var control transient stability, while not quite as high as produced by constant power factor control, is higher than that yielded by constant voltage control and is, therefore, a reasonable compromise.

ACKNOWLEDGEMENT

The authors wish to express appreciation to the Block Island Power Company and in particular to Mr. Franklin W. Renz and Mr. Merrill E. Slate, for their cooperation which made this engineering study possible. This study was sponsored by the NASA Lewis Research Center and funded by the United States Department of Energy under Contracts DEN3-275 and DEN3-354.

REFERENCES

1. T. S. Andersen, et al., "MOD-OA 200-kW Wind Turbine Generator Design and Analysis Report," Westinghouse Electric Corporation, for NASA Lewis Research under contract DEN3-163, report no. NASA CR 165128, August, 1980.
2. R. S. Barton, C. E. J. Bowler, and R. J. Pinko, "Control and Stabilization of the DOE/NASA MOD1 Two Megawatt Wind Turbine," Proceedings of the 14th Intersociety Energy Conversion Engineering Conference, Vol. 1, pp. 325-330, August, 1979.
3. A. G. Birchenough, et al., "Operating Experience with Four 200 kW MOD-OA Wind Turbine Generators," Proceedings of the Large Horizontal Axis Wind Turbines Workshop, Cleveland, Ohio, July 28-30, 1981.
4. G. C. Boyer, Diesel and Gas Engine Power Plants, McGraw-Hill, 1943.
5. J. L. Collins, R. K. Shaltens, R. H. Poor, and R. S. Barton, Experience and Assessment of the DOE-NASA MOD-1 2000 Kilowatt Wind Turbine Generator at Boone, North Carolina, NASA TM-82721, 1982.
6. K. T. Fung, R. L. Scheffler, and J. Stolpe, "Wind Energy -- A Utility Perspective," Paper 80 SM 564-5 presented at IEEE Summer Meeting, Minneapolis, 1980.
7. J. C. Glasgow, and A. G. Birchenough: Design and Operating Experience on the U.S. Department of Energy Experimental MOD-0 100-kW Wind Turbine. DOE/NASA/1028-78/18, NASA TM-78915, 1978.
8. J. C. Glasgow, and W. H. Robbins, Utility Operational Experience on the NASA/DPE MOD-OA 200 kW Wind Turbine, NASA TM-79084, 1979.
9. L. N. Hannet, and J. M. Undrill, Wind Turbine Operation in Parallel to Diesel Generation, Power Technologies, Inc. report no. R-42-77, August, 1977.
10. E. N. Hinrichsen and P. J. Nolan, "Dynamics and Stability of Wind Turbine Generators," IEEE Transactions on Power Apparatus and Systems, Vol. PAS-101, pp. 2640-2648, August, 1982.
11. J. M. Kos, "On Line Control of a Large Horizontal Axis Wind Energy Conversion System and its Performance in a Turbulent Wind Environment," Proceedings of the 13th Intersociety Energy Conversion Engineering Conference, pp. 2064-2073, August, 1978.
12. H. E. Neustadter, and D. A. Spera, "Applications of the DOE/NASA Wind Turbine Engineering Information System," NASA Lewis Research Center, Cleveland, Ohio, CP-2185, February, 1981.

13. T. W. Nyland and A. G. Birchenough, A Microprocessor Control System for the 200 Kilowatt MOD-OA Wind Turbine, DOE/NASA/20370-22, NASA TM 82711.
14. T. W. Nyland, MOD-OA Microprocessor Control Function Test In Support of the Block Island Interaction Study, NASA-LeRC Wind Energy Project Office PIR-206, 1982.
15. E. F. Obert, Internal Combustion Engines and Air Pollution," Intext Educational Publishers, New York, N.Y. 1973.
16. T. W. Reddoch and J. W. Klein, "No Ill Winds for New Mexico Utility," IEEE Spectrum, March, 1979.
17. T. W. Reddoch, P. R. Barnes, J. S. Lawler, and J. C. Skroski, "Operational Concepts for Large Wind Turbine Arrays," Proceedings of the 5th Biennial Wind Energy Conference and Workshop, Washington, D.C. October 5-7, 1981.
18. W. H. Robbins and J. E. Sholes, "ERDA/NASA 200-kW MOD-OA Wind Turbine Program," 3rd Biennial Conference and Work Shop on Wind Energy Conversion Systems, CONF-770921/1, September, 1977.
19. R. C. Seidel, H. Gold, and L. M. Wenzel: Power Train Analysis for the DOE/NASA 100-kW Wind Turbine Generator, NASA TM-78997, 1978.
20. R. C. Seidel, and A. G. Birchenough, Variable Gain for A Wind Turbine Pitch Control, NASA TM-82751, 1981.
21. R. K. Shaltens, "MOD-OA Weekly Project Report to DOE," February to May, 1982.
22. R. K. Shaltens and A. G. Birchenough, "Operational Results for the Experimental DOE/NASA MOD-OA Wind Turbine Project," presented at Wind Workshop VI, American Solar Energy Society, Minneapolis, Minnesota, June, 1983 NASA TM-83517.
23. D. Sinclair, Pitch Actuator Performance Test Results MOD-OA-1 200 kW Wind Turbine, Internal NASA Report, July, 1977.
24. T. L. Sullivan, D. R. Miller, D. A. Spera, "Drive Train Manual Modes Analysis for ERDA/NASA 100-Kilowatt Wind Turbine Generator," ERDA/NASA/1028-77/1, NASA TM73718.
25. R. J. Thomas, "A Report on the Block Island Power Company MOD-OA Wind Turbine Project," unpublished report for NASA-LeRC Grant No. NAG3-104, 1982.
26. J. A. Thrift and J. Cerminara, Block Island Diesel Engines Nos. 9 and 10 Excessive Oiling Study, Westinghouse Electric Corporation, NASA Contract DEN3-143, 1980.

27. H. W. Zaininger, et al., Wind Power Generation Dynamic Impacts on Electric Utility Systems, Zaininger Engineering Company, EPRI AP-1614, November, 1980.
28. "Operating Manual: Supplement-Control Performance Criteria," NAPSIC (North American Power Systems Interconnection Committee), April, 1977.
29. "Minimum Performance Criteria - A Supplement to the Operating Manual," NAPSIC (North American Power Systems Interconnection Committee) February, 1972.

1. Report No. NASA CR-168318		2. Government Accession No.		3. Recipient's Catalog No.	
4. Title and Subtitle Wind Turbine Generator Interaction With Conventional Diesel Generators on Block Island, Rhode Island Volume I - Executive Summary				5. Report Date February 1984	
				6. Performing Organization Code	
7. Author(s) V. F. Wilreker, P. H. Stiller, G. W. Scott, V. J. Kruse, and R. F. Smith				8. Performing Organization Report No. AST-84-1808	
				10. Work Unit No.	
9. Performing Organization Name and Address Westinghouse Electric Corporation Advanced Systems Technology 777 Penn Center Blvd. Pittsburgh, Pennsylvania 15235				11. Contract or Grant No. DEN 3-354	
				13. Type of Report and Period Covered Contractor Report	
12. Sponsoring Agency Name and Address U. S. Department of Energy Conservation and Renewable Energy Wind Energy Technology Division Washington D. C. 20545				14. Sponsoring Agency Code- Report No. DOE/NASA/0354-1	
				15. Supplementary Notes Final Report. Prepared under Interagency Agreement DE-AI01-76ET20320. Project Manager, Richard K. Shaltens, NASA Lewis Research Center, Cleveland, Ohio 44135.	
16. Abstract <p>This report summarizes the primary results of a three-part study involving the effects of connecting a MOD-OA wind turbine generator to an isolated diesel power system. The subject utility is that owned and operated by the Block Island Power Company (BIPCO). The MOD-OA installation here was the third of four experimental nominal 200 kW wind turbines connected to various utilities under the Federal Wind Energy Program. The BIPCO installation was characterized by the highest wind energy penetration levels of four sites and, as such, was adjudged the best candidate for conducting the data acquisition and analysis effort that is the subject of this study. The three-phases of the study analysis address: (1) fuel displacement, (2) dynamic interaction, and (3) three modes of reactive power control. These analyses all have as their basis the results of the data acquisition program conducted during 1982 from February into April on Block Island, Rhode Island.</p>					
17. Key Words (Suggested by Author(s)) MOD-OA wind turbine Wind turbine interaction Reactive power control Fuel displacement Utility test experience			18. Distribution Statement Unclassified - unlimited STAR Category 44 DOE Category UC-60		
19. Security Classif. (of this report) Unclassified		20. Security Classif. (of this page) Unclassified		21. No. of pages 47	22. Price* A03

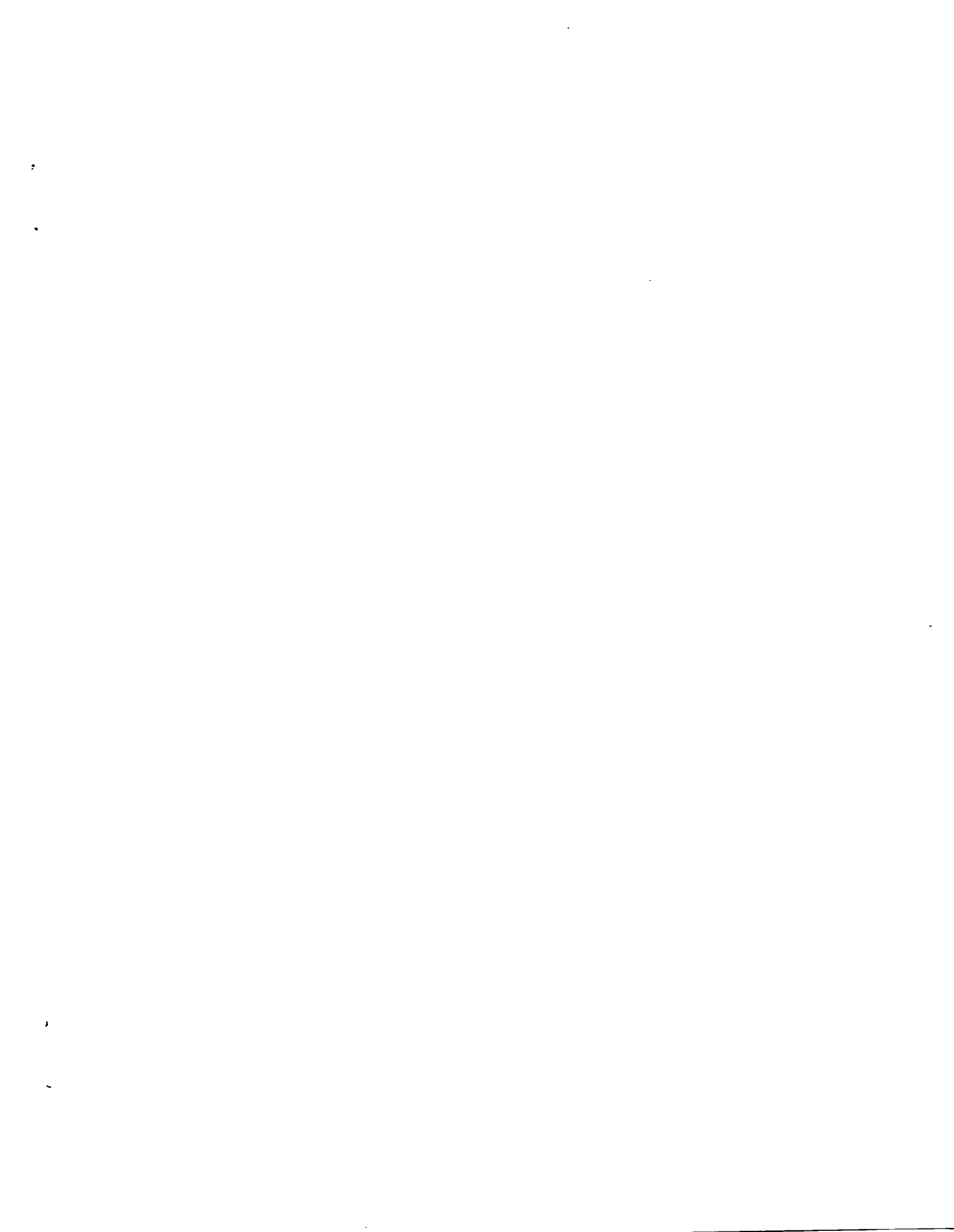

United States Department of Energy
Office of Scientific and Technical Information
Post Office Box 62
Oak Ridge, Tennessee 37831

OFFICIAL BUSINESS
PENALTY FOR PRIVATE USE, \$300

POSTAGE AND FEES PAID
DEPARTMENT OF ENERGY
DOE-350



Postage and Fees Paid
National Aeronautics and
Space Administration
NASA-451

528 FS- 1
NATIONAL AERONAUTICS AND SPACE ADM
ATTN LIBRARY
LANGLEY RESEARCH CENTER
HAMPTON, VA 23665

NASA

POSTMASTER: If Undeliverable (Section 1.5M
Postal Manual) Do Not Return
