

NASA Contractor Report 3822

**Aeroelastic Effects in Multi-Rotor
Vehicles With Application to a
Hybrid Heavy Lift System**

Part I: Formulation of Equations of Motion

C. Venkatesan and P. Friedmann

GRANT NAG2-116
AUGUST 1984



NASA Contractor Report 3822

Aeroelastic Effects in Multi-Rotor Vehicles With Application to a Hybrid Heavy Lift System

Part I: Formulation of Equations of Motion

C. Venkatesan and P. Friedmann

*University of California
Los Angeles, California*

Prepared for
Ames Research Center
under Grant NAG2-116

NASA

National Aeronautics
and Space Administration

Scientific and Technical
Information Branch

1984

PREFACE

This report presents a set of governing coupled differential equations for a model representing a Hybrid Heavy Lift Airship (HHLA). These equations serve as the basis of a numerical study aimed at determining the aeroelastic stability and structural response characteristics of the HHLA. These results will be presented in a follow on report which will represent Part II of this study.

The research effort reported herein was carried out in the Mechanics and Structures Department at UCLA by Dr. C. Venkatesan and Professor P. Friedmann who served as the principal investigator.

The authors want to take this opportunity to express their gratitude to the grant monitor Dr. H. Miura for his numerous constructive comments and suggestions.

TABLE OF CONTENTS

	<u>Page</u>
LIST OF FIGURES	vi
NOMENCLATURE	vii
SUMMARY	1
1. INTRODUCTION.	2
2. AEROELASTIC MODEL OF AN HHLA.	4
2.1 Introduction and Assumption.	4
2.2 Ordering Scheme.	5
3. COORDINATE SYSTEMS.	8
4. MOTION OF THE VEHICLE	13
4.1 Kinematical Relations.	13
5. EQUATIONS OF MOTION FOR THE ROTOR	19
5.1 Blade Cross-sectional Parameters	19
5.2 Equations of Motion for the Individual Blade	21
5.2.1 Distributed Inertia Loads on the Blade	21
5.2.2 Distributed Aerodynamic Loads.	38
5.2.3 Distributed Structural Damping Loads	53
5.2.4 Rotor Blade Equations.	53
6. EQUATIONS OF MOTION OF THE SUPPORTING STRUCTURE	82
6.1 General.	82
6.2 Loads.	82
6.2.1 Rotor Loads.	82
6.2.2 Aerodynamic Loads Due to the Envelope.	87
6.2.3 Thruster Loads	88

	<u>Page</u>
6.2.4 Gravity Loads.	89
6.3 Rigid Body Equations of Motion	91
6.4 Equations of Motion for Elastic Modes.	92
7. CONCLUDING REMARKS.	96
REFERENCES.	98
FIGURES	100
Appendix A: Equivalent Structural Model for Offset Hinged Spring Restrained Blades	111
A.1 General.	111
A.2 Moment Equations for a Hingeless Blade	112
A.3 Moment Equations for an Articulated Blade.	120
A.4 Elastic Restoring Moments on a Rigid Blade with Root Springs and Hub Flexibility.	123
FIGURES	131

LIST OF FIGURES

	<u>Page</u>
1. Hybrid Heavy Lift Airship - Approximate Configuration.	100
2. Sketch Showing the Main Ingredients of the Aeroelastic Model.	101
3. Blade Cross-section Configuration.	102
4. Disturbed Rotor Hub and Rotor Blade Coordinate Systems	103
5. Rotor Blade Coordinate Systems	104
6. Underformed and Deformed k^{th} Blade Cross-sections.	105
7. Deformed k^{th} Blade Cross-section Coordinate Systems.	106
8. Inertial S-Coordinate System	107
9. Body Fixed S1-Coordinate System.	107
10. Geometry for Oscillating Airfoil in Pulsating Flow	108
11. Relative Flow Velocities	109
12. HHLA Model	110
A1. Equivalent Spring Restrained Blade Model	131
A2. Undeformed Axes.	132
A3. Flap Angle	132
A4. Lead-Lag Angle	132
A5. Torsion Angle.	132
A6. Articulated Blade Model.	133
A7. Orientation of the Deformed Blade After Flap and Lag Motion. . . .	133
A8. Equivalent Spring Restrained Blade Model with Hub Flexibility. . .	134

NOMENCLATURE

A_T	- Total cross-sectional area of the blade
a	- Lift curve slope
a_{pk}	- Acceleration of a point p on k^{th} blade
b	- Blade semichord
c_{do}	- Drag coefficient for blade
$C(k)$	- Theodorsen's lift deficiency function
D_B	- Drag force on envelope
D_k	- Drag force per unit length on k^{th} blade
EI_z	- Bending stiffness of the supporting structure in X_s - Y_s plane
EI_y	- Bending stiffness of the supporting structure in X_s - Z_s plane
e	- Blade offset
$\hat{e}_x, \hat{e}_y, \hat{e}_z$	- Unit vectors along X , Y , Z axes
EI_2	- Bending stiffness of blade in lead-lag
EI_3	- Bending stiffness of blade in flap
g_{SF}, g_{SL}, g_{ST}	- Damping coefficients
GJ	- Torsional stiffness of the supporting structure/blade
h_1	- Distance between origin O_s and C.G. of the underslung weight
h_2	- Distance between hub center and C.G. of the fuselage
h_3	- Distance between origin O_s and center of buoyancy of envelope
h_4	- Distance between origin O_s and C.G. of the envelope
h_5	- Distance between C.G. of the supporting structure to the origin O_s
I_{F1}, I_{F2}	- Moments of inertia of the fuselage F_1 and F_2
I_{MB3}, I_{MB2}	- Principal moments of inertia per unit length of the blade about cross-sectional axes
$[I]$	- Inertia tensor

K_{β_B}, K_{ζ_B}	- Root spring stiffness in flap and lag, representing blade stiffness
K_{ϕ_B}, K_{ϕ_C}	- Stiffness of the root springs representing blade torsional stiffness and control link stiffness
K_{β_H}, K_{ζ_H}	- Stiffness of root springs representing hub stiffness in flap and lag
L_1, L_2	- Lift due to rotor systems 1, 2
L_B	- Buoyant lift on envelope
L_C	- Circulatory flow lift
L_{NC}	- Noncirculatory flow lift
l_{F1}, l_{F2}	- Distance between the origin O_s of the supporting structure and C.G.'s of fuselages F_1 and F_2
m	- Mass per unit length of the supporting structure/blade
M_{F1}, M_{F2}	- Fuselage masses of fuselages F_1, F_2
M_a	- Moment due to envelope
M_x, M_y, M_z	- Elastic moments in torsion, flap and lag
N	- Number of blades
$NM, NM1, NM2$	- Number of normal modes used in modeling the supporting structure
O_s	- Origin located at the center line of the supporting structure
O_{H1}, O_{H2}	- Hub Centers
P_{TF1}, P_{TF2}	- Thrust force
P_{T1}, P_{T2}	- Thrust force
P_{Ik}, P_{Ak}, P_{Dk}	- Distributed blade inertia, aerodynamic and damping forces
q_{Ik}, q_{Ak}, q_{Dk}	- Distributed blade inertia, aerodynamic and damping moments
P	- Force
P_{Ik}, P_{Ak}	- Inertia, aerodynamic forces of the rotor blade
Q	- Moment
Q_{Ik}, Q_{Ak}, Q_{Dk}	- Inertia, aerodynamic and damping moments of the rotor blade
R_H	- Perturbational hub motion
R	- Rotor radius
r_{pk}	- Position of vector at a point p on k^{th} blade

t	- Time
u_k, v_k, w_k	- k^{th} blade deformation in axial, lead-lag and flap directions
$v_s, w_s / v_{s1}, w_{s1}$	- Elastic deflection of the supporting structure
V_{Ak}	- Free stream velocity
V_F	- Forward velocity of the vehicle
W_{UN}	- Underslung weight
W	- Weight
X_A	- Offset between the elastic center and the aerodynamic center in blade cross-section
X_I	- Offset between the elastic center and the mass center in blade cross-section
X_T	- Offset between the elastic center and the tension center in blade cross-section
x_k	- Coordinate along k^{th} blade elastic axis
y_{ok}, z_{ok}	- Blade cross-sectional coordinate
α_R	- Angle of forward tilt of the rotor plane
β_p	- Blade precone angle
β_k	- Flap angle for k^{th} blade
ζ_k	- Lead-lag angle for k^{th} blade
ϕ_k	- Torsional angle for k^{th} blade
ϵ	- Basis for orders of magnitude comparison associated with typical elastic blade slopes
η_{ok}, ξ_{ok}	- Blade cross-sectional principal axis coordinate
η_i	- i^{th} mode shape
θ, θ_{ok}	- k^{th} blade collective pitch
θ_{1c}, θ_{1s}	- Cyclic pitch components
θ_{Bk}	- Pretwist in blade
θ_{Gk}	- Geometric pitch in k^{th} blade

$\theta_{zs} - \theta_{ys} - \theta_{xs}$	- Rigid body perturbational rotation in yaw-pitch-roll
λ_k	- Inflow ratio at k^{th} blade
v_k	- Induced velocity at the k^{th} blade cross-section
ρ	- Density of the material of the blade
ρ_A	- Density of air
ϕ_{ik}	- Inflow angle
ϕ_s, ϕ_{s1}	- Elastic twist in supporting frame
μ	- Advance ratio
ψ_k	- Azimuth angle of k^{th} blade
ω_k	- Angular velocity of k^{th} blade
ω_i	- Natural frequency of the supporting structure in i^{th} mode of vibration
Ω	- Rotor r.p.m.

Subscripts

EN	- Envelope
F1, F2	- Fuselages F_1, F_2 / forces acting at fuselage C.G. O_{F1}, O_{F2}
H	- Hub center
H1, H2	- Forces acting at hub center O_{H1}, O_{H2} of rotor systems R_1, R_2
R	- Rotor, quantities refer to R system
S, s	- Supporting structure, s system
S1, s1	- s1 system
T	- Thrust force
UN	- Underslung weight
W	- Gravity loads
x, y, z	- x, y, z components
$()_{,x}$	- $\frac{d}{dx}$
1, 2, 3, 4, 5	- Quantities refer to the corresponding coordinate system

SUMMARY

This report presents a set of governing coupled differential equations for a model representing a Hybrid Heavy Lift Airship (HHLA). The model consists of a bouyant envelope, multiple rotor systems, an underslung weight and thrusters, all attached to a flexible supporting structure. The dynamic equations are written for the individual blade with hub motions, for the rigid body motions of the whole model and also for the flexible modes of the supporting structure. The purpose of these equations is to serve as the basis of a numerical study aimed at determining the aeroelastic stability and structural response characteristics of the HHLA.

1. INTRODUCTION

Hybrid Heavy Lift Airship (HHLA) or Hybrid Heavy Lift Helicopter (HHLH) is useful for providing heavy lift capability whose potential applications are for logging, construction, coast guard surveillance and military heavy lift capability. These vehicles combine a buoyant envelope lift with lift and control forces generated by a multiple rotor system. A rough sketch of a HHLA configuration is shown in Fig. 1. Such a configuration is different from the conventional rotorcraft which have been considered in the past. It is well known that the aeroelastic and structural dynamic response problems are crucial for the safe design of a successful rotorcraft. Therefore it is essential to consider the basic aeroelastic and dynamic behavior of HHLA type vehicles so that the potential aeroelastic instability modes and structural dynamic features can be simulated and identified in the design process.

It has been established that rotary-wing aeroelasticity is inherently nonlinear [Ref. 1]. Aeroelastic studies performed in both industry and research organization are indicative of this aspect. Thus the correct treatment of a wide class of problems in this field requires a consistent development of a mathematical model which includes geometrically nonlinear effects, due to the inclusion of finite slopes in the inertia, structural and aerodynamic operators. It is also well known [Ref. 2] that the unsteady aerodynamic environment in rotorcraft is complicated. Accurate mathematical models, including the unsteady wake effects are rarely incorporated in aeroelastic analyses. In HHLA type vehicles these difficulties will be further compounded by interference buoyant lift. Therefore, it is clear that study of some basic aeroelastic effects in HHLA type vehicles is important for the effective design of such vehicles.

Some of the typical problems that might be encountered by the unique configuration represented by HHLA type vehicles are described below.

(a) Isolated Blade Instabilities: These instabilities are of the flap-lag, flap-pitch or coupled flap-lag-torsion type and can occur both in hover and forward flight. Even if some existing rotor systems which are expected to be free of these isolated blade type instabilities, a wake excited flap-pitch or coupled flap-lag-torsion flutter can occur at low thrust and low inflow

[Refs. 2, 3 and 4]. This situation could potentially be of interest for HHLA type vehicles when the rotors are lightly loaded and the buoyance ratio β is large [buoyance ratio $\beta = \text{buoyant lift/vehicle gross weight}$]. Furthermore, it is reasonable to concentrate primarily on the hover case for HHLA type vehicles because the forward speed of HHLA type vehicles will be low (i.e. $\mu < 0.20$). It was shown [Ref. 5] that forward flight is frequently stabilizing.

(b) Coupled Rotor/Support System Instabilities: A rotor mounted on a moving or flexible support system can have additional instabilities when compared to an isolated blade. On the ground a mechanical instability can occur known as ground resonance [Refs. 2 and 6] and this instability is known to be sensitive to the flexibility and damping of the landing gear system. In flight, the coupled rotor/support system can experience an aeromechanical instability usually denoted as air-resonance [Refs. 2 and 6]. All these instabilities could be encountered in a HHLA type vehicle, because furthermore, the buoyancy effect and the flexibility of the supporting structure could modify these instabilities in an unexpected manner.

(c) Vibration Problems: The vibration levels in helicopters have two peaks, when plotted as a function of advance ratio [Ref. 6]. One peak occurs at relatively low advance ratios and the second at high advance ratios. Since, the advance ratio for the HHLA is low, this type of vehicle could experience considerable vibration levels. Thus, it is necessary to estimate the vibration levels and the resulting dynamic stresses to determine the fatigue life of the structure.

To gain a fundamental understanding of aeroelastic effects which could be encountered on HHLA type vehicles due to their unique features (such as buoyancy, multiple rotors, flexible supporting structure and underslung load), a study of an idealized, simple model, representative of a typical HHLA vehicle, shown in Figure 2, was selected. This report presents a detailed derivation of the equations of equilibrium which cover the dynamics of this system.

2. AEROELASTIC MODEL OF AN HHLA

2.1 Introduction and Assumption

To study the basic aeroelastic problems which could be encountered in an HHLA type configuration, a typical configuration shown schematically in Fig. 2 will be considered. The essential features of the configuration are:

- (a) A flexible supporting structure with bending stiffness $EI_y(x)$ in the X_S-Z_S plane, bending stiffness $EI_z(x)$ in the Y_S-X_S plane (Y_S coordinate is normal to the figure), a torsional rigidity $GJ(x)$ and a mass distribution $m(x)$.
- (b) Two rotor systems capable of providing lift, each having an arbitrary number of blades N , are attached rigidly to the ends of the flexible structure. The distance between the center line of the structure to the hub center for the rotor systems is h_2 .
- (c) Two masses M_{F1} , M_{F2} having inertias I_{F1} and I_{F2} respectively are attached to the ends of the flexible structure. These masses and inertias represent the helicopters. The distance between the origin O_S fixed in the supporting structure to the C.G.'s of the fuselages F_1 and F_2 are l_{F1} and l_{F2} respectively. The C.G. of the supporting structure is at a distance h_5 from the origin O_S . Furthermore it is assumed that the C.G.'s of the supporting structure and fuselages are on the X-axis.
- (d) A weight W_{UN} is attached to the structure. Its C.G. is at a distance h_1 from the origin O_S . This weight can move freely or it can be locked in a fixed position with respect to the flexible structure.
- (e) An envelope, providing the buoyant lift L_B and drag D_B acting at its center of pressure, is attached to the structure. The center of pressure is at a distance h_3 from the origin O_S . The C.G. of the envelope is at a distance h_4 from the origin O_S .
- (f) Concentrated axial loads P_{T1} , P_{T2} simulate thrusters.

Using this model, the dynamic equations of motion for the combined system consisting of two rotors, flexible structure, buoyant envelope and load W_{UN} are derived. The derivation requires four ingredients: blade equations with support motions, equations for the flexible structure connecting the rotors, equations representing the forces and moments introduced by the envelope and finally a representation of the dynamics of the load W_{UN} .

Certain assumptions are introduced before writing the dynamic equations for this system, these are given below:

- (1) The rotor blades are assumed to be rigid with equivalent root springs representing the flexibility of the blade.
- (2) The rotor blades are attached to the hub with an offset e from the axis of rotation (Hub center).
- (3) The blade feathering axis is precone by an angle β_p . The blade has no torque offset, sweep or droop.
- (4) The feathering axis coincides with the elastic axis of the blade.
- (5) The blade cross-section is symmetric and has four distinct points: elastic center, mass center, aerodynamic center and tension center (Fig. 3).
- (6) The structural damping in the blade is assumed to be of the viscous type.
- (7) The rotor shaft is rigid.
- (8) The rotor speed is constant.
- (9) The rotor consists of three or more blades.
- (10) Two-dimensional quasi-steady aerodynamics is used to obtain the aerodynamic loads. There is no reverse flow and stall. The compressibility effect is neglected.
- (11) The C.G. of the fuselages are on the center line of the supporting structure such that the individual C.G.'s lie on a straight line.
- (12) The underslung mass is rigidly attached to the structure.
- (13) The elastic deformations of the supporting structure are at least one order of magnitude lower than that of the blade deformation.
- (14) Flexible structure is modeled by using free-free beam modes with arbitrary mass and stiffness distribution.
- (15) Aerodynamic forces and moments due to the envelope are modeled by using the model provided in Ref. 7. Quasisteady aerodynamic theory is used for blade aerodynamics, and aerodynamic interference between the rotor and the envelope is neglected.

Based on these assumptions, the dynamic equations of motion for the model are derived, using force and moment equilibrium conditions at the connecting points as was done in Ref. 8.

2.2 Ordering Scheme

When deriving equations of motion for such a multi-rotor system, a large number of higher order terms has to be considered. Previous research has clearly indicated that many higher order terms can be neglected systematically by using

an ordering scheme [Refs. 1,8]. Warmbrodt and Friedmann [Ref. 8] and Levin* have, in their derivation of coupled rotor/fuselage equations, assigned in a judicious manner, appropriate orders of magnitude for various terms encountered in the coupled rotor/fuselage equations. The ordering scheme employed in this study follows this approach. By assuming fuselage rotations of order ϵ many additional terms will appear in the coupled rotor/fuselage equations. Such an ordering scheme was recently used in Ref. 9. In the earlier derivations, the fuselage was assumed to have only rigid body degrees of freedom and the orders of magnitude of the corresponding perturbed quantities are $O(\epsilon^{3/2})$. In the present case, the fuselage/supporting structure is being considered flexible and orders of magnitude are assigned also to the deformation of the supporting structure. An order of magnitude of $O(\epsilon^2)$ is assigned to the elastic deformations of the structure so that this effect appears in the hub motion while at the same time the number of terms in the equations remains manageable.

The basis of the ordering scheme is a small dimensionless parameter ϵ which represents typical blade slopes due to elastic deflections. It is known that for helicopter blades ϵ is in the range

$$0.1 \leq \epsilon \leq 0.2$$

The ordering scheme is based on the assumption that

$$1 + O(\epsilon^2) \approx 1$$

i.e. terms of the order of $O(\epsilon^2)$ are neglected in comparison with unity. The orders of magnitude for the various parameters governing this problem are given below.

$$\cos\psi_k, \sin\psi_k, \frac{x_k}{R}, \frac{\rho_A abR}{m}, \frac{h_1}{R}, \frac{h_2}{R}, \frac{h_3}{R}, \frac{h_4}{R}, \frac{h_5}{R}, \frac{l_{F1}}{R}, \frac{l_{F2}}{R} = O(1)$$

$$\frac{1}{\Omega} \frac{\partial}{\partial t} () = \frac{\partial}{\partial \psi} () = O(1)$$

$$\frac{R}{\partial x_k} \frac{\partial}{\partial x_k} () = \frac{\partial}{\partial \bar{x}_k} = O(1)$$

$$\theta_{ok}, \theta_{Gk} = O(\epsilon^{1/2})$$

* J. Levin, "Formulation of Helicopter Air Resonance Problem in Hover with Active Controls", M.S. Thesis, Mechanics and Structures Department, University of California, Los Angeles, September 1981.

$$\beta_k, \phi_k, \psi_k, \frac{e}{R}, \frac{b}{R}, \beta_p, \lambda_k, \dot{\theta}_{Gk}, \ddot{\theta}_{Gk} = O(\varepsilon)$$

$$\frac{C_{d0}}{a}, \frac{R_{xs}}{R}, \frac{R_{ys}}{R}, \frac{R_{zs}}{R}, \theta_{xs}, \theta_{ys}, \theta_{zs} = O(\varepsilon^{3/2})$$

$$\frac{u_k}{R}, \frac{x_A}{R}, \frac{x_I}{R}, \frac{w_s}{R}, \frac{v_s}{R} = O(\varepsilon^2)$$

$$\frac{x_T}{R} = O(\varepsilon^3)$$

$$w_{s,x}, v_{s,x}, \phi_s = O(\varepsilon^{7/2})$$

$$\frac{I_{MB3}}{mR^2} = O(\varepsilon^3)$$

$$\frac{I_{MB2}}{mR^2} = O(\varepsilon^7)$$

3. COORDINATE SYSTEMS

In the derivation of equations of motion of the HHLA model, various reference coordinate systems are used. The transformation relation between quantities referred in the various inertial, noninertial coordinate systems to be established before deriving the equations of motion. The relation between two orthogonal coordinate systems with axes X_i, Y_i, Z_i and X_j, Y_j, Z_j with $\hat{e}_{xi}, \hat{e}_{yi}, \hat{e}_{zi}$ and $\hat{e}_{xj}, \hat{e}_{yj}, \hat{e}_{zj}$ as unit vectors along the respective axes is

$$\begin{pmatrix} \hat{e}_{xi} \\ \hat{e}_{yi} \\ \hat{e}_{zi} \end{pmatrix} = [T_{ij}] \begin{pmatrix} \hat{e}_{xj} \\ \hat{e}_{yj} \\ \hat{e}_{zj} \end{pmatrix} \quad (3.1)$$

where $[T_{ij}]$, the transformation matrix, can be found using the Euler angles required to rotate the j-system so as to make it parallel to i-system.

The S-system (Fig.2) is an inertial system whose origin O_s is fixed at the center line of the supporting structure in the unperturbed state with the Z_s axis vertically upwards passing through the center of gravity of the envelope and X_s is directed aft.

The Sl-system is a noninertial coordinate system whose origin is also fixed at the same point O_s of the supporting structure. This is a body fixed coordinate system which moves along with the body during perturbational motion. The S-system and Sl-system coincide with each other in the unperturbed state of the model.

The R-system is another inertial system fixed at the center O_H of the unperturbed hub. The directions of the axes of this system are parallel to that of the S-system. It should be noted that in the development of rotor blade equations, only one general rotor system with hub motions is considered. Consequently one set of rotor coordinate systems will be defined. These definitions are valid for all the rotor systems in the model. The only difference that will occur are the different hub motions due to the relative positions of the hubs with respect to the origin of the S-system. This is accounted for in the derivation by deriving a general expression for the motion of hub center O_H due to the rigid body translation and rotation and due to the elastic deformations of the supporting structure.

The l-system is a body fixed system with its origin fixed at the center of the hub O_H (Fig. 4). Prior to perturbational motion the l-system coincides with the R-system. It is assumed that the l-system and Sl-system are parallel systems, because as pointed out earlier that the elastic deformation slopes of the supporting structure are of order $O(\epsilon^{7/2})$. So any small rotational motion given to the hub fixed l-system, due to the elastic deformation of the supporting structure, is assumed negligible.

The perturbational translational motion at the hub center O_H due to the rigid body motion and the elastic deformation of the structure is written as

$$\bar{R}_H = R_x \hat{e}_{xR} + R_y \hat{e}_{yR} + R_z \hat{e}_{zR} \quad (3.2)$$

and if $\theta_x, \theta_y, \theta_z$ represent the yaw-pitch-roll rotations of the structure then the transformation matrix $[T_{lR}]$ can be written as

$$[T_{lR}] = \begin{bmatrix} 1 & 0 & 0 \\ 0 & \cos\theta_x & \sin\theta_x \\ 0 & -\sin\theta_x & \cos\theta_x \end{bmatrix} \begin{bmatrix} \cos\theta_y & 0 & -\sin\theta_y \\ 0 & 1 & 0 \\ \sin\theta_y & 0 & \cos\theta_y \end{bmatrix} \begin{bmatrix} \cos\theta_z & \sin\theta_z & 0 \\ -\sin\theta_z & \cos\theta_z & 0 \\ 0 & 0 & 1 \end{bmatrix}$$

Since $\theta_x, \theta_y, \theta_z$ are of order $\theta(\epsilon^{3/2})$, the sines and cosines can be replaced with $\sin \theta \approx \theta$ and $\cos \theta \approx 1$. Thus

$$[T_{lR}] = \begin{bmatrix} 1 & \theta_z & -\theta_y \\ \theta_y \theta_x - \theta_z & 1 & \theta_x \\ \theta_z \theta_x + \theta_y & \theta_z \theta_y - \theta_x & 1 \end{bmatrix} \quad (3.3)$$

Rotating 2k-system is a blade fixed coordinate system which rotates with the k^{th} blade. This 2k-system is rotated from the l-system by the azimuth angle, ψ_k , of the k^{th} blade (Fig. 4) about Z_l axis. The transformation matrix is

$$[T_{2l}] = \begin{bmatrix} \cos\psi_k & \sin\psi_k & 0 \\ -\sin\psi_k & \cos\psi_k & 0 \\ 0 & 0 & 1 \end{bmatrix} \quad (3.4)$$

Rotating the 2k-system by an angle $-\beta_p$ (precone angle) about Y_{2k} -axis and translating the origin to the k^{th} blade bearing by a distance $e \hat{e}_{x2k}$, gives the 3k-system (Fig. 5). The X_{3k} -axis is along the elastic axis of the undeformed k^{th} blade. Since β_p is of the order $\theta(\epsilon)$, $\sin \beta_p \approx \beta_p$ and $\cos \beta_p \approx 1$. The rotation matrix is

$$[T_{32}] = \begin{bmatrix} 1 & 0 & \beta_p \\ 0 & 1 & 0 \\ -\beta_p & 0 & 1 \end{bmatrix} \quad (3.5)$$

The 4k-system (Fig. 6) is fixed in the cross-section of the k^{th} blade. Translating 3k system an amount $x_k \hat{e}_{x3k}$ gives the 4k system at the cross-section x_k of the k^{th} blade prior to elastic deformation. During elastic deformation of the k^{th} blade, i.e., flap, lag and torsion, the 4k system translates and rotates with the cross-section. The origin of the 4k system after the deformation is given as

$$(x_k + u_k) \hat{e}_{x3k} + v_k \hat{e}_{y3k} + w_k \hat{e}_{z3k} \quad (3.6)$$

The rotation of the 4k system is obtained by Euler angles $-\beta_k, \zeta_k, \phi_k$. These angles represent the flap-lag-torsional rotation of the k^{th} blade at location x_k . The sequence of rotation is flap-lag-torsion. The transformation matrix $[T_{43}]$ is

$$[T_{43}] = \begin{bmatrix} 1 & 0 & 0 \\ 0 & \cos\phi_k & \sin\phi_k \\ 0 & -\sin\phi_k & \cos\phi_k \end{bmatrix} \begin{bmatrix} \cos\zeta_k & \sin\zeta_k & 0 \\ -\sin\zeta_k & \cos\zeta_k & 0 \\ 0 & 0 & 1 \end{bmatrix} \begin{bmatrix} \cos\beta_k & 0 & \sin\beta_k \\ 0 & 1 & 0 \\ -\sin\beta_k & 0 & \cos\beta_k \end{bmatrix}$$

Since the angles $\phi_k, \zeta_k, \beta_k \approx \theta(\epsilon)$, the transformation matrix can be simplified by assuming $\sin \theta \approx \theta$ and $\cos \theta \approx 1$, and be written as

$$[T_{43}] = \begin{bmatrix} 1 & \zeta_k & \beta_k \\ -\zeta_k - \phi_k \beta_k & 1 & \phi_k - \beta_k \zeta_k \\ -\beta_k + \phi_k \zeta_k & -\phi_k & 1 \end{bmatrix} \quad (3.7)$$

In our model, we have considered the blade as a rigid blade with root springs. So, the relation between the translation and rotation is

$$v_k = x_k \zeta_k \quad \text{and} \quad w_k = -(-x_k \beta_k) = x_k \beta_k \quad (3.8)$$

To facilitate the description of the blade element aerodynamics, the 5k system (Fig. 7) is defined by removing the torsional twisting of the blade from the 4k system which gives the rotation matrix

$$[T_{54}] = \begin{bmatrix} 1 & 0 & 0 \\ 0 & \cos(-\phi_k) & \sin(-\phi_k) \\ 0 & -\sin(-\phi_k) & \cos(-\phi_k) \end{bmatrix} \quad (3.9)$$

when ϕ_k is small, it can be written as

$$[T_{54}] = \begin{bmatrix} 1 & 0 & 0 \\ 0 & 1 & -\phi_k \\ 0 & \phi_k & 1 \end{bmatrix} \quad (3.10)$$

Summary of Coordinate Systems

<u>Symbol</u>	<u>Coordinate System</u>	<u>Unit Vectors</u>
S	Inertial system. Origin O_s fixed at the center line of the undistrubed supporting structure with Z_s axis pass-through the C.G. of the envelope	$\hat{e}_{xs}, \hat{e}_{ys}, \hat{e}_{zs}$
S1	Noninertial body fixed. Origin at the point O_s on the supporting structure	$\hat{e}_{xs1}, \hat{e}_{ys1}, \hat{e}_{zs1}$
R	Inertial. Fixed at the undeformed hub center O_H . S and R are parallel systems	$\hat{e}_{Rx}, \hat{e}_{Ry}, \hat{e}_{Rz}$
l	Noninertial body fixed. Origin at the center of rotor hub O_H . S1 and l are parallel systems	$\hat{e}_{xl}, \hat{e}_{yl}, \hat{e}_{zl}$

2k	Rotates with k^{th} blade. Origin at the center of the rotor hub O_H	$\hat{e}_{x2k}, \hat{e}_{y2k}, \hat{e}_{z2k}$
3k	Rotates with k^{th} blade. Origin at the k^{th} blade pitch bearing. Preconed. x_{3k} axis coincident with blade elastic axis in undeformed position	$\hat{e}_{x3k}, \hat{e}_{y3k}, \hat{e}_{z3k}$
4k	Rotates with k^{th} blade. Origin at the elastic axis of the deformed blade cross-section at a distance x_k	$\hat{e}_{x4k}, \hat{e}_{y4k}, \hat{e}_{z4k}$
5k	Rotates with k^{th} blade. Origin at the elastic axis of the deformed blade cross-section at a distance x_k . Torsional rotation of the blade not included	$\hat{e}_{x5k}, \hat{e}_{y5k}, \hat{e}_{z5k}$

4. MOTION OF THE VEHICLE

The unconstrained vehicle has six rigid body degrees of freedom and also has elastic deformation of the supporting structure. Before presenting the equations of motion for the blade and the structure, it is necessary to establish certain kinematical relations between the vehicle motion and the hub displacement, because the blade inertia and aerodynamic loads are affected by the hub displacement. In this section, the position vector of the origin of the hub centers O_{H1} and O_{H2} and the rotation vector at the rotor systems, due to the perturbations in rigid body translation and rotation, and elastic deformation of the supporting structure, is derived. Subsequently these expressions are used in writing the blade loads.

4.1 Kinematical Relations

The sequence of perturbational motion of the vehicle model [Fig. 8], assumed to take place, consists first of rigid body translation of the origin O_s of the supporting structure, i.e. origin of the S-system, then rigid body rotation in the sequence yaw-pitch-roll and finally in the perturbed position, the elastic deformation of the structure. Referring to Fig. 8, the perturbational translational motion occurs along X_s , Y_s and Z_s coordinate axes. After the rigid body rotation, the body fixed axes system is referred as Sl-system. The elastic deformations occur in the Sl-system [Fig. 9].

During rigid body perturbational translation, the origin O_s is moved through a distance,

$$\bar{R}_{O_s} = R_{x_s} \hat{e}_{x_s} + R_{y_s} \hat{e}_{y_s} + R_{z_s} \hat{e}_{z_s} \quad (4.1)$$

Then the model is rotated about Z_s axis through an angle θ_{z_s} representing yaw motion, followed by a rotation θ_{y_s} about the yawed Y_s axis representing pitch. To represent roll, a rotation θ_{x_s} is introduced about the yawed-pitched X_s axis. The new position of the body axis system is Sl. The transformation of unit vectors from Sl-system to S-system is given by

$$\begin{Bmatrix} \hat{e}_{xs} \\ \hat{e}_{ys} \\ \hat{e}_{zs} \end{Bmatrix} = \begin{bmatrix} 1 & -\theta_{zs} + \theta_{xs} \theta_{ys} & \theta_{ys} + \theta_{zs} \theta_{xs} \\ \theta_{zs} & 1 & -\theta_{xs} + \theta_{ys} \theta_{zs} \\ -\theta_{ys} & \theta_{xs} & 1 \end{bmatrix} \begin{Bmatrix} \hat{e}_{xs1} \\ \hat{e}_{ys1} \\ \hat{e}_{zs1} \end{Bmatrix} \quad (4.2)$$

Figure 9 refers to the perturbed state of the model after rigid body motion. It is assumed that the elastic deformations of the structure occur in this state. The elastic deformations are bending in X_{s1}, Y_{s1} plane, bending in X_{s1}, Z_{s1} plane and torsion about X_{s1} axis. The deformations are represented by

1. v_{s1} along Y_{s1}
2. w_{s1} along Z_{s1}
3. ϕ_{s1} along X_{s1}

Position vector of the C.G. of the fuselage F_2 (is point O_{F2}) after the deformation is

$$\bar{r}_{OF2} = l_{F2} \hat{e}_{xs1} + v_{s1} |_{l_{F2}} \hat{e}_{ys1} + w_{s1} |_{l_{F2}} \hat{e}_{zs1} \quad (4.3)$$

where the symbol $|_{l_{F2}}$ refers to the value of the appropriate displacement at location l_{F2} .

The position vector of the origin of hub in rotor system 2 (i.e. point O_{H2}) after the elastic deformation is

$$\begin{aligned} \bar{r}_{OH2} = & (l_{F2} - h_2 w_{s1,x} |_{l_{F2}}) \hat{e}_{xs1} + (v_{s1} |_{l_{F2}} - h_2 \phi_{s1} |_{l_{F2}}) \hat{e}_{ys1} \\ & + (h_2 + w_{s1} |_{l_{F2}}) \hat{e}_{zs1} \end{aligned} \quad (4.4)$$

Due to these deformations, there is also a rotation. The rotation along axes at O_{F2} and O_{H2} are given by

$$\bar{\theta}_{OF2} = \bar{\theta}_{OH2} = \phi_{s1} |_{l_{F2}} \hat{e}_{xs1} - w_{s1,x} |_{l_{F2}} \hat{e}_{ys1} + v_{s1,x} |_{l_{F2}} \hat{e}_{zs1} \quad (4.5)$$

Using equations 4.1, 4.2 and 4.4, the position vector of O_{H2} after the perturbational rigid body motions and the elastic deformation, can be written as (in the inertial system S)

$$\begin{aligned}
\bar{R}_{OH2} = & [R_{xs} + (\ell_{F2} - h_2 w_{s1,x}|_{\ell_{F2}}) + (v_{s1}|_{\ell_{F2}} - h_2 \phi_{s1}|_{\ell_{F2}})(-\theta_{zs} + \theta_{xs} \theta_{ys}) \\
& + (h_2 + w_{s1}|_{\ell_{F2}})(\theta_{ys} + \theta_{zs} \theta_{xs})] \hat{e}_{xs} \\
& + [R_{ys} + (\ell_{F2} - h_2 w_{s1,x}|_{\ell_{F2}})\theta_{zs} + (v_{s1}|_{\ell_{F2}} - h_2 \phi_{s1}|_{\ell_{F2}}) \\
& + (h_2 + w_{s1}|_{\ell_{F2}})(-\theta_{xs} + \theta_{ys} \theta_{zs})] \hat{e}_{ys} \\
& + [R_{zs} + (\ell_{F2} - h_2 w_{s1,x}|_{\ell_{F2}})(-\theta_{ys}) + (v_{s1}|_{\ell_{F2}} - h_2 \phi_{s1}|_{\ell_{F2}})\theta_{xs} \\
& + (h_2 + w_{s1}|_{\ell_{F2}})] \hat{e}_{zs} \quad (4.6)
\end{aligned}$$

This relation can be more compactly written as

$$\bar{R}_{OH2} = R_x \hat{e}_{xs} + R_y \hat{e}_{ys} + R_z \hat{e}_{zs} \quad (4.7)$$

The perturbational displacement at the hub center O_{H1} of the rotor system 1 can be obtained by replacing ℓ_{F2} in Eq. 4.6 by $-\ell_{F1}$.

The velocity at O_{H2} due these perturbational motions is

$$\begin{aligned}
\dot{\bar{R}}_{OH2} = & \Omega [\dot{R}_{xs} - h_2 \dot{w}_{s1,x}|_{\ell_{F2}} + h_2 (\dot{\theta}_{ys} + \dot{\theta}_{zs} \theta_{xs} + \theta_{zs} \dot{\theta}_{xs})] \hat{e}_{xs} \\
& + \Omega [\dot{R}_{ys} + \ell_{F2} \dot{\theta}_{xs} + \dot{v}_{s1}|_{\ell_{F2}} - h_2 \dot{\phi}_{s1}|_{\ell_{F2}} \\
& + h_2 (-\dot{\theta}_{xs} + \dot{\theta}_{ys} \theta_{zs} + \theta_{ys} \dot{\theta}_{zs})] \hat{e}_{ys} \\
& + \Omega [\dot{R}_{zs} - \ell_{F2} \dot{\theta}_{ys} + \dot{w}_{s1}|_{\ell_{F2}}] \hat{e}_{zs} \quad (4.8)
\end{aligned}$$

where $(\dot{})$ indicates derivative with respect to the nondimensional parameter ψ , ($\psi = \Omega t$). The acceleration at O_{H2} due to these perturbational motion is

$$\begin{aligned} \ddot{\bar{R}}_{OH2} = & \Omega^2 [\ddot{R}_{xs} - h_2 \ddot{w}_{s1,x}|_{\ell_{F2}} + h_2 (\ddot{\theta}_{ys} + \ddot{\theta}_{zs} \theta_{xs} + 2\dot{\theta}_{zs} \dot{\theta}_{xs} + \theta_{zs} \ddot{\theta}_{xs}) \hat{e}_{xs} \\ & + \Omega^2 [\ddot{R}_{xs} + \ell_{F2} \ddot{\theta}_{xs} + \ddot{v}_{x1}|_{\ell_{F2}} - h_2 \ddot{\phi}_{s1}|_{\ell_{F2}} \\ & + h_2 (-\ddot{\theta}_{xs} + \ddot{\theta}_{ys} \theta_{zs} + 2\dot{\theta}_{ys} \dot{\theta}_{zs} + \theta_{ys} \ddot{\theta}_{zs})] \hat{e}_{ys} \\ & + \Omega^2 [\ddot{R}_{zs} - \ell_{F2} \ddot{\theta}_{ys} + \ddot{w}_{s1}|_{\ell_{F2}}] \hat{e}_{zs} \end{aligned} \quad (4.9)$$

Equations 4.8 and 4.9 can be more compactly written as

$$\dot{\bar{R}}_{OH2} = (\dot{R}_x \hat{e}_{xs} + \dot{R}_y \hat{e}_{ys} + \dot{R}_z \hat{e}_{zs}) \Omega \quad (4.10)$$

$$\ddot{\bar{R}}_{OH2} = (\ddot{R}_x \hat{e}_{xs} + \ddot{R}_y \hat{e}_{ys} + \ddot{R}_z \hat{e}_{zs}) \Omega^2 \quad (4.11)$$

The perturbational velocity and acceleration at the hub center O_{H1} can be obtained by replacing ℓ_{F2} in Equations 4.8 and 4.9 by $-\ell_{F1}$.

Rigid body angular velocities are $\dot{\theta}_{zs} \Omega$ about Z_s axis and $\dot{\theta}_{ys} \Omega$ about yawed Y_s -axis and $\dot{\theta}_{xs} \Omega$ about yawed-pitched X_s axis. The angular velocity of the model due to rigid body rotation alone is

$$\begin{aligned} \bar{\omega}_{rigid} = & \Omega (\dot{\theta}_{xs} - \dot{\theta}_{ys} \theta_{zs}) \hat{e}_{xs} + \Omega (\dot{\theta}_{ys} + \dot{\theta}_{xs} \theta_{zs}) \hat{e}_{ys} \\ & + \Omega (\dot{\theta}_{zs} - \dot{\theta}_{xs} \theta_{ys}) \hat{e}_{zs} \end{aligned} \quad (4.12)$$

Angular velocity at O_{F2} and O_{H2} due to elastic deformation is (from equation 4.5)

$$\bar{\omega}_E = \Omega (\dot{\phi}_{s1}|_{\ell_{F2}} \hat{e}_{xs1} - \dot{w}_{s1,x}|_{\ell_{F2}} \hat{e}_{ys1} + \dot{v}_{s1,x}|_{\ell_{F2}} \hat{e}_{zs1}) \quad (4.13)$$

Combining equations (4.12) and (4.13), using equation (4.2), the angular velocity at the rotor hub due to the elastic deformation and due to the rigid

body rotation can be obtained. The angular velocity given in the s-system is

$$\begin{aligned}
\bar{\omega}_{OH2} = & \Omega(\dot{\theta}_{xs} - \dot{\theta}_{ys} \theta_{zs}) \hat{e}_{xs} + \Omega(\dot{\theta}_{ys} + \dot{\theta}_{xs} \theta_{zs}) \hat{e}_{ys} + \Omega(\dot{\theta}_{zs} - \dot{\theta}_{xs} \theta_{ys}) \hat{e}_{zs} \\
& + \Omega[\dot{\phi}_{s1}|_{\ell_{F2}} - \dot{w}_{s1,x}|_{\ell_{F2}} (-\theta_{zs} + \theta_{xs} \theta_{ys}) + \dot{v}_{s1,x}|_{\ell_{F2}} (\theta_{ys} + \theta_{zs} \theta_{xs})] \hat{e}_{xs} \\
& + \Omega[\dot{\phi}_{s1}|_{\ell_{F2}} \theta_{zs} - \dot{w}_{s1,x}|_{\ell_{F2}} + \dot{v}_{s1,x}|_{\ell_{F2}} (-\theta_{xs} + \theta_{ys} \theta_{zs})] \hat{e}_{ys} \\
& + \Omega[-\dot{\phi}_{s1}|_{\ell_{F2}} \theta_{ys} - \dot{w}_{s1,x}|_{\ell_{F2}} \theta_{xs} + \dot{v}_{s1,x}|_{\ell_{F2}}] \hat{e}_{zs}
\end{aligned}$$

which can be simplified to

$$\begin{aligned}
\bar{\omega}_{OH2} = & \Omega[(\dot{\theta}_{xs} - \dot{\theta}_{ys} \theta_{zs} + \dot{\phi}_{s1}|_{\ell_{F2}}) \hat{e}_{xs} \\
& + (\dot{\theta}_{ys} + \dot{\theta}_{xs} \theta_{zs} - \dot{w}_{s1,x}|_{\ell_{F2}}) \hat{e}_{ys} \\
& + (\dot{\theta}_{zs} - \dot{\theta}_{xs} \theta_{ys} + \dot{v}_{s1,x}|_{\ell_{F2}}) \hat{e}_{zs}] \quad (4.14)
\end{aligned}$$

The Angular acceleration is

$$\begin{aligned}
\dot{\bar{\omega}}_{OH2} = & \Omega^2[(\ddot{\theta}_{xs} - \ddot{\theta}_{ys} \theta_{zs} - \dot{\theta}_{ys} \dot{\theta}_{zs} + \ddot{\phi}_{s1}|_{\ell_{F2}}) \hat{e}_{xs} \\
& + (\ddot{\theta}_{ys} + \ddot{\theta}_{xs} \theta_{zs} + \dot{\theta}_{xs} \dot{\theta}_{zs} - \ddot{w}_{s1,x}|_{\ell_{F2}}) \hat{e}_{ys} \\
& + (\ddot{\theta}_{zs} - \ddot{\theta}_{xs} \theta_{ys} - \dot{\theta}_{xs} \dot{\theta}_{ys} + \ddot{v}_{s1,x}|_{\ell_{F2}}) \hat{e}_{zs}] \quad (4.15)
\end{aligned}$$

The angular velocity and acceleration at O_{H1} is obtained by replacing ℓ_{F2} by $-\ell_{F1}$ in equation (4.14) and (4.15).

Assuming the rotations due to the elastic deformation of the supporting structure to be small compared to those due of the rigid body rotation, causes the angular velocity at the hub to be a result of rigid body rotation alone.

Thus this expression becomes

$$\begin{aligned} \bar{\omega}_{OH2} = \Omega [& (\dot{\theta}_{xs} - \dot{\theta}_{ys} \theta_{zs}) \hat{e}_{xs} + (\dot{\theta}_{ys} + \dot{\theta}_{xs} \theta_{zs}) \hat{e}_{ys} \\ & + (\dot{\theta}_{zs} - \dot{\theta}_{xs} \theta_{ys}) \hat{e}_{zs}] \end{aligned} \quad (4.16)$$

and

$$\begin{aligned} \dot{\bar{\omega}}_{OH2} = \Omega^2 [& (\ddot{\theta}_{xs} - \ddot{\theta}_{ys} \theta_{zs} - \dot{\theta}_{ys} \dot{\theta}_{zs}) \hat{e}_{xs} \\ & + (\ddot{\theta}_{ys} + \ddot{\theta}_{xs} \theta_{zs} + \dot{\theta}_{xs} \dot{\theta}_{zs}) \hat{e}_{ys} \\ & + (\ddot{\theta}_{zs} - \ddot{\theta}_{xs} \theta_{ys} - \dot{\theta}_{xs} \dot{\theta}_{ys}) \hat{e}_{zs}] \end{aligned} \quad (4.17)$$

In the equations which follow the subscript s on the rotations will be deleted, since they are in essence rigid body rotations.

Equations (4.8), (4.9), (4.16) and (4.17) will be used for deriving the inertia and aerodynamic loads on the rotor blades.

5. EQUATIONS OF MOTION FOR THE ROTOR

When modelling the behavior of rotors the individual blades are considered first, the equations of motion of the individual blade is derived by writing the equation of dynamic equilibrium under the action of aerodynamic, inertia and structural loads. These equations are derived for the general k^{th} blade. Subsequently these equations are coupled with the fuselage motion to provide the complete set of dynamical equations of motion for HHLA vehicle model [Fig. 2].

5.1 Blade Cross-Sectional Parameters

In the derivation of the equations of motion of the blade, certain cross-sectional parameters described below, are required. The 4k-system is the cross-sectional coordinate system. The location of any point in the cross-section from the origin of the 4k-system is

$$y_{ok} \hat{e}_{y4k} + z_{ok} \hat{e}_{z4k}$$

The principal axes of the symmetric blade cross-section are rotated from the 4k-system by the geometric pitch angle θ_{Gk} [Fig. 6].

The geometrical pitch angle is defined as

$$\theta_{Gk} = \theta_{Bk}(x) + \theta_{ok} + \theta_{lck} \cos\psi_k + \theta_{isk} \sin\psi_k \quad (5.1)$$

where $\theta_{Bk}(x)$ is the pretwist

θ_{ok} is collective pitch

θ_{lck} and θ_{isk} are cyclic pitch components

If η_{ok} and ξ_{ok} are the principal axes coordinates, the transformation for y_{ok} and z_{ok} is given by

$$\begin{Bmatrix} y_{ok} \\ z_{ok} \end{Bmatrix} = \begin{bmatrix} \cos \theta_{Gk} & -\sin \theta_{Gk} \\ \sin \theta_{Gk} & \cos \theta_{Gk} \end{bmatrix} \begin{Bmatrix} \eta_{ok} \\ \xi_{ok} \end{Bmatrix} \quad (5.2)$$

Differentiating equation (5.2) with respect to ψ yields

$$\begin{pmatrix} \dot{y}_{ok} \\ \dot{z}_{ok} \end{pmatrix} = \dot{\theta}_{Gk} \begin{pmatrix} -z_{ok} \\ y_{ok} \end{pmatrix} \quad (5.3)$$

and

$$\begin{pmatrix} \ddot{y}_{ok} \\ \ddot{z}_{ok} \end{pmatrix} = \ddot{\theta}_{Gk} \begin{pmatrix} -z_{ok} \\ y_{ok} \end{pmatrix} - \dot{\theta}_{Gk}^2 \begin{pmatrix} y_{ok} \\ z_{ok} \end{pmatrix} \quad (5.4)$$

Also required are expressions which define quantities involved in performing integration over the blade cross sectional area. Defining:

$$\iint_{A_T} \rho dA = m \quad ; \quad \iint_{A_T} \rho \eta_{ok} dA = mX_I \quad ; \quad \iint_{A_T} \rho \xi_{ok} dA = 0$$

$$\iint_{A_T} \rho \eta_{ok}^2 dA = I_{MB3} \quad ; \quad \iint_{A_T} \rho \xi_{ok}^2 dA = I_{MB2} \quad ; \quad \iint_{A_T} \rho \eta_{ok} \xi_{ok} dA = 0$$

from these, it follows that

$$\iint_{A_T} \rho y_{ok} dA = mX_I \cos \theta_{Gk} \quad ; \quad \iint_{A_T} \rho z_{ok} dA = mX_I \sin \theta_{Gk}$$

$$\iint_{A_T} \rho y_{ok}^2 dA = I_{MB3} \cos^2 \theta_{Gk} + I_{MB2} \sin^2 \theta_{Gk} \quad (5.5)$$

$$\iint_{A_T} \rho z_{ok}^2 dA = I_{MB3} \sin^2 \theta_{Gk} + I_{MB2} \cos^2 \theta_{Gk}$$

$$\iint_{A_T} \rho z_{ok} z_{ok} dA = (I_{MB3} - I_{MB2}) \sin \theta_{Gk} \cos \theta_{Gk}$$

In these integrals, ρ is the density of the material and A_T is the total cross-sectional area of the blade.

5.2 Equations of Motion for the Individual Blade

Dynamic equations of equilibrium for a blade are obtained using the Newtonian approach. The equations are obtained by combining the structural operator with the inertial, aerodynamic and structural damping loads. Since, the rigid, offset hinged, spring restrained model of the blade is used in this study, the various distributed loads are integrated over the blade length and then combined together to give the equation of motion. The various distributed loads obtained first, are described in the following sections.

5.2.1 Distributed Inertia Loads on the Blade

The distributed inertia loads on the k^{th} blade are obtained by first determining the acceleration at a general point 'P' on the blade. The loads per unit volume are found from D'Alembert's principle and they are integrated over the cross-section to give the distributed blade loads per unit length of the blade.

Acceleration at a point in the blade.

The absolute acceleration at a point 'P', viewed from a translating and rotating coordinate system with respect to an inertial frame, is given by

$$\bar{a}_{pk} = \ddot{\bar{R}}_o + \ddot{\bar{r}}_{pk} + 2\bar{\omega}_k \times \dot{\bar{r}}_{pk} + \dot{\bar{\omega}}_k \times \bar{r}_{pk} + \bar{\omega}_k \times (\bar{\omega}_k \times \bar{r}_{pk}) \quad (5.6)$$

where \bar{R}_o is the position vector of the origin of the moving coordinate system with respect to the inertial system.

\bar{r}_{pk} is the position vector of the point 'P' in the k^{th} blade from the origin of the moving reference system and $\bar{\omega}_k$ is the angular velocity of the moving coordinate system.

In the present rotor blade analysis, the inertial system is the R-system whose origin is fixed at the undeformed hub location and the the moving reference frame is the $2k$ -system whose origin moves and rotates with the blade.

The position vector of a point 'P' on the k^{th} blade is

$$\begin{aligned} \bar{r}_{p2k} = e \hat{e}_{x2k} + (x_k + u_k) \hat{e}_{x3k} + v_k \hat{e}_{y3k} + w_k \hat{e}_{z3k} + y_{ok} \hat{e}_{y4k} \\ + z_{ok} \hat{e}_{z4k} \end{aligned} \quad (5.7)$$

Transforming all the unit vectors to the 2k-system

$$\begin{aligned}
\bar{r}_{p2k} = & \hat{e}_{x2k} [(e + x_k + u_k) - \beta_p w_k + y_{ok} (-\zeta_k - \phi_k (\beta_p + \beta_k)) + \beta_p \beta_k \zeta_k] \\
& + z_{ok} (-\beta_p - \beta_k + \phi_k \zeta_k)] \\
& + \hat{e}_{y2k} [v_k + y_{ok} + z_{ok} (-\phi_k)] \\
& + \hat{e}_{z2k} [\beta_p (x_k + u_k) + w_k + y_{ok} (\phi_k - \zeta_k (\beta_p + \beta_k)) - \beta_p \beta_k \phi_k] \\
& + z_{ok} (1 - \beta_p \beta_k + \beta_p \phi_k \zeta_k)] \quad (5.8)
\end{aligned}$$

Applying the ordering scheme and substituting $w_k = x_k \beta_k$ and $v_k = x_k \zeta_k$ (based on rigid blade approximation), equation (5.8) becomes

$$\begin{aligned}
\bar{r}_{p2k} = & \hat{e}_{x2k} [e + x_k + y_{ok} (-\zeta_k - \phi_k (\beta_p + \beta_k)) + z_{ok} (-\beta_p - \beta_k + \phi_k \zeta_k)] \\
& + \hat{e}_{y2k} [x_k \zeta_k + y_{ok} + z_{ok} (-\phi_k)] \\
& + \hat{e}_{z2k} [\beta_k x_k + x_k \beta_p + y_{ok} (\phi_k - \zeta_k (\beta_p + \beta_k)) + z_{ok}] \quad (5.9)
\end{aligned}$$

Taking the first and second derivative of \bar{r}_{p2k} and applying the ordering scheme yields

$$\begin{aligned}
\dot{\bar{r}}_{p2k} = & \Omega \hat{e}_{x2k} [-\beta_p \dot{\beta}_k x_k + \dot{u}_k + y_{ok} \langle -\dot{\zeta}_k - \dot{\phi}_k (\beta_p + \beta_k) - \phi_k \dot{\beta}_k - \beta_k \dot{\theta}_{Gk} - \beta_p \dot{\theta}_{Gk} \rangle \\
& + z_{ok} \langle -\dot{\beta}_k + \dot{\phi}_k \zeta_k + \phi_k \dot{\zeta}_k + \zeta_k \dot{\theta}_{Gk} \rangle] \\
& + \Omega \hat{e}_{y2k} [x_k \dot{\zeta}_k + y_{ok} \langle -\phi_k \dot{\theta}_{Gk} \rangle + z_{ok} \langle -\dot{\phi}_k - \dot{\theta}_{Gk} \rangle] \\
& + \Omega \hat{e}_{z2k} [x_k \dot{\beta}_k + y_{ok} \langle \dot{\phi}_k - \dot{\zeta}_k (\beta_p + \beta_k) - \zeta_k \dot{\beta}_k + \dot{\theta}_{Gk} \rangle \\
& + z_{ok} \langle -\beta_p \dot{\beta}_k + \beta_p \dot{\phi}_k \zeta_k + \beta_p \phi_k \dot{\zeta}_k - \phi_k \dot{\theta}_{Gk} \\
& + \dot{\theta}_{Gk} (\beta_p + \beta_k) \rangle] \quad (5.10)
\end{aligned}$$

and

$$\begin{aligned}
\ddot{\mathbf{r}}_{p2k} = & \Omega^2 \hat{\mathbf{e}}_{x2k} [\ddot{u}_k - \beta_p \ddot{\beta}_k x_k + y_{ok} < -\ddot{\zeta}_k - \ddot{\phi}_k (\beta_p + \beta_k) - 2\dot{\phi}_k \dot{\beta}_k - \phi_k \ddot{\beta}_k \\
& - \ddot{\theta}_{Gk} (\beta_k + \beta_p) - 2\dot{\theta}_{Gk} \dot{\beta}_k > \\
& + z_{ok} < -\ddot{\beta}_k + \ddot{\phi}_k \zeta_k + 2\dot{\phi}_k \dot{\zeta}_k + \phi_k \ddot{\zeta}_k + 2\dot{\theta}_{Gk} \dot{\zeta}_k + \ddot{\theta}_{Gk} \zeta_k >] \\
& + \Omega^2 \hat{\mathbf{e}}_{y2k} [\ddot{\zeta}_k x_k + y_{ok} < -\dot{\theta}_{Gk}^2 - 2\dot{\theta}_{Gk} \dot{\phi}_k - \ddot{\theta}_{Gk} \phi_k > + z_{ok} < -\ddot{\theta}_{Gk} - \ddot{\phi}_k >] \\
& + \Omega^2 \hat{\mathbf{e}}_{z2k} [\beta_p \ddot{u}_k + \ddot{\beta}_k x_k + y_{ok} < \ddot{\phi}_k - \ddot{\zeta}_k (\beta_k + \beta_p) - 2\dot{\zeta}_k \dot{\beta}_k - \zeta_k \ddot{\beta}_k + \ddot{\theta}_{Gk} > \\
& + z_{ok} < -\beta_p \ddot{\beta}_k + \beta_p \ddot{\phi}_k \zeta_k + 2\beta_p \dot{\phi}_k \dot{\zeta}_k + \beta_p \phi_k \ddot{\zeta}_k \\
& - 2\dot{\theta}_{Gk} \dot{\phi}_k + 2\dot{\theta}_{Gk} \dot{\zeta}_k (\beta_p + \beta_k) + 2\dot{\theta}_{Gk} \dot{\beta}_k \zeta_k \\
& - \ddot{\theta}_{Gk} \phi_k + \ddot{\theta}_{Gk} \zeta_k (\beta_p + \beta_k) - \dot{\theta}_{Gk}^2 >] \tag{5.11}
\end{aligned}$$

The angular velocity of the k^{th} blade is

$$\bar{\omega}_k = \bar{\omega}_{0H} + \Omega \hat{\mathbf{e}}_{z1}$$

where $\bar{\omega}_{0H}$ is the angular velocity at the hub center 0_H due to the fuselage motion and it is given by equation (4.16). The angular velocity of the k^{th} blade in $2k$ system is (using equation (4.16) and noting that the R and S systems are parallel and inertial systems)

$$\begin{aligned}
\bar{\omega}_{2k} = & \Omega \hat{\mathbf{e}}_{x2k} [\cos\psi_k < \dot{\theta}_x - \theta_y \dot{\theta}_z > + \sin\psi_k < \dot{\theta}_y + \theta_x \dot{\theta}_z >] \\
& + \Omega \hat{\mathbf{e}}_{y2k} [\cos\psi_k < \dot{\theta}_y + \theta_x \dot{\theta}_z > + \sin\psi_k < -\dot{\theta}_x + \theta_y \dot{\theta}_z >] \\
& + \Omega \hat{\mathbf{e}}_{z2k} [1 + \dot{\theta}_z]
\end{aligned}$$

which can be written as

$$\bar{\omega}_{2k} = \Omega [\omega_x \hat{\mathbf{e}}_{x2k} + \omega_y \hat{\mathbf{e}}_{y2k} + (1 + \omega_z) \hat{\mathbf{e}}_{z2k}] \tag{5.12}$$

The angular acceleration $\dot{\omega}_{2k}$ is

$$\begin{aligned}\dot{\omega}_{2k} = & \Omega^2 \hat{e}_{x2k} [\cos\psi_k \langle \ddot{\theta}_x - \dot{\theta}_y \dot{\theta}_z - \theta_y \ddot{\theta}_z + \dot{\theta}_y + \theta_x \dot{\theta}_z \rangle + \\ & \sin\psi_k \langle \ddot{\theta}_y + \dot{\theta}_x \dot{\theta}_z + \theta_x \ddot{\theta}_z - \dot{\theta}_x + \theta_y \dot{\theta}_z \rangle] \\ & + \Omega^2 \hat{e}_{y2k} [\cos\psi_k \langle \ddot{\theta}_y + \dot{\theta}_x \dot{\theta}_z + \theta_x \ddot{\theta}_z - \dot{\theta}_x + \theta_y \dot{\theta}_z \rangle + \\ & \sin\psi_k \langle -\ddot{\theta}_x + \dot{\theta}_y \dot{\theta}_z + \theta_y \ddot{\theta}_z - \dot{\theta}_y - \theta_x \dot{\theta}_z \rangle] \\ & + \Omega^2 \hat{e}_{z2k} [\ddot{\theta}_z - \dot{\theta}_x \dot{\theta}_y - \theta_x \ddot{\theta}_y]\end{aligned}$$

which can be written as

$$\dot{\omega}_{2k} = \Omega^2 [\dot{\omega}_x \hat{e}_{x2k} + \dot{\omega}_y \hat{e}_{y2k} + \dot{\omega}_z \hat{e}_{z2k}] \quad (5.13)$$

In terms of dimensionless derivative in time, (ψ) , $(\dot{})$ is replaced by $\Omega^2(\dot{})$ in equation (5.6).

The acceleration is

$$\bar{a}_{p2k} = \Omega^2 [\bar{R}_o + \bar{r}_{p2k} + 2\bar{\omega}_{2k} \times \dot{\bar{r}}_{p2k} + \dot{\bar{\omega}}_{2k} \times \bar{r}_{p2k} + \bar{\omega}_{2k} \times (\bar{\omega}_{2k} \times \bar{r}_{p2k})] \quad (5.14)$$

In equation (5.14), all the quantities except the first term is relative to the 2k-system. The first term, i.e. the acceleration of the origin of the 2k-system is in the inertial system, as given by in equation (4.11). This contribution can be transformed into components parallel to 2k-system, as indicated below.

$$\begin{aligned}\ddot{\bar{R}}_o = & \Omega^2 \hat{e}_{x2k} [\cos\psi_k \langle \ddot{R}_x + \ddot{R}_y \theta_z - \ddot{R}_z \theta_y \rangle + \\ & \sin\psi_k \langle \ddot{R}_y - \ddot{R}_x \theta_z + \ddot{R}_z \theta_x \rangle] \\ & + \Omega^2 \hat{e}_{y2k} [\cos\psi_k \langle \ddot{R}_y - \ddot{R}_x \theta_z + \ddot{R}_z \theta_x \rangle + \\ & \sin\psi_k \langle -\ddot{R}_x - \ddot{R}_y \theta_z + \ddot{R}_z \theta_y \rangle] \\ & + \Omega^2 \hat{e}_{z2k} [\ddot{R}_z - \ddot{R}_y \theta_x + \ddot{R}_x \theta_y]\end{aligned} \quad (5.15)$$

Equation (5.15) has been obtained after applying the ordering scheme. The various terms in equations (5.12) and (5.15) contain the rigid body motion and the elastic deformation of the supporting structure. The various other terms in equation (5.14) are given below. These expressions are also obtained after applying the ordering scheme.

The Coriolis Term

$$\begin{aligned}
2\bar{\omega}_{2k} \times \dot{\bar{r}}_{p2k} = & 2\Omega^2 \hat{e}_{x2k} [\omega_y x_k \dot{\beta}_k - x_k \dot{\zeta}_k - \omega_z x_k \dot{\zeta}_k \\
& + y_{ok} < \omega_y (\dot{\phi}_k - \dot{\zeta}_k (\beta_p + \beta_k) - \zeta_k \dot{\beta}_k + \dot{\theta}_{Gk}) \\
& \qquad \qquad \qquad - (1 + \omega_z) (-\dot{\phi}_k \dot{\theta}_{Gk}) > \\
& + z_{ok} < - (1 + \omega_z) (-\dot{\phi}_k - \dot{\theta}_{Gk}) >] \\
& + 2\Omega^2 \hat{e}_{y2k} [\dot{u}_k - \beta_p \dot{\beta}_k x_k + \omega_z \dot{u}_k - \omega_z \beta_p \dot{\beta}_k x_k - \omega_x x_k \dot{\beta}_k \\
& + y_{ok} < (-\dot{\zeta}_k - \dot{\phi}_k (\beta_k + \beta_p) - \phi_k \dot{\beta}_k - \beta_k \dot{\theta}_{Gk} - \beta_p \dot{\theta}_{Gk} - \omega_z \dot{\zeta}_k) \\
& \qquad \qquad \qquad - \omega_x (\dot{\phi}_k + \dot{\theta}_{Gk}) > \\
& + z_{ok} < -\dot{\beta}_k + \dot{\phi}_k \zeta_k + \phi_k \dot{\zeta}_k + \zeta_k \dot{\theta}_{Gk} - \omega_z \dot{\beta}_k >] \\
& + 2\Omega^2 \hat{e}_{z2k} [\omega_x x_k \dot{\zeta}_k - \omega_y \dot{u}_k + \omega_y \beta_p \dot{\beta}_k x_k + \\
& + y_{ok} < -\omega_x \dot{\phi}_k \dot{\theta}_{Gk} - \omega_y (-\dot{\zeta}_k - \dot{\phi}_k (\beta_p + \beta_k) - \phi_k \dot{\beta}_k \\
& \qquad \qquad \qquad - \beta_k \dot{\theta}_{Gk} - \beta_p \dot{\theta}_{Gk}) > \\
& + z_{ok} < -\omega_x \dot{\phi}_k - \omega_x \dot{\theta}_{Gk} - \omega_y (-\dot{\beta}_k + \dot{\phi}_k \zeta_k + \phi_k \dot{\zeta}_k + \zeta_k \dot{\theta}_{Gk}) >]
\end{aligned}
\tag{5.16}$$

The Angular Acceleration Term

$$\begin{aligned}
 \dot{\bar{\omega}}_{2k} \times \bar{r}_{p2k} &= \Omega^2 \hat{e}_{x2k} [\dot{\omega}_y \beta_p x_k - \dot{\omega}_z x_k \zeta_k + \dot{\omega}_x x_k \zeta_k \\
 &\quad + y_{ok} \langle \dot{\omega}_y \phi_k - \dot{\omega}_z \rangle \\
 &\quad + z_{ok} \langle \dot{\omega}_y - \dot{\omega}_z (-\phi_k) \rangle] \\
 &+ \Omega^2 \hat{e}_{y2k} [\dot{\omega}_z e + \dot{\omega}_z x_k - \dot{\omega}_x \beta_p x_k - \dot{\omega}_x x_k \beta_k \\
 &\quad + y_{ok} \langle \dot{\omega}_z (-\zeta_k - \phi_k (\beta_p + \beta_k)) - \\
 &\quad - \dot{\omega}_x (\phi_k - \zeta_k (\beta_p + \beta_k)) \rangle \\
 &\quad + z_{ok} \langle \dot{\omega}_z (-\beta_p - \beta_k) - \dot{\omega}_x \rangle] \\
 &+ \Omega^2 \hat{e}_{z2k} [\dot{\omega}_x x_k \zeta_k - \dot{\omega}_y e - \dot{\omega}_y x_k + \\
 &\quad y_{ok} \langle \dot{\omega}_x - \dot{\omega}_y (-\zeta_k) \rangle \\
 &\quad + z_{ok} \langle \dot{\omega}_x (-\phi_k) - \dot{\omega}_y (-\beta_k - \beta_p + \phi_k \zeta_k) \rangle] \tag{5.17}
 \end{aligned}$$

The Centripetal Acceleration Term

$$\begin{aligned}
 \bar{\omega}_{2k} \times (\bar{\omega}_{2k} \times \bar{r}_{p2k}) &= \Omega^2 \hat{e}_{x2k} [-(x_k + x_k \omega_z + e + x_k \omega_z) \\
 &+ y_{ok} < -(-\zeta_k - \phi_k (\beta_k + \beta_p) - \omega_z \zeta_k) + \omega_x \phi_k \\
 & \qquad \qquad \qquad -\omega_z (-\zeta_k) > \\
 &+ z_{ok} < -(-\beta_k - \beta_p + \phi_k \zeta_k - \omega_z \beta_k - \omega_z \beta_p) + \omega_x \\
 & \qquad \qquad \qquad -\omega_z (-\beta_p - \beta_k) >] \\
 +\Omega^2 \hat{e}_{y2k} [&-x_k \zeta_k - \omega_z x_k \zeta_k + \omega_y \beta_p x_k + \omega_y x_k \beta_k \\
 & \qquad \qquad \qquad -\omega_z x_k \zeta_k \\
 + y_{ok} &< - (1 + 2\omega_z) > \\
 + z_{ok} &< \phi_k + \phi_k \omega_z + \omega_y + \phi_k \omega_z >] \\
 +\Omega^2 \hat{e}_{z2k} [&\omega_x x_k + \omega_x e + \omega_x \omega_z x_k + \omega_y x_k \zeta_k \\
 + y_{ok} &< \omega_y + \omega_y \omega_z - \omega_x \zeta_k > \\
 + z_{ok} &< \omega_x (-\beta_k - \beta_p + \phi_k \zeta_k - \omega_z \beta_k - \omega_z \beta_p) - \omega_x^2 \\
 &- \omega_y (\omega_y + \phi_k + \phi_k \omega_z) >] \qquad \qquad \qquad (5.18)
 \end{aligned}$$

Combining the various terms, i.e. equations (5.11), (5.15), (5.16), (5.17), (5.18) the three components of the acceleration can be written as

$$\begin{aligned}
a_{p_{x2k}} &= \Omega^2 \{-x_k - 2x_k \omega_z - e - 2x_k \dot{\zeta}_k + \cos\psi_k \ddot{R}_x + \sin\psi_k \ddot{R}_y \\
&+ y_{ok} [\zeta_k + \phi_k (\beta_p + \beta_k) + 2\omega_z \zeta_k + \omega_x \phi_k + \dot{\omega}_y \phi_k - \dot{\omega}_z \\
&\quad + 2\omega_y \dot{\phi}_k + 2\omega_y \dot{\theta}_{Gk} + 2\phi_k \dot{\theta}_{Gk} - \ddot{\zeta}_k \\
&\quad - \ddot{\phi}_k (\beta_k + \beta_p) - 2\dot{\phi}_k \dot{\beta}_k - \phi_k \ddot{\beta}_k - \ddot{\theta}_{Gk} \beta_p - 2\dot{\theta}_{Gk} \dot{\beta}_k - \ddot{\theta}_{Gk} \beta_k] \\
&+ z_{ok} [\beta_k + \beta_p - \phi_k \zeta_k + 2\omega_z \beta_k + 2\omega_z \beta_p + \omega_x + \dot{\omega}_y + \phi_k \dot{\omega}_z \\
&\quad + 2\dot{\phi}_k + 2\dot{\theta}_{Gk} + 2\omega_z (\dot{\phi}_k + \dot{\theta}_{Gk}) - \ddot{\beta}_k + \dot{\phi}_k \zeta_k + 2\dot{\phi}_k \dot{\zeta}_k \\
&\quad + \phi_k \ddot{\zeta}_k + 2\dot{\theta}_{Gk} \dot{\zeta}_k + \ddot{\theta}_{Gk} \zeta_k] \}
\end{aligned}$$

or in a more compact form

$$a_{p_{x2k}} = \Omega^2 [a_{p_{x2k}}^{(c)} + y_{ok} a_{p_{x2k}}^{(y)} + z_{ok} a_{p_{x2k}}^{(z)}] \quad (5.19)$$

The three terms correspond respectively to 1) the constant part of x-component of the acceleration over the cross-section of the blade at a distance x_k , 2) the part dependent on y_{ok} and 3) the term dependent on z_{ok} respectively. This separation facilitates integration of those terms over the cross-section of the blade to yield inertia forces. It also helps in identifying the orders of magnitude of various terms.

The y-component of the acceleration is

$$\begin{aligned}
a_{p_{y2k}} &= \Omega^2 \{-x_k \zeta_k - \omega_z x_k \zeta_k + \omega_y \beta_p x_k + \omega_y \beta_k x_k - \omega_z x_k \zeta_k + \dot{\omega}_z e \\
&\quad + \dot{\omega}_z x_k - \dot{\omega}_x \beta_p x_k - \dot{\omega}_x \beta_k x_k + \ddot{\zeta}_k x_k + \\
&\quad \cos\psi_k \ddot{R}_y + \sin\psi_k (-\ddot{R}_x) + 2\dot{u}_k - 2\beta_p \dot{\beta}_k x_k - 2\omega_x x_k \dot{\beta}_k
\end{aligned}$$

$$\begin{aligned}
& + y_{ok} [-1 - 2\dot{\omega}_z - 2\dot{\zeta}_k] \\
& + z_{ok} [\dot{\phi}_k + 2\dot{\phi}_k\dot{\omega}_z + \dot{\omega}_y - \beta_p\dot{\omega}_z - \beta_k\dot{\omega}_z - \dot{\omega}_x - 2\dot{\beta}_k + 2\dot{\phi}_k\zeta_k \\
& \quad + 2\dot{\phi}_k\dot{\zeta}_k + 2\ddot{\theta}_{Gk}\zeta_k - 2\dot{\omega}_z\dot{\beta}_k - \ddot{\theta}_{Gk} - \ddot{\phi}_k] \\
= \Omega^2 [a_{p_{y2k}}^{(c)} + y_{ok} a_{p_{y2k}}^{(y)} + z_{ok} a_{p_{y2k}}^{(z)}] \tag{5.20}
\end{aligned}$$

The z-component of the acceleration is

$$\begin{aligned}
a_{p_{z2k}} = \Omega^2 \{ & \omega_x x_k + \omega_x e + \omega_y x_k \zeta_k + \dot{\omega}_x x_k \zeta_k - \dot{\omega}_y e - \dot{\omega}_y x_k \\
& + 2\dot{\omega}_x x_k \dot{\zeta}_k + \ddot{R}_z + \ddot{\beta}_k x_k \\
& + y_{ok} [\ddot{\phi}_k - \ddot{\zeta}_k (\beta_p + \beta_k) - 2\dot{\zeta}_k \dot{\beta}_k - \zeta_k \ddot{\beta}_k + \ddot{\theta}_{Gk} + 2\dot{\omega}_y \dot{\zeta}_k + \dot{\omega}_x \\
& \quad + \dot{\omega}_y \zeta_k + \dot{\omega}_y - \dot{\omega}_x \zeta_k] \\
& + z_{ok} [-\ddot{\beta}_p \dot{\beta}_k + \beta_p \ddot{\phi}_k \zeta_k + 2\beta_p \dot{\phi}_k \dot{\zeta}_k + \beta_p \dot{\phi}_k \ddot{\zeta}_k - 2\ddot{\theta}_{Gk} \dot{\phi}_k \\
& \quad + 2\ddot{\theta}_{Gk} \dot{\zeta}_k (\beta_p + \beta_k) + 2\ddot{\theta}_{Gk} \dot{\beta}_k \zeta_k - \ddot{\theta}_{Gk} \phi_k + \ddot{\theta}_{Gk} \zeta_k (\beta_p + \beta_k) \\
& \quad - \ddot{\theta}_{Gk}^2 - 2\dot{\omega}_x \dot{\phi}_k - 2\dot{\omega}_x \dot{\theta}_{Gk} - 2\dot{\omega}_y (-\dot{\beta}_k + \dot{\phi}_k \zeta_k + \dot{\phi}_k \dot{\zeta}_k + \zeta_k \dot{\theta}_{Gk}) \\
& \quad - \dot{\omega}_x \dot{\phi}_k - \dot{\omega}_y (-\beta_p - \beta_k + \phi_k \zeta_k) + \\
& \quad + \dot{\omega}_x (-\beta_k - \beta_p + \phi_k \zeta_k) - \dot{\omega}_x^2 - \dot{\omega}_y (\dot{\omega}_y + \dot{\phi}_k)] \} \\
= \Omega^2 [a_{p_{z2k}}^{(c)} + y_{ok} a_{p_{z2k}}^{(y)} + z_{ok} a_{p_{z2k}}^{(z)}] \tag{5.21}
\end{aligned}$$

Transforming these acceleration components from 2k to 3k systems yields

$$\begin{aligned}
a_{p_{x3k}} &= \Omega^2 (a_{p_{x2k}} + \beta_p a_{p_{z2k}}) \\
&= \Omega^2 [a_{p_{x2k}}^{(c)} + \beta_p a_{p_{z2k}}^{(c)} + y_{ok} (a_{p_{x2k}}^{(y)} + \beta_p a_{p_{z2k}}^{(y)}) \\
&\quad + z_{ok} (a_{p_{x2k}}^{(z)} + \beta_p a_{p_{z2k}}^{(z)})] \\
a_{p_{y3k}} &= \Omega^2 a_{p_{y2k}} \\
&= \Omega^2 [a_{p_{y2k}}^{(c)} + y_{ok} a_{p_{y2k}}^{(y)} + z_{ok} a_{p_{y2k}}^{(z)}] \\
a_{p_{z3k}} &= \Omega^2 (-\beta_p a_{p_{x2k}} + a_{p_{z2k}}) \\
&= \Omega^2 [-\beta_p a_{p_{x2k}}^{(c)} + a_{p_{z2k}}^{(c)} + y_{ok} (-\beta_p a_{p_{x2k}}^{(y)} + a_{p_{z2k}}^{(y)}) \\
&\quad + z_{ok} (-\beta_p a_{p_{x2k}}^{(z)} + a_{p_{z2k}}^{(z)})]
\end{aligned} \tag{5.22}$$

Before evaluating the distributed inertia forces and moments, it is worth noting down the relative orders of magnitude of the leading terms in various acceleration components. They are

$$\begin{aligned}
a_{p_{x2k}}^{(c)} &= 0(1) \quad , \quad a_{p_{x2k}}^{(y)} = 0(\epsilon) \quad , \quad a_{p_{x2k}}^{(z)} = 0(\epsilon) \\
a_{p_{y2k}}^{(c)} &= 0(\epsilon) \quad , \quad a_{p_{y2k}}^{(y)} = 0(1) \quad , \quad a_{p_{y2k}}^{(z)} = 0(\epsilon) \\
a_{p_{z2k}}^{(c)} &= 0(\epsilon) \quad , \quad a_{p_{z2k}}^{(y)} = 0(\epsilon) \quad , \quad a_{p_{z2k}}^{(z)} = 0(\epsilon^2)
\end{aligned} \tag{5.23}$$

This information is useful in neglecting higher order terms even before evaluating the integrals to obtain inertia forces and moments.

Distributed Inertia Forces

The distributed inertia force per unit length is obtained from the D'Alembert's principle, for the k^{th} blade

$$\bar{p}_{Ik} = \iint_{A_T} -\rho \bar{a}_{pk} dA \quad (5.24)$$

where ρ is the material density of the blade.

Substituting the various components of the acceleration and using the cross-sectional parameters defined earlier, the distributed inertia forces are obtained, in the blade fixed 3k system. The acceleration components in the 3k system (from eq. (5.22)) are

$$\begin{aligned} a_{px3k} = & \Omega^2 \{ -x_{ok} - e - 2x_k \dot{\zeta}_k - 2x_k \dot{\theta}_z + \ddot{R}_x \cos\psi_k + \ddot{R}_y \sin\psi_k \\ & + y_{ok} [\zeta_k - \ddot{\zeta}_k + \phi_k (\beta_p + \beta_k) - \ddot{\phi}_k \beta_k + 2\dot{\theta}_z \zeta_k - \ddot{\theta}_z + 2\phi_k \dot{\theta}_{Gk} \\ & - 2\dot{\phi}_k \dot{\beta}_k - \phi_k \ddot{\beta}_k - 2\dot{\theta}_{Gk} \dot{\beta}_k - \ddot{\theta}_{Gk} \beta_k \\ & + \cos\psi_k \langle \phi_k \ddot{\theta}_y + 2\dot{\phi}_k \dot{\theta}_y + 2\dot{\theta}_{Gk} \dot{\theta}_y + \beta_p \ddot{\theta}_x + 2\beta_p \dot{\theta}_y \rangle \\ & + \sin\psi_k \langle -\phi_k \ddot{\theta}_x - 2\dot{\phi}_k \dot{\theta}_x - 2\dot{\theta}_{Gk} \dot{\theta}_x + \beta_p \ddot{\theta}_y - 2\beta_p \dot{\theta}_x \rangle] \\ & + z_{ok} [-\ddot{\beta}_k + \beta_k + \beta_p - \phi_k \zeta_k + 2\dot{\theta}_z (\beta_k + \beta_p) + 2\dot{\phi}_k + 2\dot{\theta}_{Gk} + \phi_k \ddot{\theta}_z \\ & + 2\dot{\theta}_z (\dot{\phi}_k + \dot{\theta}_{Gk}) + \dot{\phi}_k \zeta_k + 2\dot{\phi}_k \dot{\zeta}_k + \phi_k \ddot{\zeta}_k + 2\dot{\theta}_{Gk} \dot{\zeta}_k \\ & + \ddot{\theta}_{Gk} \zeta_k + \ddot{\theta}_y \cos\psi_k - \ddot{\theta}_x \sin\psi_k] \} \quad (5.25) \end{aligned}$$

$$\begin{aligned} a_{py3k} = & \Omega^2 \{ -x_k \zeta_k + x_k \ddot{\zeta}_k + 2\dot{u}_k - 2\beta_p \dot{\beta}_k x_k - 2\dot{\theta}_z x_k \zeta_k + \ddot{\theta}_z (x_k + e) \\ & + \cos\psi_k \langle -\ddot{\theta}_x (\beta_p + \beta_k) x_k + \ddot{R}_y - 2x_k \dot{\beta}_k \dot{\theta}_x \rangle \\ & + \sin\psi_k \langle -\ddot{\theta}_y (\beta_p + \beta_k) x_k - \ddot{R}_x - 2x_k \dot{\beta}_k \dot{\theta}_y \rangle \\ & + y_{ok} [-1 - 2\dot{\theta}_z - 2\dot{\zeta}_k] \\ & + z_{ok} [\phi_k - \ddot{\phi}_k + 2\phi_k \dot{\theta}_z - (\beta_p + \beta_k) \ddot{\theta}_z - 2\dot{\beta}_k + 2\dot{\phi}_k \zeta_k + 2\phi_k \dot{\zeta}_k \\ & + 2\zeta_k \dot{\theta}_{Gk} - 2\dot{\theta}_z \dot{\beta}_k - \ddot{\theta}_{Gk} - \ddot{\theta}_x \cos\psi_k - \ddot{\theta}_y \sin\psi_k] \} \quad (5.26) \end{aligned}$$

$$\begin{aligned}
a_{pz3k} = & \Omega^2 \{ x_k \ddot{\beta}_k + \ddot{R}_z + \beta_p (x_k + e + 2x_k \dot{\zeta}_k + 2x_k \dot{\theta}_z) \\
& + \cos\psi_k \langle (x_k + e) (-\ddot{\theta}_y + 2\dot{\theta}_x) + x_k \zeta_k (\ddot{\theta}_x + 2\dot{\theta}_y) + 2x_k \dot{\zeta}_k \dot{\theta}_x - \beta_p \ddot{R}_x \rangle \\
& + \sin\psi_k \langle (x_k + e) (\ddot{\theta}_x + 2\dot{\theta}_y) + x_k \zeta_k (\ddot{\theta}_y - 2\dot{\theta}_x) + 2x_k \dot{\zeta}_k \dot{\theta}_y - \beta_p \ddot{R}_y \rangle \\
& + y_{ok} [\ddot{\phi}_k - \ddot{\zeta}_k \beta_k - 2\dot{\zeta}_k \dot{\beta}_k - \zeta_k \ddot{\beta}_k + \ddot{\theta}_{Gk} - \beta_p \zeta_k + \beta_p \ddot{\theta}_z \\
& + \cos\psi_k \langle \ddot{\theta}_x + 2\dot{\theta}_y + \zeta_k (\ddot{\theta}_y - 2\dot{\theta}_x) + 2\dot{\zeta}_k \dot{\theta}_y \rangle \\
& + \sin\psi_k \langle \ddot{\theta}_y - 2\dot{\theta}_x - \zeta_k (\ddot{\theta}_x + 2\dot{\theta}_y) - 2\dot{\zeta}_k \dot{\theta}_x \rangle] \\
& + z_{ok} [-\beta_p \beta_k - \beta_p^2 + \beta_p \phi_k \zeta_k - 2\dot{\theta}_z \beta_p (\beta_p + \beta_k) - \beta_p \phi_k \ddot{\theta}_z - 2\beta_p \dot{\phi}_k \\
& - 2\beta_p \dot{\theta}_z (\dot{\phi}_k + \dot{\theta}_{Gk}) - 2\beta_p \dot{\theta}_{Gk} \dot{\zeta}_k \\
& - 2\dot{\theta}_{Gk} \dot{\phi}_k + 2\dot{\theta}_{Gk} \beta_k + 2\dot{\theta}_{Gk} \dot{\beta}_k \zeta_k - \ddot{\theta}_{Gk} \phi_k + \ddot{\theta}_{Gk} \zeta_k \beta_k \\
& - \dot{\theta}_{Gk}^2 - \dot{\theta}_x^2 - \dot{\theta}_y^2 \\
& + \cos\psi_k \langle -2\dot{\theta}_x (\dot{\phi}_k + \dot{\theta}_{Gk}) - 2\dot{\theta}_y (-\dot{\beta}_k + \dot{\phi}_k \zeta_k + \dot{\phi}_k \dot{\zeta}_k + \zeta_k \dot{\theta}_{Gk}) \\
& - \phi_k (\ddot{\theta}_x + 2\dot{\theta}_y) - (-\beta_k + \phi_k \zeta_k) (\ddot{\theta}_y - 2\dot{\theta}_x) - 2\beta_p \dot{\theta}_x \rangle \\
& + \sin\psi_k \langle -2\dot{\theta}_y (\dot{\phi}_k + \dot{\theta}_{Gk}) + 2\dot{\theta}_x (-\dot{\beta}_k + \dot{\phi}_k \zeta_k + \dot{\phi}_k \dot{\zeta}_k + \zeta_k \dot{\theta}_{Gk}) \\
& - \phi_k (\ddot{\theta}_y - 2\dot{\theta}_x) - (-\beta_k + \phi_k \zeta_k) (\ddot{\theta}_x + 2\dot{\theta}_y) - 2\beta_p \dot{\theta}_y \rangle] \} \quad (5.27)
\end{aligned}$$

Substituting equations (5.25 through 5.27) in equation (5.24) the distributed inertia loads are evaluated. The components of these loads are

$$p_{I_{x3k}} = m\Omega^2 [x_k + e + 2x_k \dot{\theta}_z + 2x_k \dot{\zeta}_k - \ddot{R}_x \cos\psi_k - \ddot{R}_y \sin\psi_k] \quad (5.28)$$

$$\begin{aligned}
P_{I_{y3k}} = m\Omega^2 [& x_k \zeta_k + 2x_k \zeta_k \dot{\theta}_z - (x_k + e) \ddot{\theta}_z - x_k \ddot{\zeta}_k - 2\dot{u}_k + 2x_k \dot{\beta}_k \dot{\beta}_p + x_I \cos\theta_{Gk} \\
& + \cos\psi_k \langle x_k \beta_p \ddot{\theta}_x + x_k \beta_k \ddot{\theta}_x + 2x_k \dot{\beta}_k \dot{\theta}_x - \ddot{R}_y \rangle \\
& + \sin\psi_k \langle x_k \beta_p \ddot{\theta}_y + x_k \beta_k \ddot{\theta}_y + 2x_k \dot{\beta}_k \dot{\theta}_y + \ddot{R}_x \rangle] \quad (5.29)
\end{aligned}$$

$$\begin{aligned}
P_{I_{z3k}} = m\Omega^2 [& -x_k \ddot{\beta}_k - \ddot{R}_z - \beta_p \langle x_k + e + 2x_k \dot{\theta}_z + 2x_k \dot{\zeta}_k \rangle \\
& + \cos\psi_k \langle \beta_p \ddot{R}_x - 2x_k \dot{\zeta}_k \dot{\theta}_x + (x_k + e) (\ddot{\theta}_y - 2\dot{\theta}_x) - x_k \zeta_k (\ddot{\theta}_x + 2\dot{\theta}_y) \rangle \\
& + \sin\psi_k \langle \beta_p \ddot{R}_y - 2x_k \dot{\zeta}_k \dot{\theta}_y - (x_k + e) (\ddot{\theta}_x + 2\dot{\theta}_y) - x_k \zeta_k (\ddot{\theta}_y - 2\dot{\theta}_x) \rangle] \quad (5.30)
\end{aligned}$$

Distributed Inertia Moment

The distributed moment per unit length for the k^{th} blade is also obtained by D'Alembert principle by taking the integral of the vector product given below.

$$\bar{q}_{Ik} = \iint_{A_T} [-\rho(y_{ok} \hat{e}_{y4k} + z_{ok} \hat{e}_{z4k}) \times \bar{a}_{pk}] dA \quad (5.31)$$

The moments are also evaluated in 3k system, and are given in component form below.

$$q_{I_{x3k}} = \iint_{A_T} -\rho [(y_{ok} - z_{ok} \phi_k) a_{pz3k} - (z_{ok} - y_{ok} \beta_k \zeta_k + y_{ok} \phi_k) a_{py3k}] dA$$

$$\begin{aligned}
q_{I_{y3k}} = \iint_{A_T} & -\rho [(z_{ok} - y_{ok} \beta_k \zeta_k + y_{ok} \phi_k) a_{px3k} \\
& - (-y_{ok} \zeta_k - y_{ok} \phi_k \beta_k - z_{ok} \beta_k + z_{ok} \phi_k \zeta_k) a_{pz3k}] dA
\end{aligned}$$

$$\begin{aligned}
q_{I_{z3k}} = \iint_{A_T} & -\rho [(-y_{ok} \zeta_k - y_{ok} \phi_k \beta_k - z_{ok} \beta_k + z_{ok} \phi_k \zeta_k) a_{py3k} \\
& - (y_{ok} - z_{ok} \phi_k) a_{px3k}] dA
\end{aligned}$$

Substituting for the acceleration components from equations (5.25) through (5.27) and making use of the integrals given in equation (5.5) the components of the distributed inertia moments (or torques per unit span) are evaluated. These expressions are given below.

$$\begin{aligned}
 q_{I_{x3k}} = & \Omega^2 \{ mx_I \cos \theta_{Gk} [-x_k \ddot{\beta}_k - \ddot{R}_z - \beta_p (x_k + e + 2x_k \dot{\zeta}_k + 2x_k \dot{\theta}_z) \\
 & - x_k \dot{\zeta}_k \phi_k + x_k \ddot{\zeta}_k \phi_k + x_k \phi_k \ddot{\theta}_z \\
 & + \cos \psi_k < (x_k + e) (\ddot{\theta}_y - 2\dot{\theta}_x) - x_k \dot{\zeta}_k (\ddot{\theta}_x + 2\dot{\theta}_y) \\
 & - 2x_k \dot{\zeta}_k \dot{\theta}_x + \beta_p \ddot{R}_x + \phi_k \ddot{R}_y > \\
 & + \sin \psi_k < - (x_k + e) (\ddot{\theta}_x + 2\dot{\theta}_y) - x_k \dot{\zeta}_k (\ddot{\theta}_y - 2\dot{\theta}_x) \\
 & - 2x_k \dot{\zeta}_k \dot{\theta}_y + \beta_p \ddot{R}_y - \phi_k \ddot{R}_x >] \\
 & + mx_I \sin \theta_{Gk} [-x_k \dot{\zeta}_k + x_k \ddot{\zeta}_k + 2\dot{u}_k - 2\beta_p \dot{\beta}_k x_k - 2\dot{\theta}_z x_k \dot{\zeta}_k \\
 & + \dot{\theta}_z (x_k + e) + \phi_k (\beta_p x_k + x_k \ddot{\beta}_k + \ddot{R}_z) \\
 & + \cos \psi_k < \ddot{R}_y - \ddot{\theta}_x (x_k \beta_k + x_k \beta_p) - 2x_k \dot{\beta}_k \dot{\theta}_x \\
 & + \phi_k x_k (-\ddot{\theta}_y + 2\dot{\theta}_x) > \\
 & + \sin \psi_k < - \ddot{R}_x - \ddot{\theta}_y (x_k \beta_p + x_k \beta_k) - 2x_k \dot{\beta}_k \dot{\theta}_y \\
 & + \phi_k x_k (\ddot{\theta}_x + 2\dot{\theta}_y) >] \\
 & + (I_{MB3} \cos^2 \theta_{Gk} + I_{MB2} \sin^2 \theta_{Gk}) [- \ddot{\phi}_k + \ddot{\zeta}_k \beta_k + 2\dot{\zeta}_k \dot{\beta}_k + \dot{\zeta}_k \ddot{\beta}_k \\
 & - \ddot{\theta}_{Gk} + \beta_p (\dot{\zeta}_k - \dot{\theta}_z) \\
 & + \phi_k (-1 - 2\dot{\theta}_z - 2\dot{\zeta}_k) + \beta_k \dot{\zeta}_k
 \end{aligned}$$

$$\begin{aligned}
& + \cos\psi_k < - (\ddot{\theta}_x + 2\dot{\theta}_y + \zeta_k (\ddot{\theta}_y - 2\dot{\theta}_x) + 2\dot{\zeta}_k \dot{\theta}_y) > \\
& + \sin\psi_k < - (\ddot{\theta}_y - 2\dot{\theta}_x - \zeta_k (\ddot{\theta}_x + 2\dot{\theta}_y) - 2\dot{\zeta}_k \dot{\theta}_x) >] \\
& + (I_{MB3} \sin^2 \theta_{Gk} + I_{MB2} \cos^2 \theta_{Gk}) [\phi_k - \ddot{\phi}_k + 2\dot{\phi}_k \dot{\theta}_z - \ddot{\theta}_z (\beta_p + \beta_k) - 2\dot{\beta}_k \\
& \quad + 2\dot{\phi}_k \dot{\zeta}_k + 2\dot{\phi}_k \dot{\zeta}_k + 2\dot{\zeta}_k \dot{\theta}_{Gk} \\
& \quad - 2\dot{\theta}_z \dot{\beta}_k - \ddot{\theta}_{Gk} - \ddot{\theta}_x \cos\psi_k - \ddot{\theta}_y \sin\psi_k] \\
& + (I_{MB3} - I_{MB2}) \sin\theta_{Gk} \cos\theta_{Gk} [-1 - 2\dot{\theta}_z - 2\dot{\zeta}_k] \quad (5.32) \\
q_{Iy3k} = & \Omega^2 \{ mx_I \cos\theta_{Gk} [\phi_k (x_k + e + 2x_k \dot{\zeta}_k + 2x_k \dot{\theta}_z) - \beta_k \zeta_k x_k \\
& \quad - \zeta_k (x_k \ddot{\beta}_k + \ddot{R}_z + \beta_p x_k) \\
& \quad + \cos\psi_k < -\phi_k \ddot{R}_z - \zeta_k (x_k + e) (-\ddot{\theta}_y + 2\dot{\theta}_x) > \\
& \quad + \sin\psi_k < -\phi_k \ddot{R}_y - \zeta_k (x_k + e) (\ddot{\theta}_x + 2\dot{\theta}_y) >] \\
& + mx_I \sin\theta_{Gk} [x_k + e + 2x_k \dot{\zeta}_k + 2x_k \dot{\theta}_z - \ddot{R}_x \cos\psi_k - \ddot{R}_y \sin\psi_k] \\
& + (I_{MB3} \cos^2 \theta_{Gk} + I_{MB2} \sin^2 \theta_{Gk}) [\phi_k \ddot{\zeta}_k - \ddot{\phi}_k \zeta_k - \dot{\phi}_k \dot{\zeta}_k + \dot{\phi}_k \ddot{\theta}_z \\
& \quad + (\beta_p + \beta_k) (\zeta_k^2 - \dot{\phi}_k^2) + \dot{\phi}_k (\dot{\phi}_k \ddot{\beta}_k + 2\dot{\phi}_k \dot{\beta}_k - 2\dot{\theta}_z \dot{\zeta}_k) \\
& \quad - \ddot{\theta}_z \zeta_k (\beta_p + \beta_k) - 2\dot{\theta}_{Gk} \dot{\phi}_k^2 - \ddot{\theta}_{Gk} \zeta_k \\
& \quad + 2\dot{\phi}_k \dot{\beta}_k \dot{\theta}_{Gk} + 2\dot{\zeta}_k \dot{\zeta}_k \dot{\beta}_k + \zeta_k^2 \ddot{\beta}_k \\
& + \cos\psi_k < -\zeta_k (\ddot{\theta}_x + 2\dot{\theta}_y + \zeta_k (\ddot{\theta}_y - 2\dot{\theta}_x) + 2\dot{\zeta}_k \dot{\theta}_y) \\
& \quad - \dot{\phi}_k \dot{\beta}_k (\ddot{\theta}_x + 2\dot{\theta}_y) >
\end{aligned}$$

$$\begin{aligned}
& -\phi_k (\phi_k \ddot{\theta}_y + 2\dot{\phi}_k \dot{\theta}_y + 2\dot{\theta}_{Gk} \dot{\theta}_y + \beta_p \ddot{\theta}_x + 2\dot{\beta}_p \dot{\theta}_y) \\
& + \sin\psi_k < -\zeta_k (\ddot{\theta}_y - 2\dot{\theta}_x - \zeta_k (\ddot{\theta}_x + 2\dot{\theta}_y)) - 2\dot{\zeta}_k \dot{\theta}_x \\
& \quad -\phi_k \beta_k (\ddot{\theta}_y - 2\dot{\theta}_x) \\
& - \phi_k (-\phi_k \ddot{\theta}_x - 2\dot{\phi}_k \dot{\theta}_x - 2\dot{\theta}_{Gk} \dot{\theta}_x + \beta_p \ddot{\theta}_y - 2\dot{\beta}_p \dot{\theta}_x) >] \\
& + (I_{MB3} \sin^2\theta_{Gk} + I_{MB2} \cos^2\theta_{Gk}) [\ddot{\beta}_k - \beta_k - \beta_p + \phi_k \zeta_k - 2\dot{\theta}_z (\beta_k + \beta_p) - \phi_k \ddot{\theta}_z \\
& \quad - 2\dot{\phi}_k - 2\dot{\theta}_{Gk} (1 + \zeta_k) - 2\dot{\theta}_z (\dot{\phi}_k + \dot{\theta}_{Gk}) \\
& \quad - \ddot{\phi}_k \zeta_k - 2\dot{\phi}_k \dot{\zeta}_k - \phi_k \ddot{\zeta}_k - \ddot{\theta}_{Gk} \zeta_k \\
& \quad - \ddot{\theta}_y \cos\psi_k + \ddot{\theta}_x \sin\psi_k] \\
& + (I_{MB3} - I_{MB2}) \sin\theta_{Gk} \cos\theta_{Gk} [-\zeta_k + \ddot{\zeta}_k - 2\dot{\phi}_k (\beta_k + \beta_p) - 2\dot{\theta}_z \zeta_k + \ddot{\theta}_z \\
& \quad - 4\dot{\phi}_k \dot{\theta}_{Gk} + 2\dot{\phi}_k \dot{\beta}_k + \phi_k \ddot{\beta}_k + 2\dot{\theta}_{Gk} \dot{\beta}_k \\
& \quad + \phi_k \ddot{\beta}_k - 2\dot{\phi}_k \dot{\phi}_k \\
& + \cos\psi_k < -2\dot{\phi}_k \ddot{\theta}_y - 2\dot{\phi}_k \dot{\theta}_y - 2\dot{\theta}_{Gk} \dot{\theta}_y - (\beta_p + \beta_k) (\ddot{\theta}_x + 2\dot{\theta}_y) > \\
& + \sin\psi_k < 2\dot{\phi}_k \ddot{\theta}_x + 2\dot{\phi}_k \dot{\theta}_x + 2\dot{\theta}_{Gk} \dot{\theta}_x - (\beta_p + \beta_k) (\ddot{\theta}_y - 2\dot{\theta}_x) >] \} (5.33)
\end{aligned}$$

$$\begin{aligned}
q_{I_{z3k}} &= \Omega^2 \{ mx_I \cos\theta_{Gk} (-x_k - e - 2x_k \dot{\zeta}_k - 2x_k \dot{\theta}_z + \ddot{R}_x \cos\psi_k + \ddot{R}_y \sin\psi_k) \\
& \quad + mx_I \sin\theta_{Gk} [\phi_k (x_k + e + 2x_k \dot{\zeta}_k + 2x_k \dot{\theta}_z) \\
& \quad + \beta_k (-x_k \zeta_k + x_k \ddot{\zeta}_k + \ddot{\theta}_z x_k)
\end{aligned}$$

$$\begin{aligned}
& + \cos\psi_k \langle -\dot{\phi}_k \ddot{R}_x + \beta_k \ddot{R}_y \rangle \\
& + \sin\psi_k \langle -\dot{\phi}_k \ddot{R}_y - \beta_k \ddot{R}_x \rangle] \\
& + (I_{MB3} \cos^2\theta_{Gk} + I_{MB2} \sin^2\theta_{Gk}) [-\ddot{\zeta}_k + \beta_p \dot{\phi}_k - \dot{\phi}_k \beta_k - \ddot{\theta}_z + 2\dot{\phi}_k \dot{\theta}_{Gk} \\
& \quad - 2\dot{\phi}_k \dot{\beta}_k - \dot{\phi}_k \ddot{\beta}_k - 2\dot{\theta}_{Gk} \beta_k - \ddot{\theta}_{Gk} \beta_k - 2\zeta_k \dot{\zeta}_k \\
& \quad + \cos\psi_k \langle \dot{\phi}_k \ddot{\theta}_y + 2\dot{\phi}_k \dot{\theta}_y + 2\dot{\theta}_{Gk} \dot{\theta}_y + \beta_p \ddot{\theta}_x + 2\beta_p \dot{\theta}_y \rangle \\
& \quad + \sin\psi_k \langle -\dot{\phi}_k \ddot{\theta}_x - 2\dot{\phi}_k \dot{\theta}_x - 2\dot{\theta}_{Gk} \dot{\theta}_x + \beta_p \ddot{\theta}_y - 2\beta_p \dot{\theta}_x \rangle] \\
& + (I_{MB3} \sin^2\theta_{Gk} + I_{MB2} \cos^2\theta_{Gk}) [-\dot{\phi}_k \langle -\ddot{\beta}_k + \beta_k + \beta_p - \dot{\phi}_k \zeta_k + 2\dot{\theta}_z (\beta_k + \beta_p) \\
& \quad + \dot{\phi}_k \ddot{\theta}_z + 2\dot{\phi}_k \dot{\theta}_z + 2\dot{\theta}_{Gk} \dot{\theta}_z + 2\dot{\theta}_z (\dot{\phi}_k + \dot{\theta}_{Gk}) + \dot{\phi}_k \zeta_k \\
& \quad + 2\dot{\phi}_k \dot{\zeta}_k + \dot{\phi}_k \zeta_k + 2\dot{\theta}_{Gk} \dot{\zeta}_k + \ddot{\theta}_{Gk} \zeta_k \rangle \\
& \quad + \beta_k \langle \dot{\phi}_k - \ddot{\phi}_k + 2\dot{\phi}_k \dot{\theta}_z - (\beta_p + \beta_k) \ddot{\theta}_z - 2\dot{\beta}_k \\
& \quad + 2\dot{\phi}_k \zeta_k + 2\dot{\phi}_k \dot{\zeta}_k + 2\zeta_k \dot{\theta}_{Gk} - 2\dot{\theta}_z \dot{\beta}_k - \ddot{\theta}_{Gk} \rangle \\
& \quad - \dot{\phi}_k \zeta_k \langle \dot{\phi}_k - \ddot{\phi}_k - 2\dot{\beta}_k - \ddot{\theta}_{Gk} \rangle \\
& \quad + \cos\psi_k \langle -\dot{\phi}_k \ddot{\theta}_y - \beta_k \ddot{\theta}_x + \dot{\phi}_k \zeta_k \ddot{\theta}_x \rangle \\
& \quad + \sin\psi_k \langle \dot{\phi}_k \ddot{\theta}_x - \beta_k \ddot{\theta}_y + \dot{\phi}_k \zeta_k \ddot{\theta}_y \rangle] \\
& + (I_{MB3} - I_{MB2}) \cos\theta_{Gk} \sin\theta_{Gk} [-\ddot{\beta}_k + \beta_p + 2\dot{\theta}_z \beta_p + 2\dot{\phi}_k \dot{\theta}_z + 2\dot{\theta}_{Gk} \dot{\theta}_z \\
& \quad + 2\dot{\theta}_z (\dot{\phi}_k + \dot{\theta}_{Gk}) + 2\dot{\phi}_k \dot{\zeta}_k + 2\dot{\theta}_{Gk} \dot{\zeta}_k \\
& \quad - 2\zeta_k \dot{\beta}_k - 2\zeta_k \dot{\beta}_k \\
& \quad + \cos\psi_k \langle \ddot{\theta}_y - \ddot{\theta}_x \zeta_k \rangle \\
& \quad + \sin\psi_k \langle -\ddot{\theta}_x - \ddot{\theta}_y \zeta_k \rangle] \tag{5.34}
\end{aligned}$$

5.2.2 Distributed Aerodynamic Loads

Greenberg [Ref. 10] has derived expressions for unsteady lift and moment on a two dimensional airfoil executing harmonic motion in a pulsating stream of incompressible fluid. This derivation is an extension of Theodorsen's unsteady aerodynamic theory [Ref. 11]. The lift and moment expressions consist of two contributions. The first contribution is due to circulatory flow and the second one is due to noncirculatory flow. Greenberg has assumed that the circulatory lift and noncirculatory lift are acting in the same direction, i.e. normal to the resultant flow. However other researchers using this theory have introduced their interpretation. For example Hodges and Ormiston [Ref. 12]. assumed that the circulatory lift acts normal to the resultant flow and the noncirculatory lift acts normal to the blade chord. An examination of the alternative mathematical expressions for the unsteady lift indicates that assuming the noncirculatory part of the lift to be perpendicular to the blade chord is somewhat more convenient. In this study it is assumed that the circulatory lift acts normal to the resultant flow and the noncirculatory lift acts normal to the blade chord, for mathematical convenience.

The lift and moment expression as given by Greenberg are

$$L_C = 2\pi\rho_A bV [V_o \alpha + \sigma V_o \dot{\alpha} c(k_v) e^{i\omega_v t} + [b(\frac{1}{2} - a) \dot{\beta} + V_o \beta] c(k_\beta) + \dot{h} c(k_h) + \sigma V_o \dot{\beta} c(k_{v+\beta}) e^{i\omega_v t}] \quad (5.35)$$

$$L_{NC} = \pi\rho_A b^2 [\ddot{h} + V\dot{\beta} + V(\alpha + \beta) - ab\ddot{\beta}] \quad (5.36)$$

where L_C is the circulatory lift

L_{NC} is noncirculatory lift

Referring to Fig. 10

- h is the vertical displacement of the axis of rotation (positive downward)
- α is the constant part of the angle of attack
- β is the time varying part of the angle of attack
- V_o is the constant part of the stream velocity

$\sigma v_o e^{i\omega_v t}$ is the varying part of the stream velocity

$$v = v_o (1 + \sigma e^{i\omega_v t})$$

ba is the position of the torsion axis (axis of rotation of the airfoil) measured from the center of the airfoil section.

The total moment due to both circulatory and noncirculatory parts is

$$\begin{aligned} M = \pi \rho_A b^2 [& ba \ddot{h} + \dot{v} ba(\alpha + \beta) - vb \left(\frac{1}{2} - a \right) \dot{\beta} - b^2 \left(\frac{1}{8} + a^2 \right) \ddot{\beta}] \\ & + 2\pi \rho_A vb^2 \left(a + \frac{1}{2} \right) \{ v_o \alpha + \sigma v_o \alpha c(k_v) e^{i\omega_v t} \\ & + [b \left(\frac{1}{2} - a \right) \dot{\beta} + v_o \beta] c(k_\beta) + \dot{h} c(k_h) \\ & + \sigma v_o \beta c(k_{v+\beta}) e^{i\omega_v t} \} \end{aligned} \quad (5.37)$$

where M is the pitching moment about the axis of rotation (positive nose up).

For low frequency oscillations of the rotor blades, the reduced frequency, k, is low and one can introduce the assumption that the Theodorsen's lift deficiency function c(k) is unity. This is equivalent to the quasisteady assumption. Furthermore from Figs. 3 and 10 one has

$$ba = -b + x_A + \frac{b}{2} = x_A - \frac{b}{2} \quad (5.38)$$

Substituting for 'ba' from equation (5.38) and replacing c(k) by unity, the lift and moment equations become

$$L_C = 2\pi \rho_A b v [h + v(\alpha + \beta) + (b - x_A) \dot{\beta}] \quad (5.39)$$

$$L_{NC} = \pi \rho_A b^2 [\ddot{h} + v \ddot{\beta} + \dot{v}(\alpha + \beta) - (x_A - \frac{b}{2}) \ddot{\beta}] \quad (5.40)$$

$$\begin{aligned} M = \pi \rho_A b^2 \{ & (x_A - \frac{b}{2}) [\ddot{h} + \dot{v}(\alpha + \beta) + v \ddot{\beta} - (x_A - \frac{b}{2}) \ddot{\beta}] - v \frac{b}{2} \dot{\beta} - \frac{b^2}{8} \ddot{\beta} \} \\ & + 2\pi \rho_A b v x_A [h + v(\alpha + \beta) + (b - x_A) \dot{\beta}] \end{aligned} \quad (5.41)$$

Equations (5.39) - (5.41) can be rewritten in a modified form by replacing the quantity 2π by the incompressible lift curve slope 'a', also replacing $\alpha + \beta$ by $\bar{\alpha}$, which represents the total effective angle of attack, where α represents the constant part thus $\dot{\bar{\alpha}} = \dot{\beta}$; $\ddot{\bar{\alpha}} = \ddot{\beta}$ and

$$L_C = \rho_A a b v [\dot{h} + v\bar{\alpha} + (b - x_A) \dot{\bar{\alpha}}] \quad (5.42)$$

$$L_{NC} = \frac{1}{2} \rho_A a b^2 [\ddot{h} + v\dot{\bar{\alpha}} + \dot{v}\bar{\alpha} - (x_A - \frac{b}{2}) \ddot{\bar{\alpha}}] \quad (5.43)$$

$$M = \frac{1}{2} \rho_A a b^2 \left\{ (x_A - \frac{b}{2}) [\ddot{h} + v\dot{\bar{\alpha}} + \dot{v}\bar{\alpha} - (x_A - \frac{b}{2}) \ddot{\bar{\alpha}}] - \frac{vb}{2} \dot{\bar{\alpha}} - \frac{b^2}{8} \ddot{\bar{\alpha}} \right\} \\ + a \rho_A b v x_A [\dot{h} + v\bar{\alpha} + (b - x_A) \dot{\bar{\alpha}}] \quad (5.44)$$

Next the various velocity components, relative to the oscillating rotor blade have to be identified. Let \bar{v}_{Ak} be the free stream velocity and \bar{v}_{Eck} be the velocity at any point on the elastic axis of the k^{th} blade due to its oscillation, the net air flow velocity for the k^{th} blade is then

$$\bar{v}_k = \bar{v}_{Ak} - \bar{v}_{Eck} \quad (5.45)$$

For a rotor blade in forward flight with constant velocity, the free stream velocity is

$$\bar{v}_{Ak} = v_F \cos\alpha_R \hat{e}_{Rx} - (v_F \sin\alpha_R + v_k) \hat{e}_{Rz} \quad (5.46)$$

where v_F is the forward velocity of the model

α_R is the angle of forward tilt of the rotor plane

v_k is the induced velocity

Equation (5.46) can be written in terms of nondimensional quantities μ and λ_k where μ is the advance ratio = $v_F \cos\alpha_R / \Omega R$ and λ_k is the inflow ratio = $(v_F \sin\alpha_R + v_k) / \Omega R$. Hence

$$\bar{v}_{Ak} = \Omega R (\mu \hat{e}_{Rx} - \lambda_k \hat{e}_{Rz}) \quad (5.47)$$

This velocity can be written in terms of components along the $2k$ -system

$$\bar{v}_{A2k} = \Omega R \{ [\cos\psi_k \langle \mu + \lambda_k \theta_y \rangle + \sin\psi_k \langle \mu(\theta_y \theta_x - \theta_z) - \lambda_k \theta_x \rangle] \hat{e}_{x2k} \\ + [\cos\psi_k \langle \mu(\theta_y \theta_x - \theta_z) - \lambda_k \theta_x \rangle + \sin\psi_k \langle -\mu - \lambda_k \theta_y \rangle] \hat{e}_{y2k}$$

$$+ [\mu(\dot{\theta}_y + \dot{\theta}_z \theta_x) - \lambda_k] \hat{e}_{z2k} \} \quad (5.48)$$

The velocity at any point on the elastic axis due to blade deformation is

$$\bar{v}_{Eck} = \dot{R}_{OH} + \dot{r}_{pk} + \bar{\omega}_k \times \bar{r}_{pk} \quad (5.49)$$

where \dot{R}_{OH} is the velocity of the hub center

\dot{r}_{pk} is the velocity of the point 'p' on the elastic axis of the blade as seen in the rotating reference frame

$\bar{\omega}_k$ is the angular velocity of the rotating reference frame

$$\text{and } \bar{r}_{pk} = e \hat{e}_{x2k} + (x_k + u_k) \hat{e}_{x3k} + w_k \hat{e}_{z3k} + v_k \hat{e}_{y3k} \quad (5.50)$$

The various terms in equation (5.49), in 2k system, are

$$\dot{r}_{pk} = \Omega \{ (-\beta_p \dot{\beta}_k x_k + \dot{u}_k) \hat{e}_{x2k} + x_k \dot{\zeta}_k \hat{e}_{y2k} + x_k \dot{\beta}_k \hat{e}_{z2k} \} \quad (5.51)$$

(Based on rigid blade assumption, i.e. $w_k = x_k \beta_k$ and $v_k = x_k \zeta_k$) and

$$\begin{aligned} \dot{R}_{OH} = \Omega \{ & \hat{e}_{x2k} [\cos \psi_k \langle \dot{R}_x + \dot{R}_y \theta_z - \dot{R}_z \theta_y \rangle + \\ & \sin \psi_k \langle \dot{R}_y - \dot{R}_x \theta_z + \dot{R}_z \theta_y \rangle] \\ & + \hat{e}_{y2k} [\cos \psi_k \langle \dot{R}_y - \dot{R}_x \theta_z + \dot{R}_z \theta_x \rangle + \\ & \sin \psi_c \langle -\dot{R}_x - \dot{R}_y \theta_z + \dot{R}_z \theta_y \rangle] \\ & + \hat{e}_{z2k} [\dot{R}_z - \dot{R}_y \theta_x + \dot{R}_x \theta_y] \} \end{aligned} \quad (5.52)$$

and

$$\begin{aligned} \bar{\omega}_k \times \bar{r}_{p2k} = \Omega \{ & \hat{e}_{x2k} [-x_k \dot{\zeta}_k - x_k \dot{\zeta}_k \theta_z + \cos \psi_k \langle \dot{\theta}_y (\beta_p x_k + \beta_k x_k) \rangle \\ & + \sin \psi_k \langle -\dot{\theta}_x (\beta_p x_k + \beta_k x_k) \rangle] \\ & + \hat{e}_{y2k} [x_k + e + x_k \dot{\theta}_z] \end{aligned}$$

$$\begin{aligned}
& + \hat{e}_{z2k} [x_k \zeta_k < \cos\psi_k \dot{\theta}_x + \sin\psi_k \dot{\theta}_y > \\
& - (x_k + e) < \cos\psi_k (\dot{\theta}_y + \dot{\theta}_x \dot{\theta}_z) + \sin\psi_k (-\dot{\theta}_x + \dot{\theta}_y \dot{\theta}_z) >] \} \\
\end{aligned} \tag{5.53}$$

Combining equations (5.51) - (5.53)

$$\begin{aligned}
\bar{v}_{EC2k} = & \Omega \hat{e}_{x2k} \{ -x_k \zeta_k - x_k \zeta_k \dot{\theta}_z + \dot{u}_k - \beta_p \beta_k x_k \\
& + \cos\psi_k < \dot{R}_x + \dot{R}_y \dot{\theta}_z - \dot{R}_z \dot{\theta}_y + \dot{\theta}_y (x_k \beta_p + x_k \beta_k) > \\
& + \sin\psi_k < \dot{R}_y - \dot{R}_x \dot{\theta}_z + \dot{R}_z \dot{\theta}_x - \dot{\theta}_x (x_k \beta_p + x_k \beta_k) > \\
& + \Omega \hat{e}_{y2k} \{ x_k \zeta_k + x_k + e + x_k \dot{\theta}_z + \cos\psi_k < \dot{R}_y - \dot{R}_x \dot{\theta}_z + \dot{R}_z \dot{\theta}_x > \\
& + \sin\psi_k < -\dot{R}_x - \dot{R}_y \dot{\theta}_z + \dot{R}_z \dot{\theta}_y > \} \\
& + \Omega \hat{e}_{z2k} \{ x_k \beta_k + \dot{R}_z - \dot{R}_y \dot{\theta}_x + \dot{R}_x \dot{\theta}_y \\
& - (x_k + e) < \cos\psi_k (\dot{\theta}_y + \dot{\theta}_x \dot{\theta}_z) + \sin\psi_k (-\dot{\theta}_x + \dot{\theta}_y \dot{\theta}_z) > \\
& + x_k \zeta_k < \cos\psi_k \dot{\theta}_x + \sin\psi_k \dot{\theta}_y > \} \tag{5.54}
\end{aligned}$$

Substituting equations (5.48) and (5.54) in equation (5.45) and applying the ordering scheme yields

$$\begin{aligned}
-\bar{v}_{2k} = & \Omega \{ \hat{e}_{x2k} [x_k \zeta_k (1 + \dot{\theta}_z) - \dot{u}_k + \beta_p \beta_k x_k + \cos\psi_k < \mu R - \dot{R}_x > \\
& + \sin\psi_k < -\mu R \dot{\theta}_z - \lambda_k R \dot{\theta}_x - \dot{R}_y + x_k \dot{\theta}_k (\beta_p + \beta_k) >] \\
& + \hat{e}_{y2k} [-x_k - e - x_k \dot{\theta}_z - x_k \zeta_k + \cos\psi_k < -\mu R \dot{\theta}_z - \dot{R}_y - \lambda_k R \dot{\theta}_x > \\
& + \sin\psi_k < -\mu R + \dot{R}_x >]
\end{aligned}$$

$$\begin{aligned}
& + \hat{e}_{z2k} [- x_k \dot{\beta}_k - \lambda_k \dot{R} - \dot{R}_z + \mu R \dot{\theta}_y - \cos \psi_k \langle x_k \dot{\zeta}_k \dot{\theta}_x - (x_k + e) \dot{\theta}_y \rangle \\
& \quad - \sin \psi_k \langle x_k \dot{\zeta}_k \dot{\theta}_y + (x_k + e) \dot{\theta}_x \rangle] \quad (5.55)
\end{aligned}$$

This velocity is again transformed into components along the 5k system where 5k system is defined as the one whose origin is fixed in the deformed blade elastic axis and rotated from 4k system by removing the elastic torsional rotation. In the 5k system, the velocity components are

$$\begin{aligned}
V_{x5k} = \Omega \{ & - e \dot{\zeta}_k - \dot{u}_k - x_k \dot{\beta}_k \dot{\beta}_k + (\beta_p + \beta_k) (-\lambda_k \dot{R} - \dot{R}_z + \mu R \dot{\theta}_y) \\
& - x_k \dot{\zeta}_k \dot{\zeta}_k + \cos \psi_k \langle \mu R - \dot{R}_x \rangle \\
& + \sin \psi_k \langle - \mu R \dot{\zeta}_k - \mu R \dot{\theta}_z - \dot{R}_y - \lambda_k R \dot{\theta}_x + \dot{R}_x \dot{\zeta}_k \rangle \} \quad (5.56)
\end{aligned}$$

$$\begin{aligned}
V_{y5k} = \Omega [& - x_k \dot{e} - x_k \dot{\zeta}_k - x_k \dot{\theta}_z + \cos \psi_k \langle - \mu R \dot{\theta}_z - \dot{R}_y - \mu R \dot{\zeta}_k \rangle \\
& + \sin \psi_k \langle - \mu R + \dot{R}_x \rangle] \quad (5.57)
\end{aligned}$$

$$\begin{aligned}
V_{z5k} = \Omega [& - x_k \dot{\beta}_k - \lambda_k \dot{R} + \mu R \dot{\theta}_y - \dot{R}_z - x_k \dot{\zeta}_k (\beta_k + \beta_p) \\
& - \cos \psi_k \langle x_k \dot{\zeta}_k \dot{\theta}_x - (x_k + e) \dot{\theta}_y + (\beta_p + \beta_k) (\mu R - \dot{R}_x) \rangle \\
& - \sin \psi_k \langle x_k \dot{\zeta}_k \dot{\theta}_y + (x_k + e) \dot{\theta}_x + (\beta_p + \beta_k) (-\mu R \dot{\theta}_z - \dot{R}_y) \rangle] \quad (5.58)
\end{aligned}$$

For the evaluation of the unsteady aerodynamic forces and moments, the various velocity terms in equations (5.42) - (5.44) have to be identified.

Figure 11 shows that

$$v = -v_{y5k} \quad ; \quad h = v_{z5k} \quad \text{and} \quad \bar{\alpha} = \theta_{Gk} + \phi_k \quad (5.59)$$

Substituting these in the lift and moment expressions, the loads per unit length on the k^{th} blade becomes

$$L_{Ck} = \rho_A a b v_{y5k} [- v_{z5k} + v_{y5k} (\theta_{Gk} + \phi_k) - (b - x_A) (\dot{\theta}_{Gk} + \dot{\phi}_k) \Omega] \quad (5.60)$$

$$L_{NCK} = \frac{1}{2} \rho_A a b^2 [\dot{v}_{z5k} - \dot{v}_{y5k} (\theta_{Gk} + \phi_k) - v_{y5k} (\dot{\theta}_{Gk} + \dot{\phi}_k) \Omega - (x_A - \frac{b}{2}) (\ddot{\theta}_{Gk} + \ddot{\phi}_k) \Omega^2] \quad (5.61)$$

$$M_k = \rho_A a b v_{y5k} x_A [-v_{z5k} + v_{y5k} (\theta_{Gk} + \phi_k) - (b - x_A) (\dot{\theta}_{Gk} + \dot{\phi}_k) \Omega] + \frac{a}{2} \rho_A b^2 [(x_A - \frac{b}{2}) [\dot{v}_{z5k} - \dot{v}_{y5k} (\theta_{Gk} + \phi_k) - v_{y5k} (\dot{\theta}_{Gk} + \dot{\phi}_k) \Omega - (x_A - \frac{b}{2}) (\ddot{\theta}_{Gk} + \ddot{\phi}_k) \Omega^2] + \frac{b}{2} v_{y5k} (\dot{\theta}_{Gk} + \dot{\phi}_k) \Omega - \frac{b^2}{8} (\ddot{\theta}_{Gk} + \ddot{\phi}_k) \Omega^2] \quad (5.62)$$

The drag force D_k is

$$D_k = \rho_A a b \left(\frac{c_{do}}{a} \right) [v_{y5k}^2 + v_{z5k}^2] \quad (5.63)$$

The inflow angle ϕ_{ik} is

$$\phi_{ik} = \tan^{-1} \left(\frac{v_{z5k}}{v_{y5k}} \right) \quad (5.64)$$

According to the assumption made previously, the circulatory lift acts normal to the resultant flow and the noncirculatory lift acts normal to the blade chord. Resolving the lift and drag forces along the 5k system (Fig. 11), the force components per unit length are

$$P_{A_{y5k}} = -\rho_A a b v_{y5k} [-v_{z5k} + v_{y5k} (\theta_{Gk} + \phi_k) - (b - x_A) (\dot{\theta}_{Gk} + \dot{\phi}_k) \Omega] \sin \phi_{ik} - \frac{1}{2} \rho_A a b^2 [\dot{v}_{z5k} - v_{y5k} (\dot{\theta}_{Gk} + \dot{\phi}_k) \Omega - \dot{v}_{y5k} (\theta_{Gk} + \phi_k) - (x_A - \frac{b}{2}) (\ddot{\theta}_{Gk} + \ddot{\phi}_k) \Omega^2] \sin (\theta_{Gk} + \phi_k) - \rho_A a b \left(\frac{c_{do}}{a} \right) [v_{y5k}^2 + v_{z5k}^2] \cos \phi_{ik} \quad (5.65)$$

$$P_{A_{z5k}} = \rho_A a b v_{y5k} [-v_{z5k} + v_{y5k} (\theta_{Gk} + \phi_k) - (b - x_A) (\dot{\theta}_{Gk} + \dot{\phi}_k) \Omega] \cos \phi_{ik} + \frac{1}{2} \rho_A a b^2 [\dot{v}_{z5k} - v_{y5k} (\dot{\theta}_{Gk} + \dot{\phi}_k) \Omega - \dot{v}_{y5k} (\theta_{Gk} + \phi_k) - (x_A - \frac{b}{2}) (\ddot{\theta}_{Gk} + \ddot{\phi}_k) \Omega^2] \cos (\theta_{Gk} + \phi_k)$$

$$- \rho_A a b \left(\frac{c_{do}}{a} \right) [v_{y5k}^2 + v_{z5k}^2] \sin\phi_{ik} \quad (5.66)$$

and the torsional moment, per unit length is

$$\begin{aligned} q_{A_{x5k}} &= \rho_A a b v_{y5k} x_A [-v_{z5k} + v_{y5k} (\theta_{Gk} + \phi_k) - (b-x_A) (\dot{\theta}_{Gk} + \dot{\phi}_k) \Omega] \\ &+ \frac{1}{2} \rho_A a b^2 \left[(x_A - \frac{b}{2}) [\dot{v}_{z5k} - \dot{v}_{y5k} (\theta_{Gk} + \phi_k) - v_{y5k} (\dot{\theta}_{Gk} + \dot{\phi}_k) \Omega] \right. \\ &\quad \left. - (x_A - \frac{b}{2}) (\ddot{\theta}_{Gk} + \ddot{\phi}_k) \Omega^2 \right] \\ &+ \frac{b}{2} v_{y5k} (\dot{\theta}_{Gk} + \dot{\phi}_k) \Omega - \frac{b^2}{8} (\ddot{\theta}_{Gk} + \ddot{\phi}_k) \Omega^2 \end{aligned} \quad (5.67)$$

Assuming that angle ϕ_{ik} is small, the following approximations are made.

$$\sin\phi_{ik} \approx \phi_{ik} = v_{z5k}/v_{y5k}$$

$$\cos\phi_{ik} \approx 1$$

And also

$$\sin(\theta_{Gk} + \phi_k) = \sin\theta_{Gk} + \phi_k \cos\theta_{Gk}$$

$$\cos(\theta_{Gk} + \phi_k) = \cos\theta_{Gk} - \phi_k \sin\theta_{Gk}$$

Note that v_{z5k}/v_{y5k} is $O(\epsilon)$, ϕ_{ik} is $O(\epsilon)$, θ_{Gk} is $O(\epsilon^{1/2})$ and $(\frac{c_{do}}{a})$ is $O(\epsilon^{3/2})$.

Using these approximations, the force components per unit length become

$$\begin{aligned} p_{A_{y5k}} &= \rho_A a b v_{z5k} [v_{z5k} - v_{y5k} (\theta_{Gk} + \phi_k) + (b-x_A) (\dot{\theta}_{Gk} + \dot{\phi}_k) \Omega] \\ &- \rho_A a b \left(\frac{c_{do}}{a} \right) v_{y5k}^2 \\ &- \frac{1}{2} \rho_A a b^2 [\dot{v}_{z5k} - v_{y5k} (\dot{\theta}_{Gk} + \dot{\phi}_k) \Omega - \dot{v}_{y5k} (\theta_{Gk} + \phi_k)] \\ &- (x_A - \frac{b}{2}) (\ddot{\theta}_{Gk} + \ddot{\phi}_k) \Omega^2 [\sin\theta_{Gk} + \phi_k \cos\theta_{Gk}] \end{aligned} \quad (5.68)$$

$$\begin{aligned}
P_{A_{z5k}} &= \rho_A a b v_{y5k} [-v_{z5k} + v_{y5k} (\theta_{Gk} + \phi_k) - (b - x_A) (\dot{\theta}_{Gk} + \dot{\phi}_k) \Omega] \\
&+ \frac{1}{2} \rho_A a b^2 [\dot{v}_{z5k} - v_{y5k} (\dot{\theta}_{Gk} + \dot{\phi}_k) \Omega - \dot{v}_{y5k} (\theta_{Gk} + \phi_k) \\
&- (x_A - \frac{b}{2}) (\ddot{\theta}_{Gk} + \ddot{\phi}_k) \Omega^2] [\cos \theta_{Gk} - \phi_k \sin \theta_{Gk}] \quad (5.69)
\end{aligned}$$

Where the appropriate velocity components have to be substituted in these equations. These velocity components are given in equations (5.56)-(5.58). The aerodynamic forces per unit length of the blade, in component form are

$$\begin{aligned}
P_{A_{y5k}} &= \rho_A a b \Omega^2 \left\{ -\frac{c_{do}}{a} [x_k^2 (1 + 2\dot{\zeta}_k + 2\dot{\theta}_z) + 2x_k e] \right. \\
&- x_k^2 [\dot{\beta}_k < \theta_{Gk} + \phi_k - \dot{\beta}_k + \dot{\zeta}_k (\theta_{Gk} + \phi_k) \\
&- \zeta_k (\beta_p + \beta_k) + \dot{\theta}_z \theta_{Gk} > \\
&+ \zeta_k (\beta_p + \beta_k) < \theta_{Gk} + \phi_k - \dot{\beta}_k >] \\
&- x_k [\dot{\beta}_k < -\lambda_k R + e(\theta_{Gk} + \phi_k) + \mu R \theta_y - \dot{R}_z > \\
&+ \lambda_k R < \theta_{Gk} + \phi_k - \dot{\beta}_k + \dot{\zeta}_k (\theta_{Gk} + \phi_k) - \zeta_k (\beta_p + \beta_k) + \dot{\theta}_z \theta_{Gk} > \\
&+ (-\mu R \theta_y + \dot{R}_z) < \theta_{Gk} + \phi_k - \dot{\beta}_k + \dot{\zeta}_k \theta_{Gk} > \\
&+ \zeta_k (\beta_p + \beta_k) < -\lambda_k R > + \dot{\beta}_k b (\dot{\theta}_{Gk} + \dot{\phi}_k)] \\
&- \lambda_k R < -\lambda_k R + e(\theta_{Gk} + \phi_k) + \mu R \theta_y - \dot{R}_z > \\
&+ (\mu R \theta_y - \dot{R}_z) < -\lambda_k R + e \theta_{Gk} + \mu R \theta_y - \dot{R}_z > \\
&- \lambda_k R b (\dot{\theta}_{Gk} + \dot{\phi}_k)
\end{aligned}$$

$$\begin{aligned}
& - \cos\psi_k \left[2 \frac{c_{do}}{a} [x_k (\mu R \zeta_k + \mu R \dot{\theta}_z + \dot{R}_y)] \right. \\
& - x_k^2 [-\dot{\beta}_k \dot{\theta}_y - \zeta_k \dot{\theta}_x \dot{\theta}_{Gk} + \dot{\theta}_y (\dot{\theta}_{Gk} + \dot{\phi}_k - \dot{\beta}_k) + \zeta_k \dot{\theta}_{Gk} \dot{\theta}_y] \\
& - x_k [\dot{\beta}_k < \mu R (\beta_p + \beta_k) + \theta_{Gk} (-\mu R \zeta_k - \mu R \dot{\theta}_z - \dot{R}_y) - \phi_k \mu R \zeta_k > \\
& - \dot{\theta}_y < \lambda_k R - \mu R \dot{\theta}_y + \dot{R}_z > \\
& + \zeta_k (\beta_p + \beta_k) < \mu R (\beta_p + \beta_k) \\
& - \theta_{Gk} < -e \dot{\theta}_y + (\beta_p + \beta_k) (\mu R - \dot{R}_x) \\
& + (-\dot{\phi}_k + \dot{\beta}_k) < \mu R (\beta_p + \beta_k) > \\
& - \lambda_k R \dot{\theta}_y - \zeta_k (\dot{\theta}_{Gk} + \dot{\phi}_k) \mu R (\beta_p + \beta_k) \\
& + \dot{\theta}_y < e \theta_{Gk} + \mu R \dot{\theta}_y - \dot{R}_z > \\
& + (\dot{\theta}_z \theta_{Gk} - \zeta_k (\beta_p + \beta_k)) < -\mu R (\beta_p + \beta_k) >] \\
& - \lambda_k R < \mu R (\beta_p + \beta_k) + \theta_{Gk} (-\mu R \zeta_k - \mu R \dot{\theta}_z - \dot{R}_y) - \mu R \zeta_k \phi_k > \\
& + (\mu R \dot{\theta}_y - \dot{R}_z) < \mu R (\beta_p + \beta_k) - \mu R \zeta_k \theta_{Gk} > \\
& - \lambda_k R < \mu R (\beta_p + \beta_k) > \\
& + [e(\dot{\theta}_{Gk} + \dot{\phi}_k) + \mu R \dot{\theta}_y - \dot{R}_z] < \mu R (\beta_p + \beta_k) > \\
& + \mu R (\beta_p + \beta_k) b (\dot{\theta}_{Gk} + \dot{\phi}_k)]
\end{aligned}$$

$$\begin{aligned}
& - \sin\psi_k \left[\frac{2c_{do}}{a} [x_k < \mu R (1 + \zeta_k + \dot{\theta}_z) - \dot{R}_x > + e \mu R] \right. \\
& - x_k^2 [\dot{\beta}_k \dot{\theta}_x - \theta_{Gk} \zeta_k \dot{\theta}_y - \dot{\theta}_x (\dot{\theta}_{Gk} + \dot{\phi}_k - \dot{\beta}_k) - \theta_{Gk} \zeta_k \dot{\theta}_x]
\end{aligned}$$

$$\begin{aligned}
& - x_k \left[\dot{\beta}_k < -\mu R (\theta_{Gk} + \phi_k) + \theta_{Gk} \dot{R}_x > \right. \\
& + \dot{\theta}_x < \lambda_k R - \mu R \theta_y + \dot{R}_z > \\
& + \zeta_k (\beta_p + \beta_k) < -\mu R (\theta_{Gk} + \phi_k) > \\
& - \theta_{Gk} < e \dot{\theta}_x + (\beta_p + \beta_k) (-\mu R \theta_z - \dot{R}_y) > \\
& + \lambda_k R \dot{\theta}_x - \dot{\theta}_x < e \theta_{Gk} + \mu R \theta_y - \dot{R}_z >] \\
& - \lambda_k R < -\mu R (\theta_{Gk} + \phi_k) + \theta_{Gk} \dot{R}_x > \\
& + (\mu R \theta_y - \dot{R}_z) < -\mu R (\theta_{Gk} + \phi_k) >] \\
& + \cos \psi_k \sin \psi_k \left[-2 \frac{c_{do}}{a} [\mu R (\mu R \zeta_k + \mu R \theta_z + \dot{R}_y)] \right. \\
& - x_k^2 [2 \dot{\theta}_y \dot{\theta}_x] \\
& - x_k [-\dot{\theta}_x < 2\mu R (\beta_p + \beta_k) - 2\mu R \zeta_k \theta_{Gk} > \\
& + \dot{\theta}_y < -\mu R (\theta_{Gk} + \phi_k) >] \\
& + \mu R \theta_{Gk} e \dot{\theta}_y - \mu R (\beta_p + \beta_k) < \mu R \theta_{Gk} + \mu R \phi_k > \\
& + 2 \mu R \theta_{Gk} \dot{R}_x (\beta_p + \beta_k)] \\
& + \cos^2 \psi_k [x_k^2 \dot{\theta}_y^2 - x_k [2 \dot{\theta}_y (\beta_p + \beta_k) \mu R - \mu R \zeta_k \theta_{Gk} \dot{\theta}_y] + \mu R^2 (\beta_p + \beta_k)^2 \\
& + \mu R (\beta_p + \beta_k) < -\mu R \zeta_k (\theta_{Gk} + \phi_k) + \theta_{Gk} (-\dot{R}_y - \mu R \theta_z) >] \\
& + \sin^2 \psi_k [x_k^2 \dot{\theta}_x^2 + x_k [-\mu R \theta_{Gk} (\dot{\theta}_x + \zeta_k \dot{\theta}_y) - \mu R \phi_k \dot{\theta}_x] \\
& - \mu R \theta_{Gk} < e \dot{\theta}_x + (\beta_p + \beta_k) (-\mu R \theta_z - \dot{R}_y) > \\
& - \frac{c_{do}}{a} < \mu^2 R^2 - 2\mu R \dot{R}_x >]]
\end{aligned}$$

$$\begin{aligned}
& - \frac{1}{2} \rho_A a b^2 \Omega^2 \{ - x_k [(\ddot{\beta}_k - (\dot{\theta}_{Gk} + \dot{\phi}_k)) \langle \sin\theta_{Gk} + \phi_k \cos\theta_{Gk} \rangle - \ddot{\zeta}_k \theta_{Gk} \sin\theta_{Gk}] \\
& \quad + \sin\theta_{Gk} (\mu R \ddot{\theta}_y - \ddot{R}_z) - \cos\psi_k [- x_k (\ddot{\theta}_y - \dot{\theta}_x) \sin\theta_{Gk} \\
& \quad + [\mu R \ddot{\beta}_k - \mu R (\theta_{Gk} + \phi)] \langle \sin\theta_{Gk} + \phi_k \cos\theta_{Gk} \rangle \\
& \quad \quad \quad - \mu R \dot{\zeta}_k \theta_{Gk} \sin\theta_{Gk}] \\
& \quad - \sin\psi_k [x_k (\ddot{\theta}_x + \dot{\theta}_y) \sin\theta_{Gk} - [\mu R (\beta_p + \beta_k) \\
& \quad + \mu R (\dot{\theta}_{Gk} + \dot{\phi}_k)] \langle \sin\theta_{Gk} + \phi_k \cos\theta_{Gk} \rangle + \mu R \dot{\zeta}_k \theta_{Gk} \sin\theta_{Gk}] \} \\
& \hspace{15em} (5.70)
\end{aligned}$$

$$\begin{aligned}
P_{A_{z5k}} & = \rho_A a b \Omega^2 \{ x_k^2 [\theta_{Gk} + \phi_k - \dot{\beta}_k + \dot{\zeta}_k (\theta_{Gk} + \phi_k) - \zeta_k (\beta_p + \beta_k) + \dot{\theta}_z \theta_{Gk} \\
& \quad + \dot{\zeta}_k \langle \theta_{Gk} + \phi_k - \dot{\beta}_k \rangle + \dot{\theta}_z \theta_{Gk}] \\
& \quad + x_k [-\lambda_k R + e(\theta_{Gk} + \phi_k) + \mu R \dot{\theta}_y - \dot{R}_z - \lambda_k R \dot{\zeta}_k \\
& \quad + e \langle \theta_{Gk} + \phi_k - \dot{\beta}_k \rangle + b(\dot{\theta}_{Gk} + \dot{\phi}_k)] - e \lambda_k R \\
& \quad \quad \quad - \cos\psi_k [- x_k^2 \dot{\theta}_y \\
& \quad + x_k [\mu R (\beta_p + \beta_k) + \theta_{Gk} (-\mu R \dot{\zeta}_k - \dot{R}_y - \mu R \dot{\theta}_z) - \mu R \dot{\zeta}_k \phi_k \\
& \quad + \dot{\zeta}_k \langle \mu R (\beta_p + \beta_k) \rangle + \theta_{Gk} \langle -\mu R \dot{\zeta}_k - \dot{R}_y - \mu R \dot{\theta}_z \rangle \\
& \quad + (\phi_k - \dot{\beta}_k) \langle -\mu R \dot{\zeta}_k \rangle + e \mu R (\beta_p + \beta_k) + \lambda_k R \mu R \dot{\zeta}_k] \\
& \quad \quad \quad - \sin\psi_k [x_k^2 \dot{\theta}_x \\
& \quad + x_k [-\mu R (\theta_{Gk} + \phi_k) + \dot{R}_x \theta_{Gk} - \mu R (\theta_{Gk} + \phi_k) \dot{\zeta}_k \\
& \quad \quad \quad - \mu R \dot{\theta}_z \theta_{Gk} - \mu R \langle \theta_{Gk} + \phi_k - \dot{\beta}_k \rangle + \dot{R}_x \theta_{Gk}
\end{aligned}$$

$$\begin{aligned}
& - \mu R < \dot{\zeta}_k (\theta_{Gk} + \phi_k) - \zeta_k (\beta_p + \beta_k) + \dot{\theta}_z \theta_{Gk} >] \\
& + e < - \mu R (\theta_{Gk} + \phi_k) > + \lambda_k R \mu R \\
& - \mu R < e (\theta_{Gk} + \phi_k) + \mu R \dot{\theta}_y - \dot{R}_z > \\
& - \mu R b (\dot{\theta}_{Gk} + \dot{\phi}_k)] \\
& + \cos \psi_k \sin \psi_k [x_k \mu R \dot{\theta}_y \\
& - \mu R < \mu R (\beta_p + \beta_k) + \theta_{Gk} (-\mu R \dot{\zeta}_k - \dot{R}_y - \mu R \dot{\theta}_z) - \mu R \zeta_k \dot{\phi}_k > \\
& + \mu R \zeta_k < \mu R (\theta_{Gk} + \phi_k) > - \mu R \dot{\theta}_{Gk} < - \mu R \dot{\theta}_z - \dot{R}_y >] \\
& + \cos^2 \psi_k [- \mu^2 R^2 \zeta_k (\beta_p + \beta_k)] + \sin^2 \psi_k [- x_k \mu R \dot{\theta}_x \\
& - \mu R < - \mu R (\theta_{Gk} + \phi_k) + \dot{R}_x \theta_{Gk} > - \mu R \dot{R}_x \theta_{Gk}]] \\
& + \frac{1}{2} \rho_A a b^2 \Omega^2 \{ - x_k < \ddot{\beta}_k - (\dot{\theta}_{Gk} + \dot{\phi}_k) > \\
& - \cos \psi_k < \mu R \ddot{\beta}_k - \mu R (\theta_{Gk} + \phi_k) > \\
& - \sin \psi_k < - \mu R (\beta_p + \beta_k) - \mu R (\dot{\theta}_{Gk} + \dot{\phi}_k) > \} \cos \theta_{Gk}
\end{aligned} \tag{5.71}$$

It can be seen from the expressions for the aerodynamic forces that the contribution due to $(\ddot{\theta}_{Gk} + \ddot{\phi}_k)$ associated with equation (5.40) is absent because of ordering scheme. Equation (5.71) can be written as

$$p_{A_{z5k}} = p_{A_{z5k}}^{(1)} + p_{A_{z5k}}^{(2)} \cos \theta_{Gk} \tag{5.72}$$

where $p_{A_{z5k}}^{(1)}$ represents the circulatory term and $p_{A_{z5k}}^{(2)}$ represents the non-circulatory term.

The aerodynamic moment per unit length can be written as

$$\begin{aligned}
q_{A_{x5k}} &= x_A p_{A_{z5k}}^{(1)} + (x_A - \frac{b}{2}) p_{A_{z5k}}^{(2)} - \frac{b^2}{8} (\ddot{\theta}_{Gk} + \ddot{\phi}_k) \Omega^2 \frac{1}{2} \rho_A a b^2 \\
&\quad + \frac{1}{2} \rho_A a b^2 \frac{b}{2} (\dot{\theta}_{Gk} + \dot{\phi}_k) \Omega^2 \{-x_k - e - \cos\psi_k \mu R \zeta_k - \sin\psi_k \mu R\}
\end{aligned}
\tag{5.73}$$

$$\begin{aligned}
&= \rho_A a b \Omega^2 x_A \{ x_k^2 [\dot{\theta}_{Gk} + \dot{\phi}_k - \dot{\beta}_k + \dot{\zeta}_k (\dot{\theta}_{Gk} + \dot{\phi}_k) - \dot{\zeta}_k (\dot{\beta}_p + \dot{\beta}_k) \\
&\quad + \dot{\theta}_z \dot{\theta}_{Gk} + \dot{\zeta}_k \langle \dot{\theta}_{Gk} + \dot{\phi}_k - \dot{\beta}_k \rangle + \dot{\theta}_z \dot{\theta}_{Gk}] \\
&\quad + x_k [-\lambda_k R + e(\dot{\theta}_{Gk} + \dot{\phi}_k) + \mu R \dot{\theta}_y - \dot{R}_z - \lambda_k R \dot{\zeta}_k \\
&\quad + e \langle \dot{\theta}_{Gk} + \dot{\phi}_k - \dot{\beta}_k \rangle + b (\dot{\theta}_{Gk} + \dot{\phi}_k)] - e \lambda_k R \\
&\quad - \cos\psi_k [-x_k^2 \dot{\theta}_y + x_k [\mu R (\dot{\beta}_p + \dot{\beta}_k) \\
&\quad + \dot{\theta}_{Gk} (-\mu R \dot{\zeta}_k - \dot{R}_y - \mu R \dot{\theta}_z) - \mu R \dot{\zeta}_k \dot{\phi}_k \\
&\quad + \dot{\zeta}_k \langle \mu R (\dot{\beta}_p + \dot{\beta}_k) \rangle + \dot{\theta}_{Gk} \langle -\mu R \dot{\zeta}_k - \dot{R}_y - \mu R \dot{\theta}_z \rangle \\
&\quad + (\dot{\phi}_k - \dot{\beta}_k) (-\mu R \dot{\zeta}_k)] + e \mu R (\dot{\beta}_p + \dot{\beta}_k) + \lambda_k R \mu R \dot{\zeta}_k] \\
&\quad - \sin\psi_k [x_k^2 \dot{\theta}_x + x_k [-\mu R (\dot{\theta}_{Gk} + \dot{\phi}_k) \\
&\quad + \dot{R}_x \dot{\theta}_{Gk} - \mu R (\dot{\theta}_{Gk} + \dot{\phi}_k) \dot{\zeta}_k - \mu R \dot{\theta}_z \dot{\theta}_{Gk} \\
&\quad - \mu R \langle \dot{\theta}_{Gk} + \dot{\phi}_k - \dot{\beta}_k \rangle + \dot{R}_x \dot{\theta}_{Gk} \\
&\quad - \mu R \langle \dot{\zeta}_k (\dot{\theta}_{Gk} + \dot{\phi}_k) - \dot{\zeta}_k (\dot{\beta}_p + \dot{\beta}_k) + \dot{\theta}_z \dot{\theta}_{Gk} \rangle] \\
&\quad + e \langle -\mu R (\dot{\theta}_{Gk} + \dot{\phi}_k) \rangle + \lambda_k R \mu R \\
&\quad - \mu R \langle e (\dot{\theta}_{Gk} + \dot{\phi}_k) + \mu R \dot{\theta}_y - \dot{R}_z \rangle - \mu R b (\dot{\theta}_{Gk} + \dot{\phi}_k)]
\end{aligned}$$

$$\begin{aligned}
& + \cos\psi_k \sin\psi_k [x_k \mu R \dot{\theta}_y - \mu R \langle \mu R (\beta_p + \beta_k) + \theta_{Gk} (-\mu R \zeta_k - \dot{R}_y - \mu R \dot{\theta}_z) - \mu R \zeta_k \phi_k \rangle \\
& + \mu R \zeta_k \langle \mu R (\theta_{Gk} + \phi_k) \rangle - \mu R \theta_{Gk} \langle -\mu R \dot{\theta}_z - \dot{R}_y \rangle] \\
& + \cos^2\psi_k [-\mu^2 R^2 \zeta_k (\beta_p + \beta_k)] + \sin^2\psi_k [-x_k \mu R \dot{\theta}_x \\
& \quad - \mu R \langle -\mu R (\theta_{Gk} + \phi_k) + \dot{R}_x \theta_{Gk} \rangle - \mu R \dot{R}_x \theta_{Gk}] \\
& + \frac{1}{2} \rho_A a b^2 \Omega^2 (x_A - \frac{b}{2}) \{ -x_k \langle \ddot{\beta}_k - (\ddot{\theta}_{Gk} + \ddot{\phi}_k) \rangle \\
& \quad - \cos\psi_k \langle \mu R \ddot{\beta}_k - \mu R (\theta_{Gk} + \phi_k) \rangle \\
& \quad - \sin\psi_k \langle -\mu R (\beta_p + \beta_k) - \mu R (\dot{\theta}_{Gk} + \dot{\phi}_k) \rangle \} \\
& \quad - \frac{1}{2} \rho_A a b^2 \frac{b^2}{8} \Omega^2 (\ddot{\theta}_{Gk} + \ddot{\phi}_k) \\
& + \frac{1}{2} \rho_A a b^2 \frac{b}{2} \Omega^2 (\dot{\theta}_{Gk} + \dot{\phi}_k) \{ -x_k - e - \cos\psi_k \mu R \zeta_k - \sin\psi_k \mu R \}
\end{aligned} \tag{5.74}$$

These aerodynamic force and moment expressions are transformed into components in 3k system because the blade dynamic equations of motion are written in 3k system. The appropriate components are

$$P_{A_{x3k}} = -\zeta_k P_{A_{y5k}} - \beta_k P_{A_{z5k}} \tag{5.75}$$

$$P_{A_{y3k}} = P_{A_{y5k}} \tag{5.76}$$

$$P_{A_{z3k}} = P_{A_{z5k}} - \beta_k \zeta_k P_{A_{y5k}} \approx P_{A_{z5k}} \tag{5.77}$$

$$q_{A_{x3k}} = q_{A_{x5k}} \tag{5.78}$$

$$q_{A_{y3k}} = \zeta_k q_{A_{x5k}} \tag{5.79}$$

$$q_{A_{z3k}} = \beta_k q_{A_{x5k}} \tag{5.80}$$

5.2.3 Distributed Structural Damping Loads

The structural damping incorporated in this analysis is of a viscous equivalent type. The damping forces per unit span of the blade for flap, lag and torsion are respectively given as

$$\text{Flap} \quad p_{D_{z3k}} = \Omega x_k \dot{\beta}_k g_{SF} \quad (5.81)$$

$$\text{Lead-lag} \quad p_{D_{y3k}} = -\Omega x_k \dot{\zeta}_k g_{SL} \quad (5.82)$$

$$\text{Torsion} \quad q_{D_{x3k}} = -\Omega \dot{\phi}_k g_{ST} \quad (5.83)$$

No attempt is made to eliminate these terms by considering the ordering schemes since these terms serve the purpose of determining the effect of damping on stability.

5.2.4 Rotor Blade Equations

In this section, the individual blade equations of motion are presented. For the rigid, offset hinged, spring restrained blade model used in this study, the distributed inertia, aerodynamic and structural damping loads are integrated over the length of the blade and moment equilibrium at the spring restrained hinge is enforced. The loads due to inertia, aerodynamic and damping, integrated over the blade span, are given in the following sections. Finally the blade equations are obtained by enforcing moment equilibrium at the root of the blade.

Inertia Loads

The forces and moments at the blade root due to the inertia forces are

$$\bar{P}_{I3k} = \int_0^{R-e} \bar{p}_{I3k} dx_k \quad (5.84)$$

$$\bar{Q}_{I3k} = \int_0^{R-e} (\bar{q}_{I3k} + \bar{r}_{p3k} \times \bar{p}_{I3k}) dx_k \quad (5.85)$$

where \bar{p}_{I3k} are the distributed inertia force on the k^{th} blade and \bar{q}_{I3k} is the distributed inertia moment about the elastic axis. These quantities are derived in previous sections of this report.

Recall that the position vector of any point "p" on the deformed elastic axis of the blade is given by

$$\bar{r}_{p3k} = (x_k + u_k) \hat{e}_{x3k} + x_k \zeta_k \hat{e}_{y3k} + x_k \beta_k \hat{e}_{z3k} \quad (5.86)$$

and u_k is the axial displacement primarily due to geometric shortening

$$\begin{aligned} u_k &= -\frac{1}{2} \int_0^{x_k} (\zeta_k^2 + \beta_k^2) dx_k \\ &= -\frac{1}{2} x_k (\zeta_k^2 + \beta_k^2) \end{aligned} \quad (5.87)$$

and

$$\dot{u}_k = -x_k (\dot{\zeta}_k \zeta_k + \dot{\beta}_k \beta_k) \quad (5.88)$$

It is assumed that the inflow is constant over the disk and the pretwist of the blade is zero. Hence in integrations over the blade span λ and θ_{Gk} remain constants. Mass per unit length of the blade is also assumed to be constant.

The components of the inertia forces at the root of the blade in 3k system are

$$\begin{aligned} P_{I_{x3k}} &= m\Omega^2 \left[\frac{(R-e)^2}{2} + (R-e)e + \frac{(R-e)^2}{2} \dot{\theta}_z + \frac{(R-e)^2}{2} 2\dot{\zeta}_k \right. \\ &\quad \left. - (R-e) \langle \ddot{R}_x \cos\psi_k + \ddot{R}_y \sin\psi_k \rangle \right] \end{aligned} \quad (5.89)$$

$$\begin{aligned} P_{I_{y3k}} &= m\Omega^2 \left[\frac{(R-e)^2}{2} \langle \zeta_k + 2\zeta_k \dot{\theta}_z - \ddot{\theta}_z - \dot{\zeta}_k + 2\dot{\beta}_k \beta_k \rangle \right. \\ &\quad \left. - (R-e) e \ddot{\theta}_z + 2 \frac{(R-e)^2}{2} [\dot{\zeta}_k \dot{\zeta}_k + \dot{\beta}_k \dot{\beta}_k] + (R-e) X_I \cos\theta_{Gk} \right. \\ &\quad \left. + \cos\psi_k \langle \frac{(R-e)^2}{2} \langle \beta_p \ddot{\theta}_x + \beta_k \ddot{\theta}_x + 2\dot{\beta}_k \dot{\theta}_x \rangle - (R-e) \ddot{R}_y \rangle \right. \\ &\quad \left. + \sin\psi_k \langle \frac{(R-e)^2}{2} \langle \beta_p \ddot{\theta}_y + \beta_k \ddot{\theta}_y + 2\dot{\beta}_k \dot{\theta}_y \rangle + (R-e) \ddot{R}_x \rangle \right] \end{aligned} \quad (5.90)$$

$$\begin{aligned}
P_{I_{z3k}} &= m\Omega^2 \left[-\frac{(R-e)^2}{2} \ddot{\beta}_k - (R-e) \ddot{R}_z - \beta_p < \frac{(R-e)^2}{2} (1+2\dot{\theta}_z + 2\dot{\zeta}_k) + (R-e)e > \right. \\
&\quad + \cos\psi_k < (R-e) [\beta_p \ddot{R}_x + e(\ddot{\theta}_y - 2\dot{\theta}_x)] \\
&\quad - \frac{(R-e)^2}{2} [2\dot{\zeta}_k \dot{\theta}_x - (\ddot{\theta}_y - 2\dot{\theta}_x) + \zeta_k (\ddot{\theta}_x + 2\dot{\theta}_y)] \\
&\quad + \sin\psi_k < (R-e) [\beta_p \ddot{R}_y - e(\ddot{\theta}_x + 2\dot{\theta}_y)] \\
&\quad \left. - \frac{(R-e)^2}{2} [2\dot{\zeta}_k \dot{\theta}_y + (\ddot{\theta}_x + 2\dot{\theta}_y) + \zeta_k (\ddot{\theta}_y - 2\dot{\theta}_x)] > \right] \\
&\hspace{15em} (5.91)
\end{aligned}$$

The components of the inertia moments, after applying the ordering scheme, are

$$\begin{aligned}
Q_{I_{x3k}} &= \int_0^{R-e} (q_{I_{x3k}} + x_k \zeta_k P_{I_{z3k}} - x_k \beta_k P_{I_{y3k}}) dx_k \\
&= \zeta_k \{ m\Omega^2 \left[-\frac{(R-e)^3}{3} \ddot{\beta}_k - \frac{(R-e)^2}{2} \ddot{R}_z \right. \\
&\quad - \beta_p < \frac{(R-e)^3}{3} + \frac{(R-e)^2}{2} e + \frac{(R-e)^3}{3} 2\dot{\theta}_z + \frac{(R-e)^3}{3} 2\dot{\zeta}_k > \\
&\quad + \cos\psi_k < \frac{(R-e)^2}{2} \beta_p \ddot{R}_x - \frac{(R-e)^3}{3} 2\dot{\zeta}_k \dot{\theta}_x + \frac{(R-e)^3}{3} (\ddot{\theta}_y - 2\dot{\theta}_x) \\
&\quad + \frac{(R-e)^2}{2} e (\ddot{\theta}_y - 2\dot{\theta}_x) - \frac{(R-e)^3}{3} \zeta_k (\ddot{\theta}_x + 2\dot{\theta}_y) > \\
&\quad + \sin\psi_k < \frac{(R-e)^2}{2} \beta_p \ddot{R}_y - \frac{(R-e)^3}{3} 2\dot{\zeta}_k \dot{\theta}_y - \frac{(R-e)^3}{3} (\ddot{\theta}_x + 2\dot{\theta}_y) \\
&\quad \left. - \frac{(R-e)^2}{2} e (\ddot{\theta}_x + 2\dot{\theta}_y) - \frac{(R-e)^3}{3} \zeta_k (\ddot{\theta}_y - 2\dot{\theta}_x) > \right\} \\
&- \beta_k \{ m\Omega^2 \left[\frac{(R-e)^3}{3} \zeta_k + \frac{(R-e)^3}{3} 2\dot{\zeta}_k \dot{\theta}_z - \frac{(R-e)^3}{3} \ddot{\theta}_z - \frac{(R-e)^2}{3} e \ddot{\theta}_z \right. \\
&\quad - \frac{(R-e)^3}{3} \ddot{\zeta}_k + \frac{(R-e)^3}{3} 2(\dot{\zeta}_k \dot{\zeta}_k + \beta_k \dot{\beta}_k) + \frac{(R-e)^3}{3} 2\dot{\beta}_k \dot{\beta}_p \\
&\quad \left. + \cos\psi_k < \frac{(R-e)^3}{3} \beta_p \ddot{\theta}_x + \frac{(R-e)^3}{3} \beta_k \ddot{\theta}_x + \frac{(R-e)^3}{3} 2\dot{\beta}_k \dot{\theta}_x - \frac{(R-e)^2}{2} \ddot{R}_y > \right.
\end{aligned}$$

$$\begin{aligned}
& + \sin\psi_k < \frac{(R-3)^3}{3} \beta_p \ddot{\theta}_y + \frac{(R-3)^3}{3} \beta_k \ddot{\theta}_y + \frac{(R-e)^3}{3} 2\dot{\beta}_k \dot{\theta}_y + \frac{(R-e)^2}{2} \ddot{R}_x >] \\
& + \Omega^2 \{ m x_I \cos\theta_{Gk} [- \frac{(R-e)^2}{2} \ddot{\beta}_k - (R-e) \ddot{R}_z \\
& \quad - \beta_p < \frac{(R-e)^2}{2} + (R-e) e + \frac{(R-e)^2}{2} 2\dot{\zeta}_k + \frac{(R-e)^2}{2} 2\dot{\theta}_z > \\
& \quad - \frac{(R-e)^2}{2} \zeta_k \phi_k + \frac{(R-e)^2}{2} \ddot{\zeta}_k \phi_k + \frac{(R-e)^2}{2} \phi_k \ddot{\theta}_z \\
& + \cos\psi_k < \frac{(R-e)^2}{2} (\ddot{\theta}_y - 2\dot{\theta}_x) + (R-e) e (\ddot{\theta}_y - 2\dot{\theta}_x) \\
& \quad - \frac{(R-e)^2}{2} \zeta_k (\ddot{\theta}_x + 2\dot{\theta}_y) - \frac{(R-e)^2}{2} 2\dot{\zeta}_k \dot{\theta}_x \\
& \quad + (R-e) (\beta_p \ddot{R}_x + \phi_k \ddot{R}_y) > \\
& + \sin\psi_k < - \frac{(R-e)^2}{2} (\ddot{\theta}_x + 2\dot{\theta}_y) - (R-e) e (\ddot{\theta}_x + 2\dot{\theta}_y) \\
& \quad - \frac{(R-e)^2}{2} \zeta_k (\ddot{\theta}_y - 2\dot{\theta}_x) - \frac{(R-e)^2}{2} 2\dot{\zeta}_k \dot{\theta}_y \\
& \quad + (R-e) (\beta_p \ddot{R}_y - \phi_k \ddot{R}_x) >] \\
& + m x_I \sin\theta_{Gk} [- \frac{(R-e)^2}{2} \zeta_k + \frac{(R-e)^2}{2} \ddot{\zeta}_k - \frac{(R-e)^2}{2} 2 (\dot{\zeta}_k \dot{\zeta}_k + \dot{\beta}_k \dot{\beta}_k) \\
& \quad - \frac{(R-e)^2}{2} 2\dot{\beta}_p \dot{\beta}_k - \frac{(R-e)^2}{2} 2\dot{\theta}_z \dot{\zeta}_k + \frac{(R-e)^2}{2} \ddot{\theta}_z \\
& \quad + (R-e) e \ddot{\theta}_z + \frac{(R-e)^2}{2} \phi_k (\beta_p + \ddot{\beta}_k) + (R-e) \phi_k \ddot{R}_z \\
& + \cos\psi_k < (R-e) \ddot{R}_y - \frac{(R-e)^2}{2} \ddot{\theta}_x (\beta_p + \beta_k) - \frac{(R-e)^2}{2} 2\dot{\beta}_k \dot{\theta}_x \\
& \quad + \frac{(R-e)^2}{2} \phi_k (-\ddot{\theta}_y + 2\dot{\theta}_x) > \\
& + \sin\psi_k < - (R-e) \ddot{R}_x - \frac{(R-e)^2}{2} \ddot{\theta}_y (\beta_p + \beta_k) - \frac{(R-e)^2}{2} 2\dot{\beta}_k \dot{\theta}_y \\
& \quad + \frac{(R-e)^2}{2} \phi_k (\ddot{\theta}_x + 2\dot{\theta}_y) >]
\end{aligned}$$

$$\begin{aligned}
& + (R-e) [(I_{MB3} \cos^2 \theta_{Gk} + I_{MB2} \sin^2 \theta_{Gk}) [-\ddot{\phi}_k + \ddot{\zeta}_k \beta_k + 2\dot{\zeta}_k \dot{\beta}_k \\
& \quad + \zeta_k \ddot{\beta}_k - \ddot{\theta}_{Gk} + \beta_p (\zeta_k - \ddot{\theta}_z) \\
& \quad + \phi_k (1 - 2\dot{\theta}_z - 2\dot{\zeta}_k) + \beta_k \zeta_k \\
& + \cos\psi_k < - (\ddot{\theta}_x + 2\dot{\theta}_y + \zeta_k (\ddot{\theta}_y - 2\dot{\theta}_x) + 2\dot{\zeta}_k \dot{\theta}_y) > \\
& + \sin\psi_k < - (\ddot{\theta}_y - 2\dot{\theta}_x - \zeta_k (\ddot{\theta}_x + 2\dot{\theta}_y) - 2\dot{\zeta}_k \dot{\theta}_x) >] \\
& + (I_{MB3} \sin^2 \theta_{Gk} + I_{MB2} \cos^2 \theta_{Gk}) [\phi_k - \ddot{\phi}_k + 2\phi_k \dot{\theta}_z \\
& \quad - \ddot{\theta}_z (\beta_p + \beta_k) - 2\dot{\beta}_k + 2\dot{\phi}_k \zeta_k \\
& \quad + 2\dot{\phi}_k \dot{\zeta}_k + 2\dot{\zeta}_k \dot{\theta}_{Gk} - 2\dot{\theta}_z \dot{\beta}_k - \ddot{\theta}_{Gk} \\
& \quad - \ddot{\theta}_x \cos\psi_k - \ddot{\theta}_y \sin\psi_k] \\
& + (I_{MB3} - I_{MB2}) \sin\theta_{Gk} \cos\theta_{Gk} [-1 - 2\dot{\theta}_z - 2\dot{\zeta}_k] \quad (5.92)
\end{aligned}$$

$$\begin{aligned}
Q_{I_{y3k}} & = \int_0^{R-e} (q_{I_{y3k}} + x_k \beta_k p_{I_{x3k}} - (x_k + u_k) p_{I_{z3k}}) dx_k \\
& = \beta_k \{ m\Omega^2 [\frac{(R-e)^3}{3} + \frac{(R-e)^2}{2} e + \frac{(R-e)^3}{3} 2\dot{\theta}_z + \frac{(R-e)^3}{3} 2\dot{\zeta}_k \\
& \quad - \frac{(R-e)^2}{2} \ddot{R}_x \cos\psi_k - \frac{(R-e)^2}{2} \ddot{R}_y \sin\psi_k] \} \\
& \quad - m\Omega^2 [- \frac{(R-e)^3}{3} \ddot{\beta}_k - \frac{(R-e)^2}{2} \ddot{R}_z \\
& - \beta_p < \frac{(R-e)^3}{3} + \frac{(R-e)^2}{2} e + \frac{(R-e)^3}{3} 2\dot{\theta}_z + \frac{(R-e)^3}{3} 2\dot{\zeta}_k > \\
& + \cos\psi_k < \frac{(R-e)^2}{2} \beta_p \ddot{R}_x - \frac{(R-e)^3}{3} 2\dot{\zeta}_k \dot{\theta}_x + \frac{(R-e)^3}{3} (\ddot{\theta}_y - 2\dot{\theta}_x)
\end{aligned}$$

$$\begin{aligned}
& + \frac{(R-e)^2}{2} e (\ddot{\theta}_y - 2\dot{\theta}_x) - \frac{(R-e)^3}{3} \zeta_k (\ddot{\theta}_x + 2\dot{\theta}_y) > \\
& + \sin\psi_k < \frac{(R-e)^2}{2} \beta_p \ddot{R}_y - \frac{(R-e)^3}{3} 2\dot{\zeta}_k \dot{\theta}_y - \frac{(R-e)^3}{3} (\ddot{\theta}_x + 2\dot{\theta}_y) \\
& - \frac{(R-e)^2}{2} e (\ddot{\theta}_x + 2\dot{\theta}_y) - \frac{(R-e)^3}{3} \zeta_k (\ddot{\theta}_y - 2\dot{\theta}_x) >] \quad (5.93)
\end{aligned}$$

$$\begin{aligned}
Q_{I_{z3k}} &= \int_0^{R-e} (q_{I_{z3k}} + (x_k + u_k) p_{I_{y3k}} - x_k \zeta_k p_{I_{x3k}}) dx_k \\
&= m\Omega^2 \left[\frac{(R-e)^3}{3} \zeta_k + \frac{(R-e)^3}{3} 2\dot{\zeta}_k \dot{\theta}_z - \frac{(R-e)^3}{3} \ddot{\theta}_z - \frac{(R-e)^2}{2} e \ddot{\theta}_z \right. \\
&\quad - \frac{(R-e)^3}{3} \ddot{\zeta}_k + \frac{(R-e)^3}{3} 2(\dot{\zeta}_k \dot{\zeta}_k + \dot{\beta}_k \dot{\beta}_k) + \frac{(R-e)^3}{3} 2\dot{\beta}_k \dot{\beta}_p \\
&\quad + \cos\psi_k < \frac{(R-e)^3}{3} \beta_p \ddot{\theta}_x + \frac{(R-e)^3}{3} \beta_k \ddot{\theta}_x + \frac{(R-e)^3}{3} 2\dot{\beta}_k \dot{\theta}_x - \frac{(R-e)^2}{2} \ddot{R}_y > \\
&\quad + \sin\psi_k < \frac{(R-e)^3}{3} \beta_p \ddot{\theta}_y + \frac{(R-e)^3}{3} \beta_k \ddot{\theta}_y + \frac{(R-e)^3}{3} 2\dot{\beta}_k \dot{\theta}_y + \frac{(R-e)^2}{2} \ddot{R}_x > \\
&\quad \left. - \zeta_k \left\{ m\Omega^2 \left[\frac{(R-e)^3}{3} + \frac{(R-e)^2}{2} e + \frac{(R-e)^3}{3} 2\dot{\theta}_z + \frac{(R-e)^3}{3} 2\dot{\zeta}_k \right. \right. \right. \\
&\quad \quad \left. \left. - \frac{(R-e)^2}{2} \ddot{R}_x \cos\psi_k - \frac{(R-e)^2}{2} \ddot{R}_y \sin\psi_k \right] \right\} \right] \quad (5.94)
\end{aligned}$$

The order of magnitude of leading terms in these expressions for the loads are listed below for convenience

$$P_{I_{x3k}} = O(1) \quad ; \quad P_{I_{y3k}} = O(\epsilon) \quad ; \quad P_{I_{z3k}} = O(\epsilon)$$

and

$$Q_{I_{x3k}} = O(\epsilon^2) \quad ; \quad Q_{I_{y3k}} = O(\epsilon) \quad ; \quad Q_{I_{z3k}} = O(\epsilon)$$

The loads at the root due to distributed aerodynamic loads are

$$\bar{P}_{A3k} = \int_0^{R-3} \bar{p}_{A3k} dx_k$$

and

$$\bar{Q}_{A3k} = \int_0^{R-e} (\bar{q}_{A3k} + \bar{r}_{p3k} \times \bar{p}_{A3k}) dx_k$$

$$\begin{aligned} P_{A_{x3k}} = & -\rho_A a b \Omega^2 \beta_k \left\{ \frac{(R-e)^3}{3} [\dot{\theta}_{Gk} + \dot{\phi}_k - \dot{\beta}_k + \dot{\zeta}_k (\theta_{Gk} + \phi_k) - \dot{r}_z (\beta_p + \beta_k) \right. \\ & \left. + \dot{\theta}_z \theta_{Gk} + \dot{\zeta}_k (\theta_{Gk} + \phi_k - \dot{\beta}_k) + \dot{\theta}_z \theta_{Gk}] \right. \\ & + \frac{(R-e)^2}{2} [-\lambda_k R + e(\dot{\theta}_{Gk} + \dot{\phi}_k) + \mu R \dot{\theta}_y - \dot{r}_z - \lambda_k R \dot{\zeta}_k \\ & \left. + e(\dot{\theta}_{Gk} + \dot{\phi}_k - \dot{\beta}_k) + b(\dot{\theta}_{Gk} + \dot{\phi}_k)] - (R-e)e\lambda_k R \right. \\ & - \cos\psi_k \left[-\frac{(R-e)^3}{3} \dot{\theta}_y + \frac{(R-e)^2}{2} [\mu R(\beta_p + \beta_k) + \theta_{Gk}(-\mu R \dot{\zeta}_k - \dot{r}_y - \mu R \dot{\theta}_z) \right. \\ & \left. - \mu R \dot{\zeta}_k \phi_k + \dot{\zeta}_k \mu R (\beta_p + \beta_k) \right. \\ & \left. + \theta_{Gk} (-\mu R \dot{\zeta}_k - \dot{r}_y - \mu R \dot{\theta}_z) - \mu R \dot{\zeta}_k (\phi_k - \dot{\beta}_k) \right] \\ & + (R-e)[e\mu r(\beta_p + \beta_k) + \lambda_k R \mu R \dot{\zeta}_k] \\ & - \sin\psi_k \left[\frac{(R-e)^3}{3} \dot{\theta}_x + \frac{(R-e)^2}{2} [-\mu R(\dot{\theta}_{Gk} + \dot{\phi}_k) + \dot{r}_x \theta_{Gk} - \mu R(\dot{\theta}_{Gk} + \dot{\phi}_k) \dot{\zeta}_k \right. \\ & \left. - \mu R \dot{\theta}_z \theta_{Gk} - \mu R (\dot{\theta}_{Gk} + \dot{\phi}_k - \dot{\beta}_k) + \dot{r}_x \theta_{Gk} \right. \\ & \left. - \mu R \dot{\zeta}_k (\dot{\theta}_{Gk} + \dot{\phi}_k) - \dot{\zeta}_k (\beta_p + \beta_k) + \dot{\theta}_z \theta_{Gk} \right] \\ & + (R-e) [-e\mu R (\dot{\theta}_{Gk} + \dot{\phi}_k) + \lambda_k R \mu R \\ & - \mu R \langle e (\dot{\theta}_{Gk} + \dot{\phi}_k) + \mu R \dot{\theta}_y - \dot{r}_z \rangle \\ & - \mu R b (\dot{\theta}_{Gk} + \dot{\phi}_k)] \\ & + \cos\psi_k \sin\psi_k \left[\frac{(R-e)^2}{2} \mu R \dot{\theta}_y \right. \end{aligned}$$

$$\begin{aligned}
& + (R-e) [-\mu R < \mu R (\beta_p + \beta_k) + 2\theta_{Gk} (-\mu R \zeta_k - R_y - \mu R \theta_z) > \\
& \qquad \qquad \qquad - 2\mu R \zeta_k \phi_k]] \\
& + \cos^2 \psi_k [- (R-e) \mu^2 R^2 \zeta_k (\beta_p + \beta_k)] \\
& + \sin^2 \psi_k [- \frac{(R-e)^2}{2} \mu R \theta_x - (R-e) \mu R < -\mu R (\theta_{Gk} + \phi_k) + 2R_x \theta_{Gk} >]] \\
& - \frac{1}{2} \rho_A a b^2 \Omega^2 \beta_k [- \frac{(R-e)^2}{2} < \ddot{\beta}_k - (\dot{\theta}_{Gk} + \dot{\phi}_k) > \\
& - \cos \psi_k [(R-e) < \mu R \ddot{\beta}_k - \mu R (\theta_{Gk} + \phi_k) >] \\
& - \sin \psi_k [(R-e) < -\mu R (\beta_p + \beta_k) - \mu R (\dot{\theta}_{Gk} + \dot{\phi}_k) >]] \cos \theta_{Gk} \\
& - \rho_A a b \Omega^2 \zeta_k \{ - \frac{c_{do}}{a} [\frac{(R-e)^3}{3}] \\
& \qquad \qquad \qquad - \frac{(R-e)^3}{3} [\dot{\beta}_k < \theta_{Gk} + \phi_k - \dot{\beta}_k] \\
& \qquad \qquad \qquad - \frac{(R-e)^2}{2} [\dot{\beta}_k (-\lambda_k R) + \lambda_k R (\theta_{Gk} + \phi_k - \dot{\beta}_k) \\
& \qquad \qquad \qquad + (-\mu R \theta_y + \dot{R}_z) \theta_{Gk}] \\
& \qquad \qquad \qquad + (R-e) [-\lambda_k R < -\lambda_k R >] \\
& \qquad \qquad \qquad - \cos \psi_k [- \frac{(R-e)^3}{3} \dot{\theta}_y \theta_{Gk} \\
& - \frac{(R-e)^2}{2} [\dot{\beta}_k \mu R (\beta_p + \beta_k) + (-\dot{\phi}_k + \dot{\beta}_k) \mu R (\beta_p + \beta_k)] \\
& + (R-e) [-\lambda_k R \mu R (\beta_p + \beta_k) - \lambda_k R \mu R (\beta_p + \beta_k)]] \\
& \qquad \qquad \qquad - \sin \psi_k [\frac{2c_{do}}{a} \frac{(R-e)^2}{2} \mu R \\
& \qquad \qquad \qquad - \frac{(R-e)^3}{3} [-\dot{\theta}_x \theta_{Gk}] - \frac{(R-e)^2}{2} [\dot{\beta}_k < -\mu R (\theta_{Gk} + \phi_k) >]
\end{aligned}$$

$$\begin{aligned}
& + (R-e) [- \lambda_k R (-\mu R (\theta_{Gk} + \phi_k)) - \mu R \theta_{Gk} (\mu R \theta_y - \dot{R}_z)] \\
& + \cos \psi_k \sin \psi_k [- \frac{(R-e)^2}{2} \dot{\theta}_y (-\mu R \theta_{Gk}) \\
& + (R-e) [- \mu R (\beta_p + \beta_k) < \mu R \theta_{Gk} + \mu R \phi_k >]] \\
& + \cos^2 \psi_k [(R-e) \mu^2 R^2 (\beta_p + \beta_k)^2] \\
& + \sin^2 \psi_k [\frac{(R-e)^2}{2} [- \mu R \theta_{Gk} \dot{\theta}_x] \\
& \quad - \frac{c_{do}}{a} (R-e) [\mu^2 R^2]]] \\
& + \frac{1}{2} \rho_A a b^2 \Omega^2 \zeta_k \{ (R-e) [- \mu R \theta_{Gk} \sin \theta_{Gk}] (-\cos \psi_k) \} \\
\end{aligned} \tag{5.95}$$

$$\begin{aligned}
P_{A_{y3k}} & = \rho_a a b \Omega^2 \{ - \frac{c_{do}}{a} [\frac{(R-e)^3}{3} (1 + 2\dot{\zeta}_k + 2\dot{\theta}_z) + 2 \frac{(R-e)^2}{2} e] \\
& - \frac{(R-e)^3}{3} [\dot{\beta}_k < \theta_{Gk} + \phi_k - \dot{\beta}_k + \dot{\zeta}_k (\theta_{Gk} + \phi_k) \\
& \quad - \zeta_k (\beta_p + \beta_k) + \dot{\theta}_z \theta_{Gk} > \\
& + \zeta_k (\beta_p + \beta_k) < \theta_{Gk} + \phi_k - \dot{\beta}_k >] \\
& - \frac{(R-e)^2}{2} [\dot{\beta}_k < -\lambda_k R + e(\theta_{Gk} + \phi_k) + \mu R \theta_y - \dot{R}_z > \\
& + \lambda_k R < \theta_{Gk} + \phi_k - \dot{\beta}_k + \dot{\zeta}_k (\theta_{Gk} + \phi_k) - \zeta_k (\beta_p + \beta_k) \\
& \quad + \dot{\theta}_z \theta_{Gk} > \\
& + (-\mu R \theta_y + \dot{R}_z) < \theta_{Gk} + \phi_k - \dot{\beta}_k + \dot{\zeta}_k \theta_{Gk} > \\
& + \zeta_k (\beta_p + \beta_k) < -\lambda_k R > + \dot{\beta}_k b (\dot{\theta}_{Gk} + \dot{\phi}_k)] \\
\end{aligned}$$

$$\begin{aligned}
& + (R-e) [-\lambda_k R < -\lambda_k R + e(\theta_{Gk} + \phi_k) + \mu R \theta_y - \dot{R}_z > \\
& \quad + (\mu R \theta_y - \dot{R}_z) < -\lambda_k R + e \theta_{Gk} + \mu R \theta_y - \dot{R}_z > \\
& \quad \quad - \lambda_k R b (\dot{\theta}_{Gk} + \dot{\phi}_k)] \\
& - \cos \psi_k [\frac{2c_{do}}{a} [\frac{(R-e)^2}{2} (\mu R \zeta_k + \mu R \theta_z + \dot{R}_y)] \\
& - \frac{(R-e)^3}{3} [-\dot{\beta}_k \dot{\theta}_y - \zeta_k \dot{\theta}_x \theta_{Gk} + \dot{\theta}_y (\theta_{Gk} + \phi_k - \dot{\beta}_k) + \zeta_k \theta_{Gk} \dot{\theta}_y] \\
& - \frac{(R-e)^2}{2} [\dot{\beta}_k < \mu R (\beta_p + \beta_k) + \theta_{Gk} (-\mu R \zeta_k - \mu R \theta_z - \dot{R}_y) - \phi_k \mu R \zeta_k > \\
& \quad - \dot{\theta}_y < \lambda_k R - \mu R \theta_y + \dot{R}_z > \\
& \quad + \zeta_k (\beta_p + \beta_k) < \mu R (\beta_p + \beta_k) > \\
& \quad - \theta_{Gk} < -e \dot{\theta}_y + (\beta_p + \beta_k) (\mu R - \dot{R}_x) > \\
& \quad + (-\dot{\phi}_k + \dot{\beta}_k) < \mu R (\beta_p + \beta_k) > \\
& \quad - \lambda_k R \dot{\theta}_y - \zeta_k (\theta_{Gk} + \phi_k) \mu R (\beta_p + \beta_k) \\
& \quad + \dot{\theta}_y < e \theta_{Gk} + \mu R \theta_y - \dot{R}_z > \\
& \quad + (\dot{\theta}_z \theta_{Gk} - \zeta_k (\beta_p + \beta_k)) < -\mu R (\beta_p + \beta_k) >] \\
& + (R-e) [-\lambda_k R < \mu R (\beta_p + \beta_k) + \theta_{Gk} (-\mu R \zeta_k - \mu R \theta_z - \dot{R}_y) - \mu R \zeta_k \phi_k > \\
& \quad + (\mu R \theta_y - \dot{R}_z) < \mu R (\beta_p + \beta_k) - \mu R \zeta_k \theta_{Gk} > \\
& \quad - \lambda_k R < \mu R (\beta_p + \beta_k) > \\
& \quad + [e (\theta_{Gk} + \phi_k) + \mu R \theta_y - \dot{R}_z] < \mu R (\beta_p + \beta_k) > \\
& \quad + \mu R (\beta_p + \beta_k) b (\dot{\theta}_{Gk} + \dot{\phi}_k)]]
\end{aligned}$$

$$\begin{aligned}
& - \sin\psi_k \left[\frac{2c_{do}}{a} \left[\frac{(R-e)^2}{2} \langle \mu R (1 + \dot{\zeta}_k + \dot{\theta}_z) - \dot{R}_x \rangle + e\mu R(R-e) \right] \right. \\
& - \frac{(R-e)^3}{3} \left[\dot{\beta}_k \dot{\theta}_x - \dot{\theta}_{Gk} \dot{\zeta}_k \dot{\theta}_y - \dot{\theta}_x (\dot{\theta}_{Gk} + \dot{\phi}_k - \dot{\beta}_k) - \dot{\theta}_{Gk} \dot{\zeta}_k \dot{\theta}_x \right] \\
& - \frac{(R-e)^2}{2} \left[\dot{\beta}_k \langle -\mu R (\dot{\theta}_{Gk} + \dot{\phi}_k) + \dot{\theta}_{Gk} \dot{R}_x \rangle \right. \\
& \quad + \dot{\theta}_x \langle \lambda_k R - \mu R \dot{\theta}_y + \dot{R}_z \rangle \\
& \quad + \dot{\zeta}_k (\beta_p + \beta_k) \langle -\mu R (\dot{\theta}_{Gk} + \dot{\phi}_k) \rangle \\
& \quad - \dot{\theta}_{Gk} \langle e \dot{\theta}_x + (\beta_p + \beta_k) (-\mu R \dot{\theta}_z - \dot{R}_y) \rangle \\
& \quad \left. + \lambda_k R \dot{\theta}_x - \dot{\theta}_x \langle e \dot{\theta}_{Gk} + \mu R \dot{\theta}_y - \dot{R}_z \rangle \right] \\
& + (R-e) \left[- \lambda_k R \langle -\mu R (\dot{\theta}_{Gk} + \dot{\theta}_k) + \dot{\theta}_{Gk} \dot{R}_x \rangle \right. \\
& \quad \left. + (\mu R \dot{\theta}_y - \dot{R}_z) \langle -\mu R (\dot{\theta}_{Gk} + \dot{\phi}_k) \rangle \right] \\
& + \cos\psi_k \sin\psi_k \left[- \frac{2c_{do}}{a} \left[(R-e) \mu R (\mu R \dot{\zeta}_k + \mu R \dot{\theta}_z + \dot{R}_y) \right] \right. \\
& \quad - \frac{(R-e)^3}{3} 2 \dot{\theta}_y \dot{\theta}_x \\
& - \frac{(R-e)^2}{2} \left[- \dot{\theta}_x \langle 2\mu R (\beta_p + \beta_k) - 2\mu R \dot{\zeta}_k \dot{\theta}_{Gk} \rangle \right. \\
& \quad \left. + \dot{\theta}_y \langle -\mu R (\dot{\theta}_{Gk} + \dot{\phi}_k) \rangle \right] \\
& + (R-e) \left[\mu R \dot{\theta}_{Gk} e \dot{\theta}_y - \mu R (\beta_p + \beta_k) (\mu R \dot{\theta}_{Gk} + \mu R \dot{\phi}_k) \right. \\
& \quad \left. + 2\mu R \dot{\theta}_{Gk} \dot{R}_x (\beta_p + \beta_k) \right] \\
& \quad + \cos^2\psi_k \left[\frac{(R-e)^3}{3} \dot{\theta}_y^2 \right. \\
& - \frac{(R-e)^2}{2} \left[2 \dot{\theta}_y (\beta_p + \beta_k) \mu R - \mu R \dot{\zeta}_k \dot{\theta}_{Gk} \dot{\theta}_y \right] \\
& \quad \left. + (R-e) \left[\mu^2 R^2 (\beta_p + \beta_k)^2 \right] \right]
\end{aligned}$$

$$\begin{aligned}
& + \mu R (\beta_p + \beta_k) < -\mu R \zeta_k (\theta_{Gk} + \phi_k) + \theta_{Gk} (-\dot{R}_y - \mu R \dot{\theta}_z) >]] \\
& \quad + \sin^2 \psi_k [\frac{(R-e)^3}{3} \dot{\theta}_x^2 \\
& + \frac{(R-e)^2}{2} [-\mu R \theta_{Gk} (\dot{\theta}_x + \zeta_k \dot{\theta}_y) - \mu R \phi_k \dot{\theta}_x] \\
& + (R-e) [-\mu R \theta_{Gk} < e \dot{\theta}_x + (\beta_p + \beta_k) (-\mu R \dot{\theta}_z - \dot{R}_y) > \\
& \quad - \frac{c_{do}}{a} < \mu^2 R^2 - 2\mu R \dot{R}_x >]] \} \\
- \frac{1}{2} \rho_A a b^2 \Omega^2 \{ & - \frac{(R-e)^2}{2} [(\ddot{\beta}_k - (\dot{\theta}_{Gk} + \dot{\phi}_k)) < \sin \theta_{Gk} + \phi_k \cos \theta_{Gk} > \\
& \quad - \ddot{\zeta}_k \theta_{Gk} \sin \theta_{Gk}] \\
& + (R-e) \sin \theta_{Gk} (\mu R \ddot{\theta}_y - \ddot{R}_z) \\
& - \cos \psi_k [- \frac{(R-e)^2}{2} (\ddot{\theta}_y - \dot{\theta}_x) \sin \theta_{Gk} \\
& + (R-e) [(\mu R \ddot{\beta}_k - \mu R (\theta_{Gk} + \phi_k)) (\sin \theta_{Gk} + \phi_k \cos \theta_{Gk}) \\
& \quad - \mu R \dot{\zeta}_k \theta_{Gk} \sin \theta_{Gk}]] \\
& - \sin \psi_k [\frac{(R-e)^2}{2} (\ddot{\theta}_x + \dot{\theta}_y) \sin \theta_{Gk} \\
& - (R-e) [(\mu R (\beta_p + \beta_k) + \mu R (\dot{\theta}_{Gk} + \dot{\phi}_k)) \\
& \quad (\sin \theta_{Gk} + \phi_k \cos \theta_{Gk}) \\
& + \mu R \zeta_k \theta_{Gk} \sin \theta_{Gk}]] \} \tag{5.96}
\end{aligned}$$

$$\begin{aligned}
P_{A_{z3k}} = & \rho_A a b \Omega^2 \left\{ \frac{(R-e)^3}{3} \left[\theta_{Gk} + \phi_k - \dot{\beta}_k + \dot{\zeta}_k (\theta_{Gk} + \phi_k) - \zeta_k (\beta_p + \beta_k) \right. \right. \\
& \left. \left. + \dot{\theta}_z \theta_{Gk} + \dot{\zeta}_k \langle \theta_{Gk} + \phi_k - \dot{\beta}_k \rangle + \dot{\theta}_z \theta_{Gk} \right] \right. \\
& + \frac{(R-e)^2}{2} \left[- \lambda_k R + e (\theta_{Gk} + \theta_k) + \mu R \theta_y - \dot{R}_z - \lambda_k R \dot{\zeta}_k \right. \\
& \left. + e \langle \theta_{Gk} + \phi_k - \dot{\beta}_k \rangle + b (\dot{\theta}_{Gk} + \dot{\phi}_k) \right] \\
& - (R-e) e \lambda_k R \\
& - \cos \psi_k \left[- \frac{(R-e)^3}{3} \dot{\theta}_y \right. \\
& + \frac{(R-e)^2}{2} \left[\mu R (\beta_p + \beta_k) + \theta_{Gk} (-\mu R \dot{\zeta}_k - \dot{R}_y - \mu R \theta_z) \right. \\
& \left. - \mu R \dot{\zeta}_k \phi_k + \dot{\zeta}_k \mu R (\beta_p + \beta_k) \right. \\
& \left. + \theta_{Gk} (-\mu R \dot{\zeta}_k - \dot{R}_y - \mu R \theta_z) - \mu R \dot{\zeta}_k (\phi_k - \dot{\beta}_k) \right] \\
& + (R-e) \left[e \mu R (\beta_p + \beta_k) + \lambda_k R \mu R \dot{\zeta}_k \right] \\
& - \sin \psi_k \left[\frac{(R-e)^3}{3} \dot{\theta}_x \right. \\
& + \frac{(R-e)^2}{2} \left[- \mu R (\theta_{Gk} + \phi_k) + \dot{R}_x \theta_{Gk} - \mu R (\theta_{Gk} + \phi_k) \dot{\zeta}_k \right. \\
& - \mu R \dot{\theta}_z \theta_{Gk} - \mu R (\theta_{Gk} + \phi_k - \dot{\beta}_k) + \dot{R}_x \theta_{Gk} \\
& \left. - \mu R \langle \dot{\zeta}_k (\theta_{Gk} + \phi_k) - \zeta_k (\beta_p + \beta_k) + \dot{\theta}_z \theta_{Gk} \rangle \right] \\
& + (R-e) \left[- e \mu R (\theta_{Gk} + \phi_k) + \lambda_k R \mu R \right. \\
& - \mu R \langle e (\theta_{Gk} + \phi_k) + \mu R \theta_y - \dot{R}_z \rangle \\
& \left. - \mu R b (\dot{\theta}_{Gk} + \dot{\phi}_k) \right] \left. \right\}
\end{aligned}$$

$$\begin{aligned}
& + \cos\psi_k \sin\psi_k \left[\frac{(R-e)^2}{2} \mu R \dot{\theta}_y \right. \\
& + (R-e) \left[-\mu R < \mu R (\beta_p + \beta_k) + 2\theta_{Gk} (-\mu R \zeta_k - \dot{R}_y - \mu R \dot{\theta}_z) > \right. \\
& \quad \left. \left. - 2\mu R \zeta_k \dot{\phi}_k \right] \right] \\
& + \cos^2\psi_k \left[- (R-e) \mu^2 R^2 \zeta_k (\beta_p + \beta_k) \right] \\
& + \sin^2\psi_k \left[- \frac{(R-e)^2}{2} \mu R \dot{\theta}_x - (R-e) \mu R < - \mu R (\theta_{Gk} + \phi_k) + 2\dot{R}_x \theta_{Gk} > \right] \\
& + \frac{1}{2} \rho_A a b^2 \Omega^2 \left[- \frac{(R-e)^2}{2} < \ddot{\beta}_k - (\dot{\theta}_{Gk} + \dot{\phi}_k) > \right. \\
& - \cos\psi_k \left[(R-e) < \mu R \ddot{\beta}_k - \mu R (\theta_{Gk} + \phi_k) > \right] \\
& \left. - \sin\psi_k \left[(R-e) < - \mu R (\beta_p + \beta_k) - \mu R (\dot{\theta}_{Gk} + \dot{\phi}_k) > \right] \right] \cos\theta_{Gk}
\end{aligned} \tag{5.97}$$

The aerodynamic moments at the blade root are

$$\begin{aligned}
Q_{A_{x3k}} & = \int_0^{R-e} (q_{A_{x3k}} + x_k \zeta_k p_{A_{z3k}} - x_k \beta_k p_{A_{y3k}}) dx_k \\
& = \rho_A a b \Omega^2 \zeta_k \left\{ \frac{(R-e)^4}{4} [\theta_{Gk} + \phi_k - \dot{\beta}_k + \dot{\zeta}_k (\theta_{Gk} + \phi_k) - \zeta_k (\beta_p + \beta_k) \right. \\
& \quad \left. + \dot{\theta}_z \theta_{Gk} + \dot{\zeta}_k < \theta_{Gk} + \phi_k - \dot{\beta}_k > + \dot{\theta}_z \theta_{Gk}] \right. \\
& + \frac{(R-e)^3}{3} \left[- \lambda_k R + e (\theta_{Gk} + \phi_k) + \mu R \dot{\theta}_y - \dot{R}_z - \lambda_k R \dot{\zeta}_k \right. \\
& \quad \left. + e (\theta_{Gk} + \phi_k - \dot{\beta}_k) + b (\dot{\theta}_{Gk} + \dot{\phi}_k) \right] \\
& \quad \left. + \frac{(R-e)^2}{2} e (-\lambda_k R) \right. \\
& \quad \left. - \cos\psi_k \left[- \frac{(R-e)^4}{4} \dot{\theta}_y \right. \right. \\
& \quad \left. \left. + \frac{(R-e)^3}{3} [\mu R (\beta_p + \beta_k) + \theta_{Gk} (-\mu R \zeta_k - \dot{R}_y - \mu R \dot{\theta}_z)] \right] \right.
\end{aligned}$$

$$\begin{aligned}
& - \mu R \zeta_k \dot{\phi}_k + \dot{\zeta}_k \mu R (\beta_p + \beta_k) \\
& + \theta_{Gk} (-\mu R \zeta_k - \dot{R}_y - \mu R \dot{\theta}_z) \\
& + (\dot{\phi}_k - \dot{\beta}_k) (-\mu R \zeta_k)] \\
& + \frac{(R-e)^2}{2} [e \mu R (\beta_p + \beta_k) + \lambda_k R \mu R \zeta_k]] \\
& \qquad \qquad \qquad - \sin \psi_k [\frac{(R-e)^4}{4} \dot{\theta}_x \\
& + \frac{(R-e)^3}{3} [-\mu R (\theta_{Gk} + \phi_k) + \dot{R}_x \theta_{Gk} - \mu R (\theta_{Gk} + \phi_k) \dot{\zeta}_k \\
& \qquad \qquad \qquad - \mu R \dot{\theta}_z \theta_{Gk} - \mu R (\theta_{Gk} + \phi_k - \dot{\beta}_k) + \dot{R}_x \theta_{Gk} \\
& \qquad \qquad \qquad - \mu R < \dot{\zeta}_k (\theta_{Gk} + \phi_k) - \zeta_k (\beta_p + \beta_k) + \dot{\theta}_z \theta_{Gk} >] \\
& \qquad \qquad \qquad + \frac{(R-e)^2}{2} [e < -\mu R (\theta_{Gk} + \phi_k) > + \lambda_k R \mu R \\
& - \mu R < e (\theta_{Gk} + \phi_k) + \mu R \theta_y - \dot{R}_z > - \mu R b (\dot{\theta}_{Gk} + \dot{\phi}_k)]] \\
& \qquad \qquad \qquad + \cos \psi_k \sin \psi_k [\frac{(R-e)^3}{3} \mu R \dot{\theta}_y \\
& + \frac{(R-e)^2}{2} [-\mu R < \mu R (\beta_p + \beta_k) + \theta_{Gk} (-\mu R \zeta_k - \dot{R}_y - \mu R \dot{\theta}_z) \\
& \qquad \qquad \qquad - \mu R \zeta_k \dot{\phi}_k > \\
& \qquad \qquad \qquad + \mu R \zeta_k < \mu R (\theta_{Gk} + \phi_k) > \\
& \qquad \qquad \qquad - \mu R \theta_{Gk} < -\mu R \dot{\theta}_z - \dot{R}_y >]] \\
& + \cos^2 \psi_k [-\frac{(R-e)^2}{2} \mu^2 R^2 \zeta_k (\beta_p + \beta_k)] \\
& + \sin^2 \psi_k [-\frac{(R-e)^3}{3} \mu R \dot{\theta}_x
\end{aligned}$$

$$\begin{aligned}
& + \frac{(R-e)^2}{2} [-\mu R < -\mu R (\theta_{Gk} + \phi_k) + \dot{R}_x \theta_{Gk} > - \mu R \theta_{Gk} \dot{R}_x]] \} \\
& + \frac{1}{2} \rho_A a b^2 \Omega^2 \zeta_k \{ - \frac{(R-e)^3}{3} < \ddot{\beta}_k - (\dot{\theta}_{Gk} + \dot{\phi}_k) > \\
& \quad - \cos \psi_k < \frac{(R-e)^2}{2} [\mu R \ddot{\beta}_k - \mu R (\theta_{Gk} + \phi_k)] > \\
& \quad - \sin \psi_k < \frac{(R-e)^2}{2} [- \mu R (\beta_p + \beta_k) - \mu R (\dot{\theta}_{Gk} + \dot{\phi}_k)] > \} \cos \theta_{Gk} \\
& - \rho_A a b \Omega^2 \beta_k (1 + \zeta_k^2) \{ - \frac{c_{do}}{a} [\frac{(R-e)^4}{4} < 1 + 2\zeta_k \dot{\theta}_z > + \frac{(R-e)^3}{3} 2e] \\
& \quad - \frac{(R-e)^4}{4} [\dot{\beta}_k < \theta_{Gk} + \phi_k - \dot{\beta}_k + \zeta_k (\theta_{Gk} + \phi_k) \\
& \quad \quad \quad - \zeta_k (\beta_p + \beta_k) + \dot{\theta}_z \theta_{Gk} > \\
& \quad + \zeta_k (\beta_p + \beta_k) < \theta_{Gk} + \phi_k - \dot{\beta}_k >] \\
& \quad - \frac{(R-e)^3}{3} [\dot{\beta}_k < - \lambda_k R + e(\theta_{Gk} + \phi_k) + \mu R \theta_z - \dot{R}_z > \\
& \quad + \lambda_k R < \theta_{Gk} + \phi_k - \dot{\beta}_k + \zeta_k (\theta_{Gk} + \phi_k) - \zeta_k (\beta_p + \beta_k) \\
& \quad \quad \quad + \dot{\theta}_z \theta_{Gk} > \\
& \quad + (-\mu R \theta_y + \dot{R}_z) < \theta_{Gk} + \phi_k - \dot{\beta}_k + \zeta_k \theta_{Gk} > \\
& \quad + \zeta_k (\beta_p + \beta_k) < -\lambda_k R > + \dot{\beta}_k b (\dot{\theta}_{Gk} + \dot{\phi}_k)] \\
& + \frac{(R-e)^2}{2} [-\lambda_k R < -\lambda_k R + e(\theta_{Gk} + \phi_k) + \mu R \theta_y - \dot{R}_z > \\
& \quad + (\mu R \theta_y - \dot{R}_z) < - \lambda_k R + e\theta_{Gk} + \mu R \theta_y - \dot{R}_z > \\
& \quad \quad \quad - \lambda_k R b (\dot{\theta}_{Gk} + \dot{\phi}_k)] \\
& - \cos \psi_k [\frac{2c_{do}}{a} [\frac{(R-e)^3}{3} < \mu R \zeta_k + \mu R \theta_z + \dot{R}_y >]
\end{aligned}$$

$$\begin{aligned}
& - \frac{(R-e)^4}{4} [-\dot{\beta}_k \dot{\theta}_y - \zeta_k \dot{\theta}_x \theta_{Gk} + \dot{\theta}_y \langle \theta_{Gk} + \phi_k - \dot{\beta}_k \rangle + \dot{\zeta}_k \theta_{Gk} \dot{\theta}_y] \\
& - \frac{(R-e)^3}{3} [\dot{\beta}_k \langle \mu R (\beta_p + \beta_k) + \theta_{Gk} (-\mu R \zeta_k - \mu R \theta_z - \dot{R}_y) \rangle \\
& \qquad \qquad \qquad - \phi_k \mu R \zeta_k > \\
& + (\lambda_k R - \mu R \theta_y + \dot{R}_z) (-\dot{\theta}_y) + \mu R \zeta_k (\beta_p + \beta_k)^2 \\
& \qquad \qquad \qquad - \theta_{Gk} \langle -e \dot{\theta}_y + (\beta_p + \beta_k) (\mu R - \dot{R}_x) \rangle \\
& \qquad \qquad \qquad + (-\phi_k + \dot{\beta}_k) \mu R (\beta_p + \beta_k) - \lambda_k R \dot{\theta}_y \\
& \qquad \qquad \qquad - \zeta_k (\theta_{Gk} + \phi_k) \mu R (\beta_p + \beta_k) + \dot{\theta}_y \langle e \theta_{Gk} + \mu R \theta_y - \dot{R}_z \rangle \\
& \qquad \qquad \qquad + (\dot{\theta}_z \theta_{Gk} - \zeta_k (\beta_p + \beta_k)) \langle -\mu R (\beta_p + \beta_k) \rangle] \\
& + \frac{(R-e)^2}{2} [-\lambda_k R (\mu R (\beta_p + \beta_k) + \theta_{Gk} (-\mu R \zeta_k - \mu R \theta_z - \dot{R}_y) - \mu R \zeta_k \phi_k) \\
& \qquad \qquad \qquad + (\mu R \theta_y - \dot{R}_z) \langle \mu R (\beta_p + \beta_k) - \mu R \zeta_k \theta_{Gk} \rangle \\
& \qquad \qquad \qquad - \lambda_k R \mu R (\beta_p + \beta_k) \\
& \qquad \qquad \qquad + [e (\theta_{Gk} + \phi_k) + \mu R \theta_y - \dot{R}_z] \mu R (\beta_p + \beta_k) \\
& \qquad \qquad \qquad + \mu R (\beta_p + \beta_k) b (\dot{\theta}_{Gk} + \dot{\phi}_k)]] \\
& - \sin \psi_k [\frac{2c}{a} \frac{do}{a} [\frac{(R-e)^3}{3} \langle \mu R (1 + \dot{\zeta}_k + \dot{\theta}_z) - \dot{R}_x \rangle + \frac{(R-e)^2}{2} e \mu R] \\
& - \frac{(R-e)^4}{4} [\dot{\beta}_k \dot{\theta}_x - \theta_{Gk} \zeta_k \dot{\theta}_y - \dot{\theta}_x \langle \theta_{Gk} + \phi_k - \dot{\beta}_k \rangle - \theta_{Gk} \zeta_k \dot{\theta}_x] \\
& \qquad \qquad \qquad - \frac{(R-e)^3}{3} [\dot{\beta}_k \langle -\mu R (\theta_{Gk} + \phi_k) + \theta_{Gk} \dot{R}_x \rangle \\
& \qquad \qquad \qquad + \dot{\theta}_x (\lambda_k R - \mu R \theta_y + \dot{R}_z) + \zeta_k (\beta_p + \beta_k) \langle -\mu R (\theta_{Gk} + \phi_k) \rangle]
\end{aligned}$$

$$\begin{aligned}
& - \dot{\theta}_{Gk} < e \dot{\theta}_x + (\beta_p + \beta_k)(-\mu R \dot{\theta}_z - \dot{R}_y) + \lambda_k R \dot{\theta}_x \\
& \quad - \dot{\theta}_x (e \dot{\theta}_{Gk} + \mu R \dot{\theta}_y - \dot{R}_z)] \\
& + \frac{(R-e)^2}{2} [- \lambda_k R < - \mu R (\dot{\theta}_{Gk} + \dot{\phi}_k) + \dot{\theta}_{Gk} \dot{R}_x > \\
& + (\mu R \dot{\theta}_y - \dot{R}_z) < - \mu R (\dot{\theta}_{Gk} + \dot{\phi}_k) >]] \\
& + \cos \psi_k \sin \psi_k [- \frac{2c_{do}}{a} \frac{(R-e)^2}{2} [\mu R < \mu R \zeta_k + \mu R \dot{\theta}_z + \dot{R}_y > \\
& \quad - \frac{(R-e)^4}{4} 2 \dot{\theta}_y \dot{\theta}_x \\
& - \frac{(R-e)^3}{3} [- 2 \dot{\theta}_x < \mu R (\beta_p + \beta_k) - \mu R \zeta_k \dot{\theta}_{Gk} > \\
& \quad + \dot{\theta}_y < - \mu R (\dot{\theta}_{Gk} + \dot{\phi}_k) >] \\
& \quad + \frac{(R-e)^2}{2} [\mu R \dot{\theta}_{Gk} e \dot{\theta}_y - \mu^2 R^2 (\beta_p + \beta_k) (\dot{\theta}_{Gk} + \dot{\phi}_k) \\
& \quad + 2 \mu R \dot{\theta}_{Gk} \dot{R}_x (\beta_p + \beta_k)]] \\
& \quad + \cos^2 \psi_k [\frac{(R-e)^4}{4} \dot{\theta}_y^2 \\
& - \frac{(R-e)^3}{3} [2 \dot{\theta}_y (\beta_p + \beta_k) \mu R - \mu R \zeta_k \dot{\theta}_{Gk} \dot{\theta}_y] \\
& \quad + \frac{(R-e)^2}{2} [\mu^2 R^2 (\beta_p + \beta_k)^2 \\
& + \mu R (\beta_p + \beta_k) < - \mu R \zeta_k (\dot{\theta}_{Gk} + \dot{\phi}_k) + \dot{\theta}_{Gk} (-\dot{R}_y - \mu R \dot{\theta}_z) >]] \\
& \quad + \sin^2 \psi_k [\frac{(R-e)^4}{4} \dot{\theta}_x^2 \\
& \quad + \frac{(R-e)^3}{3} [- \mu R \dot{\theta}_{Gk} (\dot{\theta}_x + \zeta_k \dot{\theta}_y) - \mu R \dot{\phi}_k \dot{\theta}_x] \\
& \quad + \frac{(R-e)^2}{2} [- \mu R \dot{\theta}_{Gk} < e \dot{\theta}_x + (\beta_p + \beta_k)(-\mu R \dot{\theta}_z - \dot{R}_y) > \\
& \quad - \frac{c_{do}}{a} < \mu^2 R^2 - 2 \mu R \dot{R}_x >]] }
\end{aligned}$$

$$\begin{aligned}
& + (\dot{\phi}_k - \dot{\beta}_k) (-\mu R \dot{\zeta}_k)] \\
& + (R-e) [e \mu R (\beta_p + \beta_k) + \lambda_k R \mu R \dot{\zeta}_k]] \\
& \quad - \sin \psi_k [\frac{(R-e)^3}{3} \dot{\theta}_x \\
& + \frac{(R-e)^2}{2} [-\mu R (\theta_{Gk} + \phi_k) + \dot{R}_x \theta_{Gk} - \mu R (\theta_{Gk} + \phi_k) \dot{\zeta}_k \\
& \quad - \mu R \dot{\theta}_z \theta_{Gk} - \mu R < \theta_{Gk} + \phi_k - \dot{\beta}_k > + \dot{R}_x \theta_{Gk} \\
& \quad - \mu R < \dot{\zeta}_k (\theta_{Gk} + \phi_k) - \zeta_k (\beta_p + \beta_k) + \dot{\theta}_z \theta_{Gk} >] \\
& + (R-e) [e < -\mu R (\theta_{Gk} + \phi_k) > + \lambda_k R \mu R \\
& \quad - \mu R < e (\theta_{Gk} + \phi_k) + \mu R \dot{\theta}_y - \dot{R}_z > \\
& \quad \quad - \mu R b (\dot{\theta}_{Gk} + \dot{\phi}_k)]] \\
& + \cos \psi_k \sin \psi_k [\frac{(R-e)^2}{2} \mu R \dot{\theta}_y \\
& + (R-e) [-\mu R < \mu R (\beta_p + \beta_k) + \theta_{Gk} (-\mu R \dot{\zeta}_k - \dot{R}_y - \mu R \dot{\theta}_z) \\
& \quad \quad - \mu R \zeta_k \dot{\phi}_k > \\
& \quad + \mu R \zeta_k < \mu R (\theta_{Gk} + \phi_k) > \\
& \quad - \mu R \theta_{Gk} < -\mu R \dot{\theta}_z - \dot{R}_y >]] \\
& + \cos^2 \psi_k [- (R-e) \mu^2 R^2 \zeta_k (\beta_p + \beta_k)] \\
& + \sin^2 \psi_k [- \frac{(R-e)^2}{2} \mu R \dot{\theta}_x \\
& + (R-e) [-\mu R < -\mu R (\theta_{Gk} + \phi_k) + \dot{R}_x \theta_{Gk} > - \mu R \dot{\theta}_{Gk} \dot{R}_x]]]
\end{aligned}$$

$$\begin{aligned}
& + \frac{1}{2} \rho_A a b^2 \Omega^2 (x_A - \frac{b}{2}) \{ - \frac{(R-e)^2}{2} \langle \ddot{\beta}_k - (\dot{\theta}_{Gk} + \dot{\phi}_k) \rangle \\
& \quad - \cos\psi_k \langle (R-e) [\mu R \ddot{\beta}_k - \mu R (\dot{\theta}_{Gk} + \dot{\phi}_k)] \rangle \\
& \quad - \sin\psi_k \langle (R-e) [-\mu R (\dot{\beta}_p + \dot{\beta}_k) - \mu R (\dot{\theta}_{Gk} + \dot{\phi}_k)] \rangle \} \\
& - \frac{b^2}{8} (\ddot{\theta}_{Gk} + \ddot{\phi}_k) \Omega^2 \frac{1}{2} \rho_A a b^2 (R-e) \\
& + \frac{1}{2} \rho_A a b^2 \Omega^2 \frac{b}{2} (\dot{\theta}_{Gk} + \dot{\phi}_k) \{ - \frac{(R-e)^2}{2} - (R-e) e \\
& \quad - (R-e) \langle \mu R \zeta_k \cos\psi_k + \mu R \sin\psi_k \rangle \} \\
\end{aligned} \tag{5.98}$$

$$Q_{A_{y3k}} = \int_0^{R-e} (q_{A_{y3k}} + x_k \beta_k p_{A_{x3k}} - (x_k + u_k) p_{A_{z3k}}) dx_k$$

Neglecting higher order terms

$$\begin{aligned}
Q_{A_{y3k}} & = \int_0^{R-e} - x_k p_{A_{z3k}} dx_k \\
& = - \rho_A a b \Omega^2 \{ \frac{(R-e)^4}{4} [\dot{\theta}_{Gk} + \dot{\phi}_k - \dot{\beta}_k + \dot{\zeta}_k (\dot{\theta}_{Gk} + \dot{\phi}_k) - \dot{\zeta}_k (\dot{\beta}_p + \dot{\beta}_k) \\
& \quad + \dot{\theta}_z \dot{\theta}_{Gk} + \dot{\zeta}_k (\dot{\theta}_{Gk} + \dot{\phi}_k - \dot{\beta}_k) + \dot{\theta}_z \dot{\theta}_{Gk}] \\
& + \frac{(R-e)^3}{3} [- \lambda_k R + e(\dot{\theta}_{Gk} + \dot{\phi}_k) + \mu R \dot{\theta}_y - \dot{R}_z - \lambda_k R \dot{\zeta}_k \\
& \quad + e(\dot{\theta}_{Gk} + \dot{\phi}_k - \dot{\beta}_k) + b(\dot{\theta}_{Gk} + \dot{\phi}_k)] \\
& \quad + \frac{(R-e)^2}{2} e (-\lambda_k R) \\
& \quad - \cos\psi_k [- \frac{(R-e)^4}{4} \dot{\theta}_y
\end{aligned}$$

$$\begin{aligned}
& + \frac{(R-e)^3}{3} [\mu R (\beta_p + \beta_k) + \theta_{Gk} (-\mu R \zeta_k - \dot{R}_y - \mu R \theta_z) \\
& \quad - \mu R \zeta_k \phi_k + \dot{\zeta}_k \mu R (\beta_p + \beta_k) \\
& \quad + \theta_{Gk} (-\mu R \zeta_k - \dot{R}_y - \mu R \theta_z) \\
& \quad - \mu R \zeta_k (\phi_k - \dot{\beta}_k)] \\
& + \frac{(R-e)^2}{2} [e \mu R (\beta_p + \beta_k) + \lambda_k R \mu R \zeta_k]] \\
& - \sin \psi_k [\frac{(R-e)^4}{4} \dot{\theta}_x \\
& + \frac{(R-e)^3}{3} [-\mu R (\theta_{Gk} + \phi_k) + \dot{R}_x \theta_{Gk} - \mu R (\theta_{Gk} + \phi_k) \dot{\zeta}_k \\
& \quad - \mu R \dot{\theta}_z \theta_{Gk} - \mu R (\theta_{Gk} + \phi_k - \dot{\beta}_k) + \dot{R}_x \theta_{Gk} \\
& \quad - \mu R < \dot{\zeta}_k (\theta_{Gk} + \phi_k) - \zeta_k (\beta_p + \beta_k) + \dot{\theta}_z \theta_{Gk} >] \\
& + \frac{(R-e)^2}{2} [e < -\mu R (\theta_{Gk} + \phi_k) > + \lambda_k R \mu R \\
& \quad - \mu R < e (\theta_{Gk} + \phi_k) + \mu R \theta_y - \dot{R}_z > \\
& \quad - \mu R b (\dot{\theta}_{Gk} + \dot{\phi}_k)]] \\
& + \cos \psi_k \sin \psi_k [\frac{(R-e)^3}{3} \mu R \dot{\theta}_y \\
& + \frac{(R-e)^2}{2} [-\mu R < \mu R (\beta_p + \beta_k) + \theta_{Gk} (-\mu R \zeta_k - \dot{R}_y - \mu R \theta_z) \\
& \quad - \mu R \zeta_k \phi_k > \\
& + \mu R \zeta_k \mu R (\theta_{Gk} + \phi_k) - \mu R \theta_{Gk} < -\mu R \theta_z - \dot{R}_y >]] \\
& + \cos^2 \psi_k [-\frac{(R-e)^2}{2} \mu^2 R^2 \zeta_k (\beta_p + \beta_k)]
\end{aligned}$$

$$\begin{aligned}
& + \lambda_k R < \theta_{Gk} + \phi_k - \dot{\beta}_k + \zeta_k (\theta_{Gk} + \phi_k) - \zeta_k (\beta_p + \beta_k) + \dot{\theta}_z \theta_{Gk} > \\
& \quad + (-\mu R \dot{\theta}_y + \dot{R}_z) < \theta_{Gk} + \phi_k - \dot{\beta}_k + \zeta_k \theta_{Gk} > \\
& \quad + \zeta_k (\beta_p + \beta_k) < -\lambda_k R > + \dot{\beta}_k b (\dot{\theta}_{Gk} + \dot{\phi}_k)] \\
& + \frac{(R-e)^2}{2} [-\lambda_k R < -\lambda_k R + e(\theta_{Gk} + \phi_k) + \mu R \dot{\theta}_y - \dot{R}_z > \\
& \quad + (\mu R \dot{\theta}_y - \dot{R}_z) < -\lambda_k R + e\theta_{Gk} + \mu R \dot{\theta}_y - \dot{R}_z > \\
& \quad \quad \quad - \lambda_k R b (\dot{\theta}_{Gk} + \dot{\phi}_k)] \\
& - \cos \psi_k [\frac{2c_{do}}{a} [\frac{(R-e)^3}{3} < \mu R \zeta_k + \mu R \dot{\theta}_z + \dot{R}_y >] \\
& - \frac{(R-e)^4}{4} [-\dot{\beta}_k \dot{\theta}_y - \zeta_k \dot{\theta}_x \theta_{Gk} + \dot{\theta}_y < \theta_{Gk} + \phi_k - \dot{\beta}_k > + \zeta_k \theta_{Gk} \dot{\theta}_y] \\
& - \frac{(R-e)^3}{3} [\dot{\beta}_k < \mu R (\beta_p + \beta_k) + \theta_{Gk} (-\mu R \zeta_k - \mu R \dot{\theta}_z - \dot{R}_y) - \phi_k \mu R \zeta_k > \\
& + (\lambda_k R - \mu R \dot{\theta}_y + \dot{R}_z) (-\dot{\theta}_y) + \zeta_k (\beta_p + \beta_k) \mu R (\beta_p + \beta_k) \\
& \quad - \theta_{Gk} < -e\dot{\theta}_y + (\beta_p + \beta_k) (\mu R - \dot{R}_x) > \\
& \quad + (-\phi_k + \dot{\beta}_k) \mu R (\beta_p + \beta_k) - \lambda_k R \dot{\theta}_y \\
& \quad - \zeta_k (\theta_{Gk} + \phi_k) \mu R (\beta_p + \beta_k) \\
& \quad + \dot{\theta}_y (e\theta_{Gk} + \mu R \dot{\theta}_y - \dot{R}_z) \\
& \quad + (\dot{\theta}_z \theta_{Gk} - \zeta_k (\beta_p + \beta_k)) < -\mu R (\beta_p + \beta_k) >] \\
& + \frac{(R-e)^2}{2} [-\lambda_k R < \mu R (\beta_p + \beta_k) + \theta_{Gk} (-\mu R \zeta_k - \mu R \dot{\theta}_z - \dot{R}_y) \\
& \quad \quad \quad - \mu R \zeta_k \phi_k >
\end{aligned}$$

$$\begin{aligned}
& + (\mu R \dot{\theta}_y - \dot{R}_z) < \mu R (\beta_p + \beta_k) - \mu R \zeta_k \dot{\theta}_{Gk} > \\
& \quad - \lambda_k R \mu R (\beta_p + \beta_k) \\
& + (e (\theta_{Gk} + \phi_k) + \mu R \dot{\theta}_y - \dot{R}_z) \mu R (\beta_p + \beta_k) \\
& + \mu R (\beta_p + \beta_k) b (\dot{\theta}_{Gk} + \dot{\phi}_k)]] \\
& - \sin \psi_k \left[\frac{2c_{do}}{a} \left[\frac{(R-e)^3}{3} < \mu R (1 + \dot{\zeta}_k + \dot{\theta}_z) - \dot{R}_x > + \frac{(R-e)^2}{2} e \mu R \right] \right. \\
& - \frac{(R-e)^4}{4} [\beta_k \ddot{\theta}_x - \theta_{Gk} \zeta_k \ddot{\theta}_y - \dot{\theta}_x < \theta_{Gk} + \phi_k - \beta_k > - \theta_{Gk} \zeta_k \ddot{\theta}_x] \\
& \quad - \frac{(R-e)^3}{3} [\dot{\beta}_k < -\mu R (\theta_{Gk} + \phi_k) + \theta_{Gk} \dot{R}_x > \\
& + \dot{\theta}_x (\lambda_k R - \mu R \dot{\theta}_y + \dot{R}_z) + \zeta_k (\beta_p + \beta_k) < -\mu R (\theta_{Gk} + \phi_k) > \\
& - \theta_{Gk} < e \dot{\theta}_x + (\beta_p + \beta_k) (-\mu R \dot{\theta}_z - \dot{R}_y) > + \lambda_k R \dot{\theta}_x \\
& \quad - \dot{\theta}_x (e \theta_{Gk} + \mu R \dot{\theta}_y - \dot{R}_z)] \\
& + \frac{(R-e)^2}{2} [- \lambda_k R < -\mu R (\theta_{Gk} + \phi_k) + \theta_{Gk} \dot{R}_x > \\
& \quad + (\mu R \dot{\theta}_y - \dot{R}_z) < -\mu R (\theta_{Gk} + \phi_k) >]] \\
& + \cos \psi_k \sin \psi_k \left[- \frac{2c_{do}}{a} \frac{(R-e)^2}{2} [\mu R < \mu R \zeta_k + \mu R \dot{\theta}_z + \dot{R}_y >] \right. \\
& \quad \left. - \frac{(R-e)^4}{4} 2 \ddot{\theta}_y \ddot{\theta}_x \right. \\
& - \frac{(R-e)^3}{3} [- 2 \dot{\theta}_x < \mu R (\beta_p + \beta_k) - \mu R \zeta_k \dot{\theta}_{Gk} > \\
& \quad \left. + \dot{\theta}_y < -\mu R (\theta_{Gk} + \phi_k) >] \right]
\end{aligned}$$

$$\begin{aligned}
& + \frac{(R-e)^2}{2} [\mu R \theta_{Gk} \dot{e} \theta_y - \mu^2 R^2 (\beta_p + \beta_k) (\dot{\theta}_{Gk} + \dot{\phi}_k) \\
& \quad - 2\mu R \theta_{Gk} \dot{R}_x (\beta_p + \beta_k)]] \\
& + \cos^2 \psi_k [\frac{(R-e)^4}{4} \dot{\theta}_y^2 - \frac{(R-e)^3}{3} [2\dot{\theta}_y (\beta_p + \beta_k) \mu R - \mu R \zeta_k \dot{\theta}_{Gk} \dot{\theta}_y] \\
& \quad + \frac{(R-e)^2}{2} [\mu^2 R^2 (\beta_p + \beta_k)^2 \\
& \quad + \mu R (\beta_p + \beta_k) < -\mu R \zeta_k (\dot{\theta}_{Gk} + \dot{\phi}_k) + \dot{\theta}_{Gk} (-\dot{R}_y - \mu R \dot{\theta}_z) >]] \\
& + \sin^2 \psi_k [\frac{(R-e)^4}{4} \dot{\theta}_x^2 + \frac{(R-e)^3}{3} [-\mu R \theta_{Gk} (\dot{\theta}_x + \zeta_k \dot{\theta}_y) - \mu R \dot{\phi}_k \dot{\theta}_x] \\
& \quad + \frac{(R-e)^2}{2} [-\mu R \theta_{Gk} < \dot{e} \theta_x + (\beta_p + \beta_k) (-\mu R \dot{\theta}_z - \dot{R}_y) > \\
& \quad \quad - \frac{c_{d0}}{a} < \mu^2 R^2 - 2\mu R \dot{R}_x >]]] \\
- \frac{1}{2} \rho_A a b^2 \Omega^2 \{ & - \frac{(R-e)^3}{3} [< \ddot{\beta}_k - (\dot{\theta}_{Gk} + \dot{\phi}_k) > (\sin \theta_{Gk} + \phi_k \cos \theta_{Gk}) \\
& \quad - \zeta_k \dot{\theta}_{Gk} \sin \theta_{Gk}] \\
& + \frac{(R-e)^2}{2} \sin \theta_{Gk} (\mu R \ddot{\theta}_y - \ddot{R}_z) \\
& - \cos \psi_k [- \frac{(R-e)^3}{3} (\ddot{\theta}_y - \dot{\theta}_x) \sin \theta_{Gk} \\
& + \frac{(R-e)^2}{2} [(\mu R \ddot{\beta}_k - \mu R (\dot{\theta}_{Gk} + \dot{\phi}_k)) (\sin \theta_{Gk} + \phi_k \cos \theta_{Gk}) \\
& \quad - \mu R \zeta_k \dot{\theta}_{Gk} \sin \theta_{Gk}] \\
& - \sin \psi_k [\frac{(R-e)^3}{3} (\ddot{\theta}_x + \dot{\theta}_y) \sin \theta_{Gk} \\
& + \frac{(R-e)^2}{2} [- (\mu R (\beta_p + \beta_k) + \mu R (\dot{\theta}_{Gk} + \dot{\phi}_k)) \\
& \quad (\sin \theta_{Gk} + \phi_k \cos \theta_{Gk}) \\
& \quad + \mu R \zeta_k \dot{\theta}_{Gk} \sin \theta_{Gk}]]] \}
\end{aligned}$$

$$\begin{aligned}
& + \rho_A a b \Omega^2 \beta_k \zeta_k \left\{ \frac{(R-e)^4}{4} (\theta_{Gk} + \phi_k - \dot{\beta}_k) + \frac{(R-e)^3}{3} (-\lambda_k R) \right. \\
& \qquad \qquad \qquad \left. - \cos \psi_k \left[\frac{(R-e)^3}{3} \mu R (\beta_p + \beta_k) \right] \right. \\
& - \sin \psi_k \left[\frac{(R-e)^3}{3} [-2\mu R (\theta_{Gk} + \phi_k) + \mu R \dot{\beta}_k] + \frac{(R-e)^2}{2} \lambda_k R \mu R \right] \\
& \qquad \qquad \qquad + \cos \psi_k \sin \psi_k \left[-\frac{(R-e)^2}{2} \mu^2 R^2 (\beta_p + \beta_k) \right] \\
& \qquad \qquad \qquad \left. + \sin^2 \psi_k \left[\frac{(R-e)^2}{2} \mu^2 R^2 (\theta_{Gk} + \phi_k) \right] \right\}
\end{aligned}
\tag{5.100}$$

The orders of magnitude of the leading terms in the various aerodynamic loads are given for convenience

$$\begin{aligned}
P_{A_{x3k}} &= O(\epsilon^{3/2}) \\
P_{A_{y3k}} &= O(\epsilon^{3/2}) \\
P_{A_{z3k}} &= O(\epsilon^{1/2}) \\
Q_{A_{x3k}} &= O(\epsilon^{3/2}) \\
Q_{A_{y3k}} &= O(\epsilon^{1/2}) \\
Q_{A_{z3k}} &= O(\epsilon^{3/2})
\end{aligned}$$

Damping Force

Instead of assuming a distributed damping force representing the structural damping of the blade, one can assume a damping force proportional to the velocity and it is provided at the root of the blade. It can be written as

$$\text{Flap} \quad Q_{D_{y3k}} = + \Omega \dot{\beta}_k g_{S_F} \quad (5.101)$$

$$\text{Lead-lag} \quad Q_{D_{z3k}} = - \Omega \dot{\zeta}_k g_{S_L} \quad (5.102)$$

$$\text{Torsion} \quad Q_{D_{x3k}} = - \Omega \dot{\phi}_k g_{S_T} \quad (5.103)$$

These damping forces are proportional to the rate of change in angles in flap, lead-lag and torsion. Reason for this type of assumption is that in the present study the blade is modeled as a rigid blade with root springs.

Equations of Motion

Using the moment equilibrium condition at the blade root, the equations of motion for the k^{th} blade can be written as follows.

Flap: The flap equation is

$$M_{\beta_k} + Q_{I_{y3k}} + Q_{A_{y3k}} + Q_{D_{y3k}} = 0 \quad (5.104)$$

Lead-lag: The lead-lag equation is

$$M_{\zeta_k} + Q_{I_{z3k}} + Q_{A_{z3k}} + Q_{D_{z3k}} = 0 \quad (5.105)$$

Torsion: The torsion equation is

$$M_{\phi_k} + Q_{I_{x3k}} + Q_{A_{x3k}} + Q_{D_{x3k}} = 0 \quad (5.106)$$

The elastic restoring moments due to the root springs are given in Appendix. The results are summarized below.

$$M_{\beta_k} = \frac{(\beta_k - \phi_k \zeta_k)}{\Delta} \left\{ K_{\beta} + R_1 (K_{\zeta} - K_{\beta}) \sin^2 \theta_{Gk} \right\} + \frac{(\zeta_k + \phi_k \beta_k)}{\Delta} R_1 (K_{\zeta} - K_{\beta}) \sin \theta_{Gk} \cos \theta_{Gk}$$

$$M_{\zeta_k} = - \frac{(\zeta_k + \phi_k \beta_k)}{\Delta} \left\{ K_{\zeta} - R_1 (K_{\zeta} - K_{\beta}) \sin^2 \theta_{Gk} \right\} - \frac{(\beta_k - \phi_k \zeta_k)}{\Delta} R_1 (K_{\zeta} - K_{\beta}) \sin \theta_{Gk} \cos \theta_{Gk}$$

$$M_{\phi_k} = -K_{\phi_1} (\phi_k - \zeta_k \beta_k) - K_{\phi_2} \phi_k$$

where

$$K_{\beta} = \frac{K_{\beta_H} K_{\beta_B}}{K_{\beta_H} + K_{\beta_B}} \quad ; \quad K_{\zeta} = \frac{K_{\zeta_H} K_{\zeta_B}}{K_{\zeta_H} + K_{\zeta_B}}$$

$$R_1 = \frac{1/K_{\beta_B} - 1/K_{\zeta_B}}{(1/K_{\beta_B} + 1/K_{\beta_H}) - (1/K_{\zeta_B} + 1/K_{\zeta_H})}$$

$$\Delta' = 1 + R_1 (1-R_1) \sin^2 \theta_{Gk} (K_{\zeta} - K_{\beta})^2 / K_{\zeta} K_{\beta}$$

For an articulated blade

$$K_{\beta} = K_{\zeta} = K_{\phi_1} = 0 \quad \text{and} \quad K_{\phi_2} = \frac{K_{\phi_C} K_{\phi_B}}{K_{\phi_C} + K_{\phi_B}}$$

For a hingeless blade

$$K_{\phi_2} = 0 \quad \text{and} \quad K_{\phi_1} = \frac{K_{\phi_C} K_{\phi_B}}{K_{\phi_C} + K_{\phi_B}}$$

6. EQUATIONS OF MOTION OF THE SUPPORTING STRUCTURE

6.1 General

The supporting structure, to which the envelope and the rotors of the HHLA vehicle modeled in this study (Fig. 2) are attached, is assumed to be flexible. The degrees of freedom associated with the supporting structure consist therefore of both rigid body and flexible degrees of freedom. The structure is idealized as a free-free beam and is represented by relatively few number of bending and torsional free vibration modes. The derivation of the equations of motion consists of two parts.

- 1) One part representing the rigid body degrees of freedom.
- 2) A second part representing the flexible modes of the structure.

In dealing with these two contributions to the total motion it is assumed that rigid body motions occur first. After establishing a perturbed state, consisting of rigid body translation and rotation, the elastic deformations are superposed. Thus the equations representing the rigid body degrees of freedom are written in S-system and the equations of motion representing the elastic structure are written in S1-system, see Figs. 8 and 9. To write the equations, various external loads have to be identified and properly transformed to the corresponding coordinate systems.

6.2 Loads

The various external loads acting on the model are illustrated in Fig. 12.

1. The rotor loads at hub center O_{H1} and O_{H2} .
2. Aerodynamic loads on the envelope acting at the center of buoyancy O_C and a static buoyant lift.
3. Thruster loads acting at O_{F1} and O_{F2} .
4. Gravity loads acting at the respective center of mass of underslung weight, envelope weight, fuselages weight and the supporting structure weight. The respective center of mass locations are denoted by O_{UN} , O_{EN} , O_{F1} , O_{F2} , O_S .

6.2.1 Rotor Loads

The loads acting on the rotor blades are inertia and the aerodynamic loads. These distributed loads are transformed into forces and moments acting at the blade root. The moments are balanced by root springs and dampers. The loads

on the k^{th} blade are derived in Chapter 5 and are given in 3k coordinate system. They are given in equations (5.89)-(5.100). Net combined loads acting at the root of the blade are

$$\bar{P}_{3k} = \bar{P}_{I3k} + \bar{P}_{A3k} \quad (6.1)$$

$$\bar{Q}_{3k} = \bar{Q}_{I3k} + \bar{Q}_{A3k} + \bar{Q}_{D3k} \quad (6.2)$$

These loads are transformed into loads acting parallel to 2k system, using the following transformation.

$$\bar{P}_{2k3} = [T_{23}] \bar{P}_{3k} \quad (6.3)$$

$$\bar{Q}_{2k3} = [T_{23}] \bar{Q}_{3k} \quad (6.4)$$

where \bar{P}_{2k3} and \bar{Q}_{2k3} are forces and moments acting at the blade root (i.e. origin of the 3k system) whose components are given in 2k system. Transforming these loads into loads acting at the origin of the 2k system (i.e. hub center, either O_{H1} or O_{H2})

$$\bar{P}_{2k} = \bar{P}_{2k3} \quad (6.5)$$

$$\bar{Q}_{2k} = \bar{Q}_{2k3} + (e \hat{e}_{x2k} \times \bar{P}_{2k3}) \quad (6.6)$$

$$\bar{P}_{2k} = (P_{x3k} - \beta_p P_{z3k}) \hat{e}_{x2k} + P_{y3k} \hat{e}_{y2k} + (P_{z3k} + \beta_p P_{x3k}) \hat{e}_{z2k} \quad (6.7)$$

$$\begin{aligned} \bar{Q}_{2k} = & (Q_{x3k} - \beta_p Q_{z3k}) \hat{e}_{x2k} + Q_{y3k} \hat{e}_{y2k} + (Q_{z3k} + \beta_p Q_{x3k}) \hat{e}_{z2k} \\ & + [-e (P_{z3k} + \beta_p P_{x3k}) \hat{e}_{y2k} + e P_{y3k} \hat{e}_{z2k}] \quad (6.8) \end{aligned}$$

Again transforming these loads to 1 system

$$\bar{P}_{1k} = [T_{12}] \bar{P}_{2k} \quad (6.9)$$

$$\bar{Q}_{1k} = [T_{12}] \bar{Q}_{2k} \quad (6.10)$$

Expanding

$$\begin{aligned}
\bar{P}_{1k} = & [\cos\psi_k \langle P_{x3k} - \beta_p P_{z3k} \rangle - \sin\psi_k P_{y3k}] \hat{e}_{x1} \\
& + [\sin\psi_k \langle P_{x3k} - \beta_p P_{z3k} \rangle + \cos\psi_k P_{y3k}] \hat{e}_{y1} \\
& + [P_{z3k} + \beta_p P_{x3k}] \hat{e}_{z1} \quad (6.11)
\end{aligned}$$

$$\begin{aligned}
\bar{Q}_{1k} = & \hat{e}_{x1} [\cos\psi_k \langle Q_{x3k} - \beta_p Q_{z3k} \rangle - \sin\psi_k \langle Q_{y3k} - e(P_{z3k} + \beta_p P_{x3k}) \rangle] \\
& + \hat{e}_{y1} [\sin\psi_k \langle Q_{x3k} - \beta_p Q_{z3k} \rangle + \cos\psi_k \langle Q_{y3k} - e(P_{z3k} + \beta_p P_{x3k}) \rangle] \\
& + \hat{e}_{z1} [Q_{z3k} + \beta_p Q_{x3k} + e P_{y3k}] \quad (6.12)
\end{aligned}$$

These loads are acting origin of the 1 system i.e. either at O_{H1} or O_{H2} depending on the rotor system. Total load due to all the blades in the two rotor systems are

$$\underline{\text{Rotor System 1}} \quad \bar{P}_{1H1} = \sum_{k=1}^N \bar{P}_{1k} \quad (6.13)$$

$$\bar{Q}_{1H1} = \sum_{k=1}^N \bar{Q}_{1k} \quad (6.14)$$

$$\underline{\text{Rotor System 2}} \quad \bar{P}_{1H2} = \sum_{k=1}^N \bar{P}_{1k} \quad (6.15)$$

$$\bar{Q}_{1H2} = \sum_{k=1}^N \bar{Q}_{1k} \quad (6.16)$$

The summation is over the number of blades in the individual rotor systems. As it was pointed out earlier that \bar{P}_{1k} and \bar{Q}_{1k} will be different for different blades and also for different rotor systems.

Transforming the loads acting at O_{H1} to the point O_{F1} (C.G. of fuselage F1) and that at O_{H2} to the point O_{F2} (C.G. of fuselage F2),

$$\bar{P}_{1F1} = \bar{P}_{1H1} \quad (6.17)$$

$$\begin{aligned} \bar{Q}_{1F1} &= \bar{Q}_{1H1} + (h_2 \hat{e}_{zs1} \times \bar{P}_{1H1}) \\ &= \bar{Q}_{1H1} + [-h_2 P_{y1H1} \hat{e}_{xs1} + h_2 P_{x1H1} \hat{e}_{ys1}] \end{aligned} \quad (6.18)$$

where P_{y1H1} is the y-component of the vector \bar{P}_{1H1} and P_{x1H1} is the x-component of the vector \bar{P}_{1H1} . It should be noted that according to our initial assumption the 1 system and the S1 system are assumed to be parallel. Similarly for the second rotor system

$$\bar{P}_{1F2} = \bar{P}_{1H2} \quad (6.19)$$

$$\begin{aligned} \bar{Q}_{1F2} &= \bar{Q}_{1H2} + (h_2 \hat{e}_{zs1} \times \bar{P}_{1H2}) \\ &= \bar{Q}_{1H2} + [-h_2 P_{y1H2} \hat{e}_{xs1} + h_2 P_{x1H2} \hat{e}_{ys1}] \end{aligned} \quad (6.20)$$

The loads presented in equations (6.17)-(6.20) are acting at the points O_{F1} and O_{F2} . The components of these loads are given in 1 system (S1 system), both the 1 system and S1 system are parallel systems. The components of these loads will be used in writing the equations of motion representing the elastic modes of the supporting structure. Writing these loads in terms of loads in the 3k system

$$\begin{aligned} \bar{P}_{1F1} &= \sum_{k=1}^N \{ \hat{e}_{x1} [\cos\psi_k \langle P_{x3k} - \beta_p P_{z3k} \rangle - \sin\psi_k P_{y3k}] \\ &\quad + \hat{e}_{y1} [\sin\psi_k \langle P_{x3k} - \beta_p P_{z3k} \rangle + \cos\psi_k P_{y3k}] \\ &\quad + \hat{e}_{z1} [P_{z3k} + \beta_p P_{x3k}] \} \end{aligned} \quad (6.21)$$

$$\begin{aligned} \bar{Q}_{1F1} &= \sum_{k=1}^N \{ \hat{e}_{x1} [\cos\psi_k \langle Q_{x3k} - \beta_p Q_{z3k} \rangle - \sin\psi_k \langle Q_{y3k} \\ &\quad - e (P_{z3k} + \beta_p P_{x3k}) \rangle \\ &\quad - h_2 (\sin\psi_k \langle P_{x3k} - \beta_p P_{z3k} \rangle + \cos\psi_k P_{y3k}) \} \end{aligned}$$

$$\begin{aligned}
& + \hat{e}_{y1} [\sin\psi_k \langle Q_{x3k} - \beta_p Q_{z3k} \rangle + \cos\psi_k \langle Q_{y3k} \\
& \qquad \qquad \qquad - e(P_{z3k} + \beta_p P_{x3k}) \rangle \\
& \qquad \qquad \qquad + h_2 (\cos\psi_k \langle P_{x3k} - \beta_p P_{z3k} \rangle \\
& \qquad \qquad \qquad - \sin\psi_k P_{y3k})] \\
& + \hat{e}_{z1} [Q_{z3k} + \beta_p Q_{x3k} + e P_{y3k}] \} \qquad (6.22)
\end{aligned}$$

The expressions \bar{P}_{1F1} and \bar{Q}_{1F1} represent the forces and moments due to rotor systems R1. These loads act at the point O_{F1} on the supporting structure. Similarly, the loads due to the rotor system R2 are \bar{P}_{1F2} and \bar{Q}_{1F2} . These loads act at this point O_{F2} on the supporting structure. Since the rotor loads are derived for a general rotor system, the expressions for these loads given in equations (6.21) and (6.22) are valid for both rotor systems R1 and R2. However the components P_{x3k} , P_{y3k} , P_{z3k} , Q_{x3k} , Q_{y3k} , Q_{z3k} could be different for the two rotor systems depending on the operating conditions and various other rotor parameters.

The rotor loads \bar{P}_{1F1} , \bar{Q}_{1F1} , \bar{P}_{1F2} , \bar{Q}_{1F2} will be used in writing the equations of motion of the vehicle and the supporting structure. Hence, it is convenient to refer these loads in the body fixed S1 coordinate system. From equations (6.21) and (6.22) it can be seen that these rotor loads are given as components along the hub fixed l system. By definition, the hub fixed l system and the body fixed S1 system are parallel. Therefore in subsequent parts of this report these rotor loads will be referred as \bar{P}_{S1F1} for \bar{P}_{1F1} , \bar{Q}_{S1F1} for \bar{Q}_{1F1} , \bar{P}_{S1F2} for \bar{P}_{1F2} and \bar{Q}_{S1F2} for \bar{Q}_{1F2} . Again these loads are transformed into components along the S system acting at point O_S on the structure. Finally the individual rotor loads are added together to get the total rotor loads. The total rotor loads at O_S are (components along S system)

$$\bar{P}_{SR} = [T_{S,S1}] \bar{P}_{S1F1} + [T_{S,S1}] \bar{P}_{S1F2} \qquad (6.23)$$

$$\begin{aligned} \bar{Q}_{SR} = [T_{S,S1}] [\bar{Q}_{S1F1} - l_{F1} \hat{e}_{xS1} \times \bar{P}_{S1F1}] \\ + [T_{S,S1}] [\bar{Q}_{S1F2} + l_{F2} \hat{e}_{xS1} \times \bar{P}_{S1F2}] \quad (6.24) \end{aligned}$$

where $[T_{S,S1}]$ is the transformation matrix relating the body fixed noninertial S1 system to inertial S system.

$$[T_{S,S1}] = \begin{bmatrix} 1 & \theta_y \theta_x - \theta_z & \theta_z \theta_x + \theta_y \\ \theta_z & 1 & \theta_z \theta_y - \theta_x \\ -\theta_y & \theta_x & 1 \end{bmatrix}$$

where $\theta_x, \theta_y, \theta_z$ represent the Euler angles for rigid body rotation.

6.2.2 Aerodynamic Loads Due to the Envelope

The aerodynamic loads of the envelope are the buoyancy loads acting along the body axes. These are denoted respectively by \bar{P}_{EN} and \bar{Q}_{EN} .

$$\begin{aligned} \bar{P}_{EN} &= P_x \hat{e}_{xS1} + P_y \hat{e}_{yS1} + P_z \hat{e}_{zS1} + P_z^S \hat{e}_{zS} \\ &= (P_x - \theta_y P_z^S) \hat{e}_{xS1} + (P_y + \theta_x P_z^S) \hat{e}_{yS1} + (P_z + P_z^S) \hat{e}_{zS} \end{aligned} \quad (6.25)$$

$$\bar{Q}_{EN} = Q_x \hat{e}_{xS1} + Q_y \hat{e}_{yS1} + Q_z \hat{e}_{zS1} \quad (6.26)$$

These loads act at the center of buoyancy O_C . The components of the dynamic loads are defined as [Ref. 7]

$$\text{Forces} \quad P_x = C_x q V^{2/3}, \quad P_y = C_y q V^{2/3}, \quad P_z = C_z q V^{2/3} \quad (6.27)$$

$$\text{Moments} \quad Q_x = C_l q V, \quad Q_y = C_m q V, \quad Q_z = C_n q V \quad (6.28)$$

Where V is the volume of the envelope

q is the dynamic pressure

P_z^S is the static lift on the envelope acting along Z_s axis

and $c_{x, y, z, \ell, m, n}$ are coefficients

Transforming these loads to the point O_S on the supporting structure

$$\bar{P}_{S1EN} = \bar{P}_{EN} \quad (6.29)$$

$$\begin{aligned} \bar{Q}_{S1EN} &= \bar{Q}_{EN} + (h_3 \hat{e}_{zsl} \times \bar{P}_{EN}) \\ &= \bar{Q}_{EN} + [-h_3 (P_y + \theta_x P_z^S) \hat{e}_{xsl} + h_3 (P_x - \theta_y P_z^S) \hat{e}_{ysl}] \end{aligned} \quad (6.30)$$

Expanding

$$\begin{aligned} \bar{P}_{S1EN} &= (C_x q V^{2/3} - \theta_y P_z^S) \hat{e}_{xsl} + (C_y q V^{2/3} + \theta_x P_z^S) \hat{e}_{ysl} \\ &\quad + (C_z q V^{2/3} + P_z^S) \hat{e}_{zsl} \end{aligned} \quad (6.31)$$

$$\begin{aligned} \bar{Q}_{S1EN} &= (C_\ell q V - h_3 C_y q V^{2/3} - h_3 \theta_x P_z^S) \hat{e}_{xsl} \\ &\quad + (C_m q V + h_3 C_x q V^{2/3} - \theta_y P_z^S) \hat{e}_{ysl} \\ &\quad + C_n q V \hat{e}_{zsl} \end{aligned} \quad (6.32)$$

Writing these loads, along the S system, acting at O_S

$$\bar{P}_{SEN} = [T_{S,S1}] \bar{P}_{S1EN} \quad (6.33)$$

$$\bar{Q}_{SEN} = [T_{S,S1}] \bar{Q}_{S1EN} \quad (6.34)$$

6.2.3 Thruster Loads

Two thrusters simulated by thruster forces are assumed to act at the C.G. of the fuselages F1 and F2 i.e. O_{F1} and O_{F2} . They are

$$\bar{P}_{TF1} = -\bar{P}_T \hat{e}_{xsl} \quad \text{and} \quad \bar{P}_{TF2} = -\bar{P}_T \hat{e}_{xsl} \quad (6.35)$$

Transforming these forces to the C.G. of the structure O_S and combining them

$$\bar{P}_{S1T} = -2 P_T \hat{e}_{xsl} \quad (6.36)$$

in the S coordinate system

$$\bar{P}_{ST} = [T_{S,S1}] \bar{P}_{S1T} \quad (6.37)$$

6.2.4 Gravity Loads

The gravity loads are due to the various masses which constitute the HHLA model. These loads act along $-\hat{e}_{zs}$ direction, at the respective centers of mass. The various contributions are:

Fuselage

The gravity loads on the two fuselages act at O_{F1} and O_{F2} . These are

$$\bar{P}_{WF1} = -W_{F1} \hat{e}_{zs} \quad (6.38)$$

$$\bar{P}_{WF2} = -W_{F2} \hat{e}_{zs} \quad (6.39)$$

Transforming these loads to the point O_S on the structure and adding them

$$\bar{P}_{SWF} = -(W_{F1} + W_{F2}) \hat{e}_{zs} \quad (6.40)$$

$$\bar{Q}_{SWF} = -l_{F1} \hat{e}_{xs1} \times \bar{P}_{WF1} + l_{F2} \hat{e}_{xs1} \times \bar{P}_{WF2}$$

where \bar{P}_{SWF} is the gravity force

\bar{Q}_{SWF} is the moment at O_S due to the gravity forces.

$$\begin{aligned} \bar{Q}_{SWF} &= (-l_{F1} \hat{e}_{xs} - \theta_z l_{F1} \hat{e}_{ys} + \theta_y l_{F1} \hat{e}_{zs}) \times (-W_{F1} \hat{e}_{zs}) \\ &\quad + (l_{F2} \hat{e}_{xs} + \theta_z l_{F2} \hat{e}_{ys} - \theta_y l_{F2} \hat{e}_{zs}) \times (-W_{F2} \hat{e}_{zs}) \\ &= (\theta_z l_{F1} W_{F1} - \theta_z l_{F2} W_{F2}) \hat{e}_{xs} \\ &\quad + (-l_{F1} W_{F1} + l_{F2} W_{F2}) \hat{e}_{ys} \end{aligned} \quad (6.41)$$

Underslung Weight

It is assumed that the underslung mass is rigidly attached to the supporting structure. The gravity force on this mass acts at its C.G. O_{UN} at a distance $-h_1 \hat{e}_{zs1}$ from O_S .

The loads due to this mass at O_S (in S system) are

$$\bar{P}_{SWUN} = -W_{UN} \hat{e}_{zs} \quad (6.42)$$

$$\begin{aligned} \bar{Q}_{SWUN} &= -h_1 \hat{e}_{zsl} \times (-W_{UN} \hat{e}_{zs}) \\ &= (-h_1(\theta_z \theta_x + \theta_y) \hat{e}_{xs} - h_1(\theta_z \theta_y - \theta_x) \hat{e}_{ys} - h_1 \hat{e}_{zs}) \times (-W_{UN} \hat{e}_{zs}) \\ &= h_1 (\theta_z \theta_y - \theta_x) W_{UN} \hat{e}_{xs} - h_1 (\theta_z \theta_x + \theta_y) W_{UN} \hat{e}_{ys} \quad (6.43) \end{aligned}$$

Envelope Weight

The gravity load on the envelope acting at its C.G., O_{EN} is $-W_{EN} \hat{e}_{zs}$. It is located at a distance $h_4 \hat{e}_{zsl}$ from O_S . Transforming this load to the point O_S on the structure,

$$\bar{P}_{SWEN} = -W_{EN} \hat{e}_{zs} \quad (6.44)$$

$$\begin{aligned} \bar{Q}_{SWEN} &= h_4 \hat{e}_{zsl} \times (-W_{EN} \hat{e}_{zs}) \\ &= [h_4 (\theta_z \theta_x + \theta_y) \hat{e}_{xs} + h_4 (\theta_z \theta_y - \theta_x) \hat{e}_{ys} + h_4 \hat{e}_{zs}] \times \\ &\quad (-W_{EN} \hat{e}_{zs}) \\ &= -h_4 (\theta_z \theta_y - \theta_x) W_{EN} \hat{e}_{xs} + h_4 (\theta_z \theta_x + \theta_y) W_{EN} \hat{e}_{ys} \quad (6.45) \end{aligned}$$

Supporting Structure Weight

The gravity force on the supporting structure is acting at its C.G., O_S , in $-\hat{e}_{zs}$ direction, it is given by

$$P_{SWS} = -W_S \hat{e}_{zs} \quad (6.46)$$

$$\begin{aligned} \bar{Q}_{SWS} &= h_5 \hat{e}_{xsl} \times (-W_S \hat{e}_{zs}) \\ &= (h_5 \hat{e}_{xs} + \theta_z h_5 \hat{e}_{ys} - \theta_y h_5 \hat{e}_{zs}) \times (-W_S \hat{e}_{zs}) \\ &= (-\theta_z h_5 W_S \hat{e}_{xs} + h_5 W_S \hat{e}_{ys}) \quad (6.47) \end{aligned}$$

6.3 Rigid Body Equations of Motion

Using the various loads derived in S coordinate system, the rigid body translational and rotational equations of motion can be written in the S system.

Let the rigid body perturbational translational motion of the point O_S be

$$\bar{R}_S = R_{xs} \hat{e}_{xs} + R_{ys} \hat{e}_{ys} + R_{zs} \hat{e}_{zs} \quad (6.48)$$

Then the translational equations of motion become

$$\frac{W}{g} \ddot{\bar{R}}_S = \bar{P}_{SR} + \bar{P}_{SEN} + \bar{P}_{ST} + \bar{P}_{SWF} + \bar{P}_{SWUN} + \bar{P}_{SWEN} + \bar{P}_{SWS} \quad (6.49)$$

where $W = W_{EN} + W_{UN} + W_{F1} + W_{F2} + W_S$

W_S is the supporting structure weight.

The equations of motion for the rotational degrees of freedom are

$$\frac{d}{dt} [I \bar{\omega}] = \bar{Q}_{SR} + \bar{Q}_{SEN} + \bar{Q}_{SWF} + \bar{Q}_{SWUN} + \bar{Q}_{SWEN} + \bar{Q}_{SWS} \quad (6.50)$$

where $[I] = [T_{Sl,S}]^T [I_S + I_{F1} + I_{F2} + I_{EN} + I_{UN}] [T_{Sl,S}]$

and $\bar{\omega} = \Omega[(\dot{\theta}_x - \theta_z \dot{\theta}_y) \hat{e}_{xs} + (\dot{\theta}_y + \theta_z \dot{\theta}_x) \hat{e}_{ys} + (\dot{\theta}_z - \theta_y \dot{\theta}_x) \hat{e}_{zs}]$

The individual inertia tensors are given by

Structure:

$$[I_S] = \begin{bmatrix} I_{xx} & -I_{xy} & -I_{xz} \\ -I_{yx} & I_{yy} & -I_{yz} \\ -I_{zx} & -I_{zy} & I_{zz} \end{bmatrix} + \frac{W_S}{g} \begin{bmatrix} 0 & 0 & 0 \\ 0 & h_5^2 & 0 \\ 0 & 0 & h_5^2 \end{bmatrix} \quad S$$

Fuselage:

$$[I_{F1}] = \begin{bmatrix} I_{xx} & 0 & -I_{xz} \\ 0 & I_{yy} & 0 \\ -I_{xz} & 0 & I_{zz} \end{bmatrix} + \frac{W_{F1}}{g} \begin{bmatrix} 0 & 0 & 0 \\ 0 & l_{F1}^2 & 0 \\ 0 & 0 & l_{F1}^2 \end{bmatrix} \quad F1$$

$$[I_{F2}] = \begin{bmatrix} I_{xx} & 0 & -I_{xz} \\ 0 & I_{yy} & 0 \\ -I_{xz} & 0 & I_{zz} \end{bmatrix} + \frac{W_{F2}}{g} \begin{bmatrix} 0 & 0 & 0 \\ 0 & l_{F2}^2 & 0 \\ 0 & 0 & l_{F2}^2 \end{bmatrix}$$

The first matrix is defined about the body axes.

Envelope:

$$[I_{EN}] = \begin{bmatrix} I_{xx} & -I_{xy} & -I_{xz} \\ -I_{yx} & I_{yy} & -I_{yz} \\ -I_{zx} & -I_{zy} & I_{zz} \end{bmatrix} + \frac{W_{EN}}{g} \begin{bmatrix} h_4^2 & 0 & 0 \\ 0 & h_4^2 & 0 \\ 0 & 0 & 0 \end{bmatrix}$$

Underslung weight:

$$[I_{UN}] = \begin{bmatrix} I_{xx} & -I_{xy} & -I_{xz} \\ -I_{yx} & I_{yy} & -I_{yz} \\ -I_{zx} & -I_{zy} & I_{zz} \end{bmatrix} + \frac{W_{UN}}{g} \begin{bmatrix} h_1^2 & 0 & 0 \\ 0 & h_1^2 & 0 \\ 0 & 0 & 0 \end{bmatrix}$$

6.4 Equations of Motion for Elastic Modes

The flexible supporting structure is assumed to be a free-free beam idealized by a small number of modes of vibration. The structure can have bending vibration in the two planes and a torsional vibration about its longitudinal axis. These elastic modes are assumed to occur in S1 coordinate system, and therefore the equations of motion are written in S1 system. Furthermore the structure is assumed to vibrate about its equilibrium position. Bending in $x_{s1} - y_{s1}$ plane [Fig. 9]

The elastic deformation at any point on the structure due to the bending deformation is written as

$$v_s(x_{s1}) = \sum_{i=1}^{NM} \eta_i(x_{s1}) \xi_i(t) \quad (6.51)$$

where η_i is the mode shape, ξ_i is the generalized coordinate or normal coordinate and NM is the number of modes.

The equations of motion written, in normal coordinate, are

$$[M]\{\ddot{\xi}\} + [K]\{\xi\} = \{Q\} \quad (6.52)$$

Where $\{Q\}$ represents the generalized forces

$[M]$ is the generalized mass

$[K]$ is the generalized stiffness

It is assumed that these vibration modes are small compared to the rigid body perturbational motion. So there is no coupling between the vibration modes. The generalized forces are (force at a location x modal displacement at the same location or moment x slope of the modal displacement curve)

$$\begin{aligned} Q_i = & P_{yS1F1} \eta_i(l_{F1}) + Q_{zS1F1} \eta_{i,x}(l_{F1}) + P_{yS1WF1} \eta_i(l_{F1}) \\ & + P_{yS1F2} \eta_i(l_{F2}) + Q_{zS1F2} \eta_{i,x}(l_{F2}) + P_{yS1WF2} \eta_i(l_{F2}) \\ & + P_{yS1EN} \eta_i(0_S) + Q_{zS1EN} \eta_{i,x}(0_S) + [P_{yS1WEN} + P_{yS1WUN}] \eta_i(0_S) \\ & + \int_{-l_{F1}}^{l_{F2}} P_{yS1WS} \eta_i(x) dx \end{aligned}$$

Terms with suffix 'SlW' refer to gravity loads referred in Sl system. A typical element of the mass matrix and stiffness matrix are

$$\begin{aligned} M_{ii} = & \int_{-l_{F1}}^{l_{F2}} \eta_i m_s(x) \eta_i dx + \frac{W_{F1}}{g} \eta_i^2(l_{F1}) + I_{zz_{F1}} \eta_{i,x}^2(l_{F1}) \\ & + \frac{W_{F2}}{g} \eta_i^2(l_{F2}) + I_{zz_{F2}} \eta_{i,x}^2(l_{F2}) \\ & + \frac{W_{EN}}{g} \eta_i^2(0_S) + I_{zz_{EN}} \eta_{i,x}^2(0_S) \\ & + \frac{W_{UN}}{g} \eta_i^2(0_S) + I_{zz_{UN}} \eta_{i,x}^2(0_S) \end{aligned}$$

$$\text{and } K_{ii} = \omega_i^2 \int_{-l_{F1}}^{l_{F2}} \eta_i m_s(x) \eta_i dx$$

where ω_i is the i^{th} mode natural frequency of the supporting structure

m_s is the mass of the structure/unit length

Bending $x_{s1} - z_{s1}$ plane

The elastic deformation at any point is given by

$$w_s(x_{s1}) = \sum_{i=NM+1}^{NM1} \eta_i(x_{s1}) \xi_i(t) \quad (6.53)$$

The form equation of motion is similar to equation (6.46). The generalized forces are

$$\begin{aligned} Q_i = & P_{zS1F1} \eta_i(\ell_{F1}) + Q_{yS1F1} \eta_{i,x}(\ell_{F1}) + Q_{yS1WUN} \eta_{i,x}(0_S) \\ & + P_{zS1F2} \eta_i(\ell_{F2}) + Q_{yS1F2} \eta_{i,x}(\ell_{F2}) + Q_{yS1WEN} \eta_{i,x}(0_S) \\ & + P_{zS1EN} \eta_i(0_S) + Q_{yS1EN} \eta_{i,x}(0_S) \end{aligned}$$

Typical elements of the mass and stiffness matrix are

$$\begin{aligned} M_{ii} = & \int_{-\ell_{F2}}^{\ell_{F1}} \eta_i m_s(x) \eta_i dx + \frac{W_{F1}}{g} \eta_i^2(\ell_{F1}) + I_{yyF1} \eta_{i,x}^2(\ell_{F1}) \\ & + \frac{W_{F2}}{g} \eta_i^2(\ell_{F2}) + I_{yyF2} \eta_{i,x}^2(\ell_{F2}) \\ & + \frac{W_{EN}}{g} \eta_i^2(0_S) + I_{yyEN} \eta_{i,x}^2(0_S) \\ & + \frac{W_{EN}}{g} h_4^2 \eta_{i,x}^2(0_S) \\ & + \frac{W_{UN}}{g} \eta_i^2(0_S) + I_{yyUN} \eta_{i,x}^2(0_S) \\ & + \frac{W_{UN}}{g} h_1^2 \eta_{i,x}^2(0_S) \end{aligned}$$

and

$$K_{ii} = \omega_i^2 \int_{-\ell_{F2}}^{\ell_{F1}} \eta_i m_s(x) \eta_i dx$$

Torsion

The torsional vibration of the supporting structure is about x_{s1} axis [Fig. 9]. The twist at any section due to the torsional deformation is given by the normal modes $\eta_i(x)$ as

$$\phi_s(x_{s1}) = \sum_{i=NM1+1}^{NM2} \eta_i(x_{s1}) \xi_i(t) \quad (6.54)$$

The torsional vibration equation in normal mode is

$$[I] \ddot{\{\xi\}} + [K] \{\xi\} = \{Q\} \quad (6.55)$$

The generalized force Q_i 's are

$$Q_i = Q_{xS1F1} \eta_i(l_{F1}) + Q_{xS1F2} \eta_i(l_{F2}) + Q_{xS1EN} \eta_i(0_S) \\ + Q_{xS1WEN} \eta_i(0_S) + Q_{xS1WUN} \eta_i(0_S)$$

Typical members of $[I]$ and $[K]$ matrices are

$$I_{ii} = \int_{-l_{F1}}^{l_{F2}} \eta_i I_s(x) \eta_i dx + I_{xxF1} \eta_i^2(l_{F1}) + I_{xxF2} \eta_i^2(l_{F2}) \\ + I_{xxEN} \eta_i^2(0_S) + I_{xxUN} \eta_i^2(0_S) \\ + \frac{W_{EN}}{g} h_4^2 \eta_i^2(0_S) + \frac{W_{UN}}{g} h_1^2 \eta_i^2(0_S)$$

and

$$K_{ii} = \omega_i^2 \int_{-l_{F1}}^{l_{F2}} \eta_i I_s(x) \eta_i dx$$

where I_s is the moment of inertia of the structure per unit length about its longitudinal axis.

7. CONCLUDING REMARKS

A complete set of dynamical equations of motion for a simple model of HHLA were derived in this report. These equations can be used to study the stability of HHLA and to obtain the various response quantities at different stations on the vehicle. For convenience, the equation numbers are summarized below with the physical degree of freedom which it represents.

Blade equations

Flap	Equation (5.104)
Lead-Lag	Equation (5.105)
Torsion	Equation (5.106)

Supporting Structure equations

Rigid body translation	Equation (6.49)
Rigid body rotation	Equation (6.50)
Bending in x_{s1} - y_{s1} plane	Equation (6.52)
Bending in x_{s1} - z_{s1} plane	Equation (6.52)
Torsion about x_{s1} axis	Equation (6.55)

The coupled rotor/body equations of motion which have been derived in this study have considerable versatility and can be used to model a number of diverse rotary-wing configurations, which are listed below:

- (a) Isolated rotor blade aeroelastic stability.
- (b) Coupled rotor/fuselage dynamics for a single rotor.
- (c) Response cyclic, collective and higher harmonic control inputs.
- (d) Stability analysis of a tandem rotor system connected by a flexible structure.
- (e) Dynamics, aeroelasticity, and aeroelastic response of a Hybrid Heavy Lift Airship.

Depending on the type of system which one intends to analyze the complete equations presented in this document have to be simplified to fit the specific application.

In a sequel to this report entitled "Aeroelastic Effects in Multirotor Vehicles, Part II: Method of Solution and Results Illustrating Coupled Rotor/Body Aeromechanical Stability", two separate coupled rotor/body problems are

solved with considerable detail. In the first case the equations are used to predict the aeromechanical stability problem of a single rotor helicopter in ground resonance, including the effect of the aerodynamic forces. For this case high quality experimental results are available, and the agreement between theory and test was found to be quite good. In the second case, the stability of a simplified model vehicle (Fig. 2) representing an HHLA type vehicle in hover is analyzed, and the basic aeroelastic characteristics of such a vehicle are obtained.

The various details of the solution such as: evaluation of the equilibrium position, stability equations in multiblade coordinates and appropriate methods of solution are given in the second report, which constitutes a sequel to the present report.

REFERENCES

1. Friedmann, P., "Recent Developments in Rotary-Wing Aeroelasticity", Journal of Aircraft, Vol. 14, No. 11, pp. 1027-1042, Nov. 1977.
2. Johnson, W., Helicopter Theory, Princeton University Press, 1980.
3. Friedmann, P. and Yuan, C., "Effect of Modified Aerodynamic Strip Theories on Blade Aeroelastic Stability", AIAA Journal, Vol. 15, No. 7, pp. 932-940, July 1977.
4. Anderson, W.D. and Watts, G.W., "Rotor Blade Wake Flutter - A Comparison of Theory and Experiment", Journal of the American Helicopter Society, Vol. 21, pp. 32-43, April 1976.
5. Friedmann, P. and Kottapalli, S.B.R., "Rotor Blade Aeroelastic Stability and Response in Forward Flight", Proceedings of the Sixth European Rotorcraft and Powered Lift Aircraft Forum, Paper No. 14, Bristol, England, pp. 14.1-14.34, September 1980.
6. Bramwell, A.R.S., Helicopter Dynamics, John Wiley and Sons, 1976.
7. Goodyear Aerospace Corporation, "Study of Ground Handling Characteristics of a Maritime Patrol Airship", NASA CR 166253, March 1981.
8. Warmbrodt, W. and Friedmann, P., "Formulation of Coupled Rotor/Fuselage Equations of Motion", Vertica, Vol. 3, pp. 245-271, Dec. 1979.
9. Kunz, D.L., "A Nonlinear Response Analysis and Solution Method for Rotorcraft Vibration", Journal of the American Helicopter Society, Vol. 28, No. 1, January 1983, pp. 56-62.
10. Greenberg, J.M., "Airfoil in Sinusoidal Motion in a Pulsating Stream", NACA TN 1326, 1947.
11. Bisplinghoff, R.L., Ashley, H. and Halfman, R.L., "Aeroelasticity", Addison-Wesley Inc., 1955.
12. Hodges, D.H. and Ormiston, R.A., "Stability of Elastic Bending and Torsion of Uniform Cantilever Rotor Blades in Hover with Variable Structural Coupling", NASA TND-8192, 1976.
13. Ormiston, R.A. and Hodges, D.H., "Linear Flap-Lag Dynamics of Hingeless Helicopter Rotor Blades in Hover", Journal of the American Helicopter Society, Vol. 17, No. 2, pp. 2-15, April 1972.
14. Peters, D.A., "Flap-Lag Stability of Helicopter Rotor Blades in Forward Flight", Journal of the American Helicopter Society, pp. 2-13, Oct. 1975.

15. Houbolt, J.C. and Brooks, G.W., "Differential Equations of Motion for Combined Flapwise Bending, Chordwise Bending and Torsion of Twisted Nonuniform Rotor Blades", NACA Report 1346, 1958.
16. Rosen, A. and Friedmann, P., "Nonlinear Equations of Equilibrium for Elastic Helicopter or Wind Turbine Blades Undergoing Moderate Deformation", NASA CR-159478, December 1978.

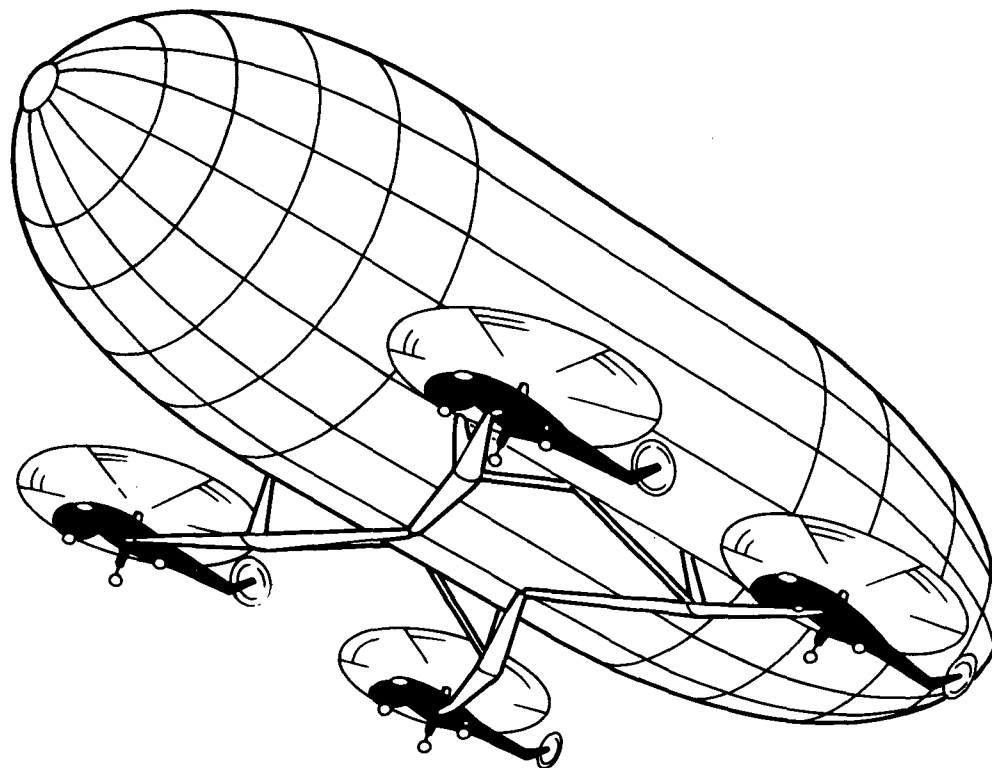

Figure 1. Hybrid Heavy Lift Airship - Approximate Configuration

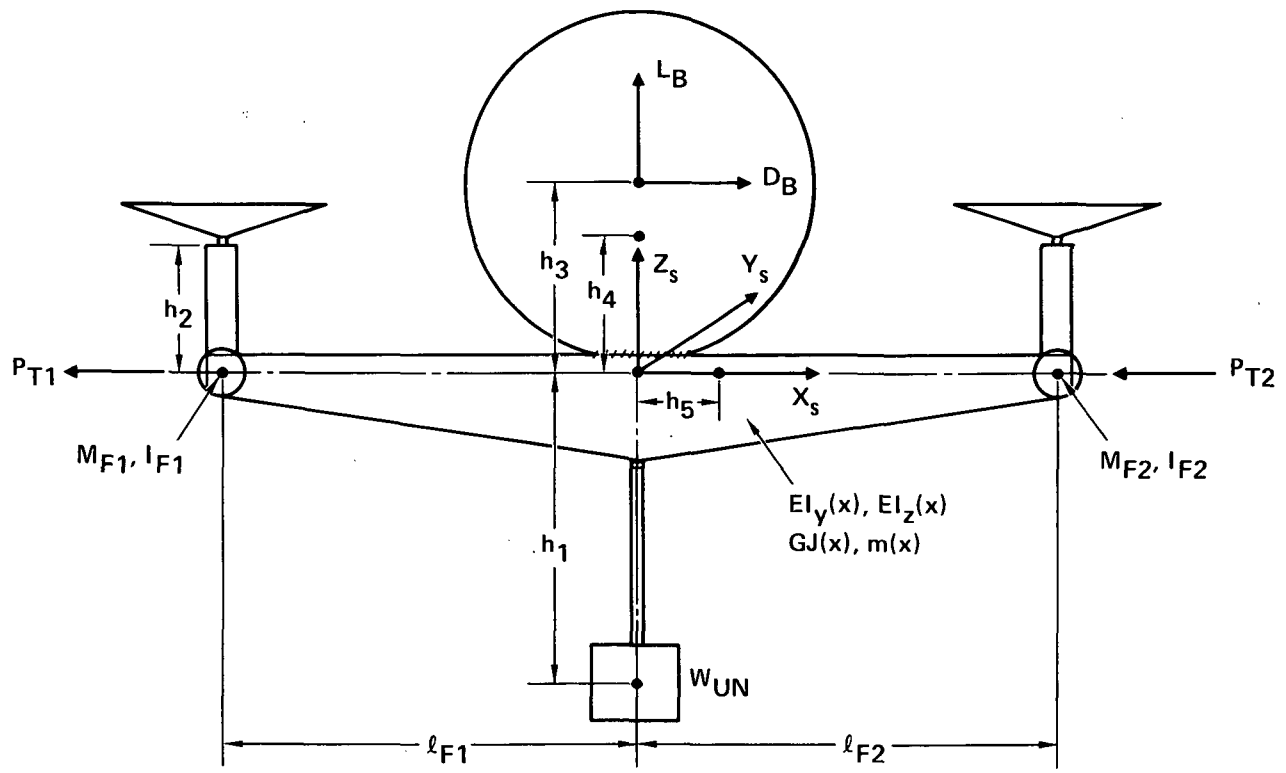

Figure 2. Sketch Showing the Main Ingredients of the Aeroelastic Model

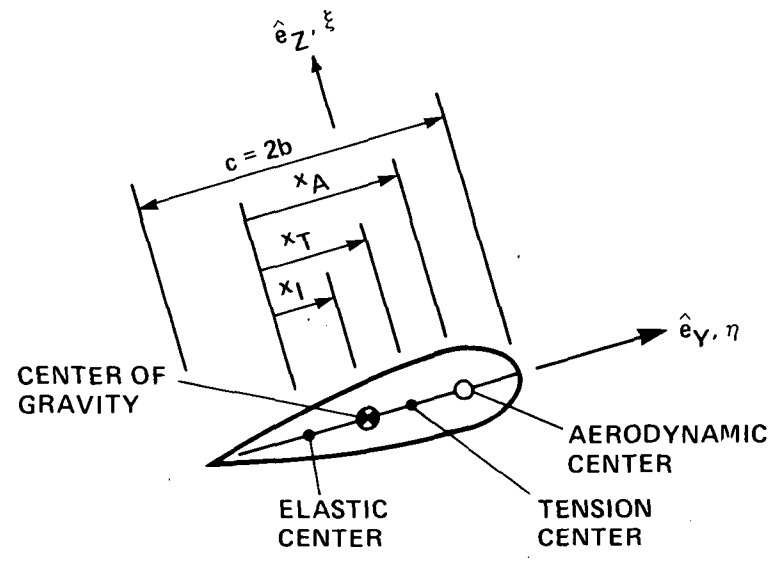

Figure 3. Blade Cross-Section Configuration

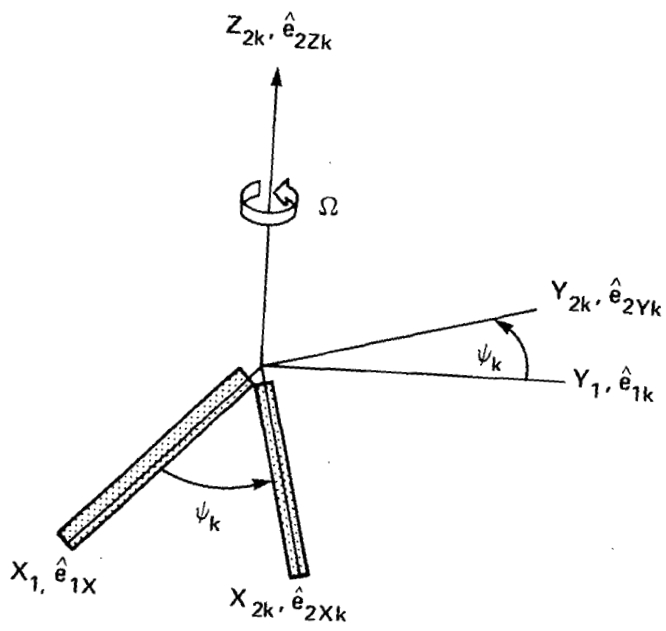

Figure 4. Disturbed Rotor Hub and Rotor Blade Coordinate Systems

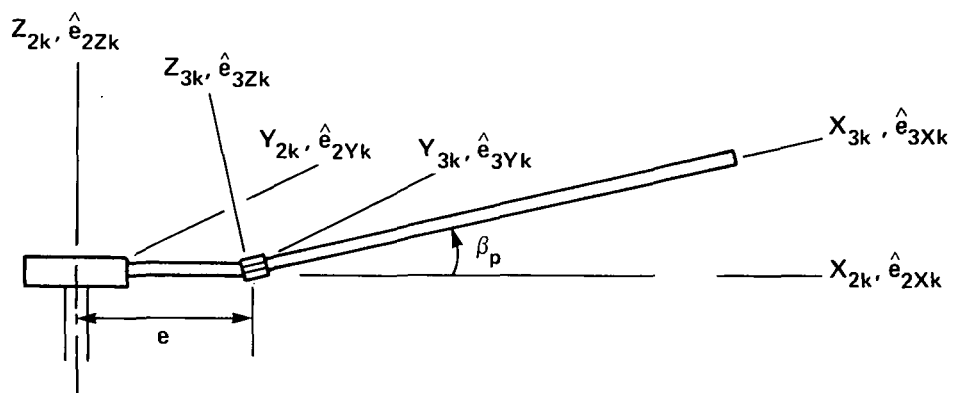

Figure 5. Rotor Blade Coordinate Systems

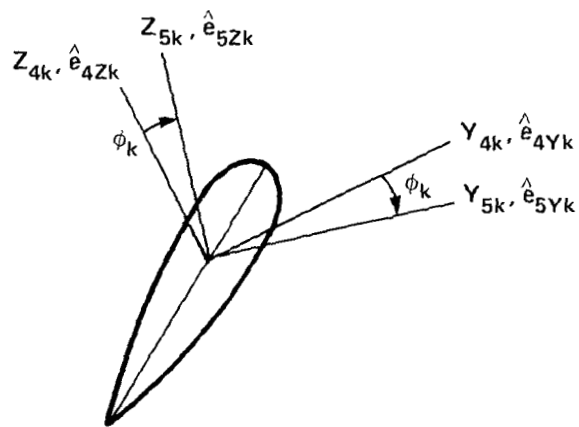

Figure 7. Deformed k^{th} Blade Cross-Section Coordinate Systems

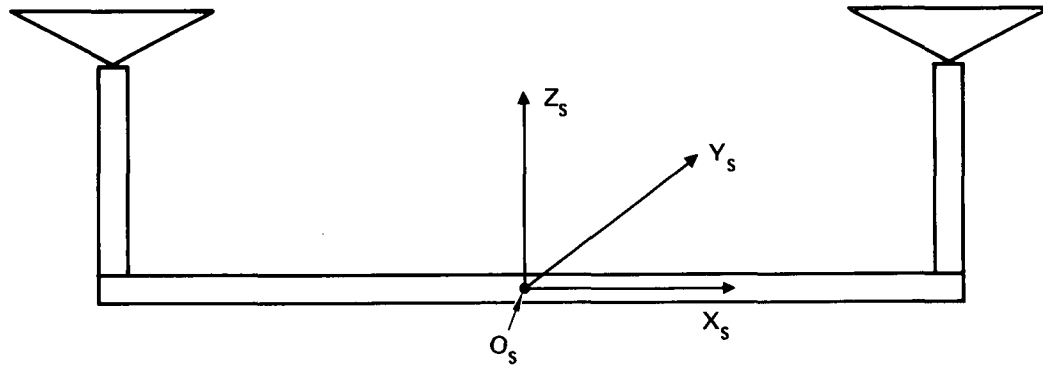

Figure 8. Inertial S-Coordinate System (Coincident with Body Fixed S1-System in Unperturbed State)

107

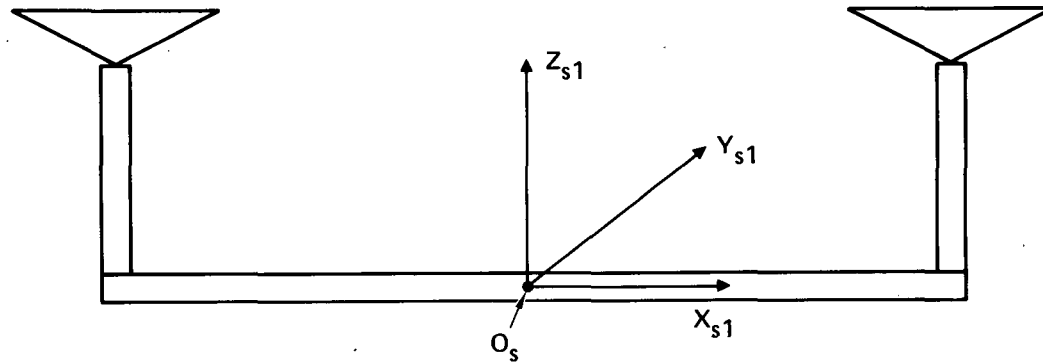

Figure 9. Body Fixed S1-Coordinate System (Obtained After Rigid Body Perturbational Motion) Elastic Deformations of the Supporting Structure Occur in this S1-System

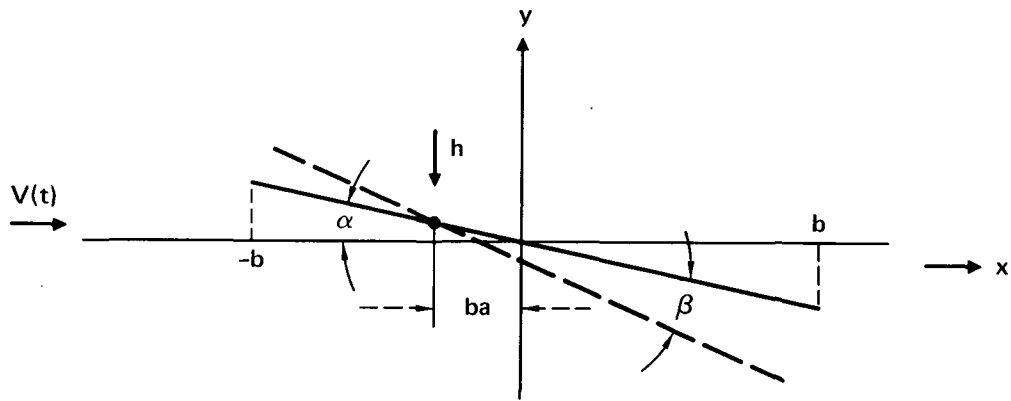
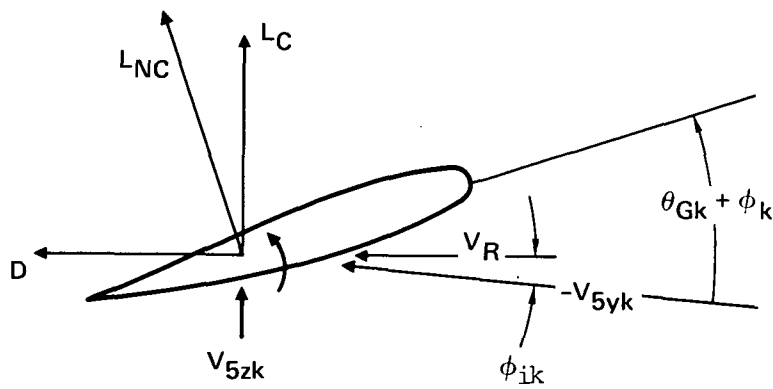

Figure 10. Geometry for Oscillating Airfoil in Pulsating Flow



V_R = RESULTANT VELOCITY

Figure 11. Relative Flow Velocities

L_C - Circulatory Lift Normal to the Resultant Flow

L_{NC} - Noncirculatory Lift Normal to the Blade Chord

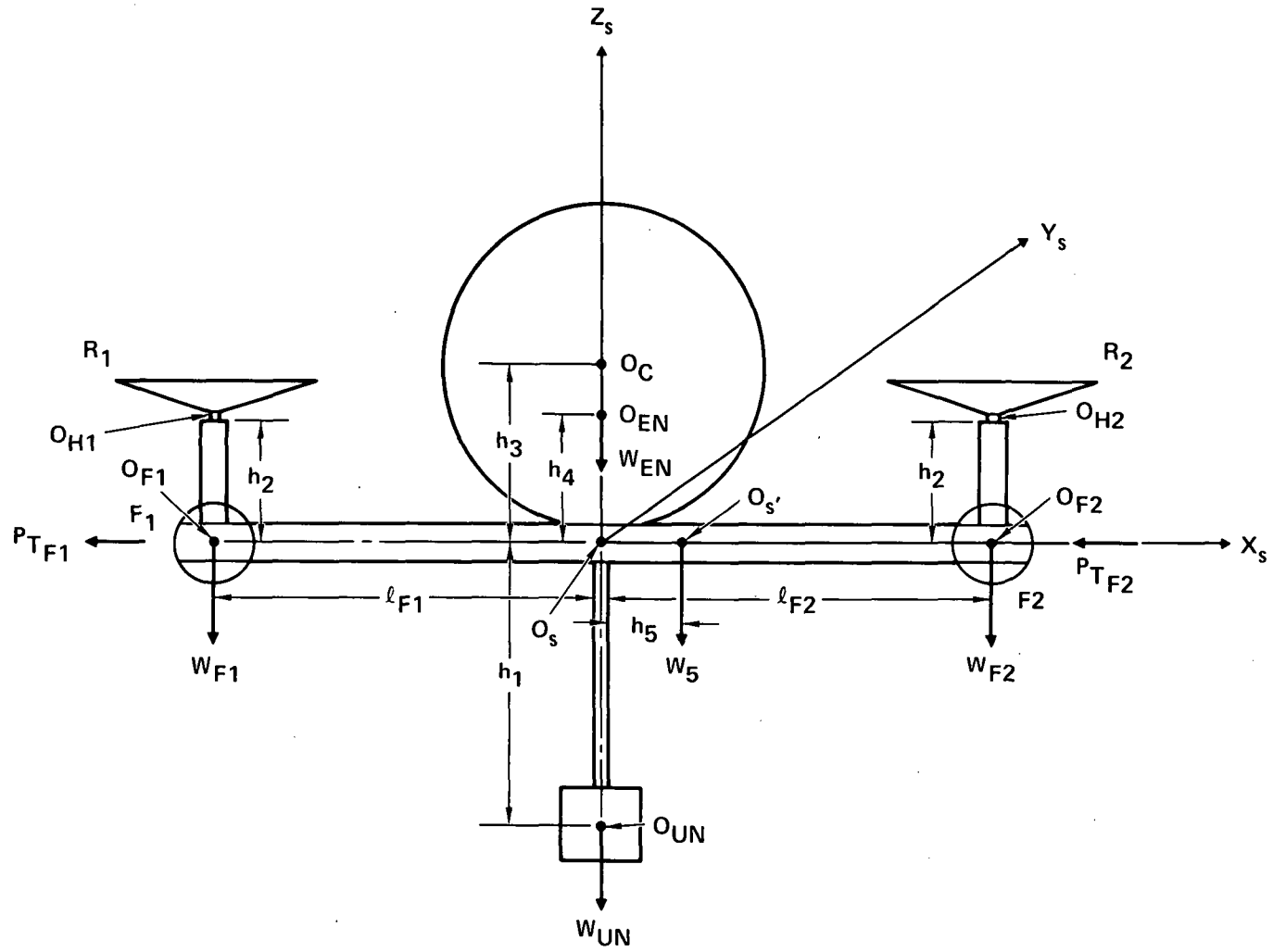

Figure 12. HHLA Model

Appendix A: Equivalent Structural Model for
Offset Hinged Spring Restrained Blades

A.1 General

In this Appendix the expressions for the elastic restoring moments acting at the hinge of a spring restrained blade are obtained. The root springs are representative of blade structural flexibility or they can represent flexures built into the blade, thus the model simulates the elastic properties of the configuration shown in Fig. A.1. The various expressions for the elastic restoring moments in flap, lead-lag and torsion, respectively, are derived. Subsequently these expressions are compared to similar equations obtained in previous studies. In this comparison both elastic hingeless blades as well as spring restrained equivalent models are considered. Furthermore it should be noted that the main advantage in using this simple model for an HHLA type vehicle consists of the capability of the model, to capture the essential behavior of both hingeless and articulated rotor configurations.

Ormiston and Hodges [Ref. 13] have derived one of the first models of this type, however Ref. 13 was restricted to the equivalent model of a hingeless spring restrained blade having only flap and lag degrees of freedom. The present model represents an extension of Ref. 13, to the case where both torsional blade flexibility as well as pitch link flexibility are incorporated in the blade model.

Peters [Ref. 14] has also derived a flap-lag model similar to Ormiston and Hodges. In both studies, Refs. 13 and 14, the flexibility of the hub has been also considered. A careful study of these two References reveals some discrepancies, which are associated primarily with the hub flexibility. The expressions for hub flexibility are also derived for our model since it was felt that these could be useful in some potential application. The final moment expressions obtained in this study are capable of representing the coupled flap-lag-torsional motion of both hingeless and articulated blades.

This Appendix is divided into three sections. In the first section the moment expressions, excluding hub flexibility, are derived for a spring restrained blade. The second section treats the special form of these equations for the case of an articulated blade. Finally the last section presents the moment equations for the blade including hub flexibility.

A.2 Moment Equations for a Hingeless Blade

The flexible elastic blade is modeled as a rigid blade with three orthogonal springs located at the root of the blade. These springs represent the flexibility of the blade in flap, lead-lag and torsion, respectively. In addition to these three springs, a torsional spring, in board of these three springs, is introduced to represent the control system or pitch link flexibility, see Fig. A1. It is assumed that the orientation of these springs does not change as the blade undergoes reorientation due to flap, lag and torsional motion. Consequently, the following question can be immediately raised. Since the torsion or twist of the blade is assumed to occur about the elastic axis of the blade which can have a different orientation as the blade flaps and lags, the spring representing the torsional stiffness of the blade should also change its orientation? The answer to this question is negative. Since the model is intended to represent a hingeless cantilevered blade for which the slope of the elastic axis at the root is always zero, irrespective of blade orientation. In our model, the torsional stiffness of the blade is represented by an equivalent torsional spring at the root. Hence, its orientation does not change with the blade motion. The spring stiffness are K_{β_B} for flapping, K_{ζ_B} for lead-lag, K_{ϕ_B} for torsion and K_{ϕ_C} for the pitch link flexibility. From the physics of the problem it is clear that these springs are all torsional type springs.

In deriving these equations the sign convention is important. All counter clock-wise rotations and moments are taken as positive. The restoring moment in any torsional spring, due to a positive displacement (i.e., rotation), is clock-wise and hence negative.

Another important ingredient in this derivation is the coordinate system. Let x, y, z be an orthogonal triad attached to the undeformed blade with zero pitch angle. The X -axis is along the elastic axis of the blade as shown in Fig. A2. The X', Y', Z' system represents another orthogonal triad, rotated through an angle θ about X -axis in the counter clock-wise direction. The angle θ represents the collective pitch of the blade shown in Fig. A2. The root springs representing the blade flexibility are oriented as follows: K_{β_B} along Y' axis, K_{ζ_B} along Z' axis and K_{ϕ_B}, K_{ϕ_C} along X' axis.

Using this information the expressions for the moments are derived next. To derive the expressions for the restoring moments of the springs, due to blade motion, the total angular displacement of the blade has to be decomposed into components along the directions of the spring restrained hinges. The rotational (angular) displacement components are then multiplied by the corresponding spring

stiffness to yield the appropriate moments about the hinges. Finally, the various moment vectors are expressed in terms of the component acting along the undeformed blade axes X, Y and Z respectively. These expressions are then compared with the results obtained in previous studies.

To arrive at the deformed blade orientation from the undeformed position a specific sequence of rotations are followed, namely flap, lag and torsion. The unit vectors in the directions of the undeformed and deformed blade coordinate systems are related by an Euler angle transformation which is derived below.

The flap rotation is assumed to take place first, thus the X,Y,Z axes system is rotated through an angle $(-\beta)$, in the clockwise direction, about Y-axis representing the flap hinge of the blade shown in Fig. A3. Components of the angular displacement $(-\beta)$ along X', Y', Z' axes can be obtained using the transformation

$$\begin{pmatrix} \hat{e}_{x'} \\ \hat{e}_{y'} \\ \hat{e}_{z'} \end{pmatrix} = \begin{bmatrix} 1 & 0 & 0 \\ 0 & \cos\theta & \sin\theta \\ 0 & -\sin\theta & \cos\theta \end{bmatrix} \begin{pmatrix} \hat{e}_x \\ \hat{e}_y \\ \hat{e}_z \end{pmatrix} \quad (\text{A.1})$$

where $\hat{e}_{x'}$, $\hat{e}_{y'}$, $\hat{e}_{z'}$ and \hat{e}_x , \hat{e}_y , \hat{e}_z are unit vectors along X', Y', Z' and X, Y, Z axes respectively.

Components of $(-\beta)$ along X', Y', Z' axes are along

$$\begin{aligned} X' &- 0 \\ Y' &- -\beta\cos\theta \\ Z' &- \beta\sin\theta \end{aligned} \quad (\text{A.2})$$

Due to this rotation $(-\beta)$, the coordinate system is rotated to a new position X_1, Y_1, Z_1 shown in Fig. A3. The transformation of unit vectors between the two systems is given by

$$\begin{pmatrix} \hat{e}_x \\ \hat{e}_y \\ \hat{e}_z \end{pmatrix} = \begin{bmatrix} \cos\beta & 0 & -\sin\beta \\ 0 & 1 & 0 \\ \sin\beta & 0 & \cos\beta \end{bmatrix} \begin{pmatrix} \hat{e}_{x1} \\ \hat{e}_{y1} \\ \hat{e}_{z1} \end{pmatrix} \quad (\text{A.3})$$

The lag rotation is assumed to take place next, the system X_1, Y_1, Z_1 is rotated about Z_1 axis through angle (ζ) , in the counter clock-wise direction, representing lead-lag motion of the blade, shown in Fig. A.4. Equation (A.3) is used to obtain the components of the angular displacement ' ζ ' along X,Y,Z axes.

These components are

$$\begin{aligned} \text{along } X &= -\zeta \sin\beta \\ Y &= 0 \\ Z &= \zeta \cos\beta \end{aligned} \quad (\text{A.4})$$

These components along X,Y,Z are transformed into components along the direction of the spring axes X',Y',Z' using equation (A.1). These components are:

$$\begin{aligned} \text{along } X' &= -\zeta \sin\beta \\ Y' &= \zeta \cos\beta \sin\theta \\ Z' &= \zeta \cos\beta \cos\theta \end{aligned} \quad (\text{A.5})$$

Next the X_1, Y_1, Z_1 axes system is rotated to a new position X_2, Y_2, Z_2 shown in Fig. A4. The relation between the unit vectors along X_2, Y_2, Z_2 and X_1, Y_1, Z_1 systems is given by

$$\begin{pmatrix} \hat{e}_{x1} \\ \hat{e}_{y1} \\ \hat{e}_{z1} \end{pmatrix} = \begin{bmatrix} \cos\zeta & -\sin\zeta & 0 \\ \sin\zeta & \cos\zeta & 0 \\ 0 & 0 & 1 \end{bmatrix} \begin{pmatrix} \hat{e}_{x2} \\ \hat{e}_{y2} \\ \hat{e}_{z2} \end{pmatrix} \quad (\text{A.6})$$

Combining equations (A.6) and (A.3), the transformation of unit vectors between X_2, Y_2, Z_2 and X, Y, Z systems; given below is obtained.

$$\begin{pmatrix} \hat{e}_x \\ \hat{e}_y \\ \hat{e}_z \end{pmatrix} = \begin{bmatrix} \cos\beta \cos\zeta & -\cos\beta \sin\zeta & -\sin\beta \\ \sin\zeta & \cos\zeta & 0 \\ \sin\beta \cos\zeta & -\sin\beta \sin\zeta & \cos\beta \end{bmatrix} \begin{pmatrix} \hat{e}_{x2} \\ \hat{e}_{y2} \\ \hat{e}_{z2} \end{pmatrix} \quad (\text{A.7})$$

Finally the torsional rotation is assumed to take place. To represent torsion, the blade is rotated through an angle (ϕ) in the counter clock-wise direction along the X_2 axis, as shown in Fig. A5. The components of the angular displacement (ϕ) along X, Y, Z system are obtained using equation (A.7). These components are respectively:

$$\begin{aligned} \text{along } X &= \phi \cos\beta \cos\zeta \\ Y &= \phi \sin\zeta \\ Z &= \phi \sin\beta \cos\zeta \end{aligned} \quad (\text{A.8})$$

These components are again transformed in the X', Y', Z' directions using equation (A.1). The corresponding components are

$$\begin{aligned}
 \text{along } X' &= \phi \cos \beta \cos \zeta \\
 Y' &= \phi \sin \zeta \cos \theta + \phi \sin \theta \sin \beta \cos \zeta \\
 Z' &= -\phi \sin \zeta \sin \theta + \phi \cos \theta \sin \beta \cos \zeta
 \end{aligned} \tag{A.9}$$

The total twist of the various springs oriented along X', Y', Z' axes is obtained by adding equations (A.2), (A.5) and (A.9). The various components can be identified as:

$$\begin{aligned}
 \text{along } X' &= -\zeta \sin \beta + \phi \cos \beta \cos \zeta \\
 Y' &= -\beta \cos \theta + \zeta \cos \beta \sin \theta + \phi \sin \zeta \cos \theta \\
 &\quad + \phi \sin \beta \cos \zeta \sin \theta \\
 Z' &= \beta \sin \theta + \zeta \cos \beta \cos \theta - \phi \sin \zeta \sin \theta \\
 &\quad + \phi \sin \beta \cos \zeta \cos \theta
 \end{aligned} \tag{A.10}$$

In the model shown in Fig. A1, the springs representing the torsional stiffness of the blade and the pitch link stiffness are in series and are along X' axis. These two springs can be combined and can be represented by an equivalent spring of stiffness $K_\phi = K_{\phi_B} \cdot K_{\phi_C} / (K_{\phi_B} + K_{\phi_C})$, when K_{ϕ_C} is very large, then K_ϕ becomes K_{ϕ_B} . The restoring moments in the springs, due to the flap, lag and torsional rotation of the blade can be written as

$$\begin{aligned}
 M_{X'} &= -K_\phi (-\zeta \sin \beta + \phi \cos \beta \cos \zeta) \\
 M_{Y'} &= -K_{\beta_B} (-\beta \cos \theta + \zeta \cos \beta \sin \theta + \phi \sin \zeta \cos \theta + \phi \sin \beta \cos \zeta \sin \theta) \\
 M_{Z'} &= -K_{\zeta_B} (\beta \sin \theta + \zeta \cos \beta \cos \theta - \phi \sin \zeta \sin \theta + \phi \sin \beta \cos \zeta \cos \theta)
 \end{aligned} \tag{A.11}$$

Transformation of these moments along the undeformed blade axes (X,Y,Z), yields the torsional, flapping and lead-lag restoring moments, associated with blade motion. These are:

Torsional moment

$$M_x = -K_\phi (-\zeta \sin\beta + \phi \cos\beta \cos\zeta)$$

Flapping moment

$$M_y = -K_{\beta_B} \cos\theta (-\beta \cos\theta + \zeta \cos\beta \sin\theta + \phi \sin\zeta \cos\theta + \phi \sin\beta \cos\zeta \sin\theta) \\ + K_{\zeta_B} \sin\theta (\beta \sin\theta + \zeta \cos\beta \cos\theta - \phi \sin\zeta \sin\theta + \phi \sin\beta \cos\zeta \cos\theta)$$

Lead-lag moment

$$M_z = -K_{\beta_B} \sin\theta (-\beta \cos\theta + \zeta \cos\beta \sin\theta + \phi \sin\zeta \cos\theta + \phi \sin\beta \cos\zeta \sin\theta) \\ - K_{\zeta_B} \cos\theta (\beta \sin\theta + \zeta \cos\beta \cos\theta - \phi \sin\zeta \sin\theta + \phi \sin\beta \cos\zeta \cos\theta) \quad (A.12)$$

Assuming β and ζ are small angles and making the approximation $\sin\beta \approx \beta$, $\sin\zeta \approx \zeta$, $\cos\beta \approx 1$ and $\cos\zeta \approx 1$, equation (A.12) can be simplified to yield

$$M_x = -K_\phi (-\zeta\beta + \phi) \\ M_y = -K_{\beta_B} \cos\theta (-\beta \cos\theta + \zeta \sin\theta + \phi \zeta \cos\theta + \phi \beta \sin\theta) \\ + K_{\zeta_B} \sin\theta (\beta \sin\theta + \zeta \cos\theta - \phi \zeta \sin\theta + \phi \beta \cos\theta) \quad (A.13) \\ M_z = -K_{\beta_B} \sin\theta (-\beta \cos\theta + \zeta \sin\theta + \phi \zeta \cos\theta + \phi \beta \sin\theta) \\ - K_{\zeta_B} \cos\theta (\beta \sin\theta + \zeta \cos\theta - \phi \zeta \sin\theta + \phi \beta \cos\theta)$$

Rearranging the terms,

$$M_x = -K_\phi (-\zeta\beta + \phi) \\ M_y = (\beta - \phi\zeta)(K_{\beta_B} \cos^2\theta + K_{\zeta_B} \sin^2\theta) + (\zeta + \phi\beta)(K_{\zeta_B} - K_{\beta_B}) \sin\theta \cos\theta \\ M_z = -(\zeta + \phi\beta)(K_{\beta_B} \sin^2\theta + K_{\zeta_B} \cos^2\theta) - (\beta - \phi\zeta)(K_{\zeta_B} - K_{\beta_B}) \sin\theta \cos\theta \quad (A.14)$$

Equation (A.14) represents the torsional, flap and lag restoring moments of the springs due to the flap, lag and torsional motion of the blade.

These expressions for the restoring moments acting on the spring restrained model of the blade are compared with results published in previous studies. For completeness these comparisons are carried out for both spring restrained models of a hingeless blade and fully elastic representations of the hingeless blade.

Ormiston and Hodges [Ref. 13] presented moment expressions for a spring restrained model of a rotor blade representing a hingeless blade. They have also taken hub flexibility into account. In order to compare the results obtained in Ref. 13 with the expression obtained in this report, the hub stiffness is allowed to become infinite, thus only the simplified expressions are compared. Recall that the torsional degree of freedom was not considered in Ref. 13. The expressions [Ref. 13] for the restoring moments are:

Flapping moment (Eq. 44 of Ref. 13)

$$M_y = -\beta(K_{\beta_B} \cos^2\theta + K_{\zeta_B} \sin^2\theta) - \zeta(K_{\zeta_B} - K_{\beta_B}) \sin\theta\cos\theta \quad (a)$$

Lead-lag moment (Eq. 45 of Ref. 13)

$$M_z = -\zeta(K_{\beta_B} \sin^2\theta + K_{\zeta_B} \cos^2\theta) - \beta(K_{\zeta_B} - K_{\beta_B}) \sin\theta\cos\theta \quad (b)$$

Setting $\phi = 0$ in Eqs. (A.14) yields

$$\begin{aligned} M_x &= K_{\phi_B} \zeta\beta \\ M_y &= \beta(K_{\beta_B} \cos^2\theta + K_{\zeta_B} \sin^2\theta) + \zeta(K_{\zeta_B} - K_{\beta_B}) \sin\theta\cos\theta \\ M_z &= -\zeta(K_{\beta_B} \sin^2\theta + K_{\zeta_B} \cos^2\theta) - \beta(K_{\zeta_B} - K_{\beta_B}) \sin\theta\cos\theta \end{aligned} \quad (A.15)$$

By comparing equations (a) and (b) with equation (A.15), we find there is a negative sign in the expression for M_y . The reason for this discrepancy is that the authors of Ref. 13 used different sign convention. In their case, M_y clockwise is positive and M_z counter clock-wise is also positive. The authors of Ref. 13 have used this sign convention because their objective was to derive a blade model which was a simple analog to the flexible blade equations (hingeless) which were derived by Houbolt and Brooks [Ref. 15] who have employed the same sign convention for M_y and M_z . The expression of the present study are also compared with the results of an elastic blade model. The moment expressions obtained by Rosen and Friedmann [Ref. 16] for an elastic blade are (Eqs. (15) of Ref. 16)

$$\begin{aligned} M_x &= GJ(\phi_{,x} + v_{,xx} w_{,x}) \\ M_y &= -(EI_2 - EI_3) \sin\theta\cos\theta(v_{,xx} + \phi w_{,xx}) \\ &\quad -(EI_2 \sin^2\theta + EI_3 \cos^2\theta)(w_{,xx} - \phi v_{,xx}) \end{aligned}$$

$$M_z = (EI_2 - EI_3) \sin\theta \cos\theta (w_{,xx} - \phi v_{,xx}) + (EI_2 \cos^2\theta + EI_3 \sin^2\theta) (v_{,xx} + \phi w_{,xx}) \quad (c)$$

where v , w , ϕ represent the elastic lead-lag displacement, flap displacement and twist at any section of the blade, and the quantities EI_2 , EI_3 , GJ represent lead-lag, flap and torsional stiffness of the blade.

The expressions obtained in Ref. 16 represent the applied moments, thus to obtain the restoring moments Equation (c) have to be multiplied by (-1) and the resulting expressions are compared with Eqs. (A.14). The expressions for M_y and M_z are the same, however there is a sign difference in the expression for torsional moment. The expression derived in this study contains a term $(\phi - \zeta\beta)$ while the corresponding term in Ref. 16 is $(\phi_{,x} + v_{,xx} w_{,x})$. This discrepancy is due to a different sequence of rotation followed by Rosen and Friedmann [Ref. 16]. The sequence of rotations adopted in Ref. 16 was lead-lag, flap and torsion. When a sequence of flap, lead-lag and torsion, such as employed in the present study is used, the results of Ref. 16 are in agreement with the results obtained in this study. Equations (c), representing a hingeless blade, with Eqs. (A.14) corresponding to the rigid, offset hinged spring restrained blade model one can identify a number equivalence relations, which provide some physical insight. These equivalence relations are given below. For torsion one has

$$GJ(\phi_{,x} - v_{,xx} w_{,x}) = K_\phi (\phi - \zeta\beta) \quad (A.16)$$

where

$$K_\phi = K_{\phi_B} K_{\phi_C} / (K_{\phi_B} + K_{\phi_C})$$

If the pitch link flexibility is very large, i.e. $K_{\phi_C} \rightarrow \infty$ then K_ϕ becomes K_{ϕ_B} . We shall consider only K_{ϕ_B} in Eq. (A.16) because Rosen and Friedmann have not considered the pitch link flexibility. Thus equation (A.16) should be rewritten as

$$GJ(\phi_{,x} - v_{,xx} w_{,x}) = K_{\phi_B} (\phi - \zeta\beta) \quad (A.17)$$

Comparison of the various other terms yields

$$(EI_2 - EI_3)(v_{,xx} + \phi w_{,xx}) = (K_{\zeta_B} - K_{\beta_B})(\zeta + \beta\phi) \quad (A.18)$$

$$EI_2 (w_{,xx} - \phi v_{,xx}) = K_{\zeta_B} (\beta - \phi\zeta) \quad (A.19)$$

$$EI_3 (w_{,xx} - \phi v_{,xx}) = K_{\beta_B} (\beta - \phi \zeta) \quad (A.20)$$

$$(EI_2 - EI_3) (w_{,xx} - \phi v_{,xx}) = (K_{\zeta_B} - K_{\beta_B}) (\beta - \phi \zeta) \quad (A.21)$$

$$EI_2 (v_{,xx} + \phi w_{,xx}) = K_{\zeta_B} (\zeta + \phi \beta) \quad (A.22)$$

$$EI_3 (v_{,xx} + \phi w_{,xx}) = K_{\beta_B} (\zeta + \phi \beta) \quad (A.23)$$

Setting $\phi = 0$ in equations (A.19), (A.20), (A.22) and (A.23) yields

$$EI_2 w_{,xx} = K_{\zeta_B} \beta$$

$$EI_3 w_{,xx} = K_{\beta_B} \beta$$

$$EI_2 v_{,xx} = K_{\zeta_B} \zeta$$

$$EI_3 v_{,xx} = K_{\beta_B} \zeta \quad (A.24)$$

Examination of these expressions reveals that K_{ζ_B} , K_{β_B} represent the lead-lag and flap stiffness EI_2 , EI_3 respectively and β, ζ correspond to the curvatures in the elastic blade analysis. Comparison of the appropriate terms in equation (A.17) reveals

$$GJ = K_{\phi_B}$$

$$\phi_{,x} = \phi$$

$$w_{,x} = \beta \quad (A.25)$$

This comparison indicates that both $w_{,xx}$ and $w_{,x}$ can be identified as quantities corresponding to the flapping angle β in the rigid spring restrained blade model. This statement requires further clarification. The comparison outlined above indicates that when dealing with moment terms, such as $EI w_{,xx}$, β has the role of the curvature. However when

examining the role of β in the various transformations relating the unit vectors of the deformed and undeformed states of the blade the role of β corresponds to $w_{,x}$ in the flexible blade equations. Furthermore it can be seen that $\phi_{,x}$ in an elastic blade corresponds ϕ in a rigid blade model, this is due to the fact that the torsional moment in an elastic blade is defined as $GJ\phi_{,x}$ whereas in the spring restrained blade model the torsional elastic restoring moment is $K_{\phi}\phi$.

A.3 Moment Equations for an Articulated Blade

A typical articulated blade, which has no root springs in flap and lag will not experience elastic restoring moments in about these hinges. Therefore the model proposed for this case, shown in Fig. A6, involves only a torsional spring and no springs for flap and lag. In the model shown in Fig. A6, two torsional springs are provided. The spring K_{ϕ_B} represents the blade torsional stiffness and K_{ϕ_C} represents the control link stiffness. These are aligned along the undeformed blade axis x . Since the blade can perform flap and lag motions during operation, the spring K_{ϕ_B} can orient itself along any direction in space provided the pitch link is inboard of flap and lag hinges. The spring K_{ϕ_C} remains along the undeformed x -axis. If the pitch link is outboard of leading and flap hinges, then both K_{ϕ_B} and K_{ϕ_C} change their orientation as the blade undergoes flap and lag motion. Therefore one needs to consider two cases: (a) pitch link inboard of flap and lag hinges and (b) pitch link outboard of flap and lag hinges.

Case (a) Pitch Link Inboard of Flap and Lag Hinges

Consider Fig. A.6 numbers 1, 2, 3 refer to three nodes. At node 2, the two springs K_{ϕ_B} and K_{ϕ_C} are connected. The springs are oriented along the undeformed elastic axis (X -axis of the coordinate system). In this case, since the pitch link is inboard of flap and lag hinges, only K_{ϕ_B} takes on different orientation as the blade undergoes flap and lead-lag deformation.

Assume that the blade has undergone a flap deflection ($-\beta$) and a lag deflection (ζ) respectively, as shown in Fig. A7. The new position of the elastic axis is X_2 and the deformed coordinate system is X_2, Y_2, Z_2 . The spring associated with blade torsional stiffness, K_{ϕ_B} , is now oriented along the X_2 axis and the spring associated with pitch link stiffness, K_{ϕ_C} is oriented along the undeformed axis, i.e. X -axis. For this case one may write a stiffness matrix relating moments to angular rotations as indicated in Eq. (A.26).

$$\begin{array}{l}
\left\{ \begin{array}{l} M_x^1 \\ M_y^1 \\ M_z^1 \\ M_x^2 \\ M_y^2 \\ M_z^2 \\ M_x^3 \\ M_y^3 \\ M_z^3 \end{array} \right\} = \begin{array}{c} \left[\begin{array}{cccccccc}
K_{\phi_B} \cos^2 \beta \cos^2 \zeta & & & & & & & & \\
K_{\phi_B} \cos \beta \cos \zeta \sin \zeta & K_{\phi_B} \sin^2 \zeta & & & & & & & \\
K_{\phi_B} \cos \beta \cos^2 \zeta \sin \beta & K_{\phi_B} \sin \beta \cos \zeta \sin \zeta & K_{\phi_B} \sin^2 \beta \cos^2 \zeta & & & & & & \\
-K_{\phi_B} \cos^2 \beta \cos^2 \zeta & -K_{\phi_B} \cos \beta \cos \zeta \sin \zeta & -K_{\phi_B} \cos \beta \cos^2 \zeta \sin \beta & K_{\phi_C} + K_{\phi_B} \cos^2 \beta \cos^2 \zeta & & & & & \\
-K_{\phi_B} \cos \beta \cos \zeta \sin \zeta & -K_{\phi_B} \sin^2 \zeta & -K_{\phi_B} \sin \beta \cos \zeta \sin \zeta & K_{\phi_B} \cos \beta \cos \zeta \sin \zeta & K_{\phi_B} \sin^2 \zeta & & & & \\
-K_{\phi_B} \cos \beta \cos^2 \zeta \sin \beta & -K_{\phi_B} \sin \beta \cos \zeta \sin \zeta & -K_{\phi_B} \sin^2 \beta \cos^2 \zeta & K_{\phi_B} \cos \beta \cos^2 \zeta \sin \beta & K_{\phi_B} \sin \beta \cos \zeta \sin \zeta & K_{\phi_B} \sin^2 \beta \cos^2 \zeta & & & \\
0 & 0 & 0 & -K_{\phi_C} & 0 & 0 & K_{\phi_C} & & \\
0 & 0 & 0 & 0 & 0 & 0 & 0 & 0 & \\
0 & 0 & 0 & 0 & 0 & 0 & 0 & 0 & 0
\end{array} \right] \begin{array}{l} \\ \\ \\ \\ \\ \\ \\ \\ \\ \\
\end{array}
\end{array}
\right. \left. \begin{array}{l} \\ \\ \\ \\ \\ \\ \\ \\ \\ \\
\end{array} \right\}$$

Symmetric

(A.26)

This stiffness matrix relates the generalized displacements (rotations along X, Y, Z directions) and the moments at nodes 1,2,3. In equation (A.26), $M_{x,y,z}^i$ represents the moments along X,Y,Z axes at node i and $\phi_{x,y,z}^i$ represents the rotations along X,Y,Z axes at node i.

The equivalent stiffnesses of the system in torsion are obtained from the solution of this matrix equation. The conditions under which this equation is solved are

$$\phi_x^3 = \phi_y^3 = \phi_z^3 = 0 \quad \text{Node 3 is fixed}$$

and

$$M_x^2 = M_y^2 = M_z^2 = 0 \quad \text{No external moment at node 2}$$

When trying to solve the matrix equation under these conditions the individual equations for M_x^i , M_y^i , M_z^i become redundant. This redundancy is due to the rigid body degrees of freedom being included in the model. The physical reason for this redundancy is due to the fact that the moment along the Y and Z axes cannot be resisted by this spring model. In order to overcome this difficulty, it is assumed that the flap and lead-lag angles are very small while the spring K_{ϕ_B} is oriented along the undeformed elastic axis, i.e., X-axis. The springs K_{ϕ_B} and K_{ϕ_C} are in series and are oriented along X-axis and can be combined. For this model, the relation between the torsional moment and the twist ϕ of the blade becomes

$$\begin{aligned} M_x &= [K_{\phi_B} K_{\phi_C} / (K_{\phi_B} + K_{\phi_C})] \phi \\ &= K_{\phi} \phi \end{aligned} \quad (\text{A.27})$$

Case (b) Pitch Link Outboard of Flap-Lag Hinges

When the pitch link is outboard of the flap-lag hinges both the springs K_{ϕ_B} and K_{ϕ_C} are always oriented in the same direction, from which the following relation between torsional moment and elastic twist is obtained.

$$M_x = [K_{\phi_B} K_{\phi_C} / (K_{\phi_B} + K_{\phi_C})] \phi \quad (\text{A.28})$$

Therefore for an articulated blade, notwithstanding whether the flap and lag hinges are inboard or outboard of the pitch link, the relation between the torsional moment and the elastic twist is given by

$$\begin{aligned} M_x &= [K_{\phi_B} K_{\phi_C} / (K_{\phi_B} + K_{\phi_C})] \phi \\ &= K_{\phi} \phi \end{aligned} \quad (\text{A.29})$$

Combining this result with the result for a hingeless blade, discussed previously, the general elastic restoring moment expressions become;

$$\text{Torsion: } M_x = -K_{\phi_1} (\phi - \zeta\beta) - K_{\phi_2} \phi$$

$$\text{Flap: } M_y = (\beta - \phi\zeta)(K_{\beta_B} \cos^2\theta + K_{\zeta_B} \sin^2\theta) + (\phi\beta + \zeta)(K_{\zeta_B} - K_{\beta_B}) \sin\theta \cos\theta$$

$$\text{Lead-lag: } M_z = -(\zeta + \phi\beta)(K_{\beta_B} \sin^2\theta + K_{\zeta_B} \cos^2\theta) - (\beta - \phi\zeta)(K_{\zeta_B} - K_{\beta_B}) \sin\theta \cos\theta \quad (\text{A.30})$$

For a hingeless blade

$$K_{\phi_2} = 0 \text{ and } K_{\phi_1} = \frac{K_{\phi_C} K_{\phi_B}}{K_{\phi_B} + K_{\phi_C}}$$

for an articulated blade

$$K_{\phi_1} = 0, \quad K_{\beta_B} = 0, \quad K_{\zeta_B} = 0$$

and

$$K_{\phi_2} = \frac{K_{\phi_C} K_{\phi_B}}{K_{\phi_B} + K_{\phi_C}}$$

A.4 Elastic Restoring Moments on a Rigid Blade with Root Springs and Hub Flexibility

In this section, the elastic restoring moments due to the root springs and due to the hub flexibility are derived. The model for this system based on equivalent springs is illustrated in Fig. A8. There are two sets of orthogonal springs, springs with stiffness K_{β_B} , K_{ζ_B} and K_{ϕ_B} which represent the blade stiffness in flap, lead-lag and torsion, respectively. The spring constant K_{ϕ_C} represents the stiffness of the pitch link system and K_{ζ_H} and K_{β_H} are the stiffnesses of the hub in flap and lead-lag directions. The hub is assumed to be torsionally rigid. The X,Y,Z axis system represents the undeformed blade coordinates with the X-axis oriented along the elastic axis. The system X', Y', Z' corresponds to the X, Y, Z axis system after a counter clock-wise rotation about the X-axis by an angle θ . The angle θ represents the collective pitch of the blade.

The orientation of the various springs is as follows: K_{ζ_H} is along Z-axis, K_{β_H} is along Y-axis, K_{β_B} is along Y'-axis, K_{ζ_B} is along Z'-axis, K_{ϕ_B} and K_{ϕ_C} are along X-axis (see Fig. A8). The numbers 1, 2, 3 in Fig. A8 refer to the three nodes. The blade spring system is attached to the hub spring system at node 2.

The relation between the moments and the angular displacements for this equivalent spring system describing the combined blade and hub is given by the matrix equation (A.31), on the next page.

In equation (A.31) M_x^i , M_y^i , M_z^i refer to the elastic moments at node i in the X,Y,Z directions, respectively and ϕ_x^i , ϕ_y^i , ϕ_z^i refer to the angular displacements at node i in the X,Y,Z directions, respectively. The various moments are obtained in terms of the angular displacements by solving this matrix equation subject to the following conditions:

When the hub is fixed, the angular displacements at node 3 are zero and then

$$\phi_x^3 = \phi_y^3 = \phi_z^3 = 0 \quad (A.32)$$

Since there is no external moment at node 2,

$$M_x^2 = M_y^2 = M_z^2 = 0 \quad (A.33)$$

Solving the matrix equation, Eq. (A.31) subject to the conditions given in equations (A.32) and (A.33) and recognizing that $M_x^2 = M_y^2 = M_z^2 = 0$ one obtains

$$\begin{aligned} & -(K_{\zeta_B} \cos^2 \theta + K_{\beta_B} \sin^2 \theta) \phi_z^1 - (K_{\beta_B} - K_{\zeta_B}) \sin \theta \cos \theta \phi_y^1 = \\ & -(K_{\zeta_H} + K_{\zeta_B} \cos^2 \theta + K_{\beta_B} \sin^2 \theta) \phi_z^2 - (K_{\beta_B} - K_{\zeta_B}) \sin \theta \cos \theta \phi_y^2 \end{aligned} \quad (A.34)$$

$$\begin{Bmatrix} M_z^1 \\ M_y^1 \\ M_x^1 \\ M_z^2 \\ M_y^2 \\ M_x^2 \\ M_z^3 \\ M_y^3 \\ M_x^3 \end{Bmatrix} = \begin{bmatrix} K_{\zeta_B} \cos^2 \theta + K_{\beta_B} \sin^2 \theta & (K_{\beta_B} - K_{\zeta_B}) \sin \theta \cos \theta & 0 & -(K_{\zeta_B} \cos^2 \theta + K_{\beta_B} \sin^2 \theta) & -(K_{\beta_B} - K_{\zeta_B}) \sin \theta \cos \theta & 0 & 0 & 0 & 0 \\ & K_{\zeta_B} \sin^2 \theta + K_{\beta_B} \cos^2 \theta & 0 & -(K_{\beta_B} - K_{\zeta_B}) \sin \theta \cos \theta & -(K_{\zeta_B} \sin^2 \theta + K_{\beta_B} \cos^2 \theta) & 0 & 0 & 0 & 0 \\ & & K_{\phi_B} & 0 & 0 & -K_{\phi_B} & 0 & 0 & 0 \\ & & & K_{\zeta_H} + K_{\zeta_B} \cos^2 \theta + K_{\beta_B} \sin^2 \theta & (K_{\beta_B} - K_{\zeta_B}) \sin \theta \cos \theta & 0 & -K_{\zeta_H} & 0 & 0 \\ & & & & & K_{\beta_H} + K_{\beta_B} \cos^2 \theta + K_{\zeta_B} \sin^2 \theta & 0 & 0 & -K_{\beta_H} \\ & & & & & & K_{\phi_B} + K_{\phi_C} & 0 & -K_{\phi_C} \\ & & & & & & & K_{\zeta_H} & 0 \\ & & & & & & & & K_{\beta_H} & 0 \\ & & & & & & & & & K_{\phi_C} \end{bmatrix} \begin{Bmatrix} \phi_z^1 \\ \phi_y^1 \\ \phi_x^1 \\ \phi_z^2 \\ \phi_y^2 \\ \phi_x^2 \\ \phi_z^3 \\ \phi_y^3 \\ \phi_x^3 \end{Bmatrix}$$

Symmetric

(A.31)

$$\begin{aligned}
& -(K_{\beta_B} - K_{\zeta_B}) \sin\theta \cos\theta \phi_z^1 - (K_{\beta_B} \cos^2\theta + K_{\zeta_B} \sin^2\theta) \phi_y^1 = \\
& - \phi_z^2 (K_{\beta_B} - K_{\zeta_B}) \sin\theta \cos\theta - (K_{\beta_H} + K_{\beta_B} \cos^2\theta + K_{\zeta_B} \sin^2\theta) \phi_y^2
\end{aligned} \tag{A.35}$$

$$- K_{\phi_B} \phi_x^1 = -(K_{\phi_B} + K_{\phi_C}) \phi_x^2 \tag{A.36}$$

From Eqs. (A.34), (A.35) and (A.36) ϕ_x^2 , ϕ_y^2 and ϕ_z^2 can be expressed in terms of ϕ_x^1 , ϕ_y^1 , ϕ_z^1 , thus

$$\phi_x^2 = K_{\phi_B} / (K_{\phi_B} + K_{\phi_C}) \phi_x^1 \tag{A.37}$$

$$\begin{bmatrix} \phi_z^2 \\ \phi_y^2 \end{bmatrix} = \begin{bmatrix} K_{\beta_H} + K_{\beta_B} \cos^2\theta & -(K_{\beta_B} - K_{\zeta_B}) \\ +K_{\zeta_B} \sin^2\theta & \sin\theta \cos\theta \\ -(K_{\beta_B} - K_{\zeta_B}) & K_{\zeta_H} + K_{\zeta_B} \cos^2\theta \\ \sin\theta \cos\theta & +K_{\beta_B} \sin^2\theta \end{bmatrix} \begin{bmatrix} (K_{\zeta_B} \cos^2\theta + K_{\beta_B} \sin^2\theta) \phi_z^1 \\ +(K_{\beta_B} - K_{\zeta_B}) \sin\theta \cos\theta \phi_y^1 \\ (K_{\beta_B} - K_{\zeta_B}) \sin\theta \cos\theta \phi_z^1 \\ +(K_{\beta_B} \cos^2\theta + K_{\zeta_B} \sin^2\theta) \phi_y^1 \end{bmatrix} \frac{1}{\Delta} \tag{A.38}$$

where

$$\begin{aligned}
\Delta &= (K_{\zeta_H} + K_{\zeta_B} \cos^2\theta + K_{\beta_B} \sin^2\theta)(K_{\beta_H} + K_{\beta_B} \cos^2\theta + K_{\zeta_B} \sin^2\theta) - (K_{\beta_B} - K_{\zeta_B})^2 \sin^2\theta \cos^2\theta \\
&= K_{\zeta_H} K_{\beta_H} + K_{\zeta_H} (K_{\beta_B} \cos^2\theta + K_{\zeta_B} \sin^2\theta) + K_{\beta_H} (K_{\beta_B} \sin^2\theta + K_{\zeta_B} \cos^2\theta) + K_{\zeta_B} K_{\beta_B}
\end{aligned} \tag{A.39}$$

From Equation (A.38)

$$\phi_z^2 = \frac{1}{\Delta} \{ [K_{\beta_H} (K_{\zeta_B} \cos^2\theta + K_{\beta_B} \sin^2\theta) + K_{\zeta_B} K_{\beta_B}] \phi_z^1 + K_{\beta_H} (K_{\beta_B} - K_{\zeta_B}) \sin\theta \cos\theta \phi_y^1 \} \tag{A.40}$$

and

$$\phi_y^2 = \frac{1}{\Delta} \{ K_{\zeta_H} (K_{\beta_B} - K_{\zeta_B}) \sin\theta \cos\theta \phi_z^1 + [K_{\zeta_H} (K_{\beta_B} \cos^2\theta + K_{\zeta_B} \sin^2\theta) + K_{\beta_B} K_{\zeta_B}] \phi_y^1 \} \quad (A.41)$$

Substituting for ϕ_y^2 , ϕ_z^2 , ϕ_x^2 in terms of ϕ_y^1 , ϕ_z^1 , ϕ_x^1 in equation (A.31), and writing the expressions for M_z^1 , M_y^1 , M_x^1 , one obtains the torsional moment

$$M_x^1 = \frac{K_{\phi_B} K_{\phi_C}}{K_{\phi_B} + K_{\phi_C}} \phi_x^1 \quad (A.42)$$

The flap moment can be written as

$$\begin{aligned} M_y^1 &= \frac{\phi_y^1}{\Delta} \{ K_{\zeta_H} K_{\beta_H} (K_{\beta_B} \cos^2\theta + K_{\zeta_B} \sin^2\theta) + K_{\beta_B} K_{\zeta_B} K_{\beta_H} \} \\ &\quad - \frac{\phi_z^1}{\Delta} (K_{\zeta_B} - K_{\beta_B}) K_{\zeta_H} K_{\beta_H} \cos\theta \sin\theta \end{aligned} \quad (A.43)$$

The lead-lag moment can be expressed as

$$\begin{aligned} M_z^1 &= \frac{\phi_z^1}{\Delta} \{ K_{\zeta_H} K_{\beta_H} (K_{\zeta_B} \cos^2\theta + K_{\beta_B} \sin^2\theta) + K_{\zeta_H} K_{\beta_B} K_{\zeta_B} \} \\ &\quad - \frac{\phi_y^1}{\Delta} (K_{\zeta_B} - K_{\beta_B}) K_{\zeta_H} K_{\beta_H} \sin\theta \cos\theta \end{aligned} \quad (A.44)$$

In the last three equations ϕ_x^1 , ϕ_y^1 , ϕ_z^1 represents angular displacements given at node 1 along X,Y,Z axis. These angular displacements can be related to the flap, lead-lag and torsional rotations of the blade. The flap angle ($-\beta$) is about the undeformed Y-axis, the lead-lag angle (ϕ) is about the Z axis after it has undergone flapping deformation and the torsion (ζ) is along X-axis after the flap and lag deformations have taken place. Resolving these angular displacements along X,Y,Z axis, using equations (A.4) and (A.8) together with the fact that ($-\beta$) is along Y-axis, the components of the angular displacement (or rotation) about the X,Y and Z axis are

$$\begin{aligned} \phi_x^1 &= -\zeta \sin\beta + \phi \cos\beta \cos\zeta \\ \phi_y^1 &= -\beta + \phi \sin\zeta \\ \phi_z^1 &= \zeta \cos\beta + \phi \sin\beta \cos\zeta \end{aligned} \quad (A.45)$$

Introducing the small angle assumptions for β , ζ and ϕ , equations (A.45) become

$$\begin{aligned}\phi_x^1 &= -\zeta\beta + \phi \\ \phi_y^1 &= -\beta + \phi\zeta \\ \phi_z^1 &= \zeta + \phi\beta\end{aligned}\tag{A.46}$$

Substituting these in equations (A.42), (A.43), and (A.44), the elastic moments are obtained

$$\begin{aligned}M_z^1 &= \frac{(\zeta + \phi\beta)}{\Delta} \{K_{\zeta_H} K_{\beta_H} (K_{\zeta_B} \cos^2\theta + K_{\beta_B} \sin^2\theta) + K_{\zeta_H} K_{\beta_B} K_{\zeta_B}\} \\ &+ \frac{(\beta - \phi\zeta)}{\Delta} (K_{\zeta_B} - K_{\beta_B}) K_{\zeta_H} K_{\beta_H} \sin\theta \cos\theta\end{aligned}\tag{A.47}$$

$$\begin{aligned}M_y^1 &= -\frac{(\beta - \phi\zeta)}{\Delta} \{K_{\zeta_H} K_{\beta_H} (K_{\beta_B} \cos^2\theta + K_{\zeta_B} \sin^2\theta) + K_{\beta_B} K_{\zeta_B} K_{\beta_H}\} \\ &- \frac{(\zeta + \phi\beta)}{\Delta} (K_{\zeta_B} - K_{\beta_B}) K_{\zeta_H} K_{\beta_H} \sin\theta \cos\theta\end{aligned}\tag{A.48}$$

$$M_x^1 = \left(\frac{K_{\phi_B} K_{\phi_C}}{K_{\phi_B} + K_{\phi_C}} \right) (\phi - \zeta\beta)\tag{A.49}$$

Equations (A.47), (A.48), and (A.49) can be written in an alternative form, i.e. in terms of equivalent stiffness in flap, lag and torsion respectively.

Defining

$$K_\phi = \frac{K_{\phi_B} K_{\phi_C}}{K_{\phi_B} + K_{\phi_C}}$$

$$K_\beta = \frac{K_{\beta_H} K_{\beta_B}}{K_{\beta_H} + K_{\beta_B}}$$

$$K_\zeta = \frac{K_{\zeta_H} K_{\zeta_B}}{K_{\zeta_H} + K_{\zeta_B}}$$

equations (A.47), (A.48), (A.49) with the superscript 1 deleted, can be written as

$$M_z = \frac{(\zeta + \phi\beta)}{\Delta'} \{K_\zeta - R(K_\zeta - K_\beta) \sin^2\theta\} + \frac{(\beta - \phi\zeta)}{\Delta'} R (K_\zeta - K_\beta) \sin\theta\cos\theta \quad (A.50)$$

$$M_y = - \frac{(\beta - \phi\zeta)}{\Delta'} \{K_\beta + R(K_\zeta - K_\beta) \sin^2\theta\} - \frac{(\zeta + \phi\beta)}{\Delta'} R (K_\zeta - K_\beta) \sin\theta\cos\theta \quad (A.51)$$

$$M_x = K_\phi (\phi - \zeta\beta) \quad (A.52)$$

where

$$R = \frac{1/K_{\beta_B} - 1/K_{\zeta_B}}{(1/K_{\beta_B} + 1/K_{\beta_H}) - (1/K_{\zeta_B} + 1/K_{\zeta_H})}$$

and $\Delta' = 1 + R (1 - R) \sin^2\theta (K_\zeta - K_\beta)^2 / K_\beta K_\zeta$

When the hub stiffness are very large R becomes unity and the moment equations reduce to those obtained previously. When the blade stiffness is very large, R reduces to zero. These moment expressions have to be multiplied by (-1) to obtain the restoring moments of the springs.

Peters [Ref. 14] has given the moment expressions for a spring model including hub flexibility. The torsional degree of freedom was not considered in Ref. 14, thus when substituting $\phi = 0$, equations (A.50) - (A.51) reduce to the equations given by Peters.

Combining the results for an articulated blade and for an elastic blade, general expressions for moment are given below.

The restoring moment in flap is

$$M_y = \frac{(\beta - \phi\zeta)}{\Delta'} \{K_\beta + R(K_\zeta - K_\beta) \sin^2\theta\} + \frac{(\zeta + \phi\beta)}{\Delta'} R (K_\zeta - K_\beta) \sin\theta\cos\theta \quad (A.53)$$

The restoring lead-lag moment is

$$M_z = - \frac{(\zeta + \phi\beta)}{\Delta'} \{K_\zeta - R (K_\zeta - K_\beta) \sin^2\theta\} - \frac{(\beta - \phi\zeta)}{\Delta'} R (K_\zeta - K_\beta) \sin\theta\cos\theta \quad (A.54)$$

The restoring torsional moment is

$$M_x = - K_{\phi_1} (\phi - \zeta\beta) - K_{\phi_2} \phi \quad (A.55)$$

For an articulated blade

$$K_{\beta} = K_{\zeta} = K_{\phi_1} = 0 \quad \text{and} \quad K_{\phi_2} = \frac{K_{\phi_C} K_{\phi_B}}{K_{\phi_C} + K_{\phi_B}}$$

For a hingeless blade $K_{\phi_2} = 0$

$$K_{\beta} = \frac{K_{\beta_H} K_{\beta_B}}{K_{\beta_H} + K_{\beta_B}} \quad ; \quad K_{\zeta} = \frac{K_{\zeta_H} K_{\zeta_B}}{K_{\zeta_H} + K_{\zeta_B}} \quad ; \quad K_{\phi_1} = \frac{K_{\phi_C} K_{\phi_B}}{K_{\phi_C} + K_{\phi_B}}$$

$$R = \frac{1/K_{\beta_B} - 1/K_{\zeta_B}}{(1/K_{\beta_B} + 1/K_{\beta_H}) - (1/K_{\zeta_B} + 1/K_{\zeta_H})}$$

$$\text{and } \Delta' = 1 + R (1 - R) \sin^2 \theta (K_{\zeta} - K_{\beta})^2 / K_{\zeta} K_{\beta}$$

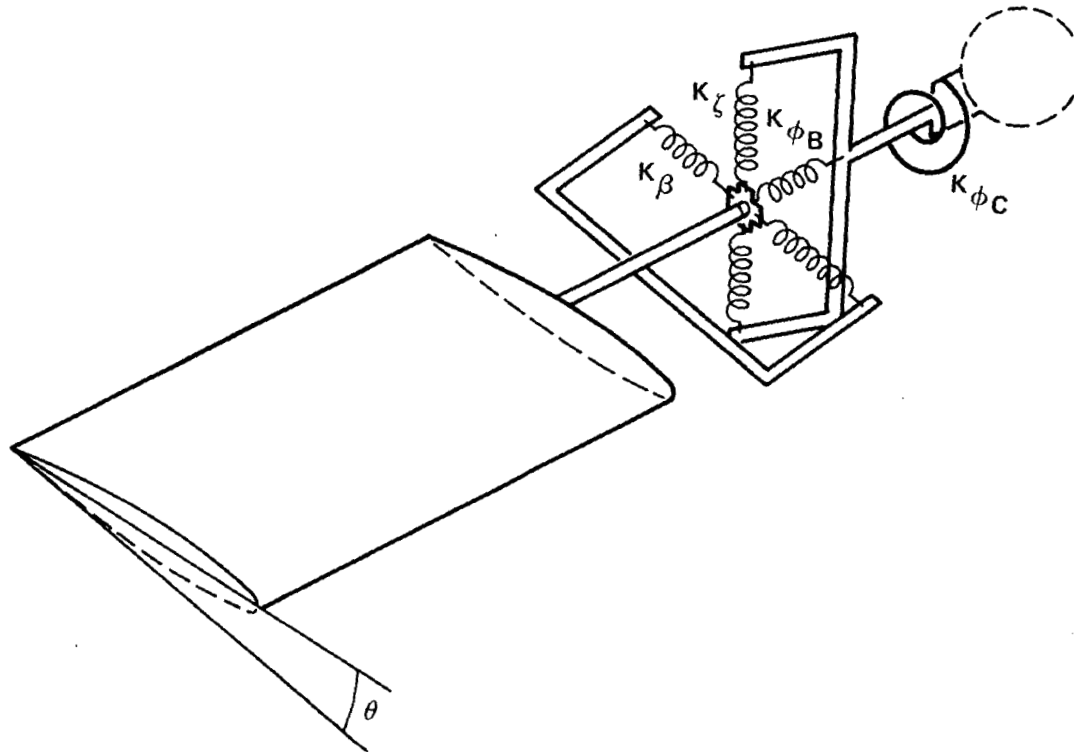

Figure A1. Equivalent Spring Restrained Blade Model

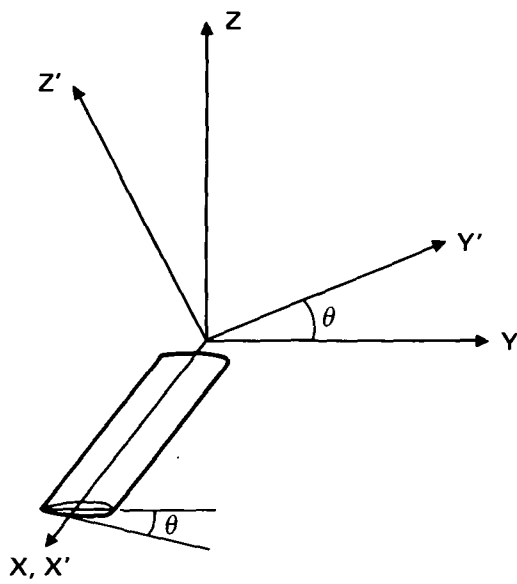

Figure A2. Undeformed Axes

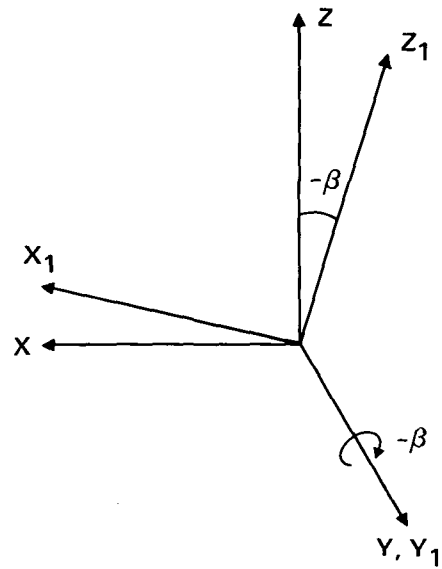

Figure A3 Flap Angle

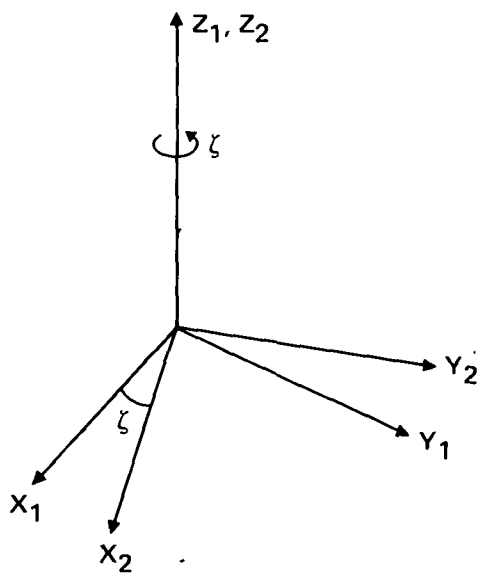

Figure A4. Lead-Lag Angle

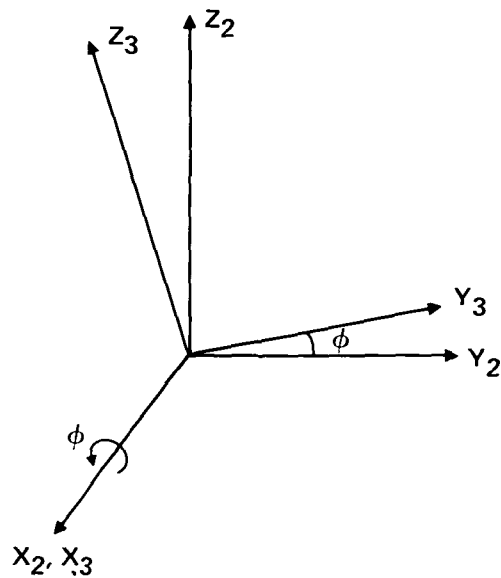

Figure A5. Torsion Angle

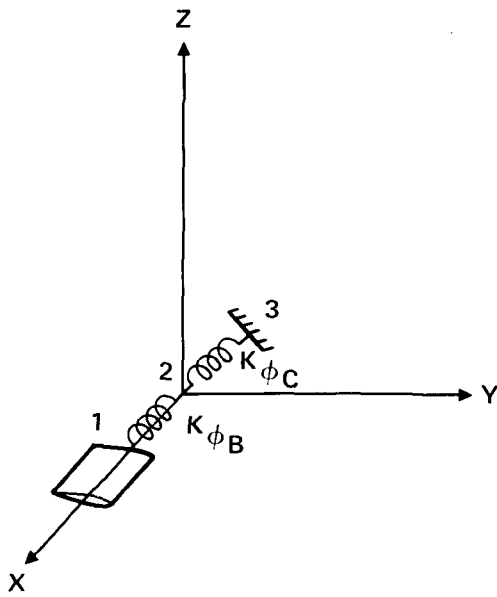

Figure A6. Articulated Blade Model

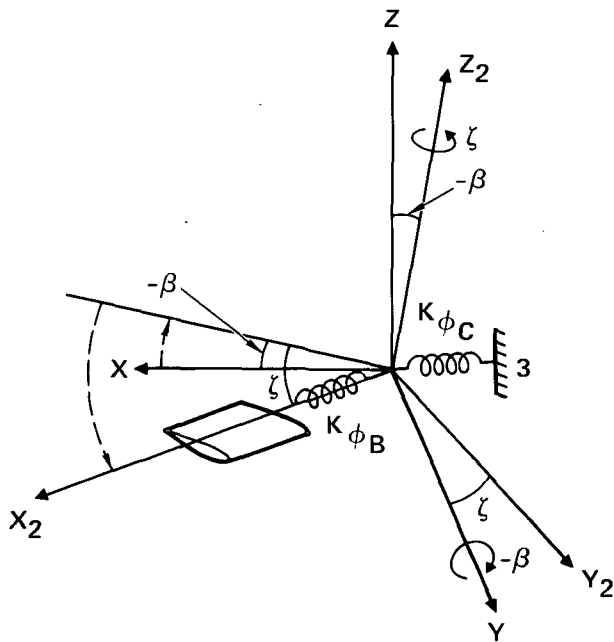

Figure A7. Orientation of the Deformed Blade After Flap and Lag Motion

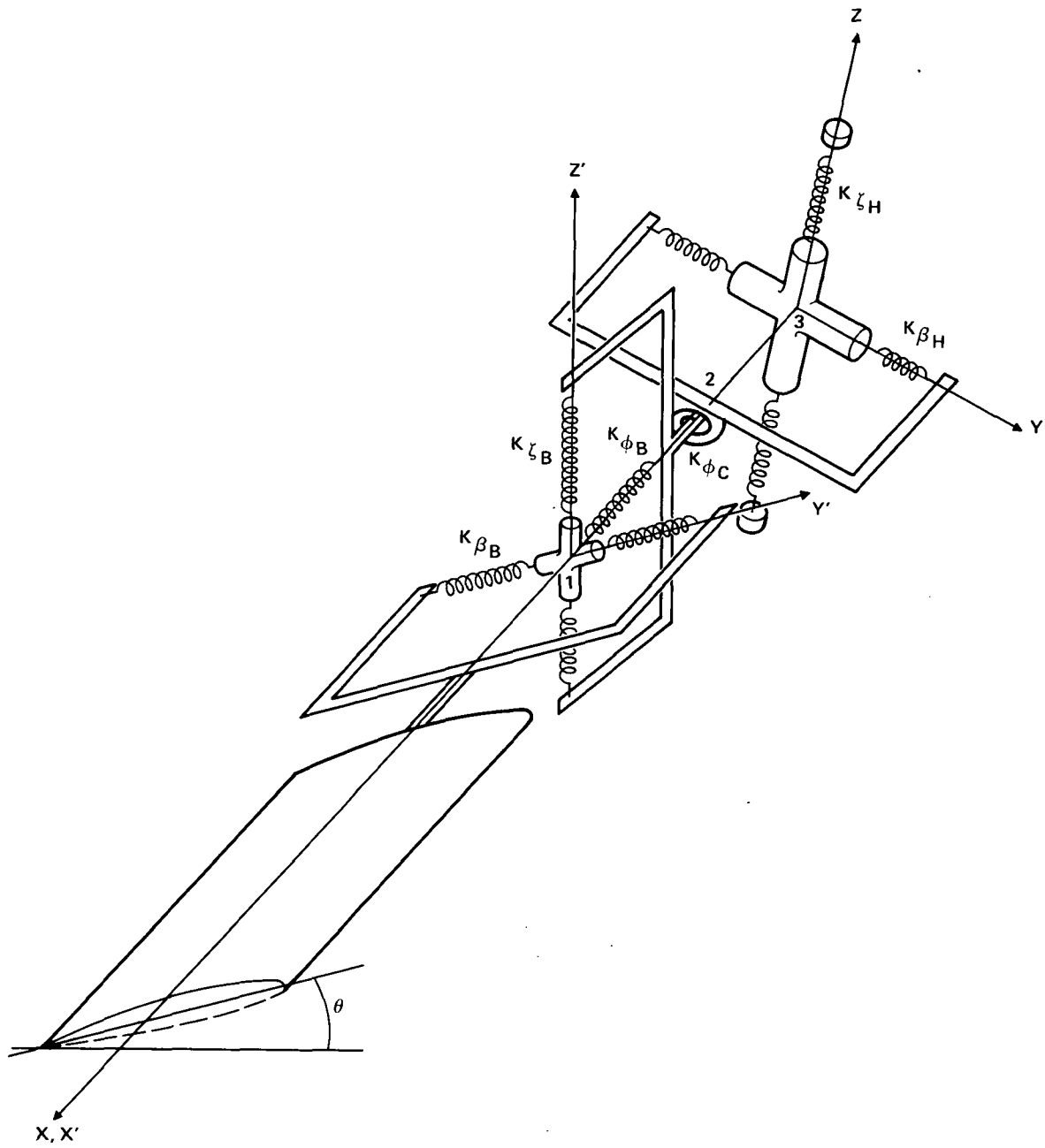

Figure A8. Equivalent Spring Restrained Blade Model With Hub Flexibility

1. Report No. NASA CR-3822		2. Government Accession No.		3. Recipient's Catalog No.	
4. Title and Subtitle AEROELASTIC EFFECTS IN MULTI-ROTOR VEHICLES WITH APPLICATION TO A HYBRID HEAVY LIFT SYSTEM. PART I: FORMULATION OF EQUATIONS OF MOTION				5. Report Date August 1984	
				6. Performing Organization Code	
7. Author(s) C. Venkatesan and P. Friedmann				8. Performing Organization Report No.	
9. Performing Organization Name and Address University of California Mechanics & Structures Dept. Los Angeles, CA 90024				10. Work Unit No. T3516Y	
				11. Contract or Grant No. NAG2-116	
				13. Type of Report and Period Covered	
12. Sponsoring Agency Name and Address National Aeronautics and Space Administration Washington, DC 20546				14. Sponsoring Agency Code 505-42-51	
15. Supplementary Notes Technical Monitor: Dr. H. Miura, M/S 237-11 NASA Ames Research Center, Moffett Field, CA. 94035 Topical Report					
16. Abstract This report presents a set of governing coupled differential equations for a model of a hybrid aircraft. The model consists of multiple rotor systems connected by an elastic interconnecting structure, with options to add any combination of or all of the following components; i.e., thrusters, a buoyant hull, and an underslung weight. The dynamic equations are written for the individual blade with hub motions, for the rigid body motions of the whole model, and also for the flexible modes of the interconnecting structure. One of the purposes of this study is to serve as the basis of a numerical study aimed at determining the aeroelastic stability and structural response characteristics of a Hybrid Heavy Lift Airship (HHLA). It is also expected that the formulation may be applicable to analyzing stability and responses of dual rotor helicopters such as a Heavy Lift Helicopter (HLH). Furthermore the model is capable of representing coupled rotor/body aeromechanical problems of single rotor helicopters.					
17. Key Words (Suggested by Author(s)) Rotary wing aeroelasticity Rotor dynamics Multirotor systems Aeromechanical stability			18. Distribution Statement Unclassified - Unlimited Subject Category 08		
19. Security Classif. (of this report) Unclassified		20. Security Classif. (of this page) Unclassified		21. No. of Pages 145	22. Price* A07

National Aeronautics and
Space Administration

Washington, D.C.
20546

Official Business

Penalty for Private Use, \$300

THIRD-CLASS BULK RATE

Postage and Fees Paid
National Aeronautics and
Space Administration
NASA-451



NASA

POSTMASTER: If Undeliverable (Section 158
Postal Manual) Do Not Return
