

NASA Contractor Report 3828

NASA-CR-3828 19840023147

Investigation, Development, and Application of Optimal Output Feedback Theory

*Volume I—A Convergent Algorithm for
the Stochastic Infinite-Time Discrete
Optimal Output Feedback Problem*

Nesim Halyo and John R. Broussard

CONTRACT NAS1-15759
AUGUST 1984

FOR REFERENCE

FOR REFERENCE ONLY

LIBRARY COPY

SEP 1984

LANGLEY RESEARCH CENTER
LIBRARY, NASA
HAMPTON, VIRGINIA

NASA



NASA Contractor Report 3828

Investigation, Development, and Application of Optimal Output Feedback Theory

*Volume I—A Convergent Algorithm for
the Stochastic Infinite-Time Discrete
Optimal Output Feedback Problem*

Nesim Halyo and John R. Broussard
*Information & Control Systems, Incorporated
Hampton, Virginia*

Prepared for
Langley Research Center
under Contract NAS1-15759



National Aeronautics
and Space Administration

Scientific and Technical
Information Branch

1984



FOREWORD

The work described in this report was performed by Information & Control Systems, Incorporated under Contract Number NAS1-15759 for the National Aeronautics and Space Administration, Langley Research Center, Hampton, Virginia. The work was sponsored by the Flight Control Systems Division, Applied Controls Branch at Langley Research Center. Mr. R. M. Hueschen was the NASA Technical Representative monitoring this contract. Dr. N. Halyo directed the technical effort at ICS.

ABSTRACT

This report considers the stochastic, infinite-time, discrete output feedback problem for time-invariant linear systems. Two sets of sufficient conditions for the existence of a stable, globally optimal solution are presented. An expression for the total change in the cost function due to a change in the feedback gain is obtained. This expression is used to show that a sequence of gains can be obtained by an algorithm, so that the corresponding cost sequence is monotonically decreasing and the corresponding sequence of the cost gradients converges to zero. The algorithm is guaranteed to obtain a critical point of the cost function. The computational steps necessary to implement the algorithm on a computer are presented. The results are applied to a digital outer-loop flight control problem. The numerical results for this 13th order problem indicate a rate of convergence considerably faster than two other algorithms used for comparison when they converge.

TABLE OF CONTENTS

	page
FOREWORD	iii
ABSTRACT	iv
LIST OF TABLES	vi
I. INTRODUCTION	1
II. PROBLEM FORMULATION.	4
III. EXISTENCE OF A SOLUTION.	7
IV. INCREMENTAL COST AND NECESSARY CONDITIONS.	18
V. DEVELOPMENT OF THE ALGORITHM	20
VI. APPLICATION TO AN AIRCRAFT OUTER-LOOP DIGITAL CONTROL DESIGN PROBLEM	27
VII. CONCLUSIONS.	30
REFERENCES	32
APPENDIX PROOF OF THEOREM 1	35

LIST OF TABLES

	page
TABLE 1. EFFECTS OF CHANGING NOISE COVARIANCE	
MATRICES	48
TABLE 2. DIAGONAL ELEMENTS OF DESIGNED MATRICES . . .	49
TABLE 3. ALGORITHM COMPARISONS.	49

I. INTRODUCTION

Various formulations of the optimal output feedback problem have received considerable attention over the last two decades [1] - [21]. Loosely, the problem consists of finding a control law optimal with respect to a (usually) quadratic cost function, for a given linear system when the control is constrained to be linear in the instantaneous "outputs" i.e., a specified set of measurements or states. Various forms of the problem correspond to whether the system is continuous or discrete, stochastic or deterministic, whether the optimization interval is finite or infinite, and whether the control law and system are time-invariant or time-varying. More subtle variations of the problem, such as the specific treatment of white measurement noise in continuous problems (e.g., compare [11] and [12]), have also been formulated.

The optimal output feedback problem is a significant extension of the optimal quadratic "full state feedback" problem, [22]. The optimal output feedback formulation addresses some of the limitations encountered in practical systems and provides a flexibility useful in configuring the control law for ease of implementation. In many cases involving complex, high order systems, all the states are not measured. Optimal output feedback provides a method of designing simple control laws for such situations. More importantly, output feedback provides a method of designing control laws in cases where it is desirable not to feed back some states, even if measurements are available. For example, in a complex system such as an aircraft, the aircraft's aerodynamics are coupled with subsystems, such as engine dynamics and hydraulic systems, which drive the control actuators. It is often desirable not to feed back all the subsystem states, (e.g., the hydraulic fuel flow rate) in order to track a specified flight path.

Optimal output feedback provides a modern control alternative to the classical frequency-domain methods of designing simple, low order dynamic compensators and outer-loop compensators (i.e., major/minor loop compensation [23]). It is well known that the fixed order dynamic compensator problem can be imbedded in the output feedback problem [6], [8]. A major design flexibility is therefore gained using optimal output feedback when compared to the LQG approach which results in a full order Kalman filter as a dynamic compensator.

The stochastic output feedback problem provides a systematic approach for increasing or decreasing specific sets of feedback gains by appropriately varying the measurement and plant noise covariances. This flexibility is due to the fact that the separation of estimation and control present in the LQG solution does not hold for the optimal stochastic output feedback problem. Thus, if a measurement is noisy, the fact that part of this noise will be introduced into the system through the control is recognized, and the corresponding gains are automatically reduced. Output feedback has various other advantages which are often useful in practical control designs.

The necessary conditions for the various formulations of the optimal output feedback problem are well-known, [1] - [13]. The resulting equations are coupled non-linear matrix equations. Various algorithms to solve these equations have been suggested. These algorithms include sequentially solving the non-linear matrix equations as in [4], sequentially solving a set of linear matrix equations as in [5] and [13], gradient based searches to reach the cost function minimum as in [14], [17] - [19], and non-gradient based search procedures as in [15] and [21]. It is recognized that the sequential algorithms are "fast" when compared to the search algorithms, [21], but their convergence is, at best, not guaranteed [20]. The search algorithms can converge to a critical point, [19], [17], but require large amounts of computation

time that increase significantly as the order of the plant increases. The unavailability of a fast, convergent and numerically reliable algorithm has, in the authors' opinion, been a major hindrance to the successful application of the optimal output feedback design approach.

This report considers the stochastic, infinite-time, discrete, output feedback problem for time-invariant linear systems. The problem is formulated in Section II. Sufficient conditions for the existence of a stable globally optimal solution to the infinite time optimization problem is presented in Section III. Section IV presents necessary conditions for an output feedback gain to minimize the infinite time quadratic optimization cost function. Also shown in Section IV is an exact expression for the change in the value of the cost function due to a change in the output feedback gain. This exact expression is used in Section V to show that a sequence of gains, defined by an algorithm, monotonically decreases the infinite time quadratic cost function while correspondingly causing the gradient of the cost function to approach zero. The algorithm can be started from any stabilizing gain (i.e., any gain which stabilizes the closed-loop system) and is guaranteed to obtain a critical point. However, as with the other algorithms mentioned, this critical point need not be a global minimum of the cost function. The steps in the algorithm are given at the end of Section V. An outer-loop digital control problem is used in Section VI to compare the algorithm to other methods for obtaining the optimal output feedback gain. Output feedback gain variations with different choices for the measurement noise and process noise covariance are also shown in the example in Section VI. The numerical results for this 13th order system confirm the convergence properties and indicate a rate of convergence considerably faster than the other algorithms tested when the latter converge.

II. PROBLEM FORMULATION

Consider the discrete, time-invariant, stochastic system described by

$$x_{k+1} = \phi x_k + \Gamma u_k + w_k, \quad k \geq 0, \quad (1)$$

$$y_k = C x_k + v_k, \quad (2)$$

where x_k , y_k , u_k represent the state, measurement (output), control vectors, respectively, and w_k , v_k are the plant, measurement noise vectors, respectively, satisfying the conditions

$$E(w_k) = 0, \quad E(w_k w_j')^1 = \hat{W} \delta_{kj}, \quad (3)$$

$$E(v_k) = 0, \quad E(v_k v_j') = \hat{V} \delta_{kj}, \quad (4)$$

$$E(w_k v_j') = E(w_k x_j') = E(v_k x_j') = 0, \quad E(x_0 x_0') = S_0. \quad (5)$$

The class of control laws considered is restricted to be of the form

$$u_k = -K y_k \quad (6)$$

i.e., the feedback of measurements or selected state components through a constant gain. It should be noted that it is not necessary that the noise covariance, \hat{W} and \hat{V} , be positive definite or that the mean of the initial condition, x_0 , be zero, although some of these conditions may be used to show specific properties of the optimal solution. Now consider a cost function of the form

$$\bar{J}_N(K) = \frac{1}{2} E\left(\sum_{i=0}^N x_{i+1}' Q x_{i+1} + u_i' R u_i\right), \quad N \geq 0 \quad (7)$$

For the case of a deterministic system (i.e., $\hat{W} = 0$, $\hat{V} = 0$), as $N \rightarrow \infty$,

¹ The prime, " ' ", denotes the transpose of a vector or matrix.

$\bar{J}_N(K)$ remains finite when the control law, (6), stabilizes the system. However, in the stochastic case, $\bar{J}_N(K)$ grows without bounds (except for some trivial cases) as can be seen by the inequality

$$E(x'_{i+1} Q x_{i+1} + u'_i R u_i) \geq \text{tr} \{ Q W \} + \text{tr} \{ K' R K \hat{V} \} \geq 0, \quad i \geq 0. \quad (8)$$

Thus, to treat the infinite optimization interval for the stochastic case, it is necessary to modify the cost function. A natural selection is to consider the average cost

$$J_N(K) = \frac{1}{2(N+1)} E\left(\sum_{i=0}^N x'_{i+1} Q x_{i+1} + u'_i R u_i\right), \quad N \geq 0, \quad (9)$$

$$J(K) = \lim_{N \rightarrow \infty} J_N(K), \quad K \in \mathcal{D}, \quad (10)$$

where \mathcal{D} is the set of K 's for which the limit in (10) exists and is finite.

Note that $J_N(K)$ and $\bar{J}_N(K)$ are equivalent for optimization; i.e., the optimal control gain for both cost functions is the same. However, as shown in Lemma 2, the limit in (10) exists and is finite when the closed-loop system is stable.

In the remainder of this report, it will be assumed that Q and R are non-negative definite, unless specified otherwise. Lemma 1 is given without proof for completeness.

Lemma 1

Consider the system defined by (1) - (6). Then,

$$\begin{aligned} \bar{J}_N(K) = & \frac{1}{2} \text{tr} \left\{ (P_{N+1}(K) - Q) S_o + \sum_{i=0}^N P_i(K) \hat{W} \right\} \\ & + \frac{1}{2} \text{tr} \left\{ \sum_{i=0}^N K' (\Gamma' P_i(K) \Gamma + R) K \hat{V} \right\}, \quad N \geq 0 \end{aligned} \quad (11)$$

where

$$P_{i+1}(K) = \phi(K)' P_i(K) \phi(K) + C' K' R K C + Q, \quad P_o(K) = Q, \quad (12)$$

$$\phi(K) = \phi - \Gamma K C. \quad (13)$$

Furthermore, $P_i(K) \uparrow P(K) < \infty$ if $\rho(\phi(K)) < 1$.²

The necessary conditions for the finite optimization interval, can be obtained from (11) and (12) by usual methods [10]. For the infinite optimization interval, it is necessary to obtain a suitable expression for $J(K)$.

Lemma 2

If $\rho(\phi(K)) < 1$, $J(K)$ is finite and is given by

$$J(K) = \frac{1}{2} \text{tr} \left\{ P(K) \hat{W} \right\} + \frac{1}{2} \text{tr} \left\{ K' (\Gamma' P(K) \Gamma + R) K \hat{V} \right\}, \quad (14)$$

$$P(K) = \phi(K)' P(K) \phi(K) + C' K' R K C + Q. \quad (15)$$

Proof: From (9), (10), and (11),

$$J(K) = \frac{1}{2} \lim_{N \rightarrow \infty} \text{tr} \left\{ \frac{P_{N+1}(K)}{N+1} S_o + \frac{1}{N+1} \sum_{i=0}^N P_i(K) \hat{W} \right\} \\ + \text{tr} \left\{ K' (\Gamma' \frac{1}{N+1} \sum_{i=0}^N P_i(K) \Gamma + R) K \hat{V} \right\}. \quad (16)$$

By Lemma 1, $P_{N+1}(K)$ converges (to a finite matrix); hence, it is bounded, so that the term depending on S_o vanishes as $N \rightarrow \infty$. Since $P_i(K)$ is bounded and convergent, it can be shown that

$$\lim_{N \rightarrow \infty} \frac{1}{N+1} \sum_{i=0}^N P_i(K) = P(K). \quad (17)$$

Substituting (17) into (16) results in the desired expression.

Thus, the cost $J(K)$ (and $P(K)$) is finite on the set S of stabilizing feedback gains:

$$S = \{ K | \rho(\phi(K)) < 1 \}. \quad (18)$$

² $\rho(\phi(K))$ denotes the spectral radius of $\phi(K)$.

If the system (ϕ, Γ, C) is output stabilizable, then S (hence \mathcal{D}) is not empty, so that the optimization problem is well-defined, and will be posed as: Find a K^* in S such that

$$J(K^*) \leq J(K), \quad K \in S \quad (19)$$

It should be noted that this formulation, (19), of the optimization problem guarantees that a solution, when it exists, stabilizes the closed-loop system, by restricting the minimization to S . While most problems can be treated with this formulation, some cases of practical significance [24] require that the minimization be performed over \mathcal{D} . This class of problems will be treated in future research.

Although the cost function selected here does not contain the cross-coupling term between state and control which arises in sampled-data problems, it is well-known that (e.g., [25]) a simple linear transformation reduces this case to the one considered in this report. Thus, the results obtained here apply equally to the sampled-data formulation.

III. EXISTENCE OF A SOLUTION

This section considers sufficient conditions for the existence of a solution to the optimal control problem posed; i.e., a global minimum in S . An effort is made to obtain conditions which are simple to verify and cover a large class of systems. The existence conditions obtained are given in Theorems 2 and 3. Since the stability set S , over which the minimization is to take place, is an open and sometimes unbounded set, output stabilizability alone does not guarantee the existence of a stable solution. To guarantee a solution, it is necessary to determine conditions under which the optimal gain is an interior point of S . This is achieved in the following, by

determining conditions which guarantee that the optimal cost is attained by a gain belonging to a closed and bounded subset of S . The required conditions are given in Lemmas 7 and 8. First, it is of interest to show the continuity of the cost $J(K)$.

Lemma 3

$J(K)$ and $P(K)$ are continuous on S .

Proof: From (14), note that $J(K)$ is continuous if $P(K)$ is continuous. Thus, let $K, K + \Delta K \in S$; manipulating (15),

$$\begin{aligned} \Delta P(K, \Delta K) &= P(K + \Delta K) - P(K) & (20) \\ &= \phi(K)' \Delta P(K, \Delta K) \phi(K) \\ &+ C' \Delta K' (R K C - \Gamma' P(K + \Delta K) \phi(K)) \\ &+ (R K C - \Gamma' P(K + \Delta K) \phi(K))' \Delta K C \\ &+ C' \Delta K' (\Gamma' P(K + \Delta K) \Gamma + R) \Delta K C & (21) \end{aligned}$$

Now, let $3\varepsilon = 1 - \rho(\phi(K)) > 0$, and select a matrix norm, say $\|\bullet\|$, such that

$$\|\phi(K)\| < \rho(\phi(K)) + \varepsilon < 1. \quad (22)$$

Using (22) and (21), it can be shown that

$$\begin{aligned} \|\Delta P(K, \Delta K)\| &\leq \frac{1}{1 - \|\phi(K)\|^2} \left[\begin{aligned} &\| C' \Delta K' (R K C - \Gamma' P(K + \Delta K) \phi(K)) \\ &+ (R K C - \Gamma' P(K + \Delta K) \phi(K)) \Delta K C \\ &+ C' \Delta K' (\Gamma' P(K + \Delta K) \Gamma + R) \Delta K C \| \end{aligned} \right] & (23) \end{aligned}$$

As can be seen from (23), if $P(K + \Delta K)$ is bounded in some neighborhood of K , then P is continuous at K . Using (22) and (15)

$$\| P(K + \Delta K) \| \leq \frac{1}{1 - \| \phi(K + \Delta K) \|^2} \| C' (K + \Delta K)' R(K + \Delta K) C + Q \| ,$$

$$\| \phi(K + \Delta K) \| < 1 \quad (24)$$

Since the norm is a continuous function of the matrix elements, the set $\{K + \Delta K \in S \mid \| \phi(K + \Delta K) \| \leq 1 - \epsilon, \text{ and } \| \Delta K \| \leq \delta\}$, for some positive δ , is a closed neighborhood of K over which $P(K + \Delta K)$ is bounded. Thus, from (23)

$$\lim_{\Delta K \rightarrow 0} \| \Delta P(K, \Delta K) \| = 0, \quad K \in S \quad (25)$$

so that $P(K)$ and $J(K)$ are continuous at K .

Since S is an open set, and is not necessarily bounded, it is necessary to determine conditions under which the infimum of $J(K)$ is attained at some $K^* \in S$; i.e., sufficient conditions for the existence of an optimal solution. First note the following significant property of output stabilizable systems, whose proof is given in the Appendix.

Theorem 1

Let (C, ϕ, Γ) be output stabilizable. Then $C \phi^k \Gamma \rightarrow 0$ if, and only if, $\rho(\phi) < 1$.

Loosely, this property of output stabilizable systems states that the unstable modes of the system must be simultaneously observed in the output (which is used for feedback), and excited (or reachable) by the control which will stabilize the system.

Definition

$$j_N(K) = \frac{1}{2} \text{tr} \{ \bar{P}_N(K) \hat{W} \} + \text{tr} \{ K' (\Gamma' \bar{P}_N(K) \Gamma + R) K \hat{V} \} , \quad (26)$$

$$\bar{P}_N(K) = \frac{1}{N+1} \sum_{i=0}^N P_i(K) . \quad (27)$$

The difference between $j_N(K)$ and the cost $J_N(K)$ is the term depending on the initial covariance S_0 , as can be seen from

$$J_N(K) = j_N(K) + \frac{1}{2(N+1)} \text{tr} \{ (P_N(K) - Q) S_0 \} \quad (28)$$

However, it is preferable to work with $j_N(K)$ due to its monotonicity, as shown in the following lemma.

Lemma 4

For any gain K , $j_N(K)$ is non-decreasing; i.e.,

$$0 \leq j_N(K) \leq j_{N+1}(K) . \quad (29)$$

Proof: By Lemma 1, $P_N(K)$ is non-decreasing. It follows that $\bar{P}_N(K)$ is also non-decreasing, since

$$\bar{P}_{N-1}(K) \leq P_{N-1}(K) \leq P_N(K) \quad (30)$$

$$\begin{aligned} \bar{P}_N(K) &= \frac{N}{N+1} \bar{P}_{N-1}(K) + \frac{1}{N+1} P_N(K) \geq \frac{N}{N+1} \bar{P}_{N-1}(K) \\ &\quad + \frac{1}{N+1} \bar{P}_{N-1}(K) = \bar{P}_{N-1}(K) \end{aligned} \quad (31)$$

It follows that $\bar{P}_N(K)$ and $K'(\Gamma' \bar{P}_N(K) \Gamma + R) K$ are both non-decreasing.

Using Lemma A5 in the Appendix, we obtain the desired result given by (29).

Lemma 5

Let $K_i \rightarrow K$, $K_i \in S$. Then for each $\epsilon > 0$ and integer N , there is an integer i_N such that

$$j_N(K) \leq j(K_{i_N}) + \epsilon . \quad (32)$$

Proof: Note that j_N is a continuous function of K over R^{rm} . Hence,
 $j_N(K_i) \rightarrow j_N(K)$, $K \in R^{rm}$. Thus, given N and $\epsilon > 0$, there is an integer, say
 i_N , such that whenever $i \geq i_N$

$$|j_N(K) - j_N(K_i)| \leq \epsilon \quad (33)$$

$$j_N(K_i) - \epsilon \leq j_N(K) \leq j_N(K_i) + \epsilon \leq j(K_i) + \epsilon \quad (34)$$

Corollary 1

Let $K_i \in S$, $K_i \rightarrow K$. Then

$$1) \text{ if } j(K_i) \text{ is bounded by } B, \text{ then } j_N(K) \uparrow j(K) \leq B \quad (35)$$

$$2) \text{ if } j(K_i) \rightarrow j^*, \text{ then } j_N(K) \uparrow j(K) \leq j^* \quad (36)$$

$$3) \text{ if } j_N(K) \uparrow \infty, \text{ then } j(K_i) \text{ is not bounded.} \quad (37)$$

Proof: 1) let $j(K_i) \leq B$, then for $\epsilon > 0$

$$j_N(K) \leq j(K_i) + \epsilon \leq B + \epsilon \quad (38)$$

$$\therefore j(K) \leq B + \epsilon, \quad \forall \epsilon > 0 \quad (39)$$

(35) follows, by letting $\epsilon \rightarrow 0$.

2) Let $j(K_i) \rightarrow j^*$. Then, for any subsequence $\{K_{i_N}, N \geq 0\}$, $j(K_{i_N}) \rightarrow j^*$;
hence as $N \rightarrow \infty$ (32) results in

$$j(K) < j^* + \epsilon. \quad \forall \epsilon > 0 \quad (40)$$

As $\epsilon \downarrow 0$, (36) follows.

3) If $j_N(K) \uparrow \infty$, then $j(K_{i_N}) \uparrow \infty$; so that $j(K_i)$ cannot be bounded.

Lemma 6

Let (C, ϕ, Γ) be output stabilizable, $Q \geq \epsilon C'C$, $\hat{W} \geq \epsilon \Gamma \Gamma'$ for some $\epsilon > 0$. Then $J_N(K) \geq j_N(K) \uparrow \infty$, $K \notin S$.

Proof: Recall that

$$P_N(K) = \phi^N(K)' Q \phi^N(K) + \sum_{i=0}^{N-1} \phi^i(K)' (Q + C' K' R K C) \phi^i(K) \quad (41)$$

Now note that

$$\begin{aligned} \text{tr} \{ P_N(K) \hat{W} \} &\geq \text{tr} \left\{ \sum_{i=0}^N \phi^i(K)' Q \phi^i(K) \hat{W} \right\} \\ &\geq \text{tr} \left\{ \epsilon \sum_{i=0}^N \phi^i(K)' C' C \phi^i(K) \hat{W} \right\} \end{aligned} \quad (42)$$

$$\begin{aligned} &\geq \epsilon \text{tr} \left\{ \sum_{i=0}^N C \phi^i(K) \hat{W} \phi^i(K)' C' \right\} \\ &\geq \epsilon^2 \sum_{i=0}^N \text{tr} \left\{ C \phi^i(K) \Gamma \Gamma' \phi^i(K)' C' \right\} \end{aligned} \quad (43)$$

By Theorem 1, it follows that whenever $K \notin S$, the N^{th} term of the series in (43), i.e., $\text{tr} \{ C \phi^N(K) \Gamma \Gamma' \phi^N(K)' C' \}$ does not tend to zero; hence the series increases without bound. It follows that

$$\text{tr} \{ P_N(K) \hat{W} \} \uparrow \infty \quad (44)$$

$$j_N(K) \geq \frac{1}{2} \text{tr} \{ \bar{P}_N(K) \hat{W} \} = \frac{1}{2(N+1)} \sum_{i=0}^N \text{tr} \{ P_i(K) \hat{W} \} \uparrow \infty \quad (45)$$

Since $j_N(K)$ is monotonic, using (28) the desired result follows.

Lemma 6 can be interpreted as stating that, for an output stabilizable system, if each output variable is penalized and each control variable is corrupted by noise, then the cost is infinite unless the closed-loop system is stable. Thus, the optimal gain, if one exists, has to stabilize the system. Conversely, if each output variable is penalized and each control variable is

corrupted by noise, the stability of the closed-loop system is determined completely by whether the cost is finite or not. Note that, in this case, $\mathcal{D} = S$.

Lemma 7

Let (C, ϕ, Γ) be output stabilizable and for some $\varepsilon > 0$, let $Q \geq \varepsilon C' C$, $\hat{W} \geq \varepsilon \Gamma \Gamma'$. Then $S(a) = \{K \in S \mid J(K) \leq a\}$, $a \in \mathbb{R}$ is closed.

Proof: Let $K_i \in S(a)$, and $K_i \rightarrow K$. If $K \notin S$, then (by Lemma 6) $j_N(K) \uparrow \infty$, so that by part (3) of Lemma 5, $J(K_i) \geq j(K_i)$ is not bounded, a contradiction. Hence, $K \in S$. Since J is continuous on S , $a \geq J(K_i) \rightarrow J(K) \leq a$; $\therefore K \in S(a)$

Lemma 8

If $(\Gamma' Q \Gamma + R) > 0$ and $(C \hat{W} C' + \hat{V}) > 0$, then $S(a) = \{K \in S \mid J(K) \leq a\}$ is bounded, $a \in \mathbb{R}$.

Proof: Suppose for some $a \in \mathbb{R}$, $S(a)$ is unbounded. Then it contains an unbounded increasing sequence, say $\{K_i\} \subset S(a)$. Now note that, using identities on the trace, the cost $J(K)$ can be rewritten as

$$J(K) = \frac{1}{2} \text{tr} \{Q S(K)\} + \frac{1}{2} \text{tr} \{R K(C S(K) C' + \hat{V}) K'\}, \quad K \in S \quad (46 \text{ a})$$

$$S(K) = \phi(K) S(K) \phi(K)' + \Gamma K \hat{V} K' \Gamma' + \hat{W}, \quad K \in S \quad (46 \text{ b})$$

Now let $\hat{P}(K) = \Gamma' P(K) \Gamma + R$, $\hat{S}(K) = C S(K) C' + \hat{V}$, and note that

$$2J(K_i) = \text{tr} \{P(K_i) \hat{W}\} + \text{tr} \{K_i' \hat{P}(K_i) K_i \hat{V}\} \leq 2a \quad (47 \text{ a})$$

$$2J(K_i) = \text{tr} \{Q S(K_i)\} + \text{tr} \{R K_i \hat{S}(K_i) K_i'\} \leq 2a \quad (47 \text{ b})$$

Note that $\hat{P}(K) \geq \Gamma' Q \Gamma + R$, $\hat{S}(K) \geq C \hat{W} C' + \hat{V}$, $P(K) \geq \phi(K)' Q \phi(K)$. Thus,

$$\text{tr} \{K_i' (\Gamma' Q \Gamma + R) K_i \hat{V}\} \leq 2a, \quad (48)$$

$$\text{tr} \left\{ R K_i (C \hat{W} C' + \hat{V}) K_i' \right\} \leq 2a, \quad (49)$$

$$\text{tr} \left\{ \phi(K_i)' Q \phi(K_i) \hat{W} \right\} \leq 2a. \quad (50)$$

$$\text{tr} \left\{ \frac{K_i'}{\|K_i\|} (\Gamma' Q \Gamma + R) \frac{K_i}{\|K_i\|} \hat{V} \right\} \leq 2a / \|K_i\|^2 \downarrow 0; \quad (51)$$

Since $\left\{ \frac{K_i}{\|K_i\|} \right\}$ is bounded it has a limit point, say K , such that $\|K\| = 1$ and

$$\text{tr} \left\{ K' (\Gamma' Q \Gamma + R) K \hat{V} \right\} = 0. \quad (52)$$

Similarly,

$$\text{tr} \left\{ R K (C \hat{W} C' + \hat{V}) K' \right\} = 0, \quad (53)$$

$$\text{tr} \left\{ K' \Gamma' Q \Gamma K C \hat{W} C' \right\} = 0, \quad (54)$$

where (54) follows from (50) by noting that $-\Gamma K C$ is a limit point of $\left\{ \phi(K_i) / \|K_i\| \right\}$. Thus, unless some $K \neq 0$ satisfies (52), (53) and (54), $S(a)$ is bounded. Now (52) - (54) can be manipulated to obtain

$$\text{tr} \left\{ K' (\Gamma' Q \Gamma + R) K (C \hat{W} C' + \hat{V}) \right\} = 0. \quad (55)$$

The desired result follows by noting that when $(\Gamma' Q \Gamma + R)$ and $(C \hat{W} C' + \hat{V})$ are positive definite, the unique solution of (55) is $K = 0$; so that $S(a)$ cannot be unbounded.

Theorem 2

Let (C, ϕ, Γ) be output stabilizable, $(\Gamma' Q \Gamma + R)$ and $(C \hat{W} C' + \hat{V})$ be positive definite, and for some $\varepsilon > 0$, $Q \geq \varepsilon C' C$, $\hat{W} \geq \varepsilon \Gamma \Gamma'$. Then there exists a $K^* \in S$ such that

$$J(K^*) \leq J(K), \quad K \in S.$$

Proof: Let $J^* = \inf_{K \in S} J(K) < \infty$. Necessarily, there is a sequence $K_i, i \geq 0$ in S such that $J(K_i) \downarrow J^*$. By Lemma 8, $S_0 = \{K \in S | J(K) \leq J(K_0)\}$ is bounded. By the Bolzano-Weierstrass theorem, $\{K_i\}$ has a limit point, say K^* . By Lemma 7, S_0 is closed, so that $K^* \in S$.

An optimal solution which necessarily stabilizes the closed-loop system is seen to exist for the large class of problems which meet the conditions required by Theorem 2. It is of interest to note that these conditions include the cases of no measurement noise ($\hat{V} = 0$), and no control penalty ($R = 0$) as well as $\hat{V} = R = 0$ simultaneously. Furthermore, no restrictions are placed on the relative magnitude of the number of states, n , the number of measurements, m , and the number of controls, r ; the ranks of Γ and C are also arbitrary. Thus, multiple measurements of the same variable (i.e., C does not have full rank) or cases where there are more controls than measurements (or states) will have an optimal stable solution if the existence conditions are met. Then, the optimal gain may be obtained using the algorithm presented.

Theorem 3

Let Q and \hat{W} be positive definite, Γ and C have full rank, and $m \leq n$, $r \leq n$. Then $J(K)$ has a finite minimum over \mathcal{D} if, and only if, (ϕ, Γ, C) is output stabilizable. The minimal gain stabilizes the system.

Proof: Suppose (ϕ, Γ, C) is not output stabilizable, $K \in R^{rm}$. Then let³ $x \in C^n$ be a normalized eigenvector of $\phi(K)$ corresponding to an eigenvalue λ , such that $|\lambda| > 1$. From Lemma 1, Eq. (12), note that

$$x^H P_{i+1}(K) x \geq |\lambda|^2 x^H P_i(K) x + x^H Q x \quad 4 \quad (56)$$

³ C^n is the set of n -dimensional vectors with complex components.

⁴ H denotes the complex conjugate transpose.

$$x^H P_i(K) x \geq (i+1) x^H Q x > 0, \quad |\lambda| \geq 1 \quad (57)$$

where (57) is obtained by solving (56) and the fact that $Q > 0$. It follows that

$$\rho(P_i(K)) \geq x^H P_i(K) x \geq (i+1) x^H Q x \geq (i+1) m(Q), \quad (58)$$

where $m(Q) > 0$ is the smallest eigenvalue of Q ; so that using (11),

$$J_N(K) \geq \frac{1}{2} \frac{1}{N+1} \sum_{i=0}^N \text{tr} \{ P_i(K) \hat{W} \} \geq \frac{M(Q) m(\hat{W})}{2(N+1)} \sum_{i=0}^N (i+1) \uparrow \infty. \quad (59)$$

Thus, $J(K)$ is not finite for any $K \in R^{rm}$, which shows necessity. For sufficiency, first note that we have also shown that $S = \mathcal{D}$, since whenever $\rho(\phi(K)) \geq 1$ the limit in (10) exists but is not finite; i.e., $\mathcal{D} \subset S$. Thus, if (ϕ, Γ, C) is output stabilizable

$$J^* = \inf_{K \in \mathcal{D}} J(K) = \inf_{K \in S} J(K) < \infty. \quad (60)$$

Note that $\Gamma' Q \Gamma > 0$, and $C \hat{W} C' > 0$. Now since $Q > 0$, if $0 < \varepsilon_1 \leq m(Q)/\rho(C'C)$

$$\varepsilon_1 x' C'C x \leq \frac{m(Q)}{\rho(C'C)} \rho(C'C) x'x \leq m(Q) x'x \leq x' Q x, \quad x \in R^n. \quad (61)$$

Similarly, if $0 < \varepsilon_2 \leq m(\hat{W})/\rho(\Gamma\Gamma')$, then

$$\varepsilon_2 \Gamma\Gamma' \leq m(\hat{W}) I \leq \hat{W}. \quad (62)$$

Letting $\varepsilon = \min(\varepsilon_1, \varepsilon_2)$, it can be seen that all the conditions of Theorem 2 are met, so that a minimum in S exists.

Theorem 2 and Theorem 3 show that measurement noise or control penalty terms are not necessary for a solution to exist, which is a major difference between the discrete and continuous output feedback problems. For the

continuous deterministic as well as stochastic problems, a solution does not exist when the control penalty term vanishes; i.e., $R = 0$, as can be easily verified by considering a first order example. Furthermore, note that output stabilizability is not a necessary condition for the existence of a solution in discrete or continuous problems when Q is not positive definite. This can be verified by the trivial counterexample of an unstabilizable system with $Q = 0$ and $R > 0$, which has a minimum at $K = 0$, $J(0) = 0 < \infty$. Non-trivial counterexamples, where $Q \neq 0$ but singular, can be easily constructed for systems of order greater than 1. Finally, while the existence conditions given are not necessary and can be further generalized, they cover a broad class of systems and are simple for verification purposes.

Whereas the question of existence has been satisfactorily treated, and the development of a reliable algorithm will be treated in Section V, "significant" results on the uniqueness of the optimal solution are not available, and require further attention.

The existence conditions obtained are summarized below for ease of reference.

E-1. (C, ϕ, Γ) is output stabilizable, $(\Gamma' Q \Gamma + R) > 0$, $(C \hat{W} C' + \hat{V}) > 0$,
 $Q \geq \epsilon C' C$ and $\hat{W} \geq \epsilon \Gamma \Gamma'$, $\epsilon > 0$.

E-2. (C, ϕ, Γ) is output stabilizable, $Q > 0$, $\hat{W} > 0$, Γ and C have full rank,
 $m \leq n$, $r \leq n$

If one of the above conditions holds, a stable global minimum exists. It should be noted that the class of problems covered by E-2 is a subset of the class covered by E-1.

IV. INCREMENTAL COST AND NECESSARY CONDITIONS

The necessary conditions for the optimal discrete/continuous, stochastic/deterministic output feedback problems have been previously explored [1] - [13]. These conditions have usually been obtained using the Langrangian approach which requires the differentiability of the cost function. As the resulting equations are coupled nonlinear matrix equations, a reliable method of obtaining their solution has not been available despite numerous efforts.

The approach taken here is not to solve the necessary conditions, but to obtain a gain which minimizes the cost function. The necessary conditions are not required (directly) for the development of the algorithm, but are a by-product of the development. The optimal gain, however, is a solution of the necessary conditions. Thus, the approach taken is to obtain an expression for the incremental cost; i.e., the change in the cost function due to a change in the gain. The following important lemma provides the desired expression.

Lemma 9

Let K and $K + \Delta K$ be in S ; then the incremental cost is given by

$$\Delta J(K, \Delta K) = J(K + \Delta K) - J(K) \quad (63)$$

$$\begin{aligned} &= \frac{1}{2} \text{tr} \left\{ 2\Delta K' \left[\hat{P}(K + \Delta K) K \hat{S}(K) - \Gamma' P(K + \Delta K) \phi S(K) C' \right] \right. \\ &\quad \left. + \Delta K' \hat{P}(K + \Delta K) \Delta K \hat{S}(K) \right\} \quad (64) \end{aligned}$$

where

$$\hat{P}(K) = \Gamma' P(K) \Gamma + R, \quad \hat{S}(K) = C S(K) C' + \hat{V}. \quad (65)$$

Proof: Let K and $K + \Delta K$ be in S . Substituting (14) into (63), we obtain

$$\begin{aligned} \Delta J(K, \Delta K) = & \frac{1}{2} \text{tr} \{ \Delta P(K, \Delta K) \hat{W} \} + \frac{1}{2} \text{tr} \{ 2\Delta K' \hat{P}(K + \Delta K) K \hat{V} \\ & + \Delta K' \Gamma' \Delta P(K, \Delta K) \Gamma K \hat{V} + \Delta K' \hat{P}(K + \Delta K) \Delta K \hat{V} \} \end{aligned} \quad (66)$$

Substituting the infinite series solution of (21) into (66) and using trace identities, it can be shown that

$$\begin{aligned} \Delta J(K, \Delta K) = & \frac{1}{2} \text{tr} \left\{ 2\Delta K' \left[\hat{P}(K + \Delta K) K \hat{V} + (R K C - \Gamma' P(K + \Delta K) \phi(K)) S(K) C' \right] \right. \\ & \left. + \Delta K' \hat{P}(K + \Delta K) \Delta K \hat{S}(K) \right\} \end{aligned} \quad (67)$$

Rearranging the linear terms results in (64).

The usefulness of Lemma 9 is largely due to its generality. Note that the incremental cost function $\Delta J(K, \Delta K)$ is the total change in $J(K)$, not the first order variation. Also note that the only restriction placed is that K and $K + \Delta K$ belong to the stability set S . This condition ensures that ambiguous terms of the form $\infty - \infty$ do not appear in the proof. This generality makes Lemma 9 useful in dynamic compensation and decentralized control problems as well as the output feedback problem considered here. An immediate consequence is given in the following Lemma.

Lemma 10

$J(K)$ is continuously differentiable on S , and

$$\frac{\partial J}{\partial K}(K) = \hat{P}(K) K \hat{S}(K) - \Gamma' P(K) \phi S(K) C', \quad K \in S \quad (68)$$

Proof: From Lemma 3, recall that $P(K)$, hence $\hat{P}(K)$, is continuous on S . By observation of (64) and the definition of differentiation, we obtain (68) which, by Lemma 3, is continuous.

It may be noted that the gradient itself is differentiable on S , and that, in fact, $J(K)$ has derivatives of all orders on S . Since $J(K)$ is continuously differentiable on S , if a minimum in S exists, then the gradient must vanish; hence,

$$(\Gamma' P(K^*) \Gamma + R) K^* (C S(K^*) C' + \hat{V}) = \Gamma' P(K^*) \phi S(K^*) C', K^* \in S, \quad (69)$$

where $P(K^*)$ and $S(K^*)$ satisfy (15) and (46 b), resp. Thus, (69), (46 b) and (15) are the necessary conditions. It is clear that when E-1 or E-2 hold, the necessary conditions have at least one solution, $K^* \in S$.

V. DEVELOPMENT OF THE ALGORITHM

While the necessary conditions for the various formulations of the output feedback problem (e.g., continuous and stochastic, discrete and deterministic, etc.) are well-known, the unavailability of a reliable algorithm to determine its solutions has been the major hindrance to the successful application of optimal output feedback and dynamic compensation to design problems of practical significance. The algorithm developed in this section is shown to provide a systematic method of obtaining a solution to the necessary conditions for the class of problems which satisfy one of the existence conditions. Furthermore, the authors' experience with non-trivial systems indicates a "fast" rate of convergence, as is discussed in the next section. The following theorem provides the basis for the algorithm.

Theorem 4 (Convergence)

Let one of the existence conditions E-1 or E-2 hold, and let K_0 be in S . Then there exist $\beta \in (0, 1]$ and K^* in S such that

$$J(K_i) \downarrow J(K^*), \text{ and } \frac{\partial J}{\partial K}(K_i) \rightarrow \frac{\partial J}{\partial K}(K^*) = 0, \quad (70)$$

whenever $0 < \alpha \leq \beta$ and the sequence $\{K_i, i \geq 0\}$ is defined by

$$K_{i+1} = K_i + \alpha d(K_i), \quad i \geq 0 \quad (71)$$

$$d(K_i) = \hat{P}(K_i)^{-1} \Gamma' P(K_i) \phi S(K_i) C' \hat{S}(K_i)^{-1} - K_i, \quad K_i \in S \quad (72)$$

Proof: Consider the inverse image

$$S_0 = J^{-1}\left(\left[0, J(K_0)\right]\right) = \left\{K \in S \mid 0 \leq J(K) \leq J(K_0)\right\} \quad (73)$$

By Lemma 7 (also note (61) and (62)), S_0 is closed. Recall that if E-1 or E-2 holds, then S_0 is also bounded, by Lemma 8. Now, to show that for some $a > 0$, the set

$$S_{0a} = \left\{K + \alpha d(K) \in R^{rm} \mid K \in S_0, \alpha \in [0, a]\right\} \quad (74)$$

is a subset of S , suppose that no such $a > 0$ exists. Then it is possible to construct a sequence $a_i \downarrow 0$ and a sequence $\{K_i\} \subset S_0$ such that

$$\rho(\phi(K_i + a_i d(K_i))) \geq 1. \quad (75)$$

Since S_0 is closed and bounded, by the Bolzano-Weierstrass theorem $\{K_i\}$ has a limit point, say \bar{K} in S_0 . Now note that if E-1 or E-2 holds, then

$$\hat{P}(K) \geq \Gamma' Q \Gamma + R > 0, \quad K \in S \quad (76)$$

$$\hat{S}(K) \geq C \hat{W} C' + \hat{V} > 0, \quad K \in S \quad (77)$$

It follows that $\hat{P}(K)^{-1}$ and $\hat{S}(K)^{-1}$, and hence $d(K)$, exist and are continuous on S ; so that $d(K)$ is continuous and bounded on the closed and bounded set S_o . Since $\rho(\phi(K))$ is also continuous, for some subsequence

$$\begin{aligned} K_{i_j} + a_{i_j} d(K_{i_j}) &\rightarrow \bar{K}, \\ \rho(\phi(K_{i_j}) + a_{i_j} d(K_{i_j})) &\rightarrow \rho(\phi(\bar{K})) \geq 1, \end{aligned} \quad (78)$$

which is a contradiction since \bar{K} belongs to S_o . It follows that $S_{oa} \subset S$ for some $a > 0$, which will now be considered fixed.

From its construction (see (74)) and the continuity of $d(K)$, it can be shown that S_{oa} is closed and bounded. Since $P(K)$ is continuously differentiable over the closed and bounded set S_{oa} , it can be shown that for some $M < \infty$

$$\| \Delta P(K, \alpha d(K)) \| \leq \alpha M \| d(K) \|, \quad K \in S_o, \alpha \in [0, a]. \quad (79)$$

Rearranging the expression for the cost increments given in Lemma 9, we obtain

$$\begin{aligned} \Delta J(K, \Delta K) = \frac{1}{2} \text{tr} \left\{ 2\Delta K' \frac{\partial J}{\partial K}(K) + \Delta K' \hat{P}(K) \Delta K \hat{S}(K) \right. \\ \left. + 2\Delta K' \Gamma' \Delta P(K, \Delta K) \left[\Gamma(K + \Delta K) \hat{S}(K) - \phi S(K) C' \right] \right\} \\ K, K + \Delta K \in S \end{aligned} \quad (80)$$

Using Lemma 10 in (72)

$$d(K) = - \hat{P}(K)^{-1} \frac{\partial J}{\partial K}(K) \hat{S}(K)^{-1}, \quad K \in S_o \quad (81)$$

Now set $\Delta K = \alpha d(K)$ in (80). As shown above, $K + \alpha d(K)$ belongs to $S_{oa} \subset S$ whenever K is in S_o , so that (80) can be rearranged in the form

$$\Delta J(K, \alpha d(K)) = \frac{1}{2} \left[-\alpha(2 - \alpha) A(K) + \alpha^2 B(K, \alpha) \right],$$

$$K \in S_0, \quad \alpha \in (0, a], \quad (82)$$

where

$$A(K) = \text{tr} \left\{ \hat{S}(K)^{-1} \frac{\partial J}{\partial K}(K), \hat{P}(K)^{-1} \frac{\partial J}{\partial K}(K) \right\} \quad (83)$$

$$= \text{tr} \left\{ d(K)' \hat{P}(K) d(K) \hat{S}(K) \right\} \geq 0 \quad (84)$$

$$B(K, \alpha) = \frac{2}{\alpha} \text{tr} \left\{ d(K)' \Gamma' \Delta P(K, \alpha d(K)) \right. \\ \left. \left[\Gamma(K + \alpha d(K)) \hat{S}(K) - \phi S(K) C' \right] \right\} \quad (85)$$

Using (76), (77), (81) and (84) it can be shown that for some $M_2 > 0$

$$A(K) \geq M_2 \|d(K)\|^2 \geq 0, \quad K \in S_0. \quad (86)$$

On the other hand, using (79) and (85)

$$|B(K, \alpha)| \leq M_1 \|d(K)\|^2, \quad K \in S_0, \quad 0 \leq \alpha \leq a \quad (87)$$

for some $M_1 < \infty$. It follows that

$$|B(K, \alpha)| \leq \frac{M_1}{M_2} A(K) = M_3 A(K), \quad K \in S_0, \quad 0 \leq \alpha \leq a. \quad (88)$$

Select β in $(0, 1]$ such that $\beta \leq a$ and $\beta \leq 1/M_3$, and let α satisfy $0 < \alpha \leq \beta$. Now substitute (88) into (82)

$$\Delta J(K, \alpha d(K)) \leq \frac{1}{2} \left[-\alpha A(K) + \alpha^2 M_3 A(K) \right] \\ = \frac{1}{2} \left[-\alpha(1 - \alpha M_3) A(K) \right], \quad K \in S_0, \quad 0 < \alpha \leq \beta \quad (89)$$

Since $A(K) > 0$ whenever $\frac{\partial J}{\partial K}(K) \neq 0$, and $0 < \alpha < 1/M_3$,

$$\Delta J(K, \alpha d(K)) \leq 0, \quad K \in S_0, \quad 0 < \alpha \leq \beta \quad (90)$$

with equality if, and only if, $\frac{\partial J}{\partial K}(K) = 0$.

Hence, $K + \alpha d(K)$ belongs to S_o , so that $S_{o\beta} \subset S_o$. In particular, S_o is invariant under the function

$$f(K) = K + \alpha d(K), \quad 0 < \alpha \leq \beta \quad (91)$$

i.e., if $K \in S_o$ then $f(K) \in S_o$. It follows that the sequence $\{K_i\}$ defined by (71) is a subset of S_o , and $J(K_i)$ is monotonic and bounded, and necessarily converges, while $\{K_i\}$ has a limit point, K^* , in S_o ; hence,

$$0 \leq J(K_i) \downarrow J(K^*). \quad (92)$$

The increments $\Delta J(K_i, \alpha d(K_i))$ must then converge to zero. Combining (86) and (89),

$$0 \leq M_2 \|d(K_i)\|^2 \leq A(K_i) \leq \frac{-1}{\alpha(1 - \alpha M_3)} \Delta J(K_i, \alpha d(K_i)) \rightarrow 0 \quad (93)$$

so that $A(K_i)$ and $d(K_i)$ vanish. From (81) $\frac{\partial J}{\partial K}(K_i) \rightarrow 0$; since any subsequence also converges to zero and the gradient is continuous (Lemma 10) $\frac{\partial J}{\partial K}(K^*) = 0$, which completes the proof.

It is seen that for a broad class of problems, it is possible to construct a sequence of gains whose costs monotonically decrease, while the corresponding gradients converge to zero, if any stabilizing gain is available. It is guaranteed that the sequence of gains has a limit point, K^* , which stabilizes the closed loop system and satisfies the necessary condition; i.e., K^* is a critical point of $J(K)$. Thus, it is possible to find a stabilizing gain whose gradient is as small as desired. Furthermore, any stabilizing gain can be used to start the algorithm. An initialization procedure is discussed in [26].

An important aspect of the method is due to the invariance of the set

S_0 under $f(K)$ given in (91). This property insures that the new (successor) gain will not fall outside the stability region. It is also significant that a constant value of the parameter α (appropriately selected) is sufficient to obtain the convergence properties needed. This property makes it unnecessary to conduct lengthy line searches at every iteration. Finally, it is the exploitation of the specific form of the cost function, and, in particular, the "almost quadratic" form of the incremental cost that suggests the use of the direction $d(K)$. This special form of the cost increments makes it unnecessary to compute or approximate large order ($m \times m$) Hessian matrices which are often used in gradient search methods.

Theorem 4 suggests the following algorithm. The objective is to choose a large positive $\alpha \leq 1$ in (91) which makes the algorithm stable. The initial α chosen by the designer may be too large. Steps 4 and 7 check for lack of convergence and Step 8 decreases α using z . Theorem 4 guarantees that only a finite number of decreases in α will be required to arrive at a value of α for which the algorithm is stable. The equations in Step 2 and Step 3 can be solved using the Bartels-Stewart algorithm available in control software packages such as ORACLS, [27].

Algorithm

Step 1 Choose K_0 so that $\phi(K_0) = \phi - \Gamma K_0 C$ is stable, $\alpha_0 \in (0, 1]$, $z > 1$, and set $i = 0$.

Step 2 Solve the following equation for $S(K_i)$

$$S(K_i) = \phi(K_i) S(K_i) \phi(K_i)' + \Gamma K_i \hat{V} K_i' \Gamma' + \hat{W}$$

Step 3 Solve the following equation for $P(K_i)$

$$P(K_i) = \phi(K_i)' P(K_i) \phi(K_i) + C' K_i' R K_i C + Q$$

Step 4 Compute $\hat{P}(K_i)$, $\hat{S}(K_i)$

$$\hat{P}(K_i) = \Gamma' P(K_i) \Gamma + R$$

$$\hat{S}(K_i) = C S(K_i) C' + \hat{V}$$

Invert $\hat{P}(K_i)$ and $\hat{S}(K_i)$ using Cholesky decomposition. If either of these symmetric matrices is not positive definite, go to Step 8.

Step 5 Compute K_{new} , $d(K_i)$

$$K_{\text{new}} = \hat{P}(K_i)^{-1} \Gamma' P(K_i) \phi S(K_i) C' \hat{S}(K_i)^{-1}$$

$$d(K_i) = K_{\text{new}} - K_i$$

Step 6 Compute K_{i+1}

$$K_{i+1} = K_i + \alpha_i d(K_i)$$

Step 7 Evaluate Cost function

$$J(K_i) = \frac{1}{2} \text{tr} \{ P(K_i) \hat{W} \} + \frac{1}{2} \text{tr} \{ K_i' (\Gamma' P(K_i) \phi + R) K_i \hat{V} \}$$

If $i = 0$ set i to 1, $\alpha_{i+1} = \alpha_i$, and go to Step 2

Check to see if the algorithm is stable for the selected α :

If $J(K_i)$ is negative go to Step 8

If any element along the diagonal of $S(K_i)$ or $P(K_i)$ is negative
go to Step 8

If $J(K_i) - J(K_{i-1})$ is negative go to Step 9, otherwise go to Step 8

Step 8 Decrease α

$$\alpha_i = \alpha_i / z$$

Go back to previous stabilizing gain

$$K_i = K_{i-1}, \quad d(K_i) = d(K_{i-1})$$

$$\text{Compute } K_{i+1}: \quad K_{i+1} = K_i + \alpha_i d(K_i)$$

Set $\alpha_{i+1} = \alpha_i$, $i = i+1$ and go to Step 2

Step 9 Compute $\frac{\partial J}{\partial K}(K_i)$

$$\frac{\partial J}{\partial K}(K_i) = \hat{P}(K_i) K_i \hat{S}(K_i) - \Gamma' P(K_i) \phi S(K_i) C'$$

$$\text{IF } \left\| \frac{\partial J}{\partial K}(K_i) \right\| \text{ and } J(K_i) - J(K_{i-1})$$

are less than some convergence criterion

STOP otherwise set $\alpha_{i+1} = \alpha_i$, $i = i+1$ and go to Step 2

VI. APPLICATION TO AN AIRCRAFT OUTER-LOOP DIGITAL CONTROL DESIGN PROBLEM

The output feedback control system design methodology in the previous section is currently being used to design an outer-loop control system for a typical small transport jet aircraft. The purpose of the outer-loop system is to feedback guidance errors to the inner-loop control system so that the aircraft tracks a 3-dimensional flight path. Initial results from the outer-loop synthesis are presented to illustrate properties of the output feedback algorithm and to compare the algorithm to other numerical approaches.

The example given here is the design of the horizontal path following outer-loop feedback gains for a proposed set of lateral-direction guidance error signals. The lateral digital inner-loop control system has previously been designed and extensively flight tested. The lateral, inner-loop control system feeds back filtered roll rate, \hat{p} , and roll angle, ϕ , to the aileron/

spoiler command, δ_{AC} , and feeds back washed-out filtered yaw rate, r_{wo} , to the rudder command, δ_{RC} . A block diagram of the continuous time inner-loop control system before the Tustin transformation is used to obtain the digital implementation is shown in Figure 1.

The continuous-time linear model of the aircraft with the closed inner-loop system has the eigenvalues shown in Table 1. The aircraft model is determined with the aircraft trimmed on a three degree glideslope at 64 m/s. The model includes six aircraft states (Δv , Δr , Δp , $\Delta \phi$, $\Delta \psi$, Δy), two gust states (Δw_1 , Δw_2), four inner-loop filter states ($\Delta \hat{p}$, $\Delta \hat{\phi}_c$, $\Delta \hat{r}$, Δr_{wo}), and the aileron actuator state ($\Delta \delta_a$) for a total of thirteen states. The controls are roll angle command, $\Delta \phi_c$, and rudder command $\Delta \delta_{rc}$. The gust terms are modelled using the well-known Dryden spectrum. The white noise in the gust model and in the model of the inner-loop measurements are used to determine some of the elements in the continuous-time process noise covariance matrix, W . All of the elements along the W diagonal are shown in Table 2. The discrete time process noise covariance matrix \hat{W} is determined from the matrix, W , and the plant dynamics represented at the sampling instants [25].

A set of horizontal path guidance errors signals being investigated uses yaw angle error, $\Delta \psi$, lateral position error Δy , and lateral velocity error for feedback. These error signals determine the elements in the observation matrix, C , the quadratic weighting elements in Q , and the observation noise matrix, V . Values for the continuous time diagonal weighting elements in Q and R are shown in Table 2. After these elements are specified, the continuous-time problem is transformed to an equivalent discrete-time problem using the sampled-data regulator [25].

Three algorithms are used for comparison purposes to solve the output feedback problem just presented. Algorithm I is the discrete version of the

numerical approach presented in [5] and discussed as Algorithm 2 in [20] and [21]. Algorithm I is explicitly discussed in [13]. Algorithm I is actually a special case of the algorithm in Section V where the latter is constrained to use $\alpha = 1.0$. The continuous time version of the algorithm is known to be divergent for specific examples [20]. Algorithm II is the discrete version of the Davidon Fletcher Powell algorithm (discussed in [14], [19], and called Algorithm 4 in [21]), where the Hessian is restarted every N steps with a positive definite priming matrix. Algorithm III is the one presented in Section V. The starting stabilizing feedback gain for all three algorithms is obtained using an output feedback pole placement procedure discussed in [26].

Table 3 compares the three algorithms for two starting values of the stabilizing output feedback gain, K_o . Test 1 uses K_o "far" from the optimal gain. In both tests Algorithm I diverges. Algorithm II converges slowly and was prematurely terminated in Test 1 because of the excessive computations needed to reach a minimum. Algorithm III was started far from the optimal gain with $\alpha_o = 1.0$. Stability of the algorithm was obtained when α_i was eventually reduced to 0.75 in Step 7. The algorithm converged in 44 iterations in Test 1 to an optimal gain using a convergence criterion of 10^{-4} . Algorithm III performed considerably better than Algorithms I and II when K_o is far from the optimal gain in Test 1. Algorithm II is known to have better performance if the starting point is close to the minimum value. As shown in Test 2, however, Algorithm III still performs better than the gradient based approach of Algorithm II for K_o chosen close to the optimum gain. Algorithm III reduced α to 0.75 and reached a minimum using 12 iterations requiring approximately a quarter of the amount of computation time needed by Algorithm II to reach a minimum.

The effect of varying the noise covariance matrices is shown in Table 1. If only the measurement noise is changed the effect is to decrease the feedback gains on noisy measurements while increasing the feedback gains on measurements with reduced noise. If the large terms in W in Table 2 are removed, the result is shown in the last row in Table 1. The gains are reduced considerably. The best average long term stochastic performance for a plant with low process noise is to use little control activity. Non-zero initial conditions, however, may require a long time to asymptotically return to zero but ultimately contribute nothing to the infinite-time averaged stochastic cost function. The conflict between short term desirable transient response and long term stochastic performance will be addressed in greater detail in future efforts.

VII. CONCLUSIONS

The problem of designing an optimal instantaneous output feedback controller for a stochastic discrete-time system has been considered. Two sets of sufficient conditions for the existence of a minimum of the cost function are derived (E-1, E-2). The optimal controller is realized by a feedback gain matrix which is the simultaneous solution of three coupled matrix equations ((15), (46 b), (69)). A computational algorithm to obtain an optimal gain is presented. If (81) is substituted into (71) the algorithm can be interpreted as a cross between sequential methods and gradient search methods for determining the output feedback gain which minimizes the cost function. The algorithm produces a sequence of gains which monotonically decreases the cost function using a special direction obtained by a transformation of the cost gradient. A line search is avoided by showing that there is a fixed constant positive scalar in (71) which guarantees the sequence of gains has a limit point satisfying the necessary conditions for

optimality. A non-trivial 13th order aircraft digital control design example is used to show that the algorithm converges faster and more reliably than a sequential and gradient search method for determining the optimal output feedback gain.

REFERENCES

1. Axsator, S., "Sub-Optimal Time Variable Feedback Control of Linear Dynamic Systems with Random Inputs," International Journal of Control, Vol. 4, No. 6, 1966, pp. 549-566.
2. Rekasius, Z. V., "Optimal Linear Regulators with Incomplete State Feedback," IEEE Trans. Automatic Control, Vol. AC-12, June 1967, pp. 296-299.
3. Kosut, R. L., "Suboptimal Control of Linear Time-Invariant Systems Subject to Control Structure Constraints," IEEE Trans. Automatic Control, Vol. AC-15, October 1970, pp. 557-563.
4. Levine, W. S., and Athans, M., "On the Determination of the Optimal Constant Output Feedback Gains for Linear Multivariable Systems", IEEE Trans. Automatic Control, Vol. AC-15, February 1970, pp. 44-48.
5. Anderson, B. D. O., and Moore, J. B., Linear Optimal Control, Prentice Hall, Englewood Cliffs, New Jersey, 1971.
6. Johnson, T. L., and Athans, M., "On the Design of Optimal Constrained Dynamic Compensators for Linear Constant Systems," IEEE Trans. Automatic Control, Vol. AC-15, December 1970, pp. 658-660.
7. Basuthakur, S., and Knapp, C. H., "Optimal Constant Controllers for Stochastic Linear Systems," IEEE Trans. Automatic Control, Vol. AC-20, October 1975, pp. 664-666.
8. Mendel, J. M., and Feather, J., "On the Design of Optimal Time-Invariant Compensators for Linear Stochastic Time-Invariant Systems," IEEE Trans. Automatic Control, Vol. 20, No. 5, October 1975, pp. 653-656.
9. Wenk, C. J., and Knapp, C. H., "Parameter Optimization in Linear Systems with Arbitrarily Constrained Controller Structure," IEEE Trans. Automatic Control, Vol. AC-25, June 1980, pp. 496-500.

10. Ermer, C. M., and Vandelinde, V. D., "Output Feedback Gains for a Linear-Discrete Stochastic Control Problem," IEEE Trans. Automatic Control, Vol. AC-18, April 1973, pp. 154-157.
11. Kurtaran, B., and Sidar, M., "Optimal Instantaneous Output-Feedback Controllers for Linear Stochastic Systems," International Journal of Control, Vol. 19, 1974, pp. 797-816.
12. Joshi, S. W., "Design of Optimal Partial State Feedback Controllers for Linear Systems in Stochastic Environments," Proc. of 1975 IEEE Southwest Conference, Charlotte, North Carolina, 1975.
13. O'Reilly, J., "Optimal Instantaneous Output-Feedback Controllers for Discrete-Time Systems with Inaccessible States," International Journal of System Science, Vol. 9, 1978, pp. 9-16.
14. Choi, S. S., and Sirisena, H. R., "Computation of Optimal Output Feedback Gains for Linear Multivariable System," IEEE Trans. Automatic Control, Vol. AC-19, June 1974, pp. 257-258.
15. Sobel, K., and Kaufman, H., "Application of Stochastic Optimal Reduced State Feedback Gain Computation Procedures to the Design of Aircraft Gust Alleviation Controllers," Proc. of 1978 IFAC Conference, Helsinki, Finland, 1978.
16. Bingulac, S. P., Cuk, N. M., and Calvouic, M. S., "Calculation of Optimal Feedback Gains for Output-Constrained Regulators," IEEE Trans. Automatic Control, Vol. AC-20, February 1975, pp. 164-166.
17. Choi, S. S., and Sirisena, H. R., "Computation of Optimal Output Feedback Controls for Unstable Linear Multivariable Systems," IEEE Trans. Automatic Control, Vol. AC-22, February 1977, pp. 134-136.
18. Horisberger, H. P., and Belanger, P. R., "Solution of the Optimal Constant Output Feedback Problem by Conjugate Gradients," IEEE Trans. Automatic Control, Vol. AC-19, 1974, pp. 434-435.

19. Knox, J. R., and McCarty, J. M., "Algorithms for Computation of Optimal Constrained Output Feedback for Linear Multivariable Flight Control Systems," Paper No. 78-1290, Proc. of 1978 AIAA Conference, Palo Alto, California, August 1978.
20. Söderström, T., "On Some Algorithms for Design of Optimal Constrained Regulators," IEEE Trans. Automatic Control, Vol. AC-23, December 1978, pp. 1100-1101.
21. Srinivasa, Y. G., and Rajogopalan, T., "Algorithms for the Computation of Optimal Output Feedback Gains," Proc. of 18th IEEE Conference on Decision and Control, Fort Lauderdale, Florida, December 1979.
22. Athans, M., "The Role and Use of the Stochastic Linear-Quadratic-Gaussian Problem in Control System Design," IEEE Trans. Automatic Control, Vol. AC-16, December 1971, pp. 529-552.
23. Bower, J. L., and Schultheiss, P. M., Introduction to the Design of Servomechanisms, John Wiley & Sons, Inc., New York, 1958.
24. Halyo, N., and Foulkes, R. E., "On the Quadratic Sampled-Data Regulator with Unstable Random Disturbances," Proc. of the International Conference on Systems, Man, and Cybernetics, October 1974, pp. 99-103.
25. Halyo, N., and Caglayan, A. K., "A Separation Theorem for the Stochastic Sampled-Data LQG Problem," International Journal of Control, Vol. 23, No. 2, February 1976, pp. 237-244.
26. Broussard, J. R., "Output Feedback Implicit Model Following," Proc. of 20th IEEE Conference on Decision and Control, San Diego, California, December 1981.
27. Armstrong, E. S., ORACLS - A Design System for Linear Multivariable Control, Marcel-Dekher, Inc., New York, 1980.

APPENDIX PROOF OF THEOREM 1

This appendix contains a detailed proof of Theorem 1 which was used in obtaining existence conditions for the optimal output feedback problem. This property of output stabilizable systems states that the stability of the closed-loop system is completely determined by the convergence of $C \phi(K)^n \Gamma$ to zero. This property is used to show that $S(a)$ is a closed set under the conditions given in Lemmas 6 or 7. The proof of Theorem 1 is relatively straightforward when the eigenvalues of $\phi(K)$ are distinct. The general case of Theorem 1 allows $\phi(K)$ to have multiple eigenvalues. The general case of Theorem 1, which is necessary to obtain the results in the report requires a more detailed and lengthy derivation and is presented in the remainder of this appendix. The following Lemmas are used in the proof of Theorem 1.

Lemma A1

Let (C, ϕ, Γ) be output stabilizable. Then for any $K \in R^{rm}$

$$\phi(K) x = \lambda x, \text{ and } x^H C^H C x = 0 \rightarrow |\lambda| < 1, \text{ and} \quad (A1)$$

$$\phi^H(K) z = \lambda z, \text{ and } z^H \Gamma \Gamma^H z = 0 \rightarrow |\lambda| < 1. \quad (A2)$$

Proof: First note that for any K , $(C, \phi(K), \Gamma)$ is output stabilizable.

Thus, it suffices to show (A1) and (A2) for $K = 0$. Now suppose

$$\phi x = \lambda x, \quad C x = 0, \quad \text{and} \quad |\lambda| \geq 1. \quad (A3)$$

Then,

$$(\phi - \Gamma K C)x = \phi x - \Gamma K C x = \lambda x, \quad |\lambda| \geq 1, \quad \forall K. \quad (A4)$$

It follows that (C, ϕ, Γ) cannot be output stabilizable, a contradiction.

Similarly, if

$$\phi^H z = \lambda z, \quad \phi^H z = 0, \quad \text{and} \quad |\lambda| \geq 1, \quad (\text{A5})$$

then

$$(\phi - \Gamma K C)^H z = \phi^H z - C^H K^H \Gamma^H z = z, \quad |\lambda| \geq 1, \quad \forall K. \quad (\text{A6})$$

Thus (C, ϕ, Γ) is not output stabilizable, a contradiction.

Lemma A2

Let λ be an eigenvalue of ϕ such that

$$\phi x_i = \lambda x_i + x_{i+1}, \quad 1 \leq i \leq p, \quad x_{p+1} = 0. \quad (\text{A7})$$

Then

$$\phi^n x_i = \sum_{k=0}^{p-1} b_{kn} \lambda^{n-k} x_{i+k}, \quad 1 \leq i \leq p, \quad n \geq 0, \quad (\text{A8})$$

$$b_{k \ n+1} = b_{kn} + b_{k-1 \ n}, \quad b_{ko} = \delta_{ko}, \quad b_{-1 \ n} = 0, \quad b_{0n} = 1;$$

$$b_{kn} = 0, \quad k > n. \quad (\text{A9})$$

Proof: First note that (A8) holds for $n = 0$ and $n = 1$. Now assume that

(A8) holds for an arbitrary n ; then

$$\phi^{n+1} x_i = \phi \sum_{k=0}^{p-1} b_{kn} \lambda^{n-k} x_{i+k} = \sum_{k=0}^{p-1} b_{kn} \lambda^{n-k} (\lambda x_{i+k} + x_{i+k+1}) \quad (\text{A10})$$

$$= \sum_{k=0}^{p-1} b_{kn} \lambda^{n+1-k} x_{i+k} + \sum_{k'=1}^{p-1} b_{k'-1 \ n} \lambda^{n-k'+1} x_{i+k'}, \quad (\text{A11})$$

$$= \sum_{k=0}^{p-1} b_{kn} \lambda^{n+1-k} x_{i+k} + \sum_{k'=0}^{p-1} b_{k'-1 \ n} \lambda^{n+1-k'} x_{i+k'}, \quad (\text{A12})$$

$$= \sum_{k=0}^{p-1} (b_{kn} + b_{k-1 \ n}) \lambda^{n+1-k} x_{i+k}, \quad (\text{A13})$$

so that (A8) holds for $n+1$.

Note that the b_{kn} 's are the binomial coefficients, x_p is an eigenvector and x_i is a principle vector when $i = 1, 2, \dots, p$. Now let J be the Jordan canonical form of ϕ .

$$\phi = X J Z, \quad Z = X^{-1} \quad (A14)$$

where the columns of X are the principal vectors of ϕ . Partition J, X, Z as

$$J = \begin{pmatrix} J_1 & & 0 \\ & J_2 & \\ & & \ddots \\ 0 & & & J_L \end{pmatrix}, \quad X = (X_1 \ X_2 \ \dots \ X_L), \quad Z = \begin{pmatrix} Z_1 \\ Z_2 \\ \vdots \\ Z_L \end{pmatrix} \quad (A15)$$

$$X_\ell = (x_{\ell 1} \ x_{\ell 2} \ \dots \ x_{\ell p_\ell}), \quad z_\ell = \begin{pmatrix} z_{\ell 1} \\ z_{\ell 2} \\ \vdots \\ z_{\ell p_\ell} \end{pmatrix}, \quad J_\ell = \begin{pmatrix} \bar{\lambda}_\ell & 1 & 0 & \dots & 0 \\ 0 & \bar{\lambda}_\ell & 1 & \dots & 0 \\ \vdots & & & & \\ 0 & \dots & \dots & \dots & \bar{\lambda}_\ell \end{pmatrix} \quad (A16)$$

$1 \leq \ell \leq L$

$$\alpha_{li} = C x_{li}, \quad \beta_{li} = z_{li} \Gamma, \quad p = \max_{\ell} p_\ell, \quad (A17)$$

and define the unit step function Π as

$$\Pi_{ij} = \begin{cases} 1, & i \leq j \\ 0, & i > j \end{cases}$$

Lemma A3

$$C \phi^n \Gamma = \sum_{j=1}^J \sum_{k=0}^{p-1} B_{jk} b_{kn} \lambda_j^n, \quad (A18)$$

where b_{kn} is given by (A9), λ_j , $j = 1, 2, \dots, J$ are the distinct eigenvalues of ϕ , and

$$B_{jk} = \begin{cases} \ell_{j+1}^{-1} \\ \ell_{\sum=\ell_j} A_{\ell k} \lambda_j^{-k} \end{cases}, \quad \lambda_j \neq 0; \quad (A19)$$

$$\begin{cases} 0 \end{cases}, \quad \lambda_j = 0;$$

$$A_{\ell k} = \Pi_k p_{\ell-1} \prod_{i=1}^{p_{\ell}-k} \alpha_{\ell} \beta_{\ell i}, \quad \bar{\lambda}_{\ell} = \lambda_j = \bar{\lambda}_{\ell_j}, \quad \ell_j \leq \ell < \ell_{j+1} \quad (A20)$$

Proof:

$$C \phi^n \Gamma = \alpha Z \phi^n X \beta = \prod_{\ell=1}^L \alpha_{\ell} Z_{\ell} \phi^n \prod_{j=1}^L X_j \beta_j \quad (A21)$$

$$= \prod_{\ell=1}^L \alpha_{\ell} Z_{\ell} \phi^n X_{\ell} \beta_{\ell}, \quad (A22)$$

since

$$Z_{\ell} \phi^n X_j = Z_{\ell} X_j^n Z X_j = 0, \quad j \neq \ell. \quad (A23)$$

$$C \phi^n \Gamma = \prod_{\ell=1}^L \prod_{i=1}^{p_{\ell}} \prod_{j=1}^{p_{\ell}} \alpha_{\ell j} z_{\ell j} \phi^n x_{\ell i} \beta_{\ell i} \quad (A24)$$

Using Lemma A2,

$$C \phi^n \Gamma = \prod_{\ell=1}^L \prod_{i=1}^{p_{\ell}} \prod_{j=1}^{p_{\ell}} \alpha_{\ell j} z_{\ell j} \prod_{k=0}^{p_{\ell}-i} b_{kn} \bar{\lambda}_{\ell}^{n-k} x_{\ell i+1} \beta_{\ell i} \quad (A25)$$

$$= \prod_{\ell=1}^L \prod_{i=1}^{p_{\ell}} \prod_{k=0}^{p_{\ell}-i} b_{kn} \bar{\lambda}_{\ell}^{n-k} \left(\prod_{j=1}^{p_{\ell}} \alpha_{\ell j} z_{\ell j} x_{\ell i+1} \right) \beta_{\ell i} \quad (A26)$$

Noting that

$$z_{\ell j} x_{\ell i+1} = \delta_{j i+k}, \quad 1 \leq \ell \leq L, \quad (A27)$$

$$C \phi^n \Gamma = \prod_{\ell=1}^L \prod_{i=1}^{p_{\ell}} \prod_{k=0}^{p_{\ell}-i} \alpha_{\ell i+1} \beta_{\ell i} b_{kn} \bar{\lambda}_{\ell}^{n-k} \quad (A28)$$

$$= \prod_{\ell=1}^L \prod_{i=1}^{p_{\ell}} \prod_{k=0}^{p_{\ell}-i} \Pi_k p_{\ell-i} \alpha_{\ell i+1} \beta_{\ell i} b_{kn} \bar{\lambda}_{\ell}^{n-k} \quad (A29)$$

$$= \prod_{\ell=1}^L \prod_{k=0}^{p_{\ell}-1} \prod_{i=1}^{p_{\ell}-k} \Pi_k p_{\ell-i} \alpha_{\ell i+k} \beta_{\ell i} b_{kn} \bar{\lambda}_{\ell}^{n-k} \quad (\text{A30})$$

$$= \prod_{\ell=1}^L \prod_{k=0}^{p_{\ell}-1} \left(\prod_{i=1}^{p_{\ell}-k} \alpha_{\ell i+k} \beta_{\ell i} \right) b_{kn} \bar{\lambda}_{\ell}^{n-k} \quad (\text{A31})$$

$$= \prod_{\ell=1}^L \prod_{k=0}^{p_{\ell}-1} A_{\ell k} b_{kn} \bar{\lambda}_{\ell}^{n-k} \quad (\text{A32})$$

where

$$A_{\ell k} = \prod_{i=1}^{p_{\ell}-k} \alpha_{\ell i+1} \beta_{\ell i}, \quad p = \max_{1 \leq \ell \leq L} p_{\ell} \quad (\text{A33})$$

Now assume that the $\bar{\lambda}_{\ell}$'s have been ordered so that

$$\bar{\lambda}_{\ell} = \bar{\lambda}_{\ell_j} \triangleq \lambda_j, \quad \ell_j \leq \ell < \ell_{j+1}, \quad (\text{A34})$$

where $1 = \ell_1 < \ell_2 < \dots < \ell_J$, and the λ_j 's are distinct. Then (A32) can be rewritten as

$$C \phi^n \Gamma = \prod_{j=1}^J \prod_{k=0}^{p_{\ell_j}-1} \left(\prod_{\ell=\ell_j}^{\ell_{j+1}-1} A_{\ell k} \right) \lambda_j^{-k} b_{kn} \lambda_j^n, \quad (\text{A35})$$

which is the desired result.

Lemma A4

Let $C \phi^n \Gamma \rightarrow 0$. If $|\lambda_j| \geq 1$, then

$$B_{jk} = 0, \quad 0 \leq k \leq p-1, \quad (\text{A36})$$

where λ_j, B_{jk} are defined in Lemma A3.

Proof: First order the distinct eigenvalues λ_j of ϕ such that

$$\rho(\phi) = |\lambda_1| \geq |\lambda_2| \geq \dots \geq |\lambda_J| \quad (\text{A37})$$

Suppose that

$$|\lambda_j| \geq 1, j \leq J_1; \quad |\lambda_j| < 1, j > J_1 \quad (\text{A38})$$

Since b_{kn} is a polynomial in n of degree k ,

$$b_{kn} \lambda_j^n \rightarrow 0, \quad J \geq j > J_1, \quad 0 \leq k \leq p-1. \quad (\text{A39})$$

Hence, from the representation in Lemma A3, if $C \phi^n \Gamma \rightarrow 0$, then

$$\sum_{j=1}^{J_1} \sum_{k=0}^{p-1} B_{jk} b_{kn} \lambda_j^n \rightarrow 0. \quad (\text{A40})$$

Now consider

$$|\lambda_1|^n \sum_{k=0}^{p-1} \left[\sum_{j=1}^{J_1} B_{jk} \left(\frac{\lambda_j}{|\lambda_1|} \right)^n \right] b_{kn} \rightarrow 0. \quad (\text{A41})$$

If

$$|\lambda_j| < |\lambda_1|, \quad j > J_{11}, \quad (\text{A42})$$

then

$$\sum_{k=0}^{p-1} \left(\sum_{j=1}^{J_{11}} B_{jk} \rho_j^n \right) b_{kn} \rightarrow 0, \quad \rho_j = \lambda_j / |\lambda_1|, \quad 1 \leq j \leq J_{11}, \quad (\text{A43})$$

$$\sum_{k=0}^{p-1} \left(\sum_{j=1}^{J_{11}} B_{jk} \rho_j^n \right) \frac{b_{kn}}{b_{p-1 n}} \rightarrow 0, \quad 0 \leq k \leq p-1. \quad (\text{A44})$$

Since

$$\frac{b_{kn}}{b_{p-1 n}} \rightarrow \delta_{k p-1}, \quad 0 \leq k \leq p-1, \quad (\text{A45})$$

$$\sum_{j=1}^{J_{11}} B_{j p-1} \rho_j^n \rightarrow 0. \quad (\text{A46})$$

Using (A46) in (A43)

$$\sum_{k=0}^{p-2} \left(\sum_{j=1}^{J_{11}} B_{jk} \rho_j^n \right) b_{kn} \rightarrow 0. \quad (A47)$$

Repeating the same procedure, it follows that

$$\sum_{j=1}^{J_{11}} B_{jk} \rho_j^n \rightarrow 0, \quad 0 \leq k \leq p-1. \quad (A48)$$

Now, note that the equations

$$\sum_{j=1}^{J_{11}} \rho_j^{n+i} B_{jk} \rightarrow 0, \quad 0 \leq i \leq J_{11} - 1, \quad 0 \leq k \leq p-1, \quad (A49)$$

can be expressed in matrix notation as

$$\bar{\rho} \rho^n \bar{B} \rightarrow 0, \quad (A50)$$

where $\rho = \text{diag} (\rho_j)$,

$$\bar{\rho} = \begin{pmatrix} 1 & 1 & \dots & 1 \\ \rho_1 & \rho_2 & \dots & \rho_{J_{11}} \\ \vdots & & & \\ \rho_1^{J_{11}-1} & & & \rho_{J_{11}}^{J_{11}-1} \end{pmatrix} \quad (A51)$$

and where \bar{B} is the matrix formed by the appropriate elements of the matrices B_{jk} . Further note that $\bar{\rho}$ is invertible since the ρ_j 's are distinct.

$$\rho^n \bar{B} \rightarrow 0, \quad \rho_j^n B_{jk} \rightarrow 0, \quad |\rho_j| = 1, \quad j < J_{11} \quad (A52)$$

$$\therefore B_{jk} = 0, \quad 0 \leq k \leq p-1, \quad 1 \leq j \leq J_{11}. \quad (A53)$$

Now substitute (A53) into (A40) to obtain

$$\sum_{j=J_{11}+1}^{J_1} \sum_{k=0}^{p-1} B_{jk} \rho_{kn} \lambda_j^n \rightarrow 0. \quad (A54)$$

$$\prod_{k=0}^{p-1} \left(\sum_{j=J_{11}+1}^{J_1} B_{jk} \rho_j^n \right) b_{kn} \rightarrow 0, \quad \rho_j = \lambda_j / |\lambda_{J_{11}+1}|, \quad J_{11} < j \leq J_{12} \quad (A55)$$

Repeating the same procedure as many times as necessary, it follows that

$$B_{jk} = 0, \quad 0 \leq k \leq p-1, \quad 1 \leq j \leq J_1, \quad (A56)$$

which is the desired result.

Theorem 1

Let (C, ϕ, Γ) be output stabilizable. Then $C \phi^n \Gamma \rightarrow 0$ if, and only if $\rho(\phi) < 1$.

Comment: Note that if (C, ϕ, Γ) is output stabilizable then $(C, \phi(K), \Gamma)$ is output stabilizable where $\phi(K)$ is defined in (13). The Theorem is used for the $(C, \phi(K), \Gamma)$ system in Lemma 6 but is proved here using (C, ϕ, Γ) .

Proof: If $\rho(\phi) < 1$, then $\phi^n \rightarrow 0$; thus $C \phi^n \Gamma \rightarrow 0$. Now suppose that $\rho(\phi) \geq 1$ and $C \phi^n \Gamma \rightarrow 0$; let λ_j be an eigenvalue such that $|\lambda_j| \geq 1$. By Lemma A4,

$$B_{jk} = \sum_{\ell=\ell_j}^{\ell_{j+1}-1} A_{\ell k} \lambda_j^{-k} = 0, \quad 0 \leq k \leq p-1. \quad (A57)$$

$$\lambda_j^k B_{jk} = \sum_{\ell=\ell_j}^{\ell_{j+1}-1} \prod_{i=1}^{p-\ell-k} \alpha_{\ell+i} \beta_{\ell i} \Pi_k p_{\ell-1} = 0, \quad 0 \leq k \leq p-1. \quad (A58)$$

Now let $\ell_{j+1} = \ell_j + q + 1$, $q \geq 0$; i.e., λ_j corresponds to $q + 1$ Jordan forms.

It follows that λ_j corresponds to $q + 1$ linearly independent eigenvectors, namely $\{x_{\ell_j+i} p_{\ell_j+i}, 0 \leq i \leq q\}$. It is important to note the implications of Lemma A1 to the multiple eigenvector case. Thus, let $\{x_i, 0 \leq i \leq q\}$ be a set of linearly independent set of eigenvectors corresponding to the eigenvalue λ ; i.e.,

$$\phi x_i = \lambda x_i, \quad 0 \leq i \leq q. \quad (A59)$$

Then for any non-zero sequence $\{a_i, 0 \leq i \leq q\}$ of complex numbers, the vector

$$x = \sum_{i=0}^q a_i x_i \quad (\text{A60})$$

is also an eigenvector of ϕ corresponding to λ .

Hence, Lemma A1 implies that

$$Cx = \sum_{i=0}^q a_i Cx_i \neq 0 \quad (\text{A61})$$

whenever $|\lambda| \geq 1$, provided that (C, ϕ, Γ) is output stabilizable. In other words, the set of vectors $\{Cx_i, 0 \leq i \leq q\}$ is linearly independent. For the problem at hand, it follows that the set $\{\alpha_{\ell} p_{\ell}, \ell_j \leq \ell < \ell_{j+1} = \ell_j + q + 1\}$ is linearly independent. Similarly, it can be shown that $\{\beta_{\ell} p_{\ell}, \ell_j \leq \ell < \ell_{j+1}\}$ is linearly independent.

Now let $\bar{p}_j = \max \{p_{\ell}, \ell_j \leq \ell < \ell_{j+1}\}$, and $1 \leq m \leq \bar{p}_j$. We will show that (A57) implies

$$\beta_{\ell i} = 0, \quad 1 \leq i \leq p_{\ell} - \bar{p}_j + m, \quad 1 \leq m \leq \bar{p}_j, \quad (\text{A62})$$

using finite induction. First note (A62) holds for $m = 1$, by evaluating (A58) for $k = \bar{p}_j - 1$.

$$\sum_{\ell=\ell_j}^{\ell_j+q} p_{\ell-\bar{p}_j+1} \sum_{i=1}^{\bar{p}_j} \alpha_{\ell} \beta_{\ell i} \Pi_{\bar{p}_j-1} p_{\ell-1} = 0 \quad (\text{A63})$$

$$\sum_{\ell=\ell_j}^{\ell_j+q} \alpha_{\ell} p_{\ell} \beta_{\ell 1} \Pi_{\bar{p}_j} p_{\ell} = 0 \quad (\text{A64})$$

where the fact that $p_{\ell} - \bar{p}_j + 1 \leq 1$ has been used to obtain (A64). Since the $\alpha_{\ell} p_{\ell}$'s are linearly independent, it follows that

$$\beta_{\ell 1} \Pi_{\bar{p}_j} p_{\ell} = 0; \quad \text{i.e.,} \quad \beta_{\ell i} = 0, \quad 1 \leq i \leq p_{\ell} - \bar{p}_j + 1. \quad (\text{A65})$$

Now suppose that (A62) holds for an arbitrary value $m < \bar{p}_j$. Evaluating

(A58) for $k = p_j - m - 1$, we obtain

$$\sum_{\ell=\ell_j}^{\ell_j+q} p_{\ell}^{-\bar{p}_j+m+1} \alpha_{\ell} \beta_{\ell} \prod_{i=1}^{\ell} p_{i+\bar{p}_j-m-1} \beta_{\ell i} \prod_{\bar{p}_j-m-1}^{\ell} p_{\ell}^{-1} = 0 \quad . \quad (\text{A66})$$

Since (A62) holds for m , the only terms which might not vanish correspond to $1 \leq i = p_{\ell} - \bar{p}_j + m + 1$. Hence (A66) becomes

$$\sum_{\ell=\ell_j}^{\ell_j+q} \alpha_{\ell} p_{\ell} \beta_{\ell} p_{\ell}^{-\bar{p}_j+m+1} \prod_{\bar{p}_j-m}^{\ell} p_{\ell} = 0 \quad (\text{A67})$$

Since the $\alpha_{\ell} p_{\ell}$'s are linearly independent,

$$\beta_{\ell} p_{\ell}^{-\bar{p}_j+m+1} \prod_{\bar{p}_j-m}^{\ell} p_{\ell} = 0, \quad \ell_j \leq \ell \leq \ell_j + q \quad . \quad (\text{A68})$$

$$\beta_{\ell i} = 0, \quad 1 \leq i = p_{\ell} - \bar{p}_j + m + 1; \quad (\text{A69})$$

so that (A62) must hold for $m + 1$, and by induction for $1 \leq m \leq \bar{p}_j$.

However, if (A62) holds for $m = \bar{p}_j$, then

$$\beta_{\ell} p_{\ell} = 0, \quad \ell_j \leq \ell < \ell_{j+1} \quad (\text{A70})$$

which, by Lemma 1, implies that (C, ϕ, Γ) is not output stabilizable, a contradiction. Thus, we must have $\rho(\phi) < 1$ which concludes the proof.

Finally, an inequality that is used throughout the paper is given in Lemma A5 for completeness.

Lemma A5

Let P_1, P_2, W be non-negative definite (and Hermitian) matrices such that $P_1 \geq P_2 \geq 0$. Then

$$\text{tr} \{P_1 \quad W\} \geq \text{tr} \{P_2 \quad W\} \geq 0 \quad (\text{A71})$$

Proof: Since $W \geq 0$, let

$$W = \omega \omega^H \tag{A72}$$

$$\text{tr} \{ P_1 W \} = \text{tr} \{ \omega^H P_1 \omega \} \geq \text{tr} \{ \omega^H P_2 \omega \} \geq 0.$$

Note that whereas $P_1 W$ need not be non-negative definite, its trace is non-negative.

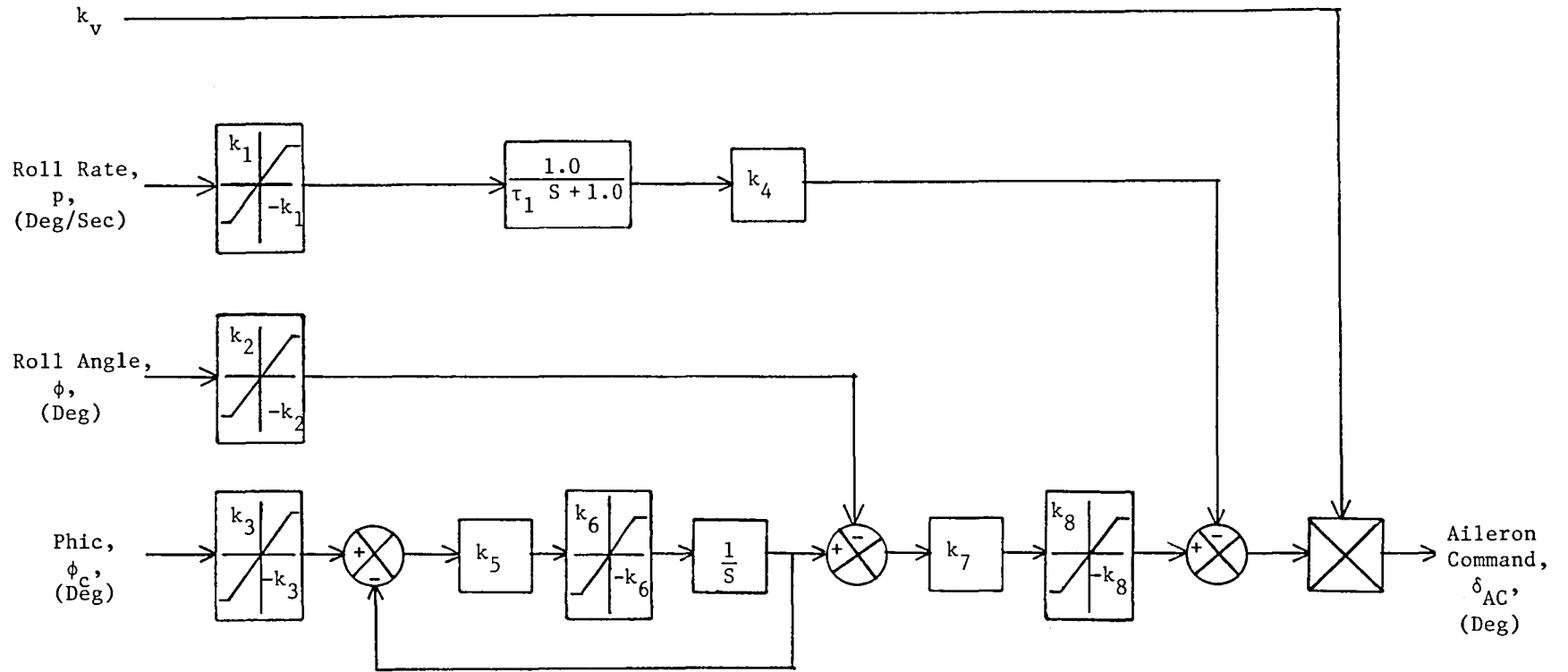

FIGURE 1 LATERAL-DIRECTIONAL INNER-LOOP BLOCK DIAGRAMS

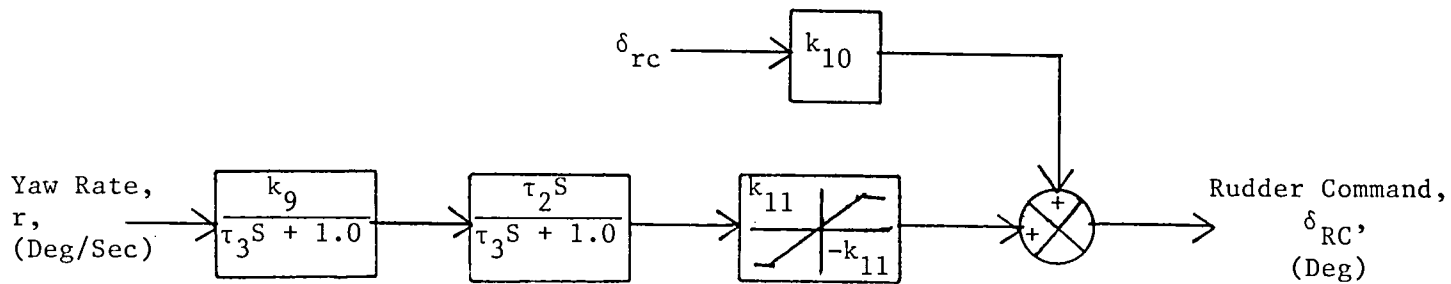

FIGURE 1 LATERAL-DIRECTIONAL INNER-LOOP BLOCK DIAGRAMS (CONCLUDED)

TABLE 1 EFFECTS OF CHANGING NOISE COVARIANCE MATRICES^{§¶}

Design Parameters	Gain Matrix			Eigenvalues								
	$\Delta \underline{u}' = [\Delta \phi_c, \Delta \delta_{rc}]$ $\Delta \underline{y}' = [\Delta \psi, \Delta y, \Delta \dot{y}]$			Δy	$\Delta \psi$	Δr_{wo}	Spiral	Dutch Roll	Roll	$\hat{\Delta \phi}$	$\hat{\Delta r}, \Delta \delta_a$	$\hat{\Delta p}$
Outer-loop Open Inner-loop Closed	0			0.0	0.0	-0.279	-1.06	-0.94±j0.80	-3.67	-5.0	(-6.3±j1.7)	-22.4
Observation Noise: $\sigma_{\psi} = 0.1$ $\sigma_y = 3.05$ $\sigma_{\dot{y}} = 3.05$	-0.98	-0.016	-0.061	(-0.32±j0.26)	-0.171	-0.436	-0.95±j1.3	-2.85	-5.0	(-6.2±j2.0)	-22.4	
Observation Noise: $\sigma_{\psi} = 0.32$ $\sigma_y = 2.16$ $\sigma_{\dot{y}} = 0.67$	-0.90	-0.015	-0.064	(-0.32±j0.27)	-0.155	-0.446	-0.95±j1.2	-2.86	-5.0	(-6.2±j2.0)	-22.4	
Observation Noise as Above Using Gusts & Inner-loop Measurement Noise Only	-0.073	-0.0046	-0.036	(-0.059±j.014)	-0.243	-0.914	-0.89±j0.92	-3.95	-5.0	(-6.2±j1.7)	-22.4	

[§] Angles-deg, Angular Rates-deg/sec, Velocity-m/sec, Gusts-m/sec, Position-m

[¶] The equivalent continuous-time closed-loop eigenvalues are obtained by applying first the log of a matrix to the discrete closed-loop plant then finding the eigenvalues of the resulting matrix.

TABLE 2 DIAGONAL ELEMENTS* OF DESIGNED MATRICES

R - Control Weighting	
$r_{\phi_c \phi_c} = 1.0$	$r_{\delta_{rc} \delta_{rc}} = 1.0$
Q - State Weighting	
$q_{\psi\psi} = 0.25, q_{\phi\phi} = 0.25, q_{yy} = 0.00093, q_{\dot{y}\dot{y}} = 0.023$	
W - Process Noise	
$\sigma_{wg} = 3.05, \sigma_p = 0.3, \sigma_\phi = 0.6, \sigma_r = 0.3$	
W+ - Additional Process Noise (Initial Condition State Variance)	
$\sigma_v = 1.5, \sigma_\phi = 5.0, \sigma_\psi = 5.0, \sigma_y = 30.5,$	
$\sigma_{\hat{r}} = 1.0, \sigma_{\hat{p}} = 1.0, \sigma_{\hat{\phi}} = 1.0, \sigma_{r_{wo}} = 1.0$	

*Angles-deg, Angular Rates-deg/sec, Velocity-m/sec, Gusts-m/sec, Position-m

TABLE 3 ALGORITHM COMPARISONS

Minimization Technique	Algorithm I (Algorithm III with $\alpha = 1.0$)	Algorithm II (Davidon-Fletcher-Powell)	Algorithm III (Section V)
Test 1:			
Initial Value for $J(K_0)$	179.048	179.048	179.048 ($\alpha=1.0$ to start)
No. of Lyapunov Type Equations Solved	4	122	88
Final Value for $J(K)$	--- Diverged	176.740 Algorithm Prematurely Terminated Because of Poor Convergence	173.605 Converged-Final $\alpha = 0.75$
Test 2:			
Initial Value for $J(K_0)$	173.643	173.643	173.643 ($\alpha=1.0$ to start)
No. of Lyapunov Type Equations Solved	4	80	24
Final Value for $J(K)$	--- Diverged	173.606 Converged	173.606 Converged-Final $\alpha = 0.75$

1. Report No. NASA CR-3828		2. Government Accession No.		3. Recipient's Catalog No.	
4. Title and Subtitle INVESTIGATION, DEVELOPMENT, AND APPLICATION OF OPTIMAL OUTPUT FEEDBACK THEORY. Volume I—A Convergent Algorithm for the Stochastic Infinite-Time Discrete Optimal Output Feedback Problem				5. Report Date August 1984	
				6. Performing Organization Code	
7. Author(s) Nesim Halyo and John R. Broussard				8. Performing Organization Report No. FR 683101	
9. Performing Organization Name and Address Information & Control Systems, Incorporated 28 Research Drive Hampton, VA 23666				10. Work Unit No.	
				11. Contract or Grant No. NAS1-15759	
12. Sponsoring Agency Name and Address National Aeronautics and Space Administration Washington, DC 20546				13. Type of Report and Period Covered Contractor Report	
				14. Sponsoring Agency Code 534-04-13-54	
15. Supplementary Notes NASA Langley Technical Monitor: Richard M. Hueschen Final Report					
16. Abstract <p>This report considers the stochastic, infinite-time, discrete output feedback problem for time-invariant linear systems. Two sets of sufficient conditions for the existence of a stable, globally optimal solution are presented. An expression for the total change in the cost function due to a change in the feedback gain is obtained. This expression is used to show that a sequence of gains can be obtained by an algorithm, so that the corresponding cost sequence is monotonically decreasing and the corresponding sequence of the cost gradients converges to zero. The algorithm is guaranteed to obtain a critical point of the cost function. The computational steps necessary to implement the algorithm on a computer are presented. The results are applied to a digital outer-loop flight control problem. The numerical results for this 13th order problem indicate a rate of convergence considerably faster than two other algorithms used for comparison when they converge.</p>					
17. Key Words (Suggested by Author(s)) Optimal Control - Theory Optimal Control - Application Output Feedback Numerical Algorithms			18. Distribution Statement Unclassified - Unlimited Subject Category 08		
19. Security Classif. (of this report) Unclassified		20. Security Classif. (of this page) Unclassified		21. No. of Pages 55	22. Price A04



National Aeronautics and
Space Administration

Washington, D.C.
20546

Official Business

Penalty for Private Use, \$300

THIRD-CLASS BULK RATE

Postage and Fees Paid
National Aeronautics and
Space Administration
NASA-451



NASA

POSTMASTER: If Undeliverable (Section 158
Postal Manual) Do Not Return
