

APPLICATION OF TOS/AMS TO TDRS E & F

OSC

MARTIN MARIETTA

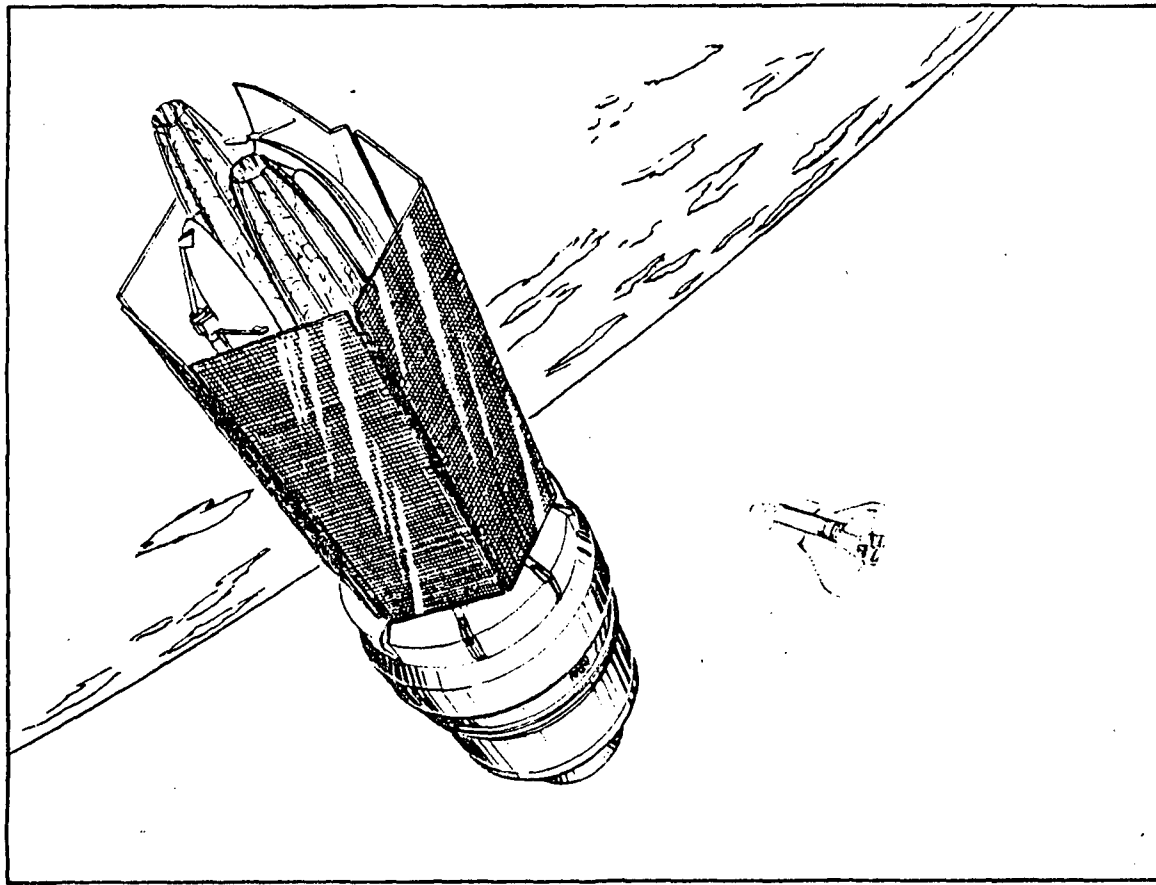

184-31225

**FINAL REPORT
MAY 30 1984
NASA CONTRACT NO.
NAS 8-35-617**

DR1

FOREWORD

This final report is for NASA Contract NAS8-35-617 encompassing the application of the Transfer Orbit Stage (TOS) and Apogee Maneuvering Stage (AMS) for the TDRS-E and F Spacecraft missions. Martin Marietta is presently under contract to Orbital Sciences Corporation (OSC) to develop a TOS and conduct a vehicle definition study for an AMS that would be used in conjunction with TOS. Utilizing the TOS/AMS data generated under these contracts as the baseline vehicle system, Martin Marietta performed a mission specific study for TDRS. The contract statement-of-work tasks are identified for each section. The results of Tasks 3.1.8 and 3.1.9 involving costs are provided separately by the Orbital Sciences Corporation.

CONTENTS

QSC

MARTIN MARIETTA

	<u>PAGE</u>
1.0 PROGRAM OVERVIEW AND SUMMARY	3
- STUDY OBJECTIVE	
- REQUIREMENTS	
- CONFIGURATION CONCEPT FOR TDRS	
- SCHEDULE (3.1.10)	
- SUMMARY OF TDRS STUDY TASKS	
2.0 TDRS REQUIREMENTS AND SYSTEM DESIGN	19
- TDRS REQMTS/COMPLIANCE	
- KEY DESIGN DRIVERS	
- SYSTEM DESIGN	
- ENVIRONMENTAL EFFECTS (3.1.7)	
3.0 PERFORMANCE ASSESSMENT (3.1.1)	46
OPERATIONS ANALYSIS (3.1.13)	
SPECIAL SERVICES AND SUPPORTING ITEMS (3.1.7)	
4.0 ACCURACY ASSESSMENT (3.1.2)	63
ATTITUDE CONTROL ANALYSIS (3.1.6)	
AVIONICS KITS (3.1.5)	
5.0 INTERFACE ADAPTER DEFINITION (3.1.4)	85
THERMAL ANALYSIS (3.1.5)	
STRUCTURE ANALYSIS (3.1.3)	
6.0 ORBITER SAFETY REQUIREMENTS (3.1.11)	105

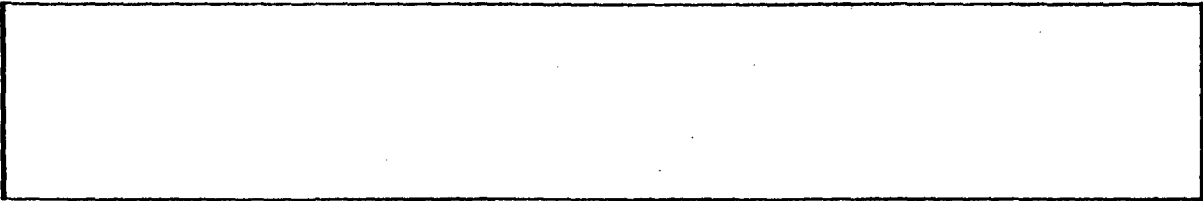

OSC

MARTIN MARIETTA

1.0 PROGRAM OVERVIEW AND SUMMARY

AMS AND TDRS STUDY OBJECTIVE

Martin Marietta is presently under contract to Orbital Sciences Corporation (OSC) to develop a Transfer Orbit Stage (TOS) and conduct a study for an Apogee and Maneuvering Stage (AMS) that would be used in conjunction with TOS.

The AMS study with OSC is to provide a low cost reliable space transportation system and services for commercial and government users. To accomplish this, the AMS makes maximum use of space qualified hardware and is capable of serving the widest possible market. The AMS primary application is the second stage to the TOS. In this configuration the TOS/AMS provides capability to geosynchronous orbit of approximately 6000 lbs. Definition of the generic AMS included a detailed design concept with layout drawings, component definition, performance, accuracy, STS and spacecraft interface definition, schedules, cost estimates, and specification documents for the Vehicle, Airborne Support Equipment, and Ground Support Equipment. A primary objective in the AMS study was to make maximum use of hardware and concepts under development for TOS.

Utilizing the TOS/AMS data generated under these contracts as the baseline vehicle system, Martin Marietta performed a mission specific study for the TDRS E and F spacecraft. The objective of the study was to identify the changes to the basic OSC TOS/AMS system, if any, to permit the TDRS spacecraft to be placed in its final operational geosynchronous orbit. We were to assume no changes to the current TDRS spacecraft and its interfaces. Unique TDRS requirements would be provided by the use of kits.

AMS AND TDRS STUDY OBJECTIVE

QSC

MARTIN MARIETTA

GENERIC AMS

PROVIDE DEFINITION OF A RESTARTABLE, BI-PROPELLANT APOGEE STAGE THAT CAN BE USED IN CONJUNCTION WITH TOS

- DETAILED DESIGN CONCEPTS
- PERFORMANCE
- INTERFACE SPECIFICATIONS
- SCHEDULES
- COST ESTIMATES
- MAKE MAXIMUM USE OF TOS HARDWARE

TDRS STUDY

IDENTIFY CHANGES TO THE BASIC TOS/AMS SYSTEM, IF ANY, FOR DELIVERY OF TDRS E & F SPACECRAFT TO FINAL GEO ORBIT

- ASSUME "NO CHANGES" TO TDRS SPACECRAFT AND ITS INTERFACES
- PROVIDE FOR TDRS UNIQUE REQUIREMENTS BY USE OF KITS

0116-15-WP

TOS TECHNICAL BASELINE SUPPORTS TOS/AMS DEVELOPMENT

The TOS is a medium-capacity Space Shuttle upper stage that has been in full-scale development since 1983 by Martin Marietta Denver Aerospace. The TOS fills the gap in Space Shuttle payload delivery capability between the Payload Assist Module (PAM) upper stages produced by McDonnell Douglas Corporation and the higher performance Centaur upper stage being developed by NASA and the Air Force. A three-axis stabilized perigee stage, the TOS will be used to launch commercial satellites and a variety of government payloads from the Shuttle's low-Earth orbit to higher orbits such as geosynchronous transfer orbit and interplanetary escape trajectories. The vehicle design is based on the solid-propellant first-stage motor used in the Inertial Upper Stage (IUS) and on other space-proven hardware. This hardware include the hydrazine Reaction Control System (RCS) using the IUS thrusters, the Ring Laser Gyro with built in computer unit, two 20 Ah batteries from Peacekeeper for power, and passive thermal control. The TOS forward skirt has a dual spacecraft interface for 76 in. diameter Arian or 92 in. diameter.

The direct mount Airborne Support Equipment (ASE) consists of the forward cradle, aft cradle, longitudinal links, and the mechanisms for deploying the flight vehicle. The forward cradle employs a unique feature in that it completely encircles the forward skirt of the TOS. This full frame reduces deflections in the frame resulting in increased stiffness compared to conventional U-shaped cradles. This design has provided significant weight reduction. The electrical ASE is implemented using an existing orbiter control and display panel (SSP), simple relay control circuits, and flight-proven batteries to power the deployment ordnance and actuator motors. The display of selected data such as actuator position and some safing information is on the orbiter display unit via the multiplexer-demultiplexer (MDM) and general purpose computer because of SSP limitations.

TOS TECHNICAL BASELINE SUPPORTS TOS/AMS DEVELOPMENT

OSC

MARTIN MARIETTA

PRESENT BASELINE

VEHICLE

- DUAL INTERFACE FWD SKIRT
- MAIN PROPULSION-IUS SRM
- RCS PROPULSION-HYDRAZINE BLOWDOWN USING IUS REMS
- RLG/COMPUTER UNIT
- TWO 20 AH BATTERIES
- PASSIVE THERMAL CONTROL

ASE

- LIGHTWEIGHT, DIRECT MOUNT
- SUPERZIP 9" SEPARATION SYSTEM
- THREE 20 AH BATTERIES

STS INTERFACE

- ORBITER POWER (HEATERS)
- CONTROL AND DISPLAY (SSP & MDM)
- TELEMETRY

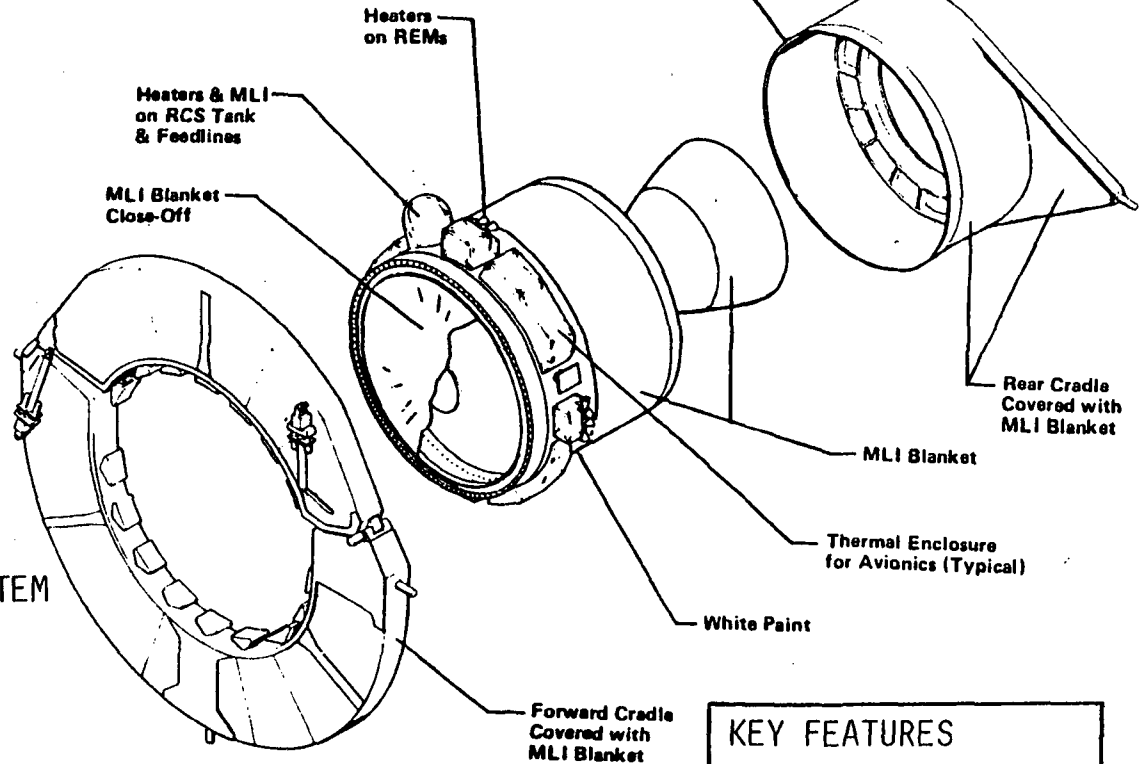

KEY FEATURES
PERF. 13,000 TO 6T0
ILC LATE 1986
RELIABILITY > 0.96

TOS/AMS GENERIC BASELINE UTILIZES SUBSTANTIAL TOS HARDWARE

The TOS/AMS is a two-stage vehicle. The first stage is a modified version of TOS described previously. The second stage is a storable, bipropellant AMS that provides accurate multiburn capability. TOS/AMS is ideally suited for delivery of payloads into geosynchronous or other high-altitude orbits and for a variety of planetary missions. The configuration offers delivery of approximately 6000 lb to synchronous equatorial orbit; the similar VRM configuration offers up to 12,396 ft/s delta-V to a 3600-kg (7936-lb) spacecraft.

The AMS is a liquid bipropellant propulsion module that has numerous space transportation applications operating independently of, or in conjunction with, the TOS. Operating autonomously, the AMS can be deployed from the Space Shuttle to perform missions that include low-orbit maneuvering between the Shuttle and NASA's planned space station, delivery of payloads to Sun-synchronous and polar orbits, and delivery of communications and other satellites to geosynchronous transfer orbit. Space-storable propellants used in the AMS enable it to perform subsequent maneuvers and orbit changes over extended periods. Design work on the AMS began in 1983. Under contract to OSC, Martin Marietta has completed system definition studies, including extensive thermal, structural, dynamics, reliability, and safety analyses.

The AMS design has made maximum use of TOS hardware presently under development. The following hardware is presently being designed to satisfy both TOS and AMS without any change. The Ring Laser Gyro is dual redundant on AMS and is the identical unit as used on TOS. The Majority Vote Sequencer meets both the TOS and AMS requirements. Components such as the PIC box, motor driven switches, and diodes are identical. All of the RCS components on TOS will be used on AMS. The SRM motor and thrust vector controllers are the identical units to IUS and TOS. For new spacecraft that do not require a soft suspension system the direct mount cradle is used. The direct mount cradle for TOS/AMS uses the same aft cradle as TOS; however, the forward cradle is modified to accommodate the larger diameter of AMS. The concept and mechanisms are identical to TOS.

TOS/AMS GENERIC BASELINE UTILIZES SUBSTANTIAL TOS HARDWARE

OSC

MARTIN MARIETTA

VEHICLE

- IUS S/C INTERFACE
- AL SKIN STRINGER DESIGN
- MAIN PROPULSION
 - IUS SRM 1ST STAGE
 - BI-PROPELLANT RESTART ENGINE (PK 4TH STAGE)
- HYDRAZINE BLOWDOWN SYS. W/IUS REMS
- DUAL REDUNDANT RLG
- TWO 175 AH BATTERIES
- TELEMETRY
- S/C ELECTRICAL POWER

EQUIPMENT FROM TOS

- RLG
- MAJORITY VOTE SEQUENCER
- PIC BOX
- MOTOR DRIVEN SWITCH'S
- DIODES
- RCS COMPONENT'S
- SRM

0112G-16-WP

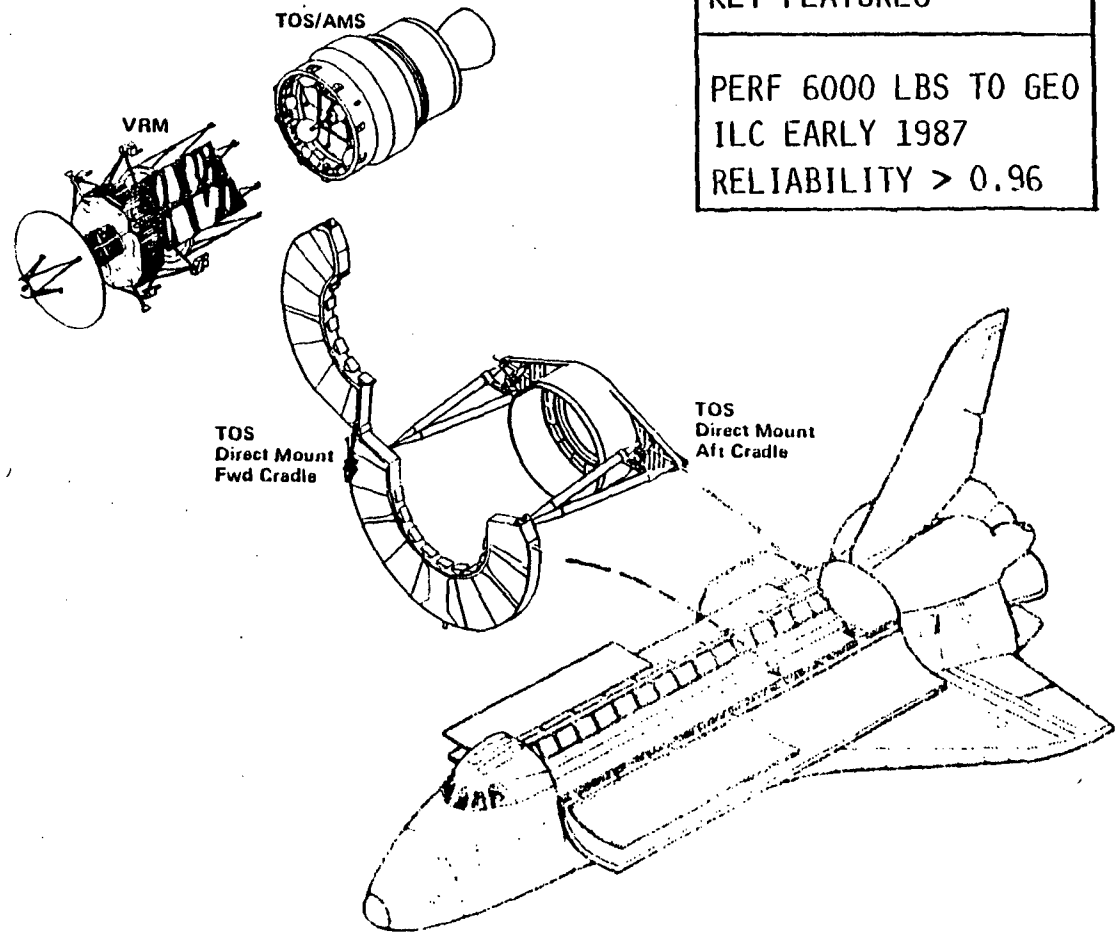

KEY FEATURES

PERF 6000 LBS TO GEO
ILC EARLY 1987
RELIABILITY > 0.96

TOS/AMS CONFIGURATION FOR TDRS

The TOS/AMS being proposed is the best propulsion system to place the TDRS-E and TDRS-F spacecraft into geosynchronous orbit (GSO). The excellent injection accuracy and high-propellant capacity of the TOS/AMS provides increased TDRS on-orbit service life and spacecraft weight growth potential. The TOS/AMS has been designed to assure that no changes will be required to the TDRS spacecraft. This includes use of the IUS load-alleviated cradle to provide a "soft ride" for the TDRS spacecraft. The TOS/AMS is a highly reliable, low-cost alternative to the IUS and Centaur upper stages. The spacecraft interface is the same eight point support as IUS. Injection accuracy from three sigma delivery to zero-zero correction is equivalent to 71 lbs of TDRS hydrazine propellant. In addition the TOS/AMS for TDRS provides a delivery capability of 5800 lbs, reliability greater than 0.96, and an initial launch capability of early 1987 can be achieved.

The modifications of TOS/AMS for TDRS include use of the IUS cradle and electrical connectors, a power kit and telemetry and command kit. The TOS/AMS is designed for use with the IUS cradle or the direct mount cradle. The command kit is for shutdown of the AMS sequencer for safety. The telemetry is designed for compatibility with STDN.

TOS/AMS CONFIGURATION FOR TDRS

DSC

MARTIN MARIETTA

VEHICLE HIGHLIGHTS

- STS COMPATIBILITY
- SPACECRAFT I/F SAME AS IUS
- INJECTION ACCURACY AT GEO EQUIV TO 71 LB HYDRAZINE
- MAXIMUM USE OF TOS HARDWARE
- MAXIMUM USE OF FLIGHT QUALIFIED HARDWARE

TOS/AMS MODIFICATIONS FOR TDRS

- IUS ASE (CRADLE)
- ASE ELECTRICAL CONNECTORS
- POWER KIT
- TELEMETRY AND COMMAND KIT

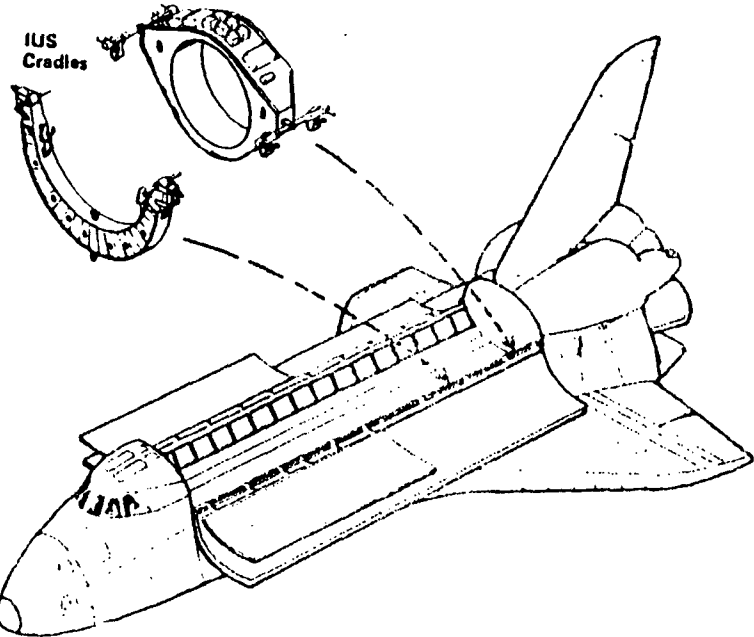
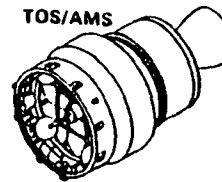
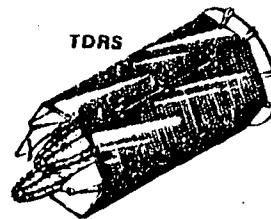

KEY FEATURES
PERF 5800 LBS TO GEO
ILC EARLY 1987
RELIABILITY > 0.96

TOS/AMS CONFIGURATION SATISFIES ALL TDRS REQUIREMENTS

KEY REQUIREMENTS AND HOW ACCOMMODATED

The facing page summarized the key TDRS requirements and shows how they are accommodated by the TOS/AMS as compared to the IUS. In all cases the TOS/AMS meets the requirements equivalent to IUS and in two key instances surpasses the IUS. These are delivery performance and accuracy. The performance requirement of 5000 lbs is just met by IUS but for TOS/AMS it is exceeded by 800 lbs. The TDRS B requirement for accuracy as related to spacecraft propellant, is 123 lbs hydrazine. For TOS/AMS only 71 lbs of hydrazine would be required.

The 8 point structural interface for IUS will be the same for TOS/AMS and was originally derived from the Titan Transtage built by Martin Marietta. Structural dynamic characteristics are met by TOS/AMS through use of the IUS cradle. We have performed the detail dynamic analysis for both STS lift-off, and landing to assure compatibility. Furthermore, we have coordinated the analysis with NASA Goddard on 20 key node points and confirmed there are no loads that exceed TDRS requirements.

The power and telemetry requirements for TDRS are met through the use of kits. Discrete issuance is met through the use of our redundant sequencer.

QSC**MARTIN MARIETTA**

KEY REQUIREMENTS AND HOW ACCOMMODATED

<u>REQUIREMENTS</u>	<u>HOW ACCOMMODATED BY IUS</u>	<u>HOW ACCOMMODATED BY TOS/AMS</u>
<u>PERFORMANCE</u> - 5000 LB TO GEO	- 5000 LBS	- 5800 LBS
<u>ACCURACY</u> - TDRS A REQMT (S/C PROP) - TDRS B REQMT (S/C PROP)	- 37 LBS HYDRAZINE - 123 LBS HYDRAZINE	- 71 LBS HYDRAZINE - 71 LBS HYDRAZINE
<u>STRUCTURAL</u> - MECHANICAL, 8 ATTACH POINTS - DYNAMICS FOR L. O. & LANDING	- 8 BOLT I/F - SOFT SUPP. SYS	- SAME AS IUS - SAME AS IUS
<u>THERMAL</u> - INITIATE MANEUVERS ≤ 16 MIN - ROLL RATE 3 ± 0.3 DEG/S	- FLT DESIGN PROFILE - HYDRAZINE RCS	- SAME AS IUS - SAME RCS AS IUS
<u>CONTAMINATION</u> - IMPINGEMENT/CONTAMINANTS	- SOLID/SOLID/HYD	- SOLID/BI-PROP/HYD
<u>POWER</u> - BEFORE LAUNCH THRU S/C SEP.	- ORBITER/ASE/STAGE	- ORBITER/ASE/POWER KIT
<u>TELEMETRY/COMMUNICATIONS</u> - TELEMETRY TO ORBITER - TELEMETRY TO GROUND - 8 PRIMARY & BACKUP DISCRETES	- ELEC I/F TO ORBITER - TELEM & COMMAND - IUS REDUND SEQUENCER	- SAME AS IUS - TELEM & COMMAND KIT - AMS REDUND. SEQUENCER

TOS/AMS FOR TDRS IS EFFICIENTLY PACKAGED

The TOS/AMS is a compact stage that efficiently packages all other subsystem components to meet TDRS strength and performance requirements. The short AMS design (88 in. including adapter to TOS) permitted us to move the forward IUS cradle 11.8 in. aft of its current orbiter position to obtain the overall stage length of 15.9 ft. The forward skirt avionics are shown separated from the vehicle for clarity, and all significant components are identified.

The basic structure is aluminum skin stringer design with its heritage from our Titan and Titan Transtage. The design is conservative in that no composites are used and a 20% weight contingency is carried on all new or modified hardware including the structure and a 5% weight contingency is carried on all existing hardware.

Thermal control is maintained by the use of coatings MLI, and gold plated stainless steel on the bottom of the propellant tanks to protect them from the environment created by the AMS axial engine. Heaters are placed on the hydrazine and oxidizer tanks and lines to prevent freezing. Redundant thermostats control their use.

Separation of the AMS from TOS is by use of 8 low shock gas operated (pyrotechnic) nuts and springs. Upon solid motor burnout, separation is delayed 40 seconds for tailoff followed by separation and RCS activation to provide propellant setting (10 sec) prior to the first AMS axial engine burn at perogee.

TOS/AMS FOR TDRS IS EFFICIENTLY PACKAGED

Osc

MARTIN MARIETTA

Item	
1	Antenna (2)
2	Propulsion Servicing Panel
3	Relay Box
4	Diodes (5)
5	PIC (6)
6	Majority Vote Sequencer
7	Motor Driven Switch, (4)
8	Input/Output Unit
9	Laser Gyro (2)
10	Signal Conditioner (4)
11	Diplexer *
12	10V Power Supply Unit
13	RF Switch
14	PCM Encoder
15	S-Band Transponder *
16	Power Amplifier
17	175 AH Battery *

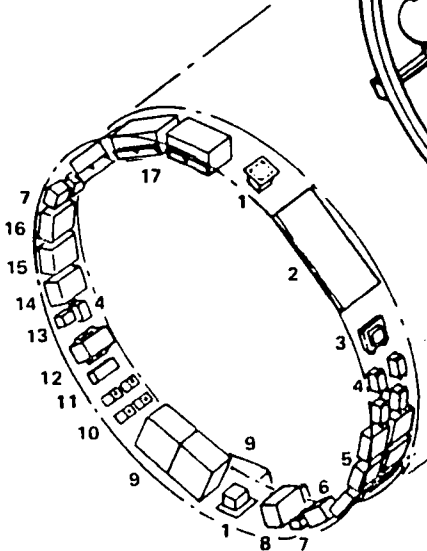
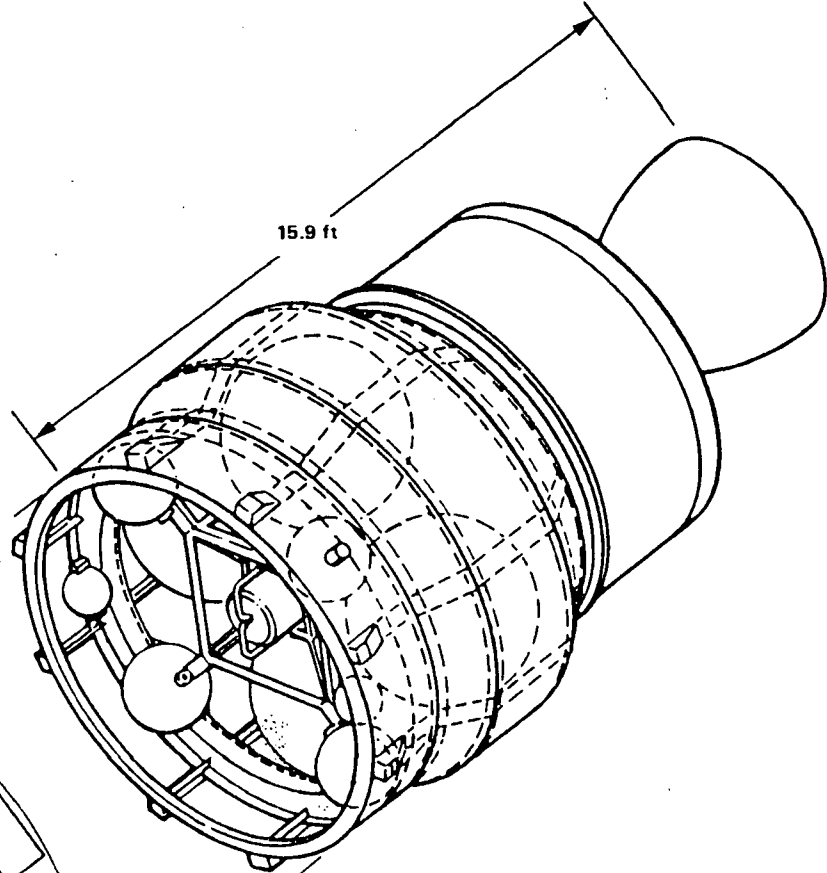

TDRS UNIQUE *	
11	DIPLEXER
15	S-BAND TRANSPONDER
17	175 AH BATTERY

AMS STRUCTURAL FEATURES

- AL SKIN STRINGER DESIGN
- 8 PYROTECHNIC BOLTS/
SPRING SEP FROM TOS
- THERMAL IS PASSIVE
WITH TANK AND LINE
HEATERS
- WEIGHT CONTINGENCY OF
5 % (EXISTING HARDWARE)
20% (NEW OR MODIFIED)

AVIONICS DESIGN EMPLOYS REDUNDANCY IN CRITICAL AREAS

TOS/AMS avionics requirements include accurate orbital placement, three-axis stabilization, and a 7-hour on-orbit mission duration. Shuttle capability dictates compliance with safety constraints defined in NHB1700.7A for series inhibits and delaying RCS activation until a safe separation distance has been reached. Special attention has been given to TDRS telemetry and power requirements as well as TDRS requirements, that relate to stability and limit cycle performance.

The TOS/AMS avionics, as shown in the facing page include (1) Guidance and Control (G&C), (2) Telemetry and Command, (3) Event Sequencing, (4) Electrical Power System, and (5) Software. Low cost has been achieved by maximizing use of TOS avionics and, where cost effective, minimizing Orbiter interfaces and services.

The G&C system provides preprogrammed guidance for TOS/AMS orbital placement and stable three-axis control during powered and coast flight. It is designed around redundant strapdown Ring Laser Gyro (RLG) systems operating in the prime/backup mode, an Input/Output Unit that interfaces with redundant SRM TVC controllers, SRM and AMS main engine actuators, and the RCS thrusters.

Off-the-shelf hardware has been used to design the telemetry and command kit (which is removable). A programmable Pulse-Code, Modulation (PCM) encoder formats a telemetry data stream that modulates the S-Band transponder. Up to 1000 bps of TDRS telemetry can be accommodated. RF transmitter output is increased with a 20 W power amplifier before being applied to the antenna system.

The event sequencing hardware includes: a TOS majority vote sequencer to issue mission discrettes; Pyro Initiator Controllers (PIC) that fire propulsion and separation ordnance; and a Titan relay assembly to route firing currents to the selected ordnance device. This design satisfies the STS safety requirement for three series electrical inhibits and provides the reliability necessary for mission success.

The electrical power system is made up of redundant Titan batteries controlled by highly-reliable IUS/TOS motor-driven switches. A dedicated power kit has been designated to supply TDRS electrical power on-orbit.

The sequencer software controls timing of mission discrettes. Guidance and control software provides preprogrammed maneuvers and stability in powered and coast flight. Software architecture will be based on designs used on Transtage and Viking.

AVIONICS DESIGN EMPLOYS REDUNDANCY IN CRITICAL AREAS



REDUNDANCY

- o DUAL RLG
- o REDUNDANT SEQUENCER
- o DUAL BATTERIES
- o SRM ACTUATORS
- o RCS THRUSTERS

HERITAGE

- o ONE NEW DEVELOPMENT
 - I/O UNIT
(SIMILAR TO UNIT ON CLASSIFIED PROGRAM)
- o ALL OTHER HARDWARE SPACE QUALIFIED
 - TITAN
 - PEACEKEEPER
 - IUS
 - TOS (BY FEB 1986)

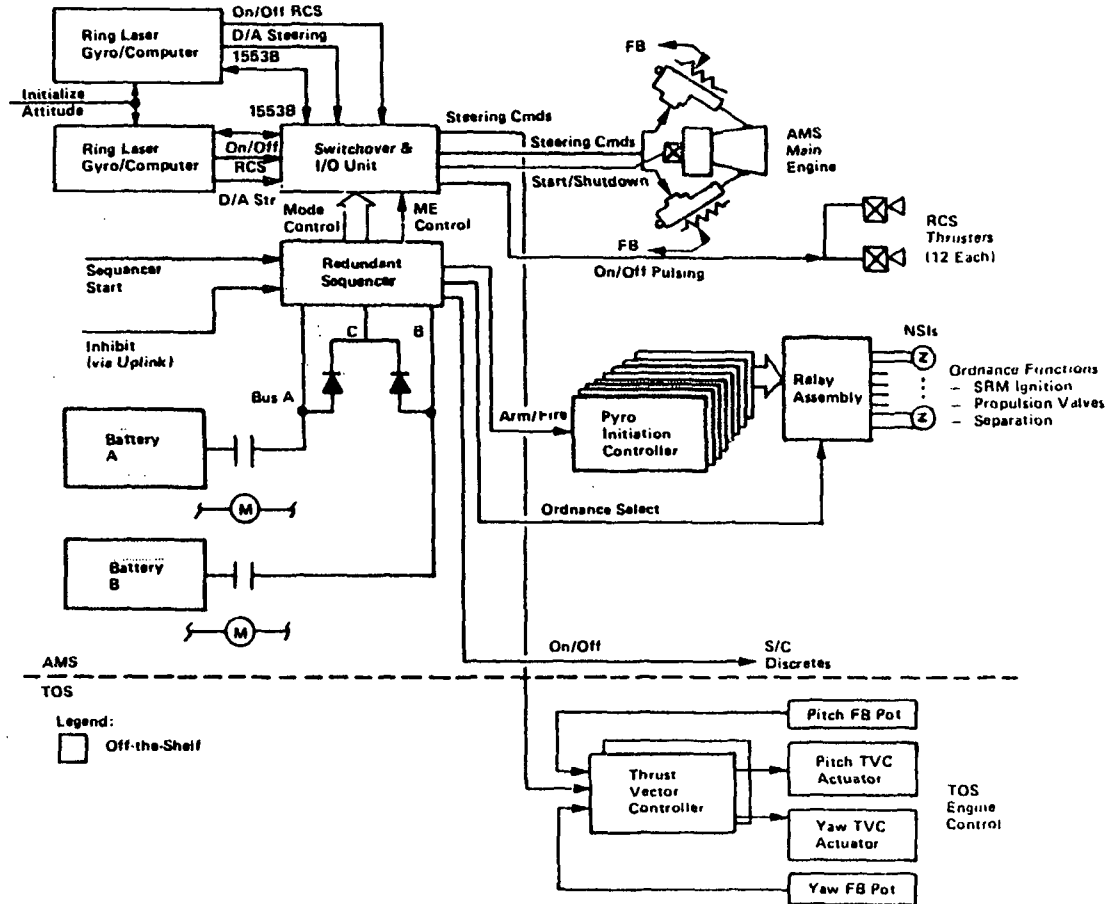

NO CHANGES FOR TDRS

MAIN PROPULSION IS CONVENTIONAL PRESSURE-FED BI-PROPELLANT

The TOS/AMS design is based on conservative engineering and proven solid and liquid propulsion technologies. Major propulsion elements of our TOS/AMS include the TOS SRM, AMS main propulsion and RCS. Perigee impulse is provided by the TOS SRM, apogee impulse is provided by the AMS main propulsion system (MPS), and torque is provided for attitude control of both stages by the reaction control system. In combination, these systems support a cost-effective approach for TDRS deployment that minimizes schedule and mission risk by making maximum practical use of flight-qualified components. The MPS is a proven storable bipropellant design derived from Martin Marietta's unique, long-term experience in development and operation of liquid rocket propulsion stages. This experience includes the pioneering Titan II and extends through Mariner and Viking to the currently active Titan III, Transtage, and Mark II propulsion module (PM). Our proposed system is illustrated schematically in the facing page. It is a conventional pressure fed system using nitrogen tetroxide (NTO) and monomethyl hydrazine (MMH) as propellants.

The thrust level for the MPS was selected to provide maximum practical payload capability for TOS/AMS to GSO. The Rocketdyne 2650-lbf engine delivers 315 seconds specific impulse and provides the maximum GSO capability possible using demonstrated engine designs based on flight-qualified hardware. This thrust level also provides significant interplanetary capability.

The intent of component selection for the propulsion system was to use all qualified and flight-proven hardware. This effort was largely successful except for the propellant tank and main engine, which require only limited, low-risk changes.

Removal of the current propellant management device (PMD) from the L-SAT tank does not affect the structural qualification status but does affect the flow-related qualification status. The addition of an anti-vortex device (to reduce unusable fuel) will require some qualification retesting at the component (PMD) level only. It will be welded into the tank using the standard procedures so that the qualification status of the basic tank will not be altered. Finally, a flow test will be conducted to verify the ability of the tank/PMD to satisfy engine flow demands. This test will use a rigorous qualification test program in accordance with Martin Marietta test procedures, Manual M-67-45. Testing will be accomplished at existing Denver Aerospace facilities.

Changes to the Rocketdyne Peacekeeper engine are low risk, but require a delta qualification program. To meet the AMS burn time requirements, the combustion chamber liner must be changes from the current high-density silica to silicon carbide in a phenolic resin. This change has been successfully demonstrated in two Rocketdyne sponsored tests.

MAIN PROPULSION IS CONVENTIONAL PRESSURE-FED BI-PROPELLANT

Osc

MARTIN MARIETTA

REDUNDANCY

- o PRESSURE REGULATOR
- o CHECK VALVES
- o PYRO VALVES (INITIATORS)

HERITAGE

- o TWO MOD COMPONENTS
 - PK ENGINE
 - L-SAT TANK
- o ALL OTHER HARDWARE DEVELOPED
 - SHUTTLE CENTAUR
 - PM MARK II
 - VIKING
 - SHUTTLE OMS
 - PEACEKEEPER
 - MARINER

NO CHANGES FOR TDRS

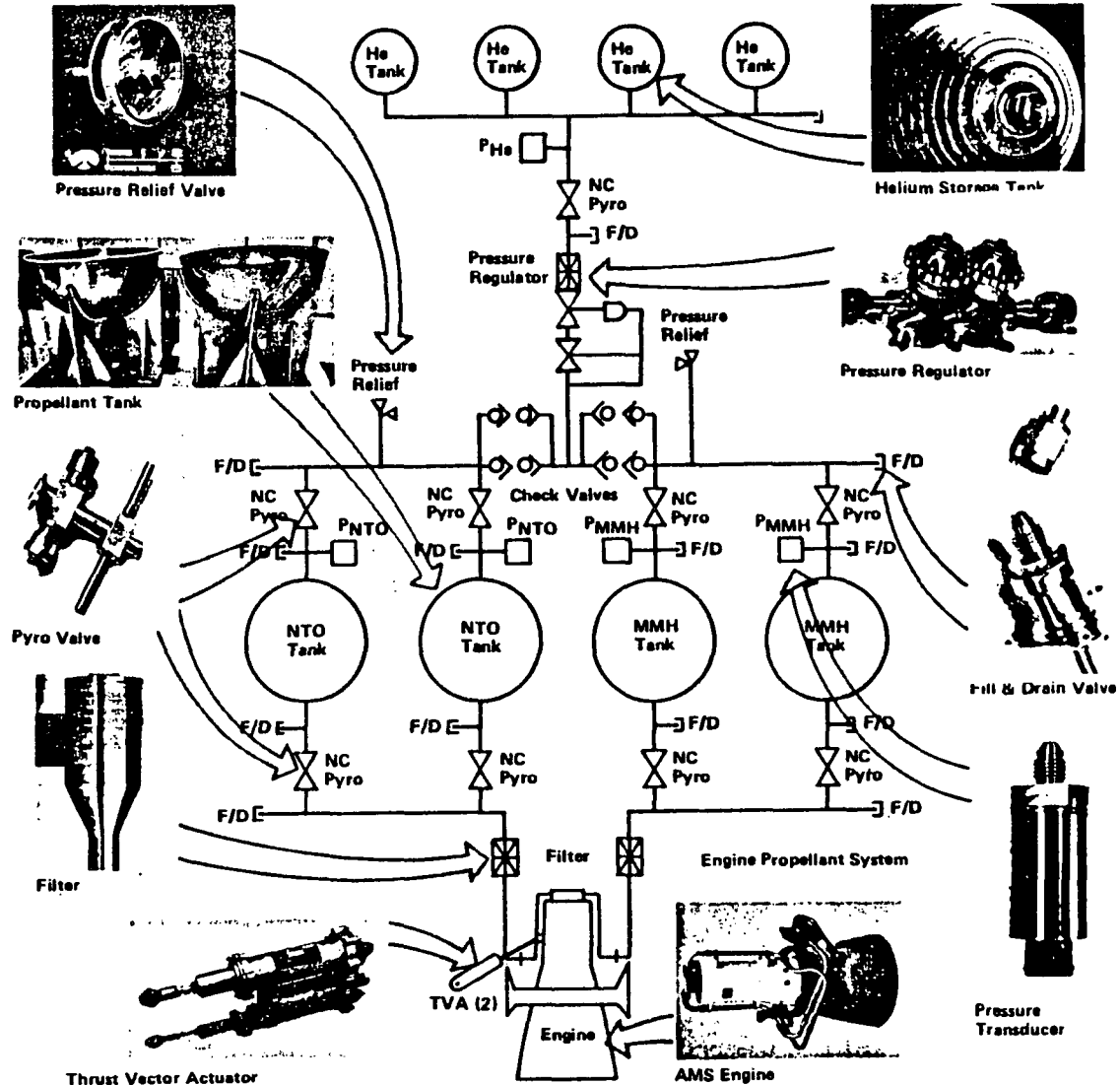

RCS PROPULSION IS ALL FLIGHT PROVEN

Our system is illustrated in the facing page. Our decision to use independent RCS and main propulsion systems is based on a desire to minimize technical and schedule risks while providing mission flexibility and the highest practical system reliability. We are able to use RCS thrust to settle main propellants before each burn and thus simplify propellant management requirements for the main tanks. Our design is a conservative one that combines high reliability and low cost by using hydrazine monopropellant with blowdown nitrogen gas pressurization. All components were selected from existing flight-qualified hardware.

Six rocket engine modules (REM), each containing two engines, provide redundant, three-axis control and velocity increment capability. Aft-pointing thrusters for pitch and yaw control minimize the risk of payload contamination. Each propellant tank holds 60 lb of usable hydrazine, a 25% margin over TDRS requirements. Tanks and lines are heated to prevent propellant freezing and wrapped with MLI to minimize heater power requirements. Thruster valves and chambers also are heated to prevent catalyst bed damage resulting from cold starts.

The system contains three welded assemblies: the propellant tanks, propellant manifold, and REMs. This arrangement allows assembly and checkout at the factory and replacement of assemblies at the launch site should it be required.

STS safety requirements are met without compromise. To preclude adiabatic detonation and waterhammer pressure surges, the propellant manifold is filled through an orificed bleed line before opening the main isolation valve. All ordnance is two-fault tolerant, and three independent seals are provided between the propellant and the orbiter bay. The propellant tank is designed to fracture mechanics criteria and has a safety factor of four.

The selected RCS components are all flight proven. The filter, propellant tank, and REM provide a significant performance margin. Each REM provides a thrust and specific impulse of 29.7 ± 2 lbf and a 229-s minimum at 380 psia, and $9.4 \pm 0.6\%$ lbf and 220-s minimum at 100 psia.

RCS PROPULSION IS ALL FLIGHT PROVEN

QSC

MARTIN MARIETTA

REDUNDANCY

- 0 THRUSTERS
- 0 THRUSTER VALVES
- 0 PYRO VALVES (INITIATORS)

HERITAGE

- 0 GPS
- 0 SATCOM
- 0 PM MARK II
- 0 VIKING
- 0 IUS

NO CHANGES
FOR TDRS

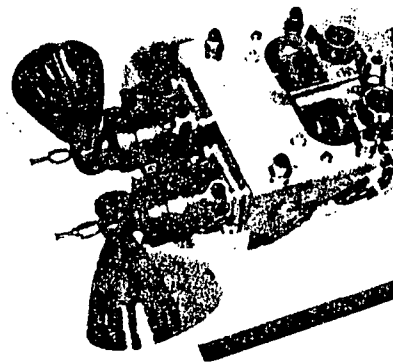
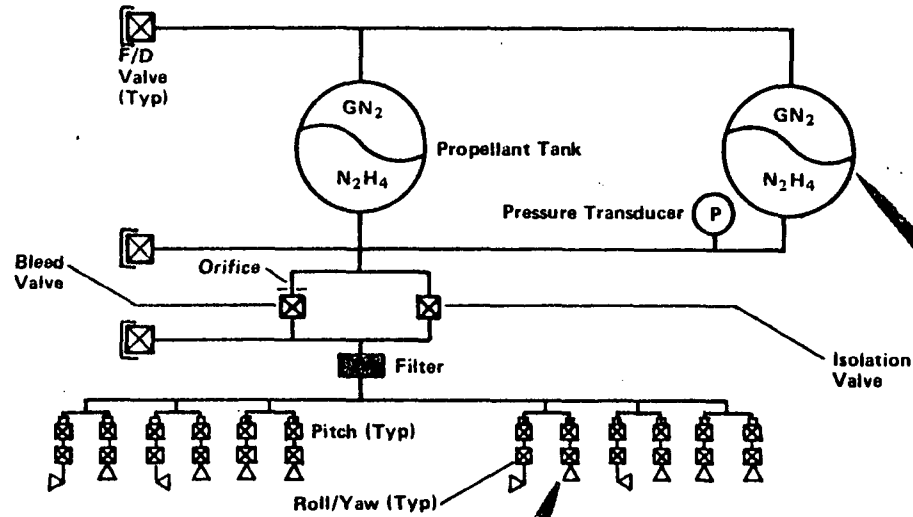

Mfg: Hamilton Standards
2-Engine Rem



Propellant Tank

01126-27-WP

TOS/AMS/TDRS STUDY SCHEDULE

The facing page chart presents the study schedule for the application of TOS/AMS to TDRS E&F. The specific study tasks are identified in the left column with a summary of the results presented in the right column.

All study tasks were completed and the results substantiated that the TOS/AMS can meet all TDRS requirements without impact or change to the basic TDRS Spacecraft. The performance, accuracy, maneuvers, and operations are met with the basic TOS/AMS. Loads and dynamics are satisfied by use of the IUS cradle, TDRS unique kits were defined to provide for power and telemetry and command requirements. The IUS cradle, associated SSP in the orbiter and ground handling equipment are assumed GFE from the Air Force through NASA. We assessed the procurement of a new cradle from Boeing, however, the cost was prohibitive particularly when contractor G&A, overhead and fee by both Martin Marietta and OSC were added. If procurement were required it appears more cost effective for the government to procure it directly from Boeing.

TOS/AMS/TDRS STUDY SCHEDULE		RFP TASK NO.	1984						
			J	F	M	A	M	J	J
1	MAJOR MILESTONES		INITIAL TDRS DATA		MID TERM REVIEW		FINAL REVIEW		
2			▲ TDRS DATA		▲		▲		
3			ATP ▲		▲		▲		
4			▲		▲		▲		
5			▲		▲		▲		
6	PERF ASSESSMENT	3.1.1	-PERFORMANCE GREATER THAN 5000 LBS ESTABLISHED						
7			-FPR, WEIGHTS, MASS PROPERTIES DEVELOPED						
8	ACCURACY ASSESSMENT	3.1.2	-ALTERNATE GUIDANCE SYS EVALUATED						
9			-BASELINE RL6 YIELDS 75 LBS HYDRAZINE FOR CORRECTION						
10	STRUCTURE ANALYSIS	3.1.3	-TDRS DYNAMICS REQ'S SATISFIED FOR LIFT-OFF & LANDING						
11	I/F ADAPT DEFINITION	3.1.4	-STRUCTURAL I/F DEFINED						
12			-TDRS KITS PACKAGED INSIDE AMS						
13	THERMAL, POWER ANALYSIS, KIT IDENT	3.1.5	-TDRS THERMAL REQ'S MET						
14			-TELEMETRY & COMMAND, & POWER KITS DEFINED						
15	ATT. CONTROL ANALYSIS	3.1.6	-CONTROL AUTHORITY VERIFIED						
16			-MANEUVER & POINTING REQ'S MET						
17	IDENT SPECIAL SERVICES, SUPPORTING ITEMS	3.1.7	-REQ'S EVALUATED & SATISFIED						
18	DEV PROGRAM SCHEDULES	3.1.10	-LONG LEAD IDENTIFIED						
19			-CRITICAL PATH ESTABLISHED						
20			-SUMMARY SCHEDULES COMPLETE FOR MID 87 LAUNCH						
21	ORBITER SAFETY REQUIREMENTS	3.1.11	-ORB SAFETY EVALUATED						
22			-PHASE ZERO FOR JSC & KSC COMPLETE						
23	ENVIRONMENTAL EFFECTS	3.1.12	-NO SIGNIFICANT ENVIRONMENTAL ISSUES IDENTIFIED						
24	OPERATIONS ANALYSIS	3.1.13	-TDRS HAS NO MAJOR IMPACT ON GND & FLT OPS						
25			-ASE TUS CRADLE, GSE TUS CRADLE & KIT C/O						
26	ROM EST-TDRS UNIQUE	3.1.8	-ROM COST DEVELOPED FOR KITS						
27	ROM EST-TWO TOS/AMS VEH & INTEGRATION	3.1.9	-ROM COST DEVELOPED FOR TWO VEHICLES						
28	BRIEFINGS & STUDY REPORTS	3.2 & 3.3	-ORIENTATION MID-TERM & FINAL COMPLETE						

Prepared by: D. IGOU, JR.
Program Manager: W. PIPES

Date: 05/10/84 PIPES

MARLIN/MARTELA

CONTRACT SCHEDULE ◁ PLAN ⇨ ACTUAL → PREVIOUS EMR ◇

TOS/AMS PROGRAM PLAN AND SCHEDULES - TASK 3.1.10

The TOS/AMS program schedules and logic network have been developed to reflect the major program elements and flow of effort from authority to proceed (ATP) through launch. For the protoflight concept the production hardware is used to support the development program and subsequent refurbishment for flight. From the logic network and associated critical path the overall schedule of 34 mo. for procurement of one TOS/AMS that is used for system qualification, refurbished and launched can be met. Within the 34 mo. schedule there is 2 mo of slack. The slack periods are 1 month during refurbishment in Denver and 1 month during launch processing at KSC. The schedule is based on a single shift in Denver and at KSC a single shift initially with multiple shifts during the final 18 days.

Long lead procurement has also been reviewed and evaluated based on past experience. The facing page chart summarizes this data and the "critical" long lead where the supplier must have authorization to process within two months after program ATP in order to support internal milestones on the critical path. These components include the main propellant tanks for assembly, the helium pressure tanks to support the propulsion cold flow test and the three telemetry components to support system test and checkout prior to integration.

TOS/AMS PROGRAM PLAN AND SCHEDULES - TASK 3.1.10



- 0 LOGIC NETWORK DEVELOPED
- 0 CRITICAL PATH DEFINED FOR TDRS-E
 - 34 MONTH SCHEDULE WITH TWO MONTH SLACK
 - SCHEDULE BASED ON SINGLE SHIFT IN DENVER
 - KSC SINGLE SHIFT WITH MULTIPLE SHIFTS DURING FINAL 18 DAYS
- 0 LONG LEAD PROCUREMENT IDENTIFIED AND EVALUATED

<u>ITEM</u>	<u>VENDOR QUOTE</u>	<u>PAST EXPERIENCE</u>
AMS MAIN ENGINE	21 MONTHS	20-25 MONTHS
TOS SRM-1	19 MONTHS	--
REMS	17 MONTHS	14-18 MONTHS
** MAIN PROPELLANT TANK	17 MONTHS	15-18 MONTHS
RCS PROPELLANT TANK	14 MONTHS	10-14 MONTHS
** MAIN PROPULSION COMPONENTS (HE TANK)	13 MONTHS	5-14 MONTHS
SUPERZIP	14 MONTHS	--
** AVIONICS COMPONENTS (ENCODER, TRANSPONDER, AMPLIFIER)		16 MONTHS
INERT SRM	GSE	--
RING-LASER GYROS	14 MONTHS*	12-15 MONTHS
* THIS IS THE ANTICIPATED LEAD TIME FOR THE PRESENT TOS PROGRAM.		
** SUPPLIER ATP WITHIN TWO MONTHS AFTER PROGRAM ATP.		

TOS/AMS/TDRS LOGIC SCHEDULE

The program critical path reflects the use of production hardware to support subsystem and system tests planned in the development program.

The critical path for the TOS/AMS program is initiated with the preliminary design of structures and flows through final structures design into the production process. After production planning, we will go through detail fabrication to the start of AMS structure subassembly, and then through structure final assembly. At completion of structure assembly, we are ready to start the structures test.

The critical path continues through completion of structure proof load and modal survey testing to the start of integration and testing the full complement of subsystem equipment. The three months allocated to this effort break down to : (1) one month for propulsion subsystem installation and leak test; (2) one month for avionics, electrical, and kit installation and test; and (3) one month for thermal-blanket fit and closeout activities. The schedule allows for a fix and retest on 10% of the propulsion system mechanical joints. At completion of integration and assembly, the path continues to system tests.

After completion of systems test, the final portion of the critical path enters the TOS/AMS hardware refurbishment and continues through to the pack and ship activity for shipment to the launchsite. One month slack is identified prior to shipment. The path then flows through TOS/AMS launch processing and spacecraft launch processing, which culminates in the launch of the TDRS-E spacecraft. Between completion of the TOS/AMS launch processing and start of the spacecraft launch processing, a month's margin is provided for schedule contingencies.

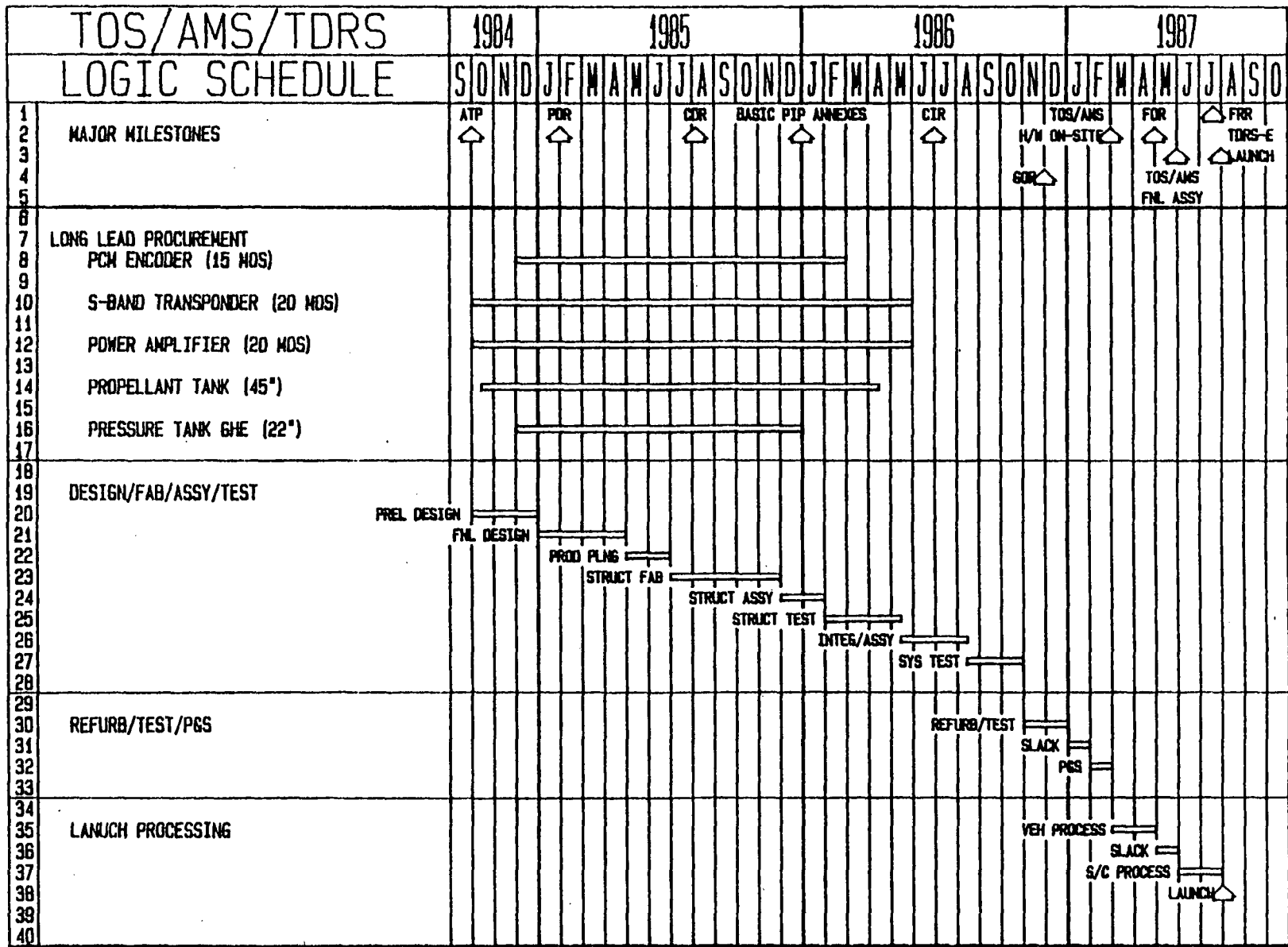

Contract Number: 20XXXX
 Program Manager: W. PIPES

Prepared by: D. IGOU, JR.
 Date: 05/25/84 NEWLOGIC



TOS/AMS/TDRS EARLY LAUNCH SCHEDULE

The TOS/AMS production schedule on the facing page shows the schedule plan for build and launch of two TDRS-configured vehicles. The plan incorporates the schedule with identified time spans for build and launch of the second unit prior to the first. The time spans for structure assembly and subsequent build activities reflect the risk-mitigation constraint from completion of the development programs structural testing. With early identification of two-vehicle production program, we could structure a launch capability 3 months earlier with nominal increase of risk. This is accomplished by conducting the system level tests on the first unit while the second is being built and prepared for launch. During refurbishment of the first unit following system test the second is sent to the launch site for processing.

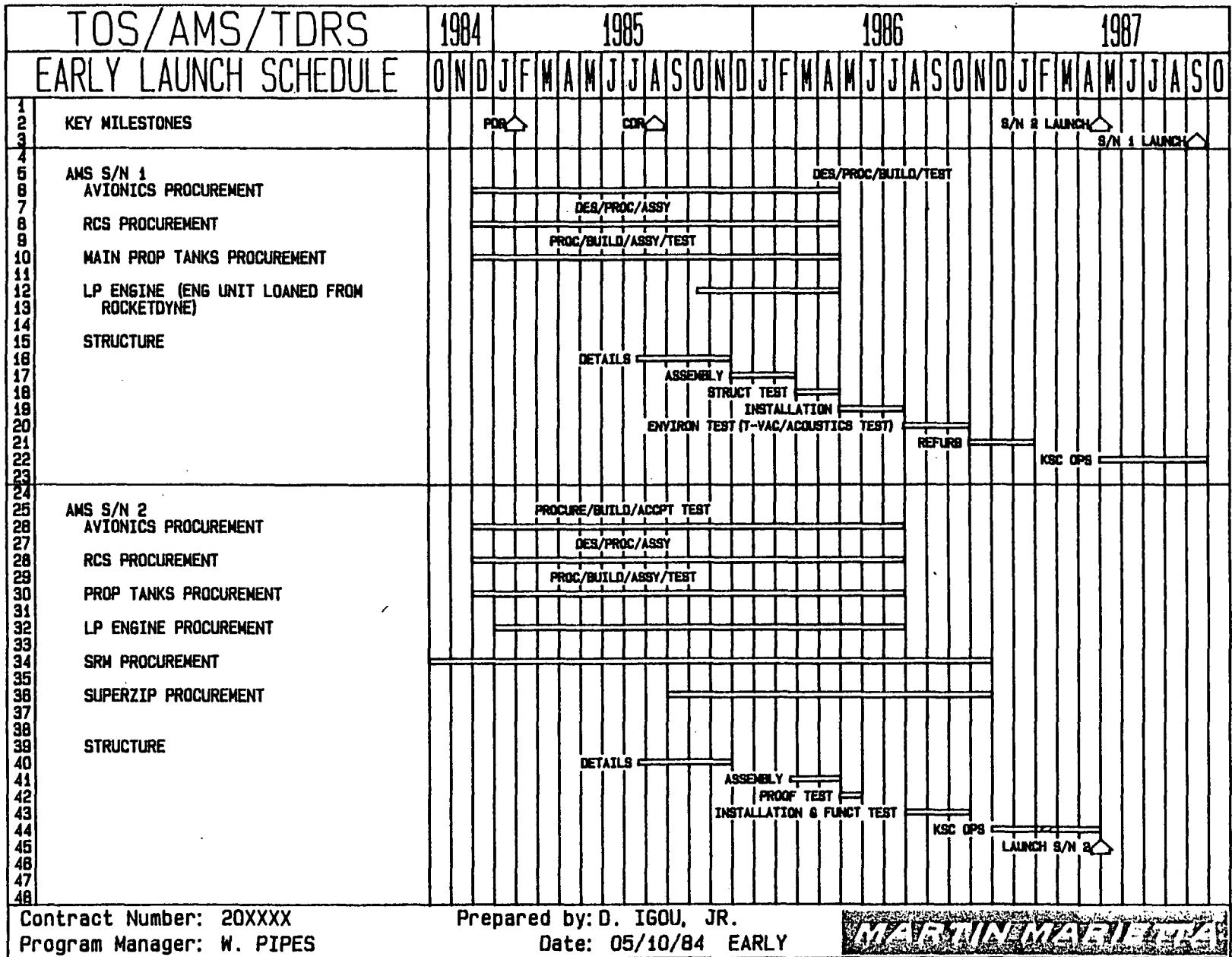

Contract Number: 20XXXX
 Program Manager: W. PIPES

Prepared by: D. IGOU, JR.
 Date: 05/10/84 EARLY



CONTRACT SCHEDULE ◁ PLAN ≡ ▴ ACTUAL → PREVIOUS EMR ◇

TECHNICAL RISK SUMMARY

For the TOS/AMS one new component, the I/O Unit, requires development. The avionics I/O Unit is similar to a unit Martin Marietta developed on a classified program. In addition, extensive experience will be gained on TOS through the design and development of the Value Drive Amplifier that interfaces with the majority vote sequencer, RLG and RCS thrusters.

The AMS main engine from Peacekeeper has a heritage of 36 development engines and 4 successful missile flights. The increased chamber duration for AMS from 200 to 865 seconds has already been demonstrated in two successful tests by Rocketdyne of 1000 and 725 seconds. The columbium nozzle extension to 72:1 is state of-the-art and flight qualified on the Japanese N-11 engine, Shuttle OMS, Delta and Transtage.

The L-SAT tank modification is actually a simplification of the present design. The internal barrier and zero-g acquisition system are removed and a simple screen is placed over the outlet to prevent gas migration into the feedline.

The remaining components are or will be qualified prior to the AMS need dates. Fifteen come from the TOS program of which only 3 are new or modified (RLG, MVS and PIC Box). The remaining components are all flight proven on other programs.

TECHNICAL RISK SUMMARY

OSC

MARTIN MARIETTA

ONE NEW COMPONENT DEVELOPMENT

- 0 AVIONICS I/O UNIT
 - o SIMILAR TO UNIT ON CLASSIFIED PROGRAM
 - o EXPERIENCE GAINED FROM TOS VDA DESIGN

TWO MODIFIED COMPONENTS

- 0 AMS MAIN ENGINE FOR EXTENDED DURATION
- 0 L-SAT PROPELLANT TANK WITH SIMPLIFIED PMD

ALL OTHER COMPONENTS ARE OR WILL BE QUALIFIED PRIOR TO AMS NEED DATES

- 0 TOS COMPONENTS ARE 15 OF WHICH ONLY THREE ARE NEW OR MODIFIED
 - o RLG
 - o MVS
 - o PIC BOX
- 0 COMPONENTS FROM OTHER FLIGHT PROGRAMS ARE 21

TOS/AMS FOR TDRS PROVIDES NUMEROUS BENEFITS TO NASA

The following list identifies the principal benefits to NASA of the TOS/AMS for TDRS launches:

- 1) TDRS Mission Assurance - Martin Marietta's unmatched record of launch vehicle success, coupled with NASA's past and continuing technical oversight of the stage development, assures successful delivery of TDRS.
- 2) No change to the TDRS Spacecraft - The TOS/AMS is designed to provide TDRS with the interfaces and environments for which it was designed--no TDRS spacecraft changes will be introduced.
- 3) Excellent Performance Margin - The propellant capacity of the AMS provides TDRS with a growth potential of up to 800 lb.
- 4) Excellent Injection Accuracy - The TOS/AMS provides all the orbit insertion accuracy required for TDRS missions through its highly accurate redundant ring laser gyro (RLG) system and accelerometer-governed shutoff of the liquid propellant second stage.
- 5) Demonstrated Ride Characteristics - TDRS was designed for the load environment provided by the IUS airborne support equipment. Use of the IUS load-alleviated cradle avoids the cost and potential risk of adapting TDRS to another launch load environment.
- 6) Schedule Flexibility for Callup Launch of TDRS - The solid/storable propellant systems of the TOS/AMS are readily stored, and the laser gyro guidance system features extended retention of calibration to provide accurate performance on a short-term callup.
- 7) Early Availability for TDRS-E - Because early launch of TDRS-E may be required, we offer a production option that permits launch as early as April 1987.
- 8) Low-Risk Development Program - Extensive use of existing flight-proven systems and a thorough understanding of the development task gives Martin Marietta the confidence to undertake TOS/AMS development on a fixed price basis.

TOS/AMS FOR TDRS PROVIDES NUMEROUS BENEFITS TO NASA

Osc

MARTIN MARIETTA

1. TDRS MISSION ASSURANCE - MARTIN MARIETTA RECORD OF SUCCESS AND NASA INVOLVEMENT
2. NO CHANGE TO TDRS - TOS/AMS BASIC DESIGN AND USE OF KITS
3. PERFORMANCE MARGIN - 800 LB EXCESS CAPABILITY
4. INJECTION ACCURACY - REDUNDANT RLG AND LIQUID PROP. PROVIDES VELOCITY SHUTDOWN
5. DEMONSTRATED SOFT RIDE - USE OF IUS CRADLE (EVALUATING DIRECT MOUNT)
6. SCHEDULE FLEXIBILITY FOR CALLUP - SOLID/STORABLE PROP. AND RLG EXTENDED CAL.
7. EARLY AVAILABILITY FOR TDRS E - PRODUCTION OPTION FOR EARLY 1987 LAUNCH
8. LOW-RISK DEVELOPMENT PROGRAM - FLIGHT PROVEN SYSTEMS



OSC

MARTIN MARIETTA

2.0 TDRS REQUIREMENTS AND SYSTEM DESIGN

TDRS UNIQUE REQUIREMENTS EVOLUTION

Using the Contract Statement of Work, the IUS/TDRS Interface Control Document (ICD), the TDRS Payload Integration Plan (PIP) and a series of meetings with NASA, the TDRS unique requirements imposed upon the TOS/AMS were defined. The definition of these requirements involved using the basic TOS/AMS Contract End Item (CEI) specification and preparing an Addendum 1 CEI Specification for TDRS. Also, a TOS/AMS TDRS Interface Control Document (ICD) was prepared.

QSC

MARTIN MARIETTA

TDRS UNIQUE REQUIREMENTS EVOLUTION

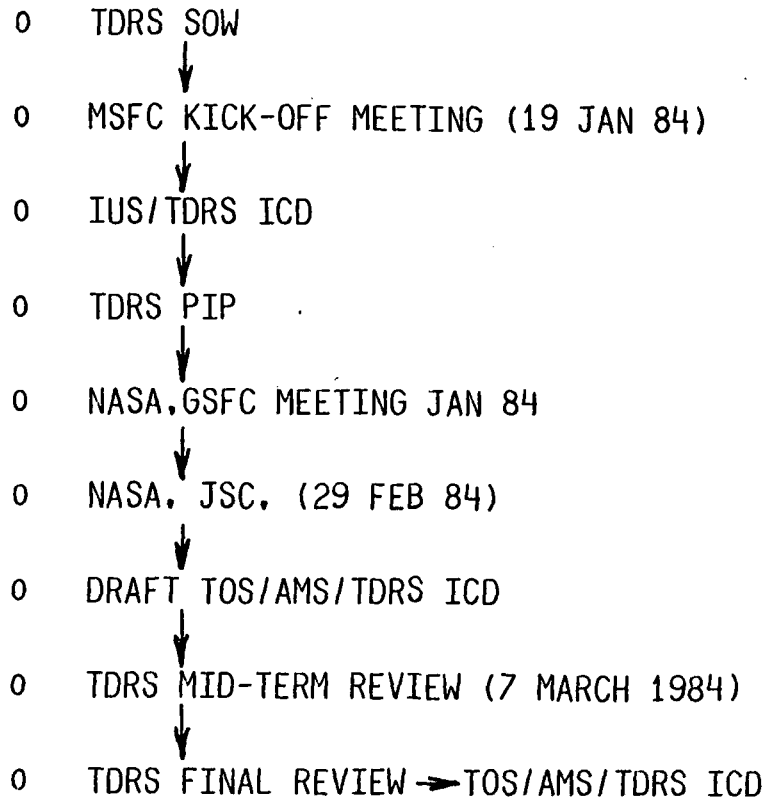

->ADDENDUM 1 TO CEI SPECIFICATION FOR TDRS.

TOS/AMS TDRS/STS REQUIREMENTS DOCUMENTATION FLOW

As shown, the TOS/AMS TDRS/STS Requirements Documentation flow encompasses many documents in the evolution of the necessary TOS/AMS TDRS documents for interfacing with the STS/orbiter. The generic PIP (JSC-14029) and the generic NASA JSC requirements (ICD-A-19001) provide the basis for the STS requirements. Also, the generic TOS/AMS CEI Specifications and ICD's contribute to the TDRS related CEI and ICD for TOS/AMS.

TOS/AMS TDRS/STS REQUIREMENTS DOCUMENTATION FLOW



MARTIN MARIETTA

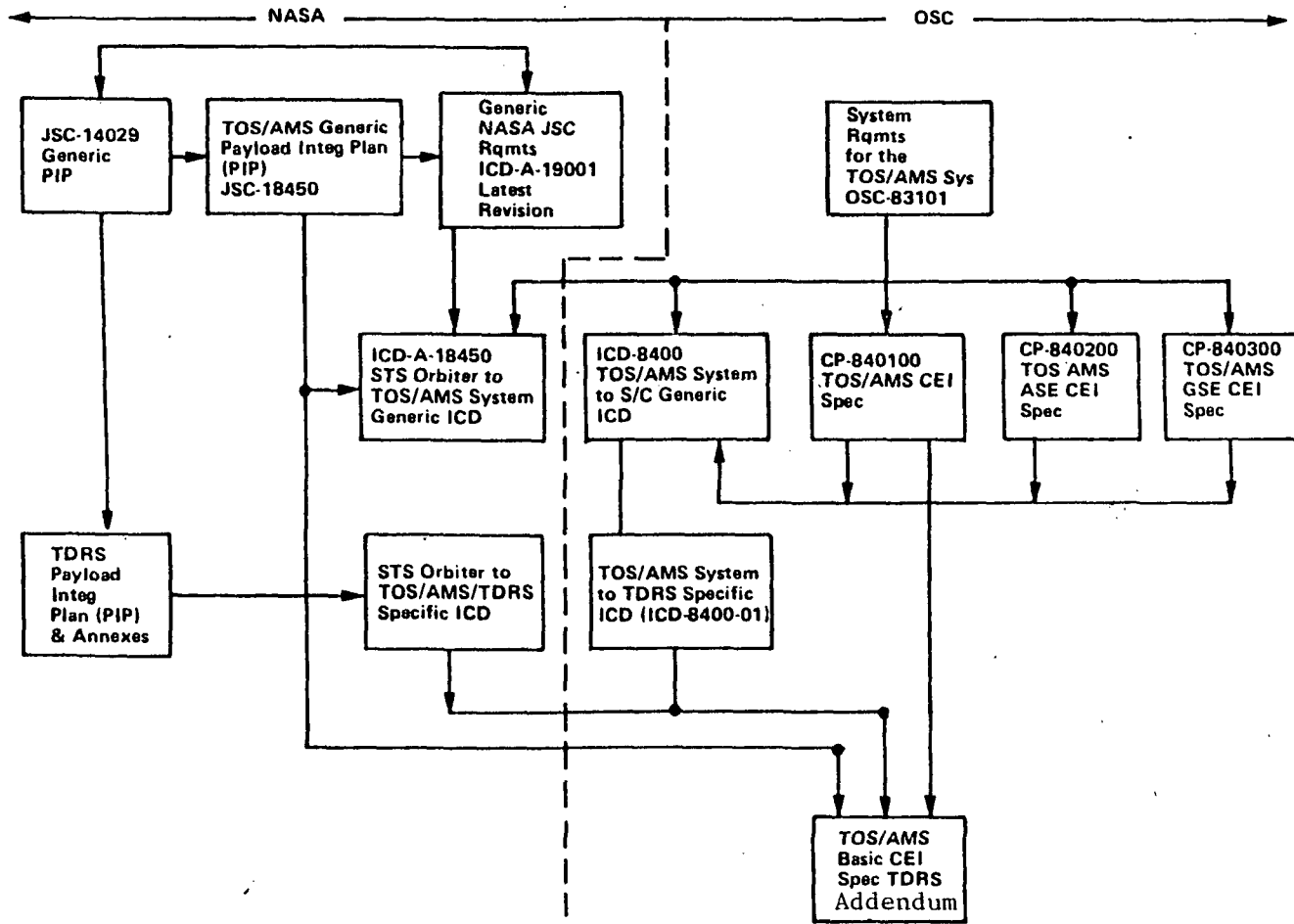

BASIC TOS/AMS REQUIREMENTS

The basic TOS/AMS requirements easily satisfy the TDRS unique requirements. The basic TOS/AMS is compatible with the STS while providing \geq 6000 lb of payload to GEO (5,000 lb required for TDRS). The telemetry function is part of the basic vehicle capability, but can be removed and replaced with a telemetry and command kit for the TDRS mission. Also, a power kit is available to provide the dedicated power to TDRS.

BASIC TOS/AMS REQUIREMENTS

QSC

MARTIN MARIETTA

- STS COMPATIBILITY
- PERFORMANCE \geq 6000 LB PAYLOAD TO GEO
- SRM-1 PROPULSION FOR TOS WITH SUPPORT STRUCTURE
- AMS COUPLED TO TOS WITH ASM CONICAL/SKIN STRINGER (8-BOLT SEPARATION)
- SPACECRAFT CANTILEVERED FROM AMS
- AMS PROPULSION - BIPROPELLANT LIQUID
- MONOPROPELLANT RCS MOUNTED ON AMS
- AVIONICS WITH ADDED 3-AXIS ATTITUDE POINT REQUIREMENTS & MANEUVER-CAPABILITY FOR RCS, SRM & BIPROPELLANT ENGINE IN AMS
- TELEMETRY (CAN BE REMOVED)

AVAILABLE KITS

- POWER
- TELEMETRY & COMMAND

0325L/PPP/2

TDRS REQUIREMENTS SUMMARY - STRUCTURAL/MECHANICAL

The following pages summarize the detail unique TDRS requirements imposed upon TOS/AMS involving:

- Structural/Mechanical
- Thermal
- Contamination
- Power
- Ordnance Firing
- Telemetry
- Communications
- Flight Operations

The basic TOS/AMS design satisfies all of the TDRS Structural/Mechanical requirements. The eight attachment points are the same as for IUS, interfacing with the TDRS adapter. A dynamic and loads analysis was conducted using the IUS cradles for the TOS/AMS with TDRS and indicated excellent performance.



MARTIN MARIETTA

TDRS REQUIREMENTS SUMMARY - STRUCTURAL/MECHANICAL

<u>REQUIREMENTS</u>	<u>COMPLIANCE</u> BASIC DESIGN KIT	<u>REMARKS</u>
MECHANICAL INTERFACE SHALL CONSIST OF THE AMS FORWARD FRAME JOINING TO THE SPACECRAFT ADAPTER AT THE CURRENT EIGHT ATTACH POINTS.	X	SAME AS IUS
TOS/AMS & ASE SHALL SUPPORT THE CANTILEVERED TDRS, WEIGHING 5000 LB.	X	USE OF THE IUS LOAD ALLEVIATED CRADLE
TOS/AMS STRUCTURE DESIGN SHALL BE BASED ON COUPLED ANALYSES OF STS DYNAMIC & QUASI-STATIC LOADS CONDITIONS FOR LAUNCH, FLIGHT, LANDING AND ABORT.	X	PERFORMED BY ANALYSIS USING THE TOS/AMS, TDRS & ORBITER MATH MODELS. VERIFIED AT THE 20 CRITICAL NODE POINTS.
THE TOS/AMS/TDRS SHALL WITHSTAND THE ORBITER CARGO BAY COMBINED INTERNAL ACOUSTIC ENVIRONMENT.	X	TOS/AMS BASIC DESIGN
THE AMS/TDRS INTERFACE SHALL WITHSTAND THE MAXIMUM PREDICTED ACCELERATION, SHOCK & VIBRATION ENVIRONMENTS.	X	TOS/AMS BASIC DESIGN.

0325L/PPP/3

TDRS REQUIREMENTS SUMMARY - THERMAL

The basic TOS/AMS design satisfies all of the TDRS thermal requirements. The roll rate of 3 ± 0.3 degrees/second is provided by the basic attitude control system. These maneuvers are initiated no later than 16 minutes following deployment. The RCS thrusters are the same as those used for the IUS.

TDRS REQUIREMENTS SUMMARY - THERMAL

QSC

MARTIN MARIETTA

<u>REQUIREMENTS</u>	<u>COMPLIANCE</u> BASIC DESIGN KIT	<u>REMARKS</u>
THERMAL CONTROL ATTITUDE FOLLOWING SEPARATION FROM THE ORBITER SHALL BE TDRS-Z AXIS TOWARD THE SUN WITHIN 40 ± 5 DEGREES OF THE LOCAL SUNLINE. ROLL RATE SHALL BE 3 ± 0.3 DEG/S.	X	BASIC ATTITUDE CONTROL SYSTEM DESIGN; FLIGHT DESIGN PROFILE. (RCS THRUSTERS CONFIGURATION SAME AS IUS.)
THERMAL MANEUVERS SHALL BE INITIATED NO LATER THAN 16 MINUTES FOLLOWING DEPLOYMENT & CONTINUED (EXCEPT FOR TELEMETRY DIPOUTS) UNTIL THE MANEUVER WHICH ORIENTS AMS FOR CIRCULARIZATION BURN.	X	BASIC ATTITUDE CONTROL SYSTEM DESIGN; FLIGHT DESIGN PROFILE.
TOS/AMS SHALL PROVIDE A THERMAL BLANKET ACROSS THE TOS/AMS & TDRS INTERFACE & SHALL BE GROUNDED TO THE TOS/AMS STRUCTURE.	X	MLI THERMAL BLANKET PROVIDED.

TDRS REQUIREMENTS SUMMARY - THERMAL (Cont'd)

As previously indicated, the basic TOS/AMS design satisfies all of the TDRS thermal requirements. During the communication dipouts, the basic attitude control system constraints the sun from impinging on the TDRS S-5 Spacecraft panel. A thermal analysis and RCS utilization analysis was conducted for TOS/AMS with TDRS and indicated excellent performance with the basic design approach.

TDRS REQUIREMENT SUMMARY - THERMAL (CONT)

QSC

MARTIN MARIETTA

<u>REQUIREMENTS</u>	<u>COMPLIANCE</u>	<u>REMARKS</u>
TOS/AMS SHALL MAINTAIN ATTITUDE FOLLOWING DEPLOYMENT FROM THE ORBITER & CONDUCT MANEUVERS DURING PARKING & TRANSFER ORBIT COAST TO SATISFY TDRS THERMAL REQUIREMENTS.	X BASIC DESIGN KIT	BASIC ATTITUDE CONTROL SYSTEM DESIGN; FLIGHT DESIGN PROFILE.
DURING COMMUNICATION DIPOUTS THE SUN SHALL BE CONSTRAINED FROM IMPINGING ON THE TDRS-DESIGNATED S-5 SPACECRAFT PANEL.	X	BASIC ATTITUDE CONTROL DESIGN; FLIGHT DESIGN PROFILE.
THERE SHALL BE NO SOLAR ECLIPSE OF THE TDRS OF MORE THAN 30 MINUTES ACCUMULATIVE DURATION DURING THE TRANSFER ORBIT & NO ECLIPSE SHALL OCCUR IN THE LAST 1.5 HOURS BEFORE TDRS SEPARATION FROM THE AMS.	X	BASIC ATTITUDE CONTROL SYSTEM DESIGN; FLIGHT DESIGN PROFILE. THERMAL ANALYSES CONDUCTED & RCS UTILIZATION ANALYZED WITH A DETAILED MISSION PROFILE.

TDRS REQUIREMENTS SUMMARY - CONTAMINATION

The basic TOS/AMS design minimizes contamination for the TDRS mission. The selection of materials and components involved the consideration for corrosion wear products, shedding and flaking. The TOS/AMS main propulsion system and Reaction Control System (RCS) does not impinge or reflect directly on the TDRS Spacecraft. The Contamination Control Plan and analysis will ensure that TOS/AMS contamination effects will not impact the operation of the TDRS spacecraft.

TDRS REQUIREMENTS SUMMARY - CONTAMINATION

OSC

MARTIN MARIETTA

REQUIREMENTS

COMPLIANCE
BASIC
DESIGN KIT

REMARKS

CROSS CONTAMINATION BETWEEN THE AMS & TDRS SHALL BE CONTROLLED TO MINIMIZE OUTGASSING.

X

SELECTION OF MATERIALS & COMPONENTS INCLUDING CONSIDERATION OF CORROSION, WEAR PRODUCTS, SHEDDING, & FLAKING.

TOS/AMS MAIN PROPULSION SYSTEM & REACTION CONTROL SYSTEM THRUSTER EXHAUST SHALL NOT IMPINGE DIRECTLY OR BE REFLECTED UPON TDRS DURING ANY MODE OF RCS THRUSTER OF MAIN ENGINE OPERATION.

X

BASIC PROPULSION SYSTEM DESIGN; FLIGHT DESIGN PROFILE. SAME RCS THRUSTERS & ORIENTATION AS IUS. SAME STAGE I MOTOR AS IUS.

TOS/AMS SYSTEM SHALL NOT AFFECT THE PERFORMANCE OF CRITICAL TDRS COMPONENTS DUE TO CONTAMINATION FROM PARTICULATE & MOLECULAR CONTAMINANTS DURING GROUND, LAUNCH & IN ORBIT OPERATIONS.

X

CONTAMINATION CONTROL PLAN & ANALYSIS.

NO MATERIALS HAVING A MAGNETIC PERMEABILITY OF 10 OR GREATER SHALL BE USED AT AMS/TDRS FAYING SURFACES THAT COULD GENERATE PARTICULATES DURING NORMAL MISSION OPERATIONS.

X

SELECTION OF MATERIALS. USE OF SHUTTLE-QUALIFIED HARDWARE.

TDRS REQUIREMENTS SUMMARY - POWER

The dedicated power kit satisfies all the power requirements for the TDRS mission. Power will be provided a maximum of ten minutes before TOS/AMS TDRS deployment from the orbiter through TDRS separation from the AMS. Make-before-break switching is used to assure no power interruption occurs. Isolation diodes is provided for reverse protection. Also, during a potential STS abort, the STS/TOS/AMS system will provide and distribute power to the TDRS (within the limits of the system).

TDRS REQUIREMENTS SUMMARY - POWER

<u>REQUIREMENTS</u>	<u>COMPLIANCE</u> BASIC DESIGN KIT	<u>REMARKS</u>
PROVIDE POWER FROM A MAXIMUM 10 MINUTES BEFORE TOS/AMS/TDRS DEPLOYMENT THROUGH AMS/TDRS SEPARATION.	X	POWER KIT.
BEFORE LAUNCH THE INPUT POWER SHALL BE TRANSFERRED FROM STS GROUND POWER (T-O) TO THE ONBOARD ORBITER POWER SOURCE, FROM WHICH TDRS SHALL CONTINUE TO RECEIVE REGULATED ELECTRICAL POWER DISTRIBUTED BY THE TOS/AMS DURING ASCENT & ON-ORBIT PHASES.	X	POWER KIT.
AMS POWER KIT SHALL PROVIDE MAKE-BEFORE-BREAK SWITCHING TO ASSURE NO POWER INTERRUPTION	X	POWER KIT.
ISOLATION DIODES SHALL BE PROVIDED FOR REVERSE CURRENT PROTECTION.	X	POWER KIT.
TOS/AMS SHALL PROVIDE DEDICATED BATTERIES TO SUPPLY THE TDRS AVERAGE POWER DEMAND AT A MINIMUM OF 24 VDC AT THE AMS/TDRS ADAPTER INTERFACE.	X	POWER KIT.
DURING AN STS ABORT THE STS/TOS/AMS SYSTEM SHALL PROVIDE & DISTRIBUTE ELECTRICAL POWER TO THE AMS/TDRS INTERFACE WITHIN THE ENERGY LIMITS OF THE SYSTEM.	X	POWER KIT.

TDRS REQUIREMENTS SUMMARY - POWER

The TOS/AMS power requirements for TDRS are presented as a function of time. A peak of 1065w is required over a period of 7 hours and 3 minutes. An average of 580w is necessary for a maximum of 6 hours and 3 minutes. An additional average of 605w is needed for a maximum of 32 minutes. The TDRS initiates power at a maximum of 15 minutes before the AMS and TDRS separation.

TDRS REQUIREMENTS SUMMARY - POWER

Osc

MARTIN MARIETTA

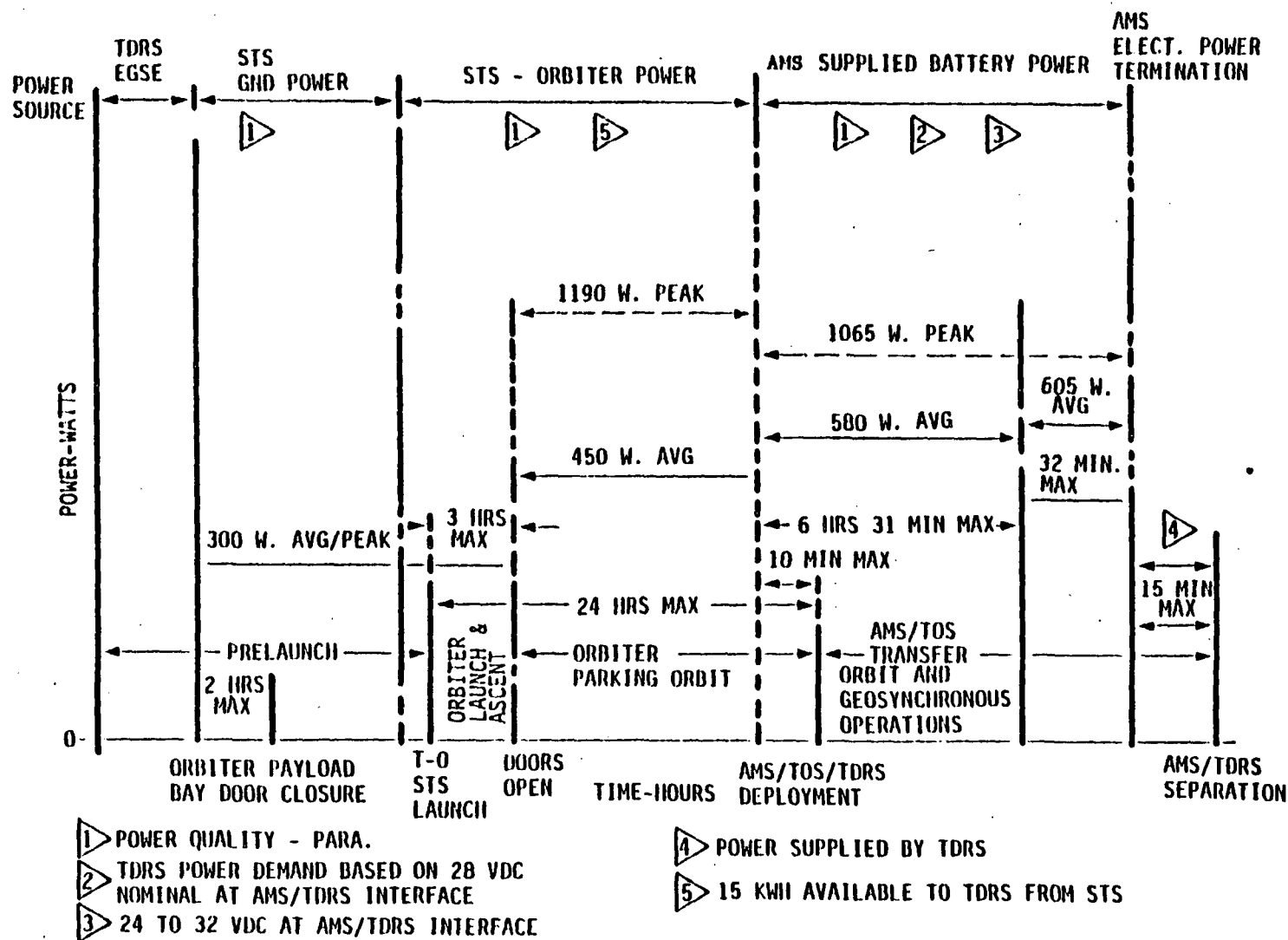

TDRS REQUIREMENTS SUMMARY - ORDNANCE FIRING

The basic TOS/AMS redundant sequencer and the telemetry and command kit satisfy the TDRS ordnance firing requirements. There are two groups of two TDRS ordnance initiators. The TOS/AMS provides one firing command to fire each group of the two initiators. The firing pulse duration is for a minimum of 40 ms. There are two TDRS provided breakwires which are monitored by the AMS Telemetry function.

Osc

MARTIN MARIETTA

TDRS REQUIREMENTS SUMMARY - ORDNANCE FIRING

<u>REQUIREMENTS</u>	<u>COMPLIANCE</u> BASIC DESIGN KIT	<u>REMARKS</u>
TOS/AMS SYSTEM SHALL PROVIDE & DISTRIBUTE ORDNANCE FIRING POWER TO THE AMS/TDRS INTERFACE FOR TWO GROUPS OF TWO TDRS ORDNANCE INITIATORS.	X	SEQUENCING.
TOS/AMS SYSTEM ORDNANCE FIRING CURRENT SUPPLIED TO THE AMS/TDRS INTERFACE FOR EACH TDRS INITIATOR SHALL BE 5 A DC MINIMUM & THE SHORT CIRCUIT CURRENT SHALL BE 11 A MAXIMUM. THE FIRING PULSE DURATION SHALL BE 40 MS MINIMUM.	X	SEQUENCING
TOS/AMS SHALL PROVIDE THE PRIMARY ORDNANCE PULSE & THE BACKUP ORDNANCE PULSE WITH ± 5 MS OF EACH OTHER. THE TOS/AMS SHALL PROVIDE ONE FIRING COMMAND TO FIRE EACH GROUP OF TWO INITIATORS.	X	SEQUENCING.
AMS SYSTEM SHALL MONITOR TWO (2) TDRS PROVIDED BREAKWIRES. EACH CIRCUIT SHALL BE MONITORED BY THE AMS TELEMETRY SYSTEM TO INDICATE AN OPENING OF THE BREAKWIRES.	X	TELEMETRY & COMMAND KIT.

TDRS REQUIREMENTS SUMMARY - TELEMETRY

The telemetry and command kit, electrical/interface to the orbiter and the basic TOS/AMS redundant sequencer satisfy the TDRS telemetry requirements. The AMS has the capability of accepting unencrypted telemetry and transmitting it to the ground. A TDRS telemetry throughput capability to the orbiter is provided, as well as a prelaunch direct TDRS/Electrical Ground Support Equipment command transmission capability. The AMS sequencer provides the capability for eight primary and eight backup discrete commands.

TDRS REQUIREMENTS SUMMARY - TELEMETRY



MARTIN MARIETTA

<u>REQUIREMENTS</u>	<u>COMPLIANCE</u>	<u>REMARKS</u>
	BASIC DESIGN KIT	
AMS SHALL PROVIDE THE CAPABILITY OF ACCEPTING UNENCRYPTED TDRS TELEMETRY & TRANSMITTING TO GROUND.	X	TELEMETRY & COMMAND KIT.
AMS SHALL PROVIDE TDRS TELEMETRY THROUGH-PUT CAPABILITY TO THE ORBITER PDI.	X	ELECTRICAL INTERFACE TO ORBITER.
STS/AMS SHALL PROVIDE THE CAPABILITY TO THROUGHPUT TDRS TELEMETRY DATA UNENCRYPTED TO THE ORBITER T-O UMBILICAL.	X	ELECTRICAL INTERFACE TO ORBITER.
AMS SHALL INTERNALLY DERIVE TDRS EIGHT PRIMARY & EIGHT BACKUP DISCRETE COMMANDS.	X	AMS SEQUENCING.
TDRS SHALL BE PROVIDED WITH A PRELAUNCH DIRECT TDRS/EGSE COMMAND TRANSMISSION CAPABILITY.	X	ELECTRICAL INTERFACE TO ORBITER.

0325L/PPP/10

TDRS REQUIREMENTS SUMMARY - COMMUNICATIONS

The telemetry and command kit satisfies the TDRS communication requirements. This involves on-orbit RF checkout while attached to the orbiter, which encompasses two-minutes of real-time telemetry. Also, the TOS/AMS received and transmits to STDN an indication when the required TDRS appendage deployment orientation has been obtained. The AMS attitude is transmitted to the ground approximately two seconds before the AMS separates from the TDRS and verification is transmitted to the ground no later than 5 minutes after the TDRS is separated from the AMS.

Osc

MARTIN MARIETTA

TDRS REQUIREMENTS SUMMARY - COMMUNICATIONS

<u>REQUIREMENTS</u>	<u>COMPLIANCE</u> BASIC DESIGN KIT	<u>REMARKS</u>
TWO MINUTES OF REAL-TIME TELEMETRY COVERAGE FOLLOWING LOCKUP, FOR ON-ORBIT RF CHECKOUT WHILE ATTACHED TO THE ORBITER.	X	TELEMETRY & COMMAND KIT.
MAXIMUM OF FIVE AMS DIPOUT MANEUVERS SHALL BE PROVIDED. THE AMS SHALL ORIENT THE +Z AXIS WITHIN 20 DEG OF A GROUND STATION.	X	MANEUVERS FOR TDRS.
AMS SHALL RECEIVE & TRANSMIT TO STDN AN INDICATION WHEN THE REQUIRED APPENDAGE DEPLOYMENT ORIENTATION HAS BEEN ACHIEVED.	X	TELEMETRY & COMMAND KIT.
AMS SHALL TRANSMIT THE AMS ATTITUDE TO GROUND APPROXIMATELY 2 S BEFORE THE AMS/TDRS SEPARATION.	X	TELEMETRY & COMMAND KIT.
AMS SHALL TRANSMIT TO GROUND VERIFICATION OF AMS/TDRS SEPARATION NO LATER THAN 5 MINUTES FOLLOWING SEPARATION.	X	TELEMETRY & COMMAND KIT.

0325L/PPP/11

TDRS REQUIREMENTS SUMMARY - FLIGHT OPERATIONS

The TOS/AMS basic design using the inherent performance capabilities of the Ring Laser Gyro can satisfy the GSO injection accuracy requirements. The accuracy requirement was a key design driver and is discussed in more detail in the accuracy assessment section of this report. All of the TOS/AMS subsystems are designed to satisfy the TDRS 24.5 hrs deployment requirement.

TDRS REQUIREMENTS SUMMARY - FLIGHT OPERATIONS



REQUIREMENTS

COMPLIANCE

REMARKS

BASIC
DESIGN KIT

AMS SHALL PLACE TDRS INTO GSO WITH THE FOLLOWING ACCURACY* (3 SIGMA).

X

BASIC INHERENT RING LASER GYRO PERFORMANCE.

- SEMI-MAJOR AXIS ± 640 NMI
- INCLINATION ± 0.42⁰
- ECCENTRICITY ± .015

NOTE: *IUS WITH NO STELLAR UPDATED (PROPOSED)

TOS/AMS TDRS MISSION SHALL CONSIDER THAT TDRS MUST BE DEPLOYED IN 24.5 HRS.

X

USED FOR DESIGN OF ALL SUBSYSTEMS.

TOS/AMS SYSTEM DESIGN AND INTEGRATION

Optimum flight vehicle design is the result of not only vehicle subsystem development (such as propulsion, structures, avionics, etc) but of a thorough systems analysis. The evolving complexities of requirements, tradeoffs, and the premium placed on optimization and design excellence from a total system standpoint has further accented the role of systems engineering and integration in the design process. The TOS/AMS vehicle design is the result of a total systems analysis. The impact of the systems engineering and integration effort on the design included: (1) subsystems trade studies and major analyses; (2) system integration (Spacecraft and STS); (3) systems engineering specialities analyses (mass properties, reliability, environments, electromagnetic interference/compatibility (EMI/EMC), human factors and maintainability environmental impacts, logistics, and system safety); and (4) risk assessment analyses.

TOS/AMS SYSTEM DESIGN AND INTEGRATION

OSC

MARTIN MARIETTA

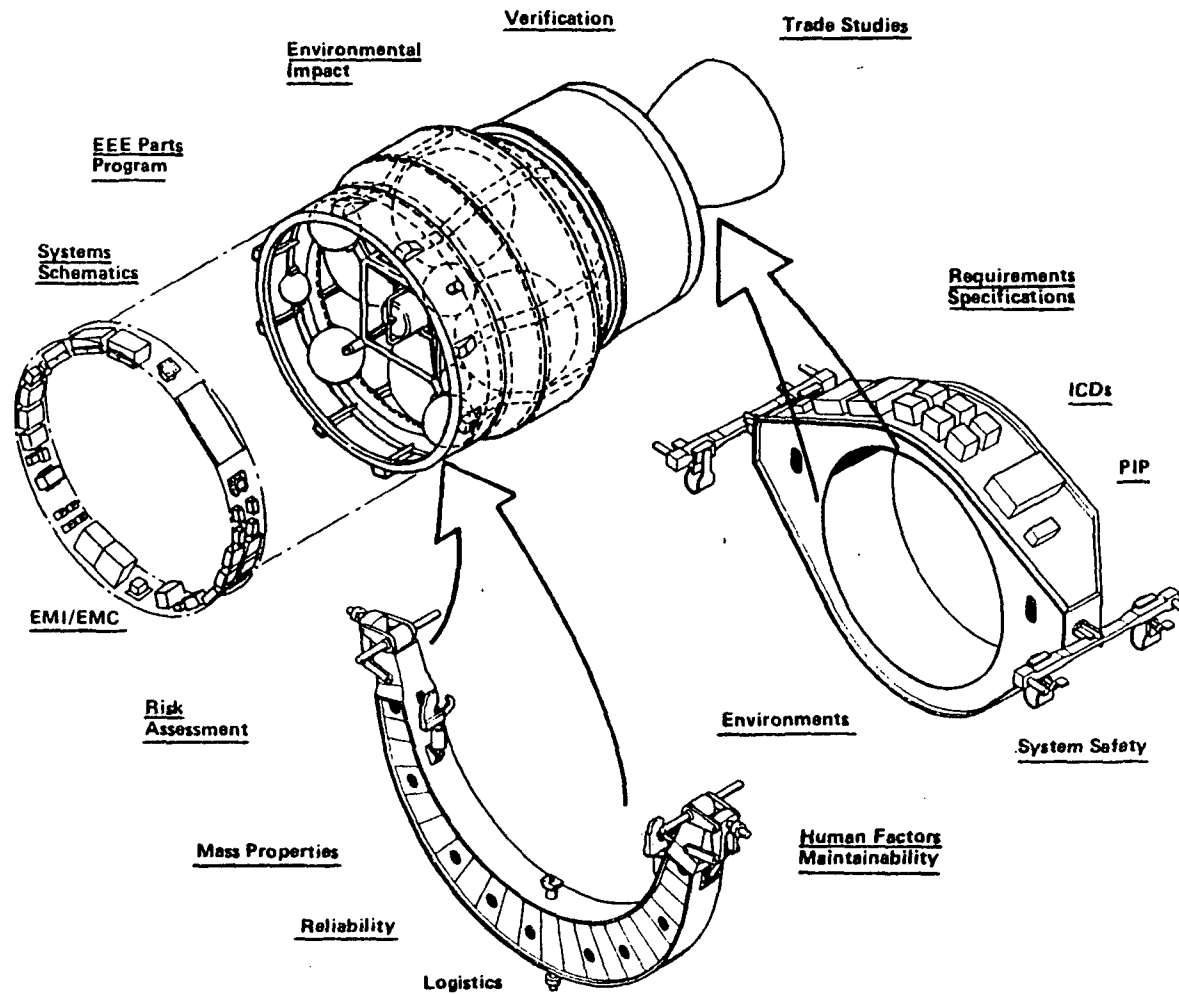

0325L/PPP/13

KEY DESIGN DRIVERS FOR TOS/AMS TDRS

Injection accuracy was the key design driver. The highly accurate RLG system provides the most cost-effective solution to TDRS insertion accuracy requirements, as discussed in the accuracy assessment section of this report. The guidance system is a simplified scheme requiring preprogrammed inertial burn attitudes, maneuvers, and times. This simplified guidance concept is possible owing to: (1) the extreme accuracy of the orbiter deployment state and handoff, and (2) the low scale factor and fixed-drift rate errors of the RLGs' instrument itself. The system includes a dual-redundant set of RLG, 3-DOF accelerometers, and computers in a prime/backup configuration to provide appropriate redundancy. The system is initialized in the orbiter and use a velocity shutdown for AMS main engine burns for precise insertion accuracy.

To satisfy the reliability design driver, the TOS/AMS system, consisting of the flight vehicle and airborne support equipment (ASE), is designed to provide a minimum mission success probability of 0.96 for the flight phase. The design approach makes maximum use of space-qualified hardware developed on other successful programs. The piece-part levels for this program were likewise established to provide cost-effective, yet reliable, space-proven components. The system environments and operating requirements are thoroughly analyzed and are integrated into the reliability analysis.

The use of the IUS ASE impacted the length and external shape of the AMS structure.

KEY DESIGN DRIVERS FOR TOS/AMS/TDRS



MARTIN MARIETTA

0 INJECTION ACCURACY

0 RELIABILITY (0.96)

- SPACE-QUALIFIED HARDWARE
- SELECTED REDUNDANCY
- MINIMAL SINGLE POINT FAILURES

TOS/AMS PREDICTED RELIABILITY EXCEEDS ALLOCATION

	ASE	TOS	AMS
STRUCTURES & MECH	0.9985	0.9999	0.9990
PROPULSION	-	0.9884	0.9942
AVIONICS	0.9975	-	0.9878
THERMAL CONTROL	0.9999	0.9999	0.9998
ORDNANCE	0.9999	0.9999	0.9999
<u>TOTAL</u>	<u>0.9958</u>	<u>0.9881</u>	<u>0.9808</u>

0 USE OF IUS ASE

0 COST

0 WEIGHT

COMBINED TOS/AMS SYSTEM RELIABILITY = 0.965
ALLOCATION = 0.960

0 SAFETY

CRITICAL SUBSYSTEM RELIABILITY PREDICTIONS EXCEED ALLOCATIONS

The reliability predictions for the critical avionics and propulsion subsystems were defined and compare quite favorably with their allocations. The dual redundant RLG helps increase the avionics reliability prediction. The selected redundancy as presented in the appropriate subsystem discussions was implemented to meet reliability requirements as well as safety requirements. A minimal number of single-failure points remain in the design and these items were given special attention.

CRITICAL SUBSYSTEM RELIABILITY PREDICTIONS EXCEED ALLOCATIONS

OSC

MARTIN MARIETTA

SUBSYSTEM	COMPONENT	RELIABILITY
AVIONICS	RLG	.996400
	TVC ELECTRONICS	.997445
	SEQUENCER	.999986
	ELECTRICAL POWER	.999482
	AVIONICS TOTAL	.993325
	ALLOCATION	.9878
PROPULSION	TANKS	.999406
	ISOLATION VALVES	.999626
	REGULATOR	.999827
	RELIEF VALVE	.999917
	CHECK VALVES	.999870
	FILTERS	.999924
	THRUSTER & TVA	.999140
	RCS THRUSTERS	.999770
	LINES AND FITTINGS	.999840
	PROPULSION TOTAL	.997323
		ALLOCATION

TRADE STUDIES ESTABLISHED CRITICAL TOS/AMS SUBSYSTEMS

The TOS/AMS flight vehicle design analysis effort was organized into two areas: trade studies and major analyses. Trade studies were conducted to select the best option from a candidate list of options, whereas analyses consisted primarily of calculations and design development. Because the TOS/AMS system maximizes use of off-the-shelf hardware, numerous trade studies were accomplished and are briefly described below.

Major subsystem trade studies were primarily accomplished for the propulsion and avionics subsystems. Four significant propulsion trade studies were accomplished in the following areas: (1) main engine (2) Reaction Control System (RCS) (3) main propellant tanks and (4) pressurization system tanks. These studies addressed over two dozen potential options that resulted in the selection of the 2650-lb-thrust Rocketdyne main engine, the simplified L-SAT main propellant tank, the TOS (Hamilton Standard) 30-lb thrust monopropellant rocket engine modules (REM) for the RCS, and the ARDE 22-in. tanks for the pressurization system.

The primary avionics trade study addressed four guidance and control system approaches. The dual-string RLG system was selected as discussed previously.

TRADE STUDIES ESTABLISHED CRITICAL TOS/AMS SUBSYSTEMS

OSC

MARTIN MARIETTA

MAIN PROPULSION TRADE STUDY

- O SELECTED 2650 LB ROCKETDYNE ENGINE
 - DECREASED COST
 - INCREASED RELIABILITY
 - INCREASED THRUST/PERFORMANCE

REACTION CONTROL SYSTEM TRADE STUDY

- O SELECTED 30 LB TOS/HAMILTON STD REMS
 - DECREASED COST
 - SAME AS USED ON TOS
 - INCREASED ASSURANCE OF ATTITUDE CONTROL

MAIN PROPELLANT TANK STUDY

- O SELECTED L-SAT TANK WITH SIMPLIFIED PMD
 - DECREASED COST
 - SIMPLER
 - LIGHTER

PRESSURIZATION SYSTEM TANKS

- O SELECTED 22 IN. ARDE PRESSURIZATION TANKS
 - OPTIMIZED PERFORMANCE

AVIONICS

- O SELECTED THE RING LASER GYRO

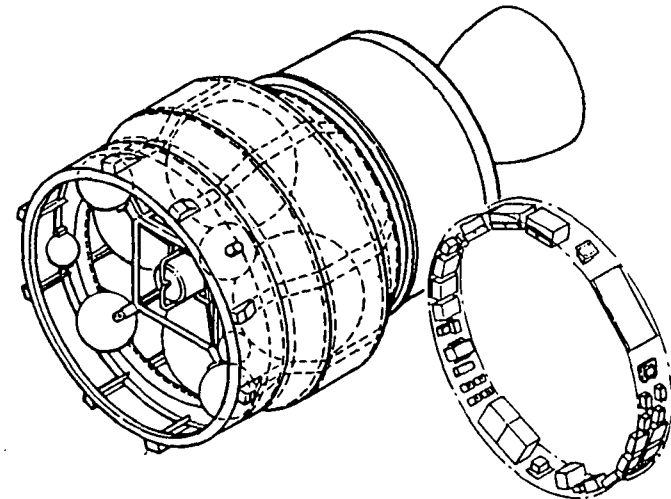

TOS/AMS WEIGHT SUMMARY

Appropriate contingency factors were used to develop realistic TOS/AMS system weights for the TDRS mission, 20% contingency was used on new and modified items and 5% contingency was used on existing items. The first stage is the solid rocket motor propelled TOS and the second stage is the restartable liquid bipropellant AMS. The four most significant elements that comprise the TOS/AMS system for TDRS are the TOS solid rocket motor (SRM-1), the AMS liquid bipropellant propulsion system, the reaction control system and the avionics. All of these elements are based on proven hardware.

TOS/AMS WEIGHT SUMMARY

QSC

MARTIN MARIETTA

<u>ITEM</u>	<u>AMS</u>	<u>WT. (LBS)</u>	<u>ITEM</u>	<u>WT. (LBS)</u>
STRUCTURE/ENVIROM CONTROL		573.2	STRUCTURE/ENVIROM PROTECT.	417.1
PROPULSION/RCS		614.6	PROPULSION	1506.4
AVIONICS/POWER		643.5	TVC/POWER DIST.	46.0
CONTINGENCY		<u>213.8</u>	CONTINGENCY	<u>167.9</u>
DRY WEIGHT		2045.1		2137.4

DETAIL AMS WEIGHTS FOR TDRS MISSION

The structure weights are for items that use conventional aluminum alloy skin/stringer construction and has been used in previous spacecraft and/or Titan vehicles.

The environmental control weights are for a passive thermal approach. The thermal approach encompasses available insulation, paint, and tank and line heaters.

DETAIL AMS WEIGHTS FOR TDRS MISSION

QSC

MARTIN MARIETTA

<u>STRUCTURE</u>	<u>DRY WT</u> (533.2)	<u>CONT</u> (106.6)	<u>TOTAL</u> (639.8)
SPACECRAFT I/F SUPPORT RING	20.0		
S/C I/F BOLT RING BRACKETS	19.2		
FWD RING AT ATTACH POINT (W/PINS)	160.0		
INTERMEDIATE RING FRAME - FWD	30.0		
INTERMEDIATE RING FRAME - AFT	20.0		
SEPARATION RING FRAME	15.0		
SEPARATION STRUCTURE (BOLT HALVES) (8)	12.0		
FWD CYLINDRICAL SKIN	35.4		
CONICAL SECTION SKIN	28.0		
AFT CYLINDRICAL SKIN	24.1		
STRINGER (24)	30.2		
LONGERONS (8)	37.2		
TANK SUPPORT BEAMS (BOX STRUCTURE)	47.4		
TANK SUPPORT RINGS	51.7		
ENGINE MOUNTING STRUCTURE	3.0		
<u>ENVIRONMENTAL CONTROL</u>	<u>(40.0)</u>	<u>(8.0)</u>	<u>(48.0)</u>
THERMAL BLANKET - FWD I/F	9.4		
MLI, FOLD INSUL, PAINT, MISC	28.1		
TANK & LINE HEATERS	2.5		

0325L/PPP/17

DETAIL AMS WEIGHTS FOR TDRS MISSION (CONT)

The propulsion/RCS system weights represent existing hardware. The liquid bipropellant main propulsion system engine is the Rocketdyne RS-49, which is based on the Peacekeeper Stage IV engine that has performed successfully on four flights. The reaction control system is based on the Hamilton Standard Rocket Engine Module (REM), which has flown on the IUS.

DETAIL AMS WEIGHTS FOR TDRS MISSION (CONT)

OSC

MARTIN MARIETTA

<u>PROPULSION/RCS SYSTEM</u>	<u>DRY WT</u> (614.6)	<u>CONT</u> (44.0)	<u>TOTAL</u> (658.6)
MAIN THRUSTER ENGINE (1)	103.0		
RCS THRUSTER ENGINES (12)	36.0		
PROPELLANT TANKS (45 IN) (4)	180.0		
PRESSURE TANKS (22.5 IN) (4)	164.0		
RCS PROPELLANT TANKS (16.5 IN) (2)	24.8		
VALVES-FILL/DRAIN (12)	2.4		
NC PYRO VALVE-HELIUM (3)	1.5		
NC PYRO VALVE-HYDRAZINE (1)	0.5		
NC PYRO VALVE-MMH/NTO (2)	2.2		
PRESSURE RELIEF VALVE (1)	1.2		
CHECK VALVE (2)	4.0		
FILTER PROPELLANT (3)	9.0		
PRESSURE TRANSDUCER (4)	2.0		
REGULATOR (1)	3.0		
FUEL LINES & ATTACH H/W	45.0		
RCS LINES & ATTACH H/W	11.6		
HELIUM LINES & ATTACH H/W	13.2		
TVC ACTUATORS (2)	11.2		

0325L/PPP/18

DETAIL AMS WEIGHTS FOR TDRS MISSION (CONT)

The Avionics/power weights are for state-of-the-art elements. The high-performance RLGs have flown on and met the demanding requirements of aircraft and high-speed, low level, terrain-following tactical missiles. The 175 AH batteries have been used on the Titan III Transtage. All of the Avionics components will be used first for the TOS which is presently under development.

DETAIL AMS WEIGHTS FOR TDRS MISSION (CONT)

QSC

MARTIN MARIETTA

<u>AVIONICS/POWER</u>	<u>DRY WT</u> (643.5)	<u>CONT</u> (55.2)	<u>TOTAL</u> (698.7)
RING LASER GYRO SYSTEM (2)	85.0		
INPUT/OUTPUT UNIT (1)	15.0		
REDUNDANT SEQUENCER (1)	17.0		
PYRO INITIATION CONTROLLERS (6)	42.0		
RELAY ASSEMBLY (1)	9.5		
SWITCH MOTOR DRIVEN (2)	7.8		
DIODE ASSEMBLY (2)	1.8		
BATTERIES - 175 AH (2)	162.0		
ELECTRICAL CABLING	40.0		
ATTACH H/W & MISC	57.0		

DETAIL AMS WEIGHTS FOR TDRS MISSION (CONT)

The Telemetry/Command Kit and Power Kit weights are for existing hardware. The same 175 AH battery, used on Titan III Transtage, is used for dedicated operation by TDRS.

In summary, proven hardware is used with appropriate contingency factors to develop realistic AMS system weights.

DETAIL AMS WEIGHTS FOR TDRS MISSION (CONT)

Osc

MARTIN MARIETTA

<u>TDRS TLM/COMMAND/TELEMETRY KIT</u>	<u>DRY WT</u>	<u>CONT</u>	<u>TOTAL</u>
- SIGNAL CONDITIONERS/TRANDUCERS	10.0		
- PCM ENCODER	7.0		
- S-BAND TRANSPONDER	15.0		
- POWER AMPLIFIER	10.0		
- RF SWITCH	2.0		
- ANTENNAS (2)	3.0		
- 10-VOLT POWER SUPPLY	9.0		
- DIPLEXER (1)	2.0		
- SWITCH-MOTOR DRIVEN	3.9		
- ELECTRICAL CABLING/CONNECTORS	15.0		
- ATTACH H/W & MISC	11.5		
<u>TDRS POWER KIT</u>			
- BATTERY - 175 AH	81.0		
- SWITCH - MOTOR DRIVEN	3.0		
- CONNECTOR (TOS/AMS)	2.0		
- CONNECTOR (AMS/TDRS)	2.0		
- WIRING	15.0		
- ATTACH H/W & MISC	15.0		
TOTAL AMS DRY WEIGHT	(1831.3)	(213.8)	2045.1)

20 PERCENT CONTINGENCY ON NEW AND MODIFIED ITEMS, 5 PERCENT CONTINGENCY ON EXISTING ITEMS.

DETAIL TOS WEIGHTS FOR TDRS MISSION

The TOS weights result from the existing TOS program which is presently under development. The solid rocket motor (from United Technology) has performed flawlessly on 12 consecutive ground tests, and two space missions. The TOS structural uses conventional aluminum alloy skin/stringer construction.

DETAIL TOS WEIGHTS FOR TDRS MISSION

QSC

MARTIN MARIETTA

<u>STRUCTURE</u>	<u>DRY WT</u> (417.1)	<u>CONT</u> (83.4)	<u>TOTAL</u> (500.5)
FORWARD RING FRAME	43.5		52.2
INTERMEDIATE RING FRAME	30.4		36.5
AFT RING FRAME	33.9		40.7
SKIN-CONICAL	83.0		99.6
SKIN-CYLINDRICAL	13.7		16.4
LONGERONS	56.0		67.2
STRINGERS	26.5		31.8
SEPARATION STRUCTURE	12.0		14.4
ATTACH H/W & MISC	29.9		35.9
MOTOR I/F TO S/Z SEPARATION	48.2		57.8
ENVIRONMENTAL PROTECT (MLI, PAINT, ETC.)	40.0		48.0
<u>PROPULSION</u>	(1506.4)	(75.3)	(1581.7)
SRM MOTOR DRY	1506.4	75.3	1581.7
<u>AVIONICS/POWER GEN & DISTR</u>	(46.0)	(9.2)	(55.2)
THRUST VECTOR CONTROLLERS (2)	26.0		31.2
ELECT CABLING	16.0		19.2
ATTACH H/W & MISC	4.0		4.8
	(1969.5)	(167.9)	(2137.4)

20 PERCENT CONTINGENCY ON NEW AND MODIFIED ITEMS; 5% CONTINGENCY ON EXISTING ITEMS.

ENVIRONMENTAL IMPACT ASSESSMENT (TASK 3.1.12)

A preliminary environmental impact assessment for using the TOS/AMS TDRS was conducted to identify any areas of concern/impact including utilization of the Space Transportation System (STS). This involved such items as the evaluation of the propulsion system propellant effects on the loss rate of ions and electrons in the ionosphere, space debris effects, and effects on air quality, water quality, and solid/toxic waste when the TOS/AMS is developed, tested, and manufactured.

The conclusion of the evaluation was that there was no impact. The effect of the TOS/AMS combustion products on the ionosphere is insignificant in terms of amount when compared to the STS. Also, insignificant impact is generated by the TOS/AMS development effort since existing facilities are used.

ENVIRONMENTAL IMPACT ASSESSMENT

O5C

MARTIN MARIETTA

TASK (3.1.12)

"PERFORM AN ANALYSIS OF POTENTIAL IMPACTS TO THE ENVIRONMENT WHICH TOS/AMS MAY CREATE"

CONCLUSIONS (NO IMPACT)

- 0 THE ADDITIVE EFFECT OF TOS/AMS COMBUSTION PRODUCTS ON THE IONOSPHERE IS INSIGNIFICANT IN TERMS OF AMOUNT COMPARED TO STS.
- 0 INSIGNIFICANT IMPACT GENERATED BY TOS/AMS PROGRAM SINCE ONLY EXISTING SITES, BUILDINGS, LABOR, TEST FACILITIES ARE USED.

0325L/PPP/16

COMPARISON OF STS AND TOS COMBUSTION PRODUCTS

The TOS/AMS will not be deployed until the space shuttle is in the ionosphere at approximately 300 km. Combustion products from the TOS SRM propulsion system are shown. The chemical action of the SRM exhaust products on the electrons and ions in the F-region of the ionosphere results in the formation of ionospheric holes. However, when the TOS SRM combustion products are compared to the STS and Titan the ionospheric hole effects are insignificant.

COMPARISON OF STS AND TOS COMBUSTION PRODUCTS

QSC

MARTIN MARIETTA

SOLID ROCKET MOTORS

COMBUSTION PRODUCT	TWO SRMs SHUTTLE (LBS)	TOS WITH FULL FUEL LOAD (LBS)	TWO SRMs TITAN IIID (LBS)
HCL	474,700	4,515	178,784
H ₂ O	208,200	1,038	61,858
H ₂	46,300	584	21,228
CO	540,100	5,605	241,426
CO ₂	73,800	619	21,576
N ₂	194,700	1,761	71,948
AL ₂ O ₃	626,200	7,278	261,870
OTHER	7,000	-----	11,310
TOTAL	2,217,000	21,400	870,000

COMPARISON OF STS AND AMS COMBUSTION PRODUCTS

The AMS combustion products also, result in the formation of ionospheric holes. But they are insignificant when compared to the Shuttle OMS operation. None of these effects will persist for more than a day after the TOS/AMS burn. The "ionospheric hole" phenomenon occurs as all launch vehicles enter the ionosphere during burn.

COMPARISON OF STS AND AMS COMBUSTION PRODUCTS

QSC

MARTIN MARIETTA

MMH/NTO COMBUSTION PRODUCT	AMS WITH FULL FUEL LOAD (LBS)	SHUTTLE OMS OPERATIONS
WATER	1,935	6,264
N ₂	3,010	9,744
H ₂	108	336
CO ₂	2,365	7,656
TOTAL	7,400	24,000

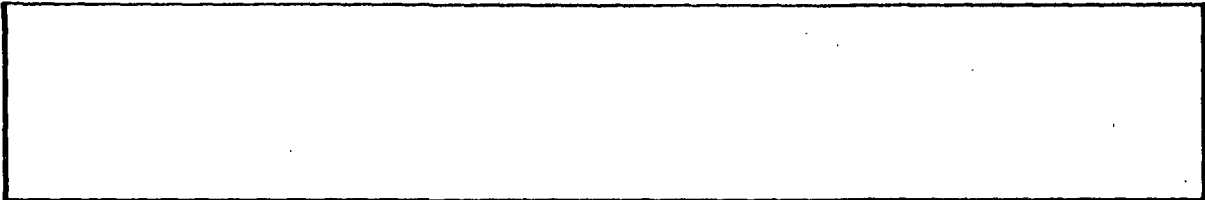

O5C

MARTIN MARIETTA

3.0 PERFORMANCE AND OPERATIONS

STS/TOS/AMS/TDRS MISSION PROFILE

The STS/TOS/AMS/TDRS mission profile is depicted beginning with the STS park orbit and ending with the TDRS final mission orbit.

The park orbit is the standard STS park orbit for a KSC launch: 160-nmi circular altitude inclined 28.5 deg.

A hohmann transfer is used between the park orbit and final orbit. The TOS burn and a short AMS first burn is used to inject from park orbit into a 160 nmi by 19323 nmi elliptical transfer orbit, while simultaneously reducing the inclination by 2.2 deg. Near apogee in the transfer orbit, the AMS second burn injects into the desired final geostationary orbit at 19323-nmi circular altitude inclined 0 deg.

The performance requirement for the TDRS mission is to place a 5,000-lb spacecraft in geostationary orbit.

STS/TOS/AMS/TDRS MISSION PROFILE
(TASK NO. 3.1.1)

QSC

MARTIN MARIETTA

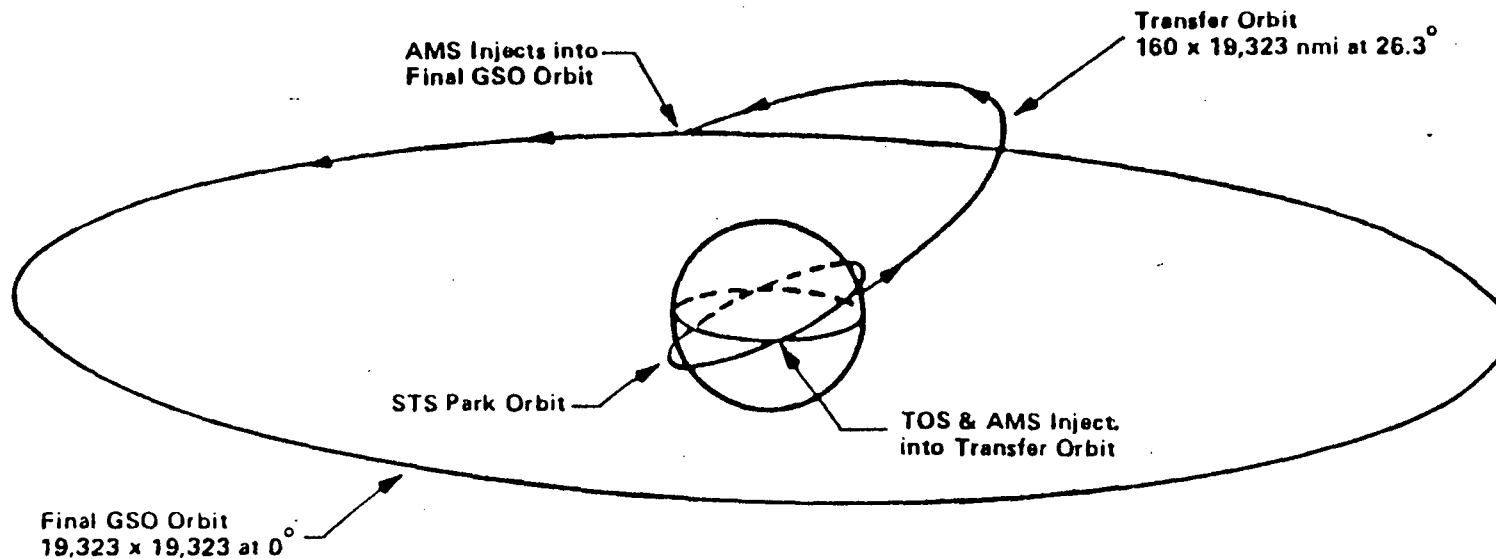

TDRS PERFORMANCE REQUIREMENT: 5,000 LBS IN GSO ORBIT

MISSION ASSESSMENT: 2-BURN VS 3-BURN

A coplanar mission overview is presented indicating differences in the mission profile for a two-burn versus three-burn scenario. The three-burn scenario was selected as our baseline operations sequence for the following reasons:

- 1) Improved maximum performance capability compared with a TOS-limited perigee inject;
- 2) Improved accuracy capability resulting from the engine-shutdown capability (on sensed velocity) of the liquid-fueled AMS;
- 3) Improved orbiter weight factors for spacecraft delivery missions allowing propellant offload, because the higher impulse propellant is retained in the AMS and the lower impulse propellant is off-loaded from the TOS.

There is a slight reduction in reliability associated with the 3-burn scenario compared to a 2-burn scenario. However, this reduction is insignificant compared against the total system reliability.

MISSION ASSESSMENT: 2-BURN VS. 3-BURN
 (TASK No. 3.1.13)

OSC

MARTIN MARIETTA

2-BURN

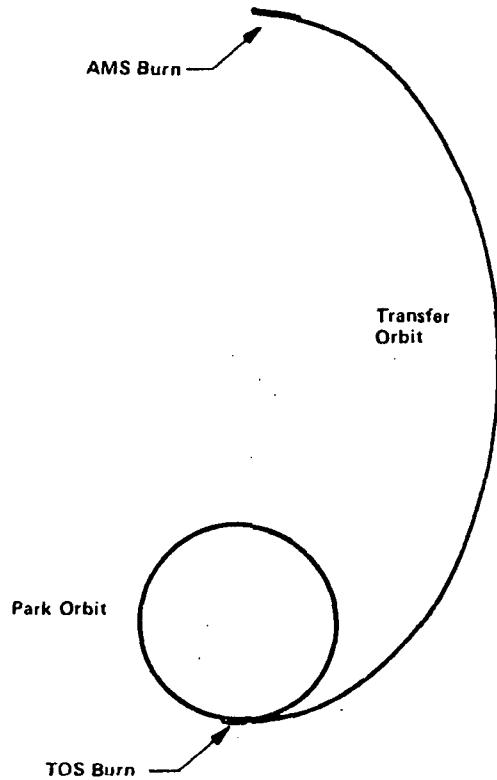

3-BURN

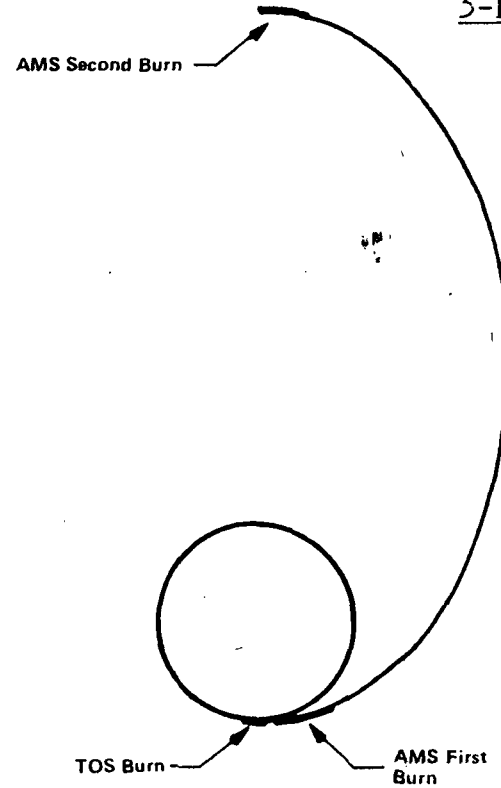

5393 LBS	MAXIMUM PERFORMANCE	5796 LBS
0.997480	PROPULSION SYSTEM RELIABILITY	0.997323
540/.04/.63	ACCURACY (SMA/E/1)	230/.01/.41

TOS/AMS WEIGHT SUMMARY FOR TDRS

The TOS/AMS vehicle weights are summarized for the TDRS mission application. Stage dry weights for the TOS and AMS include contingencies as discussed on page 37 A of this report.

AMS burnout weight includes trapped propellants, outage, pressurants, and flight performance reserves (FPR) for both the main and attitude control propulsion systems. These data are derived from the AMS propellant inventory (page 50), FPR calculation (page 51), and RCS propellant use schedule (page 52) for the TDRS application.

Stage loaded weights reflect a fully-loaded AMS and a slightly off-loaded (86.6% capacity) TOS motor. The TOS ablative material was scaled linearly to correspond to this propellant load.

QSC**MARTIN MARIETTA**

TOS/AMS WEIGHT SUMMARY FOR TDRS
(TASK NO. 3.1.1)

Dry Weight	2,137	2,045
Pressurant	-	32
Propellant Vapor	-	8
Trapped Propellant	-	50
Mean Outage	-	55
Main Propellant Reserve	-	150
RCS Propellant Reserve	-	24
Igniter	4	-
Ablatives Consumed	-78	-
Burnout Weight	2,055	2,364
Usable Main Propellant	18,542	7,135
Usable RCS Propellant	-	94
Igniter	4	-
Ablative Material	78	-
Gross Weight	20,679	9,593

Note:

- 1) All weights in lbs.
- 2) Burnout weights exclude RCS usage schedule.
- 3) TOS ablatives are scaled linearly to SRM % load.

AMS PROPELLANT INVENTORY

The AMS propellant inventory is shown for a fully loaded stage flown in a GSO mission application.

The helium gas (pressurant) weight of 32 lbs is carried directly in the stage burnout weight. Propellant vapor, trapped propellants, mean outage, and FPR are termed non-usable propellant and are subtracted from the propellant load to determine the nominal usable propellant. The non-usable propellant weight is carried in the stage burnout weight for performance determination.

AMS PROPELLANT INVENTORY
(TASK NO. 3.1.1)

QSC

MARTIN MARIETTA

	Fuel (lbm)	Oxidizer (lbm)	Total (lbm)
Helium Gas			32
Propellant Vapor Trapped	2	6	8
- Lines	9	7	16
- Tank	13	21	34
Mean Outage			55
Flight Performance Reserve	57	95	150
Unusable Propellant			263
Usable Propellant	2692	4443	7135

AMS FLIGHT PERFORMANCE RESERVES

Derivation of the FPR required for the TOS/AMS/TDRS mission is shown. Eight parameters directly affecting system performance were identified and their 3-sigma dispersions established. The effect of each dispersion on performance capability was determined, and an equivalent amount of AMS propellant margin (required to compensate for the dispersion) computed. The individual propellant margin requirements were then RSS'd to establish an effective 3-sigma margin required.

This FPR is totally available to offset low-performing TOS and/or AMS stages. Its availability guarantees, within a 3-sigma consideration, a velocity-shutdown of the AMS to achieve a nominal mission.

AMS FLIGHT PERFORMANCE RESERVES
(TASK NO. 3.1.1)



MARTIN MARIETTA

Performance Parameter	Nominal Value	3-Sigma Dispersion	AMS Prop. Margin Required
TOS ISP	292.66 s	± 1.47 s	31 lbs
TOS Propellant	18,624 lbs	± 20 lbs	4 lbs
TOS Dry Weight	2,137 lbs	± 10 lbs	2 lbs
AMS Outage	55 lbs	180 lbs	125 lbs
AMS ISP	315.00 s	± 4.5 s	74 lbs
AMS Propellant	7,135 lbs	± 20 lbs	6 lbs
AMS Dry Weight	2,045 lbs	± 10 lbs	7 lbs
AMS RCS Margin	24 lbs	± 24 lbs	17 lbs
3-Sigma (RSS) Margin Required = 150 lbs			

TOS/AMS RCS PROPELLANT USE SCHEDULE FOR TDRS

The RCS propellant use schedule is presented for the TOS/AMS/TDRS mission. Propellant usage is shown sequentially beginning at deployment. Total usage predicted is 94 lbs. A contingency reserve of 25% is carried in the AMS burnout weight, resulting in a total RCS propellant load of 118 lbs.

For performance determination purposes, the RCS use schedule is factored into the mission sequential weights presented on page 53 of this report.



MARTIN MARIETTA

TOS/AMS RCS PROPELLANT USE SCHEDULE FOR TDRS
(TASK NO. 3.1.7)

Mission Event	RCS Propellant Used (lbs)
Deployment	0.0
3-Axis Stabilization	5.7
S/C Thermal Conditioning	13.5
Orient for Perigee Burn	5.7
Roll Control - TOS Burn	0.5
AMS Propellant Settling	8.0
S/C Thermal Conditioning	4.7
S/C Telemetry Dipout No. 1	2.1
S/C Thermal Conditioning	4.7
S/C Telemetry Dipout No. 2	2.1
S/C Thermal Conditioning	5.7
S/C Telemetry Dipout No. 3	2.1
S/C Thermal Conditioning	4.8
S/C Telemetry Dipout No. 4	2.0
S/C Thermal Conditioning	4.7
S/C Telemetry Dipout No. 5	1.9
S/C Thermal Conditioning	9.3
AMS Propellant Settling	5.0
Roll Control - AMS Burn	1.6
Orient for S/C APP Deployment	2.3
Orient for S/C Separation	1.1
Collision Avoidance - Maneuver	6.5
Contingency Reserve (25%)	24.0
Total RCS Load (lbs)	118.0

TOS/AMS/TDRS PERFORMANCE SUMMARY

The GSO performance capability is summarized for the TOS/AMS as modified for the TDRS mission application. The maximum GSO capability of the basic TOS/AMS is 6032 lb using present predicted performance for the TOS. For the specific TDRS application, a kit is added to the AMS to provide power to the TDRS spacecraft, the AMS structure is modified to accommodate the IUS cradle, and a command capability is added to the basic telemetry system. The resulting maximum GSO capability for the TDRS-modified TOS/AMS is 5796 lbs, yielding a performance margin of about 800 lbs compared to the 5000-lb on-orbit requirement.

In generating this performance, two performance-estimation techniques are used to establish capability of the TOS/AMS. The standard rocket equation is used in generating spacecraft weight versus delta-V curves and to determine performance sensitivities. Three degree-of-freedom trajectory simulations are used for generation of design reference missions and to evaluate performance losses due to gravity and thrust-vectoring effects. The specific impulse is downgraded to account for total mass flow of TOS solid propellant, AMS main propellant, and ablatives expended during TOS and AMS burns. For the TOS, the propellant specific impulse of 293.5 sec is downgraded to an effective value of 292.66 sec; total mass expended is 21493 lb (4 lb igniter, 21399 lb solid, 90 lb inerts) for a fully loaded motor. For the AMS, the effective specific impulse is 315 sec; total mass expended is 7135 lb.

TOS/AMS/TDRS PERFORMANCE SUMMARY
(TASK NO. 3.1.1)

QSC

MARTIN MARIETTA

	TDRS Wt	Maximum
(1) Wt Into Final Orbit	5,000	5,796
(2) AMS Burnout Weight	2,376	2,376
Wt - End Apogee Burn	7,376	8,172
AMS Propellant Burned at Apogee	5,764	6,386
WT - Start Apogee Burn	13,140	14,558
RCS Propellant Used in Transfer Orbit	49	49
Wt - End Perigee Burn	13,189	14,607
AMS Propellant Burned at Perigee	1,371	749
Wt - Start AMS 1st Burn	14,560	15,356
(2) TOS Burnout Weight	2,063	2,051
Wt - End TOS Burn	16,623	17,407
TOS Propellant Wt	18,624	21,493
Wt - Start TOS Burn	35,247	38,900
RCS Propellant Used in Park Orbit	25	25
STS Deployed Weight	35,272	38,925
ASE Weight	5,713	5,713
STS Chargeable Weight	40,985	44,638

- (1) Final orbit is 19,323 x 19,323 at $i = 0$ deg;
Park orbit is 160 x 160 at $i = 28.5$ deg.
- (2) TOS & AMS B/O wts reflect RCS usage schedule; TOS ablatives scaled linearly to SRM percent load.

TOS/AMS STS LOAD FACTORS FOR TDRS

The TOS/AMS STS load factors are shown for the TDRS mission application. The STS chargeable weight of 40985 lbs (from page 53 A) translates into a weight load factor of 63.1% assuming a 65000-lb orbiter capability. The STS chargeable length of 35.9 ft includes 20.0 ft of TDRS length and 15.9 ft of TOS/AMS length, and translates into a length load factor of 59.8%.

Since the weight load factor is greater than the length load factor, a length margin of approximately 2.0 ft exists for this TOS/AMS application.

TOS/AMS STS LOAD FACTORS FOR TDRS
(TASK NO. 3.1.1)

QSC

MARTIN MARIETTA

WEIGHT LOAD FACTOR = 0.631
(CHARGEABLE WEIGHT = 40,985 LBS)

LENGTH LOAD FACTOR = 0.598
(CHARGEABLE LENGTH = 35.9 FT.)

LENGTH MARGIN = 2.0 FEET

TOS/AMS GSO PAYLOAD WEIGHT SENSITIVITIES

Payload weight sensitivities are shown for the TOS/AMS/TDRS mission application evaluated at the maximum GSO capability of 5796 lbs. Sensitivities are shown for perturbations in specific impulse, propellant weight, and dry weight for both the TOS and AMS stages.

The payload sensitivity to AMS propellant weight (1.42 lbs/lb) is generated assuming that 1 lb of nonusable propellant carried in the burnout weight is transformed into 1 lb of usable propellant; hence the partial is greater than 1.0. The sensitivity for adding usable propellant by increasing tank capacity (without decreasing nonusable propellant) is 0.42 lbs/lb.

TOS/AMS GSO PAYLOAD WEIGHT SENSITIVITIES
(TASK 3.1.1)

Osc

MARTIN MARIETTA

STAGE IN WHICH PERTURBATION INTRODUCED	PERTURBATION		
	SPECIFIC IMPULSE	PROPELLANT WEIGHT	DRY WEIGHT
TOS	29.6 LBS/SEC	0.28 LBS/LB	-0.34 LBS/LB
AMS	23.0 LBS/SEC	1.42 LBS/LB	-1.00 LBS/LB

NOTES: 3-BURN MISSION SCENARIO
TOS/AMS MODIFIED FOR TDRS

TOS/AMS ACCURACY FOR TDRS

The injection accuracy capability of the TOS/AMS is summarized for the TDRS mission application in terms of 3-sigma dispersions in final orbit parameters (semimajor axis, inclination, and eccentricity). Included on this chart are injection accuracy requirements for the IUS with and without stellar updates (STS-100 and proposed, respectively), as well as TDRS propellant requirements to correct the final orbit to ground station look angles (see page 57 A) of 0.0 and 0.1 deg.

The TOS/AMS baseline guidance system meets the proposed TDRS requirements for correcting all final orbit dispersions. This is accomplished with typical nominal RLG error source values, requiring no special vendor-selection process. These performance estimates assume that an in-bay Orbiter/AMS transfer alignment is performed with an accuracy of 0.2 deg (3-sigma) per axis. As shown, the baseline RLG system results in an injection accuracy capability that requires only 75 lb of TDRS propellant for total correction. This can be further reduced by about 40% if tighter vendor selection is invoked.

TOS/AMS ACCURACY FOR TDRS
(TASK NO. 3.1.2)

QSC

MARTIN MARIETTA

	3 - SIGMA FINAL ORBIT DISPERSIONS			TDRS CORRECTION	
	SEMIMAJOR	INCLINATION	ECCENTRICITY	PROPELLANT REQD (LBS)	
	AXIS (NMI)	(DEG)	(ND)	$\delta = 0.0^0$	0.1^0
STS-100 EQUIVALENT	124	0.12	0.008	37 (1)	32
PROPOSED REQUIREMENT	640	0.42	0.015	123	117
TOS/AMS BASELINE CAPABILITY	230	0.41	0.010	71 (2)	61
TOS/AMS ENHANCED CAPABILITY	191	0.23	0.007	48 (2)	40

(1) COMPARES TO 62 LBS SHOWN IN BAC 2-3933-0031-262, DATED FEB 1, 1984.

(2) MMDA MONTE CARLO ANALYSIS RESULTS SHOW 71 LBS AND 46 LBS, RESPECTIVELY.

AZIMUTH/ELEVATION RELATIONSHIP TO ECCENTRICITY/INCLINATION

The relationship of ground station look angles to inclination and eccentricity errors in the final GSO orbit is shown. A latitude of 35°N was assumed for the ground station. At this latitude, an elevation look angle tolerance of ± 0.1 deg maps into an allowable inclination dispersion of .0855 deg. Similarly, an azimuth tolerance of ± 0.1 deg maps into an allowable .00087 eccentricity dispersion. These allowable inclination and eccentricity dispersions were used in determining the propellant requirements for correction to 0.1 deg look angle (page 56).

AZIMUTH/ELEVATION RELATIONSHIP TO ECCENTRICITY/INCLINATION
(TASK 3.1.2)

OSC

MARTIN MARIETTA

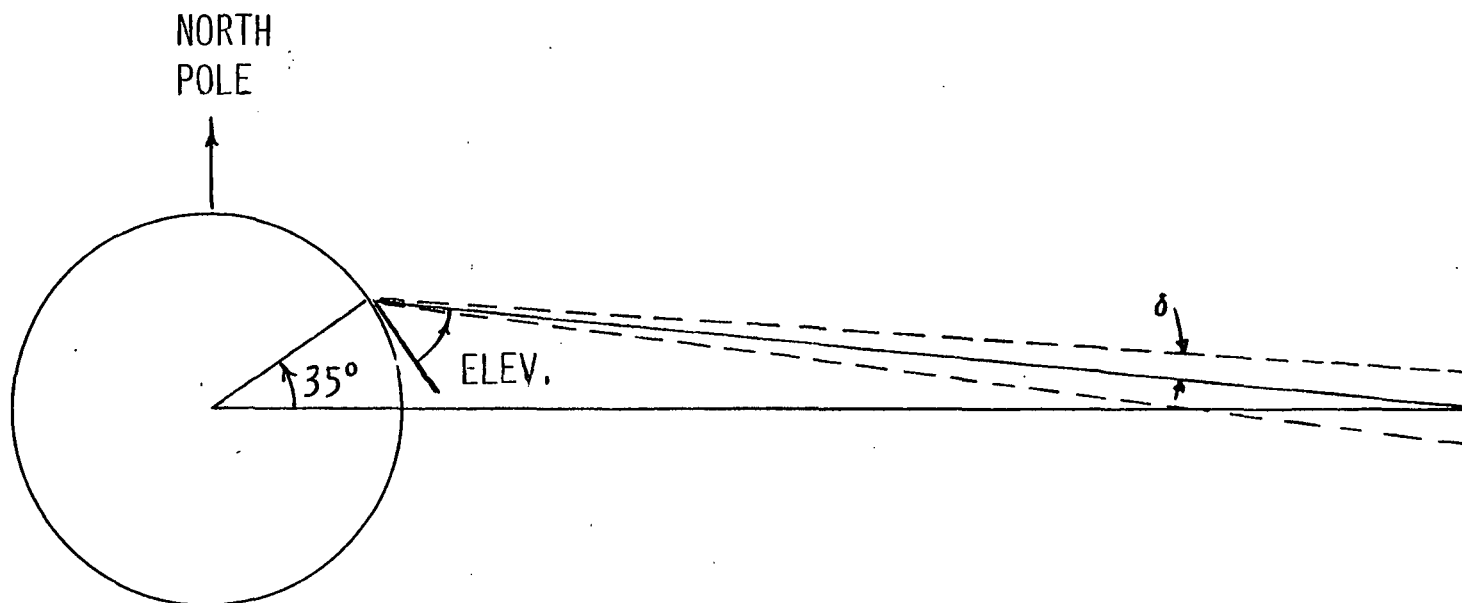

$\Delta \text{ELEVATION} = \pm 0.1 \text{ DEG} \rightarrow \Delta I = 0.0855 \text{ DEG} \rightarrow \pm 35 \text{ NMI OUT-OF-PLANE DRIFT}$
 $\Delta \text{AZIMUTH} = \pm 0.1 \text{ DEG} \rightarrow \Delta E = 0.00987 \rightarrow \pm 40 \text{ NMI IN-PLANE DRIFT}$

TOS/AMS GROUND OPERATIONS OVERVIEW FOR TDRS

An overview of the TOS/AMS/TDRS ground operations is shown. TOS/AMS activity at the launchsite in preparation for TDRS integration will be accomplished in an offline hazardous processing facility (HPF) such as SAEF-2 or the planned cargo hazardous servicing facility (CHSF). Following complete system verification testing, the TOS/AMS will be transferred to the vertical processing facility (VPF) for integration with the TDRS.

After arrival at VPF, the GSE transporter is cleaned and its cover removed. It is then moved into the high bay and configured for TOS/AMS removal and insertion in the vertical payload handling device (VPHD), and prepared for TDRS integration. TOS/AMS/TDRS integration and interface tests are then jointly accomplished. All hardwire connections from the aft flight deck (AFD) and T-0 umbilicals will be verified and an abbreviated mission simulation run. The entire cargo will then be transferred from the VPHD into the payload canister for transportation to the pad.

At the pad, the transporter will position the canister at ground level below the rotating service structure (RSS) crane. The canister will be hoisted to the PCR door level and locked into position. The cargo will be transferred out of the canister by the payload ground handling mechanism (PGHM) and into the payload changeout room (PCR). The PCR and canister doors will then be closed and the canister lowered and removed. TDRS will then perform systems checks such as telemetry, tracking, and command (TT&C); power-on tests; battery conditioning; and RCS fueling.

After the crawler transporter moves the Shuttle to the pad and the mobile launch platform is positioned, the RSS will be rotated for transfer of the cargo into the orbiter. The cargo will be installed in the orbiter cargo bay by the Shuttle processing contractor using the PGHM. During this period, 8 hours has been allocated for cargo-unique testing.

TOS/AMS GROUND OPERATIONS OVERVIEW FOR TDRS
(TASK 3.1.13)

TOS/AMS Transporter

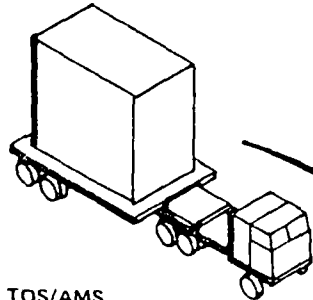

- TOS/AMS
- From Hazardous Processing Facility (SAEF-2 or CHSF)
 - Assembled & Checked Out
 - Vertical

Payload Processing Facility (PPF)
Building AO



TDRS Control Center

Vertical Processing Facility (VPF)

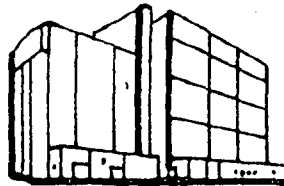

- TDRS Mate to TOS/AMS
- Mechanical & Electrical
- TDRS Functional Test
- TDRS Command & TM
- Compatibility Test
- TOS/AMS & TDRS I/F Verif
- Cargo Integration Testing
- Cargo Transfer from VPHD to Payload Canister

Launch Pad Rotating Service Structure (RSS) with Payload Changeout Room (PCR)

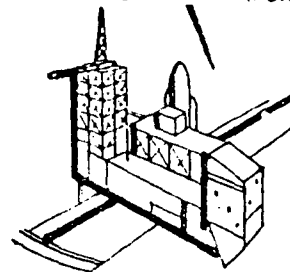

- Place Cargo in PGHM
- TDRS Propellant Servicing
- Systems Checks
- Cargo-to-Orbiter Mate
- Verification Tests & Closeout
- Payload Bay Door Closure, Approx T-29 Hrs
- Launch

TDRS Transportation Equipment

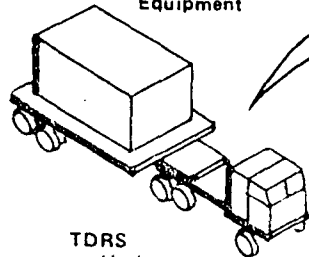

TDRS
- Horizontal

Air Carrier



TDRS Prime Mode to KSC

Payload Canister (Vertical) & Transporter

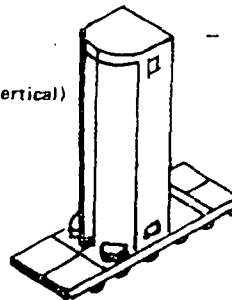

- Cargo Vertical

TOS/AMS/TDRS GROUND OPERATIONS TIMELINE

The ground operations timeline for TOS/AMS and TDRS is shown beginning with arrival at VPF and ending with launch. The timeline allows for approximately 8 weeks from VPF entry to launch. TOS/AMS and TDRS processing requirements in VPF would allow this timeline to be shortened significantly; however, other cargo element considerations led to baselining an 8-week timeline. A compressed timeline will be established after the STS flight manifest is defined.

Assembly and check-out of the TOS/AMS occurs in an offline hazardous processing facility prior to transport to VPF. The timeline presented on this chart from VPF arrival to launch supports the operations described on page 58 A of this report.

TOS/AMS/TDRS GROUND OPERATIONS TIMELINE
(TASK 3.1.13)



MARTIN MARIETTA

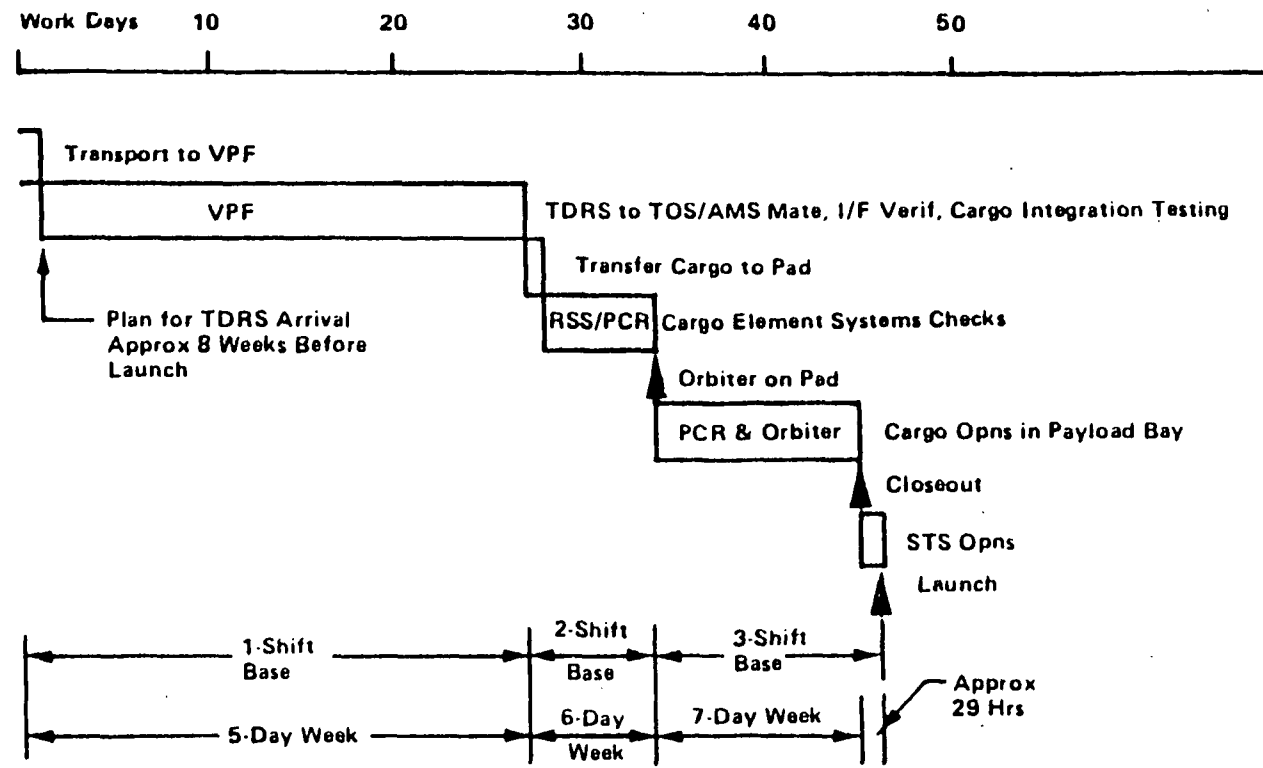

TOS/AMS FLIGHT OPERATIONS OVERVIEW FOR TDRS

An overview of the TOS/AMS/TDRS flight operations is shown. Launch will be from KSC leading to insertion of the orbiter into a nominal park orbit. TOS/AMS has provisions to route TDRS data for real-time downlink, or recording and subsequent near-real-time playback through the orbiter to the ground.

After orbiter payload-bay door opening, the TOS/AMS will be powered up and self-checks performed. TOS/AMS checkout activities are monitored from the multipurpose support room (MPSR) at NASA/JSC. TDRS checkout is conducted in coordination with the White Sands Ground Terminal (WSGT). Two and one-half hours are allocated for TDRS predeployment systems checks. TDRS telemetry may be routed through the AMS telemetry via hardline to the orbiter payload data interleaver (PDI) or via RF radiation to the orbiter payload interrogator (PI). TDRS RF link checkout to the ground is accommodated by a 2-minute telemetry transmission to the Goldstone tracking station (planned for transition to the deep-space network in 1985).

The next hour is used to perform final system checks, maneuver the orbiter to the deployment attitude, elevate the cradle to the deployment position, and achieve physical separation. Safe separation distance is achieved as a result of the separation velocity imparted by the cradle separation mechanism. The telemetry and reaction control systems are activated once safe separation is achieved. After control of the attitude is accomplished, the TOS/AMS maneuvers to the required TDRS thermal attitude and begins the 3-deg/s roll rate.

Telemetry coverage of the TOS SRM and AMS perigee burns will be accomplished by use of the orbiter PI link or an S-Band link with an operational TDRS. Five telemetry dipouts are provided during the transfer orbit. Confirmation of the TDRS appendage deployment and separation attitudes is provided by the AMS telemetry stream received by the Merritt Island or Bermuda groundstation. Confirmation of TDRS separation is transmitted in a similar manner.

TOS/AMS FLIGHT OPERATIONS OVERVIEW FOR TDRS
(TASK 3.1.13)

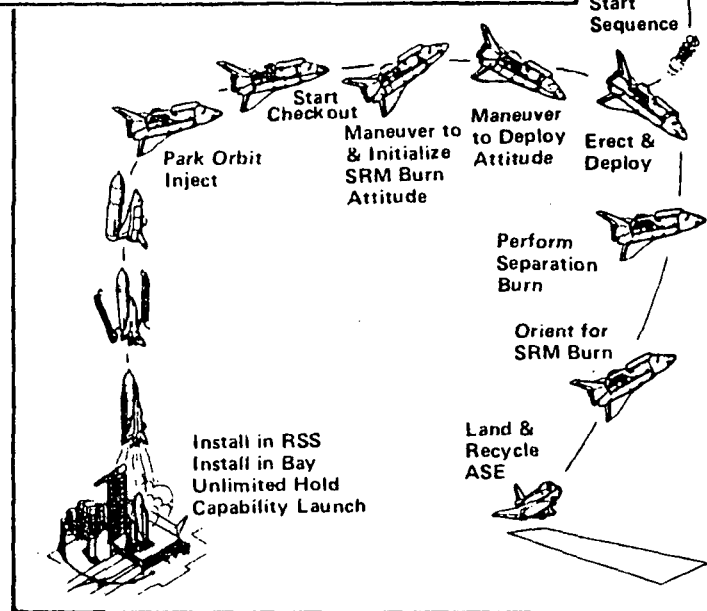
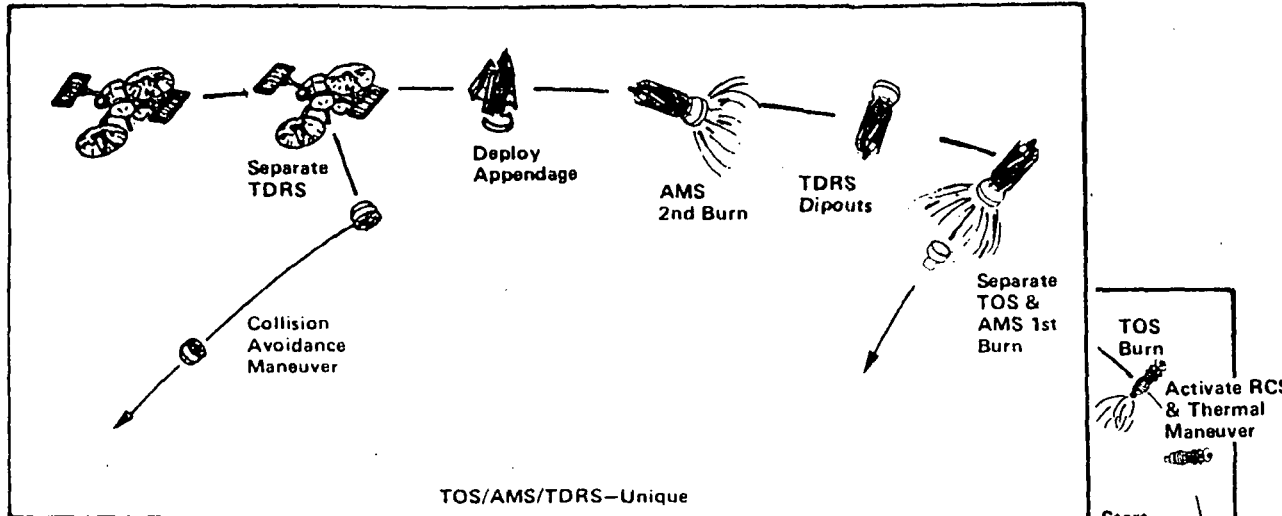

TOS/AMS TDRS FLIGHT OPERATIONS TIMELINE

The flight operations timeline is shown for the TOS/AMS/TDRS mission referenced to orbiter deployment. This timeline corresponds to the event sequences described on page 60 A of this report, and was used to establish power and RCS propellant requirements for the TDRS application. All TDRS-required maneuvers (thermal, telemetry, appendage deployment, and separation) are accommodated in this timeline.



MARTIN MARIETTA

TOS/AMS/TDRS FLIGHT OPERATIONS TIMELINE
(TASK 3.1.13)

Time* (hr:min:s)	Event	Time* (hr:min:s)	Event
- 2:00:00	Apply Power; Uplink Burn Parameter; Perform STS Rate-Matching Maneuvers	2:00:00	Initiate TDRS Dipout No. 1
- 1:00:00	Initialize Gyros; Continue TOS/AMS TDRS Predeployment Checkout	3:00:00	Initiate TDRS Dipout No. 2
- 0:28:00	Maneuver Orbiter to Deployment Attitude	4:00:00	Initiate TDRS Dipout No. 3
- 0:20:00	Elevate Cradle for Deployment	5:00:00	Initiate TDRS Dipout No. 4
0:00:00	Deploy TOS/AMS/TDRS	5:40:00	Initiate TDRS Dipout No. 5
0:10:00	Safe Separation Distance (200 ft min); Telemetry Activation	5:52:55	Orient for Apogee Burn
0:10:20	RCS Activation	5:55:40	AMS Second Burn Ignition
0:12:00	Begin Thermal Maneuvers; Orbiter Maneuver to OMS Burn Attitude	6:21:00	Maneuver for TDRS Appendage Deployment
0:19:00	Orbiter OMS Separation Burn	6:28:00	Maneuver for TDRS Communication
0:39:00	Orbiter Maneuver for TOS Burn	6:55:00	Maneuver to TDRS Separation Attitude
0:45:06	Ignite TOS SRM	6:55:32	Separate TDRS from AMS
0:47:43	Separate TOS from AMS/TDRS	6:56:00	AMS Initiate Collision Avoidance Maneuvers
0:47:53	AMS First Burn Ignition	6:58:00	AMS Collision Avoidance RCS Burn
0:51:00	Begin Thermal Maneuvers	7:01:00	AMS Maneuver for T/M Downlink
		7:05:00	AMS Maneuver for Depletion Burn
		7:06:00	AMS Initiate Depletion Burn

*Time Referenced to TOS/AMS/TDRS Deployment from Orbiter

TOS/AMS GROUND SUPPORT INTERFACES FOR TDRS

The TOS/AMS/TDRS ground system support interfaces are shown. The conduct of the TOS/AMS/TDRS flight operations will be supported by a combination of NASA and contractor facilities, systems, and personnel. Activities will center around the operational and management team of TOS/AMS personnel located at JSC working in the STS flight operations environment. Another team of personnel located at Martin Marietta Denver Aerospace will complete the TOS/AMS operations support staff. Spacecraft-specific operations for the TDRS mission will be supported from White Sands Ground Terminal (WSGT).

JSC payload operations for the TOS/AMS/TDRS mission will be the responsibility of the payload officer in the mission operations control room (MOCR). TOS/AMS operations activities and management coordination will occur in the JSC payload MPSR and the customer support room (CSR), respectively. The MPSR will have console facilities allowing display of selected STS data and TOS/AMS data.

A team of four Martin Marietta engineers will staff consoles in the MPSR and will act as the point of contact for the payload officer and the TOS/AMS program management team in the CSR for all TOS/AMS operations during the mission. The support and management teams will support the TDRS mission from prelaunch through AMS deactivation. The TOS/AMS program management team will coordinate all TOS/AMS programmatic and management decisions with the TDRS program manager and the STS payload integration manager (PIM), and will consist of OSC, Martin Marietta, and MSFC personnel. TOS/AMS and TDRS personnel in the CSR will be able to view selected orbiter data as well as TOS/AMS data.

TOS/AMS GROUND SYSTEM SUPPORT INTERFACES FOR TDRS
(TASK 3.1.13)

Osc

MARTIN MARIETTA

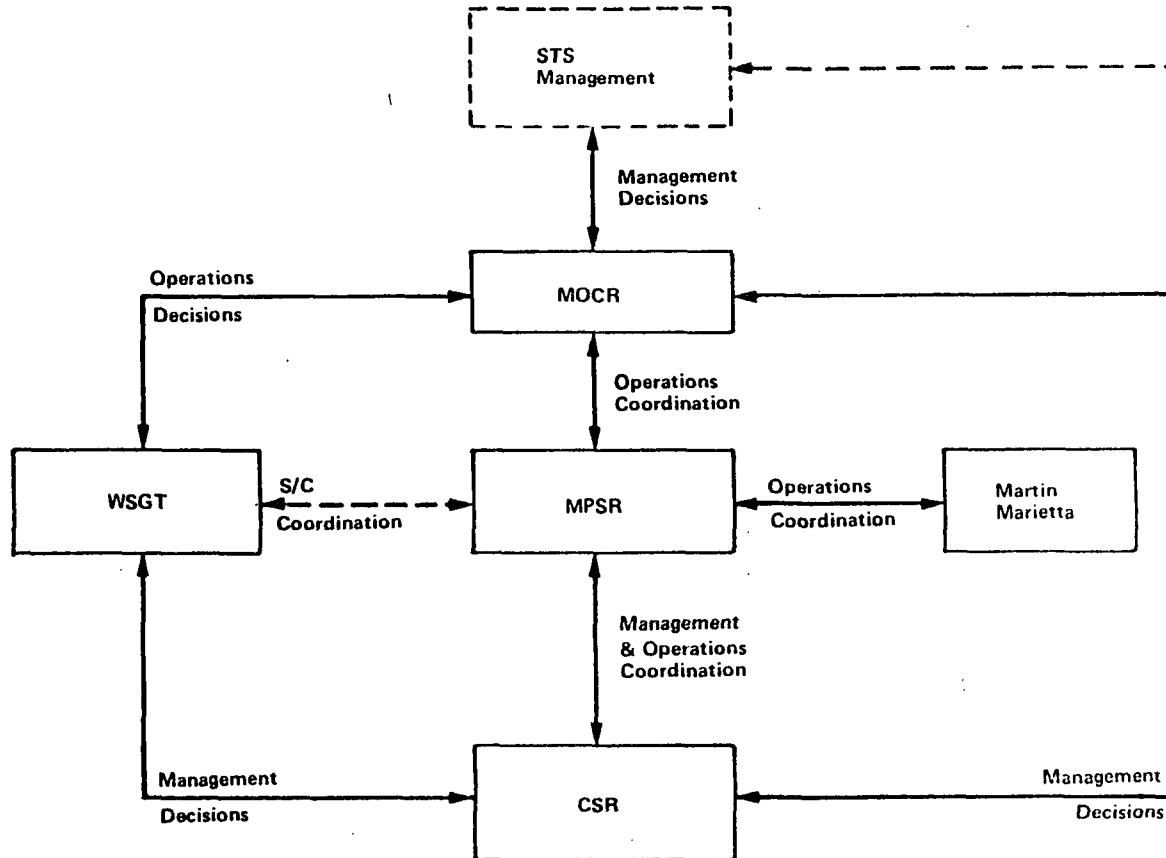

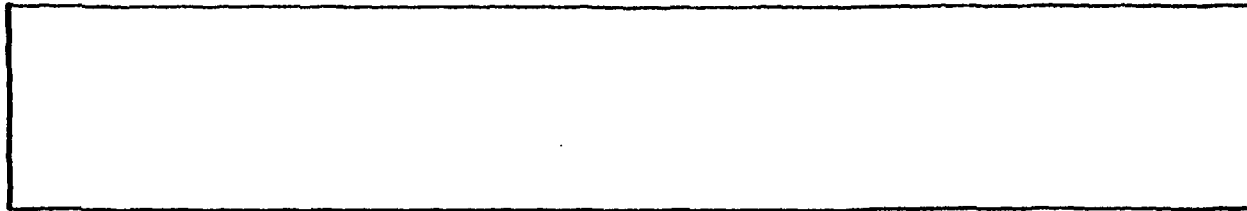

QSC

MARTIN MARIETTA

4.0 ACCURACY ASSESSMENT AND AVIONICS

TDRS UNIQUE REQUIREMENTS - AVIONICS

TDRS unique orbital requirements dictate accurate guidance to satisfy previously defined injection accuracy. On-orbit initialization, instrument and timing errors must be constrained to satisfy this accuracy.

The lower TDRS RCS tank presents a slosh concern for stability because it is partially loaded and a control authority concern because of its CG uncertainty that results from bladder deformation. The control system must also provide a 3 deg/sec roll for TDRS thermal control during periods of extended coast. A low rate limit cycle is necessary to minimize structural concerns during TDRS appendage deployment.

A power kit is required to supply approximately 600 watts of 28 VDC power from liftoff to TDRS separation. Because TDRS antennas are not deployed until after separation from the TOS/AMS, its communications capability must be supplemented.

The TOS/AMS must be compatible with all TDRS electrical interfaces to eliminate any requirement for TDRS redesign or retest.

TDRS UNIQUE REQUIREMENTS - AVIONICS

OSC

MARTIN MARIETTA

- o ACCURATE ORBIT INJECTION
- o 3 DEGREE PER SECOND THERMAL ROLL
- o OFFSET PROPELLANT CG
- o 1000# PROPELLANT (SLOSH)
- o KITS TO SATISFY:
 - POWER, 28VDC
 - TELEMETRY, COMMAND
- o LOW RATE LIMIT CYCLE FOR APPENDAGE DEPLOYMENT
- o COMPATIBILITY WITH TDRS ELECTRICAL INTERFACES

0112G-10-RS

TOS/AMS AVIONICS SUBSYSTEM BLOCK DIAGRAM

The baseline TOS/AMS avionics as shown on the facing page can be subdivided into the following functional subsystems:

- a) Guidance and Control
- b) Event Sequencing
- c) Electrical Power System

The guidance and control (G&C) equipment provides preprogrammed guidance for TOS/AMS maneuvers and three axis control during powered and coast flight. It consists of redundant Ring Laser Gyro (RLG)/Computers operating in the prime/backup mode, and an Input/Output Unit that interfaces the RLG Computer with the AMS TVC actuators and RCS thrusters and the TOS SRM TVC System. SRM TVC Control is redundant using two electronic controllers to drive redundant motors within the engine actuators. Separate feedback potentiometers monitor the position of the engine thrust chamber to minimize cross coupling. The Input/Output Unit includes the servo electronics to position the main engine actuators and provides on/off power switching of the RCS thruster valves.

The event sequencing hardware includes a majority vote sequencer (MVS) that issues mission discrettes timed from deployment, pyro initiator controllers (PICs) for firing the propulsion and separation ordnance, and a relay assembly to address the firing currents to the desired ordnance device. MVS discrettes also provide mode control for the G&C System. The design satisfies STS safety requirements (NHB 1700.7) for three electrical inhibits and provides the reliability necessary for mission success.

The electrical power subsystem is made up of redundant silver-zinc batteries controlled by highly reliable motor driven switches with the appropriate diode isolation.

TOS/AMS AVIONICS SUBSYSTEM BLOCK DIAGRAM

QSC

MARTIN MARIETTA

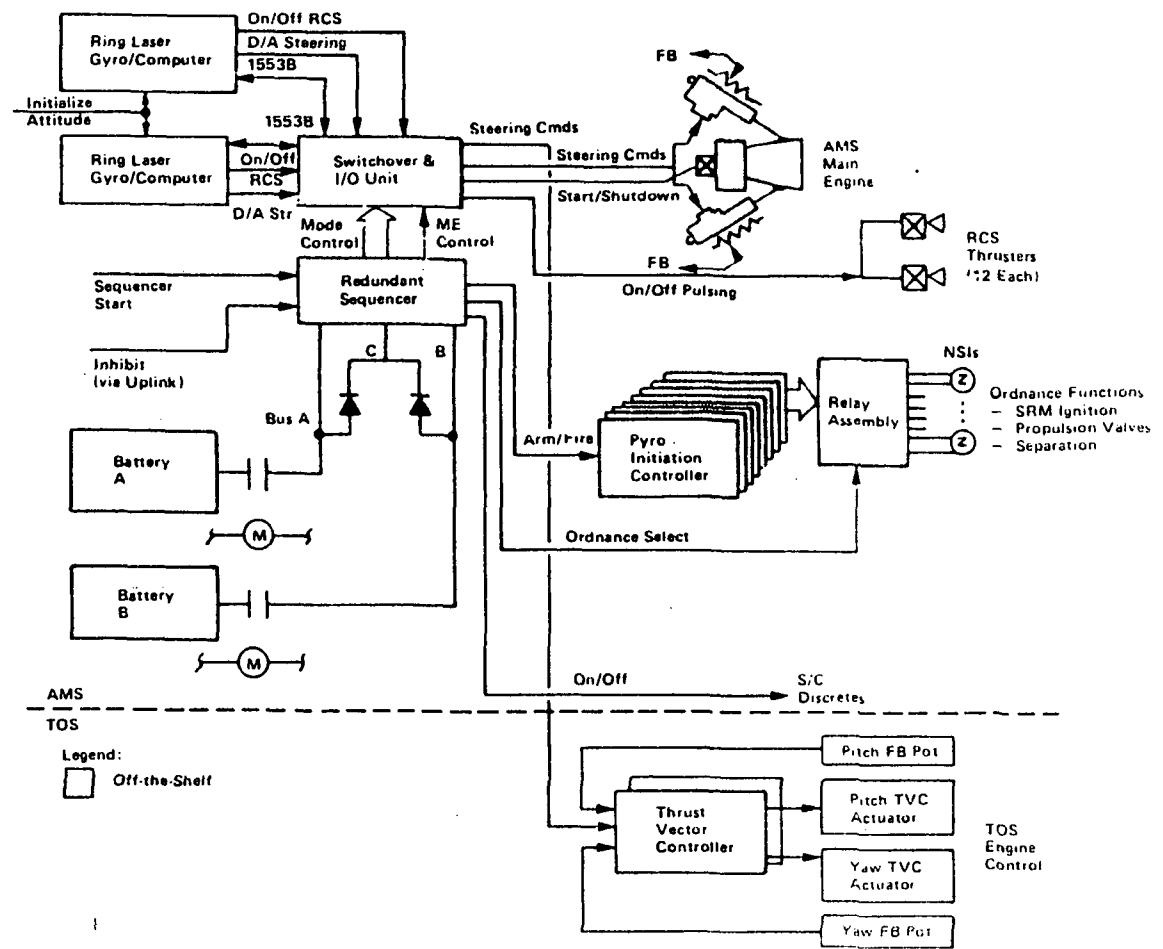

TOS/AMS/TDRS AVIONICS HERITAGE

The Honeywell H700-3 Ring Laser Gyro (RLG)/Computer has evolved from tactical and re-entry missile in addition to commercial aircraft programs. Switchover from prime to backup is controlled by Built-In-Test (BIT) within the units.

The Input/Output Unit will be derived from a TOS equivalent that is similar to a unit developed on a classified program. The TOS/AMS unit will include velocity control, cross axis steering, and close the loop around the AMS main engine actuator. For TDRS using the IUS cradle command decoding will be included to generate inhibit discrettes to the MVS. The Majority Vote Sequencer is identical to that being developed on the TOS program. The capacitive discharge Pyro Initiator Controller (PIC) boards have been used by the thousands for ordnance firing on the shuttle. They will be packaged in units of four for the TOS and used unchanged for TOS/AMS.

The Martin manufactured Relay Assembly has been used for more than 10 years on the Titan program. It consists of twenty Babcock 10 amp DPDT relays with appropriate suppression.

The Eagle Picher 175 AH silver-zinc battery has flown on Titan Transtage for more than 10 years.

Motor driven switches made by Teledyne, flight proven on IUS, and used on TOS will control power application on the TOS/AMS. Titan diode assemblies will provide isolation and suppression.

Umbilicals manufactured for the IUS by Gray/Huleguard will be used to be compatible with IUS cradle mechanisms.

TOS/AMS/TDRS AVIONICS HERITAGE

QSC

MARTIN MARIETTA

<u>QUANT</u>	<u>DESCRIPTION</u>	<u>HERITAGE</u>
2	RING LASER GYRO/COMPUTER	TOS (TACTICAL MISSILES) (COMMERCIAL A/C)
1	INPUT/OUTPUT UNIT	NEW (SIMILAR TO CLASSIFIED UNIT)
1	MAJORITY VOTE SEQUENCER	TOS (SIMILAR TO MV SWITCH)
6	PIC BOX	SHUTTLE/TOS
1	RELAY ASSEMBLY	TITAN
2	BATTERY-175 AH	TITAN
3	MOTOR DRIVEN SWITCH	IUS/TOS
4	DIODE ASSEMBLY	TITAN
2	UMBILICAL CONNECTORS	IUS

0112G-14-RS

TOS/AMS AVIONICS RELIABILITY

The Ring Laser Gyro (RLG) has been under development for twenty years and is flying large numbers on military and commercial aircraft. Numerous RLGs have flown successfully on tactical missile and reentry vehicles. Gyro MTBF's is currently on the order of 50,000 hours. The Honeywell H700-3 unit, used on TOS/AMS has a 90% built in test (BIT) that monitors internal health and will switch to the backup unit upon detecting a failure. Computation is internal to the unit with compatible microprocessor based computers for instrument compensation/transformation and another computer for guidance and controls.

The SRM TVC incorporates a switchover identical to that used for IUS. Detection of an excessive error signal at the prime servo input will switch to the backup unit.

The RCS drivers have been made fail safe by incorporating series power transistors for thruster valve switching.

The majority vote sequencer (MVS), derived directly from the TOS program, provides mission success and satisfies Shuttle safety. The PICs are armed shortly prior to ordnance firing and will only operate in a specified sequence.

The TOS/AMS mission can be performed on only one of the two batteries while retaining a substantial power margin

TOS/AMS AVIONICS RELIABILITY

QSC

MARTIN MARIETTA

- o RING LASER GYRO IS MATURE , RELIABLE AND HAS LARGE PRODUCTION BASE
- o INSTRUMENT COMPENSATION / G&C COMPUTATIONS INTEGRAL TO RLG UNIT
- o PRIME/BACKUP CONFIGURATION SWITCHES ON BUILT IN TEST (BIT)
 - BIT COVERAGE IS 90 - 95%
 - SEU MITIGATED WITH COMBINATION OF HARDWARE AND SOFTWARE
- o TOS TVC REDUNDANCY (SWITCHOVER) SAME AS IUS
- o RCS DRIVER DESIGN IS FAIL SAFE (PARALLEL THRUSTER CONTINUES OPERATING)
- o TOS SEQUENCER IS TMR FOR MISSION SUCCESS AS WELL AS SAFETY
- o PYRO INITIATOR CONTROLLERS DERIVED FROM SHUTTLE
- o PARALLEL BATTERIES AND POWER CONTROL PROVIDE MARGIN AND REDUNDANCY

GUIDANCE AND CONTROL SELECTION TRADES

TOS/AMS Guidance and Control (G&C) requirements include simplicity, accurate orbital placement, three-axis stabilization, high reliability, low cost and an eight hour on-orbit mission duration.

For flexibility and simplicity TOS/AMS guidance should be initialized on-orbit in order to allow extended holds in the Orbiter payload bay. TDRS accuracy must be satisfied in the most cost-effective manner. Growth capability for accuracy improvements and new operating modes should also be provided.

A primary stabilization criteria is for control authority in the presence of mass uncertainties and other disturbances. The control design must be capable of achieving low limit cycle rates to minimize TDRS loads during appendage deployment as well as minimize propellant consumption. There is an obvious criteria of low weight and power where power also translates into weight because the mission is powered from batteries.

Reliability is a vital factor in system design. There is a trade off between a highly reliable proven single string design and a fault tolerant system. Fault tolerance always dictates redundancy which contradicts the criteria for low weight and power. A switchover can overcome single point failures but may necessitate redundancy management software. A majority vote or triple modular redundant (TMR) design is a straight forward approach that avoids software complexity, but has the largest weight and power penalty.

Computer timing and sizing are driven by software complexity. Cost is a direct function of memory size and increases as throughput approaches processing capability. A modular computer architecture and software design allows adding functions with minimum cost impact. The cosmic particle environment at AMS altitudes and longer mission time aggravates the single event upset (SEU) problem. Reducing the probability of SEUs through a combination of hardware and software designs is mandatory for mission success.

GUIDANCE AND CONTROL SELECTION TRADES

OSC

MARTIN MARIETTA

CRITERIA

- o GUIDANCE
 - ON ORBIT INITIALIZATION
 - SATISFY TDRS ACCURACY
 - GROWTH CAPABILITY
- o CONTROL SYSTEM PERFORMANCE
 - CONTROL AUTHORITY MARGIN
 - LOW LIMIT CYCLE RATES
 - MINIMIZE PROPELLANT CONSUMPTION
- o LOW WEIGHT AND POWER
- o FAULT TOLERANT OPTIONS
 - HI REL SINGLE STRING
 - PRIME/BACKUP
 - MAJORITY VOTE
- o COMPUTATION
 - MANAGEABLE SIZING AND TIMING
 - FLEXIBLE ARCHITECTURE
 - SEU PROTECTION

0112G-7-RS

CANDIDATE GUIDANCE SYSTEMS - TASK 3.1.2

To arrive at our TDRS guidance baseline three configurations were traded off to compare their orbit insertion accuracy: a simplified guidance concept with spinning mass gyros, a simplified concept with RLGs, and a full-up guidance and navigation system. The simplified concepts, based on preprogrammed burns, were emphasized for their low cost. Their performance evaluated using a TOS/AMS scenario. The objective of this comparison was to ascertain what an RLG's improved (versus spinning mass gyros) drift rate stability and substantially lower scale factor uncertainty could do for geostationary orbit accuracy.

The spinning mass example, used for performance evaluation was the flight proven Singer Kearfott SKIRU III. The SKIRU gyros are identical the those used for Voyager and in the Shuttle IMU's. They are Dry Tuned Gyros that require long warm up times and substantial calibration for maximum performance.

Performance of the Honeywell H700-3 Strapdown Ring Laser Gyro (RLG) was compared with the SKIRU. Ring laser gyros have been in development for 20 years and have flown on both missiles and aircraft. RLG performance is very stable and has exceptionally low drift and scale factor errors.

The Transtage gimballed platform guidance and navigation system was evaluated as the third configuration because it is an "off the shelf" system designed for a GSO mission. It also provides a valid basis of comparison between preprogrammed guidance and full-up inertial guidance.

CANDIDATE GUIDANCE SYSTEMS - TASK 3.1.2



TYPE	EXAMPLE	CHARACTERISTICS
SPINNING-MASS GYRO STRAPDOWN	SINGER-KEARFOTT SKIRU - III	- EXTENSIVE CALIBRATION REQUIRED - LONG WARM-UP + TEMP. CONTROL
RING-LASER GYRO STRAPDOWN	HONEYWELL H-700-3 (GG-1328 GYROS)	- AIRCRAFT AND MISSILE USAGE - LOW DRIFT RATE AND SCALE FACTOR - PERFORMANCE GROWTH POTENTIAL
ALL INERTIAL GUIDANCE & NAVIGATION SYSTEM	DELCO CAROUSEL (TRANSTAGE)	- SPACE-PROVEN GIMBALLED PLATFORM - DEMONSTRATED CLOSED-LOOP ACCURACY - HEAVY/POWER-CONSUMPTION

0112G-8-RS

GUIDANCE ACCURACY ASSESSMENT (WORST CASE ANALYSIS)

In order to derive the baseline guidance system performance of the two preprogrammed guidance designs previously identified was used to assess injection accuracy. SKIRU III and RLG gyro error accumulation was derived and compared using identical mission timelines. These concepts were evaluated to ascertain what accuracy these instruments would provide in the AMS geostationary mission scenario and how much accuracy would be improved with the lower bias stability ;and scale factor of the RLG. This preprogrammed guidance incorporated pre-stored burn and maneuver attitudes and times.

The figure illustrates the six cases used in this accuracy assessment. The RLG was evaluated with both nominal and enhanced error budgets where the enhanced would require instrument selection and/or a modified final assembly procedure. Accelerometer performance was not a major driver. Case 6 used a star tracker to update attitude prior to the burns. The analysis showed that the stellar update dominated gyro performance at apogee.

Two basic techniques were evaluated for on-orbit alignment and initialization in the shuttle bay. The first was a coarse align, essentially accepting the Orbiter guaranteed 1.0 degree (maximum) pointing uncertainty between their navigation base and the Payload bay trunnions. The second technique, termed transfer alignment (or rate matching), requires Orbiter maneuvers to measure and estimate the relative misalignment between Orbiter and AMS gyro axes. Our assessment assumed 0.2 degree three sigma per axis which is about mid-range of the expected transfer alignment capability. Our worst case analysis placed all pointing errors in the yaw (out of plane) direction and showed that gyro drift error dominates when it exceeds 0.2 deg/hour.

GUIDANCE ACCURACY ASSESSMENT (WORST-CASE ANALYSIS)



MARTIN MARIETTA

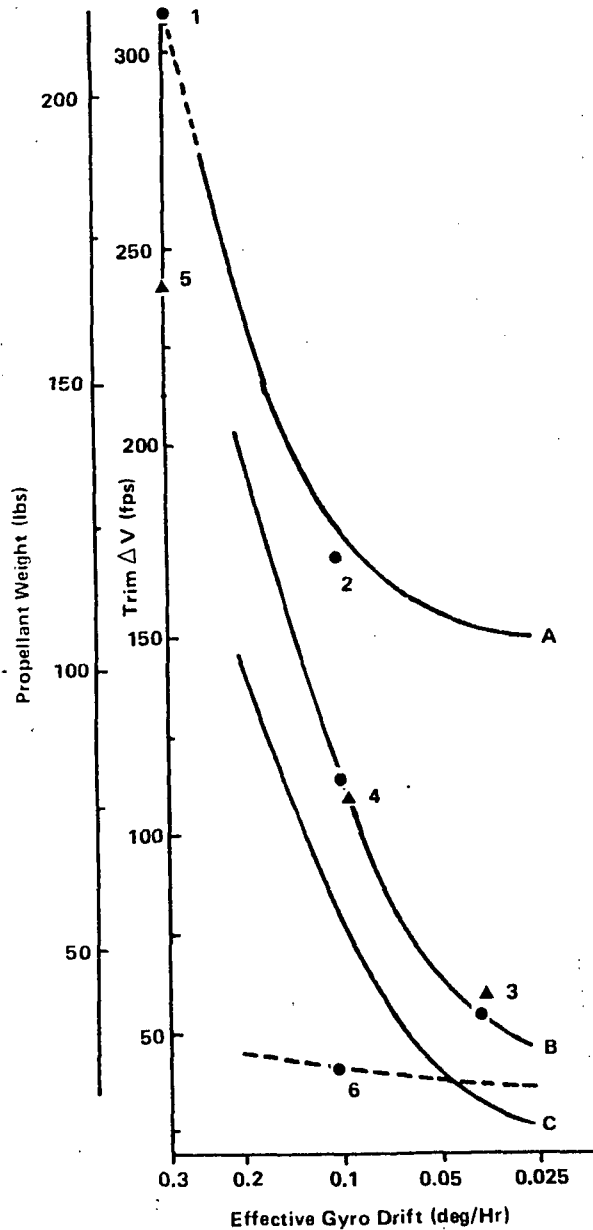

Legend:	
- Spacecraft ΔV & Hydrazine Required to Trim Final Orbit (Correcting All Errors: a, i, e) (WT_0 - 5000 lbs, ISP - 220 s)	
- Approximate Trend Data (All CG Trim)	
- Guidance Update at Apogee	
A	1. deg Handoff, 0.1% Accelerometer
B	0.2 deg Handoff, 0.05% Accelerometer
C	0.2 deg Handoff, 0.1% Accelerometer
- Data from Gyro Vendors Using TDRS Ref Mission Timeline†	
Case No.	
1	SKIRU-III, 1. deg Handoff
2	RLG, 1. deg Handoff, Nominal Error Model
3	RLG, 0.2 deg Handoff (Rate Matching), Enhanced Error Model
4	RLG, 0.2 deg Handoff (Rate Matching), Nominal Error Model
5	SKIRU-III 0.2 deg Handoff (Rate Matching)
6	RLG, 1. deg Handoff, Nominal Error Model, ST Updates (0.1 deg) Before Each Burn

Note:

† Worst-Case Yaw Errors (●), Worst Case 3-Axis (▲)
Realistically-Distributed Errors

GUIDANCE ACCURACY TRADE STUDIES - SUMMARY TASK 3.1.2

The facing table summarizes the results of the guidance accuracy assessment from the previous page. This summary includes performance of the SKIRU III spinning mass gyro as well as both the nominal and enhanced ring laser gyros (RLGs).

Two on-orbit attitude alignment accurancies are tabulated; (1) the normal 1.0 degree Orbiter hand off; and (2) a 0.2 degree alignment that is available using special maneuvers for "rate matching".

Spacecraft propellant requirements (in lbs) to trim out the respective orbital dispersions are listed along with the resulting delta V apogee errors.

The analyses indicate that RLG performance is necessary to achieve acceptable velocity errors and low make up propellant. Performance of the enhanced RLG with the 0.2 degree alignment compares favorably with more sophisticated guidance systems.

GUIDANCE ACCURACY TRADE STUDIES - SUMMARY TASK 3.1.2



- TRIM ΔV AND PROPELLANT WEIGHT REQUIRED TO CORRECT ALL DISPERSIONS AT APOGEE

ΔV (FPS)/ ΔW_T (LBS)

SKIRU - III		RLG (HI-GG1328)			
NOMINAL ERROR SOURCES		NOMINAL ERROR SOURCES		"ENHANCED" ERROR SOURCES	
NOMINAL ORBITER HANDOFF (1)	TRANSFER ALIGNMENT (2)	NORMAL ORBITER HANDOFF (1)	TRANSFER ALIGNMENT (2)	NORMAL ORBITER HANDOFF (1)	TRANSFER ALIGNMENT (2)
310 FPS 224. LBS	240. 172.	170. 122.	115. 82.	CASE NOT RUN	68. 48.

(1) 1.0 DEG 3σ (TOTAL)

(2) 0.2 DEG 3σ (PER AXIS) ~ "RATE MATCHING"

GUIDANCE ACCURACY VERIFICATION (MONTE CARLO COMPARISON)

Monte Carlo analysis of the TOS/AMS geosynchronous transfer accuracies was performed on three candidate avionics configurations to validate the worst case parameteric results. The three gyro package configurations evaluated were:

1. Singer Kearfott 2-DOF, SKIRU-III;
2. Honeywell nominal ring laser gyro (RLG); and
3. Honeywell enhanced RLG.

The Monte Carlo approach takes N passes through a randomization and trajectory propagation package, ending with final orbit error evaluation software. N was chosen to yield significance to the 3 sigma level (.9987) by using a value of 400 cycles.

The basic random variables used in the program include vehicle dynamics parameters which are a function of manufacturing tolerances, loading accuracies, etc. and avionics errors such as on-board clock errors, gyro and accelerometer instrument errors, as well as orbiter deployment errors. In all cases, independent Gaussian distributions were assumed.

Rocket burns are modelled as a 200 point thrust/flowrate table for the TOS solid motor burn (which includes tailoff) and as a constant thrust/flowrate for the AMS liquid motor burn. A prototype TOS/AMS control logic was used to perform whatever sequence of burns the mission profile requires. Instrument errors are modelled as follows:

1. Initialization misalignment (in pitch, yaw and roll) is translated into an attitude transformation matrix.
2. The matrix is post-multiplied by a second attitude matrix derived from pitch, yaw, and roll gyro drifts at burn times to establish a net attitude error matrix.
3. At a fixed time after ignition, a closed loop steering function trims the instrument derived acceleration vector to the desired ignition pointing vector.
4. AMS cutoff is computed in a time-to-go routine using the accelerometer model.

Once the trajectory propagation is complete, a velocity trim routine is used to determine the spacecraft delta V required to achieve the desired final orbit. In all cases, spacecraft propellant requirements are computed based on weight and I_{sp} .

As indicated in the figure the Monte Carlo results were the same or slightly improved over the initial worst-case trajectory analyses. These runs verified the overall guidance accuracy results.

GUIDANCE ACCURACY VERIFICATION (MONTE CARLO COMPARISON)

OSC

MARTIN MARIETTA

PARAMETER GUIDANCE CONFIGURATIONS (2)	TRIM ΔV AND PROPELLANT WEIGHT REQUIRED TO CORRECT ALL DISPERSIONS AT APOGEE (1) ΔV (FPS) / ΔW_T (LBS)	
	MONTE CARLO (3 σ)	WORST-CASE
SPINNING MASS DTG (SKIRU III)	210. (FPS)	240.
	150. (LBS)	172.
RLG (NOMINAL)	105.	115.
	71.	82.
RLG (ENHANCED)	66.	68.
	46.	48.

(1) TRANSFER ALIGNMENT PERFORMED IN ALL CASES
(0.2 DEG/AXIS, 3 σ)

(2) DELCO CAROUSEL (TRANSTAGE) PERFORMANCE: $\Delta V = 58.$ FPS
 $\Delta W_T = 42.$ LBS

CONTROL SYSTEM TRADES AND ANALYSES - TASK 3.1.6

Two categories of trades and analyses were performed to define the TOS/AMS propulsion configuration.

Trades were conducted to compare fixed versus gimballed main engines to establish the control margins available. Use of RCS only control, can be simple but may be marginal in control authority and use substantial RCS propellants. CG offsets effects were also evaluated to establish their impact on control authority.

Sizing of the RCS thrusters was a major study effort that interplayed with the fixed main engine studies. The more simple blowdown systems were compared with regulated designs. Redundancy in RCS valves and engine configuration was also considered. Propellant consumption is a major factor in sizing RCS thrusters.

QSC

MARTIN MARIETTA

CONTROL SYSTEM TRADES AND ANALYSES - TASK 3.1.6

o POWERED FLIGHT

- FIXED vs GIMBALLED MAIN ENGINE (RCS vs TVC)
- MOMENT BALANCE (GIMBAL ANGLE vs CG OFFSET)
- LATERAL STEERING TO MINIMIZE CG OFFSET EFFECTS

o COASTING FLIGHT - RCS

- THRUST LEVEL SELECTION (5 TO 30 LBF)
- REGULATED vs BLOWDOWN PROPELLANT FLOW
- REDUNDANCY
- CONTAMINATION
- PROPELLANT CONSUMPTION

0112G-12-RS

TDRS IMPACTS ON CONTROL SYSTEM DESIGN - TASK 3.1.6

The ACS must be able to provide thermal roll capability at 3 deg/sec while holding pitch and yaw within a specified attitude deadband.

There is a requirement for a fine-pointing attitude control mode with a deadband of ± 0.5 deg in roll, pitch and yaw, with rates at ± 0.2 deg/sec in pitch and yaw and ± 0.5 deg/sec in roll and a coarse mode attitude deadband of from ± 2.0 to 5.0 deg in all three axes. In addition, provisions must be made for minimum impulse operation during TDRS appendage deployment corresponding to a minimum roll rate of 0.3 deg/sec and maximum pitch/yaw rates of 0.1 deg/sec.

There is a requirement for a vernier velocity mode to settle main engine propellants prior to AMS ignition and perform collision avoidance maneuvers after TDRS separation.

During powered flight, full 3-axis stability and control is required in the presence of flexible-body effects, sensor noise, as well as propellant slosh, and significant cg offsets that result from the large TDRS propellant mass.

The control system must accommodate maneuvering for telemetry dipouts for TDRS communications. Maneuver rates must be established and RCS propellant allocated.

TDRS IMPACTS ON CONTROL SYSTEM DESIGN - TASK 3.1.6

Osc

MARTIN MARIETTA

- o THERMAL ROLL (3 DEG/SEC)
- o MINIMUM IMPULSE DURING TDRS APPENDAGE DEPLOYMENT (0.1 DEG/SEC ROLL & 0.3 DEG/SEC P & Y)
- o COLLISION AVOIDANCE
- o FLEXIBLE-BODY AND SLOSH DYNAMICS EFFECTS
- o LARGE TDRS PROPELLANT CG-OFFSET UNCERTAINTY
- o TDRS TELEMETRY DIPOUTS

CONTROL SYSTEM RESULTS - TASK 3.1.6

The half-loaded TDRS aft fuel tank and stiffness of the bladder material results in an unpredictable but permanent "shift" of the fuel mass that results in a significant cg offset (4.8 inches for the tank alone) that is reflected in the total vehicle cg. For this reason special attention was directed to investigating control authority. Studies were conducted to investigate both fixed and gimballed main engine configurations. Axially fixed engines require that powered flight attitude control rests solely on the RCS. Using an RCS blowdown system, pitch and yaw control authority was determined to be inadequate during the latter portions of the second AMS main engine burn. The baseline 2650-lbf, gimballed liquid propellant engine was selected because it had a gimbal angle capability of 5° and could accommodate a total TOS/AMS/TDRS vehicle cg offset as large as approximately 3 inches, as shown in the figure.

Coast Flight Control is achieved using 12 RCS thrusters arranged as shown in the lower figure. Based on control capability, availability of qualified hardware and cost, IUS rocket engine modules (REMs) consisting of a pair of 30 lbf thrusters in a blowdown configuration were selected. This configuration achieves minimum contamination, demonstrated redundancy, full rotational control, and X-axis translational capability. The blowdown system, besides being the most cost effective, has a low rate capability which is an advantage for the TDRS or similar missions. TDRS appendages require low acceleration levels during the deployment phase just before AMS-TDRS separation to avoid exceeding the structural load capability of the hinge points. The rate and acceleration levels for the systems studied were extrapolated to evaluate the blowdown levels for both a single engine and two engines firing as a pair. The rates achievable with the blowdown configuration are easily met, particularly in the case of a single engine firing for a single 10 ms pulse. The TOS/AMS thruster configuration is fault tolerant in that a single thruster will fail safe. The second thruster of the pair will continue to operate and allow mission completion.

CONTROL SYSTEM - RESULTS TASK 3.1.6



MARTIN MARIETTA

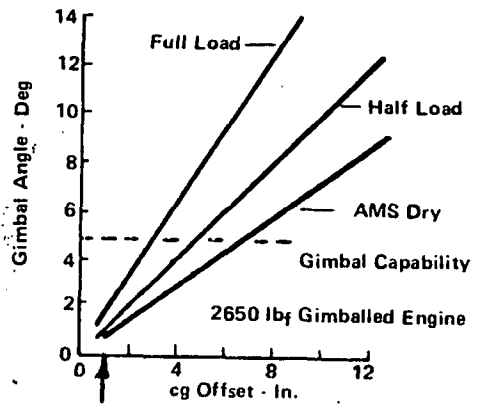

RCS ONLY CONTROL INADEQUATE
 GIMBALLED ENGINE MINIMIZES RCS CONSUMPTION
 EXCELLENT CONTROL AUTHORITY

RCS LAYOUT IDENTICAL TO IUS
 BLOWDOWN DESIGN MINIMIZES RATES
 SERIES/PARALLEL REDUNDANCY

View	Main Engine Nozzle	RCS Nozzles Fired	Resulting Motion (Aft-Looking Forward)	Resulting Body Rate
View Looking Forward		3, 9	Roll CW	+P (+ ϕ)
		6, 12	Roll CCW	-P (- ϕ)
		1, 2	Pitch Up	+q (+ θ)
		7, 8	Pitch Down	-q (- θ)
		4, 5	Yaw Right	+r (+ ψ)
		10, 11	Yaw Left	-r (- ψ)
		1, 2, 4, 5, 7, 8, 10, 11	Vernier ΔV	+ \dot{x}

COAST ATTITUDE CONTROL SYSTEM PHASE PLANE - TASK 3.1.6

The TOS/AMS coast attitude control design provides on/off valve driver commands for the reaction control jets, either singly or in pairs. Commands are based on attitude error and filtered attitude rate information. Overall, attitude control is maintained by tailoring the phase plane logic to satisfy mission requirements. Acceleration gain states convert attitude error and attitude rate information into appropriate RCS command impulses. These acceleration gain states are used to define the switching lines and regions in the roll, pitch, and yaw phase planes, which in turn determine RCS thruster commands for the current attitude error and attitude rate.

The general phase plane is shown in the figure. This phase plane logic was selected for its minimum convergence time, low limit cycle rate and low RCS propellant consumption. The software required to implement this logic is somewhat less than required for a previous Transtage design.

COAST ATTITUDE CONTROL SYSTEM PHASE PLANE - TASK 3.1.6



ADVANTAGES

- o MINIMUM CONVERGENCE TIME
- o LOW LIMIT CYCLE RATE
- o LOW PROPELLANT CONSUMPTION
- o MINIMUM SOFTWARE TO DEFINE

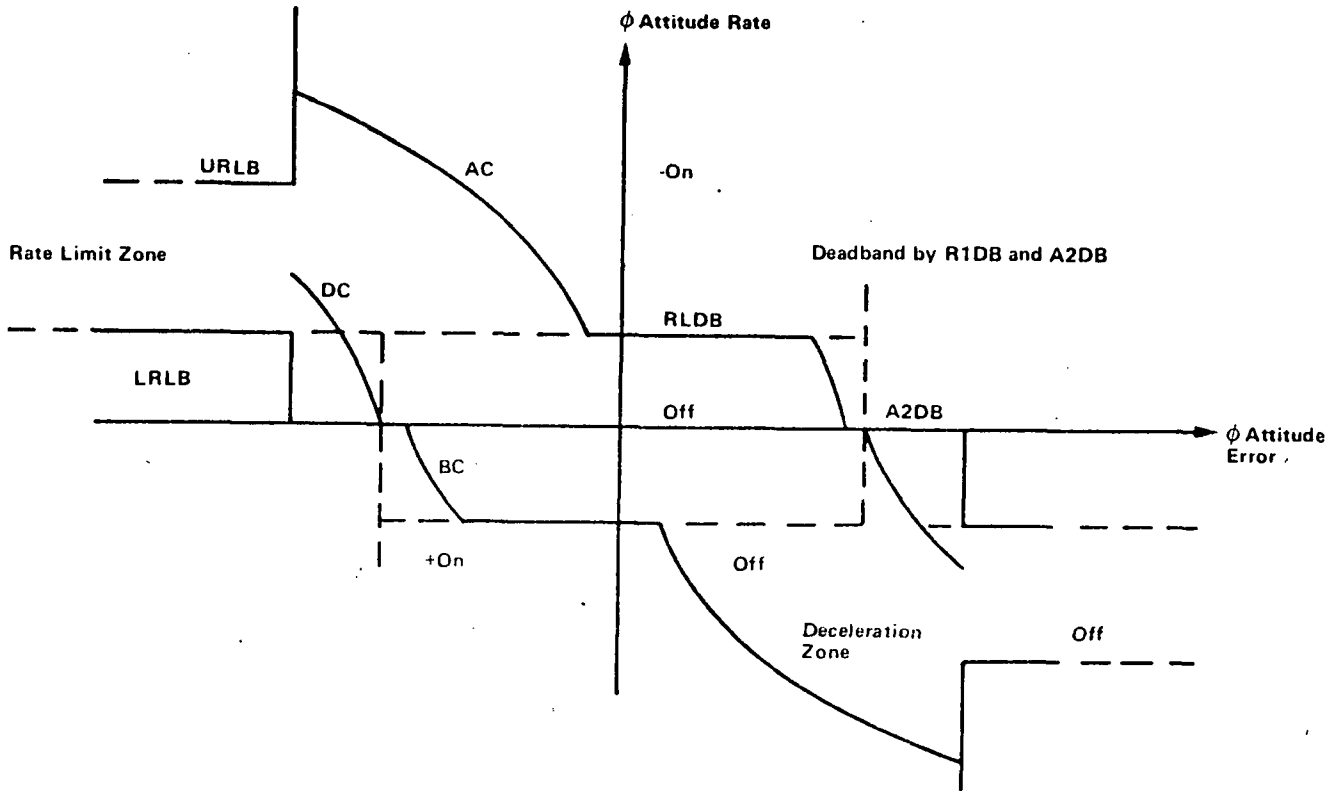

COMPUTER SINGLE EVENT UPSET (SEU) MITIGATION

There has been a recent concern with regard to the reliability of microcircuits in the presence of the single event upset (SEU) phenomena. SEU is not a hard failure but it can permanently invalidate the contents of a working register and cause a catastrophic computation error. For TOS/AMS/TDRS this is a concern because of mission duration, and because the stage must fly through a severe cosmic particle environment. Sensitivity to SEU is dependent upon microcircuit manufacturing technology and feature size. SEU concerns can be alleviated through a combination of upgrading the parts program and implementing the necessary software design procedures. Four effective hardware and software techniques are prevention, tolerance, detection, and shielding.

- 1) Prevention - Use SEU hardened circuits where appropriate devices are available. Bulk hardened CMOS and I³L technology are most immune. Large feature size microcircuits can be effective but incur a penalty in size, weight, and power consumption.
- 2) Tolerance - Use of added hardware and software;
 - a) Hardware majority voting and resynchronization; shadow random-access memory (RAM) or bank switching in RAM; error detection and correction logic where necessary.
 - b) Maximum use of PROM to prevent upset of program instructions and constants.
 - c) Software to repeat operations; use module to module handshaking; refresh latched peripherals routinely; design to minimize dependence on past RAM variables.
- 3) Detection - Software rollback to a known point upon SEU detection;
 - a) Hardware watchdog timer, illegal op code, illegal memory access compared (CPU) and peripherals;
 - b) Software reasonableness checks, handshaking.
- 4) Shielding - Selective use of shielding;
 - a) Stop protons only;
 - b) Good only in low-Earth orbit.

COMPUTER SINGLE EVENT UPSET (SEU) MITIGATION

OSC

MARTIN MARIETTA

- o SEU NOT HARD FAILURE, ONLY TRANSIENT BIT FLIP
- o SEU IS A FUNCTION OF THREE THINGS
 - MISSION DURATION
 - PARTICLE ENVIRONMENT
 - DEVICE CONSTRUCTION AND TECHNOLOGY
- o SEU IS MINIMIZED WITH GOOD SYSTEMS DESIGN
- o HARDWARE APPROACH
 - LESS VULNERABLE PARTS (CMOS, I²L, I³L)
 - MAXIMIZE FIXED MEMORY (PROM)
 - RAM ERROR DETECTION AND CORRECTION
 - WATCHDOG TIMER
- o SOFTWARE APPROACH
 - INTERRUPT DRIVEN
 - BUILT_IN TEST (BIT)
 - REASONABLENESS TESTS
 - TRIPLE COMPUTATION/STORAGE OF CRITICAL VARIABLES

SOFTWARE TIMING AND SIZING

The RLG/Computer has two integral microprocessor based computers. An Inertial Sensor Assembly (ISA) processor removes RLG dither, compensates, transforms and integrates instrument data. A G&C processor controls the preprogrammed guidance maneuvers and provides stability during powered and coasting flight.

Both micro computers are based on 16 bit Harris 80C86 bulk hardened CMOS microprocessors, operating with a co-processor to provide a 400 KOP throughput. Memory, which is a combination of PROM, E²PROM and RAM has been sized at 16000 16-bit words.

A worst-case software timing analysis was performed that showed a 48% powered flight margin and a 37% coast flight margin. This analysis was based on use of existing design logic and equations.

A detailed sizing analysis (see table) showed use of 8500 software locations out of the 16,000 for nearly 100% memory margin.

SOFTWARE TIMING AND SIZING

- o HARRIS 80C86 IS BASELINE MICROPROCESSOR
- o TIMING ANALYSIS BASED ON APPLICABLE IUS AND TRANSTAGE EQUATIONS
 - NEARLY 50% POWERED FLIGHT MARGIN
 - NEARLY 40% RCS COAST MARGIN
- o MEMORY SIZING BASED ON 16K OF 16 BIT
 - MAIN PROGRAM IN PROM, I-LOAD IN E²ROM
 - RAM IS EDC PROTECTED
 - NEARLY 100 % MEMORY MARGIN

Function	Size	Function	Size
Executive	1000	Attitude Control	3412
- Scheduling	(90)	- Sensor Processing	(404)
- Interrupt Process	(660)	- Attitude Quaternion	(126)
- Input/Output	(176)	- Thermal Control	(400)
- Utilities	(74)	- Error Quaternion	(67)
Test & Checkout	2850	- Attitude Rate Filter	(135)
- ASE Functions	(2700)	- Thrust Vector Control	(405)
- Telemetry	(150)	- Reaction Control	(1740)
Mission Data Load	600	- Lateral Steering	(90)
Random Access Memory	550	- Velocity Shutdown	(45)
Constants	55		
			Total 8467

TOS/AMS AVIONICS SEQUENCING DESIGN

The TOS/AMS electrical sequencing system is made up of a mission timer, ordnance firing circuits, and relay switching (see figure). Mission timing is controlled by the majority vote sequencer (MVS), which starts at physical separation from the ASE. MVS discrettes, buffered with internal relays, supply commands to the PIC ordnance firing circuits, G&C system, telemetry, TOS/AMS propulsion, and TDRS spacecraft.

The MVS is internally redundant and has two complete sets of three software-controlled independent microprocessor timers that are majority voted. Hardened 8085 microprocessors were used as timers because of their immunity to single-event upset. Majority voting prevents a single timer from inadvertently activating a safety critical (propulsion/ordnance) flight event. The voted discrete outputs, in conjunction with the MVS relays, provide at least three inhibits for each output event. For TDRS critical sequencer functions can be overridden via the command uplink in the event of an unsafe condition.

The ordnance firing system consists of six pyrotechnic initiator controller boxes, each containing four individual PIC circuits. The PIC is a capacitive discharge circuit that delivers energy to a standard 1-ohm pyro initiation device. The PIC is armed by charging its internal capacitor bank to 40 V. Upon receiving two independent fire signals (FIRE 1 and FIRE 2), the capacitors are discharged into the pyro device through transistor switches. The circuit is designed to be safe in preventing a premature output if a single component fails along with application of one fire signal. The PIC circuit has been extensively used on the Shuttle orbiter, solid rocket booster (SRB), and external tank.

The number of required PIC assemblies required has been reduced by multiplexing PIC outputs with relay switching. Switching the PIC outputs also introduces an additional firing inhibit. Each PIC output looks into two sets of independently controlled relay contacts to permit firing two separate pyro devices. The relays are packaged in an assembly that contains 20 4PDT, 10-amp relays and coil suppression diodes.

TOS/AMS AVIONICS SEQUENCING DESIGN

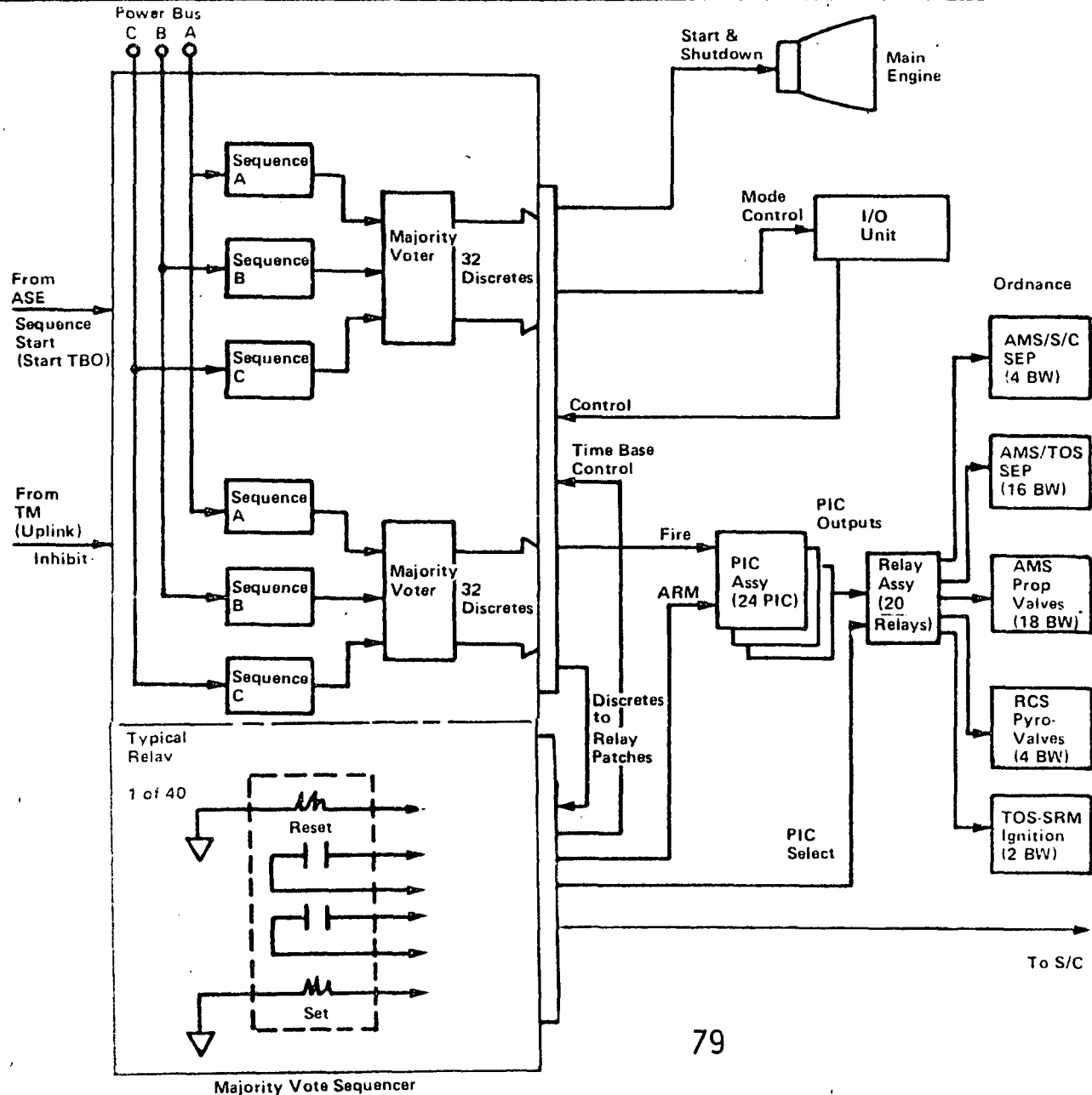

TOS/AMS ELECTRICAL POWER SUBSYSTEM

TOS/AMS electrical power is required for guidance and control, redundant sequencing, and telemetry subsystems for an 8-hour mission. The batteries must have sufficient energy to withstand three contingency deployment attempts. Use of redundant batteries for single fault tolerance improves reliability at low cost. Redundant power control also enhances reliability. A dedicated TDRS power kit, independently powered and controlled is also required.

To satisfy the MVS requirement for triple redundant power sources as well as the requirement for redundantly powering single-bus devices, a three bus two battery system has been designed. Bus A is derived from battery A, Bus B from battery B, and Bus C is a diode-isolated bus operating from both batteries so that a battery failure will disable only one bus. Single-bus devices, such as the input/output unit and telemetry system, are powered from Bus C. Non-flight critical hardware (telemetry) will be fused to prevent failure propagation on Bus C. Each battery is controlled with a separate motor-driven switch. Telemetry power is controlled with a separate motor-driven switch. The electrical power system schematic is shown in the figure.

A 175-Ah silver zinc battery was selected based on a worst-case electrical load analysis. This analysis showed a substantial power margin for each battery. The 175-Ah battery is composed of 19 Silver-Zinc cells in series with a terminal voltage between 26.0 and 32.0 V. The 175-Ah battery will soon be upgraded to 195-Ah and provide even more power margin. The 175-Ah batteries have a 35-day stand life following activation (introduction of electrolyte), a 3-year dry stand life and have been used on Titan III Transtage for more than 10 years. Electrical wiring will satisfy NASA material specifications.

TOS/AMS ELECTRICAL POWER SUBSYSTEM

OSC

MARTIN MARIETTA

- 0 EITHER BATTERY CAN CARRY LOAD WITH 50% MARGIN
- 0 BUS C ASSESSMENT
 - DISTRIBUTE LOADS
 - FUSE NONCRITICAL FUNCTIONS
 - REDUNDANT DIODES
 - GOOD WIRING PRACTICE

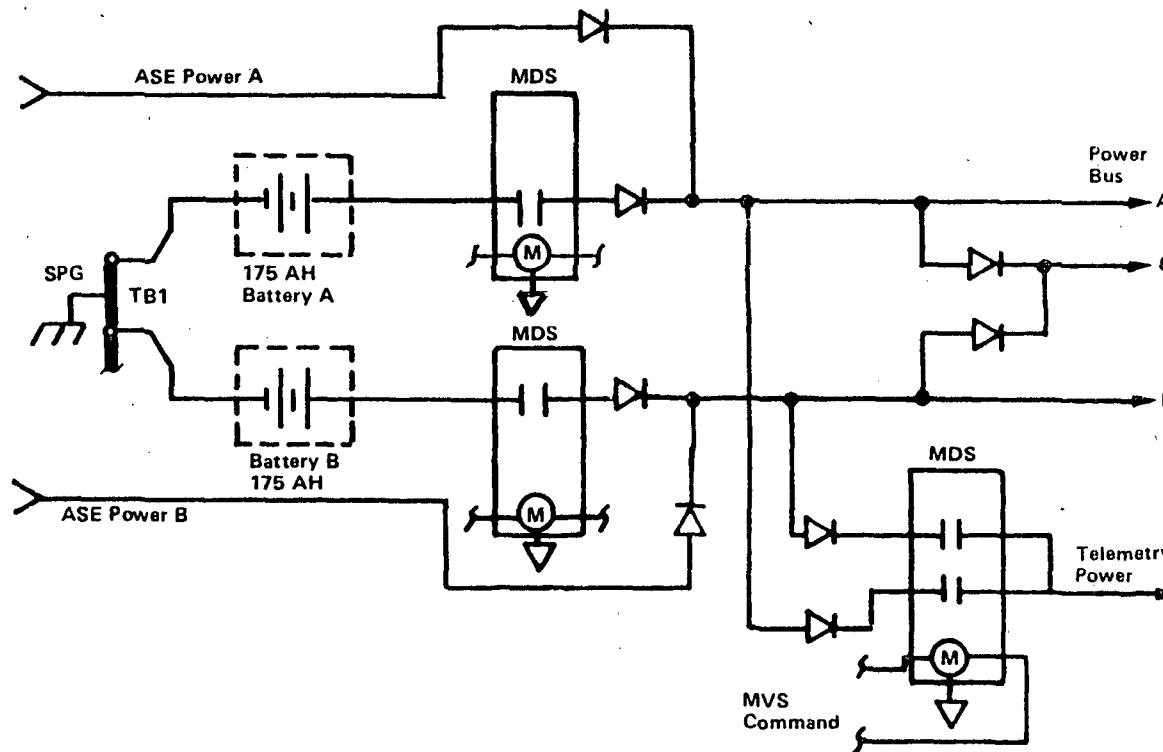

TOS/AMS ELECTRICAL ASE - IUS CRADLE

Three existing IUS ASE batteries will provide electrical power for elevation actuators, umbilical release, and Super-Zip deployment ordnance, as well as to TOS/AMS and spacecraft umbilicals. Battery heaters are supplied directly from orbiter power. Because mechanism power requirements are nearly negligible, excess battery capacity is available for TOS/AMS and TDRS predeployment needs. Power switching is controlled from the AFD power control panel through the power control unit.

The power control panel (PCP) is a two-failure-tolerant control and display panel that provides bus control and monitoring. The panel also controls cradle elevation, power transfer, and deployment separation functions. The power control unit (PCU) accepts signals from the PCP to carry out the commanded functions.

Payload unlatch and elevation requires operation of the PRLAs and tilt actuators. The PRLA is controlled from an existing orbiter panel dedicated to trunnion detainment. The IUS controller and tilt actuator that elevates the payload complies with NASA safety requirements. It incorporates slow rate limiting, motion stop detection, position monitor, and locking control. The TOS/AMS and spacecraft use IUS umbilicals that will be released with the flight-proven IUS hotwire system. The crew will activate the Super-Zip used for deployment from the existing IUS PCP through the PCU.

TOS/AMS testing to assure functionality before deployment will be initiated from the SSP. Changes to existing cabling will be minor because extensive use is being made of existing IUS ASE electrical capability. Routing of the umbilical boom harness will be changed to accommodate the larger diameter AMS stage.

TOS/AMS ELECTRICAL ASE - IUS CRADLE

OSC

MARTIN MARIETTA

0 USE IUS EASE AS-IS

- IUS BATTERIES AND POWER CONTROL PANEL (PCP)
- OPERATE CRADLE MECHANISMS WITH IUS PCP AND POWER CONTROL UNIT (PCU)
- UMBILICAL RELEASE AND SUPERZIP FIRING WITH PCP & PCU
- CONDITION TDRS POWER WITH CONVERTER-REGULATOR

0 CHANGES TO IUS CRADLE FOR TDRS

- UMBILICAL BOOM HARNESS AND ROUTING

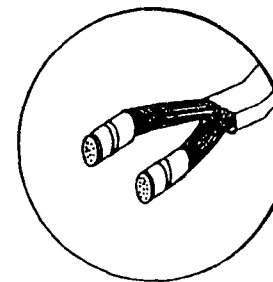
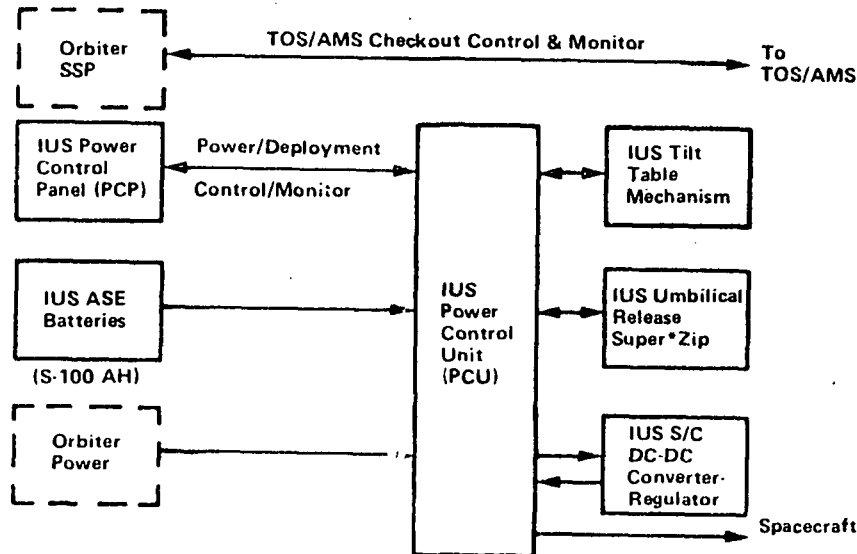
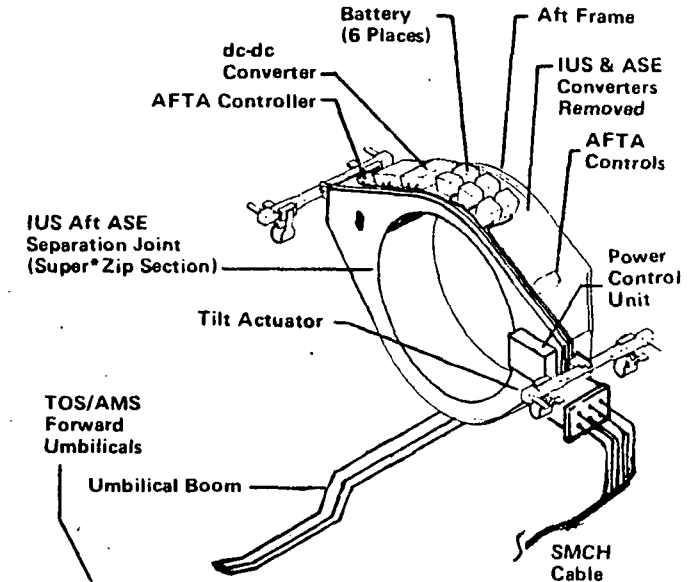

ELECTRICAL GSE FOR TDRS

Electrical GSE is required for ground checkout of the TOS/AMS avionics. Use of the IUS ASE imposes unique requirements as does incorporation of a command and telemetry system. TOS/AMS test and checkout equipment is made up of high quality commercially available components supplemented with Martin Marietta designed and built hardware. It consists of a ground checkout computer; power and control unit; standard switch panel simulator, stray voltage test unit; PCP PRLA simulator, RF test set, and associated checkout cables.

The Ground Checkout Computer (GCC) is a programmable test station that supplies stimuli and monitors TOS/AMS responses. The Hewlett Packard 9836C serves as the system controller and data storage device. The GCC includes the HP 6942A multiprogrammer, 6943A extender frame and required plug-in I/O cards. The multiprogrammer issues the stimuli, acquires and transfers test data to the computer for evaluation. The Hewlett Packard-enhanced BASIC language and operating system software will be used. Test sequences will be developed for TOS/AMS and ASE checkout similar to those developed for TOS.

The Power and Control Unit (PCP), consisted of a power supply, distribution panel, relays, wiring, and connectors, supplies 28-Vdc nominal power to the TOS/AMS and ASE electrical systems during ground test and checkout.

The Standard Switch Panel Simulator (SSP) duplicates SSP functions to electrically control and monitor the TOS/AMS for simulated predeployment checkout and operations.

The Stray Voltage Test Unit breaks-out the pyrotechnic initiator lines for measurement with a NASA-approved stray voltage test instrument.

The Checkout Cable Set (CCS) connects EGSE to the TOS/AMS, ASE and Facility.

The Power Control Panel (PCP)/PRLA Simulator functionally simulates the IUS PCP for control and monitor of the IUS ASE prior to Orbiter installation.

The RF Communications Test Set is a STDN/TDRS RF test unit that generates commands to test the uplink receiver and monitors performance of the downlink telemetry transmitter. The transmitter, generates simulated uplink commands and the receiver accepts and demodulates STDN formatted PM telemetry to assess TOS/AMS transponder performance.

ELECTRICAL GSE FOR TDRS

CSC

MARTIN MARIETTA

- o ELECTRICAL GSE ADDED FOR TDRS
 - PCP SIMULATOR
 - RF TEST SET (STDN/TDRS)

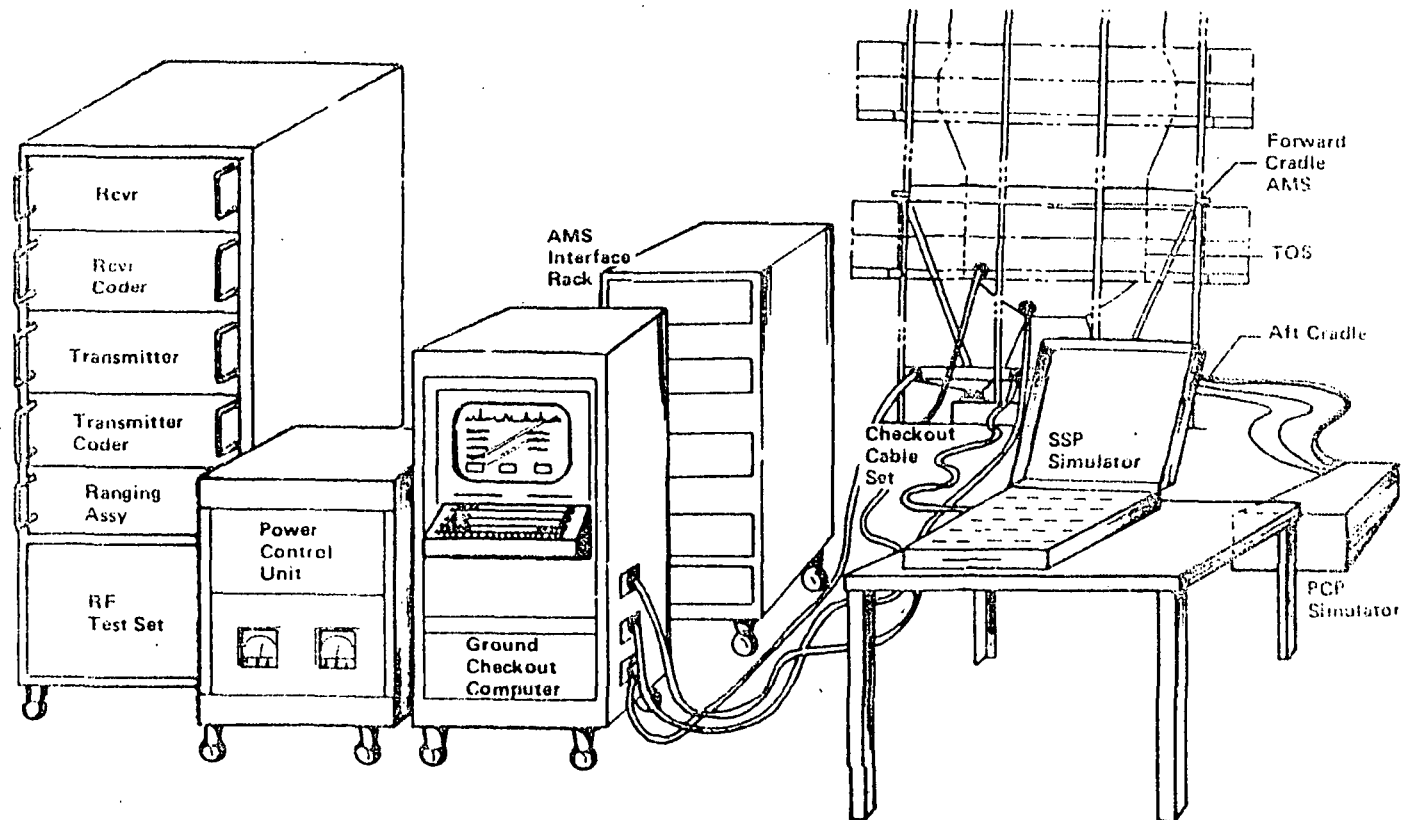

TELEMETRY AND COMMAND KIT FOR TDRS - TASK 3.1.5

The TOS/AMS/TDRS communications kit has been designed for compatibility with the NASA Space Tracking and Data Network (STDN) to permit communications directly with the orbiter after deployment, and to the STDN while in LEO and during geostationary transfer. For compatibility with orbiter systems a telemetry data rate of 16 kbps, which includes 1 kbps of TDRS data, has been baselined. Data from both TDRS and TOS/AMS will be hardlined to the orbiter payload data interleaver (PDI) while attached, and transmitted to the PI after deployment. TOS/AMS data are interleaved with orbiter telemetry for real-time transmission to Mission Control via either the TDRS net or STDN. Maximum range for telemetry to the orbiter assumes the stage is within the beam of the orbiter payload antenna. Ground station coverage for the TOS SRM burn requires use of advanced range instrumentation aircraft (ARIA) unless the orbiter can be positioned to see through the SRM plume. Downlink margins while the TOS/AMS is at GSO are based on preferential orientation.

The TOS/AMS telemetry and command kit is made up of space-proven hardware. The PCM encoder samples TOS/AMS analog, bilevel, and serial digital data, including data from the TDRS, and formats a telemetry output that modulates the downlink transmitter. The S-band transponder is a combination transmitter and receiver that operates on STDN frequencies with STDN formats. Because the 2-W transponder will not close the link at long ranges, its output must be amplified to 20 W by an RF power amplifier. Uplink commands from the orbiter or the ground, in the form of PSK tones, are demodulated in the TOS/AMS receiver. Command decoding is used to inhibit critical majority vote sequencer (MVS) discrettes for TOS/AMS ordnance/propulsion functions. Two omni antennas mounted on opposite sides of the vehicle controlled by an RF switch, provide spherical coverage for uplink and downlink communications.

TELEMETRY AND COMMAND KIT FOR TDRS TASK 3.1.5



COMPONENT	WEIGHT (#)
PCM ENCODER	7
S BAND TRANSPONDER	15
POWER AMPLIFIER	10
RF SYSTEM	7

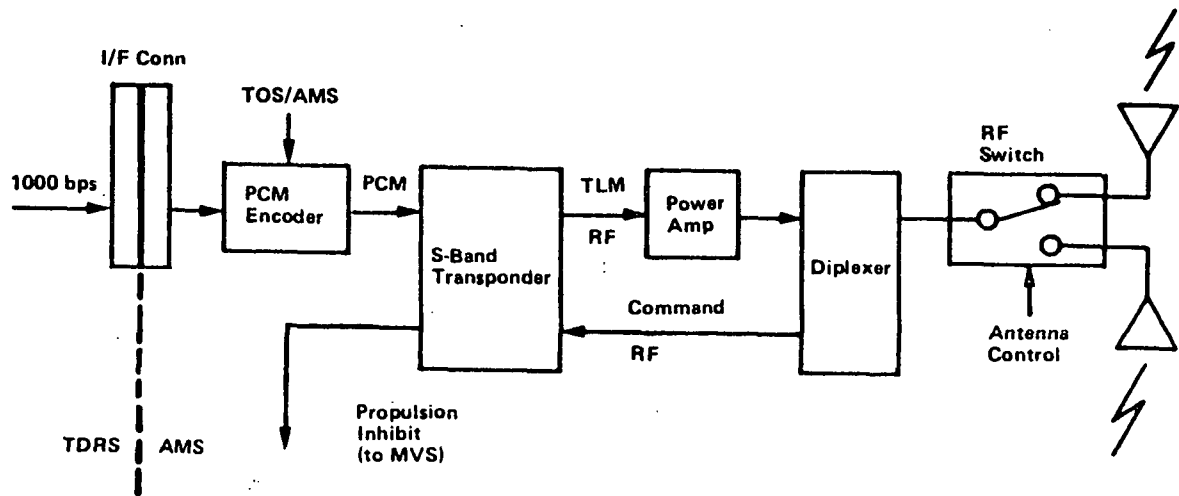

ELECTRICAL POWER KIT FOR TDRS - TASK 3.1.5

A dedicated power kit has been designed to supply the TDRS spacecraft from the ASE before deployment and from the flight vehicle during the TOS/AMS phase. Before deployment, 32 ± 1.0 Vdc power will be supplied from orbiter power via the ASE dc-dc converter with an ASE-dedicated battery as backup. The dedicated battery will assume the load, guaranteeing uninterrupted power in the event of a temporary orbiter power outage. Power will be transferred to the dedicated battery onboard the AMS before deployment from the orbiter. Switching will be overlapped to avoid voltage drops below 24 Vdc.

TDRS power kit equipment installed on the TOS/AMS consists of a dedicated 175-AH battery, power control switch, and power diodes identical to those used on the basic TOS/AMS. Once spacecraft loads are transferred to the TOS/AMS, the AMS/TDRS battery will supply power for up to 8 hours. Power will be removed from the AMS/TDRS interface by the MVS before separation.

ELECTRICAL POWER KIT FOR TDRS-TASK 3.1.5

QSC

MARTIN MARIETTA

FLIGHT VEHICLE COMPONENT	WEIGHT(#)
BATTERY	81
MTR DR SW	3
DIODE	1

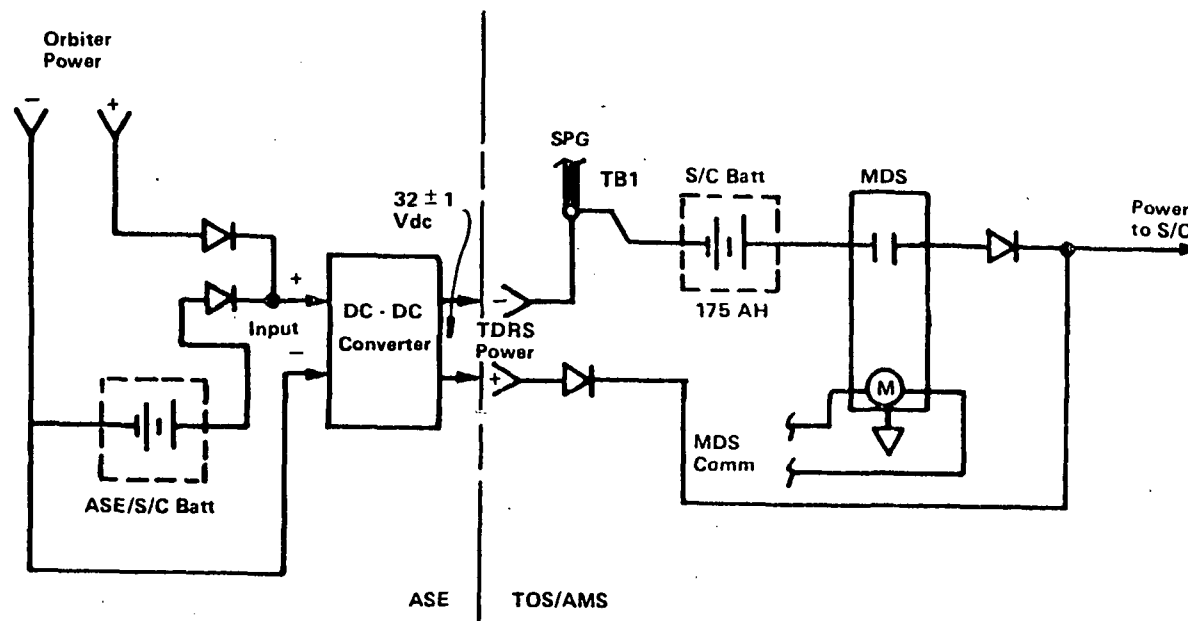

EXISTING IUS CRADLE

OFF THE SHELF HARDWARE



OSC

MARTIN MARIETTA

5.0 . INTERFACE ADAPTER DEFINITION AND STRUCTURAL ANALYSIS

TOS/AMS FOR TDRS IS EFFICIENTLY PACKAGED - TASK 3.1.4

The TOS/AMS structure and thermal control subsystems are flexible in that they are generally not affected by the particular spacecraft that is being flown; they are very compatible with the TDRS vehicle and its requirements. Similarities to the Titan IIIC Transtage structure and thermal control system become apparent when reading this document and reviewing the associated design drawings.

The TOS/AMS is a compact stage that efficiently packages all other subsystem components to meet TDRS strength and performance requirements. The short AMS design (88 in. including adapter to TOS) permitted us to move the forward IUS cradle 11.8 in. aft of its current orbiter position to obtain the overall stage length of 15.9 ft. The forward skirt avionics are shown separated from the vehicle for clarity, and all significant components are identified. There are only three TDRS unique components listed. Components that must be able to radiate to space while in the Orbiter are located on the Orbiter door side of the AMS, and access doors are provided.

TOS/AMS FOR TDRS IS EFFICIENTLY PACKAGED - TASK 3.1.4



MARTIN MARIETTA

TDRS UNIQUE *	
11	DIPLEXER
15	S-BAND TRANSPONDER
17	175 AH BATTERY

Item	
1	Antenna (2)
2	Propulsion Servicing Panel
3	Relay Box
4	Diodes (5)
5	PIC (6)
6	Majority Vote Sequencer
7	Motor Driven Switch, (4)
8	Input/Output Unit
9	Laser Gyro (2)
10	Signal Conditioner (4)
11	Diplexer *
12	10V Power Supply Unit
13	RF Switch
14	PCM Encoder
15	S-Band Transponder *
16	Power Amplifier
17	175 AH Battery *

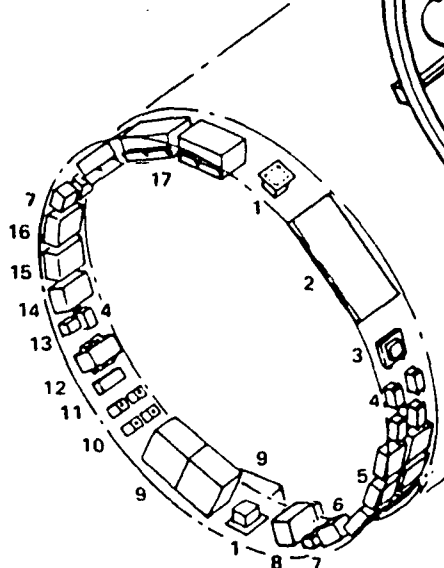
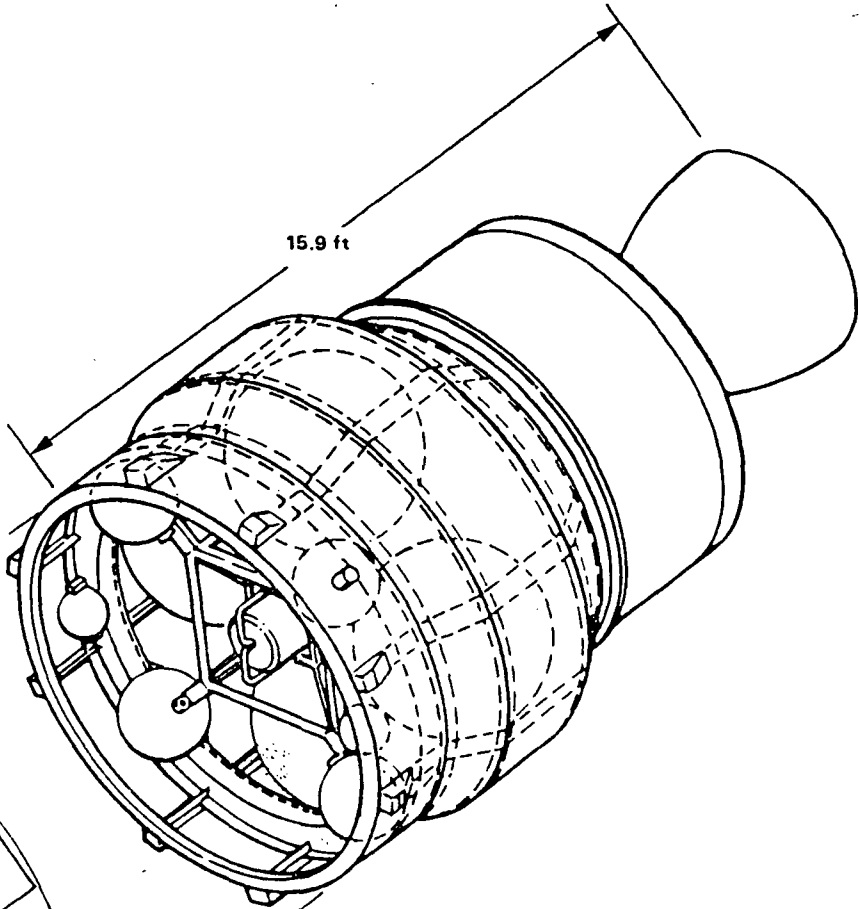

AMS STRUCTURAL FEATURES

- AL SKIN STRINGER DESIGN
- 8 PYROTECHNIC BOLTS/
SPRING SEP FROM TOS
- THERMAL IS PASSIVE
WITH TANK AND LINE
HEATERS
- WEIGHT CONTINGENCY OF
5 % (EXISTING HARDWARE)
20% (NEW OR MODIFIED)

AMS STRUCTURAL ARRANGEMENT

The AMS stage is 88 in. long including the 39-in. long AMS-to-TOS adapter. The 106.8-in. diameter at the forward end of AMS was selected to properly interface with the existing IUS forward cradle design. This diameter was also compatible with providing the eight external fittings to match the existing TDRS interface. The maximum diameter of 117 in. was the minimum that would house the main engine and the four main propellant tanks. All of the smaller pressurant and propellant spheres and the avionics are located in the forward skirt to avoid plume and nozzle radiation heat from the main engine. Two electrical disconnects are located on the forward skirt adjacent to the lowest part of the Orbiter payload bay. The REM assemblies are positioned to achieve maximum moment arms to accomplish pitch, yaw, and roll maneuvers and to minimize local skin plume impingement effects.

The major structural elements of the AMS (without adapter) are four ring frames, eight longerons, eight stringers, three cylindrical/conical skin segments, internal tank and engine support beams, numerous brackets for component support, the eight TDRS spacecraft support fittings, the two trunnion pin fittings, and the fitting that engages the upper keel pin on the IUS forward cradle. The AMS-to-TOS adapter has three frames, eight longerons, 29 stringers, and cylindrical and conical skin segments.

OSC

MARTIN MARIETTA

AMS STRUCTURAL ARRANGEMENT

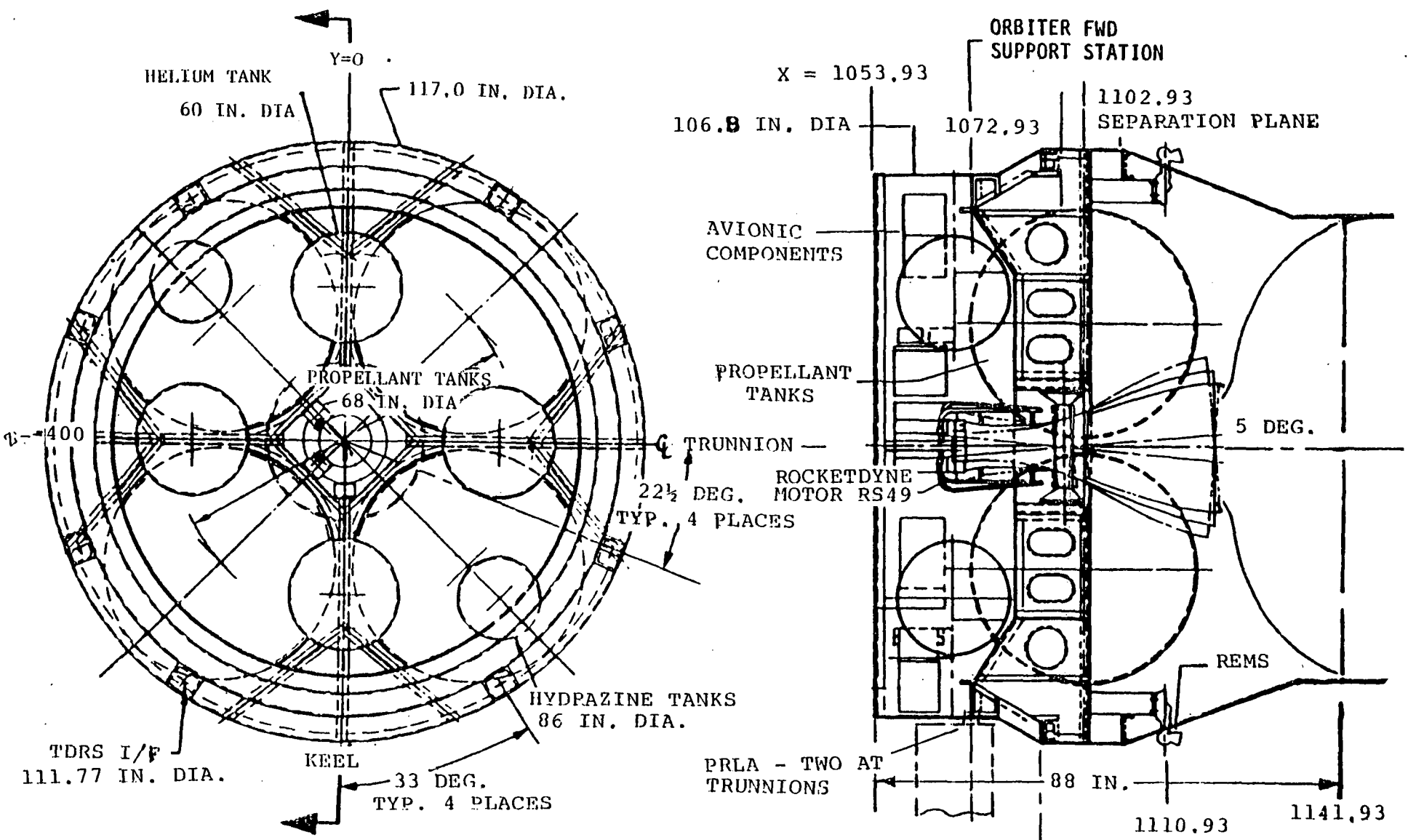

TDRS/AMS PHYSICAL MATING INTERFACE - TASK 3.1.4

The angular location of the eight TDRS interface points corresponds exactly to that which we originally designed into our Titan IIIC Transtage and which became the IUS standard. The preliminary design of the eight TDRS support fittings and the interface frame are shown. Provision is made for the tension bolt and two shear pins at each of the eight locations. The bolt hole interface pattern is a 111.77-in. diameter. Mounting brackets are provided to be compatible with the current location of the eight TDRS interface connectors.

TDRS/AMS PHYSICAL MATING INTERFACE - TASK 3.1.4

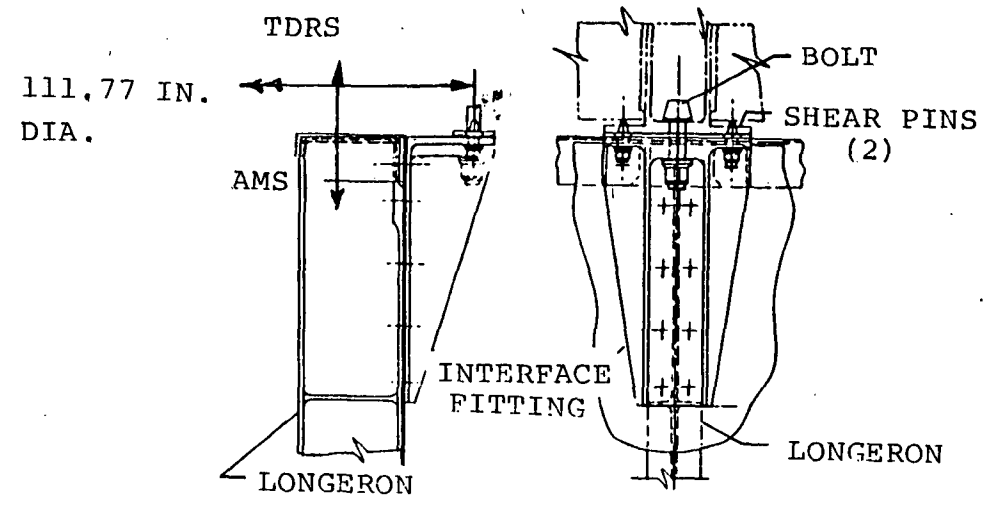
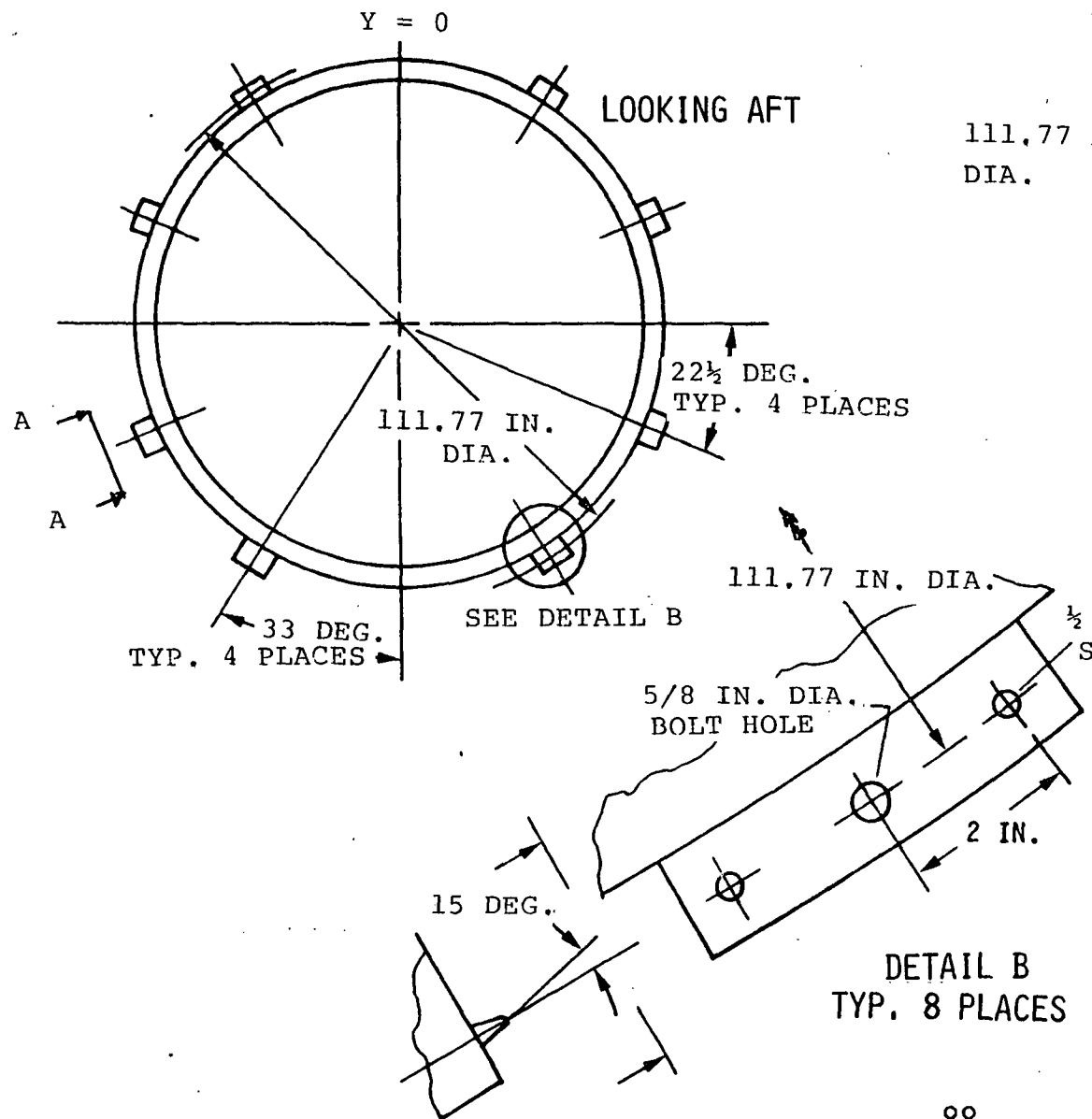

VIEW A-A, ROTATED

NOTE: THE CURRENT LOCATION OF THE EIGHT TDRS I/F CONNECTORS IS UNCHANGED

AMS STRUCTURE DETAILS - TDRS CONFIGURATION

Station 1072.93 is the AMS and Orbiter Station at which the forward IUS cradle is located. For TDRS application, the AMS frame at this station has two trunnion pin fittings and one keel fitting to be compatible with the current IUS cradle structure. The pins and fittings are fabricated of 6Al-4V titanium alloy. As shown, the fittings are designed to provide carry through structure for the frame internal shears, axial loads and bending moments.

A detail weight break down for the structural elements is listed. Structural sizes were determined for an 8000 pound cantilevered spacecraft with a c.g. 80 inches forward of the AMS forward interface. Strength margins of safety for the TDRS spacecraft loads are therefore more than adequate. The use of 7075-T73 for the basic structure will ensure that no stress corrosion concerns exist.

AMS STRUCTURE DETAILS - TDRS CONFIGURATION

• TRUNNION PIN AND FITTING
STATION 1072.93

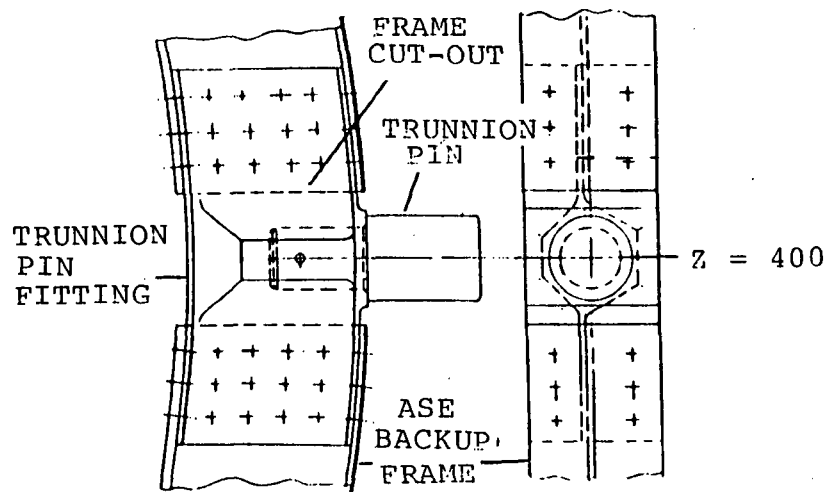

• KEEL FITTING
STATION 1072.93

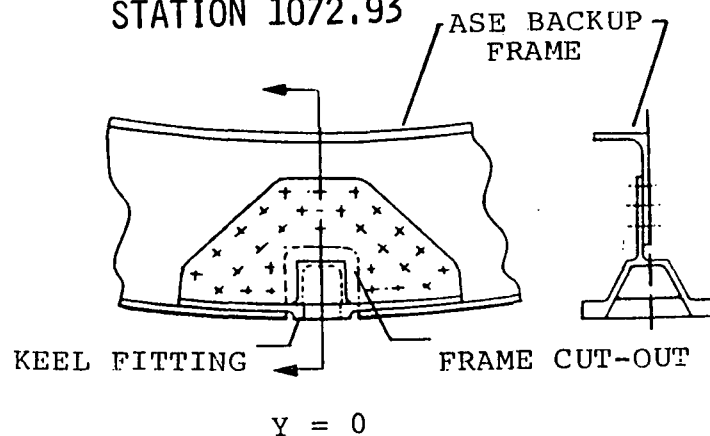

COMPONENT NOMENCLATURE	WEIGHT	MATERIAL
SPACECRAFT I/F SUPPORT RING	20.0	ALUMINUM
S/C I/F BOLT RING BRACKETS	19.2	ALLOY
FWD RING AT ATTACH POINT	100.0	7075-T73
INTERMEDIATE RING FRAME-FWD	30.0	
INTERMEDIATE RING FRAME-AFT	20.0	
SEPARATION RING FRAME	15.0	
SEPARATION FITTINGS	12.0	
FWD CYLINDRICAL SKIN	35.4	
AFT CYLINDRICAL SKIN	24.1	
CONICAL SECTION SKIN	28.0	
STRINGERS	30.2	
LONGERONS	37.2	
TANK SUPPORT BEAMS	47.5	
TANK SUPPORT RINGS	51.7	
ENGINE MOUNTING STRUCTURE	3.0	
ASE ATTACH FITTINGS (TRUNNION & KEEL)	60.0	TITANIUM TI-6AL-4V
TOS ADAPTER		ALUMINUM
- FWD RING	43.5	ALLOY
- INTERMEDIATE RING	30.4	7075-T73
- AFT RING	33.9	
- STRINGERS	26.5	
- SKIN CONICAL	83.0	
- SKIN CYLINDRICAL	13.7	
- LONGERONS	56.0	
- SEPARATION FITTINGS	12.0	

DYNAMIC LOADS ANALYSIS

SUMMARY OF CONTACTS WITH VARIOUS ORGANIZATIONS

Prior to modeling the TOS/AMS/TDRS cargo element for a dynamic loads analysis, an effort was made to contact a number of organizations with past experience in evaluating the performance of the IUS soft suspension system.

The consensus of the nine organizations listed clearly indicated the need for load alleviation to protect the TDRS spacecraft. The IUS soft suspension has flight proven capability to provide such alleviation. Subsequently, it was selected with slight modification as part of the baseline configuration for support of the TOS/AMS/TDRS in the payload bay.

DYNAMIC LOADS ANALYSIS
SUMMARY OF CONTACTS WITH VARIOUS ORGANIZATIONS

OSC

MARTIN MARIETTA

BACKGROUND FOR SOFT SUSPENSION SYSTEM

- o OSC - 19 DECEMBER 1983 - FRANK VAN RENSSELAER
- o BAC TELECON - 09 JANUARY 1984 - WES MARTIN - IUS DYNAMICS
- o OSC/JSC ORIENTATION REVIEW - 11 JANUARY 1984
- o CENTAUR CDR - 16 JANUARY 1984 - DYNAMIC ANALYSIS
- o MSFC MEETING - 19 JANUARY 1984 - DISCUSSION OF IUS
- o AEROSPACE CORP. MEETING - 27 JANUARY 1984 - ERNIE SCHEYHING - IUS
- o GODDARD TELECON - 31 JANUARY 1984 - DAN KNIGHTON - TDRSS DYN/STRESS
- o JSC TELECON - 31 JANUARY 1984 - DAVE HAMILTON - STS DYN/LOADS
- o JSC TELECON - 3 FEBRUARY 1984 - KEN COS - ORBITER STABILITY

0062G-14-PW

STRUCTURAL DYNAMICS APPROACH

NASA GSFC has recommended TDRS - critical forcing functions for two Lift Off conditions and one Abort Landing condition with frequency cut-off at 35 Hz for use in transient dynamic loads analyses. This allows a direct comparison of MMC-generated TDRS loads to be made with similar dynamic loads previously generated by Rockwell and Boeing on the IUS/TDRS.

Twenty critical points in the TDRS structure have been monitored for max/min acceleration loads. In addition, time consistent base drive acceleration histories have been supplied to GSFC for a precise evaluation of structural margin at these points.

GSFC's analyses show all margins are positive.

STRUCTURAL DYNAMICS APPROACH

QSC

MARTIN MARIETTA

DYNAMIC LOADS ANALYSIS - LIMITED INITIAL LOADS CYCLE

- o P/L IN LO CONFIGURATION
 - TWO TDRS-CRITICAL LO FORCING FUNCTIONS
 - PER CONCURRENCE FROM GSFC AND JSC

- o P/L IN ABORT LANDING CONFIGURATION
 - ONE LANDING FORCING FUNCTION
 - PER CONCURRENCE FROM GSFC AND JSC

- o MONITOR RESPONSE OF 20 CRITICAL POINTS IN TDRS PER GSFC (DAN KNIGHTON)

TOS/AMS CONFIGURATION FOR TDRS INDICATING INTERFACE
ELEMENTS

Finite element models of all structure in the cargo element were assembled from the following sources:

TDRS (-11) Spacecraft Loads Verification Model originally developed by TRW and supplied to MMC by NASA GSFC.

IUS cradles originally developed by Boeing and supplied to MMC by NASA JSC. The cradles have a spacing 11.8 inches closer together in the TOS/AMS configuration compared to the original Boeing design. Torsion bar suspension with a 4-bar linkage is used in the front cradle with leaf springs in the aft cradle. Both friction dampers and "v²" dampers are modelled. Non-linear characteristics of the dampers are preserved in the transient loads analysis.

Mass and stiffness properties of the TOS stage with Lockheed "super-zip" were adapted from Boeing data. The AMS stage was modelled from basic properties of MMC's structural design including interface stiffness at TDRS attaching points.

The entire cargo element was coupled to existing in-house models of the Orbiter in both Lift-off and Landing configurations.

TOS/AMS CONFIGURATION FOR TDRS INDICATING INTERFACE
ELEMENTS

OSC

MARTIN MARIETTA

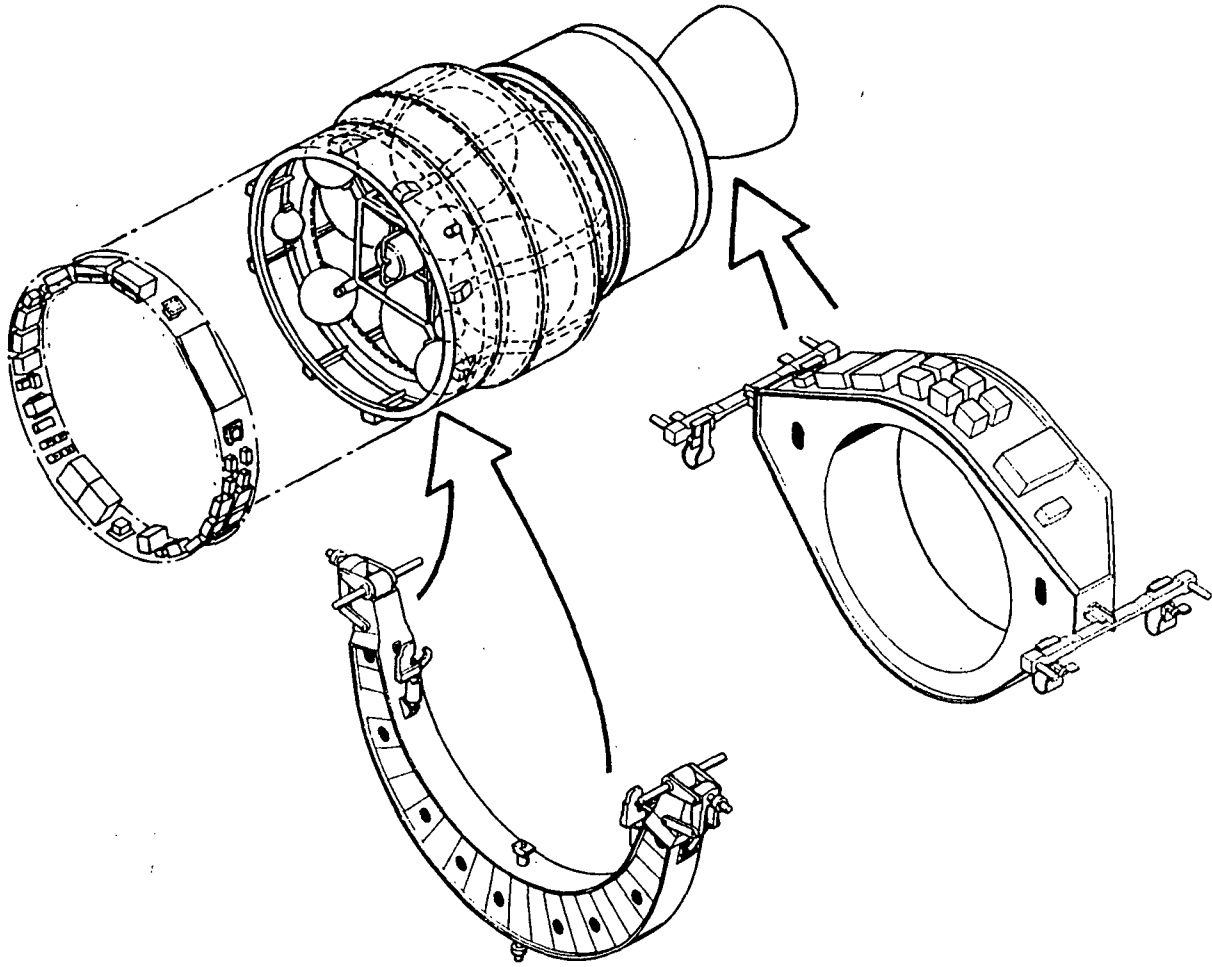

LOAD FACTORS AT CARGO ELEMENT CG ARE LESS THAN LOAD FACTORS
REQUIRED BY NASA ICD 2-19001 - TASK 3.1.3

This table provides an overall comparison of expected response with ICD 2-19001 Guidelines recommended for initial sizing of structure.

The overall response to Lift-off and Landing conditions is seen to be less than the ICD recommended max/min values for all six degrees-of-freedom of the cargo element c.g.

It follows from this conservative approach, that dynamic stresses within the structural elements of TDRS will have positive margins if the TDRS design is consistent with ICD requirements. This has been demonstrated by GSFC's analysis of I/F loads and accelerations generated by MMC.

LOAD FACTORS AT CARGO ELEMENT CG ARE LESS THAN LOAD FACTORS
 REQUIRED BY NASA ICD 2-19001 - TASK 3.1.3

CSC

MARTIN MARIETTA

	Liftoff						Abort Landing			
	LO942		LO942		ICD 2-19001		L4101		ICD 2-19001	
	Max	Min	Max	Min	Max	Min	Max	Min	Max	Min
Translation (g's)										
X	-0.19	-2.86	0.19	-3.09	-0.2	-3.2	+0.24	-0.56	+1.8	-2.0
Y	+0.12	-0.08	0.13	-0.10	+1.4	-1.4	+0.01	-0.01	+1.5	-1.5
Z	+0.65	-0.68	0.57	-0.80	+2.5	-2.5	+2.06	+0.46	+4.2	-1.0
Rotation Rad/s²										
θ_x	+1.31	-1.63	+1.66	-1.35	+3.7	-3.7	+0.24	-0.31	+4.8	-4.8
θ_y	+1.70	-1.83	+2.51	-1.74	+7.7	-7.7	+0.58	-1.12	+5.4	-5.4
θ_z	+1.53	-1.50	+1.35	-1.14	+3.1	-3.1	+0.17	-0.13	+3.0	-3.0

SOFT SUSPENSION ALLEVIATES TDRS LOADS

Peak accelerations at 20 critical points of the TDRS are compared with IUS/TDRS accelerations previously obtained from identical forcing functions used by Rockwell and Boeing. The latter responses have been enveloped by strength allowables to form the envelope shown in the last right-hand column. Numbers denoted by an asterisk indicate an exceedance in response obtained by MMC.

This is only an indication of possible excessive loads, however, to determine actual stresses, it is necessary to base-drive the TDRS structure at its attach points to the AMS with time-consistent accelerations and monitor peak stresses at the 20 points.

MMC has provided NASA GSFC with magnetic tapes of the base-drive accelerations. Subsequent analysis by GSFC has shown positive margins at all points.

Maximum deflections calculated by MMC are approximately 4.5 inches. This is well within the allowable clearance envelope.

SOFT- SUSPENSION ALLEVIATES TDRS LOADS



MARTIN MARIETTA

No.	Identification	SSV Coord	TOS/AMS/TDRS Peak Accelerations, g			IUS/TDRS Envelope** Peak Accelerations, g
			LO942	LO939	L4101	
1	SGL Antenna Top	X	3.03	3.24	0.52	3.3
2		Y	3.34 *	3.78 *	0.86	2.9
3		Z	4.28	5.14	2.76	14.0
4	SGL Feed	X	5.22 *	5.61 *	1.24	5.2
5		Y	3.09 *	3.12 *	0.54	2.6
6		Z	6.07	7.57	3.22	14.0
7	C-Band Feed	X	3.93 *	4.41 *	0.63	3.9
8		Y	1.69	1.77 *	0.19	1.7
9		Z	4.66	4.93	3.38	5.8
10	Omni	X	4.59	4.86	0.77	5.2
11		Y	6.19	6.96	1.00	10.6
12		Z	14.06	16.37	9.67	42.6
13	Upper Propellant Tank	X	3.06	3.23	0.54	3.3
14		Y	0.79 *	0.68 *	0.08	0.6
15		Z	1.10	1.45	2.17	3.6
16	+Y SP Boom	Z	1.26	1.49	2.35	3.6
17	+Y SP Outer Hinge	Y	6.40	5.65	0.74	11.4
18	+X SA Antenna Ribs	Z	14.27	9.59	5.82	20.3
19		Y	12.90	15.82	1.67	20.0
20	C-Band Antenna cg	Y	3.08 *	3.62 *	0.39	2.7

**Source: NASA GSFC

* TIME CONSISTANT EVALUATION BY GSFC INDICATES NO PROBLEM

REACTION LOADS AT ORBITER/CARGO ELEMENT INTERFACES ARE WITHIN ORBITER STRENGTH ENVELOPE

Allowable loads at Orbiter interface attach points with the Cargo element are defined by ICD 2-19001. The table shows actual loads at these points generated by the analyses of the TOS/AMS/TDRS response to three forcing functions. All loads are well within Orbiter allowables shown in the right-hand column. Also shown for comparison are the responses calculated by Rockwell on the IUS/TDRS. Several large differences in magnitude are attributed to Rockwell's envelope embracing 22 Lift-Off and 6 Landing forcing functions compared to MMC's use of 3 "worst case" forcing functions.

REACTION LOADS AT ORBITER/CARGO ELEMENT INTERFACES ARE
WITHIN ORBITER STRENGTH ENVELOPE

CSC

MARTIN MARIETTA

		L0942		L0939		L4101		RI Envelope IUS/TDRS	ICD 2-19001 ALLOWABLES
		Max	Min	Max	Min	Max	Min		
Aft ASE									
Spreader Beams	ST Aft Z	1,616	- 6,132	716	- 6,033	10,160	2,129	10,474	143,050
	ST Fwd X	- 3,533	- 63,510	5,342	- 66,760	5,603	- 11,040	66,638	
	ST Fwd Z	1,606	- 6,172	733	- 6,039	10,190	2,183	10,541	74,750
	PT Fwd X	- 5,081	- 60,350	3,283	- 65,150	5,785	- 10,290	64,199	
	PT Fwd Z	1,361	- 5,120	1,037	- 5,960	10,110	2,105	10,377	74,750
	PT Aft Z	1,356	- 5,084	1,055	- 5,923	10,080	2,054	10,315	143,050
Centering Springs	ST Fwd Y	1,654	72	1,732	- 229	- 73	- 598	4,266	
	ST Aft Y	344	- 835	411	- 801	- 115	- 521	3,297	
	PT Fwd Y	26	- 1,406	88	- 1,491	560	70	3,879	
	PT Aft Y	841	- 519	894	- 559	479	77	3,570	
Fwd ASE									
Four-Bar Linkage	ST X	1,195	- 2,585	282	- 1,666	762	- 998	2,099	
	ST Z	12,070	- 6,541	10,470	- 7,419	24,500	5,721	25,128	62,200
	PT X	1,059	- 2,334	460	- 1,996	749	- 973	2,080	
	PT Z	12,020	- 4,841	11,600	- 6,097	24,580	5,714	25,230	62,200
Keel	X	957	- 2,421	686	- 1,858	1,073	- 1,054	2,044	8,000
	Y	3,971	- 2,803	3,924	- 3,512	355	- 247	8,820	70,400

Legend:

ST Starboard
PT Port

STRUCTURAL DYNAMIC RESULTS

No short-cuts have been taken in MMC's analyses. The finite element models used are accurate dynamic models of the original NASTRAN or other finite elements containing many more degrees-of-freedom. Modal coupling of all sub-structures includes corrections for residual flexibility at interface points due to frequency cut-off imposed in the analysis.

Nonlinear forces from shock-strut and Coulomb damping in the IUS cradles have been preserved in the response analyses. In summary, the loads analysis is consistent with state-of-the-art technology.

QSC

MARTIN MARIETTA

STRUCTURAL DYNAMICS RESULTS

- o RESULTS ARE BASED ON A DETAILED ANALYSIS REQUIRED BY NASA JSC TO PROVE LAUNCH FEASIBILITY. RIGOROUS ANALYSIS INCLUDES ALL NON-LINEARITIES IN IUS CRADLES

- o WE HAVE PROVIDED TDRS INTERFACE BASE DRIVE ACCELERATIONS (TIME CONSISTENT) TO GSFC FOR DETAILED STRESS EVALUATION. GSFC FEEDBACK INDICATES THAT ANALYSIS RESULTS ARE ACCEPTABLE.

- o ALL RESULTS TO DATE SHOW TOS/AMS PLUS SOFT SUSPENSION WILL PROVIDE A SATISFACTORY LAUNCH/ABORT LANDING ENVIRONMENT FOR TDRS.

USE OF IUS CRADLES SATISFIES TDRS LOADS AND DYNAMICS

ASE CONCLUSIONS/RECOMMENDATIONS

Loads analyses completed to date indicate satisfactory load alleviation for the fragile TDRS antennae when supported on the TOS/AMS structure by modified IUS cradles during Launch or Abort Landing.

A study of TDRS loads using TOS-derived direct mounted cradles has been completed (17 May 1984). Results indicate unacceptable accelerations at + X Single Axis Antenna Ribs in the SSV Z-direction during Abort Landing. Lift-Off is less severe but exceeds allowable accelerations. A time-consistent base-drive analysis is in progress (31 May 84) by NASA GSFC.

ASE CONCLUSIONS/RECOMMENDATIONS

QSC

MARTIN MARIETTA

- o BASELINE SSS (SOFT SUSPENSION SYSTEM) FOR TDRS PLUS OTHER TRANSITIONING SPACECRAFT
- o USE IUS' ASE AS THE SSS
- o MAINTAIN DIRECT MOUNT AS ALTERNATE
 - EVALUATE DIRECT MOUNT FOR TDRS BY 17 MAY 1984
 - PROPOSE AS BASELINE FOR FUTURE SPACECRAFT

00246-25-PW

DIRECT MOUNTED CARGO ELEMENT

The direct mount cradle system which was given some consideration for TOS/AMS/TDRS is shown. The four longitudinal members provide a structurally efficient load path for transferring TOS/AMS longitudinal (X) loads from the TOS aft skirt to the Orbiter longeron trunnion support points at the aft cradle. The TOS aft skirt is attached to a 9.2-in.-long Super-Zip segment that is bolted to the aft interface of the TOS SRM. The cradle interfaces with the Orbiter through two longeron trunnion pins. Passive Orbiter latches are used that incorporate functional, strength, and finish requirements to allow the TOS/AMS to be rotated about these pins during the deployment sequence.

The forward cradle has no mechanical tie to the AMS structure. It clamps around the AMS through a series of bearing pads spaced at 20 deg. This arrangement provides a stiff, efficient load path that allows for weight reductions in both the AMS frame and the ASE. This cradle provides the keel-pin tie to transfer lateral (Y) loads to the Orbiter in addition to two trunnion pins to transfer Z loads. The cradle is primarily a stiffness design other than locally at the three pin locations. For this reason, we are using graphite/epoxy cap members to achieve a higher stiffness-to-density ratio. The longitudinal links are buckling-critical as columns, and, therefore the use of graphite/epoxy for the four members gave us additional weight saving.

The TOS/AMS deployment sequence consists of unlatching and opening the upper half of the forward cradle, rotating the TOS/AMS about the aft trunnion pins to a 45-deg position, separating the TOS/AMS from the TOS aft skirt with Super-Zip and mechanical springs, and then rotating the aft cradle back into the original position. The forward cradle's upper half is also closed and relatched.

DIRECT MOUNTED CARGO ELEMENT

QSC

MARTIN MARIETTA

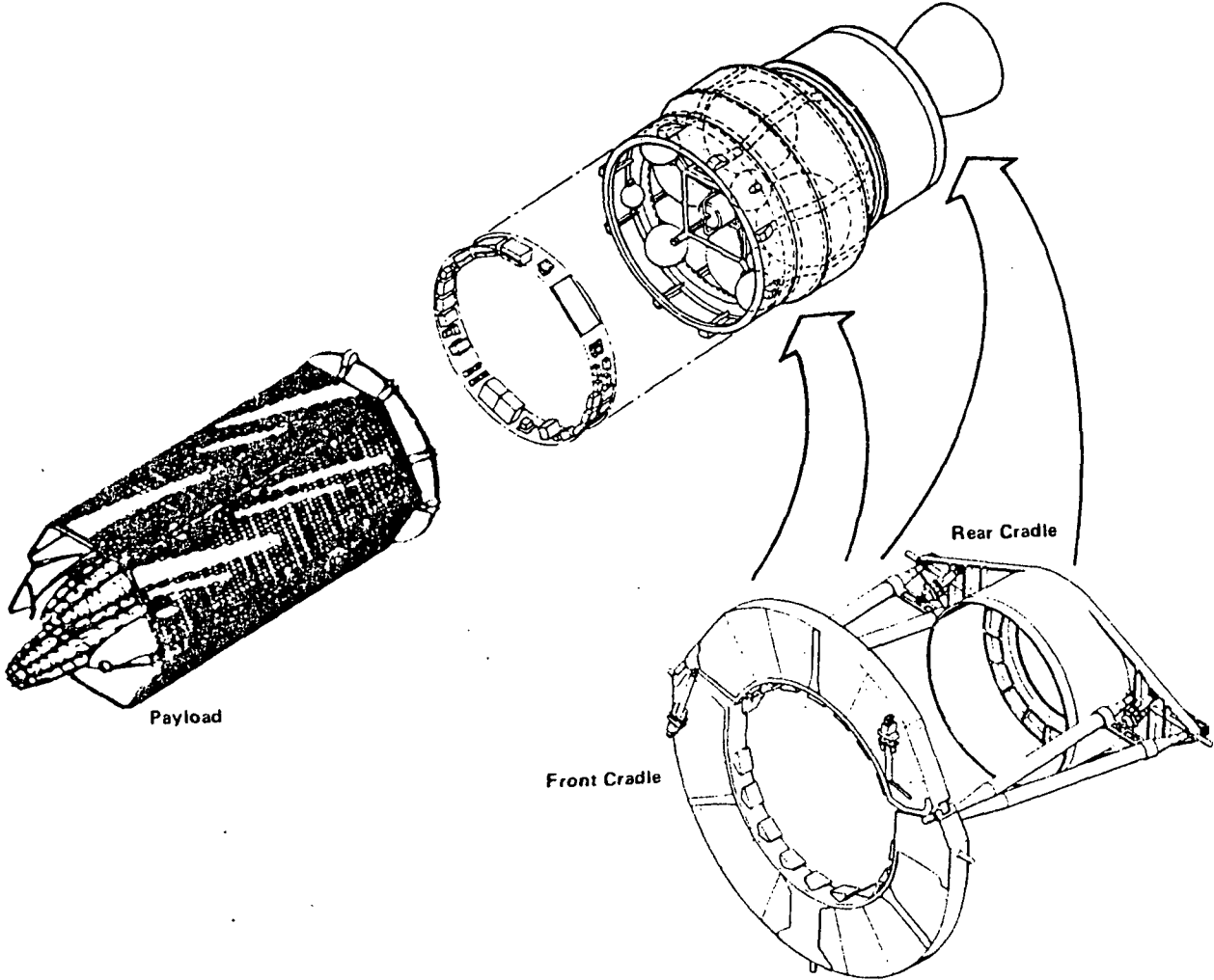

MODIFICATION TO IUS CRADLES

The existing Inertial Upper Stage (IUS) cradle design with load alleviation structure and mechanisms was selected to support the TDRS TOS/AMS since it has demonstrated the soft ride that TDRS requires. The required modifications to match our vehicle design are small and are described in the following paragraphs. The ASE design includes all mechanisms and avionics necessary to deploy the TDRS TOS/AMS from the Orbiter bay.

In designing to achieve a minimum length AMS stage, we found it advantageous to interchange the right and left hand PRLAs on the IUS forward cradle. Since the trunnion pins are not on the cradle center plane this reversal gave a distinct benefit in designing the AMS shell structure so as to clear the IUS cradle and also the main propellant tanks. This can be seen in the vehicle profile shown on page 87.

Another modification to the existing IUS cradle configuration is in the umbilical cable tray design. This simple change is required for two reasons. First, the AMS is larger in diameter than IUS and the current cable tray would physically interfere with the AMS. Secondly, we have moved the forward IUS cradle 11.8 in. closer to the aft cradle, thus requiring a change in the design of the support which is provided by the forward cradle.

MODIFICATION TO IUS CRADLES



MARTIN MARIETTA

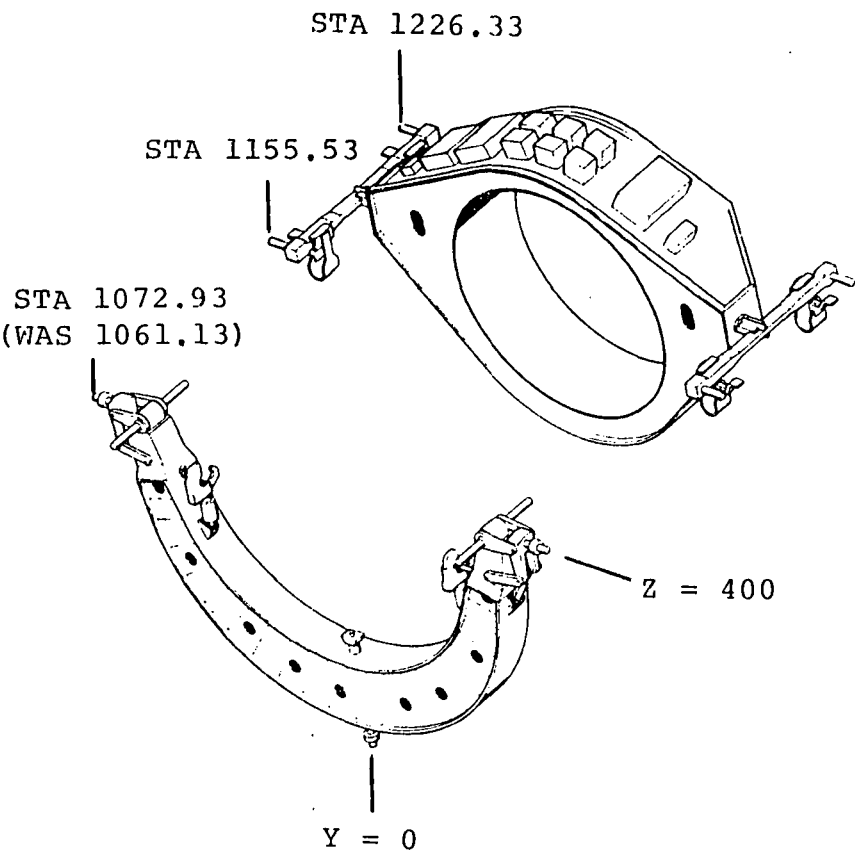

ITEM TO BE MODIFIED	DISPOSITION
PRLA AND PRLA TRACK	REMOVE PRLA AND PRLA TRACK FROM RIGHT-HAND SIDE AND REINSTALL ON LEFT-HAND SIDE BY ROTATING THEM 180° IN THE HORIZONTAL PLANE. REPEAT FOR INSTALLATION OF LEFT-HAND PRLA AND TRACK ON RIGHT-HAND SIDE.
PURGE LINE	REMOVE COMPLETELY. NO REPLACEMENT
UMBILICAL	REMOVE EXISTING UMBILICAL AND INSTALL NEW DESIGN UMBILICAL. (11.8" SHORTER)

AMS THERMAL CONTROL DESIGN BASELINE - TASK 3.1.5

The TCS baseline concept uses proven techniques to achieve a versatile and lightweight design. The exterior surfaces are coated with white paint, which results in moderate skin temperatures for a wide range of Orbiter and free-flight environments. The interior surfaces are painted black for uniform heat distribution. The multilayer insulation (MLI) used on the AMS is fabricated from perforated 1/2-mil double aluminized mylar, with face sheets of perforated 2-mil double aluminized kapton. The layers are separated by dacron netting. The aft halves of the propellant tanks are insulated with three layers of gold-plated 1/2-mil stainless steel foil, similar to that used on the Transtage program. The aft structure and interior of the AMS are protected from nozzle radiant heading by a gold-plated 1-mil stainless steel radiation shield that is attached to the structure with low thermal conductivity fasteners. Low thermal conductivity wafers, washers, and standoffs are used to minimize heat loss from the propulsion and avionics components to the AMS structure. The aft skirt is protected from RCS plume heating by local patches of MLI covered with dense-weave quartz cloth. The propellant tank valves and lines adjacent to the nozzle are protected from plume heating by 1/2-in. min-k insulation blankets covered with dense-weave quartz cloth.

Heaters are used on propulsion system and avionics components to maintain acceptable temperatures in cold Orbiter and free-flight attitudes. The forward face of the AMS has an MLI blanket with no fewer than 15 layers that will meet the effective emissivity requirements. MLI is installed on the solid rocket motor to minimize temperature gradients between the center of the propellant grain and motor case before ignition and for plume/nozzle heating protection after ignition. MLI is added to the solid rocket motor's forward dome to reduce the heat soak back influence on subsystems.

AMS THERMAL CONTROL DESIGN BASELINE - TASK 3.1.5

PASSIVE

- o MLI BLANKETS
 - BI-PROPELLANT AND RCS TANKS & LINES
 - INTERIOR OF AMS
 - FRONT FACE OF AMS
- o WAVELENGTH SELECTIVE COATINGS
 - WHITE PAINT ON EXTERIOR SURFACES
 - LOW EMITTANCE COATINGS ON INTERIOR SURFACES
- o CONDUCTION PATH CONTROL
 - CONDUCTIVE STAND-OFFS FOR AVIONICS AS REQUIRED
- o HIGH TEMPERATURE PROTECTION
 - GOLD PLATED STAINLESS STEEL FOIL ON BI-PROPELLANT TANKS
 - MIN-K AND QUARTZ CLOTH

ACTIVE - HEATERS

- o OXIDIZER TANKS, LINES AND VALVES
- o FUEL VALVES
- o RCS TANKS, LINES, VALVES AND CATALYST BEDS
- o SELECTED AVIONICS

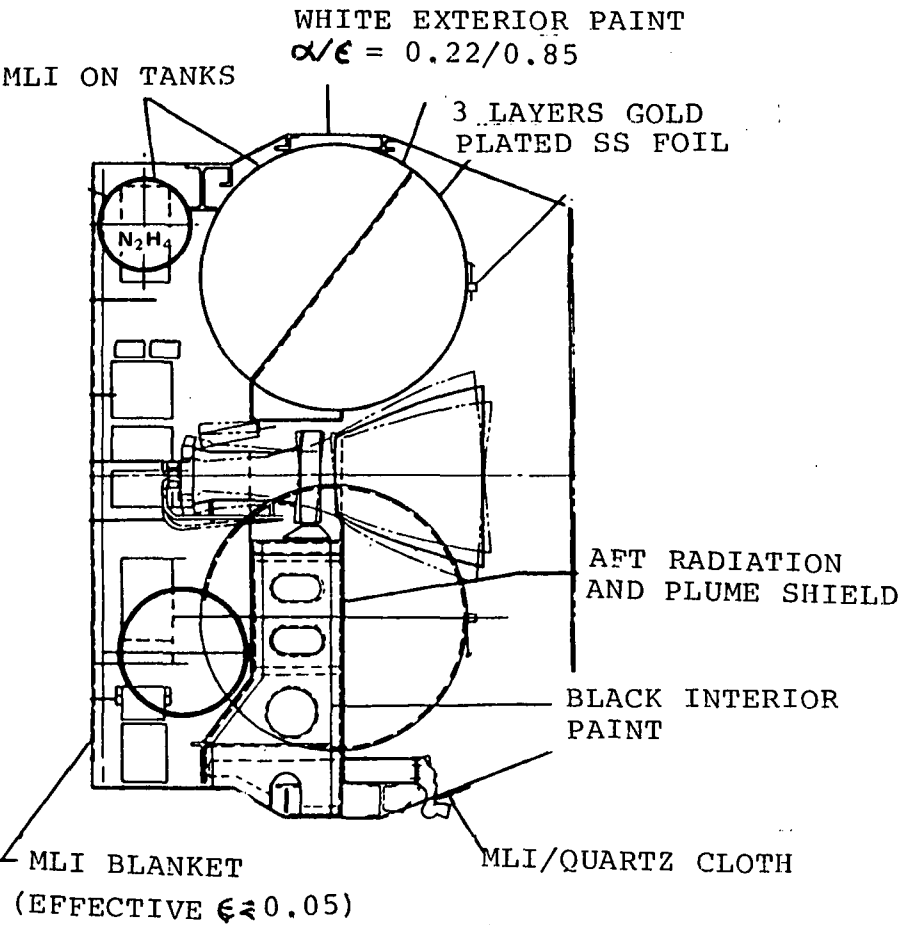

0112G-20-JM

THERMAL ANALYSIS RESULTS

The TOS/AMS thermal control system (TCS) concept is based on consideration of component requirements, TDRS and Orbiter interface requirements, and expected environments. The Shuttle Orbiter/Cargo Standard Interfaces, ICD2-19001; the Standard Integration Plan for Deployable/Retrievable-Type Payloads, JSC-14070; and the Safety Policy and Requirements for Payloads using the Space Transportation System, NHB 1700.7A, were consulted to derive the STS mission phase design requirements. Free-flight design criteria were derived from guidelines given in MIL-STD-1540, considering available avionics and propulsion system temperature requirements and TDRS thermal requirements. While the TDRS mission is for 7 hours, the basic thermal control requirement of 7 days on orbit is satisfied.

The hot case analysis shows that the TOS concept provides adequate protection in hot environments. The highest avionics temperatures are reached after start of the main engine burn. Radiation of heat from the motor chamber to the equipment bay is moderated by an MLI blanket that encloses the chamber, but significant heating still occurs. Main engine heating of the propellant tank aft insulation results in high average temperatures of 1350°F, with temperatures adjacent to the nozzle expected to be much higher. This demonstrates the need for high-temperature insulation.

The cold case analysis shows that the free-flight environment can be controlled for the avionics. The propulsion system temperatures were acceptable throughout the mission due to the thermal mass and insulation. Results also show that heaters are necessary for the avionics if the orbiter bay environments are to survive for long periods of time. Other heaters can be added as necessary.

QSC

MARTIN MARIETTA

THERMAL ANALYSIS RESULTS

- o TDRS ATTITUDE REQUIREMENTS ARE SATISFIED BY THE AMS ATTITUDE CONTROL SYSTEM DESIGN
 - RCS THRUSTER CONFIGURATION IS THE SAME AS IUS
- o THE MLI BLANKET ACROSS THE FORWARD AMS INTERFACE COMPLIES WITH THE TDRS REQUIREMENT
- o TDRS I/F ATTACH POINT TEMPERATURE LIMITS CAN BE SATISFIED WITH OUR BASELINE THERMAL CONTROL SYSTEM DESIGN

TOS/AMS THERMAL CONTROL SYSTEM HERITAGE

The thermal control subsystem heritage comes from flight-proven components. The table opposite lists various components of the TCS, previous applications and vendor sources. Although, the TCS elements are new, the materials, applications, attachment methods and basic analytic techniques are standard in the industry and are essentially those used and proven on the Titan IIIC Transtage.

Procurement lead times are not critical for any of the components. The fabrication and installation techniques for the gold plated stainless steel foil will be the same as used for the Titan Transtage propellant tanks. Further analysis will evaluate whether alternates to quartz cloth and min-k might be even more satisfactory.

TOS/AMS THERMAL CONTROL SYSTEM HERITAGE

QSC

MARTIN MARIETTA

Item	Quantity	Manufacturer	Part No.	Heritage	Added Qual	Space Proven
RCS Tank Heaters	4	TAYCO	STM Q215*	MMU, SCATHA, Viking	No	Yes
RCS Line Heaters	19	TAYCO	STM Q215*	MMU, SCATHA, Viking	No	Yes
RCS Valve Heaters	6	TAYCO	STM Q215*	MMU, SCATHA, Viking	No	Yes
Avionics Heaters	16	TAYCO	STM Q215*	MMU, SCATHA, Viking	No	Yes
Cradle Heaters	6	TAYCO	STM Q215*	MMU, SCATHA, Viking	No	Yes
Thermostatic Switches	48	Sundstrand	ST 71D26*	MMU, SCATHA, Viking	No	Yes
Quartz Cloth	10 ft ²	J. P. Stevens	Style 581*	DSCS	No	Yes
MIN-K	5 ft ²	Manville	No. 2000	—	No	—
Gold Plated Stainless Steel	100 ft ²	Burton Silver Plating	EPS 30006*	Transtage	No	Yes
MLI Blankets	2200 ft ²	Sheldahl	A569C, A568B, A569G*	MMU, SCATHA, Viking	No	Yes
Black TCS Paint	5 gal	Hughson Chemical	2306*, K702A	MMU, SCATHA, Viking	No	Yes
White TCS Paint	5 gal	Hughson Chemical	A276	IUS, Orbiter Pallet	No	Yes

*Denotes Martin Marietta Corporation Code

THERMAL CONTROL SYSTEM IS SPACE PROVEN

TOS/AMS GSE FOR TDRS

The tables opposite and on the following page list the individual MGSE along with the functional requirements and description. The MGSE must support, protect and provide for transport of the AMS, TOS/AMS and ASE during all phases of assembly, shipping, transfer and checkout. It must provide all of the necessary physical interface locations and meet all space envelope requirements. Strength and safety factors will be such that no critical loads are imposed on the flight structure. The payload lifting fixture which is illustrated, interfaces with that portion of the longeron trunnion pins which is designated for ground handling.

TOS/AMS GSE FOR TDRS

CSC

MARTIN MARIETTA

	<u>ITEM</u>	<u>REQUIREMENT/FUNCTION</u>
1	LIFTING SLING	HANDLES AMS SUPPORT FIXTURE, MBD PLATFORMS AND AUXILIARY PLATFORMS.
2	PROTECTIVE COVER MBD	PROVIDES TOS/AMS WITH PROTECTION AGAINST WEATHER & CONTAMINATION CONDITIONS DURING INTRASITE TRANSFER & STORAGE WHILE MOUNTED ON THE MBD
3	PROTECTIVE COVER SUPPORT, MBD	PROVIDES A SUPPORT FOR THE PROTECTIVE COVER & ESTABLISHES A SPACE ENVELOPE BETWEEN THE COVER AND TOS/AMS DURING MBD INTRASITE TRANSFER OR STORAGE
4	HANDLING KIT PROTECTIVE COVER/COVER SUPPORT, MBD	LIFTS & LOWERS THE MBD PROTECTIVE COVER AND COVER SUPPORT
5	CARRYING CASE ORDNANCE	PROVIDES CAPABILITY FOR TRANSPORT OF TOS, AMS & ASE ORDNANCE ITEMS
6	TRANSFER SYSTEM AIR BEARING, MBD	SUPPORTS & TRANSFERS THE MBD THROUGH THE VPF & RETURN TO THE AIRLOCK
7	PAYLOAD LIFTING FIXTURE	IN CONJUNCTION WITH THE VPF OVERHEAD CRANE, LIFTS THE COMPLETE PAYLOAD FROM THE MBD STAND FOR TRANSFER TO THE VPF CELL
8	WORK PLATFORM PORTABLE	PROVIDES ACCESS TO SIDES & UPPER AREAS OF PAYLOAD DURING ASSEMBLY & CHECKOUT
9	CRANE, PORTABLE FLOOR	LIFTS, LOWERS, INSTALLS AND REMOVES AMS COMPONENTS DURING ASSEMBLY AND CHECKOUT

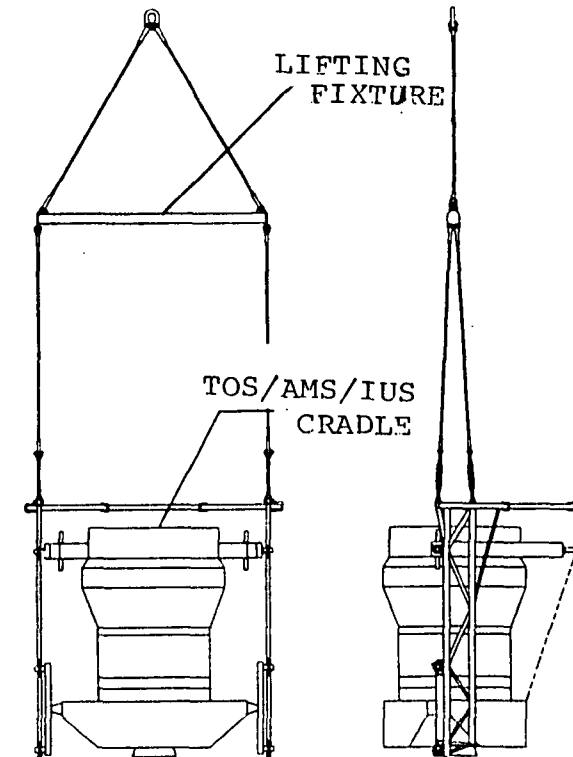

PAYLOAD LIFTING FIXTURE

TOS/AMS GSE FOR TDRS - CONCLUDED

The MGSE list is concluded on the opposite page. The Mobile Build-up Device (MBD), which is illustrated consists of two modified "lowboy" type highway trailers. When feasible, MGSE hardware is designed for multiple utilization. For example, the Number 11 Support Fixture is used as a storage, assembly and checkout stand, transport dolly and the transport container base. All of the GSE which is currently used in handling the IUS cradles will also be used on the TOS/AMS/TDRS program. Otherwise, the standard MGSE which is planned for the TOS/AMS vehicle is adequate to meet the TDRS spacecraft needs.

TOS/AMS GSE FOR TDRS - CONCLUDED



MARTIN MARIETTA

	ITEM	REQUIREMENT/FUNCTION
10	MOBILE BUILDUP DEVICE (MBD)	SUPPORTS THE TOS/AMS DURING BUILDUP/ASSEMBLY, SUPPORTS THE MATING OF A SPACECRAFT TO THE TOS/AMS & SUPPORTS THE TRANSPORT OF THE TOS/AMS/SPACECRAFT FROM HPF TO THE VPF
11	SUPPORT FIXTURE, AMS	SUPPORTS THE AMS & PROVIDES TRANSFER CAPABILITY FOR AMS IN TRANSIT (WHEN USED IN CONJUNCTION WITH TRANSPORT CONTAINER, AMS OR PROTECTIVE COVER, AMS & SHIPPING/LIFTING FIXTURE, AMS)
12	ACCESS STAND, AMS	PROVIDES ACCESS TO THE AMS ON THE SUPPORT FIXTURE DURING ASSEMBLY & CHECKOUT
13	TRANSPORT CONTAINER, AMS	USED IN CONJUNCTION WITH THE SUPPORT FIXTURE, PROVIDES SUPPORT & PROTECTION TO THE AMS DURING RAIL & TRUCK TRANSPORTATION OPERATIONS
14	ENVIRONMENTAL CONTROL SYSTEM, AMS	PROVIDES HEATED OR COOLED AIR TO THE MBD OR TRANSPORT CONTAINER, AMS
15	SHIPPING/LIFTING FIXTURE, AMS	PROVIDES SUPPORT TO AMS DURING TRANSPORT OPERATIONS & PROVIDES FOR HANDLING OF AMS BY ITS FORWARD RING
16	PROTECTIVE COVER, AMS	PROVIDES THE AMS WITH PROTECTION AGAINST WEATHER & CONTAMINATION CONDITIONS DURING INTRASITE TRANSFER & STORAGE ON THE SUPPORT FIXTURE, AMS
17	STORAGE STAND, TOS	SUPPORTS TOS AND/OR TOS/AMS DURING ASSEMBLY & INTRASITE TRANSFER

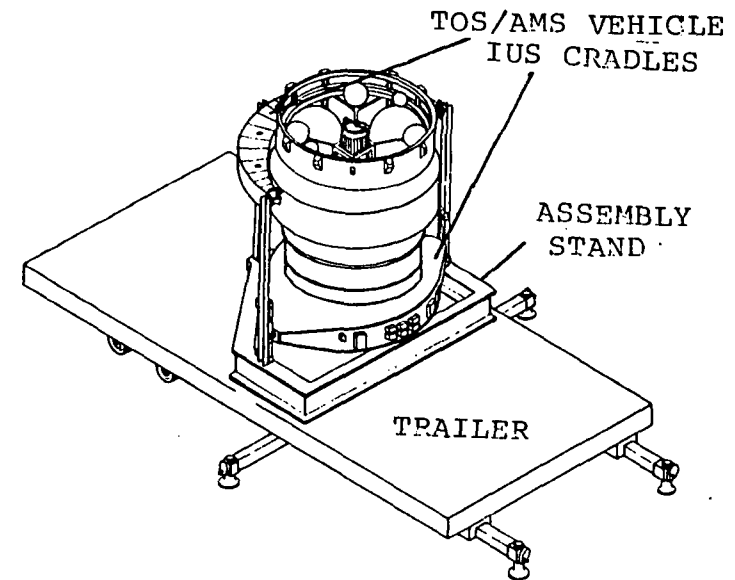

MOBILE BUILDUP DEVICE (MBD)

IUS CRADLE GSE IS USED.
NO NEW AMS MECHANICAL GSE
IS REQUIRED FOR TDRS



O5C

MARTIN MARIETTA

6.0 ORBITER SAFETY REQUIREMENTS

STS SAFETY REQUIREMENTS ASSESSMENT FOR TDRS

A comprehensive assessment was performed for TDRS application on TOS/AMS by first reviewing all safety related documentation for TDRS-A and TDRS-A on IUS. This review provided insight to TDRS unique safety issues and concerns. The activity continued with a specific assessment of potential safety requirements for the TOS/AMS/TDRS configuration. This assessment identified the potential need for one waver. The waver relates to the use of Raychem 44 wire insulation on TDRS since there is no current limiter once TDRS is on internal TOS/AMS vehicle power. This same situation exists on IUS.

Safety documents reviewed and evaluated for TOS/AMS application included "Accident Risk Assessment Report" (ARAR) "Approved flight safety hazard reports for TDRS-A", "Approved flight safety waivers for TDRS-A", NHB 1700.7A and KHB 1700.7A.

STS SAFETY REQUIREMENTS ASSESSMENT FOR TDRS

Osc

MARTIN MARIETTA

- o ASSESS SAFETY COMPATIBILITY - TASK 3.1.11

- o TDRS SAFETY FUNCTIONS PROVIDED BY IUS UPPER STAGE HAVE BEEN EVALUATED
 - ARAR REVIEWED - "IUS/TDRS INTERFACE SAFETY ANALYSIS REVISION B 15 DECEMBER 1982" - BOEING
 - REVIEWED - "APPROVED FLIGHT SAFETY HAZARD REPORTS FOR TDRS-A"
 - REVIEWED - "APPROVED FLIGHT SAFETY WAIVERS FOR TDRS-A"

- o RESULTS
 - POTENTIAL WAIVER FOR TDRS RAYCHEM 44 WIRE INSULATION (NO CURRENT LIMITER WITH INTERNAL VEHICLE POWER)

01126-34-JS

TOS/AMS SYSTEM SAFETY SUMMARY

The Safety status for TOS/AMS is summarized. The required phase 0 safety reviews for both JSC and KSC have been completed without action items.

Three safety issues have been identified. The first (IUS cradle separation velocity) is resolved by including RF command in the design. This enables the crew to inhibit the TOS/AMS sequencer. Two issues remain. The safe separation distance from the orbiter for activation of TOS RCS thrusters has been evaluated by Martin Marietta and reviewed by JSC safety. A memorandum from JSC to the safety panel recommends acceptance of the TOS proposed 255 ft. distance. This issue will be resolved for TOS/AMS upon acceptance by the safety panel of the TOS program recommendation.

The final issue associated with the use of Raychem 44 wire insulation on TDRS has resulted in the need for a waver on IUS and a potential waver on TOS/AMS.

TOS/AMS SYSTEM SAFETY SUMMARY

QSC

MARTIN MARIETTA

- o JSC PHASE 0 SAFETY REVIEW PASSED
 - NO ACTION ITEMS (JAN 31, 1984)

- o KSC PHASE 0 SAFETY REVIEW PASSED
 - NO ACTION ITEMS (APRIL 27, 1984)

- o IUS CRADLE SEPARATION VELOCITY
 - 0.5 FT/SEC NOMINAL/0.33 FT/SEC WORST CASE
 - REQUIRES RF COMMAND BY ORBITER CREW FOR TOS/AMS

- o SAFE SEPARATION DISTANCE FOR RCS ACTIVATION
 - TOS HAS VERBAL AGREEMENT FOR ACTIVATION AT 255 FT WITH 256 LBS THRUST
 - TOS/AMS PLANS TO MEET THE 255 FT AGREEMENT (WORST CASE 12.9 MINUTES)

- o POTENTIAL WAIVER FOR TOS/AMS BASED ON IUS
 - TDRS RAYCHEM 44 WIRE INSULATION

01126-33-JS