

N 84 - 3 1 6 8 4

NASA Technical Memorandum 86269

ACTIVE CONTROLS: A LOOK AT ANALYTICAL METHODS
AND ASSOCIATED TOOLS

J. R. NEWSOM, W. M. ADAMS, JR., V. MUKHOPADHYAY,
S. H. TIFFANY, AND I. ABEL

JULY 1984

NASA

National Aeronautics and
Space Administration

Langley Research Center
Hampton, Virginia 23665

ACTIVE CONTROLS: A LOOK AT ANALYTICAL METHODS AND ASSOCIATED
TOOLS

By J. R. Newsom, W. M. Adams, Jr., V. Mukhopadhyay,
S. H. Tiffany, and I. Abel
NASA Langley Research Center
Hampton, Virginia

Abstract

A review of analytical methods and associated tools for active controls analysis and design problems is presented. Approaches employed to develop mathematical models suitable for control system analysis and/or design are discussed. Significant efforts have been expended to develop tools to generate the models from the standpoint of control system designers' needs and develop the tools necessary to analyze and design active control systems. Representative examples of these tools are discussed. Examples where results from the methods and tools have been compared with experimental data are also presented. Finally, a perspective on future trends in analysis and design methods is presented.

Introduction

Active controls technology offers the potential for realizing economic and performance benefits from aircraft configurations that would be unacceptable by traditional design standards. Through interdisciplinary efforts, especially among controls specialists and aeroelasticians, a new concept is evolving for aircraft design in which both aircraft stability and structural integrity are dependent on the operation of an active control system. Because active controls analyses span the traditional disciplines of structural dynamics, aerodynamics (both steady and unsteady), propulsion (propulsion will not be considered in this paper), and control theory, a common format for the math models is required.¹ The integration of these traditional disciplines is maturing into a new discipline termed by many as aeroservoelasticity.

The analytical methods (both analysis and design) have been evolving for some time.²⁻⁹ In design, the problem is the synthesis of a control law that regulates the dynamics of the system such that measures of performance (e.g., stability, loads, transient response, etc.) are acceptable. In analysis, the control law already exists and analytical methods are employed to assess the performance of the overall controlled system.

To take full advantage of active control technology, control law synthesis and analysis must be an integral part of the aircraft design process. This requires efficient methods and accompanying tools that will enable the active controls designer routinely to synthesize and analyze complex control systems. A significant amount of work has been performed to develop analysis and synthesis methods and tools for this task. Much of the NASA active controls research

involvement has been at the forefront of these developments.

Since the validation of analytical methods is, as always, very important, several experimental studies have been performed to date.¹⁰⁻¹⁷ These experimental studies have ranged from wind-tunnel tests to subscale flight tests to full-scale flight tests. The majority of the wind-tunnel tests have emphasized flutter suppression whereas the majority of the flight tests have emphasized other active control concepts such as relaxed static stability, maneuver and gust load alleviation, etc.

The purpose of this paper is to describe the development and validation of analytical methods for application to active controls technology. Although various analytical methods will be mentioned, emphasis is given to the methods developed at the NASA Langley Research Center. A few representative examples of studies to correlate analysis and experimental data are presented. Finally, some future trends in analytical methods will be discussed.

Nomenclature

A_j	real aerodynamic approximation matrices
A, B_u, B_{wg}	plant matrices
A_c, B_c, C_c	controller matrices
A_a	augmented plant matrix
B_a	augmented input matrix
b	reference length
C	output matrix
C_{co}	control law optimum gain matrix
D_v	viscous damping matrix
E	expected value
$F(s)$	response transfer function matrix
$H(s)$	modal transfer function matrix
i	$\sqrt{-1}$
J	cost function
K_s	generalized stiffness matrix
k	reduced frequency, $b\omega/V$
L	Kalman filter gain matrix
M	generalized mass matrix
N_0	average no. of positive zero crossing
p	nondimensional Laplace variable, bs/V
Q	force vector function
Q_1, Q_2	weighting matrices
q	dynamic pressure
R_n	noise intensity matrix
s	Laplace operator
t	time
u	plant input vector
U	system input function vector

V	velocity
w _g	gust vector
w _m	measurement noise vector
X	vector of state variables
X _a	augmented state covariance matrix
X _c	vector of controller states
Y	output vector
Z(x,y,t)	vertical displacement at point (x,y) at time, t
β _j	aerodynamic lag terms
δ	control surface deflection
δ _A	actuator output
δ _{com}	actuator input
φ _j (x,y)	jth mode shape
φ _{wg} (ω)	gust input power spectrum
φ	phase angle
n	noise vector
σ	rms value
ω	circular frequency
ξ _j (t)	jth generalized coordinate vector
ζ	damping coefficient

Equations of Motion

Modeling the dynamics of an actively controlled flexible vehicle is a multidisciplinary task. Structural dynamics, unsteady aerodynamics, and control elements are required. Structural dynamics, unsteady aerodynamics, and control system interactions can be represented by second-order frequency domain or first-order state-space (time domain) equations. A flow chart which illustrates the development of these equations is shown in figure 1. A description of the development of the mathematical models follows.

Structural Dynamics

The structural dynamics for a flexible airplane can be formulated using Lagrange's equations.¹⁸ It is normally assumed that the dynamics can be represented by a finite number of modes. By the method of separation of variables, the motion is assumed to be the product of a shape function and a time function.

$$z(x,y,t) = \sum_{j=1}^N \phi_j(x,y)\xi_j(t) \quad (1)$$

If all of the structural damping in the aircraft is assumed to be viscous in nature, then the equations of motion can be written as

$$M\ddot{\xi} + D_V\dot{\xi} + K_S\xi = Q \quad (2)$$

The forces on the right hand side of equation 2 are a result of aerodynamic forces due to aircraft motion, turbulence, and control surface motions and forces due to actuator motions.

Unsteady Aerodynamic Forces

Unsteady aerodynamic forces are normally computed as tabular functions of Mach number and the complex variable $p=sb/V$. Programs currently available for production-generation of aerodynamic forces can only perform the computations for $p=\sqrt{-1}bw/V$.^{19,20} This is precisely the form required for frequency response computations or,

for stable systems, for computing a statistical measure of the response to random inputs. However, $Q(p)$ is needed for investigations of system stability. This point will be discussed further in a later section entitled "Stability."

The concept of analytic continuation⁶ can be employed to develop an approximation to the aerodynamic forces for arbitrary motion (i.e., a function of p) in terms of known aerodynamic forces for oscillatory data.^{1,4,6,21} The most widely used form is

$$A_0 + A_1p + A_2p^2 + \sum_{j=1}^L \frac{A_{j+2}p^2}{\beta_{j+1}p} \quad (3)$$

The real coefficients are determined, subject to any imposed constraints (e.g., A_0 associated with rigid-body linear displacement should be zero), such that the error between the approximation and the known tabular data is minimized (e.g., in a least squares sense)^{1,4,21}

The motivation for the rational approximation of equation 3 is to enable the equations of motion to be transformed to a set of constant-coefficient first-order differential equations that are amenable to analysis by efficient linear systems techniques. Such a transformation will be defined in a section entitled "State Space Equations of Motion."

Control System

Control system equations are normally described by transfer functions. Standard transformation techniques can be employed to transform the transfer function representation to a state-space representation. The general relationship between actuator outputs and inputs can be expressed as

$$\delta_A = \{T_A(s)K(s)T_S(s)C(s) + T_{HE}(s)H_E\} \xi + T_A(s)\delta_{com} \quad (4)$$

The definition of these matrices will be given in the next section.

Overall System

By combining the structural dynamics, unsteady aerodynamics, and control system representations, the equations of motion in the frequency domain (see figure 2a for a block diagram) can be written as

$$\{Ms^2 + D_Vs + K_S + qQ(\frac{sb}{V}) - F_D(T_{HS}(s)C(s) + T_{HE}(s)H_E)\} \xi = \frac{q}{V} Q_g w_g + F_D T_A(s) \delta_{com} \quad (5)$$

where

D _v	viscous damping coefficient
q	dynamic pressure
V	aircraft speed
b	reference length
p=sb/V	nondimensional Laplace variable

Q	generalized aerodynamic force
C(s)	input to sensor i resulting from motion in the jth generalized coordinate
H _E	N _ξ × N _ξ matrix of modal coefficients relating actuator displacement to generalized coordinates
T _{HS} (s)	N _ξ × N _ξ matrix relating actuator hinge moment outputs to sensor inputs. This matrix contains sensor, control logic, and actuator dynamics.
T _{HE} (s)	N _ξ × N _ξ matrix relating actuator hinge moment outputs to actuator displacements.
T _A (s)	N _ξ × N _ξ diagonal matrix of transfer functions relating actuator hinge moment outputs to actuator displacements
T _S (s)	N _ξ × N _ξ diagonal matrix of transfer functions relating sensor outputs to sensor inputs
F _D	N _ξ × N _ξ matrix of modal coefficients converting hinge moment outputs to generalized forces
δ _{com}	commanded (e.g., pilot) inputs to actuators
δ _A	outputs from actuators
w _g	gust velocity input

An alternate form of the equations often used for simplicity neglects aerodynamic hinge moments and hinge moments due to inertial coupling between control surface and basic wing degrees of freedom and also assumes infinite stiffness of the backup structure. In this case control surface deflections are given by

$$\delta = T_{\delta}(s)C(s)\xi + T_A(s)\delta_{com} \quad (6)$$

The dimension of δ is N_ξ × 1 and T_δ is a matrix of transfer functions relating control deflections to sensor inputs. The resulting equations can be expressed as

$$\begin{bmatrix} M_{\xi\xi}s^2 + D_{V\xi\xi}s + K_{S\xi\xi} + qQ_{\xi\xi}\left(\frac{sb}{V}\right) & M_{\xi\delta}s^2 + qQ_{\xi\delta}\left(\frac{sb}{V}\right) \\ T_{\delta}(s)C(s) & -I \end{bmatrix} \begin{Bmatrix} \xi \\ \delta \end{Bmatrix} = \begin{bmatrix} \frac{q}{V} Q_{wg} & q Q_{\xi\delta}\left(\frac{sb}{V}\right) \\ 0 & -T_A(s) \end{bmatrix} \begin{Bmatrix} w_g \\ \delta_{com} \end{Bmatrix} \quad (7)$$

State Space Equations of Motion. Under the assumption that the approximation in equation (3) is valid for points off the imaginary axis, linear time-invariant equations of motion can be written in the form (see figure 2b for a block diagram)

$$\dot{X} = AX + B_u u + B_{w_g} w_g \quad (8)$$

$$Y = CX + w_m$$

$$\dot{X}_C = A_C X_C + B_C Y \quad (9)$$

$$u = C_C X_C + u_{com}$$

where

$$X^T = \left\{ \xi^T \dots \xi^T X_{\beta_1}^T \dots X_{\beta_L}^T X_S^T X_A^T X_g^T \right\}$$

X _{β₁} ... X _{β_L}	n _L × n _ξ states associated with the unsteady aerodynamic force representation
X _S	states representing sensor dynamics transfer functions
X _A	states representing actuator transfer functions
X _g	gust states representing a filter which converts white noise input to a gust velocity having a power spectral density approximating atmospheric turbulence
u _{com}	commanded control inputs
w _g , w _m	uncorrelated zero mean, white noise processes with intensities R _g and R _m , respectively
X _C	states representing the control logic
A _C , B _C , C _C	matrices in state space representation of the control logic

Analysis Methods

Analysis consists of solving the equations of motion for quantities that provide information on the performance of the active control system. An actively-controlled flexible aircraft may require analysis of many different measures of performance. Figure 3 shows plots typical of those used to assess the performance of an active control system. All of these plots will probably be examined during the design of an active control system.

The analysis methods employed for an actively-controlled flexible aircraft can be divided into two major categories. The first category involves classical methods defined in this paper where the frequency-domain formulation of the equations of motion is used. The second category involves modern methods defined in this paper where the state-space formulation of the equations of motion is used. All of the quantities that are needed to assess the performance of an active control system can be found using either classical or modern methods. However, one method may be better suited to evaluate certain quantities. Techniques used in both categories of analysis methods will be described.

Classical Analysis Methods

As stated previously, classical analysis methods normally utilize the frequency domain formulation of the equations of motion. Equation 5 can be written as

$$\bar{H}(s)\xi = F(s)U \quad (10)$$

The $(\bar{\quad})$ represents a closed-loop quantity.

Stability. The unsteady aerodynamic force matrices are currently only calculated at $s=i\omega$. (Reference 22 describes an approach which would allow direct computation of $Q(s)$.) The availability of only $Q(i\omega)$ creates a problem in solving for the eigenvalues of $H(s)$. Two approximations are commonly employed to circumvent this difficulty.^{4,23}

One approximation, valid for lowly damped eigenvalues, is to assume

$$Q(s) \approx Q(0+i\omega) = Q(iV_k/b) \quad (11)$$

and approximate eigenvalues are found by using the p-k method.²³ When the p-k method is employed to solve

$$|\bar{H}(s)| = \det \bar{H}(s) = 0$$

$Q(ik)$ is a nonlinear, tabular function of k . Consequently, solutions can only be obtained by an iterative process.

The other approach is to make a rational s-plane approximation

$$\hat{Q}(s) = Q(s)$$

as in equation 3. Eigenvalue determination where one has $Q(s)=Q(V_p/b)$ is commonly termed the p-p method. When $Q(s)$ is employed, one may transform the equations of motion as in equation 8 into a standard eigenvalue form. Then the iterative p-p procedure and standard eigenvalue (state-space) methods produce identical results.

Figure 4 (from ref. 24) shows elastic mode eigenvalue loci as a function of feedback gain for a single-input-single-output control law. Curves are shown that were obtained by the p-k and the p-p methods. Differences between the loci found by the two methods increase as damping ratio increases. The slight difference at the flutter point is due to the fact that $\hat{Q}(i\omega)$ did not fit the $Q(i\omega)$ data precisely at the flutter frequency.

Robustness. The plant and controller input/output transfer matrices can be written as

$$Y = T(i\omega)C(i\omega)H^{-1}(i\omega)F(i\omega)U = G_\delta(i\omega)\delta_A + G_{wg} w_g$$

$$\delta_A = K(i\omega)Y + T_A(i\omega)\delta_{com} \quad (12)$$

Classical analysis techniques have, in the past, relied heavily upon Bode plots of particular elements of G_δ and K and also upon Nyquist plots of elements of the loop transfer matrix $G_\delta K$.

The classical formulation is also particularly well suited for analysis of the eigenvalues and singular values of the loop transfer and return difference matrices. In the classical formulation no s-plane approximation (with accompanying additional states) is needed and experimental frequency response data for dynamic elements such as actuators and sensors can be utilized directly without adding additional states to represent them. Use of the classical approach to perform

the singular value computations is described in reference 25.

Stochastic response. Classical analyses are typically performed to examine a statistical characterization of loads due to turbulence at critical locations in an aeroelastic structure.^{26,27} Historical data have been used to establish certain guidelines that, if followed, result in a safe structure. With the advent of active controls, these guidelines have been applied for closed-loop cases. The guidelines have been extended, somewhat arbitrarily, to establish statistical control power criteria.²⁸

If the gust input is a Gaussian random process, then two quantities, σ (the rms value) and N_0 (the average number of positive zero crossings), suffice to describe the output response to the turbulence excitation. These quantities can be written as

$$\sigma = \frac{1}{2\pi\sigma_{wg}} \left\{ \int_0^\infty |G_{wg}(i\omega)|^2 \phi_{wg}(\omega) d\omega \right\}^{1/2}$$

$$N_0 = \frac{1}{2\pi\sigma_{wg}} \left\{ \int_0^\infty \omega^2 |G_{wg}(i\omega)|^2 \phi_{wg}(\omega) d\omega \right\}^{1/2} \quad (13)$$

where ϕ_{wg} is the gust input power spectrum.

Deterministic response. As stated before, the unsteady aerodynamic matrices are calculated only for $s=i\omega$ (steady-state oscillatory motion) and the equations of motion are written in the frequency domain. Fourier transform techniques provide a method by which deterministic response can be obtained from the solution of the frequency domain formulation of the equations of motion.

Deterministic response analysis by Fourier transform techniques can be separated into three phases. First, the forcing function (defined in the time domain) is transformed into the frequency domain. Second, the responses are computed in the frequency domain. Third, the responses (in the frequency domain) are transformed back to the time domain. Reference 29 gives a complete description of this method to calculate deterministic responses.

Modern Methods

The commonly conducted analyses using the state-space representation include block-diagonalization, controllability and observability, eigenvalue/eigenvector, covariance, frequency response, time response, and robustness.

The matrix A (eq. 8) is normally a highly coupled matrix. The coupling is due to presence of the aerodynamics and actuator dynamics. A linear transformation can be used⁹ to transform the system to block diagonal form. The diagonal blocks are composed of the real and imaginary parts of the eigenvalues of each mode. The transformed B and C matrices provide information regarding the degree of controllability and observability of each state.

The characteristic roots of the system can be obtained by computing the eigenvalues of the matrix A and may be plotted for varying dynamic pressures or other parameters to provide root loci or parametric stability information. No

determinant iteration is required (unlike the p-k or p-p methods).

For a stable system the root mean square (rms) response to a stationary white noise input $\eta(t)$ is obtained using covariance analysis.³⁰ The computation involves solution of a steady-state Lyapunov equation

$$A_a X_a + X_a A_a^T + B_a R_a B_a^T = 0 \quad (14)$$

where X_a is the covariance matrix of the augmented state vector $\begin{bmatrix} X \\ X_c \end{bmatrix}$ and R_a is the noise intensity matrix. The square root of the diagonal terms of the X_a matrix are the rms values of each state. In classical analysis, the rms values are obtained by numerically integrating the power-spectral density over a finite-frequency domain.

The time response to a deterministic input $u(t)$ is given by

$$X(t) = e^{A(t-t_0)} X(t_0) + \int_{t_0}^t e^{A(t-\tau)} B u(\tau) d\tau \quad (15)$$

The computation of the state transition matrix e^{At} can be facilitated by block diagonal transformation of the matrix A . For certain $u(t)$ time histories, the time integration can be performed analytically.

Design Methods

A flow chart of the overall control law design process is shown in figure 5. The first element of the process is the selection of design objectives (i.e., stability margins, maximum allowable structural and control loads, etc.). The second element is the selection of a design point (i.e., Mach number and altitude). The third element is the synthesis of the control law. There are several approaches to this key element in control law design. Among the approaches are classical control theory, modern control theory, numerical optimization methods, the method of constraints³¹, least-squares synthesis³², and the aerodynamic energy method.⁸ The first three approaches to this key element will subsequently be discussed. The next element, analysis, provides information on the performance of the control law at off-design conditions. If the design objectives are not met, then a gain scheduler, which may be a function of Mach number and/or dynamic pressure, is evaluated. If use of a gain scheduler will still not result in meeting the design objectives, the control law synthesis element is reentered.

Classical methods. Classical design techniques based on root locus or Bode plots have been applied primarily to single-input-single-output (SISO) problems or to multi-input-multi-output (MIMO) problems where the coupling between loops was sufficiently weak to allow the design to be treated as a sequence of single-loop problems. In such cases, the classical techniques allow direct manipulation of loop gain margins, phase margins, etc. Recent classical MIMO design technique development includes the characteristic loci approach³³ and design in a transformed domain where input/output pairs are approximately

decoupled.³⁴ Stable nominal closed-loop systems can be obtained using these approaches. However, additional computations are required to quantify robustness characteristics. Tests have been identified³⁵ which involve both principal gains (singular values) and principal phases of the loop transfer matrix. These tests are less conservative than robustness tests based solely upon singular values.

Recently, classical (input/output) approaches which utilize fractional representation theory³⁶ have been developed which allow a parametric definition of the class of all stabilizing controllers for a given plant. Thus one can be assured while varying the free controller parameters to seek a more desirable subset, that the stability of the nominal closed-loop system is preserved.

Modern methods. The most popular modern control theory method is the Linear Quadratic Gaussian (LQG) method.³⁷ Because of the high order of the model for a flexible aircraft, a modification of the basic LQG method was developed.^{9,38} A block diagram of the Modified LQG design method is shown in figure 6. After a state-space model is generated, the first step in this approach is a full-state feedback design. Full-state feedback provides for the minimization of a quadratic cost function of the output and control vectors. To find the optimal full-state feedback control law, the quadratic cost function

$$J = E [X^T Q_1 X + u^T Q_2 u] \quad (16)$$

is minimized. This leads to a control law of the form

$$u = -C_{CO} X \quad (17)$$

where C_{CO} is the full-state feedback gain matrix.³⁰ Direct measurement of all state variables of an aeroelastic system is not feasible. Therefore, in the next step, a Kalman estimator is used to estimate the state variables from available measurements.

The estimator dynamics are given by

$$\dot{X}_c = [A - B_u C_{CO} - LC] X_c + LY \quad (18)$$

where L is the Kalman estimator gain matrix.³⁰ However, systems designed using a Kalman estimator can have poor gain and phase margins and an undesirable high bandwidth. To improve the stability margins during the estimator design, the "input noise" procedure of Doyle and Stein³⁹ can be used.

Equations (17) and (18) (with X replaced by its minimum variance estimate X_c) constitute the optimal controller which has the same order as the plant model used for the synthesis. As stated previously, in the case of a flexible airplane model that contains a large number of structural modes, unsteady aerodynamic lag states, and actuator states, the high order of the optimal controller imposes an unnecessary implementation burden. Several sources^{9,25,27,38,40,41} have shown that a reduced-order controller that approximates the full-order optimal controller can be found and used with little degradation in the closed-loop performance.

The transformation of the controller to block diagonal form can be used to help select the states that are to be retained during the controller reduction process. A modal residualization technique⁹ can be used to reduce the order of the controller.

The reduced-order controller is then analyzed with an evaluation model to examine its performance. If the design objectives are not met, then there are three paths that can be taken. A different set of design variables/controller order can be selected, the noise intensities can be changed, or the weighting matrices can be changed and the optimization and analysis steps repeated. The selection of which path to take is based on engineering judgment.

Numerical Optimization Method. A block diagram of the numerical optimization method is shown in figure 7. The objective of controller design is to provide a closed-loop system that meets performance specifications. It is natural, therefore, that the process be initiated by stipulation of the design objectives. These objectives can be expressed as inequality constraints on variables such as singular values of the return difference matrix, control position and rate limits, loads, etc.^{27,42,43}

The powerful LQG methodology can be employed to obtain a candidate stabilizing full-order controller. In this phase of the design effort a state space model of the plant is employed. It should be noted that the plant may contain augmented states associated with control logic introduced to satisfy part of the design criteria. At this point one may choose either to refine the design within the MLQG block described in the previous section or to exit this block with a candidate reduced-order controller.

The next step is to select parameters in the controller which may be employed as design variables (e.g., poles and zeroes or coefficients of polynomials). One may wish to express the controller as a matrix of transfer functions since a state space representation is not essential in the remaining blocks of this synthesis method. Note the alternate path to this point which admits the possibility of beginning with a given controller form to be specified by the designer. The alternate path might be selected to modify an existing controller when the plant has changed or to develop a scheduling for selected controller variables to improve performance at off-design conditions.

The analysis of controller performance for a given set of values of the design variables can be performed by using both classical and state space methods. In the former case, one can avoid the s-plane approximation, directly utilize experimental frequency response representations of dynamic elements, and more readily include the evaluation model in robustness assessments. In the latter case, one can more reliably obtain eigenvalues if they are needed to evaluate explicit constraints: the state-space formulation may allow more efficient computation of statistical or deterministic dynamic response characteristics. State-space formulations are also more suitable for analytic computations of

the sensitivities of constraint variables to variations of controller design parameters.

The search for a satisfactory controller can be automated by using a nonlinear programming algorithm^{44,45,46} to determine how to increment the design variables. The search proceeds iteratively and, if a design which satisfies the criteria is found, the process is terminated. It admits explicit consideration of the criteria within the design algorithm. If the iterative search fails to achieve the design objectives, one must try alternate design variables, or modify the controller form or relax the design criteria or some combination thereof.

Tools

Significant effort at the NASA has been applied toward developing tools to help the active controls designer in the synthesis and analysis of complex active control systems. These efforts have resulted in the development, either by the NASA or under the NASA sponsorship, of a number of computer programs. Three of these programs will be described in some depth and several others will be identified.

Analysis Tools

ISAC - Interaction of Structures, Aerodynamics and Controls. To facilitate the analysis of active control systems, it is necessary to describe numerically, the interaction between structural, aerodynamic, and control forces. This interaction is described in terms of stability and response characteristics. This capability, in the form of a computer program system, has been assembled and packaged and is identified by the acronym ISAC.⁴⁷ The system is in reality an assembly of several programs tied together through a common data complex as shown in figure 8.

An analysis proceeds from modal characteristics obtained separately by any suitable vibration analysis program to the aero/structure interface (DLIN in figure 8) where modal deflections and slopes are calculated at points required by a subsonic doublet lattice code.⁴⁸ Generalized aerodynamic forces for purely oscillatory motion are then computed as a function of reduced frequency and Mach number by using the doublet lattice code (DLAT in figure 8). Alternatively, both the aero/structure interface and the doublet lattice code may be bypassed and unsteady aerodynamic forces may be input (through the Data Complex Manager (DCM) in figure 8) from another source.

The equations of motion are represented in either the frequency domain or state-space formulation. Sensor, actuator, and controller dynamics can be characterized either in terms of transfer matrices or a corresponding state-space representation. Four basic types of dynamic response (DYNARES in figure 8) analyses can be performed within ISAC - stability, stochastic response, deterministic response, or frequency response.

An automated capability to determine eigenvalue loci as a function of altitude, density, velocity, or gain is included in the

stability analysis. If the frequency domain formulation is being employed, the loci are obtained either by a determinant or a matrix iteration process with $Q=Q(ik)$ (p-k method) or $Q=Q(p)$ (p-p method). This allows specific roots of interest to be traced. In the state-space formulation, a standard eigenvalue problem is solved. Zeroes may be calculated by standard root determination of the output transfer functions in the frequency domain formulation or by solving a generalized eigenvalue problem in the state space formulation.

Examples of the stochastic responses obtainable are output rms values for loads, control rates and deflections, and sensors due to a unit rms input gust velocity or control deflection. Power spectral density plots of the outputs also may be generated. Output sensitivities to changes in specified parameters such as control logic filters may be obtained by approximate finite differencing in the frequency domain formulation. The sensitivities may be obtained by closed form partial differentiation of steady-state covariance performance indices in the state-space formulation.⁴⁰

Output and state time history response due to a deterministic input such as a discrete gust or a step control input may be obtained. In the frequency domain formulation, this is accomplished by computing the inverse fast Fourier transform of the output Fourier transform of interest. In the state-space formulation, this can be accomplished using a block diagonal form of the transition matrix and a convolution integral.

Performance, stability, and robustness characteristics may be determined for both SISO and MIMO systems by frequency domain computations. Gain and phase margins as well as stability can be obtained for the SISO control system from traditional Nyquist and/or Bode plots. Analogous MIMO stability, performance, and robustness information may be determined from certain singular value and generalized Nyquist plots. Computations of eigenvalues and minimum and maximum singular values of the return difference and loop gain transfer matrices may be obtained from either the frequency domain or state-space formulation of the system. Frequency responses of these variables as well as other outputs of interest may be displayed graphically.

DYLOFLEX - Dynamic Loads of Flexible Airplanes with Active Controls. DYLOFLEX⁴⁹ is a system of computer programs which performs dynamic loads analyses of flexible airplanes with active controls. DYLOFLEX employs the frequency domain formulation of the equations of motion. The doublet lattice method is employed for calculation of the aerodynamic forces. The loads equations in DYLOFLEX are developed using the method of summation of forces. DYLOFLEX incorporates a range of analysis capabilities which include calculating dynamic loads due to continuous atmospheric turbulence, discrete gusts, and discrete control inputs. The output of DYLOFLEX consists of statistical quantities of the dynamic loads and time histories of the dynamic loads. The active control system equations are

incorporated by adding rows and columns to the basic second-order equations of motion. Therefore, all of the active control equations have to be expressed as second-order (or less) equations.

NASTRAN - NASA Structural Analysis Program. The capability to perform analyses of an actively-controlled flexible airplane was added to the NASTRAN program in 1979.²⁹ NASTRAN employs the frequency domain formulation of the equations of motion. Four different methods are available for the calculation of the aerodynamic forces. These include the doublet lattice method, strip theory method, Mach box method, and piston theory method. The different analyses available include flutter analyses, transient response, and random response analyses. Active control system equations are incorporated in a similar manner as DYLOFLEX where they must be expressed as second-order (or less) equations.

Synthesis Tools

- SYNPAC/PADLOCS - Synthesis Programs for the Design of Active Controls
- SYNPAC - Synthesis Package for Active Controls
- PADLOCS - Program for the Analysis and Design of Linear Optimal Control Systems

PADLOCS and SYNPAC are two packages of programs which have been developed at the NASA-Langley to facilitate the synthesis of control laws. Both the MLQG and constrained optimization techniques described previously are available in these programs. Both PADLOCS and SYNPAC rely heavily on ORACLS⁵⁰ software for the LQG portion of the design. Both systems of programs can be used to perform nonlinear constrained optimization studies to seek an implementable reduced-order controller which meets a set of design criteria. The design criteria are included as inequality constraints. Various parameters such as rms control rates and minimum singular values may be included in a weighted performance index.

The SYNPAC system makes direct use of ISAC as shown in figure 9. SYNPAC and ISAC share a common data base and data base manager, and the DYNARES module of ISAC is employed to perform the analyses. Consequently, the constrained optimization portion of SYNPAC can utilize either a frequency domain or state-space representation of the plant and controller. Stability can be constrained within SYNPAC either by eigenvalue computations or by computing the number of encirclements of the -1 point in a generalized Nyquist diagram. Also in SYNPAC, constraints on parameters such as short period damping may be included. The performance index is a weighted sum of the squares of the magnitudes of selected outputs, augmented by one of several types of penalty functions which incorporate the constraint violations. The user may select from a non-gradient⁵¹ or several conjugate gradient based nonlinear programming algorithms⁴⁵ to perform the constrained optimization. In actual application, only the nongradient based algorithm has been employed. Consequently, no effort has been expended to develop efficient code for gradient

computations; currently, gradients are computed numerically by finite differences. SYNPAAC has been employed in several control law design studies.^{25,27}

A flow chart for the PADLOCS program is shown in figure 10. PADLOCS requires a state-space representation of the plant and controller. Plant matrices ($[A]$, $[B_u]$, $[B_{wg}]$, and $[C]$ in eq. 8), which could be developed by ISAC are accepted as input to PADLOCS. A feasible directions, conjugate gradient algorithm is employed by PADLOCS to optimize a candidate reduced-order controller. Closed-form expressions for the gradient information are coded in PADLOCS for constraint and function variables involving output rms and return difference singular values. Stability is examined at each iterative step by solving for the eigenvalues. The PADLOCS system has been employed to design a number of active control laws.^{41,43}

Comparison of Analysis With Experiment

Active control experiments (wind tunnel and flight) have been used to validate analysis, to evaluate feasibility, and to demonstrate predicted benefits. A description of the wind tunnel and flight experiences to date with active controls is given in reference 52. The majority of the wind-tunnel experiments have focused on flutter suppression. Flight experiments have concentrated on the other active control concepts. A few representative examples of these tests will be described where analytical results have been compared with experimental data.

Wind tunnel.

The wind-tunnel example is a DC-10 derivative model that is described in reference 53. The model was designed to be tested in a low speed wind tunnel and therefore no transonic effects were present. One of the purposes of the tests was to assess the accuracy of dynamic analysis methods applied to the active control functions of flutter suppression and gust load alleviation. During the tests, parametric variations of control law gain and phase were made and experimental data were gathered. Figure 11 shows a comparison between the experimental and predicted stability boundaries as a function of gain and phase. Figure 12 shows a comparison between experimental and predicted gust loads as a function of gain and phase. The stability boundary predictions employed the state-space formulation for the equations of motion whereas the gust loads predictions employed the frequency domain formulation. The comparison of predicted and experimental results indicated that all stability and gust loads trends (in terms of gain, phase, and velocity) were predicted properly and that the analysis gave realistic estimates of levels.

Flight

Two flight tests of active control concepts that involve significant structural response will be discussed. The first is NASA's DAST (Drones for Aerodynamic and Structural Testing) program which is a research program whose primary objective is to develop and evaluate active control analysis and synthesis techniques. The second is the ALDCS (Active Load Distribution Control System) which is now an operational active

control system on the C-5A fleet designed to reduce wing loads.

A description of both the analytical and flight test data for the DAST vehicle is given in reference 54. A comparison of both frequency and damping of the dominant mode is shown in figure 13. The analysis and experimental data are for an altitude of 15,000 feet. The change in frequency with Mach number is predicted well for both the FSS-off and FSS-on cases. However, analysis overpredicts the damping for both the FSS-off and FSS-on cases. The experimental flutter speed is extrapolated to be approximately $M = 0.80$ for the FSS-off case. An actual flutter point was encountered for the FSS-on case at $M = 0.82$. The analysis overpredicts the FSS-off flutter speed by 4 percent and overpredicts the FSS-on flutter speed by 2 percent.

A description of the C-5A ALDCS is given in reference 15. Two examples of the comparison between analysis and experimental data are taken from reference 15. Figure 14a shows the amplitude of wing root bending moment frequency response function. The flight condition is 300 knots at an altitude of 25,000 feet. There is good agreement between analysis and experiment for both ALDCS-off and ALDCS-on cases. Figure 14b shows a comparison between analysis and experimental data for the spanwise distribution of incremental maneuver bending moment. The flight condition is a Mach number of 0.78 and an altitude of 30,000 feet. Again, there is good agreement between the analysis and experimental data.

Future Trends

The following is a brief discussion of the authors' perspective on future trends in analytical methods. These items are by no means exhaustive but are only considered to be representative.

Since the critical speed range for flutter is often transonic and the use of supercritical airfoils is increasing, the interfacing of the new nonlinear transonic unsteady aerodynamic force computations with structural dynamics and control system equations will become increasingly important.⁵⁵ The interfaces will be needed for both analysis and control law synthesis. In the control system design area, future emphasis will be on functionally integrated control system design for total mission control. In the robust control law synthesis area, the generalization of the structured singular value problem⁵⁶, optimal projection⁵⁷ and constrained optimization methods for fixed-order control law synthesis for both continuous and sampled-data systems will be gaining more attention.

Concluding Remarks

Analytical methods employed in active controls analyses and design have been described. Development of the math models from the basic frequency domain equations of motion to the state-space equations of motion have been discussed. Both classical and modern control techniques, as applied to the active controls problem, have been

reviewed. A combination of these techniques has been receiving considerable attention recently. Tools that implement these techniques have been described. Future trends toward functionally integrated control design, sampled-data techniques, robust control law synthesis techniques, and the incorporation of transonic unsteady aerodynamics have been identified. Examples where analytical results have been compared with experimental data have been presented. For these examples, the comparisons have been quite good. However, for these examples, the math models employed for the control law design have had the benefit of previous experimental results. The advances that have occurred in analytical methods are allowing certain nonflight-critical active control functions to be considered during aircraft preliminary design. However, considerable work remains to be done before math models can be used with the necessary confidence for flight-critical active control functions.

References

- 1 Roger, Kenneth L.: Airplane Math Modeling Methods for Active Control Design. Structural Aspects of Active Controls, AGARD-CP-228, Aug. 1977, pp. 4-1--4-11.
- 2 Severt, F. D.: Development of Active Flutter Suppression Wind-Tunnel Testing Technology. AFFDL TR-74-126, USAF, Jan. 1975.
- 3 Konar, A. F.; Stone, C. R.; Mahesh, J. K.; and Hank, M.: Active Control Synthesis for Flexible Vehicles. Vol. I - KONPACT Theoretical Description. AFFDL TR-75-146, USAF, June 1976.
- 4 Abel, I.: An Analytical Technique for Predicting the Characteristics of a Flexible Wing Equipped With an Active Flutter Suppression System and Comparison With Wind-Tunnel Data. NASA TP-1367, Feb. 1979.
- 5 Wykes, J. H.: Structural Dynamic Stability Augmentation and Gust Alleviation of Flexible Aircraft. AIAA Paper 68-1067, Oct. 1968.
- 6 Vepa, R.: Finite State Modeling of Aeroelastic Systems. NASA CR-2770, 1977.
- 7 Edwards, J. W.: Unsteady Aerodynamic Modeling and Active Aeroelastic Control. Stanford University Report, SUDAAR-504, Feb. 1977.
- 8 Nissim, E.: Flutter Suppression Using Active Controls Based on the Concept of Aerodynamic Energy. NASA TN D-6199, 1971.
- 9 Gangsaas, D.; and Ly, U.: Application of a Modified Linear Quadratic Gaussian Design to Active Control of a Transport Airplane. AIAA Paper 79-1746, August 1979.
- 10 Burris, P. M.; and Gender, M. A.: Aircraft Load Alleviation and Mode Stabilization (LAMS). AFFDL TR-68-158, April 1969.
- 11 Roger, K. L.; Hodges, G. E.; and Felt, L.: Active Flutter Suppression - A Flight Test Demonstration. J. of Aircraft, Vol. 12, No. 6, 1975.
- 12 Sandford, M. C.; Abel, I.; and Gray, D.: Development and Demonstration of a Flutter-Suppression System Using Active Controls. NASA TR R-450, Dec. 1975.
- 13 Hwang, C.; Winther, B. A.; and Mills, G. R.: Demonstration of Active Wing/Store Flutter-Suppression Systems. AFFDL Technical Report TR-78-65, June 1978.
- 14 Murrow, H. N.; and Eckstrom, C. V.: Drones for Aerodynamic and Structural Testing (DAST)--A Status Report. J. Aircraft, Vol. 16, No. 8, Aug. 1979.
- 15 Disney, T. E.: C5A Load Alleviation, Active Controls in Aircraft Design. AGARDograph No. 234, Nov. 1978.
- 16 Stauffer, W. A.; Foss, R. L.; and Lewolt, J. G.: Fuel Conservative Subsonic Transport. AGARD-ograph No. 234, Nov. 1978.
- 17 Guinn, W. A.: Development and Flight Evaluation of an Augmented Stability Active Controls Concept. NASA CR-165951, Sept. 1982.
- 18 Bisplinghoff, R. L.; and Ashley, H.: Principles of Aeroelasticity. John Wiley and Sons, Inc., New York, 1962.
- 19 Albano, Edward; and Rodden, W.: A Doublet-Lattice Method for Calculating Lift Distributions on Oscillating Surfaces in Subsonic Flow. AIAA J., Vol. 7, No. 2, Feb. 1969.
- 20 Rowe, W. S.; Winther, B. A.; and Redman, M. C.: Unsteady Subsonic Aerodynamic Loadings Caused by Control Surface Motions. J. Aircraft, Vol. II, No. 1, Jan. 1974.
- 21 Dunn, H. J.: An Analytical Technique for Approximating Unsteady Aerodynamics in the Time Domain. NASA TP-1738, Nov. 1980.
- 22 Morino, L.: A General Theory of Unsteady Compressible Potential Aerodynamics. NASA CR-2464, 1974.
- 23 Hassig, H. J.: An Approximate True Damping Solution of the Flutter Equation by Determinant Iteration. J. Aircraft, Vol. 8, No. 11, Nov. 1971.
- 24 Adams, W. M.; Tiffany, S. H.; Newsom, J. R.; and Peele, E. L.: STABCAR--A Program for Finding Characteristic Roots of Systems Having Transcendental Stability Matrices. NASA TP-2165, 1984.
- 25 Adams, W. M.; and Tiffany, S. H.: Design of a Candidate Flutter Suppression Control Law for DAST ARW-2. AIAA Paper No. 83-2221, Aug. 1983.
- 26 Pratt, K. G.: Response of Flexible Airplanes to Atmospheric Turbulence. Performance and Dynamics of Aerospace Vehicles, NASA SP-258, 1971, pp. 439-503.
- 27 Adams, W. M.; and Tiffany, S. H.: Control Law Design to Meet Constraints Using SYNPA--Synthesis Package for Active Controls. NASA TM 83264, Jan. 1982.

- 28 Visor, O. E.; and Severt, F. D.: Preliminary Design Study of a Flutter Suppression Control System for BQM-34E/F Drone Aircraft with a Supercritical Wing--Final Report. NASA CR-145208, 1976.
- 29 Rodden, W. P.; Harder, R. L.; and Bellinger, E. D.: Aeroelastic Addition to NASTRAN. NASA CR-3094, March 1979.
- 30 Kwakernaak, H.; and Sivan, R.: Linear Optimal Control Systems. John Wiley & Sons, Inc. 1972.
- 31 Radovcich, N. A.; and Richman, R.: Active Control Synthesis by Method of Constraints Using Large Order Dynamic Models. AIAA Paper 81-0642, April 1981.
- 32 Johnson, E. H.: Active Flutter Suppression Control Law Definition Via Least Squares Synthesis. AIAA Paper 80-0765, May 1980.
- 33 MacFarlane, A. G. J.: Multivariable Nyquist-Bode and Multivariable Root-Locus Techniques. Proc. IEEE Conf. on Decision and Control, pp. 342-347, 1976.
- 34 MacFarlane, A. G. J.; and Kouvaritakis, B.: A Design Technique for Linear Multivariable Feedback Systems. Int. J. Control, Vol. 23, pp. 837-874, 1977.
- 35 Postlethwaite, I.; Edmunds, J. M.; and MacFarlane, G. J.: Principal Gains and Principal Phases in the Analysis of Linear Multivariable Feedback Systems. IEEE Trans. Auto. Control., Vol. AC-26, No. 1, pp. 32-46, Feb. 1981.
- 36 Nett, C. N.; Jacobson, C. A.; and Balas, M. J.: Fractional Representation Theory: Robustness Results with Application to Finite Dimensional Control of a Class of Linear Distributed Systems. Proc. IEEE Controls and Decision Conference, 1983.
- 37 Athans, M.: The Role and Use of the Stochastic Linear-Quadratic-Gaussian Problem in Control System Design. IEEE Trans. Autom. Control. Vol. AC-16, No. 6, Dec. 1971, pp. 529-552.
- 38 Mahesh, J. K.; Stone, C. R.; Garrard, W. L.; Dunn, H. J.: Control Law Synthesis for Flutter Suppression Using Linear Quadratic-Gaussian Theory. J. Guidance and Control, Vol. 4, No. 4, July-August 1981, pp. 415-422.
- 39 Doyle, J. C.; and Stein, G.: Robustness with Observers. IEEE Trans. Autom. Control, Vol. AC-24, No. 4, Aug. 1979, pp. 607-611.
- 40 Mukhopadhyay, V.; Newsom, J. R.; and Abel, I.: A Method for Obtaining Reduced-Order Control Laws for High-Order Systems Using Optimization Techniques. NASA TP-1876, August 1981.
- 41 Newsom, J. R.; Pototzky, A. S.; and Abel, I.: Design of the Flutter Suppression System for DAST ARW-1R - A Status Report. NASA TM 84642, March 1983.
- 42 Schy, A. A.; Adams, W. M.; and Johnson, K. G.: Computer-Aided Design of Control Systems to Meet Many Requirements. Proc. of NATO AGARD (No. 137) Conference on Advances in Control Systems, 1973.
- 43 Newsom, J. R.; and Mukhopadhyay, V.: Application of Constrained Optimization to Active Control of Aeroelastic Response. NASA TM 83150, June 1981.
- 44 Fletcher, R.; and Powell, M. J. D.: A Rapidly Convergent Descent Method for Minimization. Computer J., Vol. 6, No. 2, July 1963.
- 45 Vanderplaats, G. N.: CONMIN-A FORTRAN Program for Constrained Function Minimization--User Manual. NASA TM X-62282, Aug. 1973.
- 46 Nelder, J. A.; and Mead, R.: A Simplex Method for Function Minimization. The Computer J., Vol. 7, 1965, pp. 308-313.
- 47 Peele, E. L.; and Adams, W. M., Jr.: A Digital Program for Calculating the Interaction Between Flexible Structures, Unsteady Aerodynamics and Active Controls. NASA TM 80040, 1979.
- 48 Giesing, J. P.; Kalman, T. P.; and Rodden, W. P.: Subsonic Unsteady Aerodynamics for General Configurations, Part I, Vol. I--Direct Application of the Nonplanar Doublet-Lattice Method. AFFDL-TR-71-5, Nov. 1971.
- 49 Perry, B., III; Kroll, R. I.; Miller, R. D.; and Goetz, R. C.: DYLOFLEX: A Computer Program for Flexible Aircraft Flight Dynamic Loads Analyses with Active Controls. J. Aircraft, Vol. 17, No. 4, April 1980, pp. 275-282.
- 50 Armstrong, E. S.: ORACLS--A System for Linear-Quadratic-Gaussian Control Law Design. NASA TP-1106, 1978.
- 51 Olsson, D. M.: A Sequential Simplex Program for Solving Minimization Problems. J. of Quality Technology, Vol. 6, No. 1, Jan. 1974, pp. 53-57.
- 52 Hanson, P. W.: An Aeroelastician's Perspective of Wind-Tunnel and Flight Experiences with Active Control of Structural Response and Stability. NASA TM 85761, May 1984.
- 53 Abel, I.; Perry, B., III; and Newsom, J. R.: Comparison of Analytical and Wind-Tunnel Results for Flutter and Gust Response of a Transport Wing with Active Controls. NASA TP-2010, June 1982.
- 54 Newsom, J. R.; and Pototzky, A. S.: Comparison of Analysis and Flight Test Data for a Drone Aircraft with Active Flutter Suppression. AIAA Paper No. 81-0640, April 1981.
- 55 Yang, T. Y.; and Batina, J. T.: Transonic Stability and Response of Conventional and Supercritical Airfoils Including Active Controls. AIAA Paper No. 84-0873, May 1984.
- 56 Doyle, J. C.; Wall, J. E.; and Stein, G.: Performance and Robustness Analysis for Structured Uncertainty. Proc. 1982 IEEE Conference on Decision and Control, Dec. 1982, pp. 629-636.

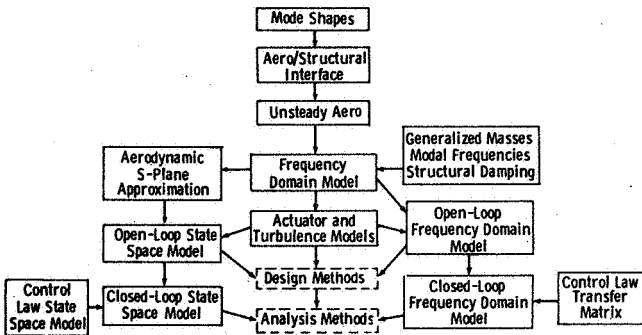

FIGURE 1. Flow Chart of Math Model Development

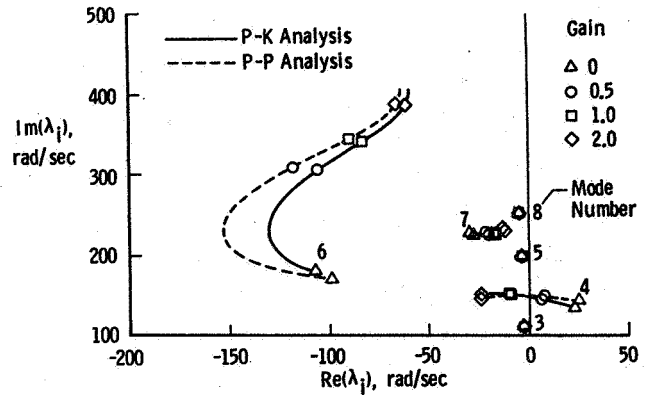

FIGURE 4. Comparison of p-k and p-p Techniques for Determining Stability

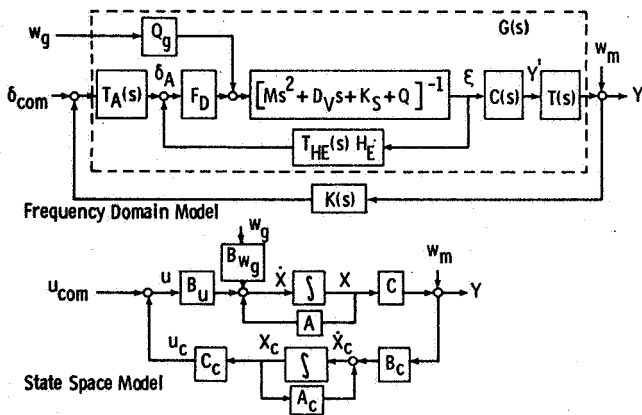

FIGURE 2. System Block Diagrams

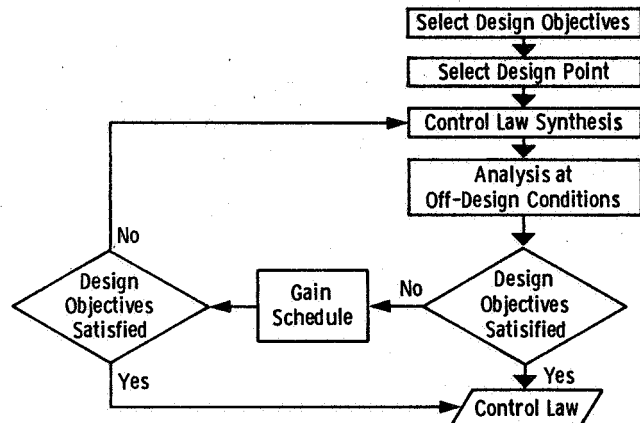

FIGURE 5. Flow Chart of Overall Control Law Design Process

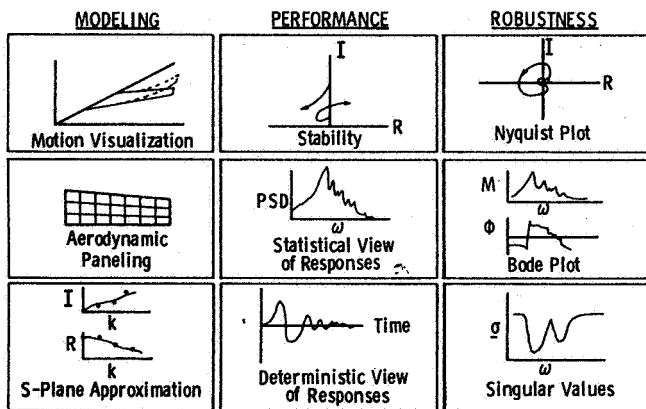

FIGURE 3. Typical Plots Used in Analysis of Active Control Laws

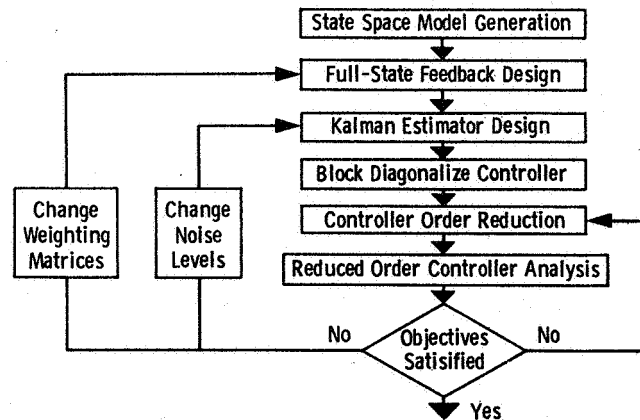

FIGURE 6. Flow Chart of Modified Linear Quadratic Gaussian Synthesis Technique

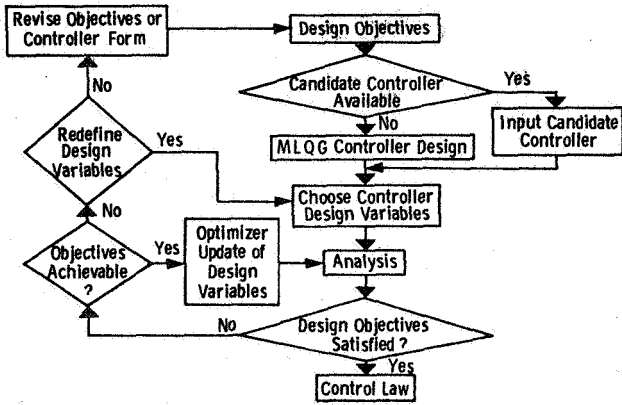

FIGURE 7. Block Diagram of Numerical Optimization Method

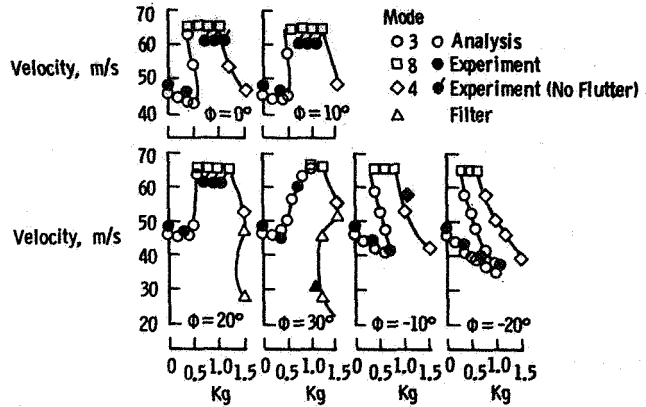

FIGURE 11. Measured and Predicted Stability Boundaries as a Function of Gain and Phase

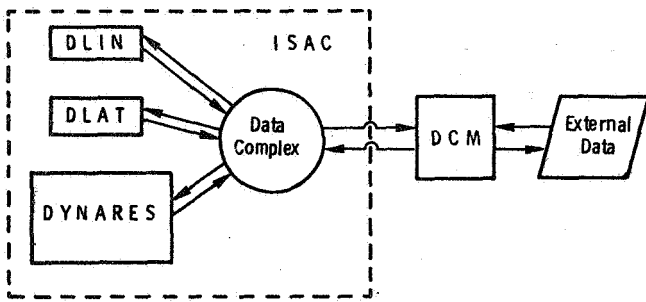

FIGURE 8. Flow Chart of ISAC Analysis Tool

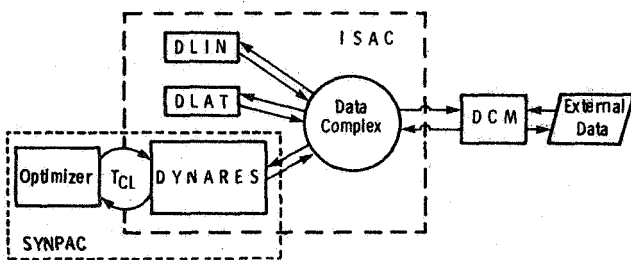

FIGURE 9. Flow Chart of SYN PAC Design Tool

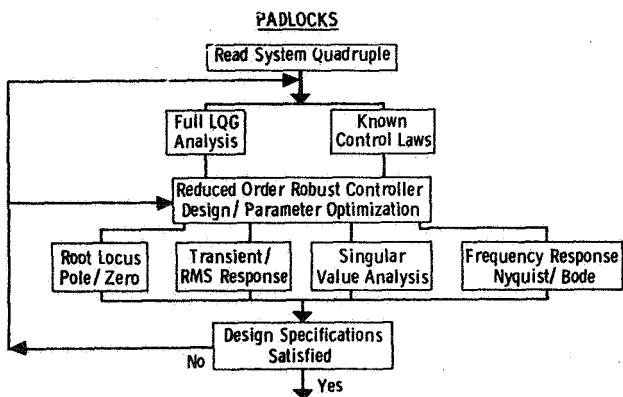

FIGURE 10. Flow Chart for PADLOCKS Synthesis Tool

Gust Loads on Active Control Wind-Tunnel Model

	Analysis	Experiment
$\phi = 0^\circ$	○	●
$\phi = 20^\circ$	□	■

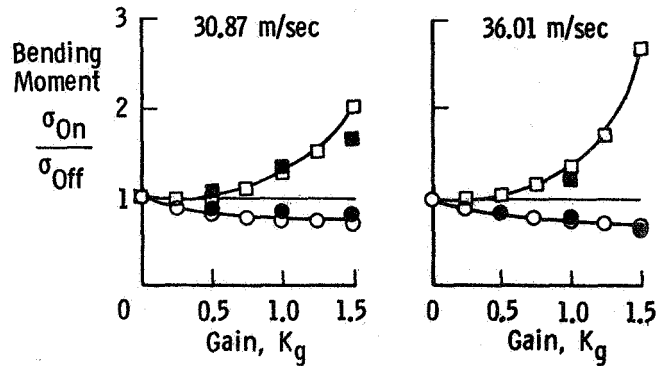

FIGURE 12. Measured and Predicted Gust Loads as a Function of Gain and Phase

DAST ARW-1 Flutter Suppression System

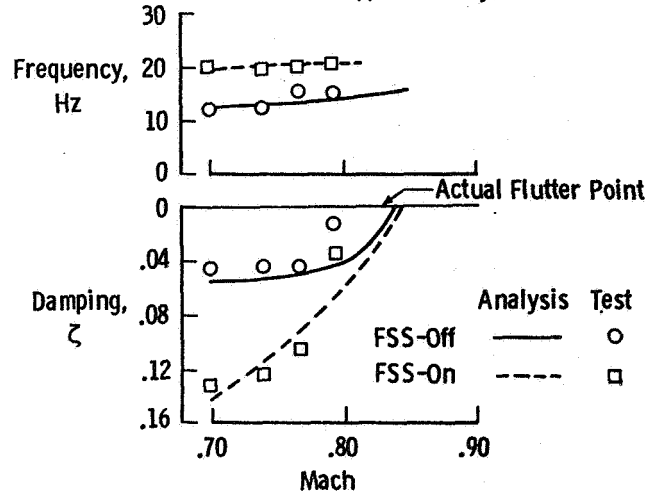

FIGURE 13. Comparison of Flight Test and Analytical Data

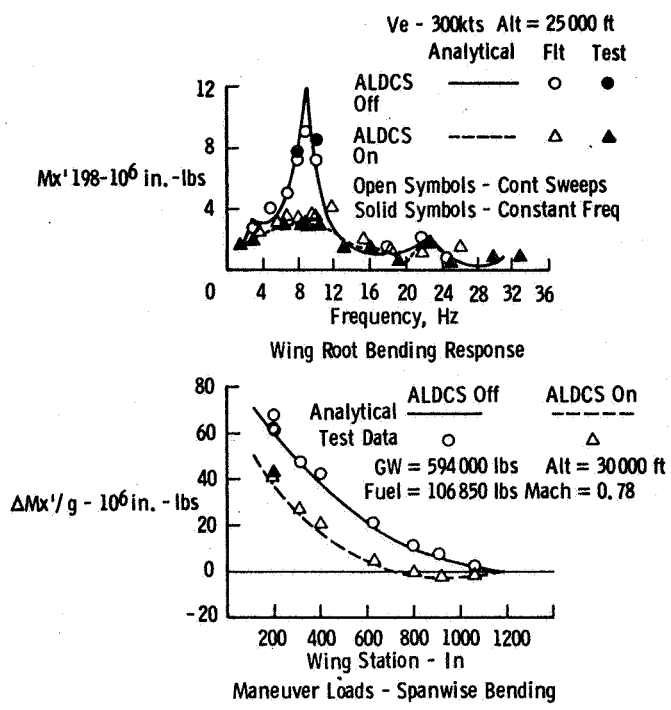

FIGURE 14. Comparison of Flight Test and Analytical Data for C-5A Active Load Distribution Control System (from ref. 15)

1. Report No. NASA TM-86269		2. Government Accession No.		3. Recipient's Catalog No.	
4. Title and Subtitle ACTIVE CONTROLS: A LOOK AT ANALYTICAL METHODS AND ASSOCIATED TOOLS				5. Report Date July 1984	
				6. Performing Organization Code 505-33-43-13	
7. Author(s) J. R. Newsom, W. M. Adams, Jr., V. Mukhopadhyay, S. H. Tiffany, and I. Abel				8. Performing Organization Report No.	
9. Performing Organization Name and Address NASA Langley Research Center Hampton, VA 23665				10. Work Unit No.	
				11. Contract or Grant No.	
12. Sponsoring Agency Name and Address National Aeronautics and Space Administration Washington, DC 20546				13. Type of Report and Period Covered Technical Memorandum	
				14. Sponsoring Agency Code	
15. Supplementary Notes To be presented at the 14th Congress of the International Council of the Aeronautical Sciences, Toulouse, France, September 10-14, 1984.					
16. Abstract A review of analytical methods and associated tools for active controls analysis and design problems is presented. Approaches employed to develop mathematical models suitable for control system analysis and/or design are discussed. Significant efforts have been expended to develop tools to generate the models from the standpoint of control system designers' needs and develop the tools necessary to analyze and design active control systems. Representative examples of these tools are discussed. Examples where results from the methods and tools have been compared with experimental data are also presented. Finally, a perspective on future trends in analysis and design methods is presented.					
17. Key Words (Suggested by Author(s)) active controls aeroservoelasticity optimization			18. Distribution Statement Unclassified-Unlimited Subject Category 39		
19. Security Classif. (of this report) Unclassified		20. Security Classif. (of this page) Unclassified		21. No. of Pages 14	22. Price A02