

N 84 - 3 1 7 8 2

NASA Technical Memorandum 83684

Photovoltaics – The Endless Spring

Henry W. Brandhorst, Jr.
Lewis Research Center
Cleveland, Ohio

Prepared for the
Seventeenth Photovoltaic Specialists Conference
sponsored by the Institute of Electrical and Electronic Engineers
Kissimmee, Florida, May 1-4, 1984

NASA

PHOTOVOLTAICS - THE ENDLESS SPRING

Henry W. Brandhorst, Jr.
National Aeronautics and Space Administration
Lewis Research Center
Cleveland, Ohio 44135

E-2121

As I prepared for this address, I was struck by the coincidence of dates that are important to the photovoltaic community. First 1954, a short 30 years ago, that saw the birth of the modern silicon solar cell fathered by Gerald Pearson and co-workers. Of course, if Paul Rappaport hadn't been so anxious to shut out the light that was causing a pesky background signal in his silicon diodes, we would have celebrated the thirtieth anniversary a year or two earlier. Paul certainly recognized the benefit of light and diodes shortly thereafter and made prodigious contributions to photovoltaics as we all know. Paul and his peers, Joe Loferski and Martin Wolf, laid the foundations of the field that allow the rest of us to make our contributions. Clearly we all stand on the shoulders of giants.

The second date that we have just celebrated is the tenth anniversary of the Cherry Hill conference that gave birth to the decade-long terrestrial photovoltaic program that we have been enjoying. Among the parents of this child we find John Goldsmith, Dick Bleiden and, of course, Bill Cherry. This tenth anniversary of Cherry Hill will be highlighted by a special Wednesday evening session at this Seventeenth Photovoltaic Specialists Conference. I will also make a few comments shortly about that critically important meeting.

The third coincidence is less happy for it was just five short years ago that we lost the warmth, insight and guidance of William R. Cherry. Bill gave the silicon cell its push into space and the rest of us continual caring challenge and inspiration. From outer space, through "Cherry-pie-in-the-sky" tethered balloons to full terrestrial utilization, Bill was the proverbial man for all seasons. The seeds he planted continue to flourish. Let's take a look where we stand.

The last 3 years have been a time of strengthening the field. Government support was reduced, but through the "magic of the marketplace", industry responded, has come through a shakeout and has emerged stronger and more vital. The third leg of the triad -- the university community -- has seemed to suffer the most with reduction in funding and loss of student base. It is important that we recognize the desirability of maintaining this triad, for each link has its separate, vital role as shown in figure 1. This being an Olympic year, I thought about adding a few more rings, but decided against it and will let the "PVSC run" cover that aspect. In a somewhat oversimplified form, I've identified contributions made by these three sectors. The best role of the university is to provide both the well trained individuals to all sectors and also the systematic research that provides the foundation of the field. The role of government is to provide goals and program management, and to support high risk R&D. Industry provides process development, production and marketing that makes the field flourish. Analogous to nature, the universities are the rich soil, the government, the seeds, and industry the water and harvester. It is essential that all parts work well together to maximize the yield.

Which brings me to Cherry Hill. Cherry Hill brought together about 125 people from university, industry and government, including utility representatives. In this workshop, goals and funding for a decade-long enterprise were established. This widely participative process ensured a strong foundation for this program. Specific goals, to be achieved by 1985, are shown in figure 2. At the time, these production volumes seemed astounding, but we've done pretty well historically as shown in figure 3. While the major reductions in government support over the past few years have caused significant concern, a comparison to the funding requested by the Cherry Hill participants (fig. 4) shows that we have done pretty well. In fact, we've received about 50 percent more funding overall than was requested! How have these funds succeeded in meeting the cost goals? If we look at the goal set for single crystal silicon cell -- 50¢/peak W -- we have a hard time separating the cell cost and inflation impact from the present day module price of roughly \$7.50/Wp. Therefore, with fear and trembling, I resorted to the learning curve approach using Consumer Price Index figures for inflation and data on worldwide volume from Strategies Unlimited. The data shown in figure 5 indicate a curve typical of transistors and indicates we're now moving along about a 67 percent curve. I've noted projections made by Paul Maycock that suggest an alarming air of consistency. If we extrapolate this curve -- an exceptionally dangerous practice -- to the 500 MW level envisioned by those at Cherry Hill, we get a module cost of about \$1.25/peak W which makes a 50¢/peak W cell fit right in. I'd say we've been doing exceptionally well in meeting the goals set a decade ago! The funding reductions of the past years have been troubling to all, but I've found that such cuts can actually be healthy and can well serve to strengthen rather than harm. The end result is determined pretty much by the philosophy used to trim back so I'd like to spend a bit of time talking about philosophy.

Last conference, Martin Wolf noted that a component such as a cell is of no significance without a system and a system has no impact without applications. Furthermore, he noted that the capabilities of the system can depend critically upon the performance of components. Because the photovoltaic effect is so widespread and exciting, we often get sidetracked by the device alone and fail to look at all of the implications. There are three attributes that naturally come to mind when we talk of photovoltaic devices: cost, efficiency and stability. Figure 6 pulls these factors out into their separate crystal balls and identifies some of the photovoltaic performers that are playing to each of these audiences. For the most part, however, it seems that those researchers working on concentrator systems or on space cells gravitate toward high efficiency, stable devices, while the cost-minded terrestrial researcher examines those devices in the low cost category although stability is also of interest. With only these three factors, it's hard to decide where to trim a program, for all have their advocates and attributes.

Only by moving to the systems level can we help resolve the dilemma for there the massive balance-of-system (BOS) cost comes into play. The dominant role of BOS costs has been known for over a decade. Spakowski and Shure showed in 1972 that costs of mounting modules on posts and frames cost about \$100/m². Interestingly, they also suggested that a network of poles and taut cables may do the job for less than \$2/m². Over the years, EPRI, Martin Wolf, and researchers at Sandia Laboratories have clearly shown the incontrovertible interlacing of BOS costs, panel costs and device efficiency. Figure 7 shows some of the latest data from Sandia which disclose that module costs of 50¢/W and efficiencies of 25 percent are required to produce power for 15¢/kWhr -- provided

area related BOS costs are only \$50/m²! To put BOS costs into perspective, a 25 percent efficient module costing 50¢/W has an area related cost of \$125/m². The challenge is exceptionally clear.

Which brings us back to our strategic philosophy of research. It is clear that cost, efficiency and stability are all interrelated as shown in figure 8. The challenge is to achieve all three simultaneously. This serves to severely limit options. It has been my experience over the years that first you make a device efficient, then stable (if necessary), then low cost. To work in the opposite order simply makes no sense. Low cost devices cannot be made high performance, but high performance devices can be made low cost. After all, that's just what the JPL program has been doing. Another small example: We were used to making rather sophisticated, high performance (13.5 percent AMO, 16 percent AM1.5) cells for space use, using complex manual processing. In a bold move, we made a first attempt to go to all nonvacuum processing -- surface texturing, screen printed BSF and contacts and spin-on antireflection coatings. Cell efficiency dropped to about 11.5 percent AMO, but costs dropped a factor of 25 to 50. Furthermore, the screen printed BSF was shown to be clearly superior to other approaches and is now standard.

Let me illustrate the approach another way. Figure 9 displays my philosophy rather clearly. Performance (efficiency) is the driving force for the entire process. Stability is the foundation that keeps us moving ahead, while costs are reduced as we move ahead. If someone at this conference were to announce a 35 percent efficient, stable device, I think it's safe to assume there would be a concerted corporate and government rush to reduce its cost to an acceptable level.

If we come at the problem the opposite way -- with low cost being the first selection criteria -- then my view of what happens is shown in figure 10. You just can't get to your goal from there. Low cost, low efficiency panels have an appropriate market share, but it's not bulk power production. A few words on stability that should be obvious. If you're able to form a device at low temperatures, it's likely that it will degrade at low temperatures -- chemistry and all that being the same the world around! Furthermore, materials compatibility must be foremost -- everyone is fully familiar with problems of contact metallurgy. The highest priority must be devoted to ensure stability at the basic device level. That is the final line of defense against the environment. Chemical reactions between atmospheric gases, encapsulants, voltages, metallization and coatings must all be carefully balanced to ensure durability.

I would like to see a closer union between the space and terrestrial technologies. For the terrestrial community to dismiss developments in the space program in a knee jerk fashion as "too expensive" is risky and shortsighted. For example, the space program devoted great effort to developing interconnects that would withstand thousands of deep thermal cycles per year (+80° to -80° C). Unfortunately, some of the earliest terrestrial modules failed after only a few hundred cycles under much more benign temperature cycles. Fortunately, these troubles seem to be passing away. Conversely, the space program must also take advantage of the tremendous advances in the terrestrial field, especially in the area of high performance devices and high voltage, high power systems.

What does all this suggest to me as appropriate directions for the field? First and foremost, I believe major, if not exclusive, effort should be devoted to those materials which have demonstrated high efficiency potential. These would be primarily the III-V materials as shown in figure 11. These materials systems are so richly versatile that we have barely begun to uncover this "mother lode." The versatility of ternary and quaternary combinations seems to offer endless potential. For example, were you to seek to make a single junction cell with a 1.55 eV band gap -- a cell approximately at the peak of the efficiency-band gap curve at a modest operating temperature -- you might discover about a dozen suitable combinations. These combinations all have appropriate lattice constants and materials properties that could lead to efficiencies above 24 percent AMO (28 percent AM 1.5). Furthermore, these materials systems are also the choice of those seeking to break the 30 percent barrier with the multiple junction cascade cell. An example of the performance potential of this area is demonstrated by the 1.15 eV band gap bottom cell in a three-junction cascade cell being developed at Varian Associates. This device, with a band gap much like silicon, achieved a 17.6 percent AMO at 100X right off the bat!

For the space community, which is bringing GaAs into its own as a viable commercial product, the III-Vs offer additional benefit beside high performance. There are materials systems such as InP that appear to have substantially greater radiation resistance than GaAs. The radiation resistance characteristics of this "new frontier" have scarcely been touched. My deepest concern is over the lack of funding being devoted to this entire area; we are dangerously near subcritical.

I am aware that many of you are seriously and rightly concerned about cost of these materials. In their present form these devices are much too expensive, but there are two saving graces that have not been fully explored and developed. First, because these materials all largely have direct band gaps, only several micrometer thick layers are needed for total light absorption. Innovative substrates and deposition techniques for forming suitable, high quality layers must be developed.

The second approach is to use sunlight concentration to reduce cell area, hence cell costs. I believe it is imperative to take advantage of the miniature concentrators such as shown in figure 12. This conceptual 100X concentrator panel is only a half-inch thick, has high strength and, best of all, operates at a temperature of about 85° C in space and only 25° C on earth with no additional cooling. The key is the miniature size, which was pioneered by RCA, furthered by Lockheed and now TRW. Also of critical importance is the technological transparency (fig. 12) of the miniature concentrator. Higher performance cells such as cascade structures would directly replace the 5x5 mm GaAs cells intended for its first use. I especially like the space potential of an erectable array for space use shown in figure 13. My thanks to the TRW artist who conceptualized most of this design for a space station. Once more, this creative approach offers higher performance and lower cost than a competitive flat plate array. Additionally, the III-V area opens the door to superlattice structures. The intriguing thing about superlattices is their apparent ability to decouple parameters such as mobility and lifetime. That, plus the multitude of possible superlattices -- constitutional, doping, etc., -- seems to offer amazing potential for the future.

Continuing with the idea of compositional variations leads us to another concept. About a decade ago we began a systematic quest to achieve the maximum theoretical open circuit voltage in the silicon solar cell. The goal of 680 mV set in 1972 has recently been achieved by the outstanding work of Martin Green. Let us challenge what lies beyond and challenge some of the basic factors which control cell voltage. My co-worker, Victor Weizer, has devised procedures to separate the base and emitter saturation currents and has used them to uncover additional approaches that can be used to further enhance cell voltage. By careful changes in cell composition affecting mobility, it may be possible to achieve voltages above 750 mV. This offers silicon efficiencies beyond 20 percent AMO.

Additives to silicon are useful in yet another way. The addition of n-type lithium to p-type base cells has substantially increased their radiation tolerance over similar cells containing no lithium. Irv Weinberg has shown this benefit results from lithium combining with harmful oxygen impurities. Once again a fruitful path has been identified which surmounts a barrier. The possibility of radiation tolerant, ultrathin, 20+ percent efficient silicon cells has tremendous potential for space use. By daring to challenge the unquestioned and by doing the unconventional, these workers and many others in the audience are moving the entire field forward.

This really brings me down to my final points. In my view, the potential of photovoltaics is limitless. I previously showed the terrestrial marketplace, now figure 14 shows projections of energy usage in space. There is an awakening of the space community to the need for great quantities of energy in space so I expect this driving force to continue. Shortly you'll hear from Moe Forestieri about the anticipated space station. They expect a 75 kW bus which means a 200 kW array. While small by terrestrial standards, this station alone will double the amount of power launched by NASA since the beginning of the agency.

Technically, I see a limitless spring having incredible diversity. The III-Vs offer decades-long potential and future work, including wave approaches, will certainly serve to occupy us well into the next century.

The terrestrial industry, though tested, seems equal to the challenge and is emerging stronger than before. Government funding for research though much reduced is adequate. I see a commonality of eventual goals between space and terrestrial applications -- both will require high efficiency, exceptional stability and low cost at a device as well as array level. That is the difficult challenge, but the prize is worth the effort. BOS costs must also continue to decrease.

Finally, it is important to recognize that it is the relationships we build with one another as a community that will determine the rate of progress we can make. In fact, I suspect that the relationships we build among ourselves are more important than the technical accomplishments we make. All of us have parts of the puzzle; each can, and must, benefit from the insight of those around them. Be open, be positive, be caring and build lasting relationships.

Now a final challenge: Each of you here must decide whether you want to be a trunk clutcher; living a safe but drab existence, running no risk that

your peers will deride you for your work and your ambitions. Or you can chose a life of adventure as a limb sitter. The key here is to be willing to take on challenges unlike those to which you've become accustomed. The good life is adventure, but more than that, it is purposeful adventure -- goal directed and visionary. By choosing adventure, we can ensure that photovoltaics will indeed be the endless spring.

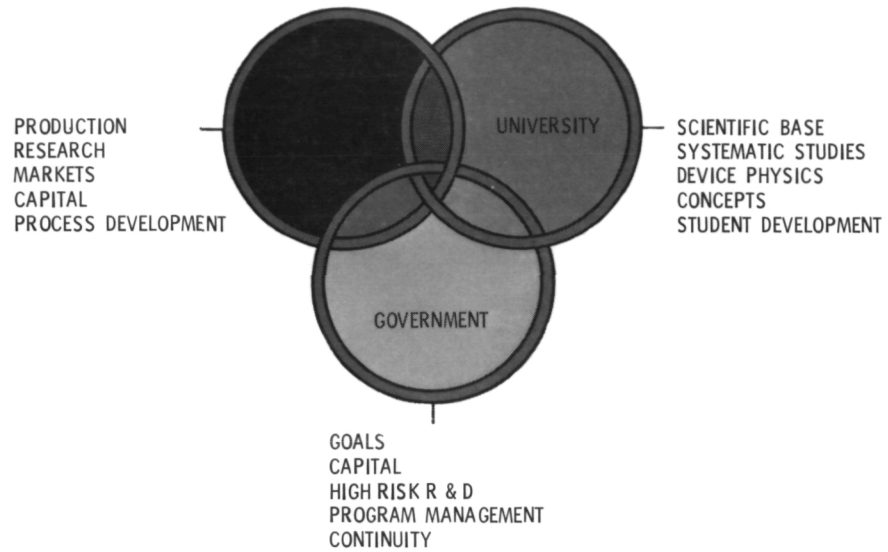

Figure 1. - Interlocking responsibilities of three sectors.

- SILICON - \$0.50/Wp CELL, 500 MW/yr, COST - \$250M
- $\text{Cu}_2\text{S/CdS}$ - \$0.20/Wp CELL, 1,000 MW/yr, COST - \$183M
- POLYCRYSTALLINE Si - \$0.50/Wp, 10 MW/yr, COST \$45M
- OTHER MATERIALS & DEVICES - IDENTIFY ONE NEW SYSTEM (5 yr), COST \$14M
- INSULATION TESTING & EVALUATION - EVAL/ACCEL. TESTING LAB (5 yr), COST \$9M
- SYSTEMS - 100 KW SYSTEM (5 yr), COST \$15M

Figure 2. - Cherry Hill conference, projections for 1985.

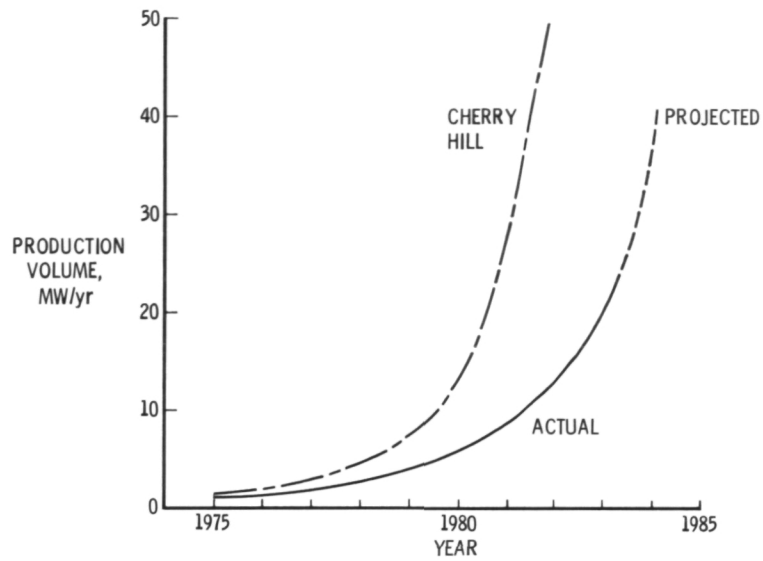

Figure 3. - Photovoltaic module production.

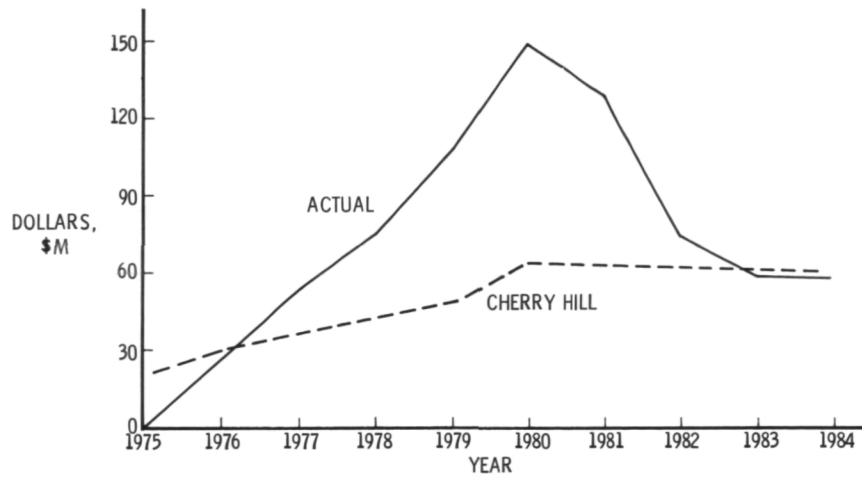

Figure 4. - Funding of DOE terrestrial photovoltaic program.

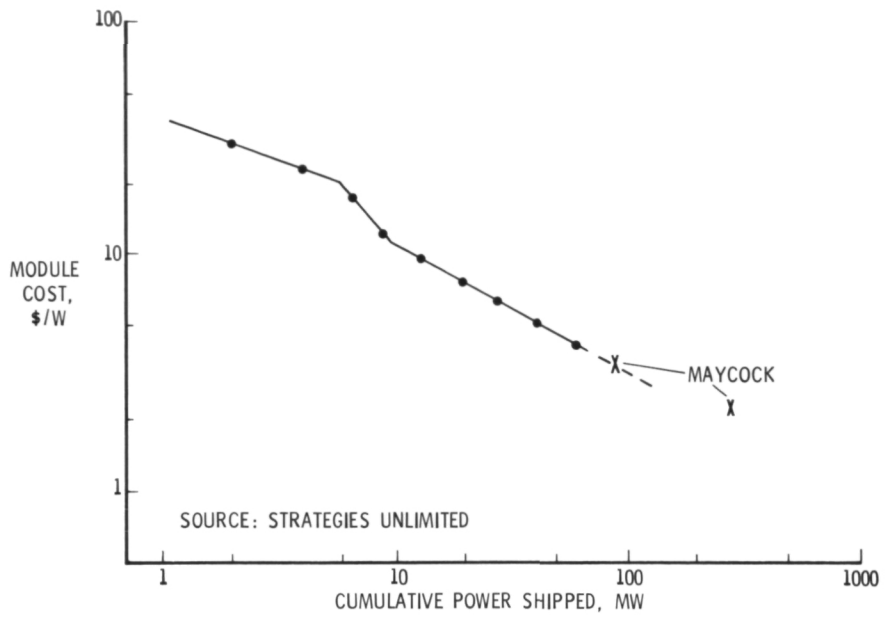

Figure 5. - Worldwide photovoltaic module experience 1975-1983.

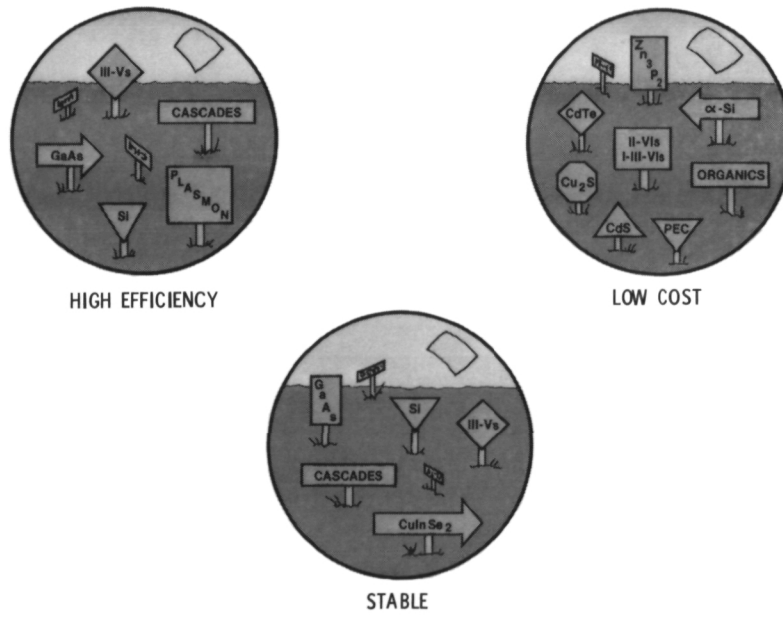

Figure 6. - Photovoltaic device attributes.

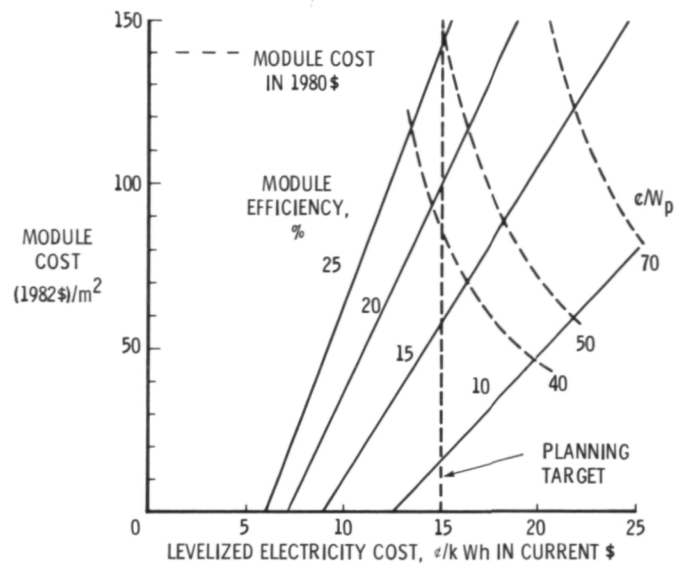

Figure 7. - Module costs and efficiencies vs 30-year levelized electricity costs for flat plate photovoltaic systems.

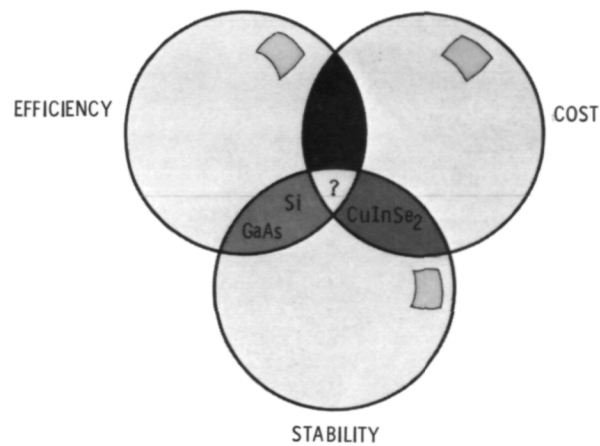

Figure 8. - The challenge for photovoltaics.

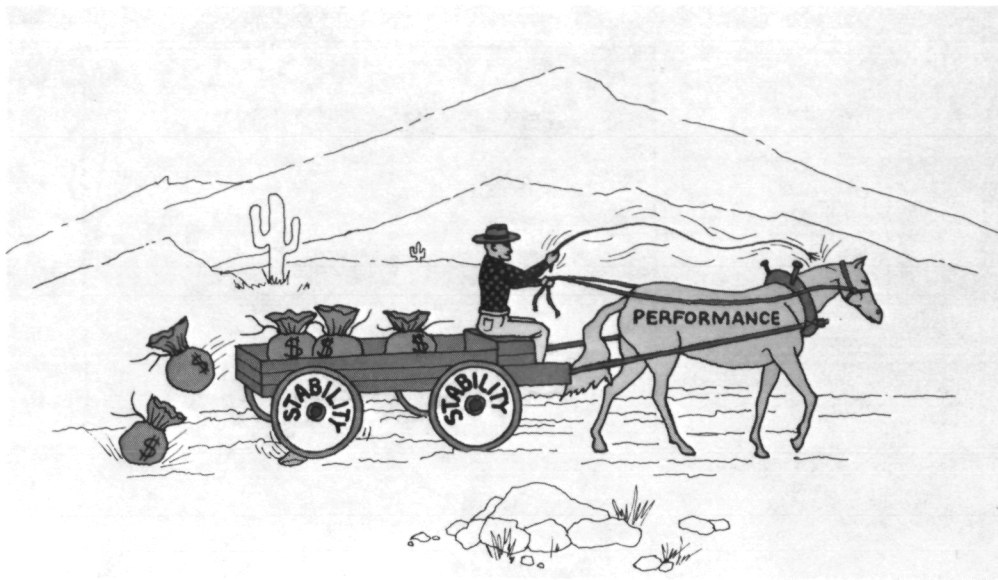

Figure 9. - Desirable strategy to achieve ultimate goal.

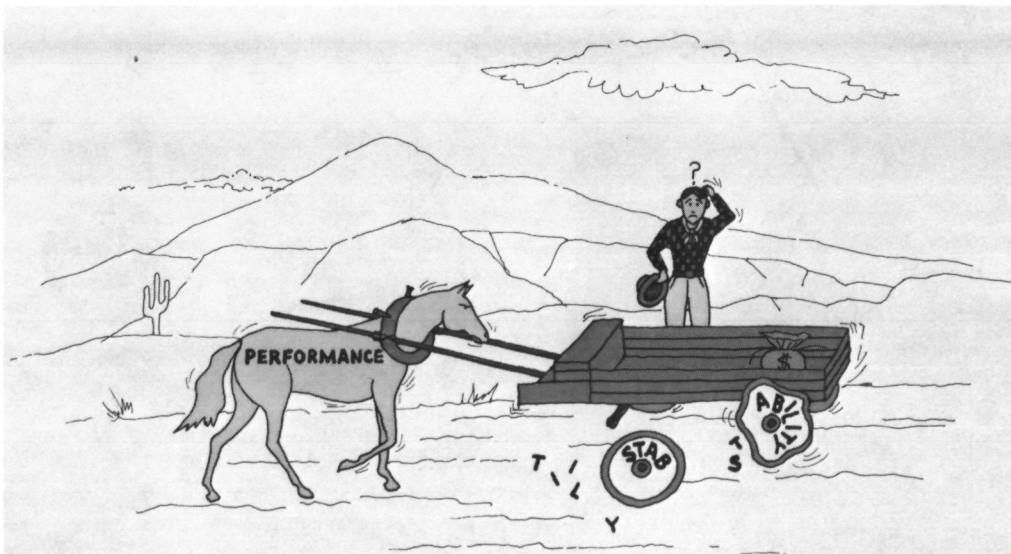

Figure 10. - Hard way to reach goal.

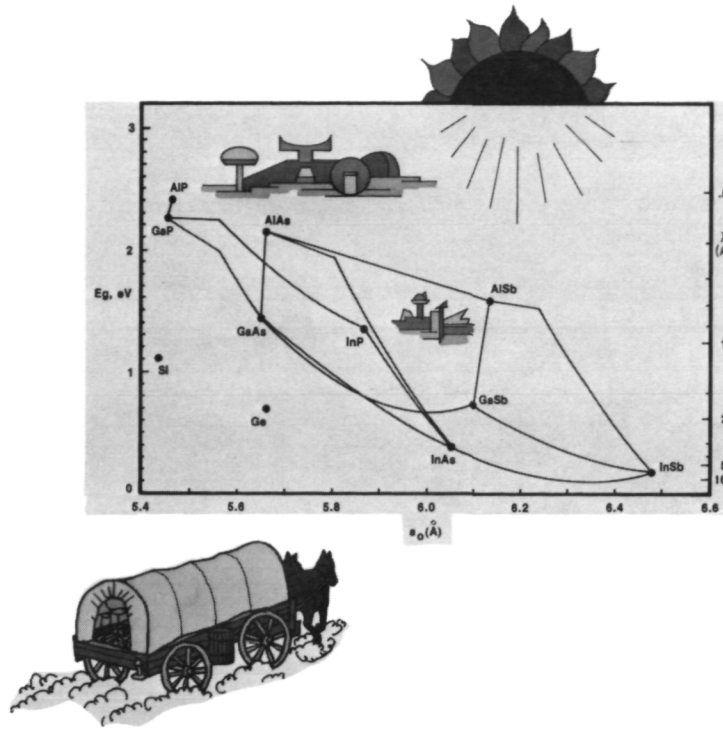
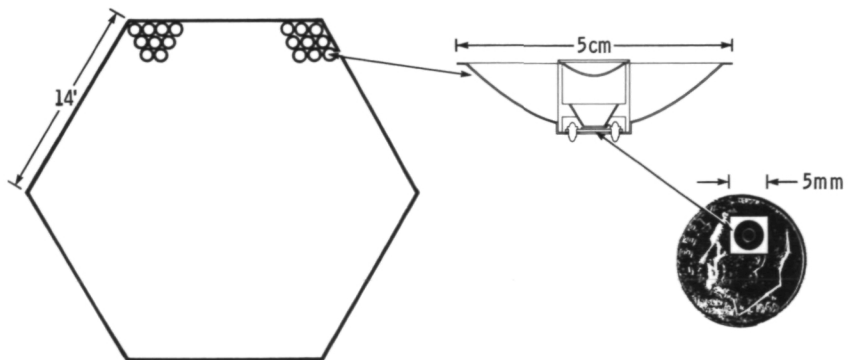

Figure 11. - New opportunities.



- TECHNOLOGY TRANSPARENT
- RIGID YET THIN
- VERSATILE SHAPE
- 85° C SPACE, 25° C TERRESTRIAL
- 125x

Figure 12. - Miniature Cassegrainian Concentrator (mc²).

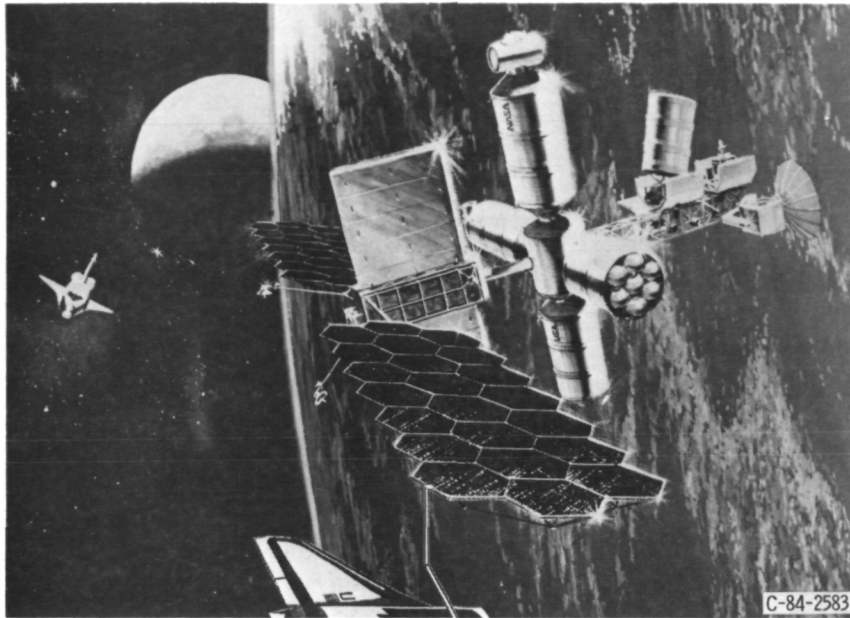

Figure 13. - A new way of doing business.

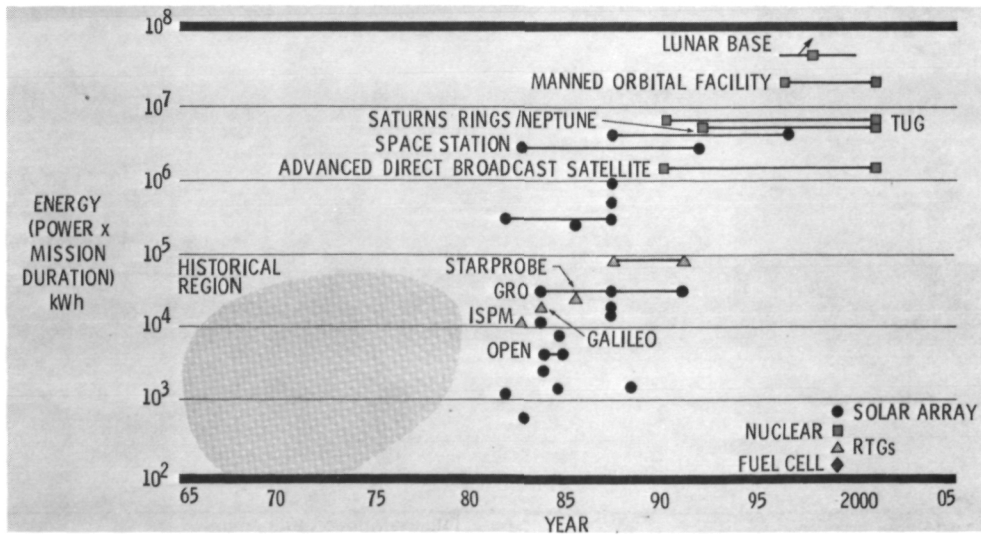

Figure 14. - Future space energy demands.

1. Report No. NASA TM-83684		2. Government Accession No.		3. Recipient's Catalog No.	
4. Title and Subtitle Photovoltaics - The Endless Spring				5. Report Date	
				6. Performing Organization Code 505-55-42	
7. Author(s) Henry W. Brandhorst, Jr.				8. Performing Organization Report No. E-2121	
				10. Work Unit No.	
9. Performing Organization Name and Address National Aeronautics and Space Administration Lewis Research Center Cleveland, Ohio 44135				11. Contract or Grant No.	
				13. Type of Report and Period Covered Technical Memorandum	
12. Sponsoring Agency Name and Address National Aeronautics and Space Administration Washington, D.C. 20546				14. Sponsoring Agency Code	
15. Supplementary Notes Prepared for the Seventeenth Photovoltaic Specialists Conference sponsored by the Institute of Electrical and Electronic Engineers, Kissimmee, Florida, May 1-4, 1984.					
16. Abstract This paper presents a perspective of developments in the photovoltaic field over the past decade or two. A review of accomplishments in the terrestrial field is presented along with projections and challenges toward meeting cost goals. The contrasts and commonality of space and terrestrial photovoltaics is presented. Finally, the paper presents a strategic philosophy of photovoltaics research - highlighting critical factors, appropriate directions, emerging opportunities and challenges of the future.					
17. Key Words (Suggested by Author(s)) Photovoltaics			18. Distribution Statement Unclassified - unlimited STAR Category 44		
19. Security Classif. (of this report) Unclassified		20. Security Classif. (of this page) Unclassified		21. No. of pages	22. Price*

National Aeronautics and
Space Administration

Washington, D.C.
20546

Official Business

Penalty for Private Use, \$300

SPECIAL FOURTH CLASS MAIL
BOOK



Postage and Fees Paid
National Aeronautics and
Space Administration
NASA-451

NASA

POSTMASTER: If Undeliverable (Section 15M
Postal Manual) Do Not Return
