

NASA Technical Memorandum 85802

NASA-TM-85802 19840024756

Aircraft Landing Dynamics Facility Carriage Weld Test Program

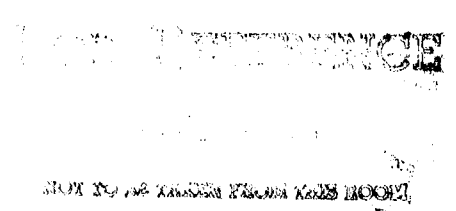

Ashby G. Lawson

SEPTEMBER 1984

LIBRARY COPY

SEP 23 1984

LANGLEY RESEARCH CENTER
LIBRARY, NASA
HAMPTON, VIRGINIA



National Aeronautics and
Space Administration

Langley Research Center
Hampton, Virginia 23665

TABLE OF CONTENTS

1.0 Introduction.....1

2.0 Objectives.....1

3.0 Test Program.....1

4.0 Base Material Certification.....2

 4.1 Chemical Composition.....2

 4.2 Mechanical Properties.....2

 4.3 Ultrasonic Tests.....3

5.0 Weld Metal Certification.....3

6.0 Welding Characteristics.....3

7.0 Connection 836.....5

 7.1 Fabrication Procedure.....5

 7.2 NDE.....6

 7.2.1 Magnetic Particle Examination.....6

 7.3 Destructive Testing.....6

 7.3.1 Tension Testing.....6

 7.3.2 Macrosection Examination.....6

8.0 Connection 314.....7

 8.1 Fabrication Procedure.....7

 8.2 NDE.....7

 8.2.1 Magnetic Particle Examination.....7

 8.2.2 Radiographic Examination.....8

 8.3 Mechanical Test.....8

 8.3.1 Instrumentation.....8

 8.3.2 Testing Equipment.....8

 8.3.3 Tension Test.....8

 8.3.4 Compression Test.....9

9.0 Conclusions.....10

10.0 Acknowledgements.....12

11.0 Reference.....12

12.0 Table and Figures.....13

N84-32827 #

1.0 Introduction

The carriage weld test program was initiated to investigate concerns relative to construction of the high speed main carriage which is to be used at the Aircraft Landing Dynamics Facility (Figure 1). The carriage will be constructed of high strength, quenched and tempered steel, welded under the requirements of the AWS Structural Welding Code D1.1. The design is based on material yield strength of 100,000 psi.

2.0 Objectives

The objectives of the program were to establish the welding characteristics of the materials specified for the carriage and to determine the degree of difficulty associated with obtaining sound, crack-free structural joints and ascertain the joint's structural integrity. A parallel objective was to gain "hands-on" experience in welding high strength, quenched and tempered steel. The experience gained was to be reflected in the carriage fabrication specification and later in the on-site inspection.

3.0 Test Program

The test program involved: procuring designated carriage materials and consumables (welding electrodes); certification of their chemical and mechanical properties; determining the welding characteristics of the materials; and construction and testing of two typical carriage joints. The specific materials used for the tests were low alloy quenched and tempered tubing and E11018M welding electrodes. The hemispheres for the spherical joint were fabricated from ASTM A514 Grade B material.

4.0 Base Material Certification

4.1 Chemical Compositon

A Diano Corporation X-ray emission spectrometer coupled to a PDP 8 digital computer was used for the test. Tests were performed to ASTM Stadard A322, "Method for X-ray Emission Spectrometric Analysis of Low Alloy Steels." The test results are summarized in Table 1. Chromium was found to be in excess of the specified range in the 3 1/4" and 4 1/4" diameter tubes. The highest level, 1.35 percent in the 4 1/4" diameter tube, was not considered to have a significant effect on the weld properties since the tubing manufacturer recommended welding electrode (E12018M) can have a .30 to 1.50 percent chromium. Hemispheres were found to be within the chemical composition limits for ASTM A514 Grade B. The most significant finding was that the tubing manufacturer's certificate of test was not consistent with the actual composition.

4.2 Mechanical Properties

Tensile tests were performed using a 55,000 lbs. MTS testing machine. Strain gages were attached to each specimen and load vs. strain was recorded on a Packard X-Y recorder. ASTM Standard A370, "Mechanical Testing of Steel Products," test procedures were used. Mechanical properties of the hemispheres were not established because there was insufficient material. The test results are summarized in Table 2. Although all material had the minimum required strength, there was significant difference between the manufacturer's certificate of test and the actual measured strengths.

4.3 Ultrasonic Tests

All hemispheres and tubes were tested for internal defects, using a longitudinal straight wave and shear wave ultrasonic testing procedure to MIL STD 271E. No defects were indicated. Visual examination of the tubes located several blisters on the inside surface of a 6 inch diameter tube. Sections of the blistered area showed laminations to exist .030" from the surface (Figure 2). UT examination of the known blistered area again gave no indication of lamination.

5.0 Weld Metal Certification

Table 3 summarizes the results of the weld metal certification tests. Equipment and procedures used to establish chemical composition and mechanical properties were the same as described in Section 4.1 and 4.2. Two lots of E11018M and one lot of E12018M electrodes were evaluated. The specimens were produced by depositing sufficient weld metal to permit the machining of the all weld metal specimens with a reduced section of .505" diameter. The specimens for the unidentified lot of E11018M electrode was produced with a higher heat input than the E11018M Lot 11351A electrode specimens.

6.0 Welding Characteristics

Because the carriage construction consists of over 1500 welds, this section of the test program was of paramount importance to the program. Shielded metal arc welding was the process used and material manufacturer's recommendations were followed. All welding was performed in the simplest positions (flat or horizontal) to eliminate welder influence on weld

quality. Evaluation of weld procedures was by testing the mechanical strengths of the welds only. Bend specimens were not tested since published data indicated proper welding techniques will produce sound welds.

Listed below are three rules which, when followed, will produce welds with the desired properties:

1. Use correct electrode
2. Use correct welding technique
3. Use correct weld heat input

Rules 1 and 2 can be verified by observation. Rule 3 requires parameter measurements while welding is in progress. The material manufacturer lists maximum heat input for various metal thicknesses and preheat temperatures. Weld heat input is determined as follows:

$$\text{Weld heat input (joules per inch)} = \frac{\text{Amperes} \times \text{volts} \times 60}{\text{welding speed (inches per min.)}}$$

Listed in Table 4 are mechanical properties of welds produced with differing heat inputs. This demonstrates that as heat input is increased beyond the recommended range, yield strengths decrease while tensile strengths remain constant.

The correct welding procedure was established by addressing each rule as follows:

Rule 1. The electrode used was a Class E11018M which is a low hydrogen electrode with strengths of 98 KSI yield strength (s_y) and 110 KSI ultimate strength (S_u).

Rule 2. The technique was stringer bead welds with grinding weld start and stop locations.

Rule 3. The weld heat input was as per the material manufacturer recommendations.

Note on Rule 3: Consideration was given to identifying nondestructive test which would establish weld quality (mechanical properties) after the weld was completed. One method explored was the hardness test, which is directly related to ultimate strength. As can be seen from Table 4, which related heat input to mechanical properties, ultimate strength remained approximately constant while yield strengths varied considerably. Therefore, weld heat input must be monitored during welding to verify weld strength.

7.0 Connection 836

Connection 836 (see Figure 3) is representative of many carriage joints with included angles less than 30° . This connection is a double Y joint using one $4 \frac{1}{4}$ " OD x .375" wall tube and two $3 \frac{1}{4}$ " OD x .188" wall tubes at a 10° angle.

7.1 Fabrication Procedure

The $3 \frac{1}{4}$ " diameter tubes were machined to fit the $4 \frac{1}{4}$ " diameter tube at the 10° angle, and weld grooves were ground manually to the desired angle. Exact prewelding fit-up was easily achieved since unwelded ends were not at a fixed location. Tubes were welded using the SMAW process with E11018M electrodes. End attachments were installed on the $3 \frac{1}{4}$ " diameter tubes to allow for tension testing.

7.2 NDE

7.2.1 Magnetic Particle Examination

STD 271E with no cracks indicated. However, a 1/2" long crack, 1/2" away and parallel to the weld, was indicated. The crack was repaired as per AWS D1.1 requirements.

7.3 Destructive Testing

7.3.1 Tension Testing

A 1,200,000 lbs. Tinius Olsen testing machine was used to apply tension loads with a potentiometer connected to the cross heads of the machine to measure displacement. Also, the connection was painted with stress coat to indicate points of yielding. Sequential loading was as follows:

Run #1 0 to 99,000 lbs. (50% S_Y)

Run #2 0 to 141,000 lbs. (75% S_Y)

Run #3 0 to 188,000 lbs. (100% S_Y)

Run #4 0 to 203,000 lbs. (108% S_Y)

After each load cycle the stress coat was inspected for indications of yielding. At 100 percent of calculated S_Y both stress coat and the displacement potentiometer indicated yielding. For results of displacement vs. load see Figure 4. For results of stress coat at 100 percent S_Y see Figures 5, 6, and 7.

7.3.2 Macrosection Examination

Macrosections of the weld were evaluated to the following criteria (Figure 8):

1. Have no cracks.
2. Have thorough fusion between adjacent layers of weld metal and between weld metal and base metal.
3. Have weld details conforming to the intended details.
4. Have no undercut exceeding .01".

All welds were acceptable. See Figures 9, 10, 11, 12, and 13.

8.0 Connection 314

Connection 314 is typical of 75 connections which employ spheres to separate tubes which are converging to a single point. This connection involved 8 tubes welded to a sphere with one of the tubes extending through the sphere (Figure 14).

8.1 Fabrication Procedure

Hemispheres were purchased, formed and heat treated to the desired requirements. Two hemispheres were positioned and welded together to produce the sphere. Tube location points on the sphere were established and the sphere was bored for the penetration tube. All weld grooves were machined and tubes were positioned to the sphere for welding. Welding was by the SMAW process using E11018M electrodes. End attachments were installed in tubes 3 and 4 to allow for loading of the connection. Holes were drilled in these attachments for tension testing and the attachment ends were machined flat for the compression test.

8.2 NDE

8.2.1 Magnetic Particle Examination

All welds first pass and final pass were examined as per MIL STD 271E. No cracks were indicated.

8.2.2 Radiographic Examination

The full circumference of the weld joining the two hemispheres was examined to MIL STD 271E with no defects indicated.

8.3 Mechanical Test

8.3.1 Instrumentation

Strain gages were installed to indicate yielding as follows:

8 on each tubes

6 on sphere

Also the entire Connection 314 was painted with stress-coat to give indications of yielding in other areas.

8.3.2 Testing Equipment

Equipment used to apply the loads was a 1,200,000 lbs. Tinius Olsen test machine with outputs from the strain gages and loads applied recorded on a Bechman recording system.

8.3.3 Tension Test

See Figure 16.

Based on calculations for this joint, yielding in the sphere would occur at a load of 200,000 lbs. which is 33 percent above the design load for this joint.

The objective of the tension test was to subject the sphere to this calculated yield load to test the welds in the elastic range.

Run #1 0 to 100,000 lbs.

Run #2 0 to 150,000 lbs.

Run #3 0 to 175,000 lbs.

Run #4 0 to 203,000 lbs.

Results - see Figure 17. Data from the strain gages and visual examination of the stress coat indicated no yielding had occurred.

8.3.4 Compression Test

See Figure 18. The objective of this test was to determine the yield and failure load for the sphere in compression. Loads were applied as follows:

Run #6 0 to 150,000 lbs.

Run #7 0 to 200,000 lbs.

Run #8 0 to 353,000 lbs

Run #9 0 to 447,000 lbs.

Results - Stress strain data are presented in Figures 19 through 22. During testing, yield was thought to have occurred at 353,000 lbs. at strain gage #9 location. Later analysis of the data showed yield at .2%, offset was a 418,000 lbs. for strain gage #9 and 425,000 for strain gage #13. Failure occurred at 447,000 lbs. with mode of failure being punching shear through the sphere outside of #4 tube to sphere weld close to strain gage #9 location. See Fgiure 23 and 24. The calculated failure load for this joint was 300,000 lbs. assuming an elastic - perfectly plastic material with a yield strength of 100,000 psi. Since the measured failure load was 447,000 lbs., the load carrying capability of the sphere exceeds that which was assumed in the sphere design.

9.0 Conclusions

Base Material Certification

Differences in mechanical properties result from variations in the chemical composition or the thermal treatment to which the material was exposed. ASTM A519 standard specifications for seamless carbon and alloy steel mechanical tubing requires one product analysis per heat on either billet or tube. The tubing manufacturer's specifications require tests to be performed on each lot of material, with lot being defined as "same outside diameter and wall thickness produced from the same heat of steel and subject to the same finishing heat treatment." Also, the amount of sampling per lot is from one specimen for 15 pieces or less to 6 specimens for 300 pieces or more. Potential problems with the above schedules are the number of specimens taken per piece and no requirement for sampling when product manufacturing is shut down for extended periods. Perhaps these problems account for the differences between the vendors certification and NASA chemical and mechanical property tests. Materials used in the fabrication of the carriage should have an independent certification of chemical composition and mechanical properties.

Ultrasonic Testing

Although UT is a recognized method for detecting internal defects such as laminations, there are some situations where this method is not valid. When inspecting materials with laminations close to the near or far surfaces, the defects will probably not be detected. Although not detected by UT, visual examination may

detect this type of defect since the defect could cause an irregular surface. During carriage fabrication, tubes are welded to the surfaces of the spheres. Hence, ultrasonic testing should be utilized to assure material soundness of the spheres, realizing the limitations of UT near surfaces.

Weld Metal Certification

Since all the electrodes tested had the required chemical composition, the variations in mechanical properties must be attributable to thermal treatment. Thermal treatment is determined by such weld parameters as preheat, weld heat input and interpass temperature. Low heat values will produce a weld metal in the quenched state having high strength, whereas, high heat values will result in the weld metal being in the tempered or annealed state resulting in low strengths.

Welding Characteristics

Sound crack-free welds with base material mechanical properties can be produced by following the three basic rules. The quality assurance program should be designed to address each with methods to assure adherence to established procedures.

The AWS code invoked for carriage construction requires that welded specimens be tested to establish their ultimate strength when establishing a weld procedure. The code does not address yield strength which is the main design criteria for the carriage.

As can be seen from Table 4, yield strength may vary considerably, while tensile strengths were sufficient to pass

code requirements. Also, for a Welder Qualification test, the code allows test to be performed on any material recognized by the code (i.e. A36, A53, A106, etc.) with no requirements for a test to determine mechanical properties. Because weld properties are critical to carriage quality, these deficiencies should be addressed as additions to the code for the carriage construction.

Connection 836

Connection 836 is easily constructed with minimum distortion if exact preweld fit-up is maintained and proper weld procedures are utilized. Nondestructive examinations with definitive results are limited to visual examination and magnetic particle testing.

Connection 314

As in Connection 836, no particular problems were encountered in the construction of this connection. NDE processes used were the same as those used for connection 836 and, in addition, RT of the weld joining the hemispheres was employed and good results were obtained.

10.0 Acknowledgements

The author wishes to acknowledge the contributions of Mr. Benjamin T. Updike for the design of the test connections and Mr. James Johnson for fabricating the specimens and coordinating the tests reported.

11.0 Reference

AWS D1.1 - American Welding Society Structure Welding Code
Steel - 1982

BASE METAL CHEMICAL COMPOSITION

SPECIMEN IDENTIFICATION	% CONCENTRATION					
	NI	CR	MN	MO	C	S
2" Dia. Tube #1	.08	1.10	.95	.17	.17	.016
2" Dia. Tube #2	.08	1.10	.94	.17	.19	.018
Manufacturer's Certificate of Test	---	.95	.96	.19	.19	.017
3½" Dia. Tube #1	.10	<u>1.11</u>	.88	.16	.20	.010
3½" Dia. Tube #2	.10	<u>1.14</u>	.87	.16	.21	.009
Manufacturer's Certificate of Test	---	.97	.87	.18	.20	.010
4½" Dia. Tube	.10	1.35	1.02	.18	.21	.019
Manufacturer's Certificate of Test	---	1.09	1.03	.20	.20	.019
6" Dia. Tube	.07	1.07	.88	.19	.18	.007
6" Dia. Tube	.07	1.06	.88	.19	.18	.008
Manufacturer's Certificate of Test	---	.93	.88	.20	.20	.009
Manufacturer's Specification	.25	.75-1.10	.70-1.05	.15-.25	.15-.21	.025 Max
Hemispheres	.01	.57	.90	.18	.19	.022
ASTM A514 Gr. B Specifications	---	.40-.65	.70-1.0	.12-.25	.12-.27	.04 Max

TABLE 1

MECHANICAL PROPERTIES

SPECIMEN IDENTIFICATION	S _y KSI	S _u KSI	ELONG %
2" Dia. Tube #1	100.5	112.2	11.5
2" Dia. Tube #2	100.2	112.1	11.5
Manufacturer's Certificate of Test	105.3	120.3	15.0
3¼" Dia. Tube #1	102.8	124.9	14.8
3¼" Dia. Tube #2	104.3	126.6	15.5
Manufacturer's Certificate of Test	120.9	132.3	15.0
4½" Dia. Tube #1	112.4	122.4	20.5
Manufacturer's Certificate of Test	104.4	.22.7	22.0
6" Dia. Tube #1	105.7	127.9	16.5
6" Dia. Tube #2	107.5	129.6	16.3
Manufacturer's Certificate of Test	125.0	135.3	15.0

NOTE: All test results are an average of three specimens except Manufacturer's Certificate of Test.

TABLE 2

WELD METAL QUALIFICATION

CHEMICAL ANALYSIS

ELECTRODE I.D.	COMPOSITION %					
	NI	CR	MN	MO	C	S
E11018M No I.D.	1.62	.25	1.55	.30	.06	.015
E11018M Lot No. 11351A	1.96	.01	1.69	.41	.05	.012
AWS Requirements	1.25-2.50	.40	1.3-1.8	.25-.5	.10	.03
E12018M	1.81	1.03	1.64	.33	.07	.018
AWS Requirements	1.75-2.50	.30-1.50	1.30-2.25	.3-.55	.10	.03

NOTE: Single values are maximum for AWS requirements.

MECHANICAL PROPERTIES

ELECTRODE I.D.			
	S _y KSI	S _u KSI	ELONG % (2")
E11018M No I.D.	83.6	100.8	25
E11018M Lot No. 11351A	120.5*	124.5*	20*
AWS Requirements	98.0	110.0	15
E12018M	102.1	113.8	25
AWS Requirements	107.0	120.0	14

*Indicates average of 2 specimens, all others are single specimen values.

TABLE 3

WELD JOINT MECHANICAL PROPERTIES PER HEAT INPUT

HEAT INPUT ABOVE SUGGESTED RANGE	S _u (KSI)	S _y (KSI)
500%	80.7	120.2
300%	87.7	117.2
16%	89.2	118.2
Suggested Range	99.7	121.6

- NOTE: 1. Strain gates used to determine yield strength.
 2. All values are an average of 3 test specimens.

TABLE 4

TOP

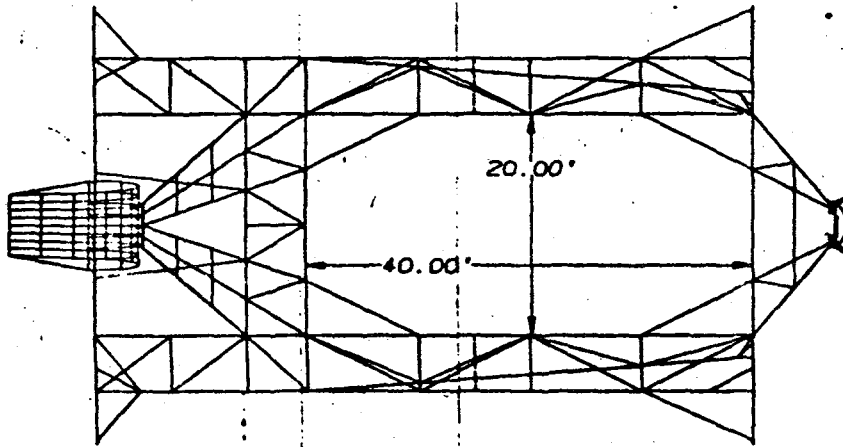

ISOMETRIC

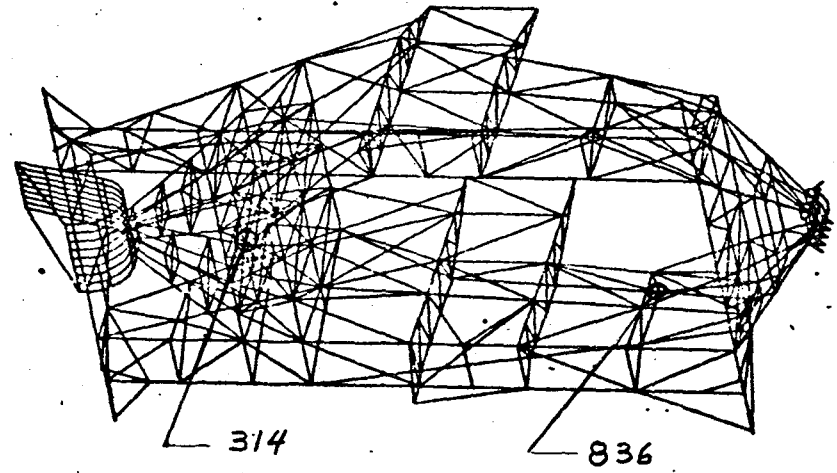

SIDE

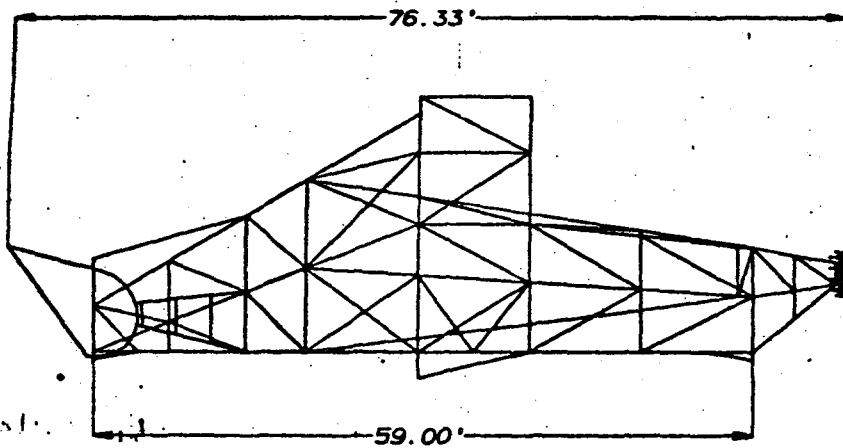

FRONT

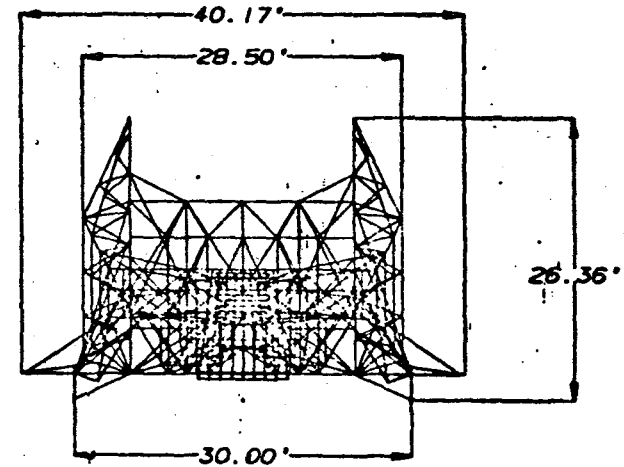

HIGH SPEED MAIN CARRIAGE

FIGURE 1

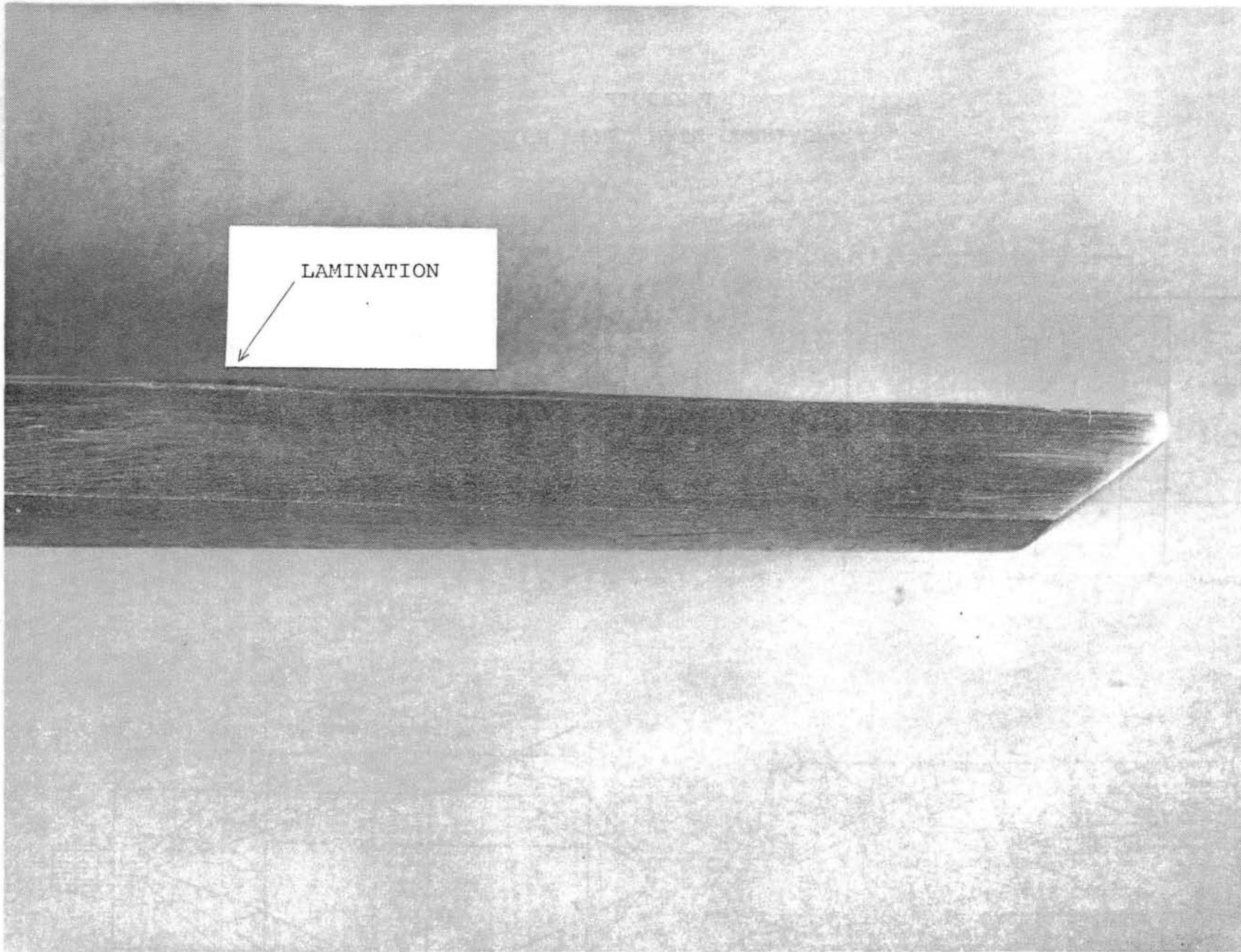

LAMINATION IN 6" DIA. TUBE
FIGURE 2

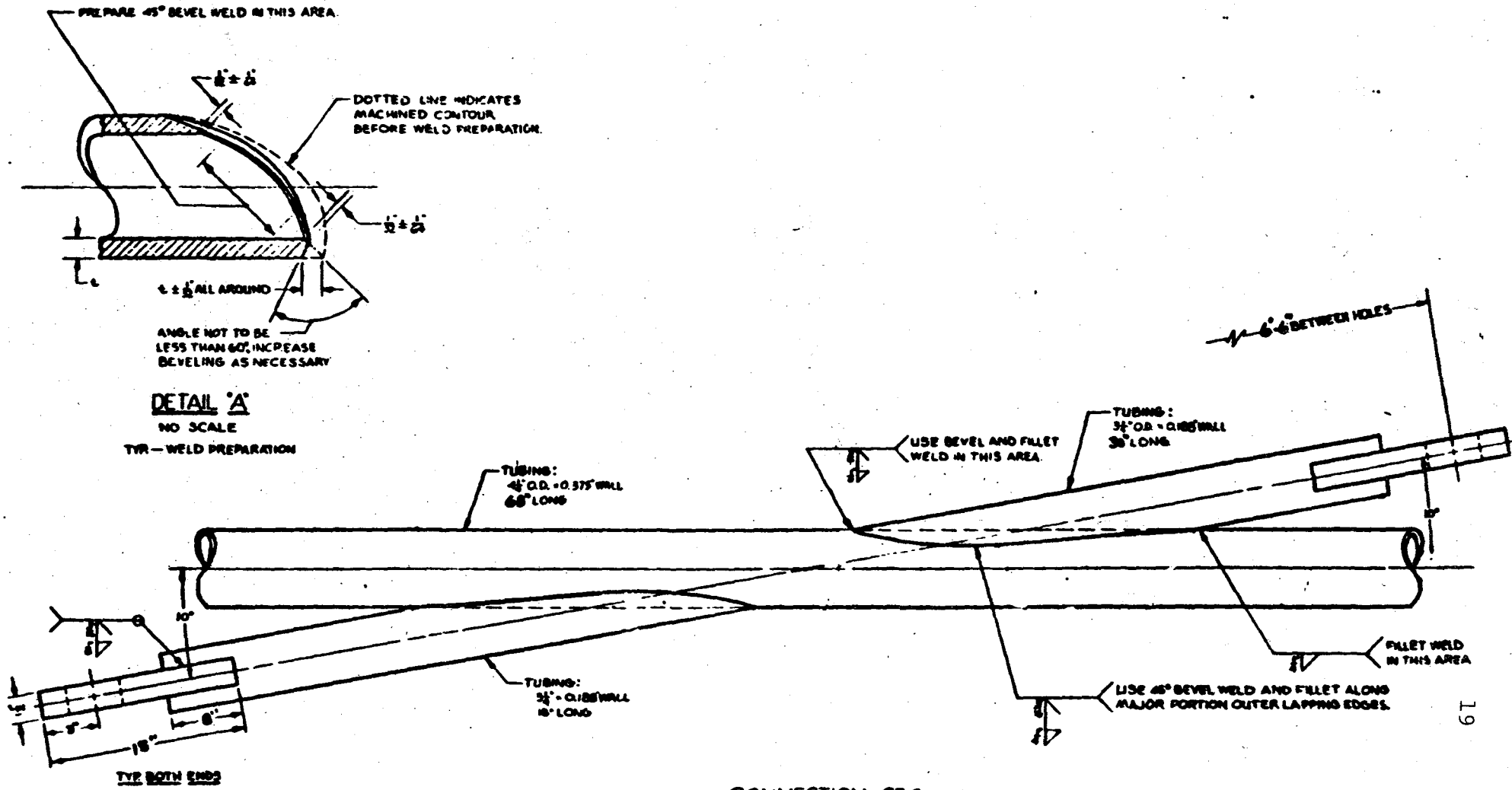

CONNECTION 836
SCALE: 3"=1'-0"

FIGURE 3

HEWLETT-PACKARD 8270-1004

KIPS

270
240
210
180
150
120
90
60
30

JOINT 836 TESTED 7-30-82

50.90 Sy
99400 LBS

75.90 Sy
141000 LBS

100.90 Sy
188000 LBS

108.90 Sy
203000 LBS

INCHES

CONNECTION 836 LOAD TO STRAIN
FIGURE 4

0 .1 .2 .3 .4

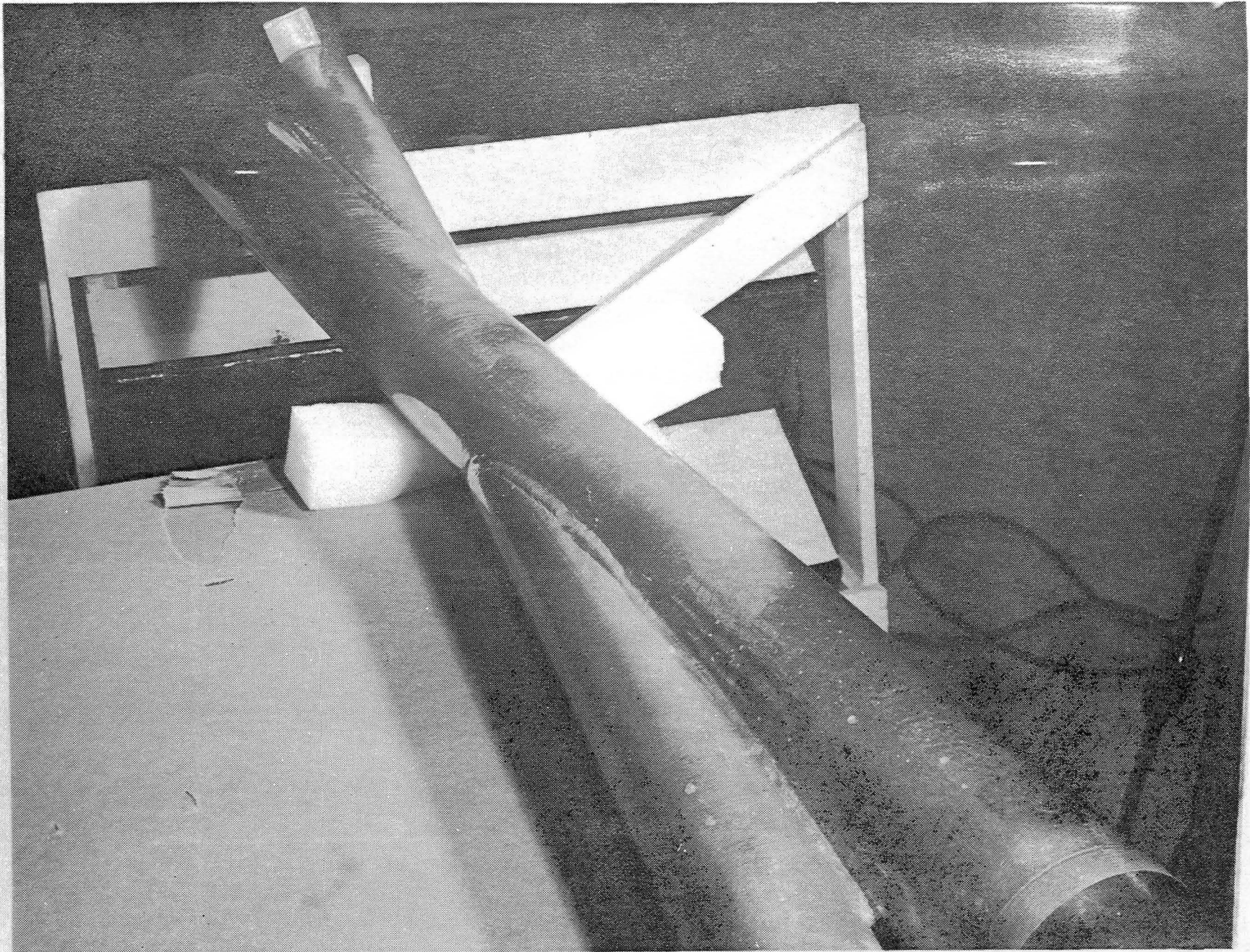

CONNECTION 836 AFTER TEST

FIGURE 5

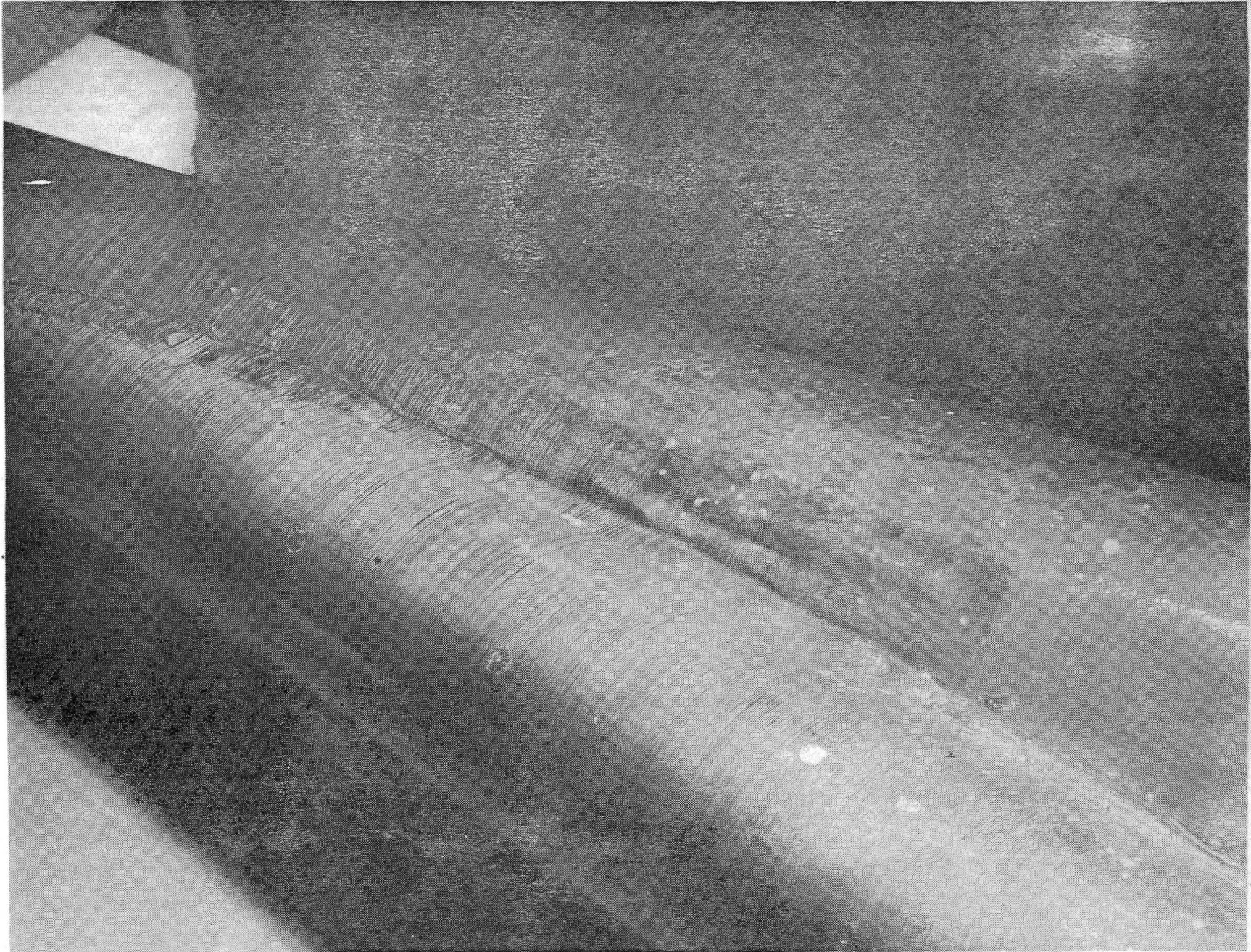

CONNECTION 836 AFTER TEST

FIGURE 6

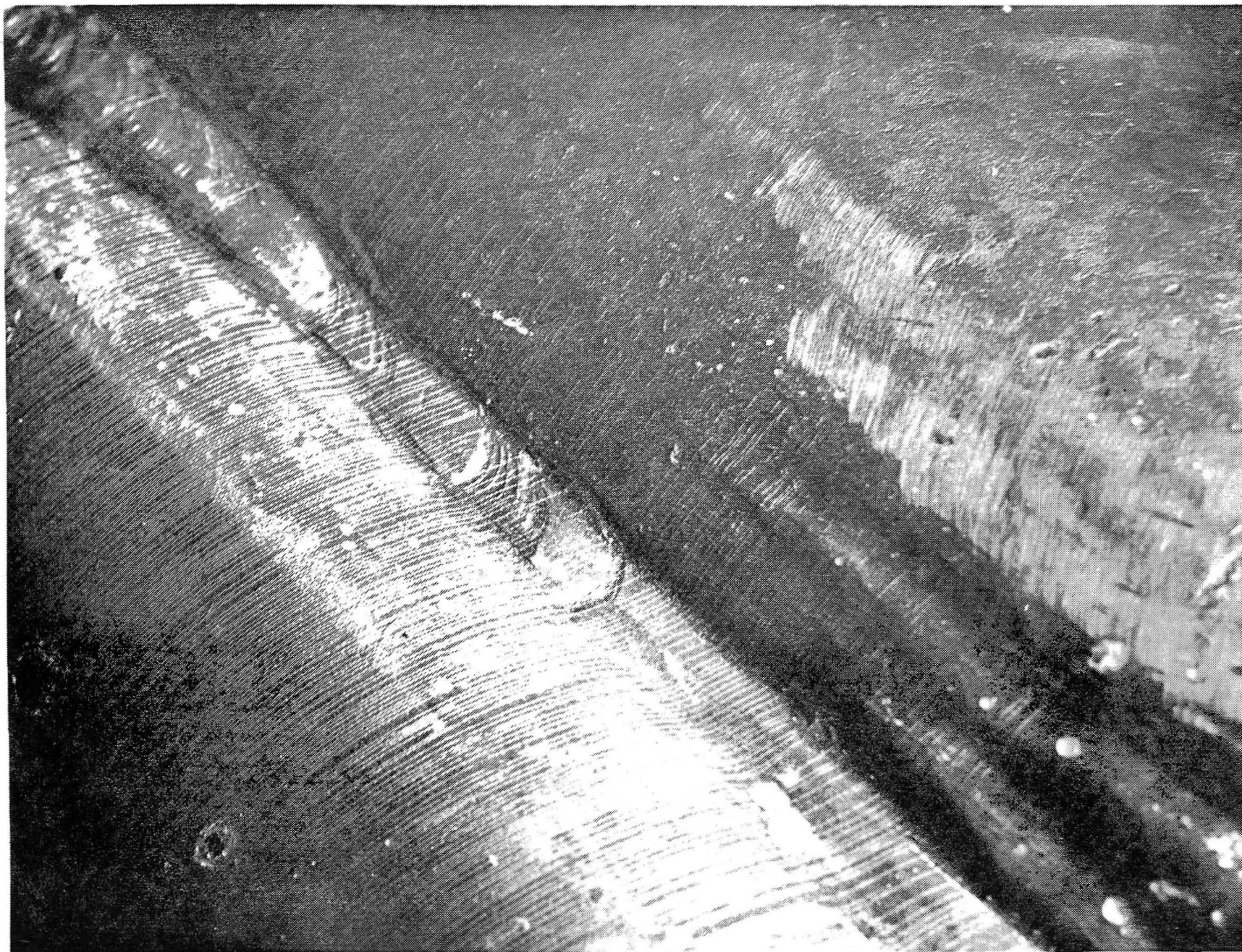

CONNECTION 836 AFTER TEST

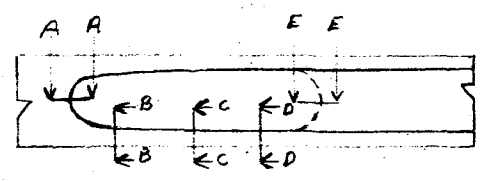
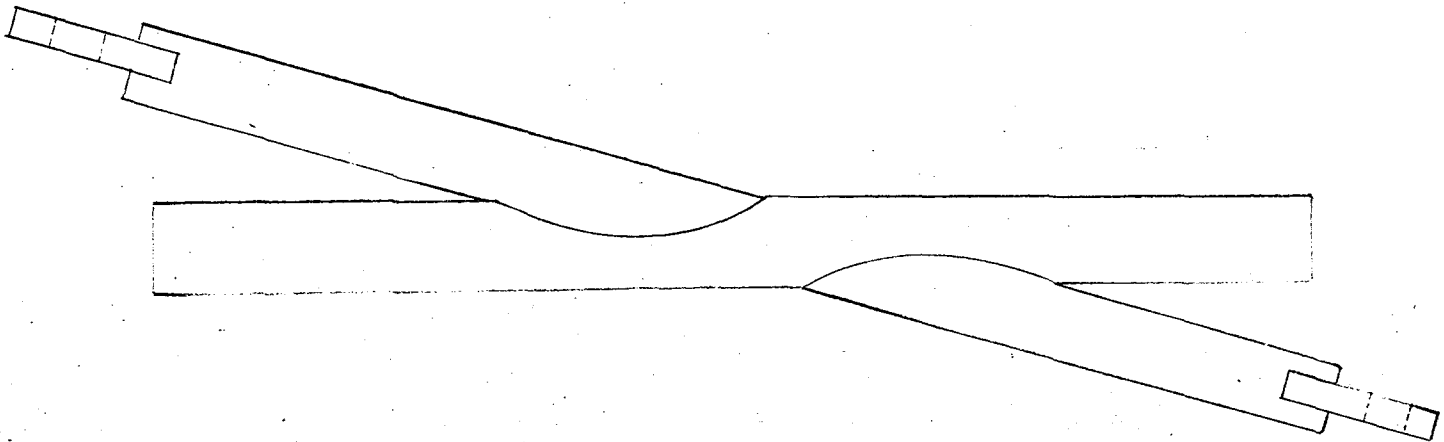

CONNECTION 836 MACROSECTION LOCATION

FIGURE 8

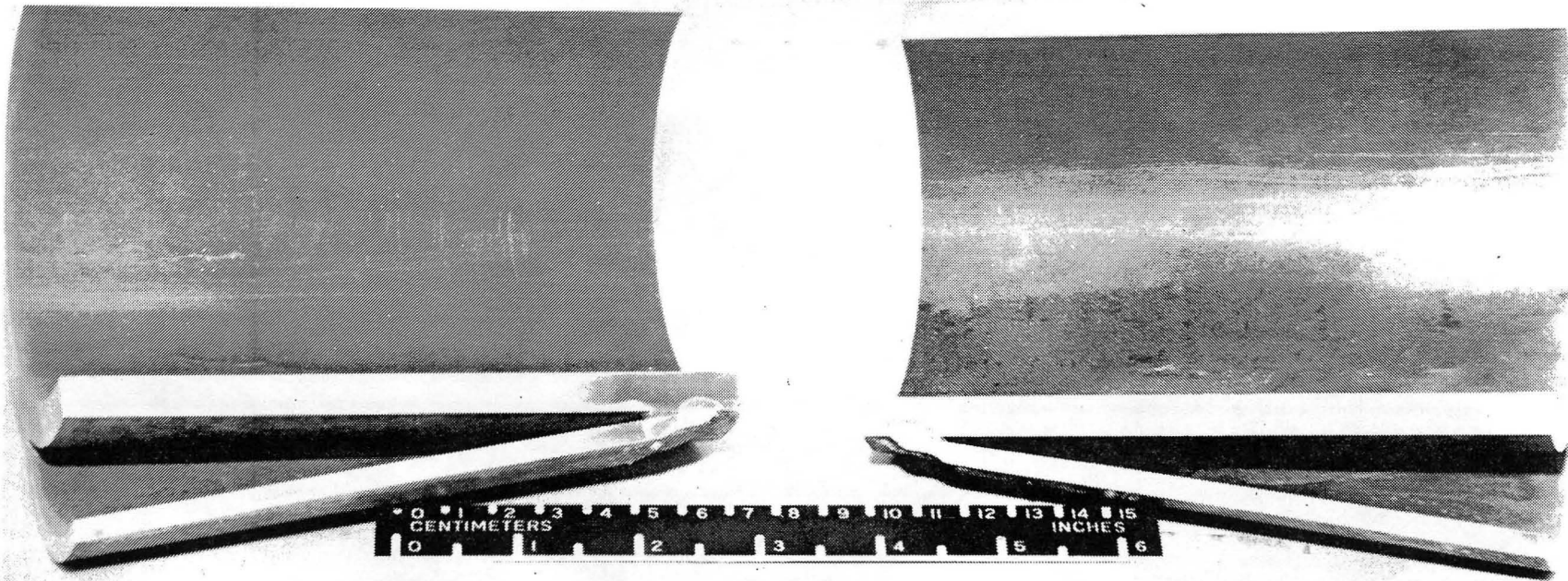

CONNECTION 836 MACROSECTION A-A

FIGURE 9

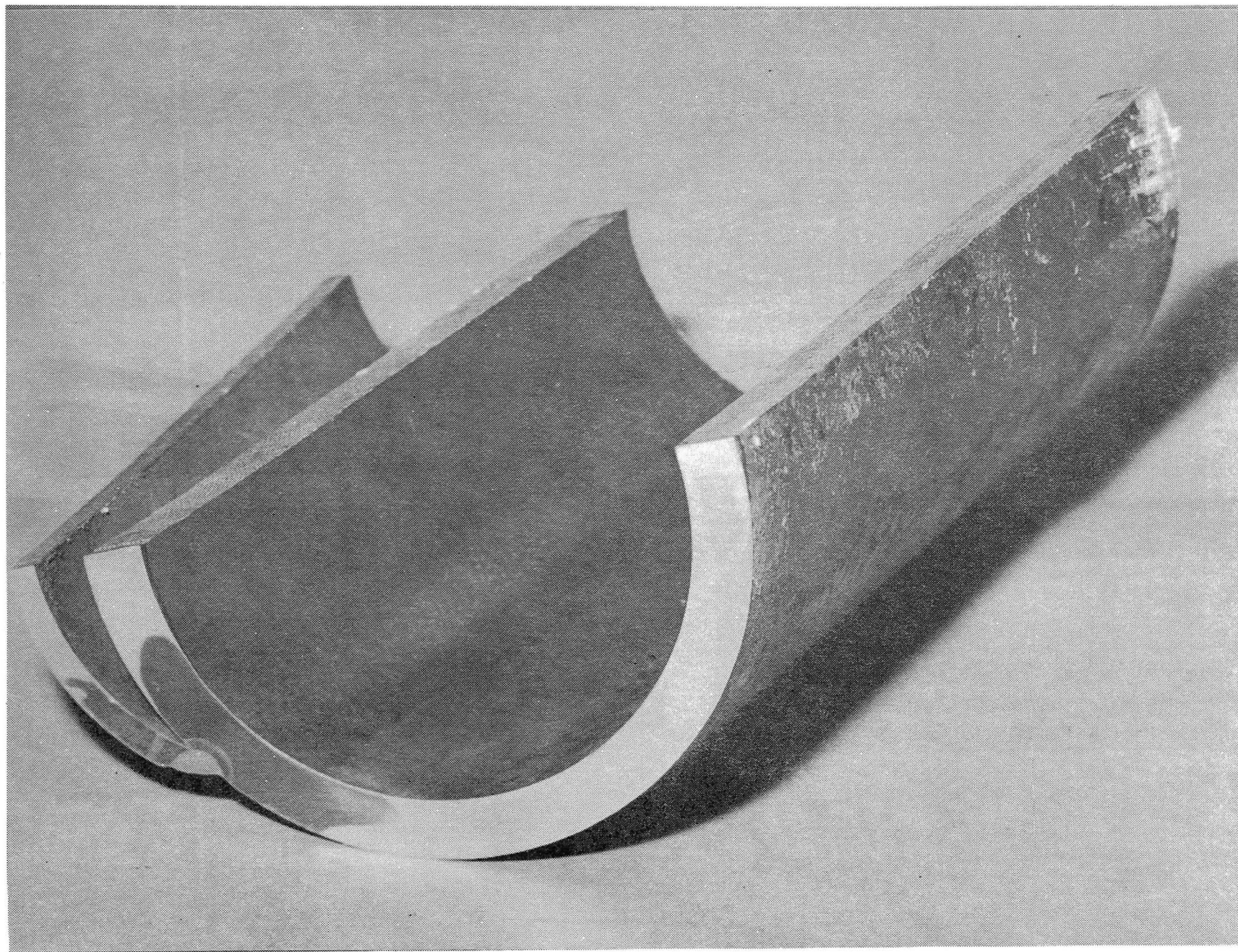

CONNECTION 836 MACROSECTION B-B

FIGURE 10

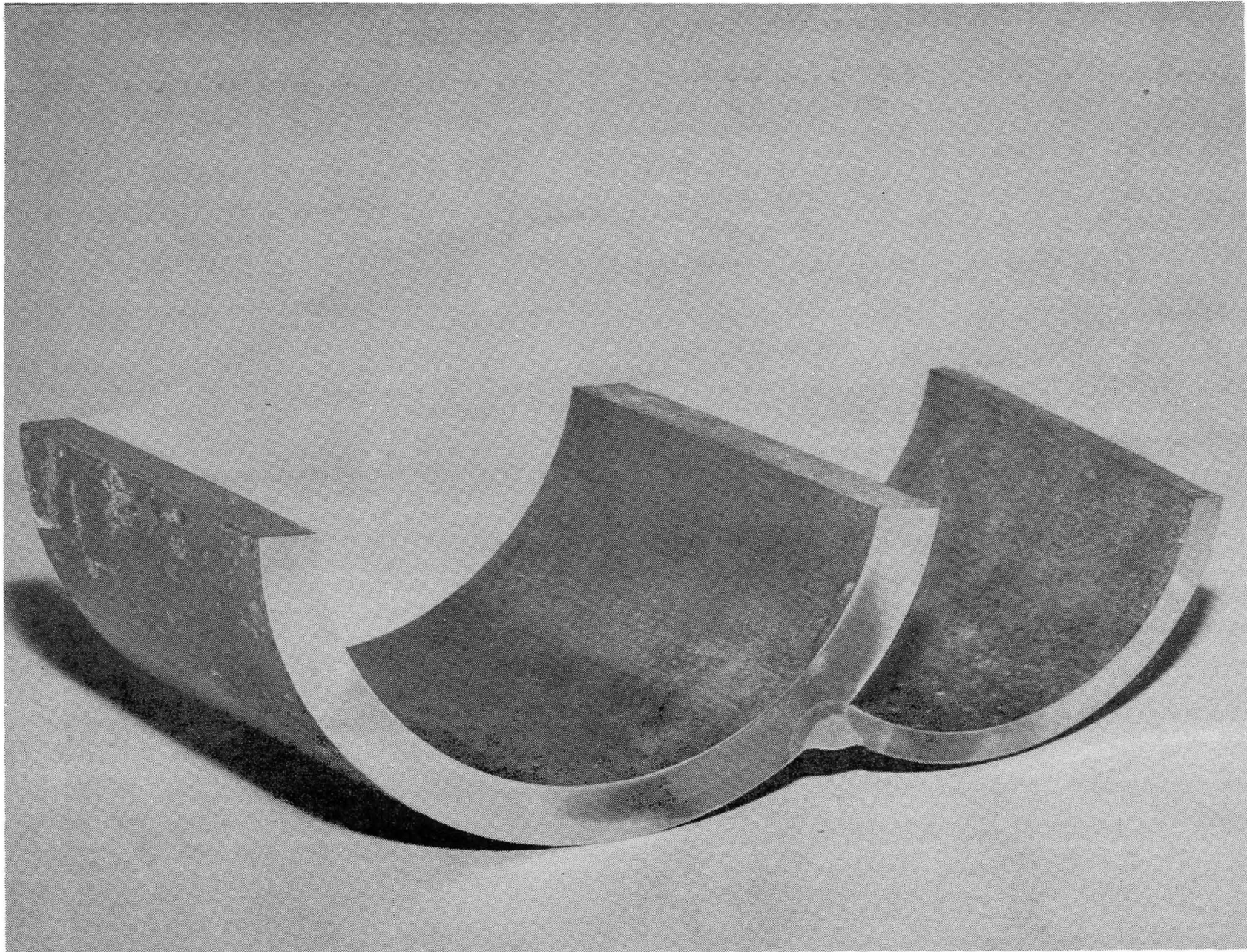

CONNECTION 836 MACROSECTION C-C

FIGURE 11

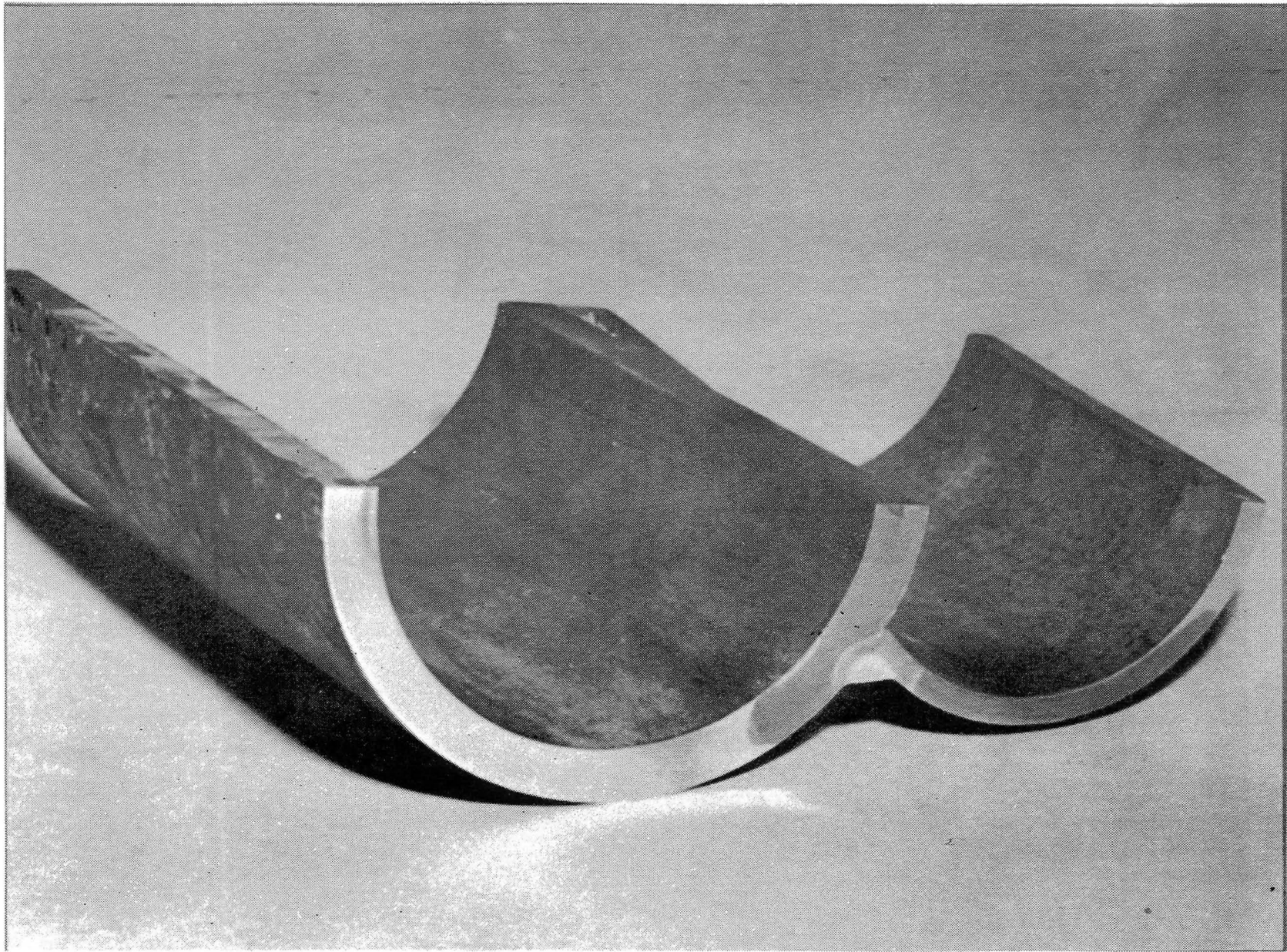

CONNECTION 836 MACROSECTION D-D

FIGURE 12

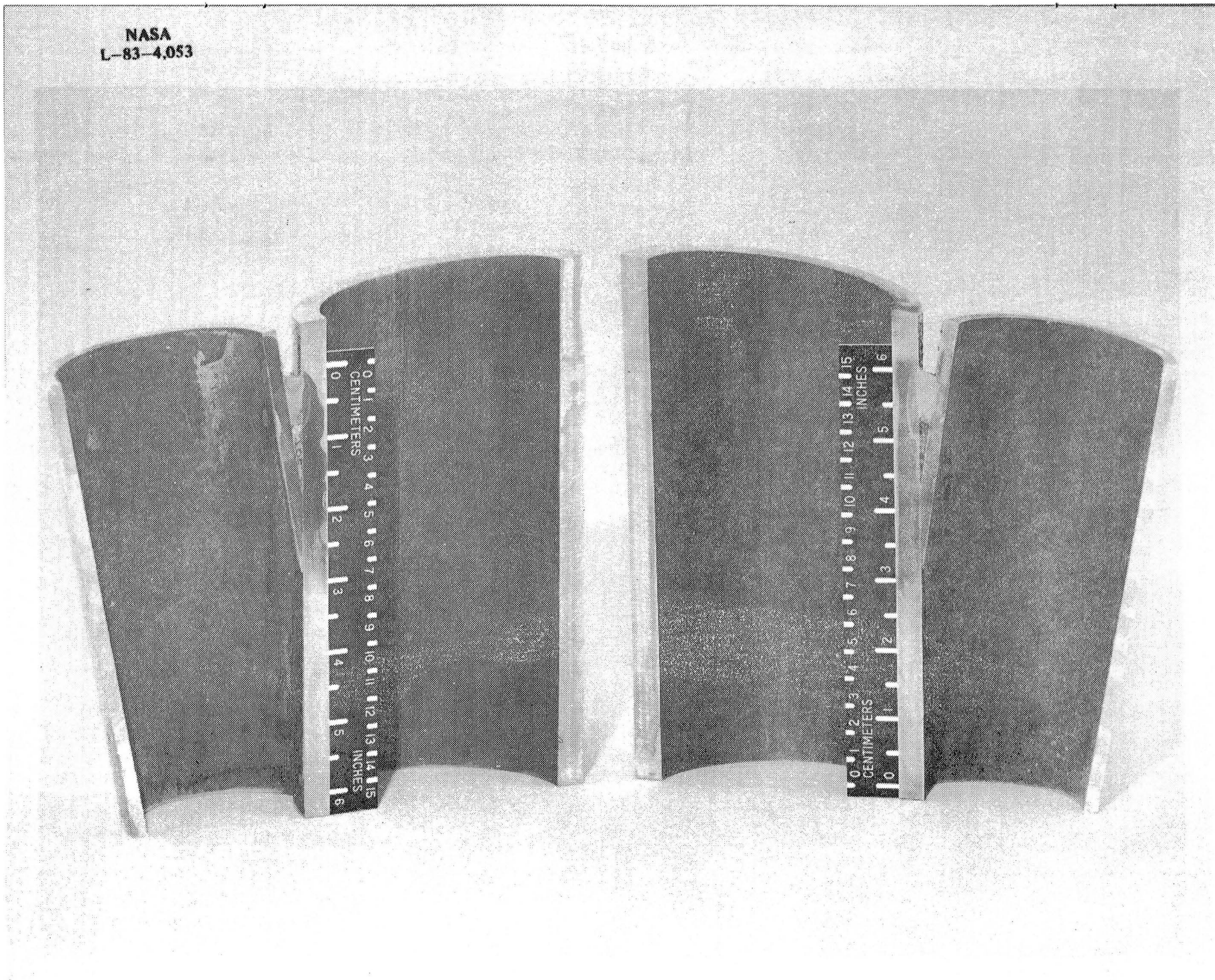

CONNECTION 836 MACROSECTION E-E

FIGURE 13

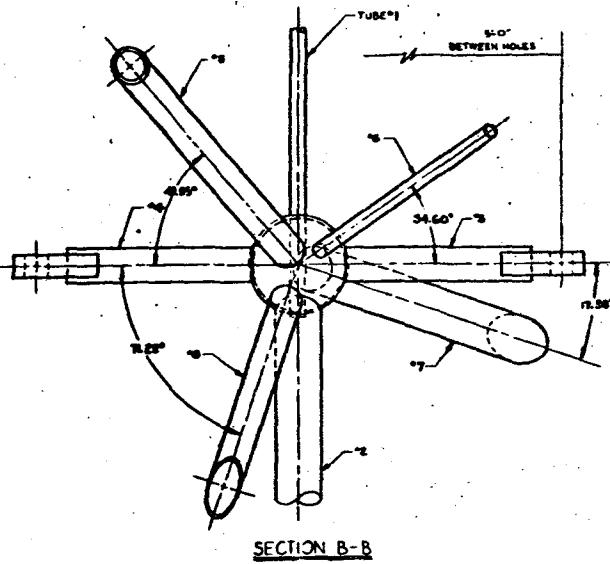
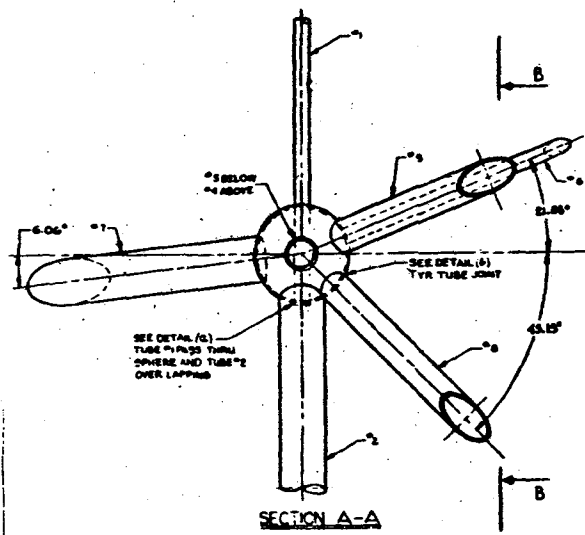
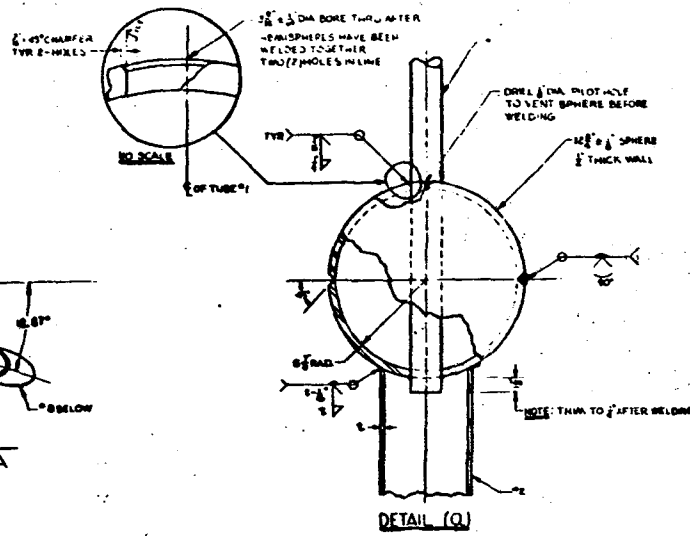
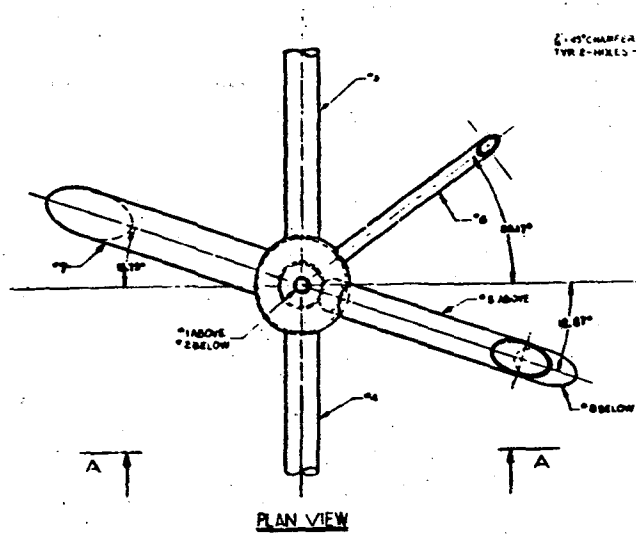

TUBE SIZES		
NO	SIZE	L.G.
6	2.00"OD x 0.180" WALL	2'-0"
7	2.25"OD x 0.188" WALL	3'-0"
3, 4, 5, 8	4.25"OD x 0.375" WALL	2'-0"
2 & 7	6.00"OD x 0.250" WALL	2'-0"

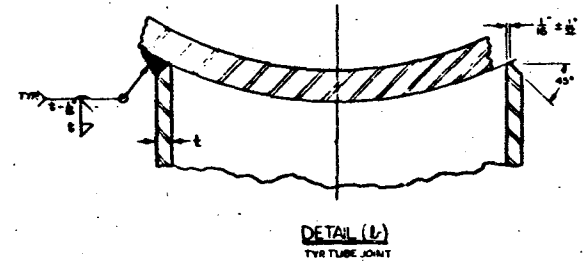

CONNECTION 314

FIGURE 14

STRAIN GAGE LOCATIONS

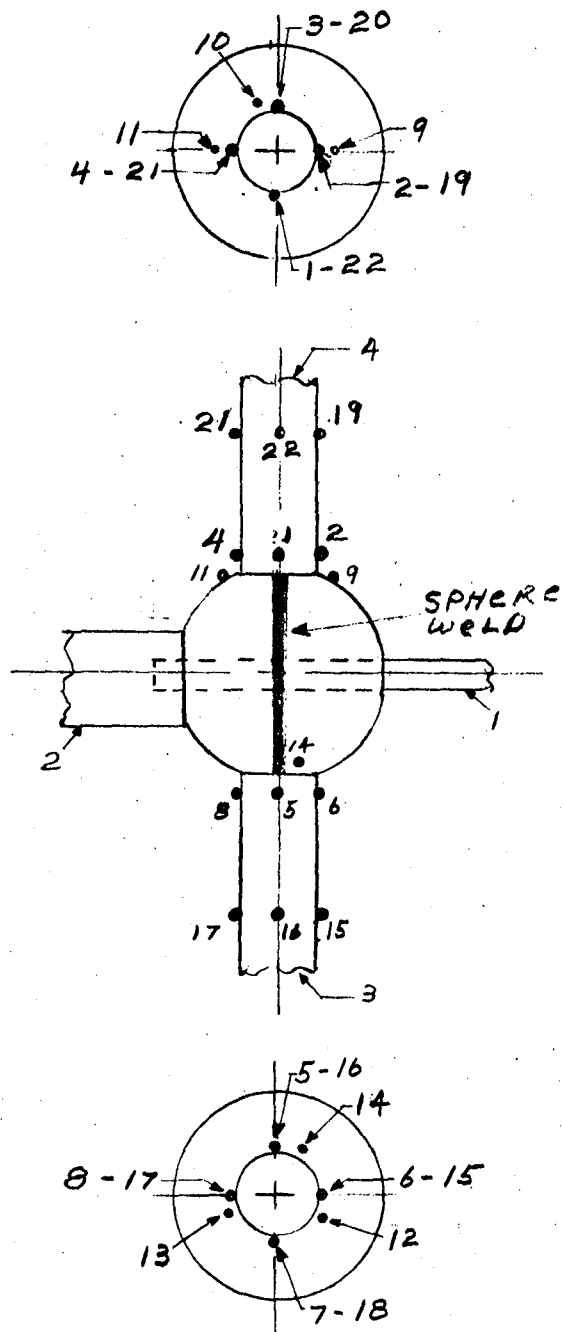

CONNECTION 314 STRAIN GAGE LOCATIONS

FIGURE 15



CONNECTION 314 TENSION TEST

FIGURE 16

TEST 314

RUN	+
SG-1	○
SG-2	□
SG-3	◇
SG-4	△

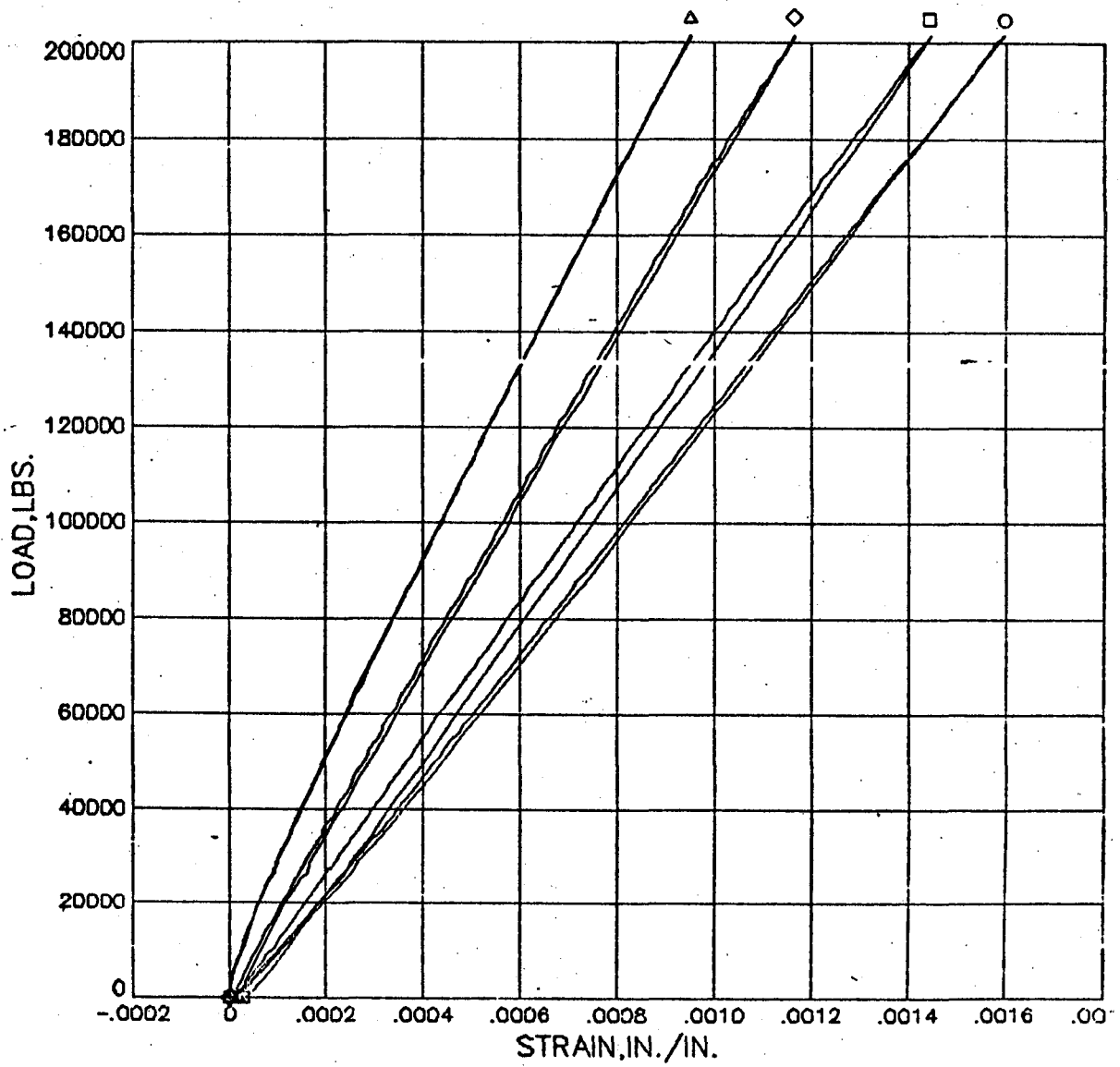

CONNECTION 314 TENSION TEST

FIGURE 17A

TEST 314

RUN	4
S0-5	○
S0-6	□
S0-7	◇
S0-8	△

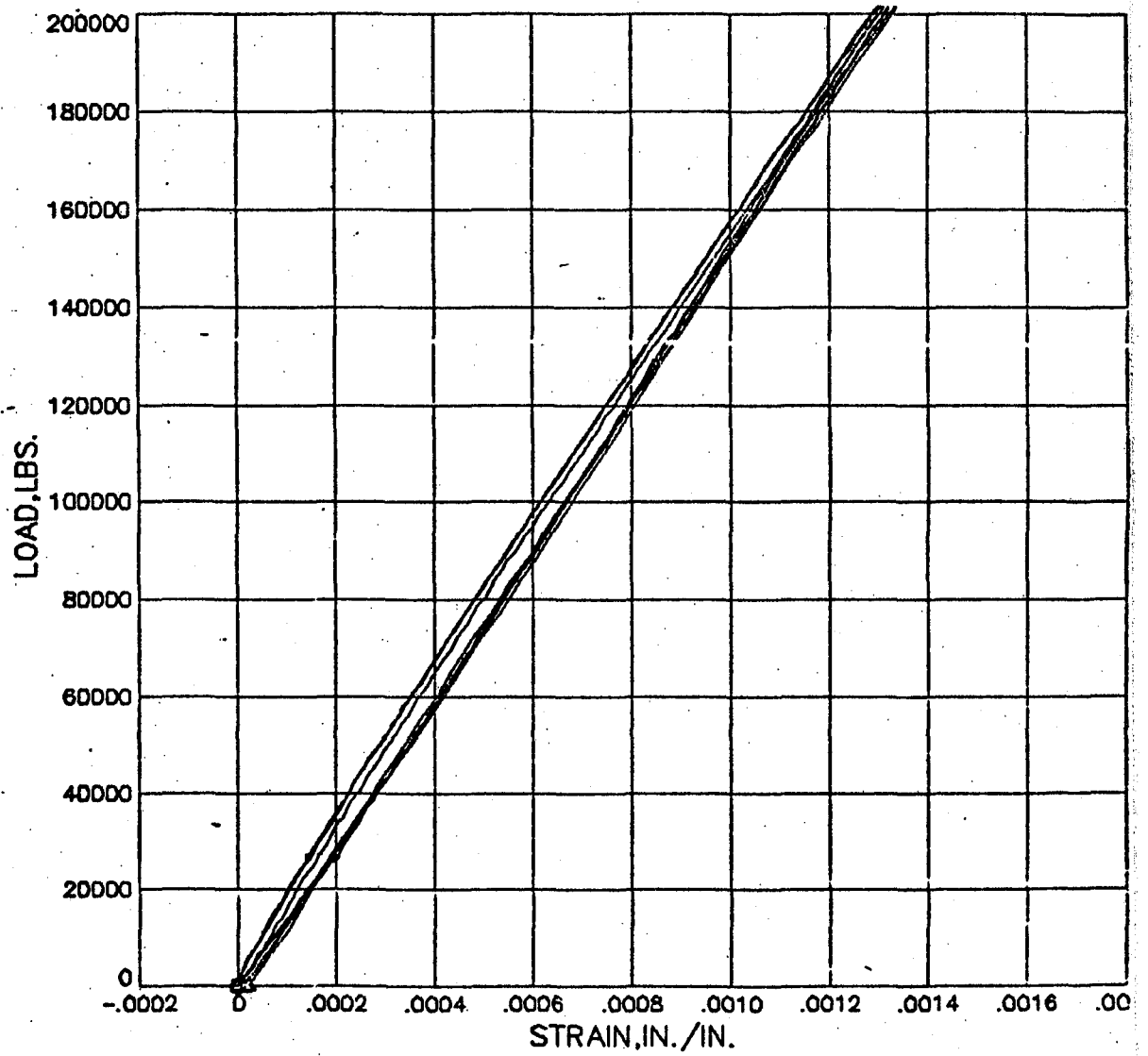

CONNECTION 314 TENSION TEST

FIGURE 17B

TEST 314

RUN 4
S0-9 ○
S0-10 □
S0-11 ◇

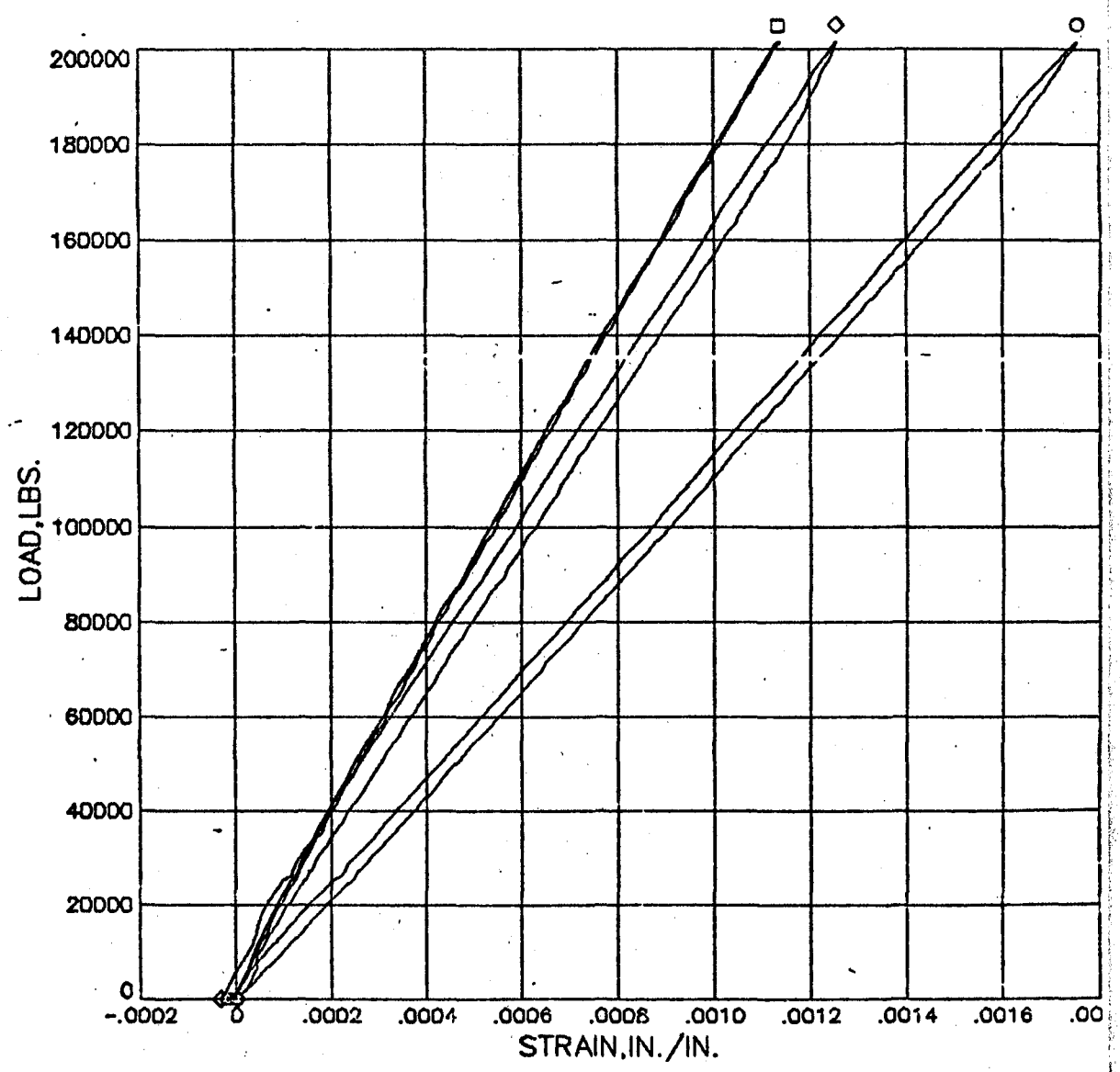

CONNECTION 314 TENSION TEST

FIGURE 17C

TEST 314

RUN	4
S0-12	○
S0-13	□
S0-14	◇

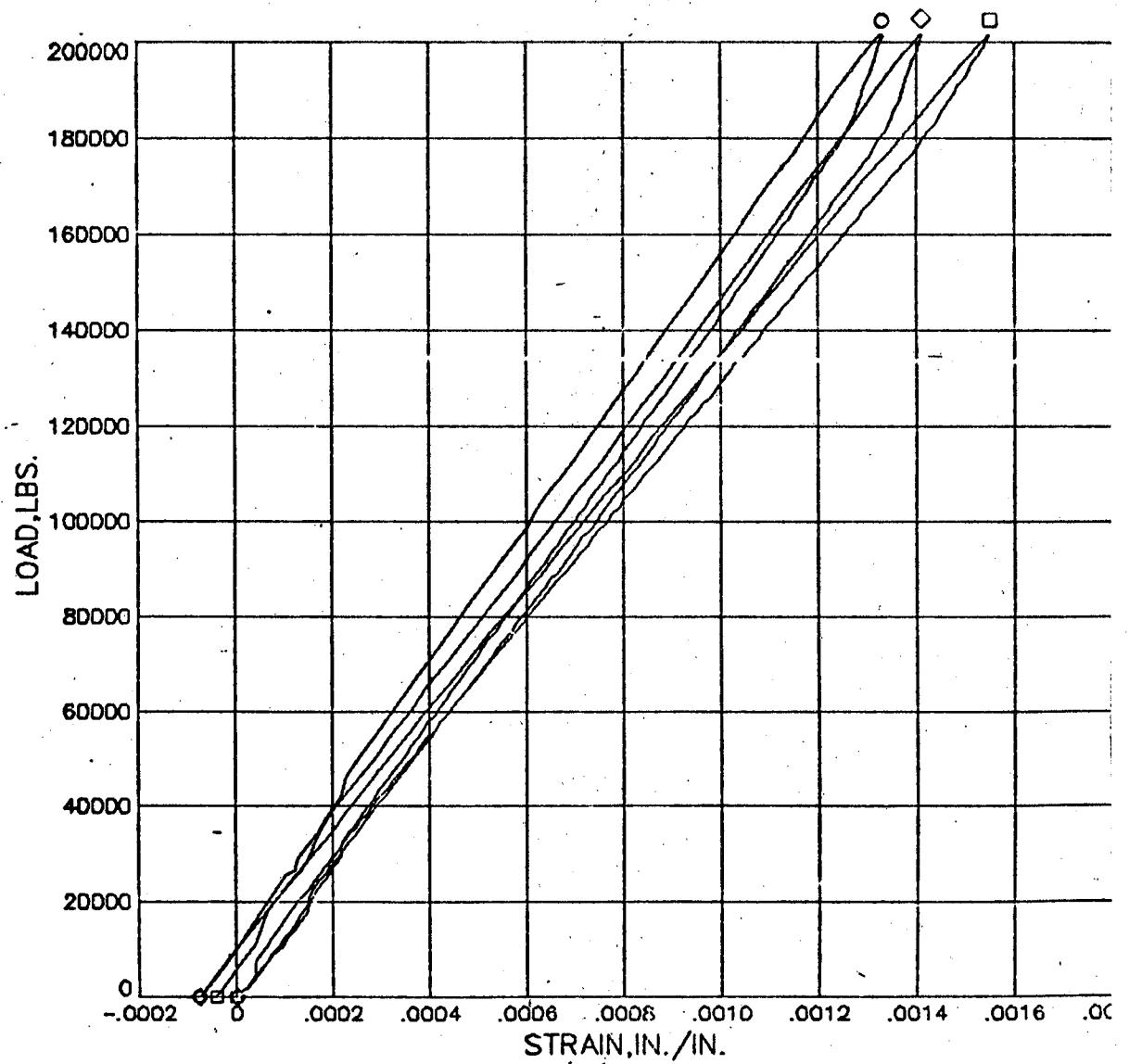

CONNECTION 314 TENSION TEST

FIGURE 17D

TEST 314

- RUN 4
- S0-15 ○
- S0-16 □
- S0-17 ◇
- S0-18 △

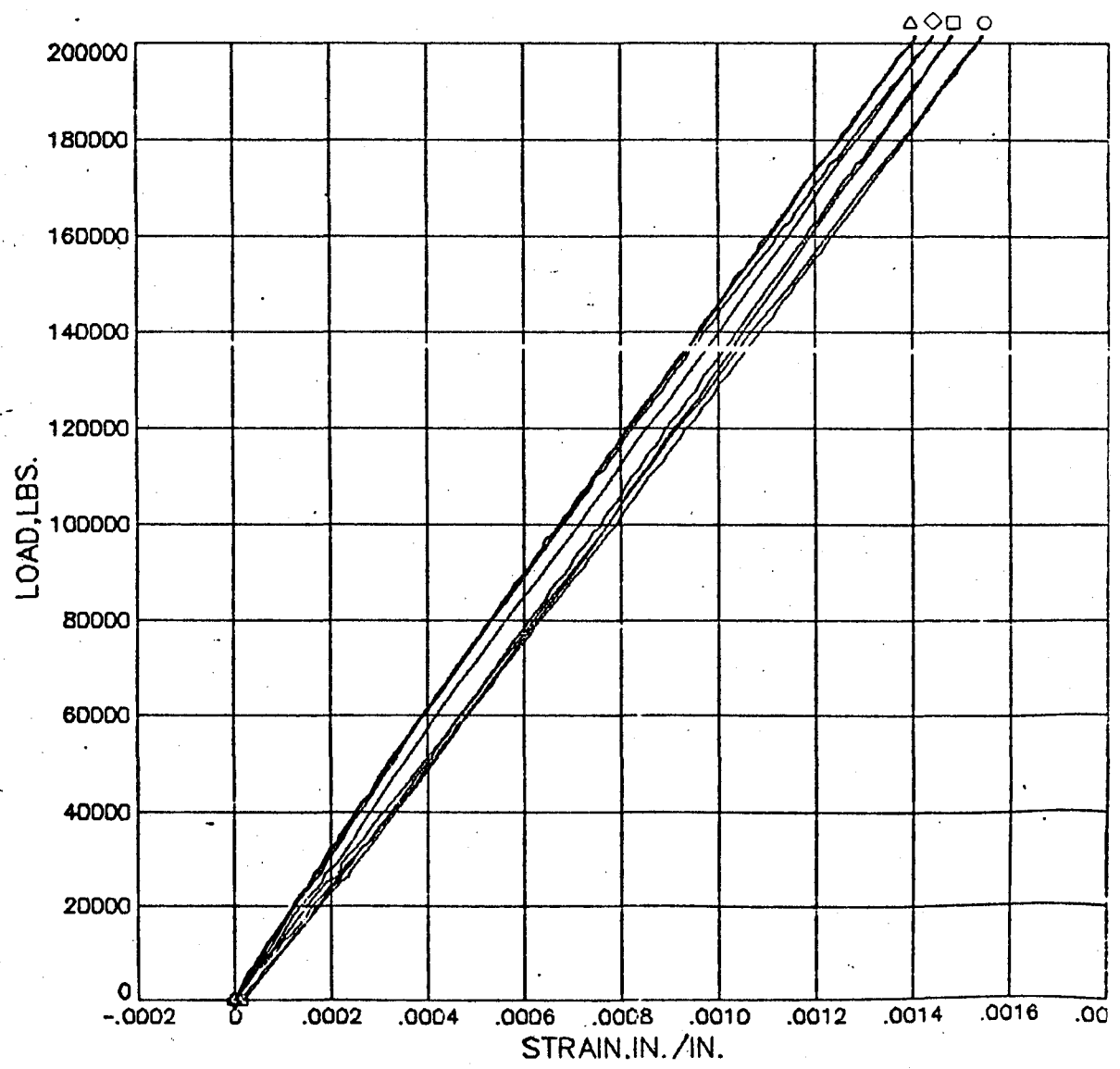

CONNECTION 314 TENSION TEST

FIGURE 17E

TEST 314

RUN	4
S0-18	○
S0-20	□
S0-21	◇
S0-22	△

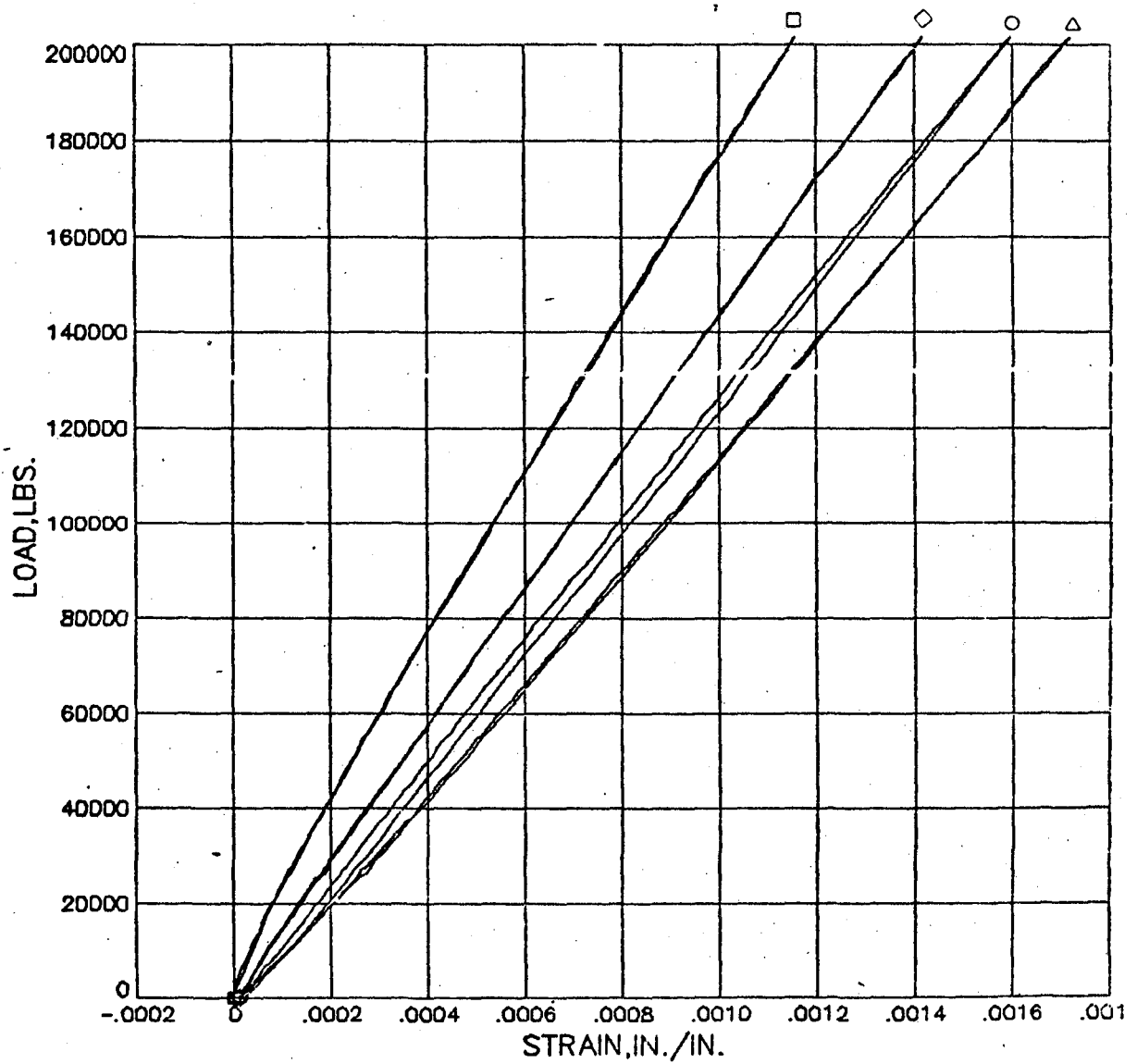

CONNECTION 314 TENSION TEST

FIGURE 17F

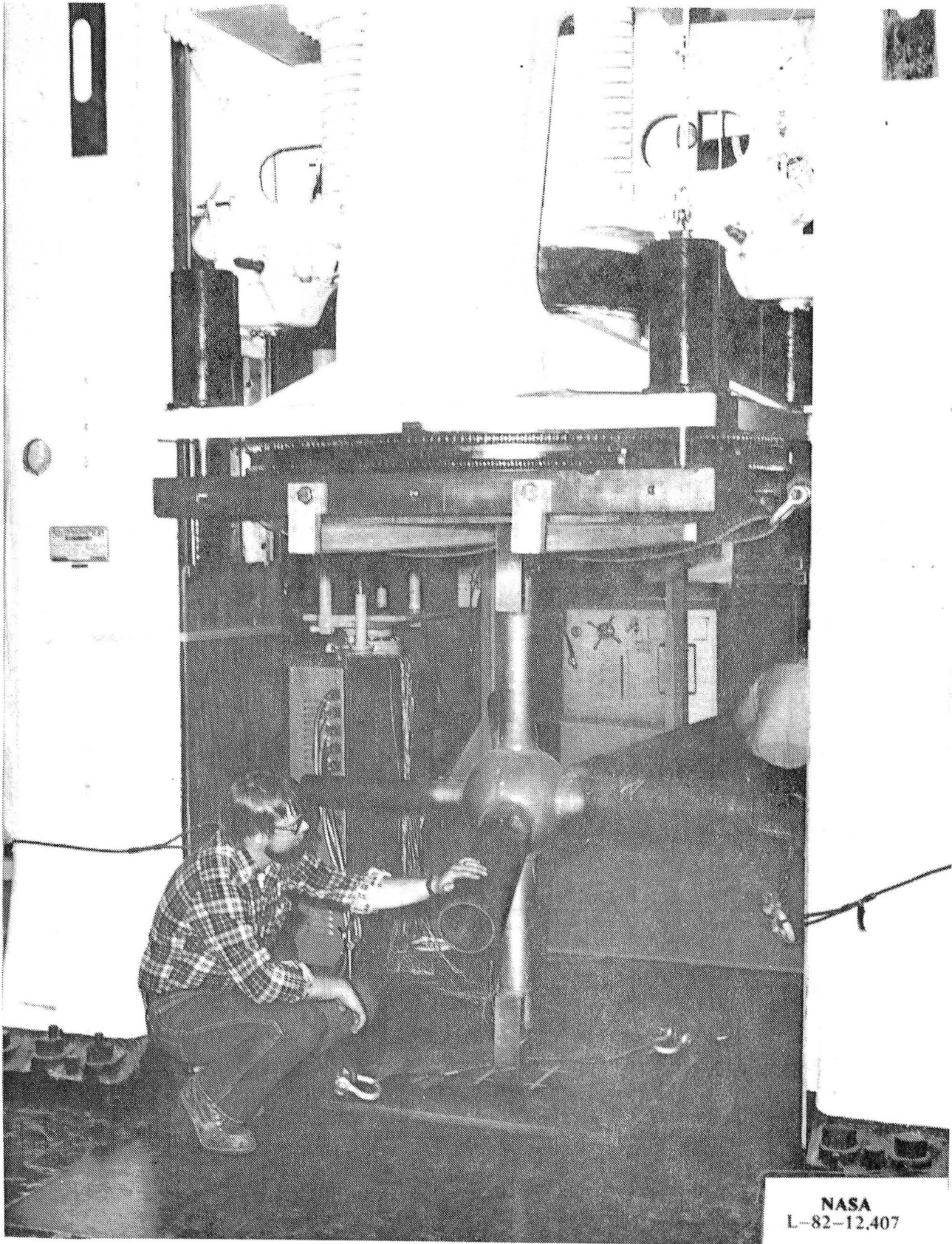

CONNECTION 314 COMPRESSION TEST

FIGURE 18

TEST 314

- RUN 6
- S0-1 ○
- S0-2 □
- S0-3 ◇
- S0-4 △

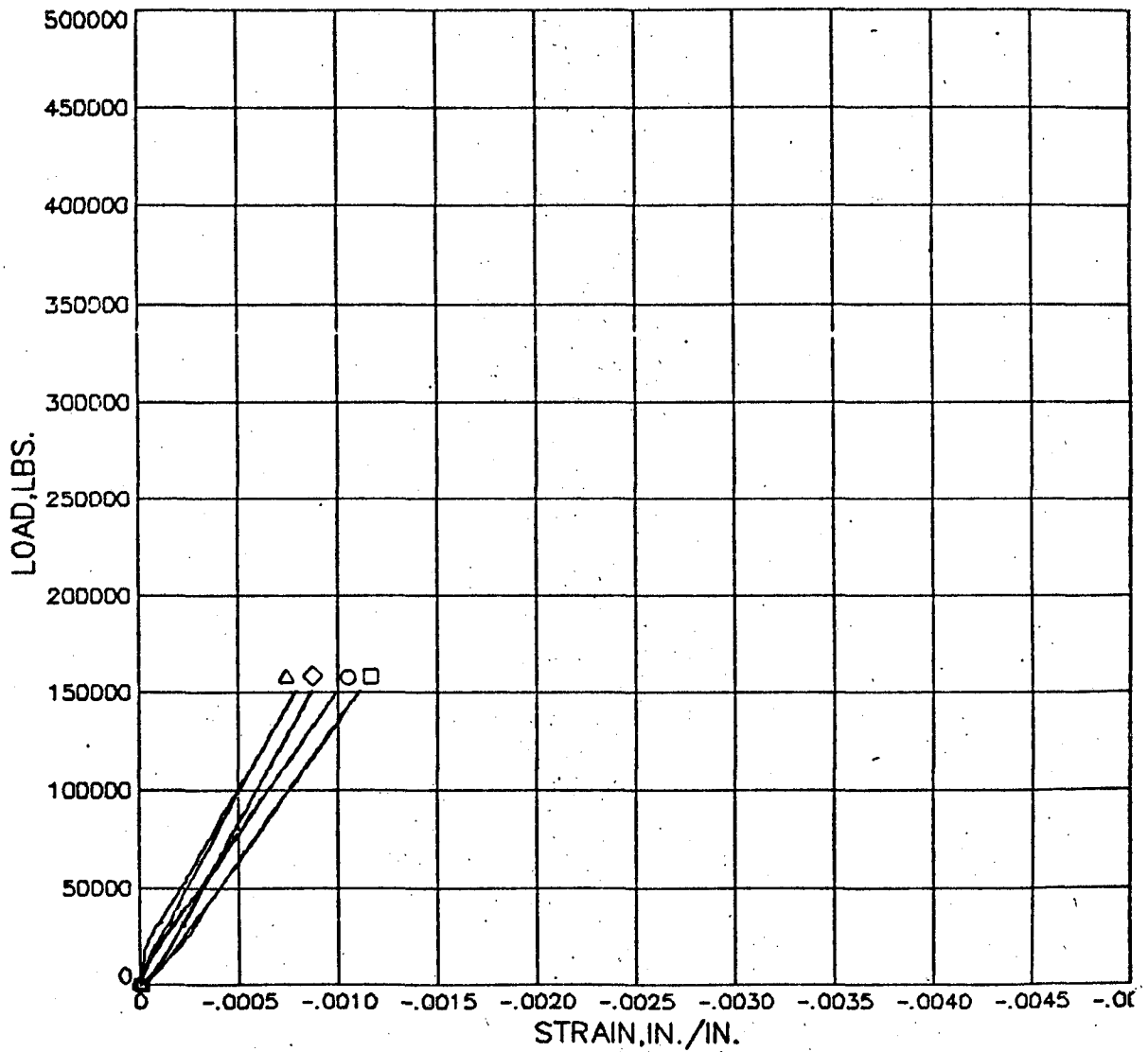

CONNECTION 314 COMPRESSION TEST

FIGURE 19A

TEST 314

RUN	■
SG-5	○
SG-6	□
SG-7	◇
SG-8	△

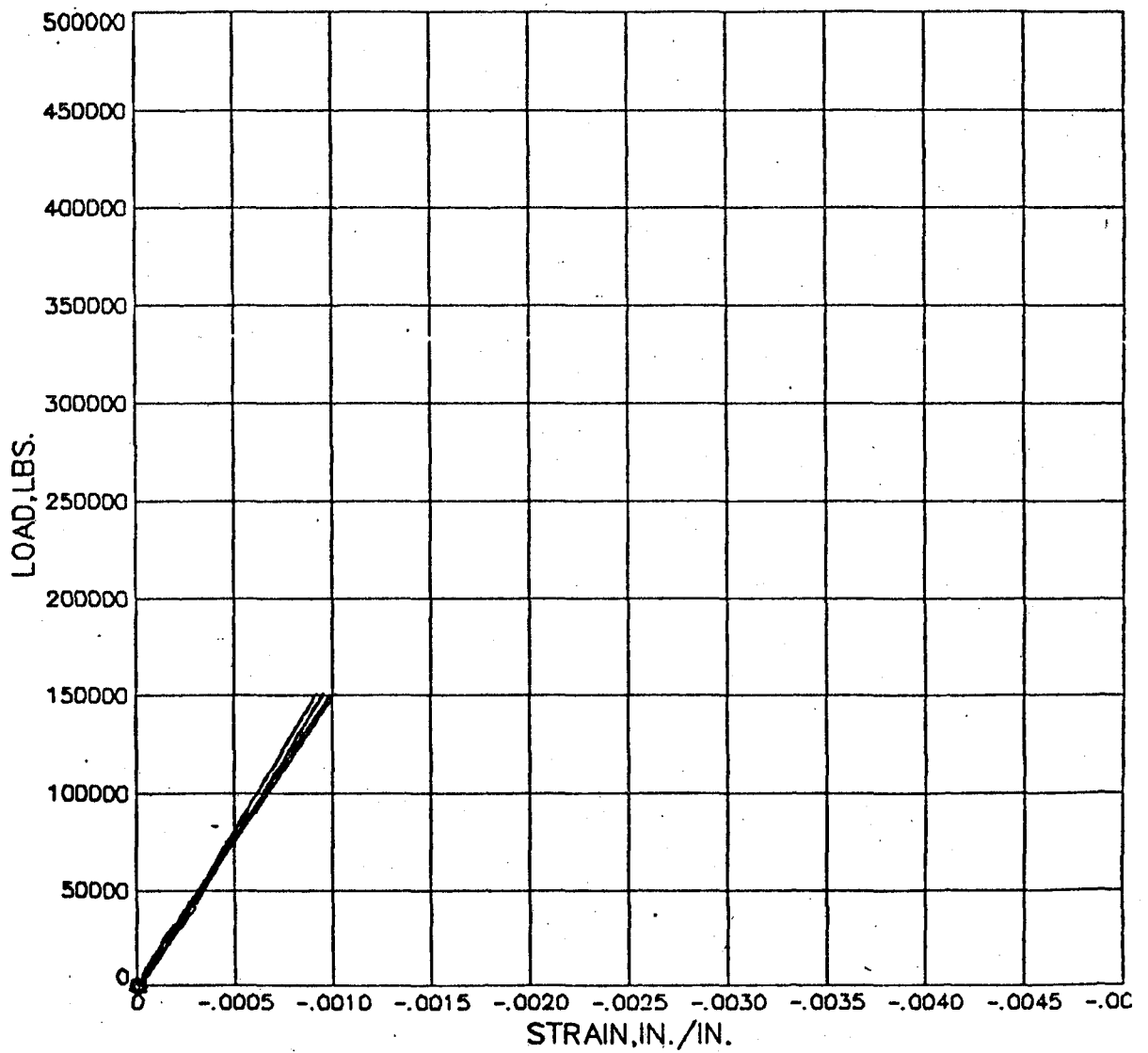

CONNECTION 314 COMPRESSION TEST

FIGURE 19B

TEST 314

- RUN ■
- S0-9 ○
- S0-10 □
- S0-11 ◇

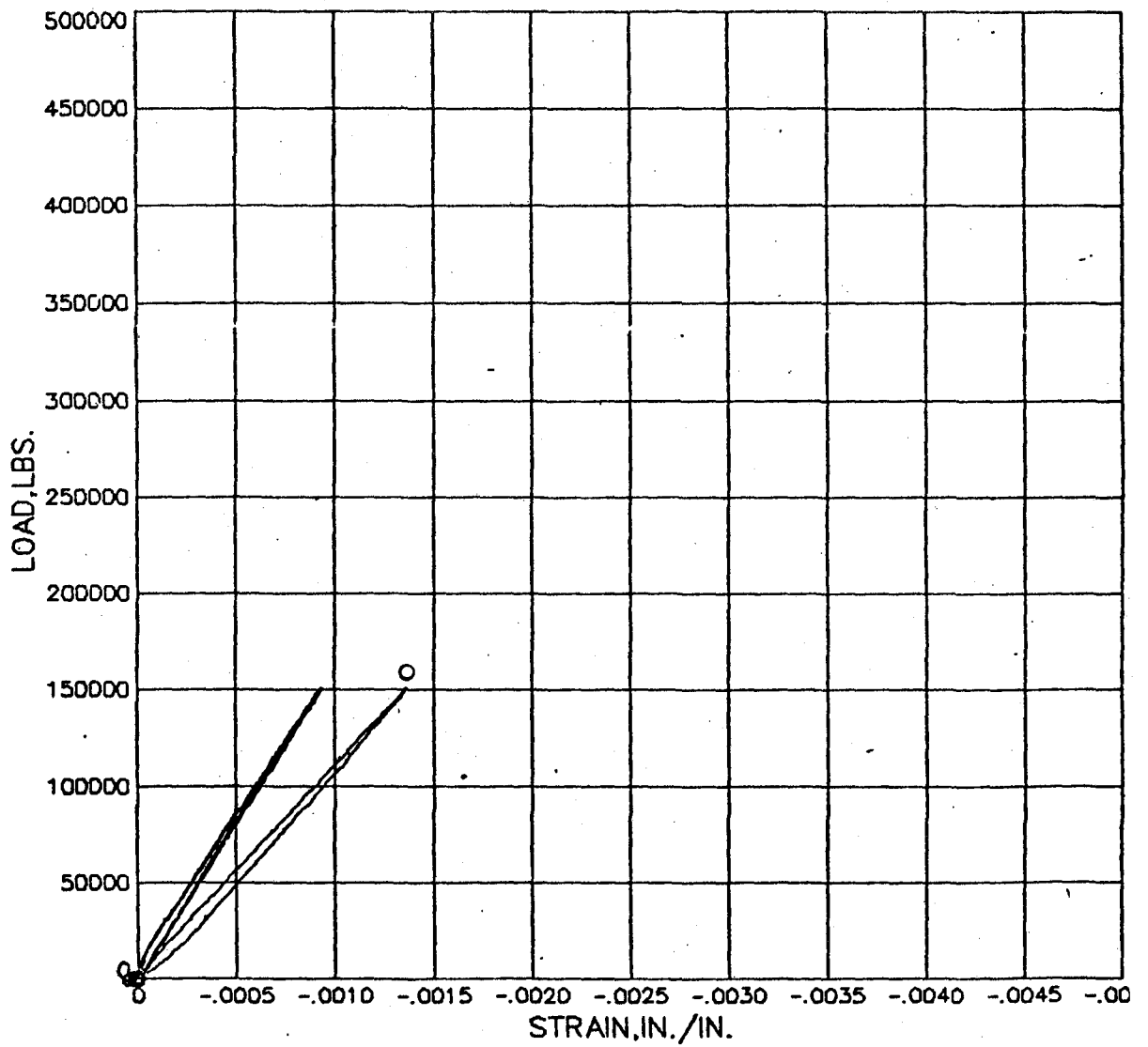

CONNECTION 314 COMPRESSION TEST

FIGURE 19C

TEST 314

RUN	■
S0-12	○
S0-13	□
S0-14	◇

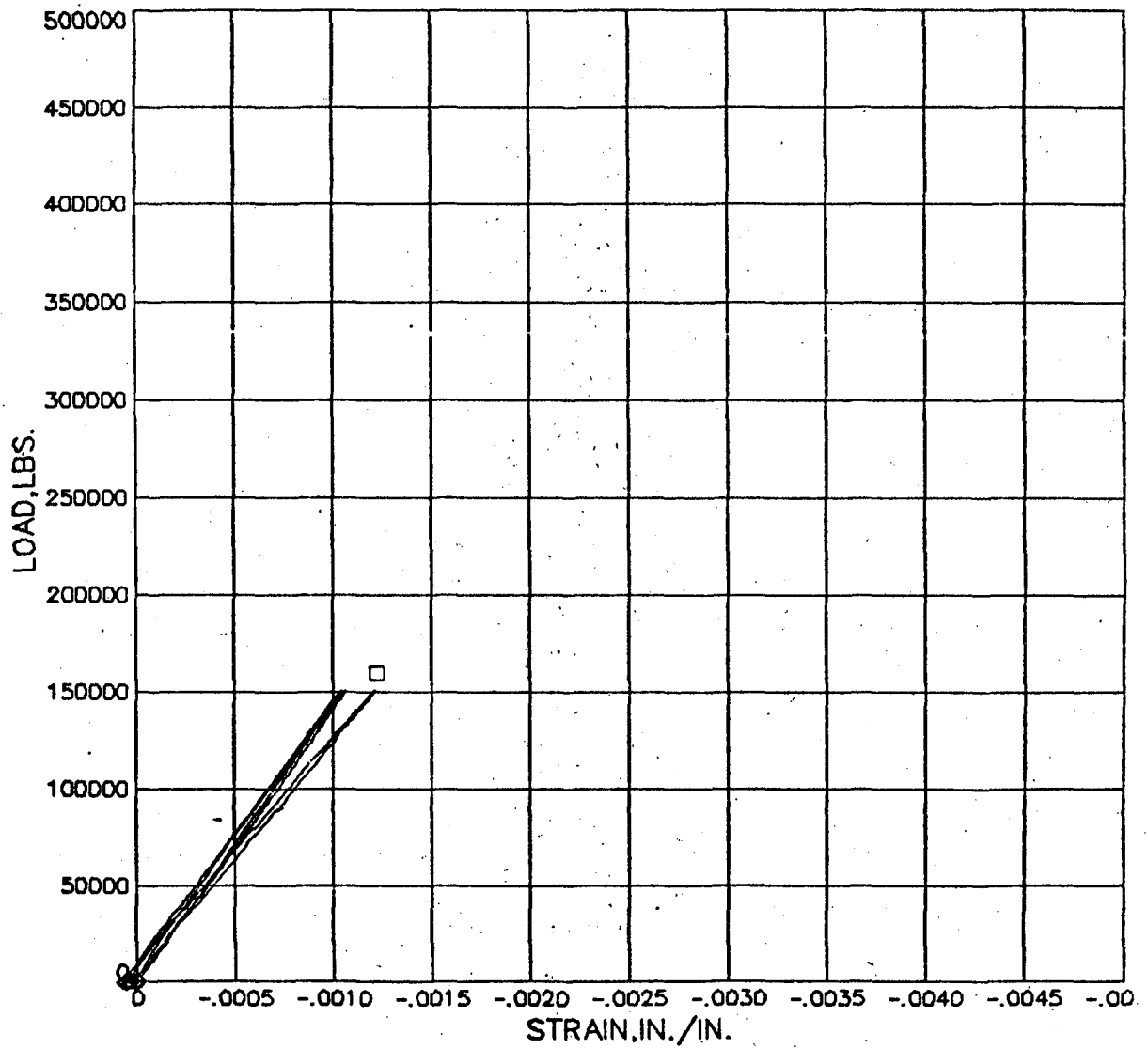

CONNECTION 314 COMPRESSION TEST

FIGURE 19D

TEST 314

RUN	•
S0-15	○
S0-16	□
S0-17	◇
S0-18	△

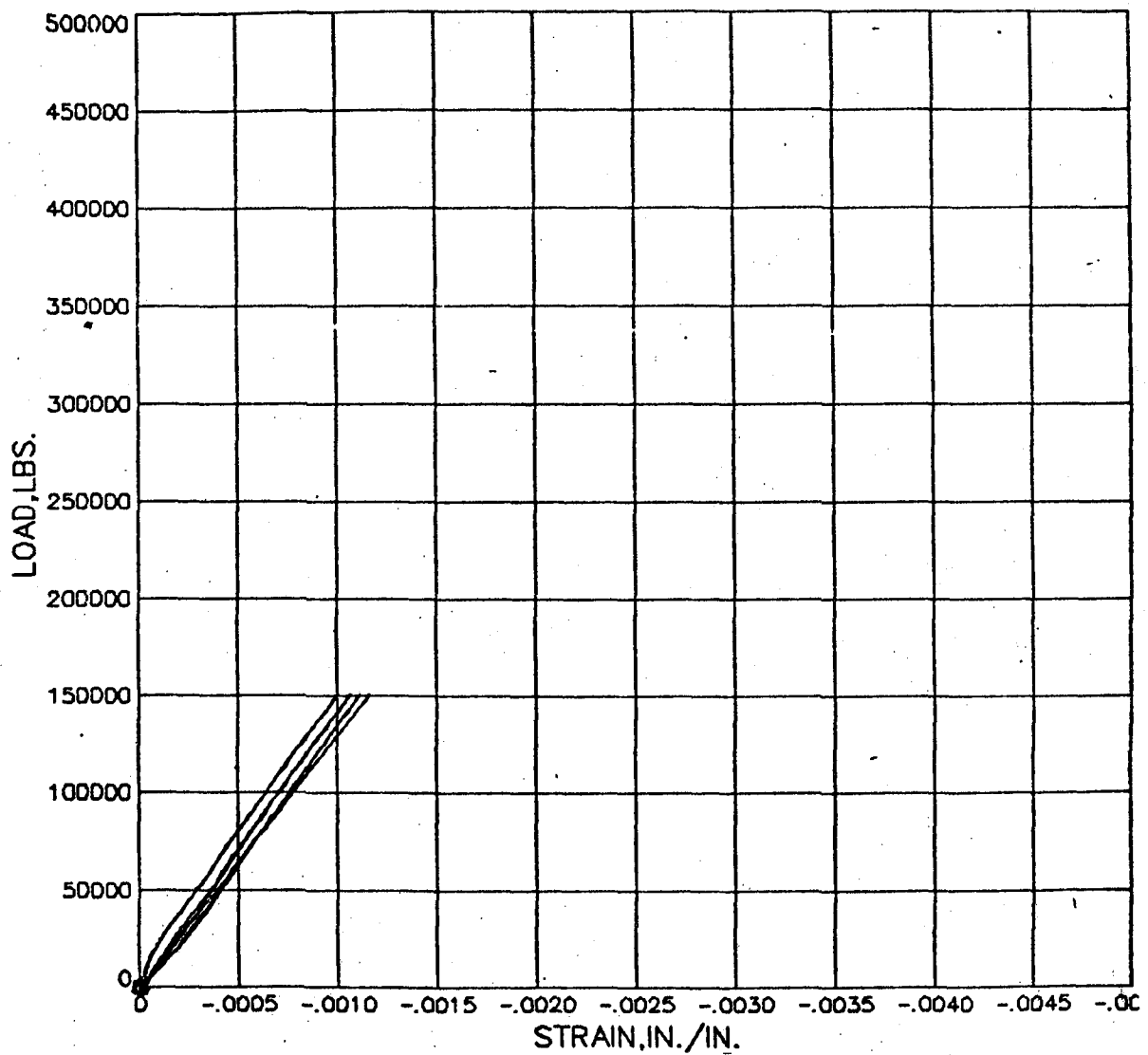

CONNECTION 314 COMPRESSION TEST

FIGURE 19E

TEST 314

RUN	•
S0-19	○
S0-20	□
S0-21	◇
S0-22	△

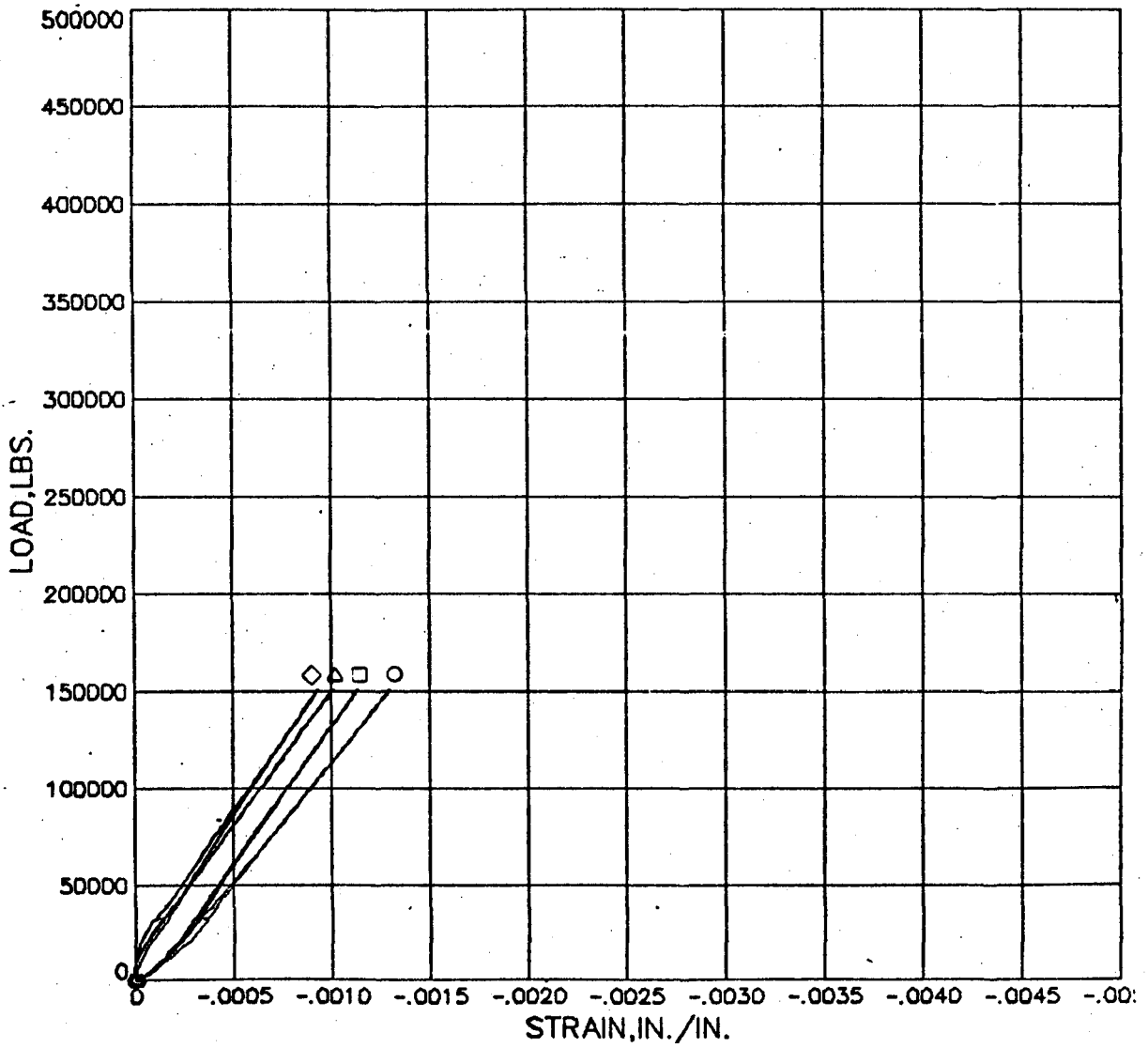

CONNECTION 314 COMPRESSION TEST

FIGURE 19F

TEST 314

RUN	7
S0-1	○
S0-2	□
S0-3	◇
S0-4	△

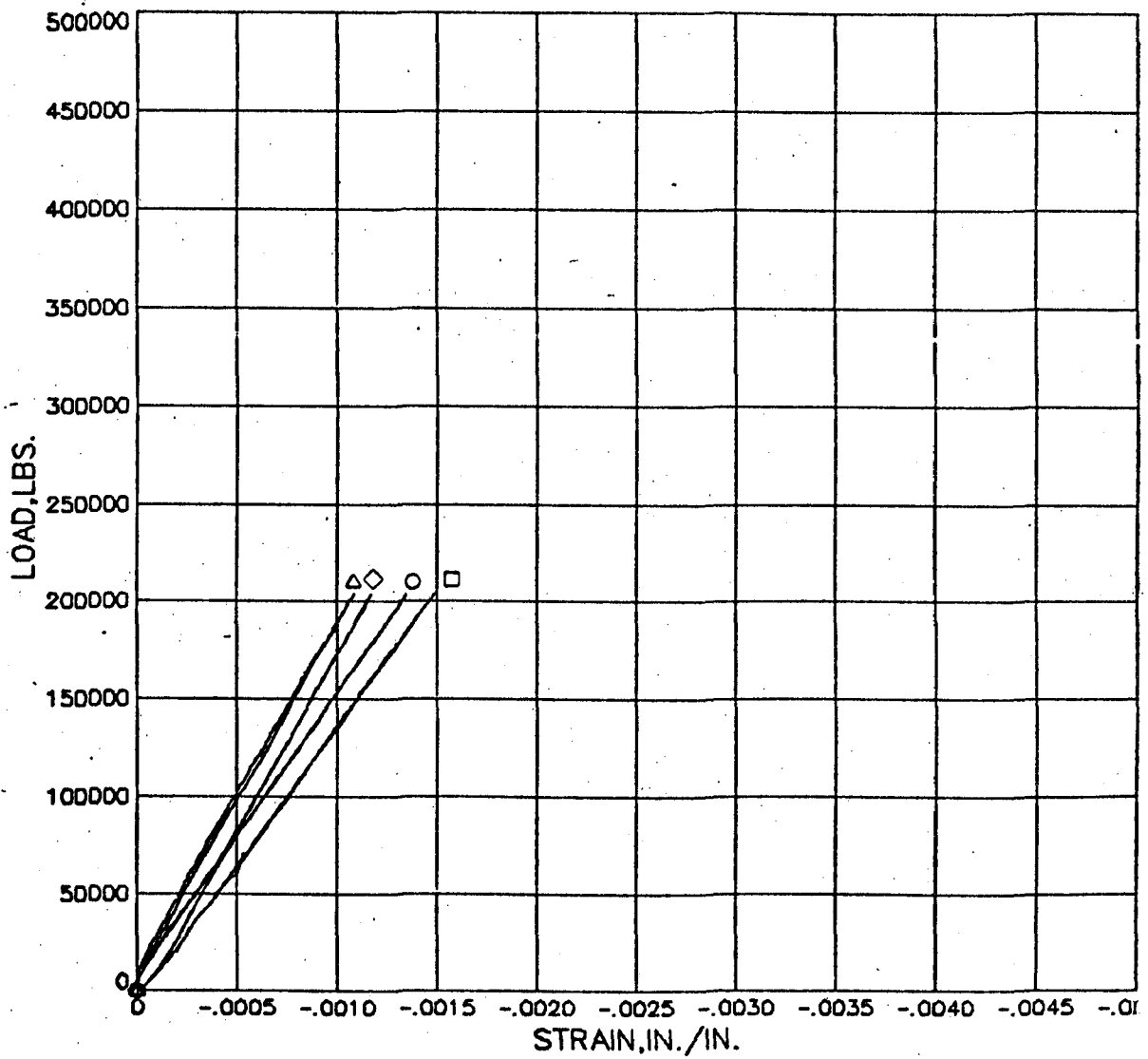

CONNECTION 314 COMPRESSION TEST

FIGURE 20A

TEST 314

RUN 7

S0-5 ○

S0-6 □

S0-7 ◇

S0-8 △

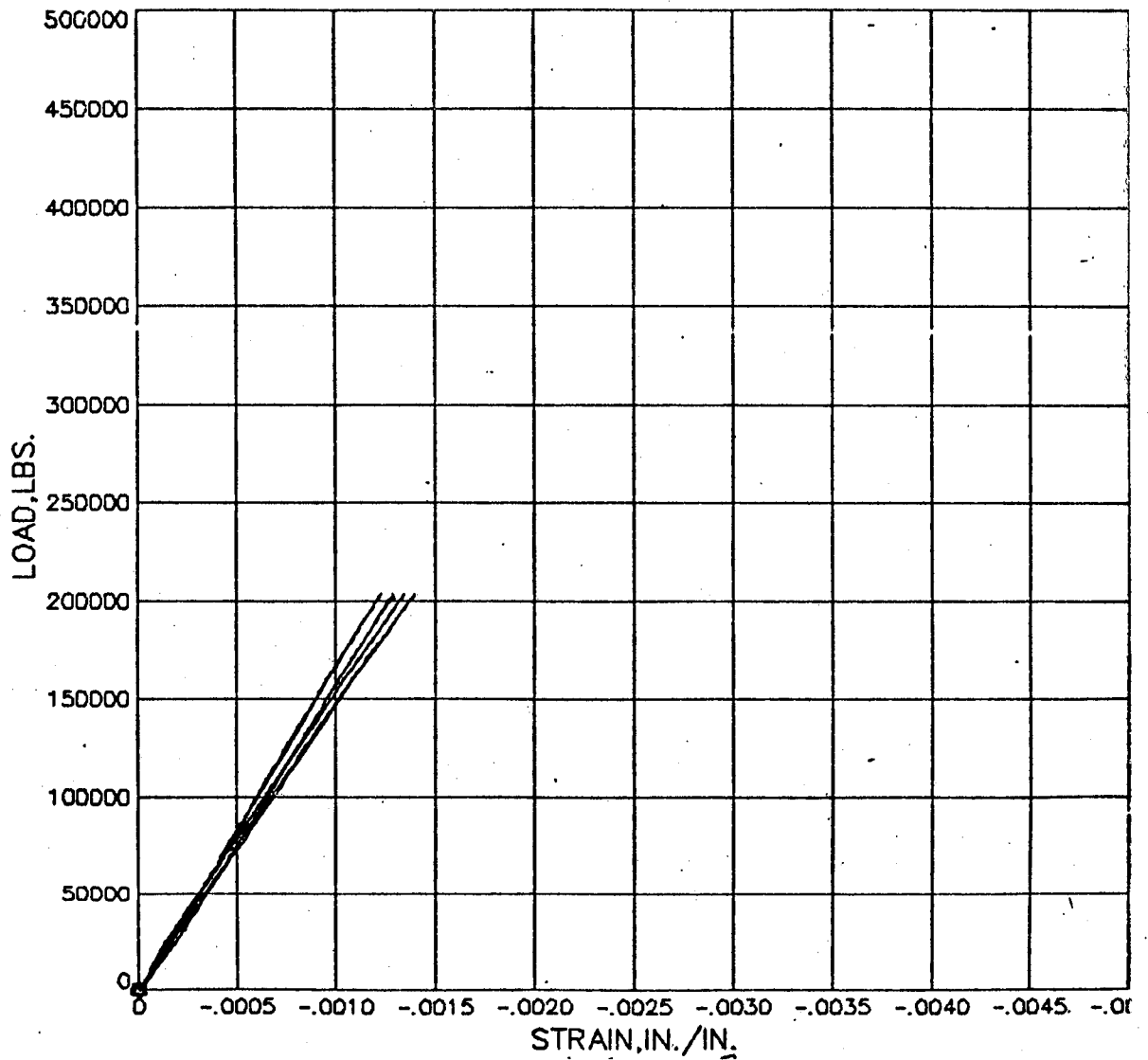

CONNECTION 314 COMPRESSION TEST

FIGURE 20B

TEST 314

RUN 7

S0-8 ○

S0-10 □

S0-11 ◇

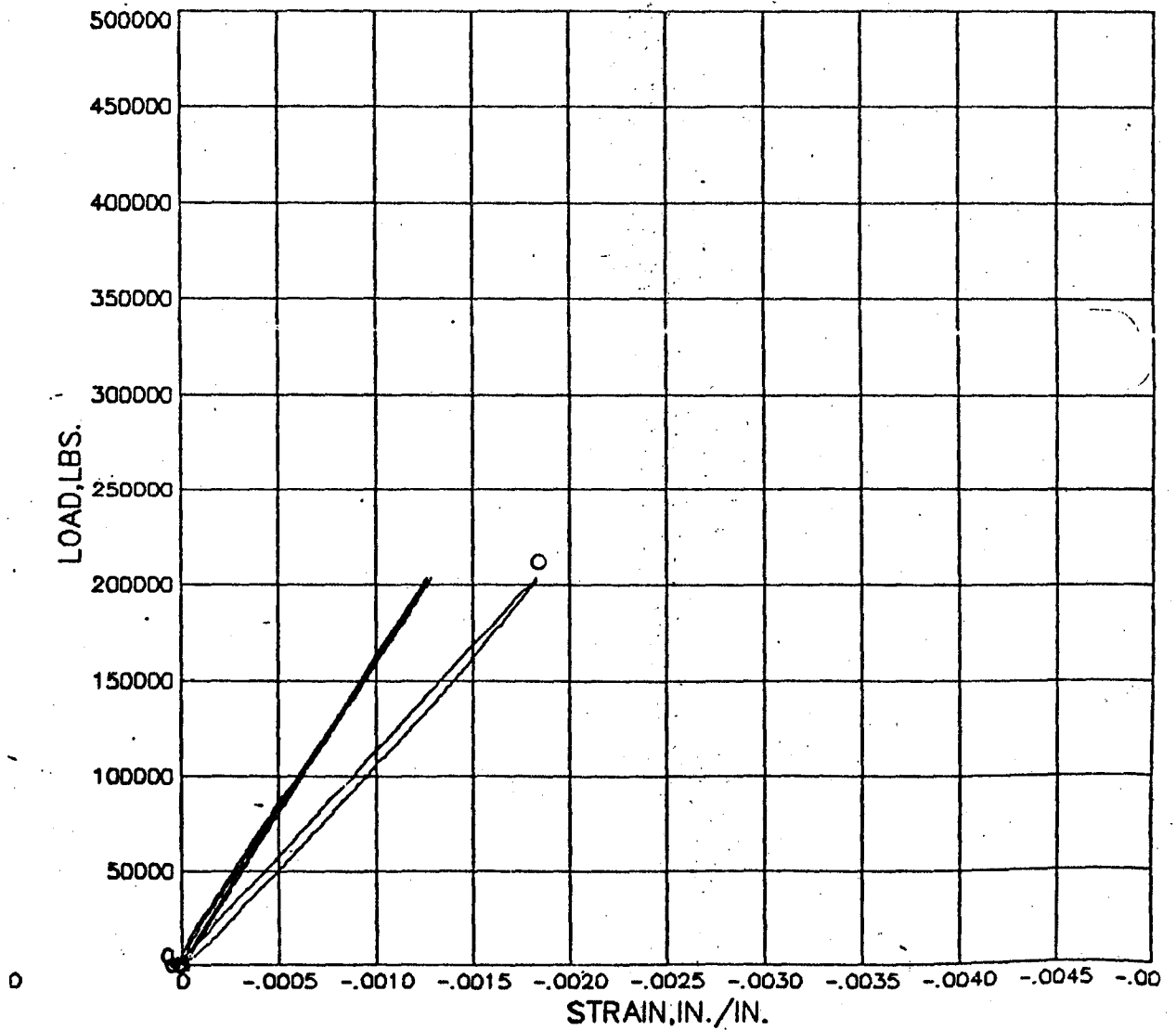

CONNECTION 314 COMPRESSION TEST

FIGURE 20C

TEST 314

RUN 7

S0-12 ○

S0-13 □

S0-14 ◇

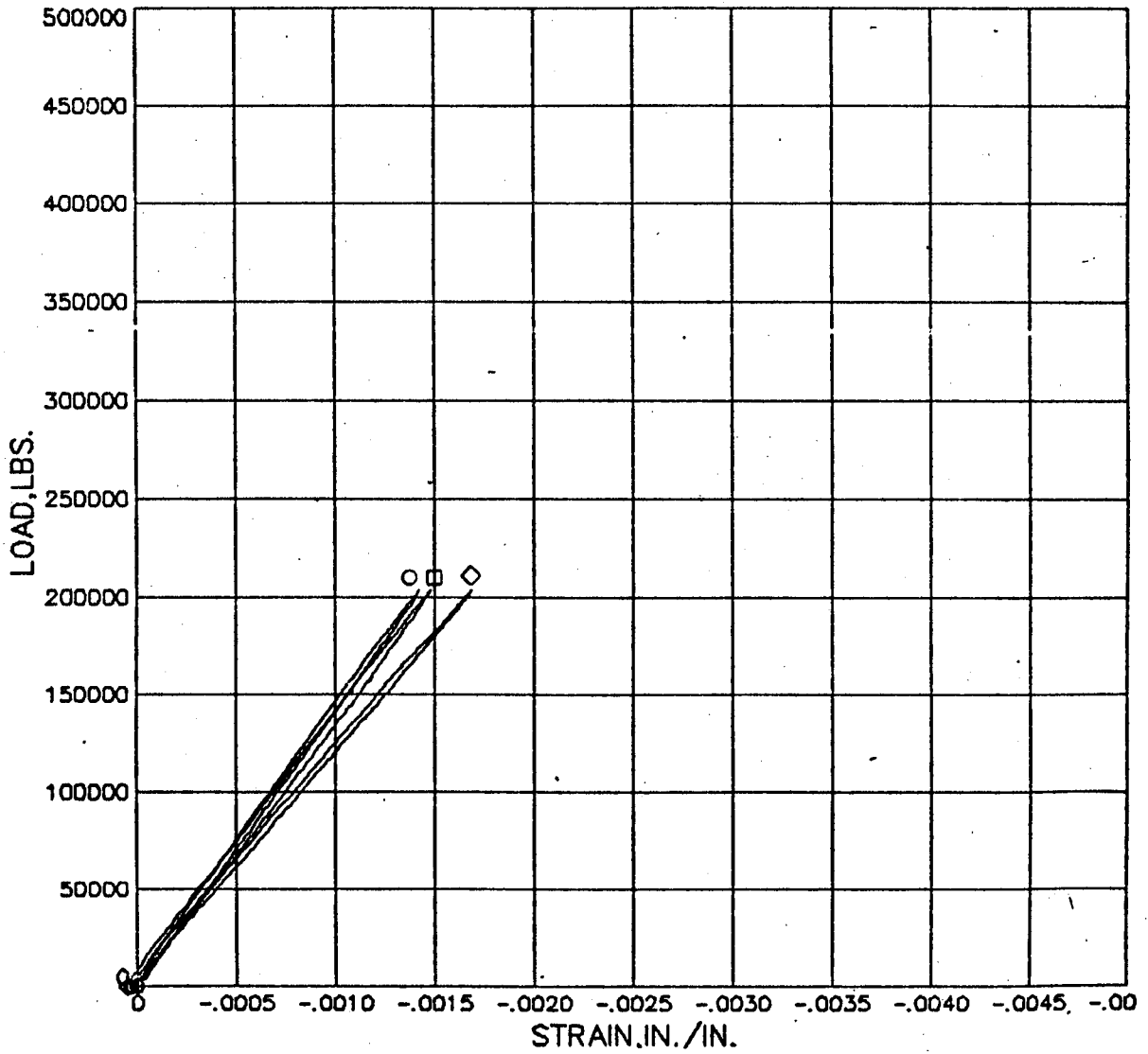

CONNECTION 314 COMPRESSION TEST

FIGURE 20D

TEST 314

RUN	7
S0-15	○
S0-16	□
S0-17	◇
S0-18	△

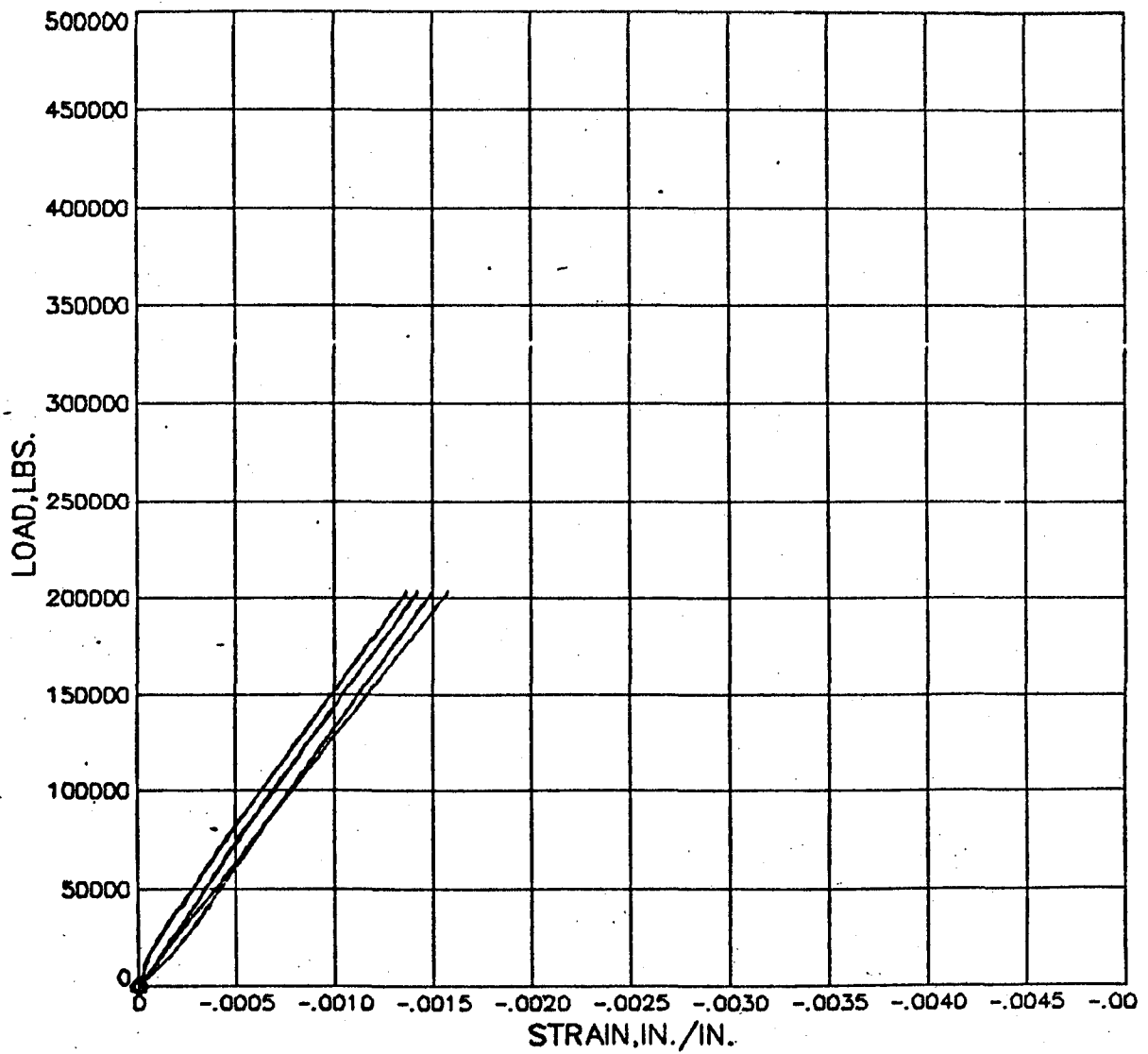

CONNECTION 314 COMPRESSION TEST

FIGURE 20E

TEST 314

- RUN 7
- S0-18 ○
- S0-20 □
- S0-21 ◇
- S0-22 ▲

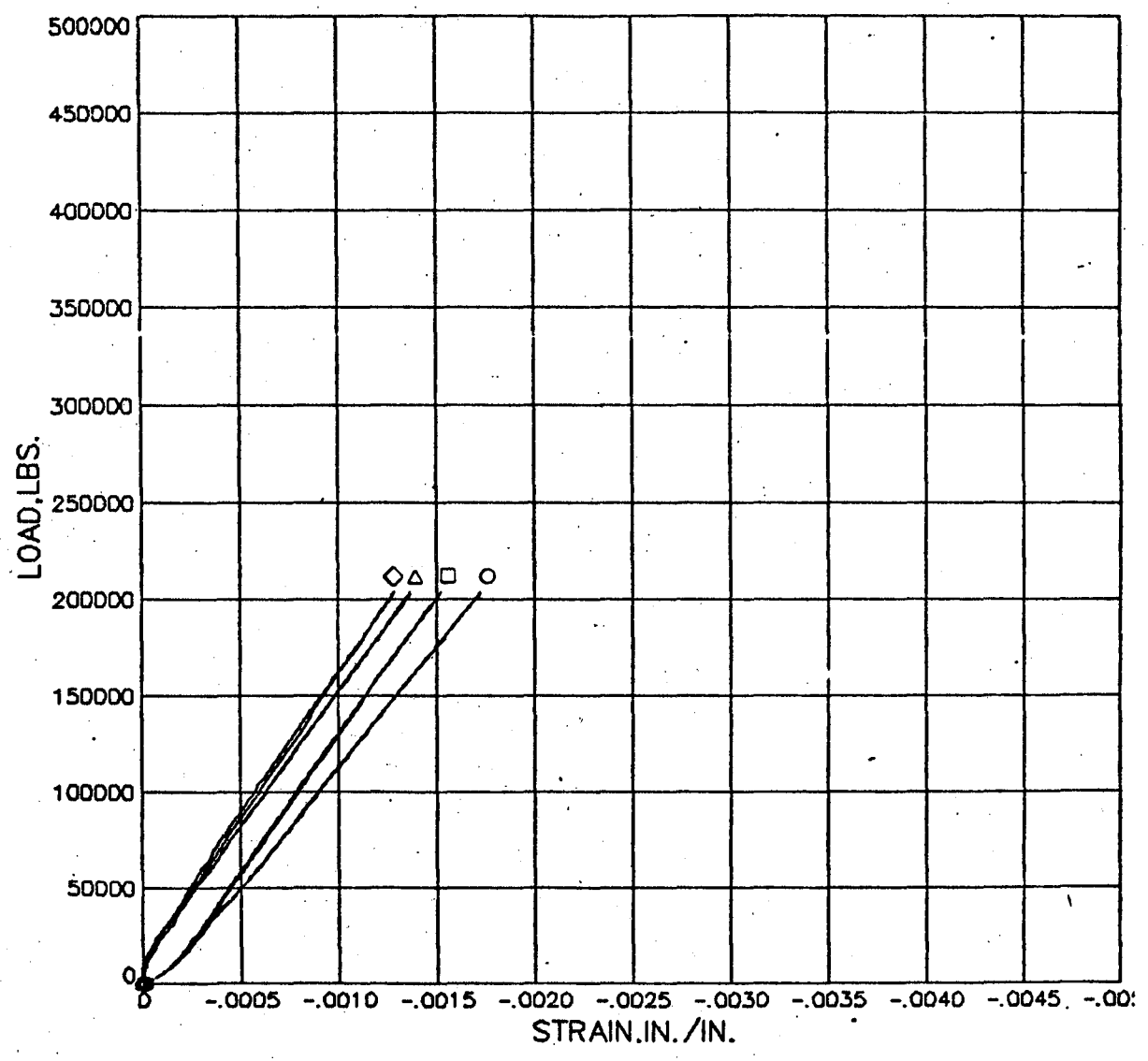

CONNECTION 314 COMPRESSION TEST

FIGURE 20F

TEST 314

RUN	6
S0-1	○
S0-2	□
S0-3	◇
S0-4	△

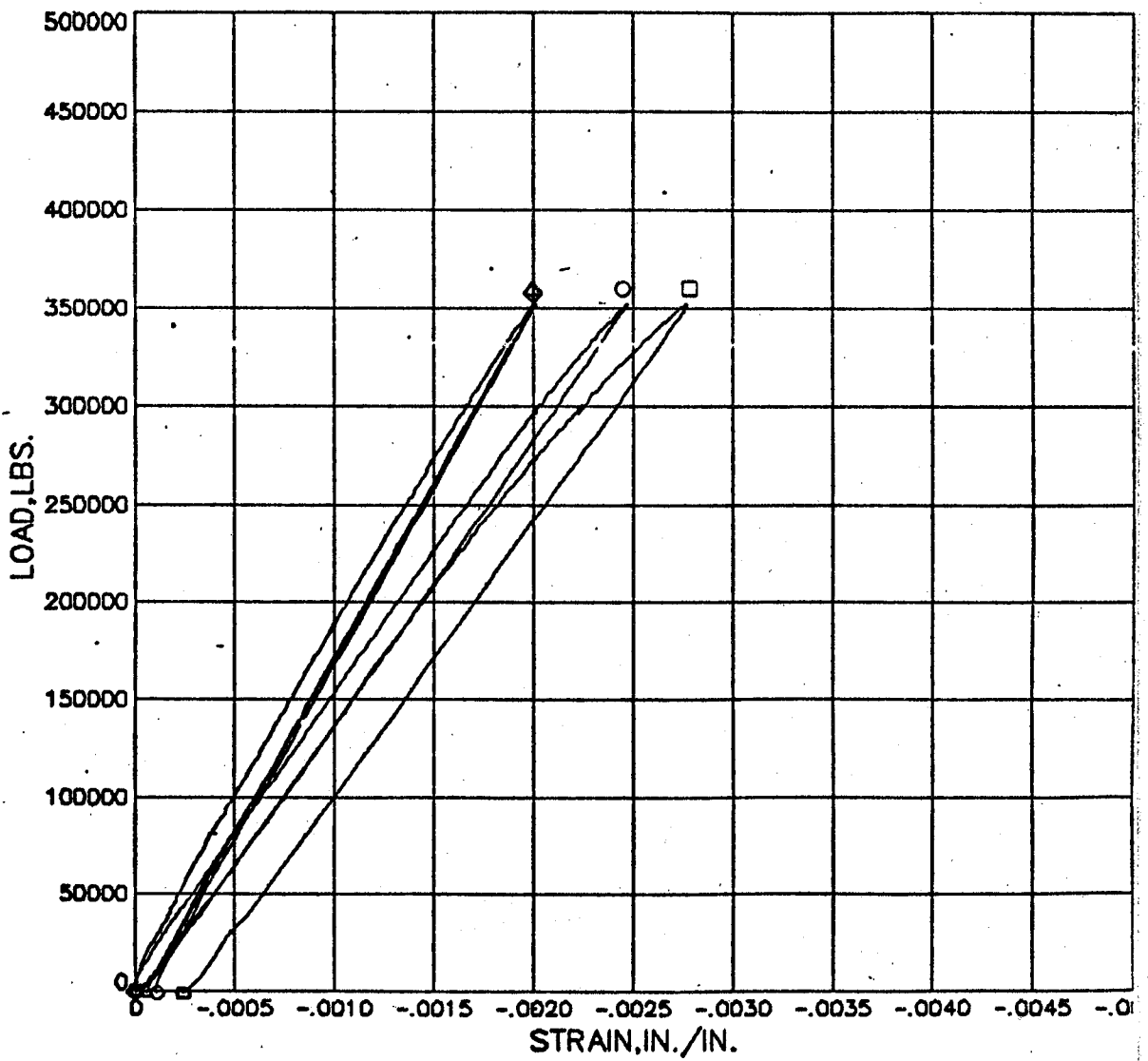

CONNECTION 314 COMPRESSION TEST

FIGURE 21A

TEST 314

RUN 6
S0-5 ○
S0-6 □
S0-7 ◇
S0-8 ▲

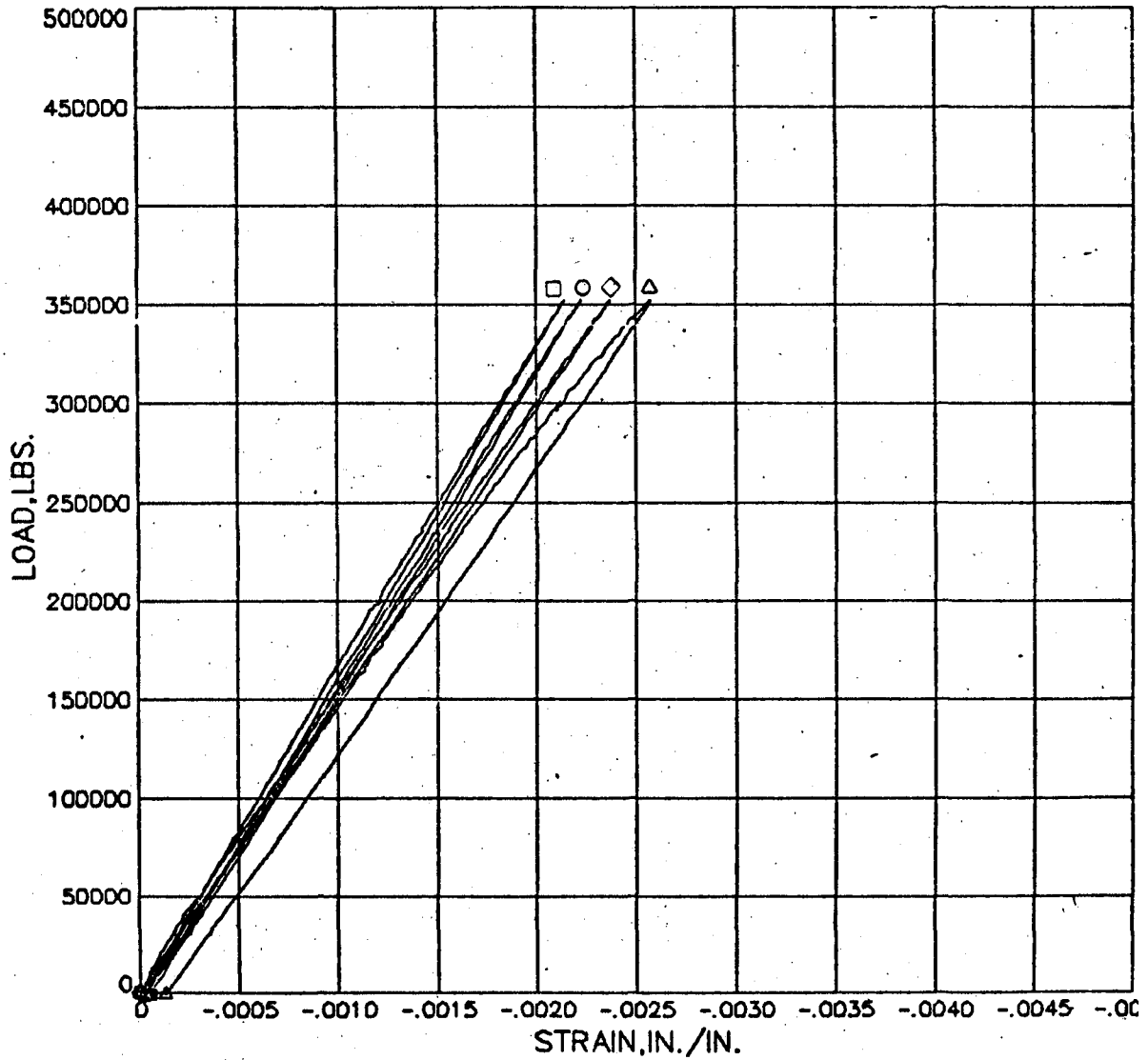

CONNECTION 314 COMPRESSION TEST
FIGURE 21B

TEST 314

RUN	8
S0-9	○
S0-10	□
S0-11	◇

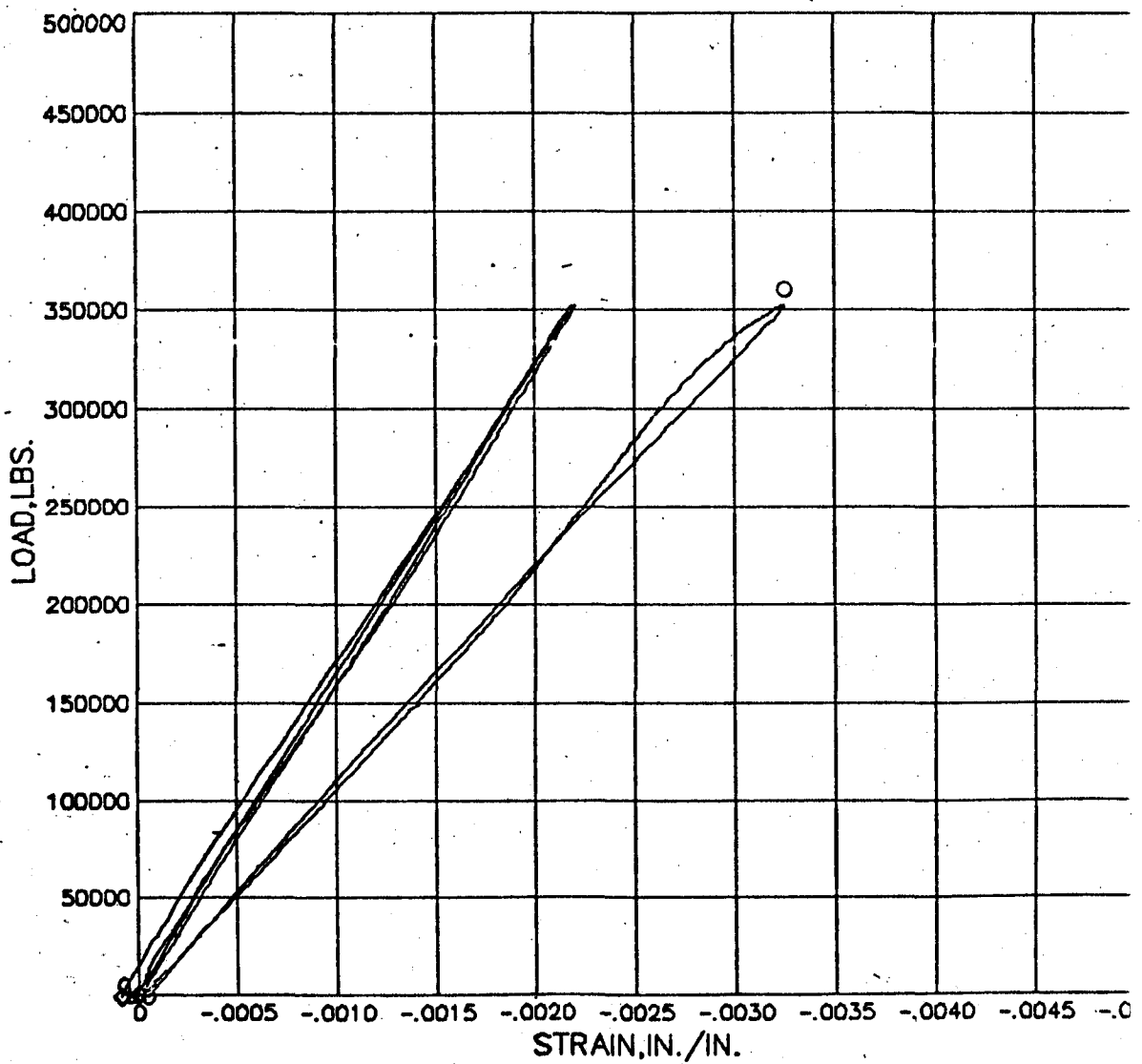

CONNECTION 314 COMPRESSION TEST

FIGURE 21C

TEST 314

RUN	8
SG-12	○
SG-13	□
SG-14	◇

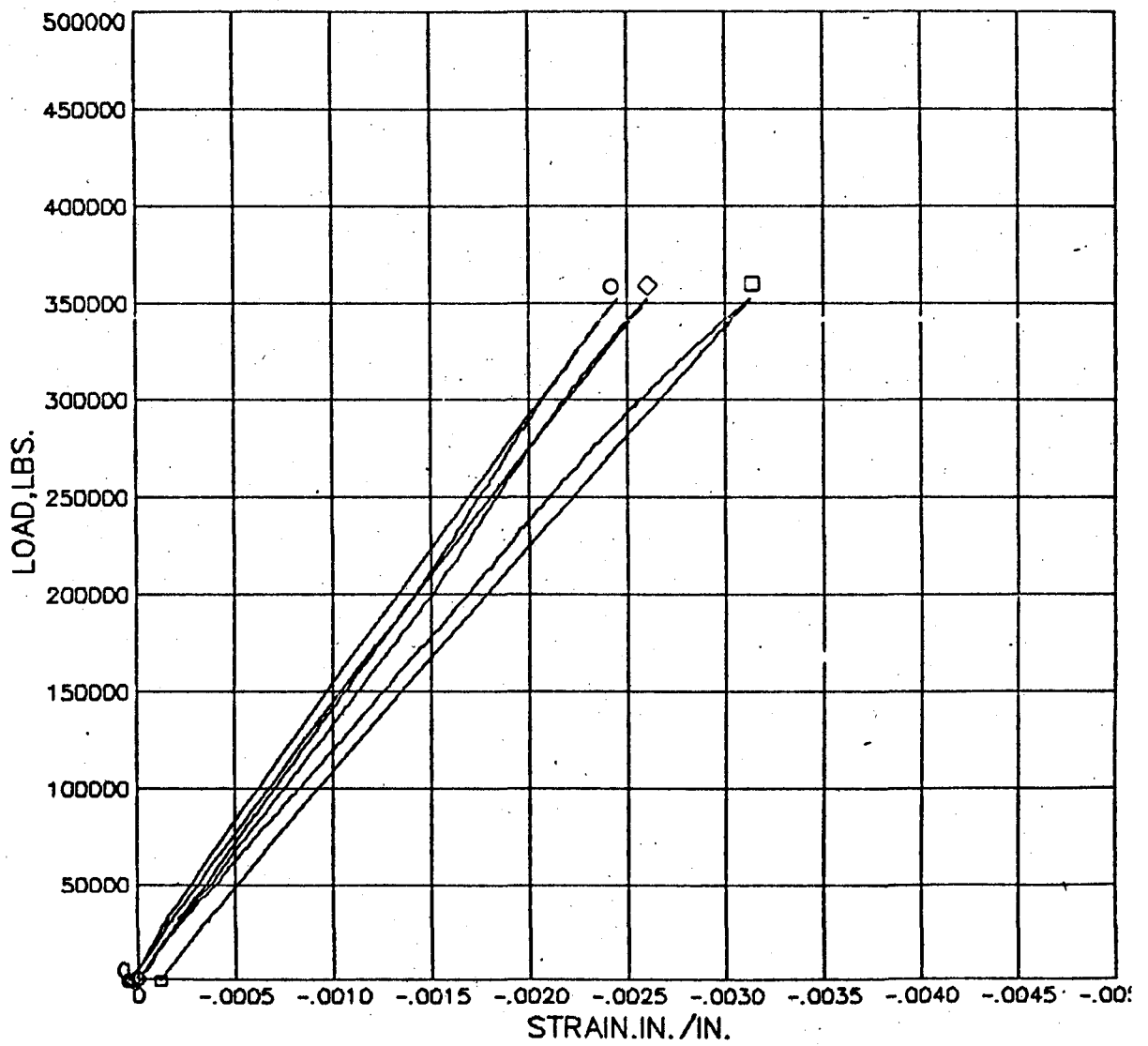

CONNECTION 314 COMPRESSION TEST

FIGURE 21D

TEST 314

RUN	●
S0-15	○
S0-16	□
S0-17	◇
S0-18	△

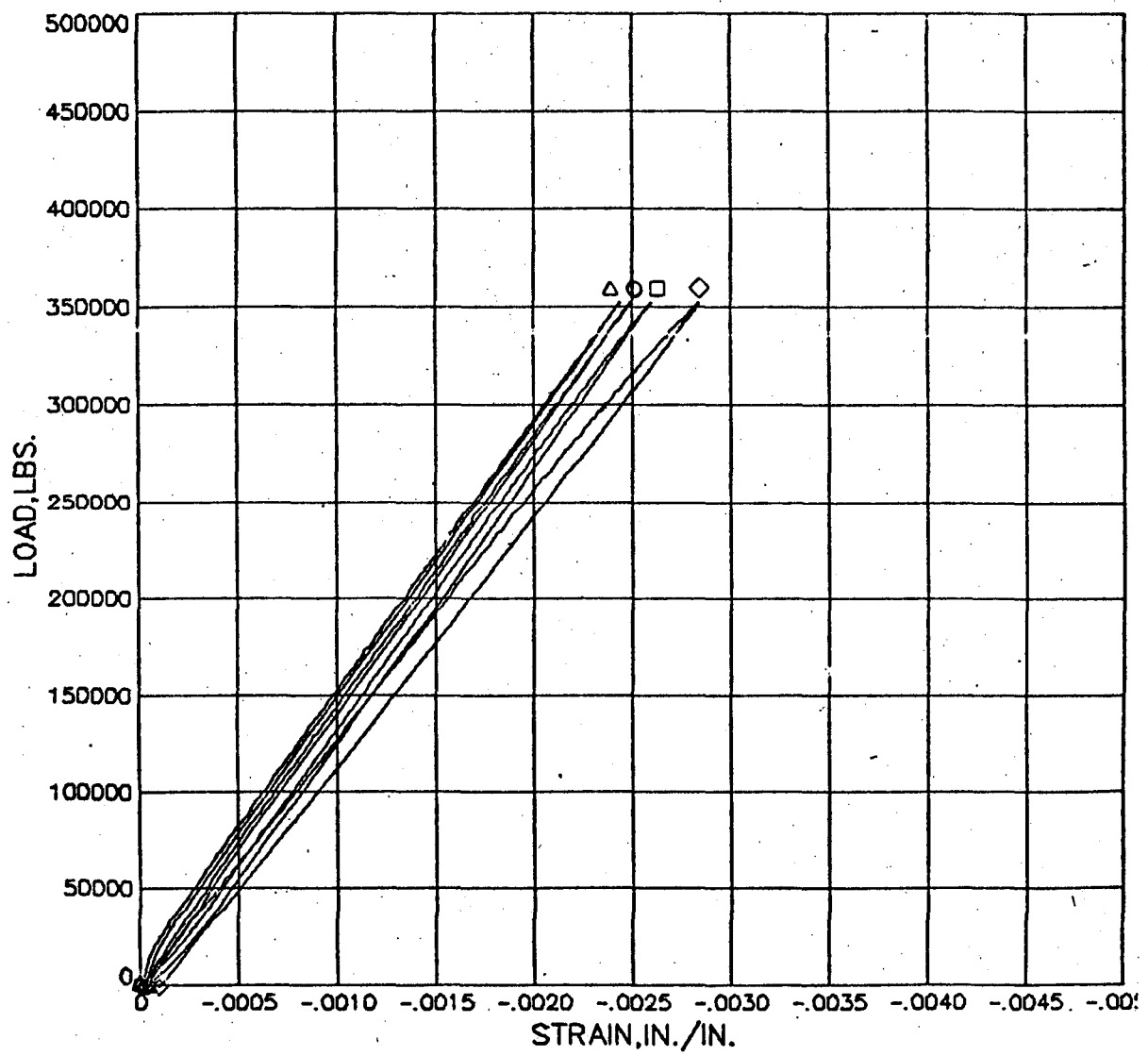

CONNECTION 314 COMPRESSION TEST

FIGURE 21E

TEST 314

RUN	Symbol
S0-19	○
S0-20	□
S0-21	◇
S0-22	△

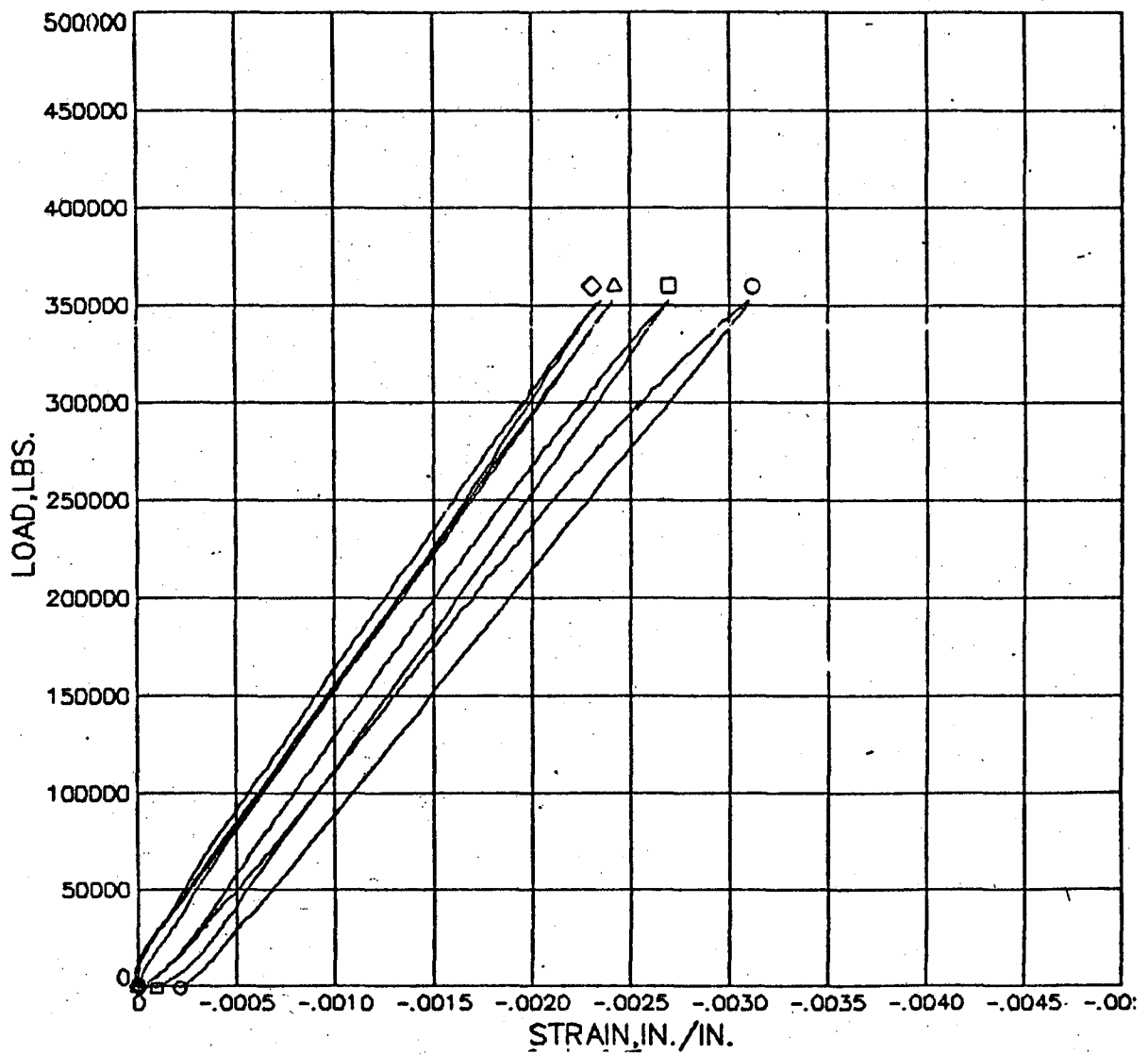

CONNECTION 314 COMPRESSION TEST

FIGURE 21F

TEST 314

- RUN ●
- 88-1 ○
- 88-2 □
- 88-3 ◇
- 88-4 △

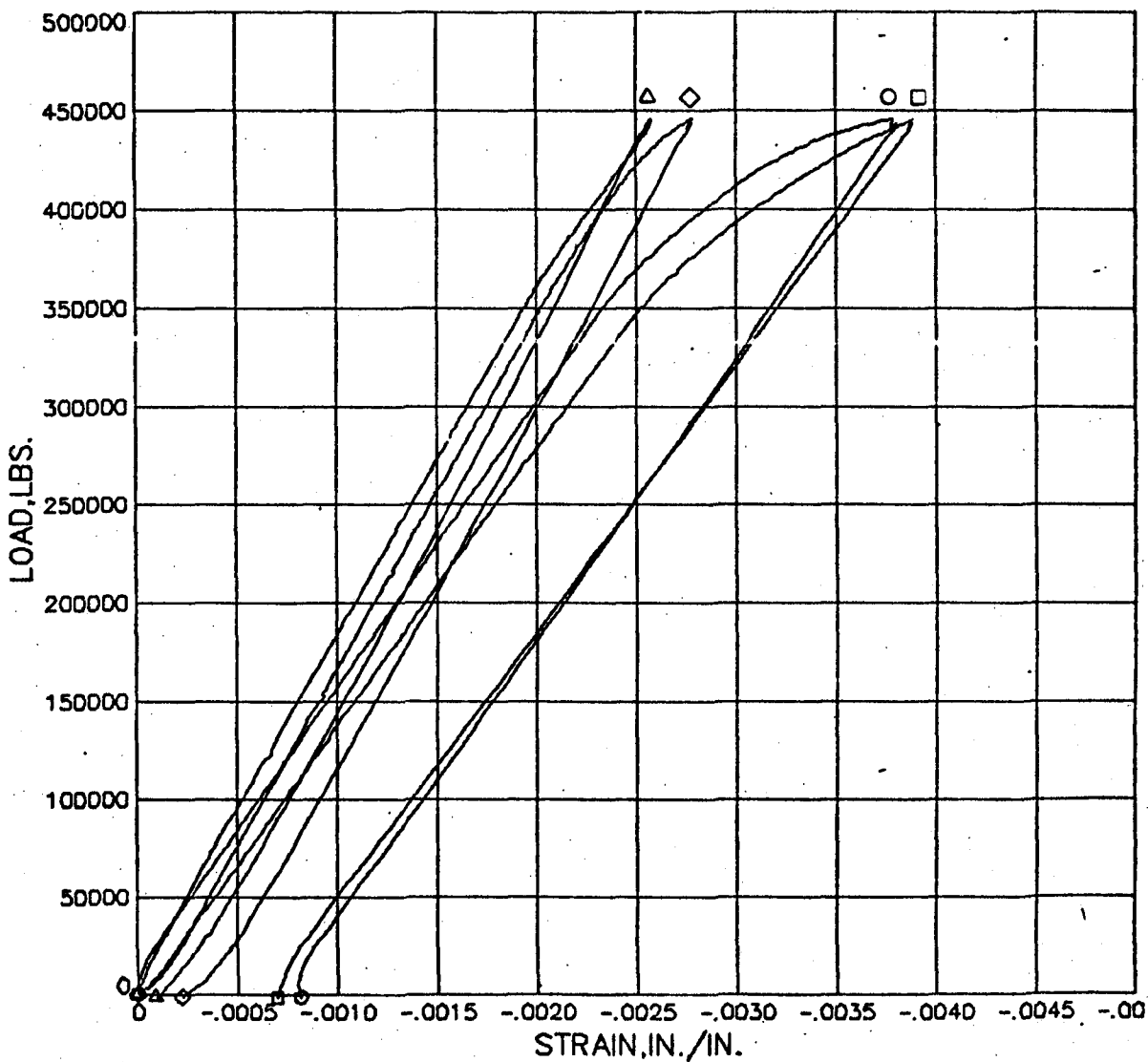

CONNECTION 314 COMPRESSION TEST

FIGURE 22A

TEST 314

RUN	●
S0-5	○
S0-6	□
S0-7	◇
S0-8	△

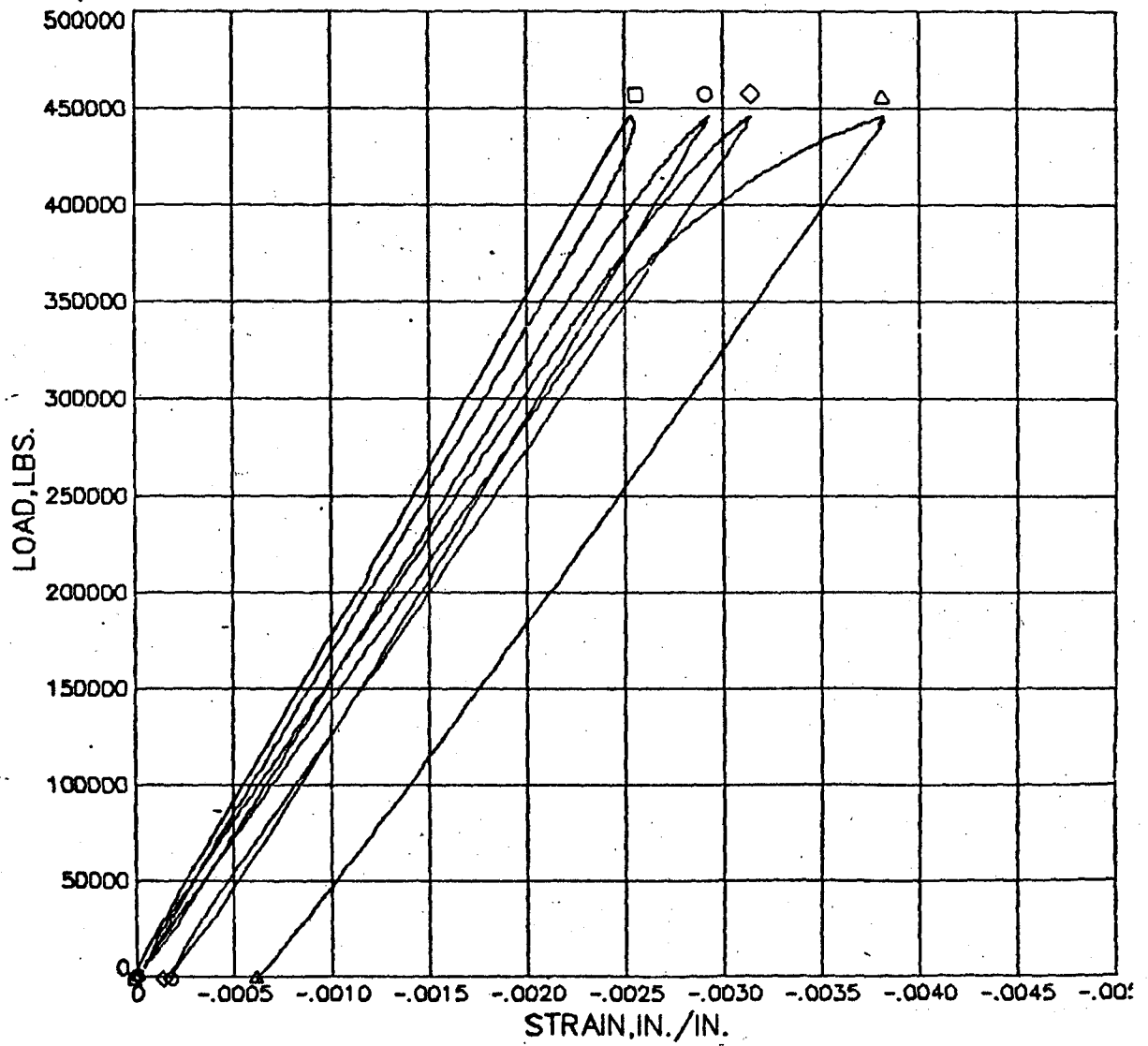

CONNECTION 314 COMPRESSION TEST

FIGURE 22B

TEST 314

RUN	●
S0-9	○
S0-10	□
S0-11	◇

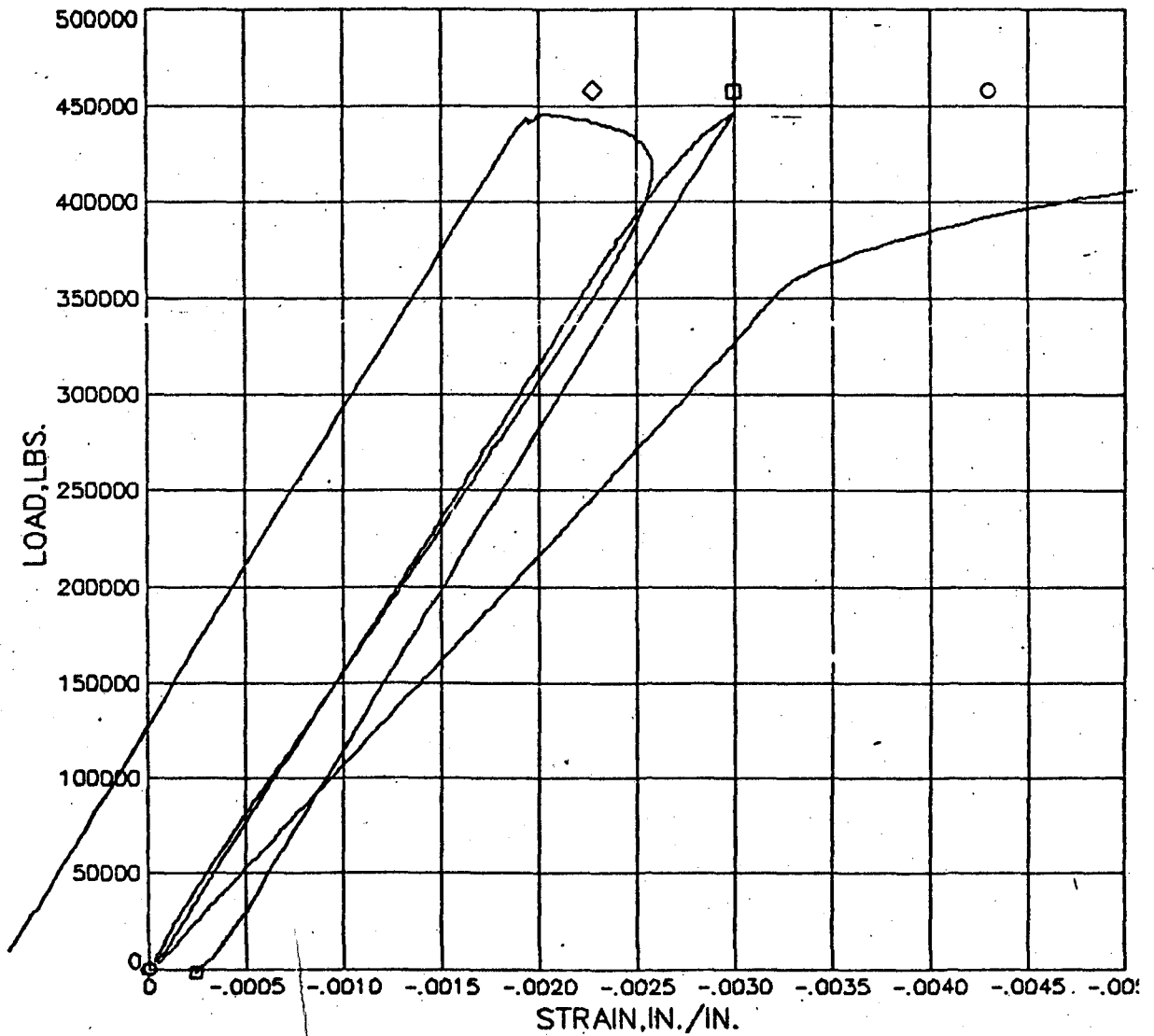

CONNECTION 314 COMPRESSION TEST

FIGURE 22C

TEST 314

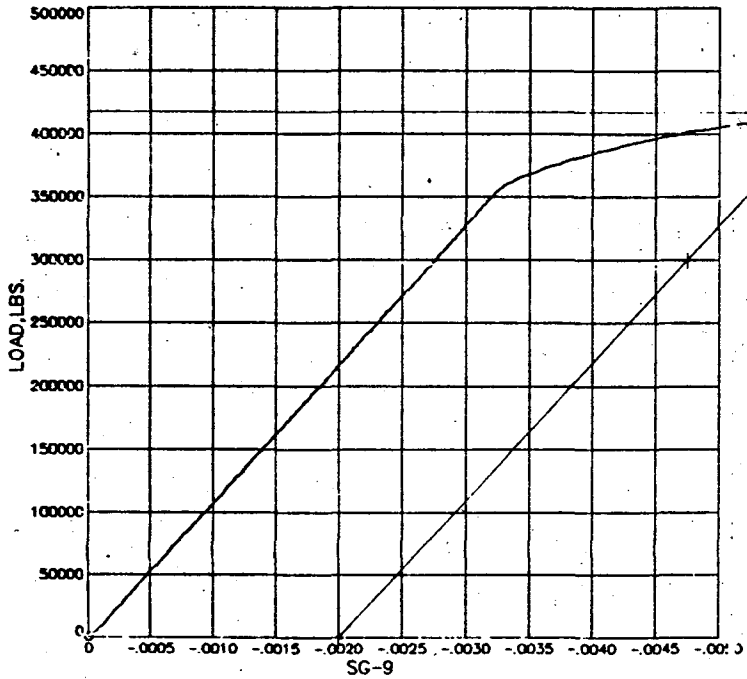

418000 LBS YIELD
AT .2% OFFSET

CONNECTION 314 COMPRESSION TEST
FIGURE 22C (CONT'D)

TEST 314

RUN 8
S0-12 ○
S0-13 □
S0-14 ◇

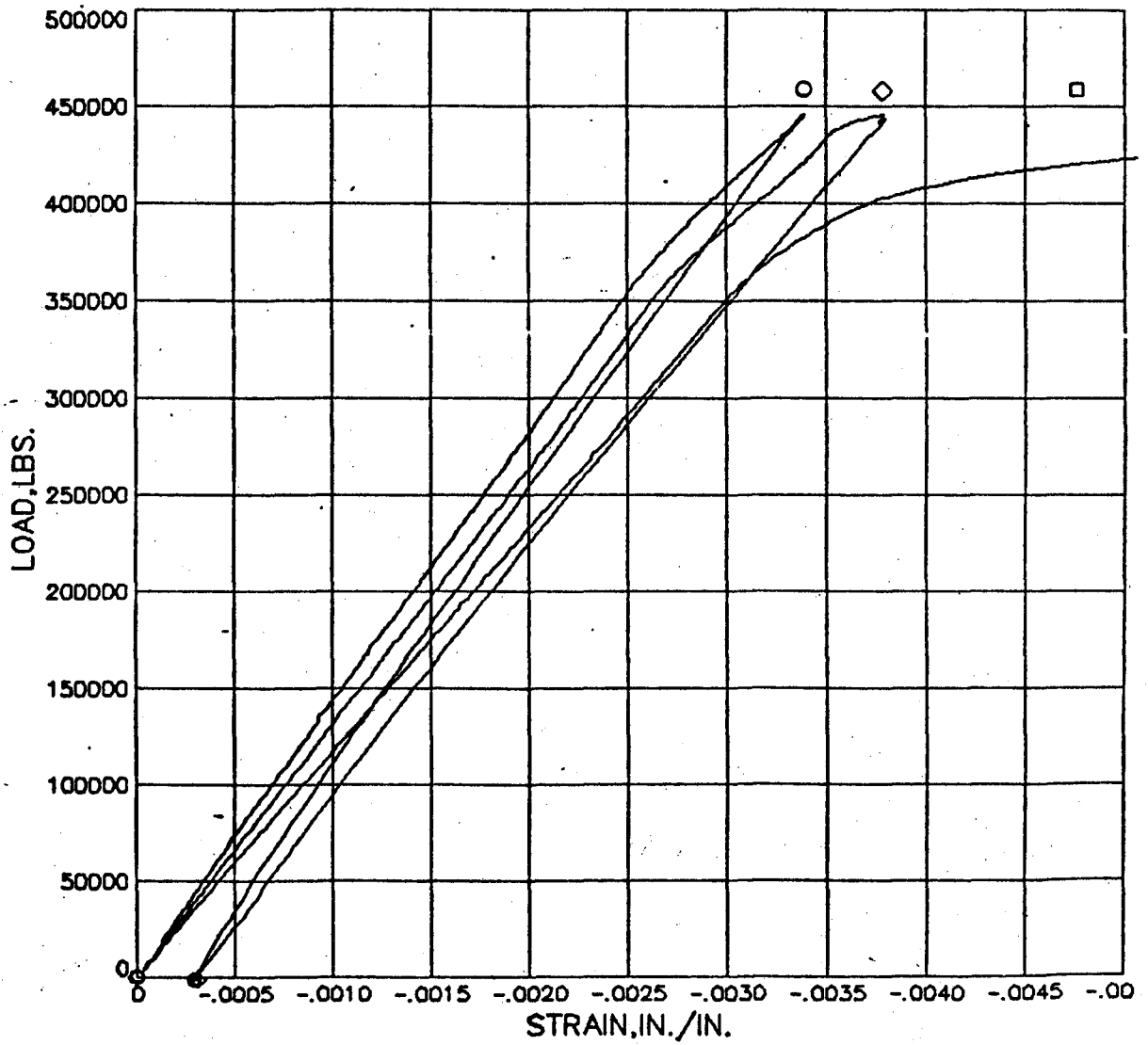

CONNECTION 314 COMPRESSION TEST
FIGURE 22D

TEST 314

CONNECTION 314 COMPRESSION TEST
FIGURE 22D (CONT'D)

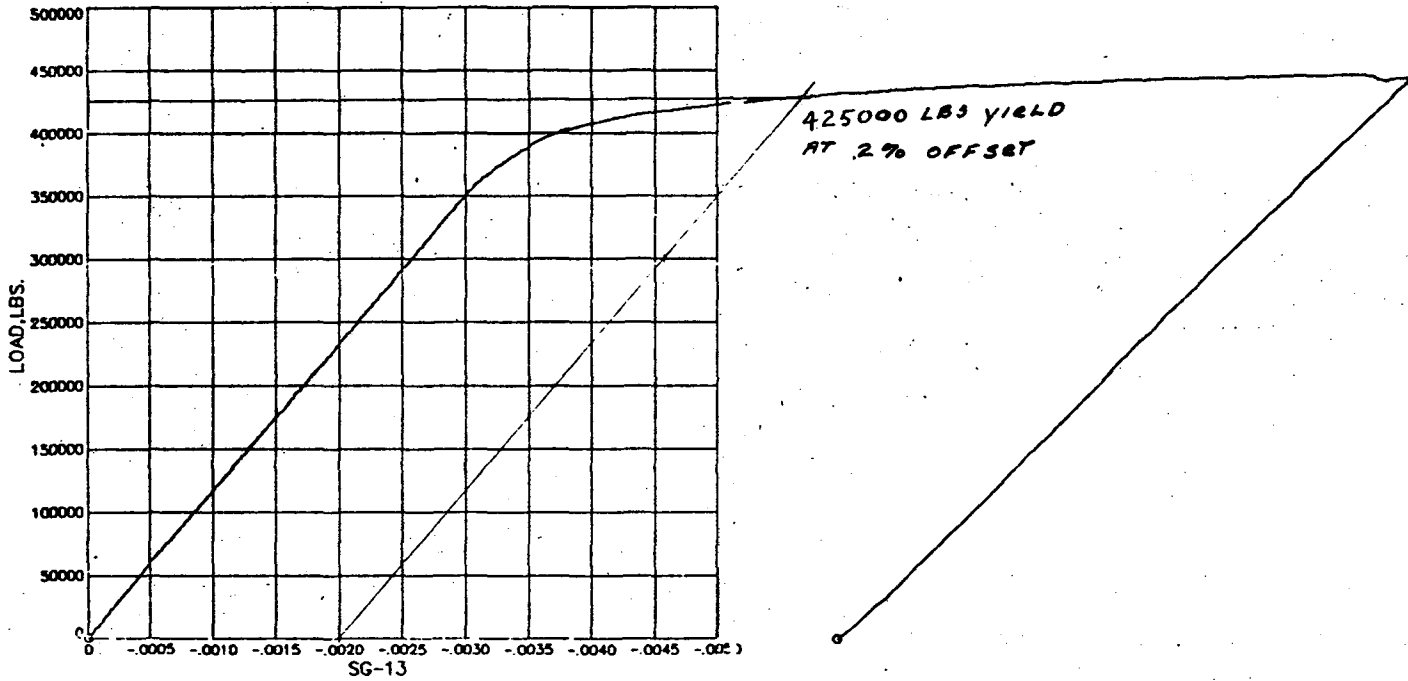

TEST 314

RUN	●
S0-15	○
S0-16	□
S0-17	◇
S0-18	△

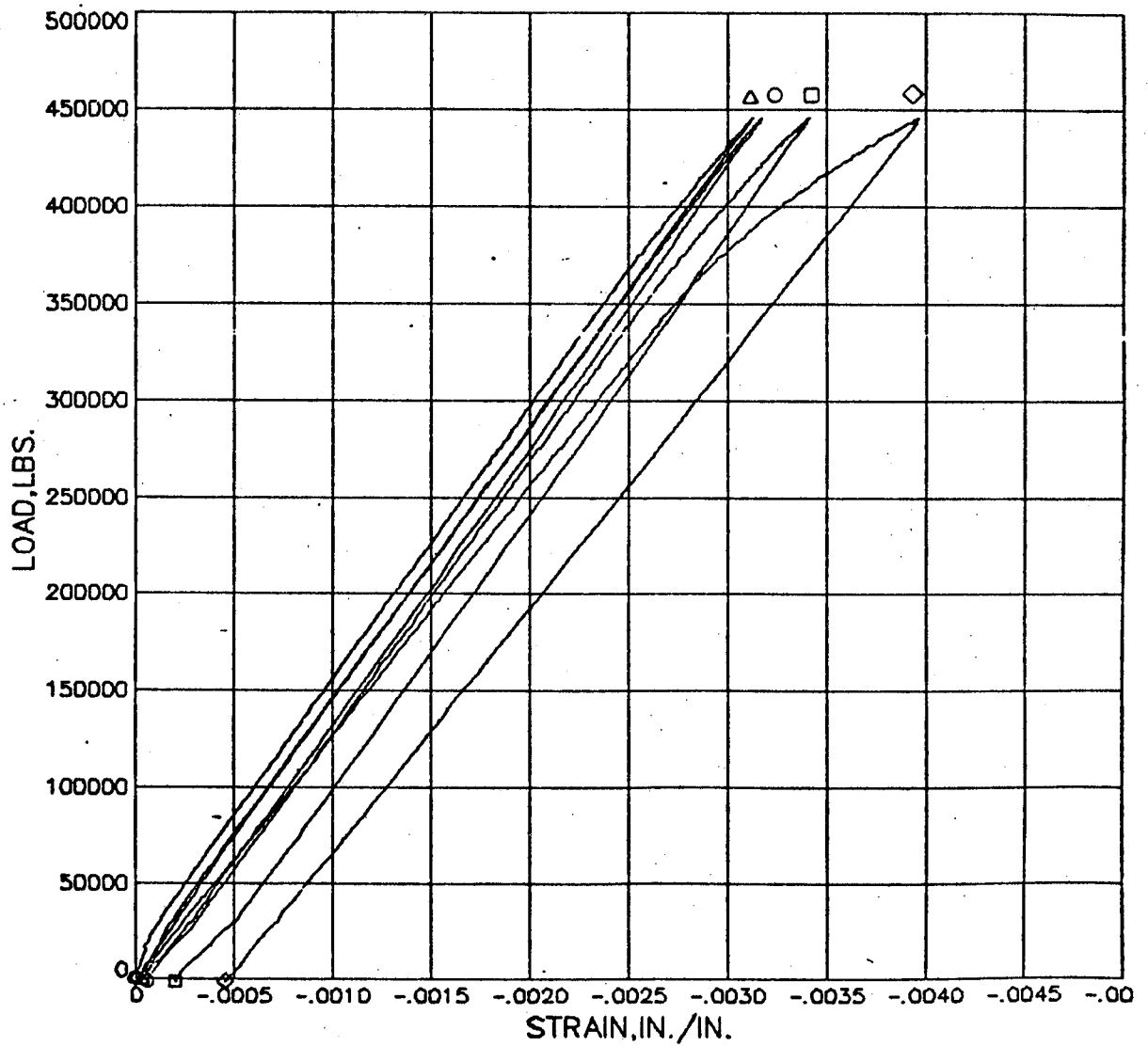

CONNECTION 314 COMPRESSION TEST

FIGURE 22E

TEST 314

RUN	●
SQ-18	○
SQ-20	□
SQ-21	◇
SQ-22	△

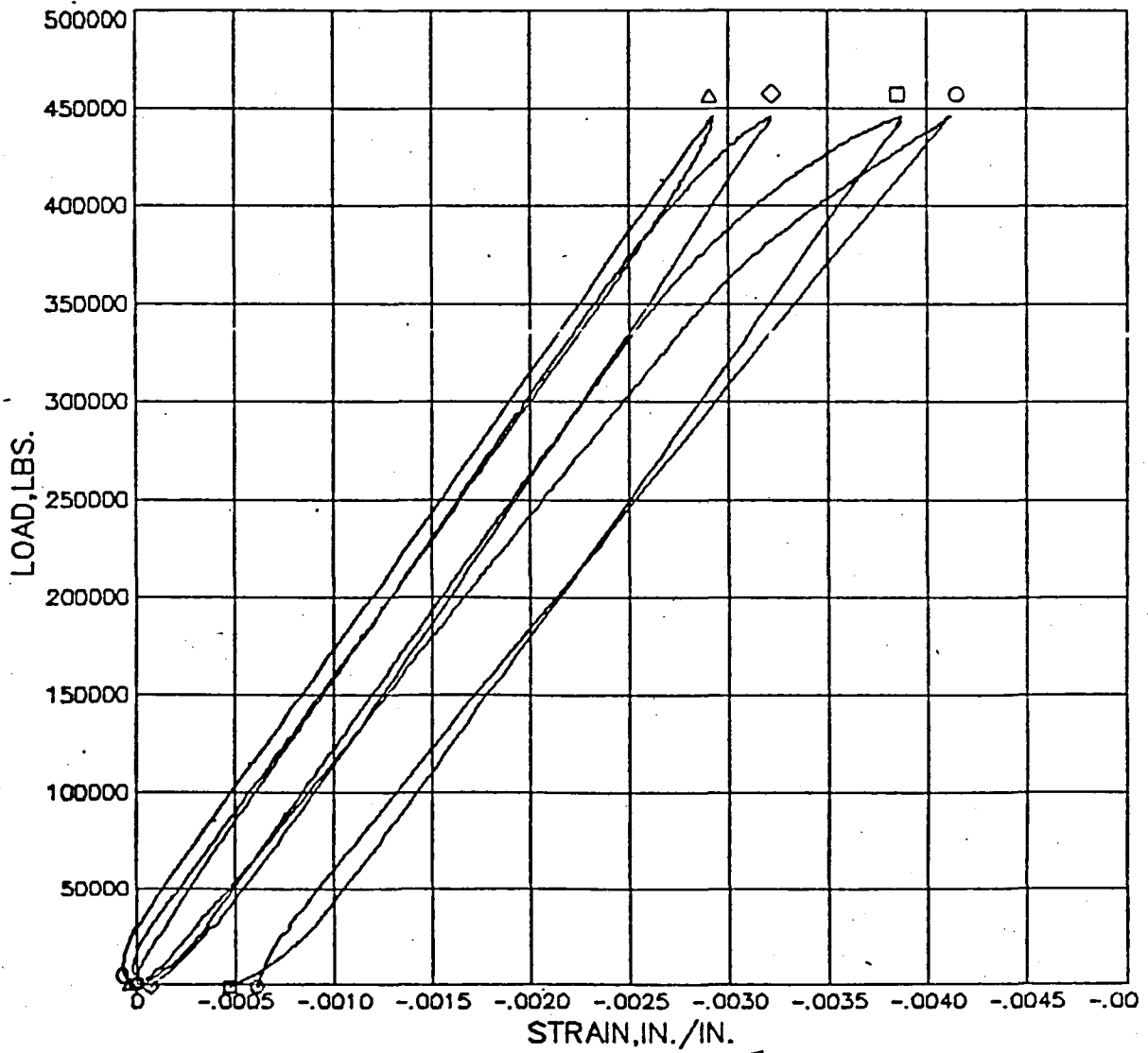

CONNECTION 314 COMPRESSION TEST

FIGURE 22F

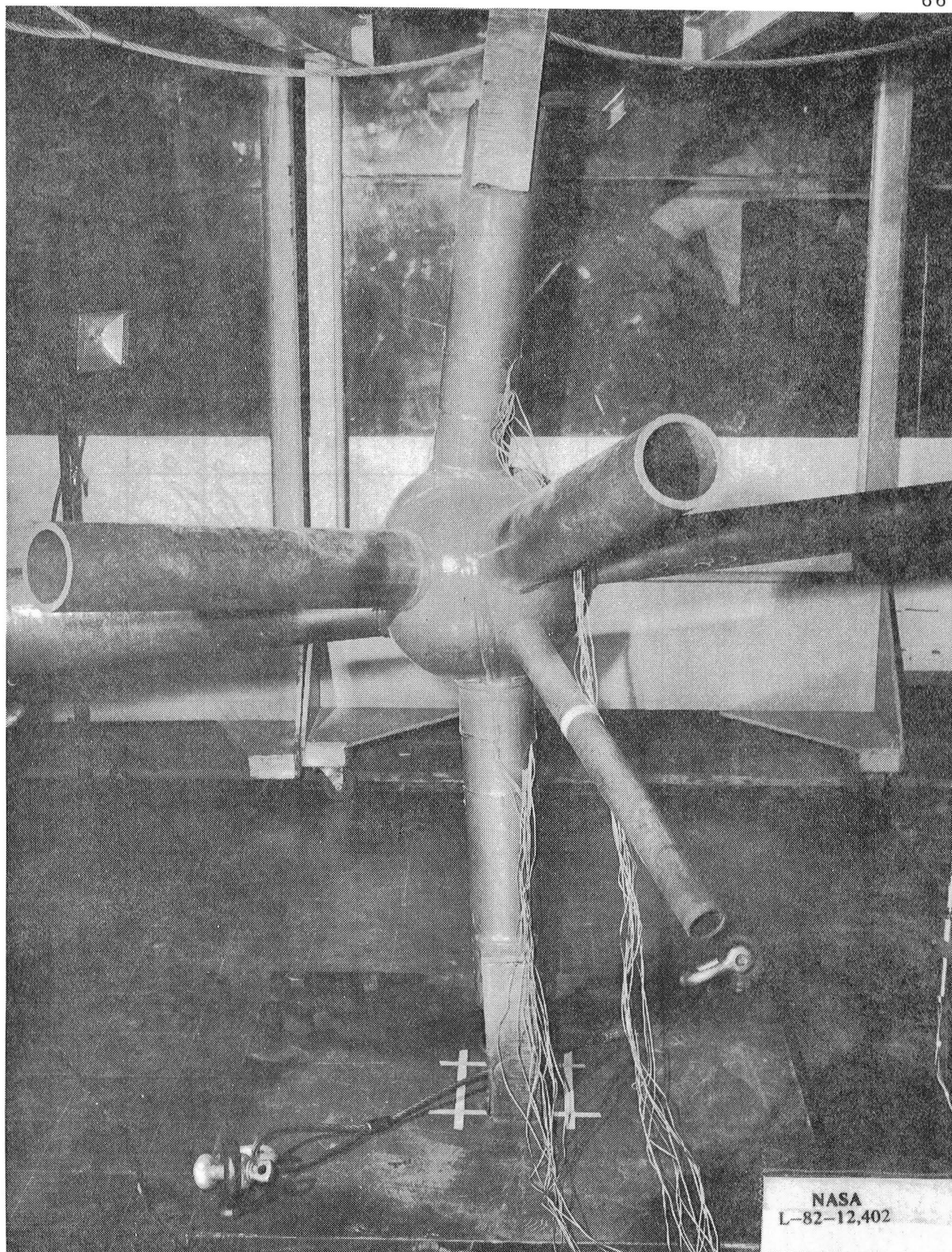

CONNECTION 314 AFTER COMPRESSION TEST

FIGURE 23

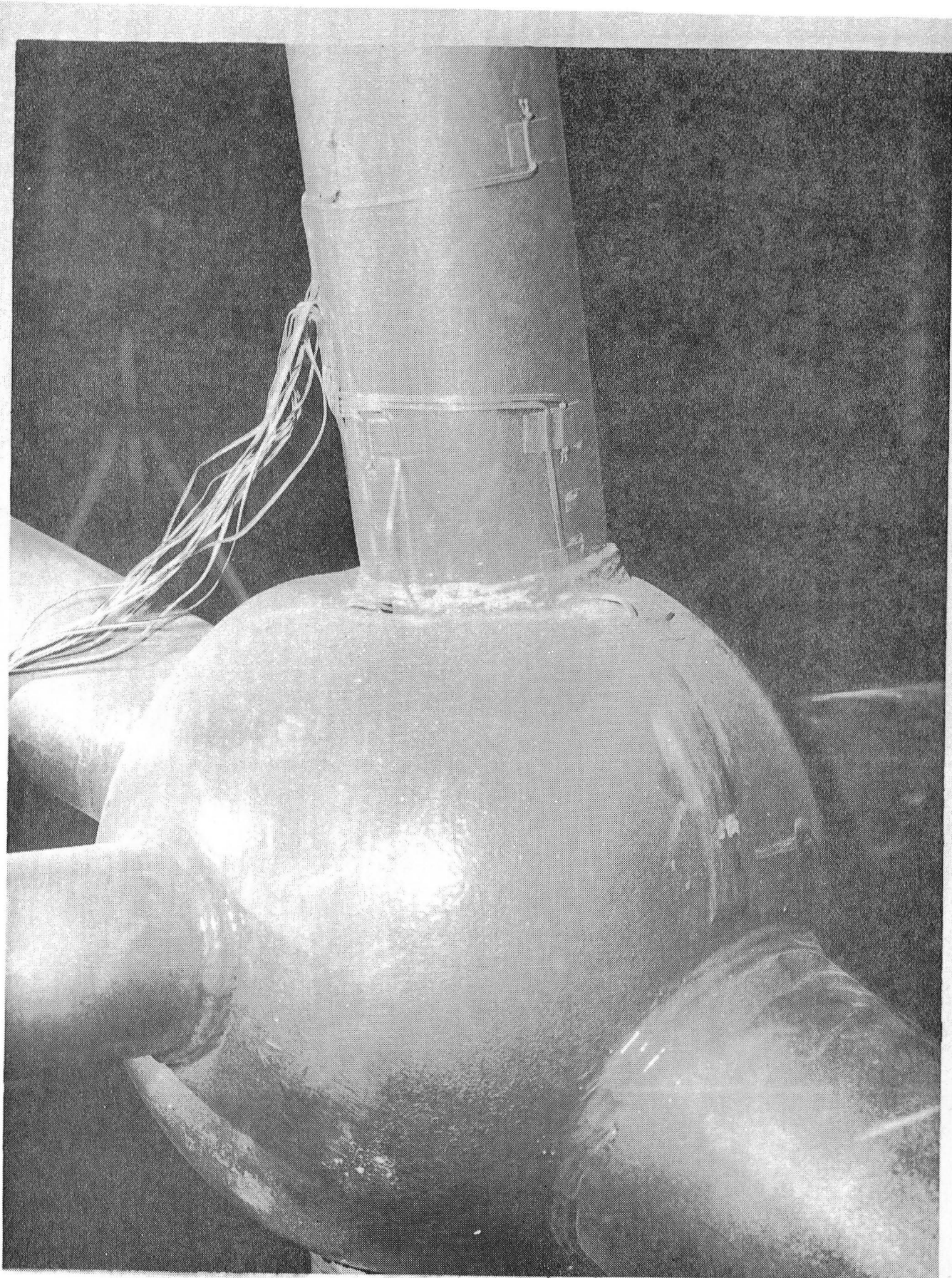

NASA
L-82-12,409

CONNECTION 314 AFTER COMPRESSION TEST

FIGURE 24

1. Report No. NASA TM-85802		2. Government Accession No.		3. Recipient's Catalog No.	
4. Title and Subtitle Aircraft Landing Dynamics Facility Carriage Weld Test Program				5. Report Date September 1984	
				6. Performing Organization Code 505-45-23-01	
7. Author(s) Ashby G. Lawson				8. Performing Organization Report No.	
9. Performing Organization Name and Address NASA-Langley Research Center Hampton, VA 23665				10. Work Unit No.	
				11. Contract or Grant No.	
12. Sponsoring Agency Name and Address National Aeronautics and Space Administration Washington, DC 20546				13. Type of Report and Period Covered Technical Memorandum	
				14. Sponsoring Agency Code	
15. Supplementary Notes Use of commercial products or names of manufacturers in this report does not constitute official endorsement of such products or manufacturers, either expressed or implied, by NASA.					
16. Abstract The test program was in support of a welded tubular structure constructed of low alloy high strength quenched and tempered steel. The report characterizes the consistency of the mechanical strengths and chemical composition and the degree of difficulty of obtaining full strength welds with these steels. Also, reported are the results of constructing and testing two typical connections which are used in the structure design.					
17. Key Words (Suggested by Author(s)) Welding Low Alloy Quenched and Tempered Steel AWS D1.1 Weld Requirements				18. Distribution Statement Unclassified - Unlimited Subject Cat. 37	
19. Security Classif. (of this report) Unclassified		20. Security Classif. (of this page) Unclassified		21. No. of Pages 69	22. Price A04

